

# VOLVO PENTA INBOARD DIESEL

# D12-675

496 kW (675 hp) crankshaft power acc. to ISO 8665

## Excellent Performance and Pleasant Cruising

The D12-675 is a further development of the successful and well-proven high pressure unit-injected and 4 valves per cylinder D12 marine engine. Electronically governed wastegate turbo, a new-designed heat exchanger for reduced charge-air-cooling temperature in combination with a new injection system, and a new Engine Management System (EMS-2) further improve performance and driveability, meeting future stringent emission requirements.

A rigid in-line six cylinder block with ladder frame and vibration dampers on the camshaft results in a smooth-running engine for high onboard comfort.



### World-class performance

The high pressure unit injector system, controlled by electronic management, modern engine technology in combination with an electronically governed wastegate turbo ensure high power, low fuel consumption, and outstanding torque during acceleration, with virtually no sign of smoke. This matched with the engine's high load carrying capability creates a sporty feeling and power, when needed.

### Comfort and high quality

The D12-675 is a further development of the well-proven Volvo Penta D12 in-line six concept with robust block design, ladder frame and a one-piece cylinder head with overhead camshaft and 4-valve technology. This contributes to smooth running, high reliability and long-term durability.

The D12-675 is built in the world's most highly automated diesel engine factory line with a robotic machining line with computer controlled audit checks, which ensures the highest quality level.

### EVC/EC - Plug and go

EVC Electronic Vessel Control is the latest development in engine control and instrumentation for Volvo Penta marine engines. It offers a higher level of integration in your boat: electronic shift and throttle for smooth and safe control, a complete range of easy to read data link gauges, an EVC System Display (option) and much more, everything in just one CAN cable.

EVC makes boating easier and safer with twin engine synchronization and new software functions such as Volvo Penta Low Speed (option), which significantly reduces boat speed at idle to simplify maneuvering in tight quarters.

EVC is scalable from one station up to four, from a classic dashboard up to an advanced driver information system. EVC works closely together with the engine management system offering you constant power output regardless of fuel temperature (5–55°C/41–131°F) and quality. The system is built on the latest automotive technology with waterproof connectors, so it's just plug and go.

### Ease of service and maintenance

The EVC system features a self-diagnostic facility, which indicates at the dashboard if a failure should occur. The engine has a compact and clean design, and with all fluid filters positioned high on the starboard side, the engine is easy to service and maintain.

### Meeting new emission standards

The high pressure unit injector system in combination with electronics and an advanced combustion system are setting new standards in minimizing noxious emissions and particulates. The engine complies with IMO NO<sub>x</sub>, SAV, US EPA Tier 2, EU RCD and EU IWW.

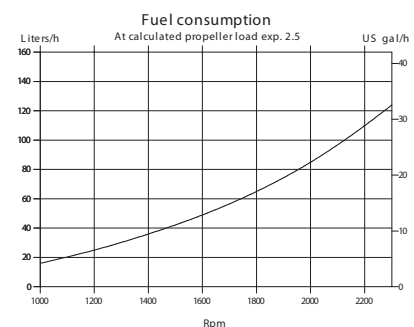
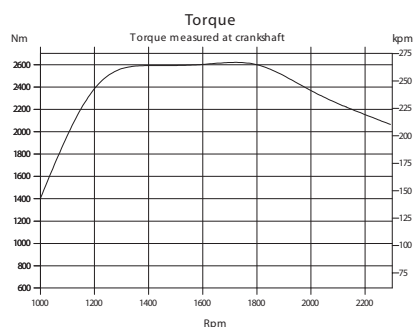
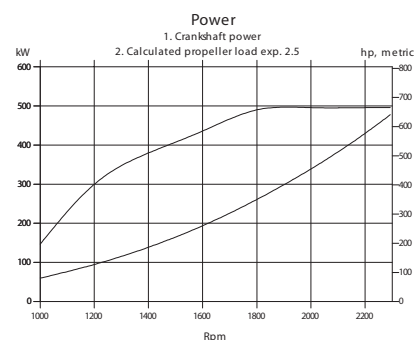

**VOLVO  
PENTA**

# D12-675

## Technical description:

### Engine and block

- Cylinder block and cylinder head made of cast-iron
- One-piece cast-iron cylinder head
- Ladder frame fitted to engine block
- Replaceable wet cylinder liners and valve seats/guides
- Drop forged crankshaft with induction hardened bearing surfaces and fillets with seven main bearings
- Four valve per cylinder layout with overhead camshaft
- Each cylinder features cross-flow inlet and exhaust ducts
- Gallery oil-cooled cast aluminum alloy pistons with three piston rings

### Engine mounting

- Flexible engine mounting (option)

### Lubrication system

- Integrated oil cooler in cylinder block
- Twin full flow oil filter of spin-on type and by-pass filter

### Fuel system

- Electronic Unit Injectors, one per cylinder, vertically positioned at the center in between the four valves
- 6-hole high pressure injector nozzles
- Gear-driven fuel pump, driven by timing gear
- Electronically controlled central processing system (EMS-2 – Engine Management System)
- Electronically controlled injection timing
- Single fine fuel filter of spin-on type, with water separator and water alarm

### Air inlet and exhaust system

- Air filter with replaceable inserts
- Wet exhaust elbow (option)
- Electronically governed wastegate turbo
- Closed crankcase ventilation

### Cooling system

- Freshwater-cooled charge air cooler
- Gear-driven coolant pumps
- Tubular heat exchanger with priority valve

### Electrical system

- 24V/80A alternator

### Instruments/controls (option)

- Complete instrumentation including key switch and interlocked alarm
- EVC monitoring panels for single or twin installations
- Electronic remote control for throttle and shift
- Plug-in connections

### Reverse gear

- ZF325A-EB, ZF311A-EB, and ZF325IV-E, electronically shifted. Low speed as option.

### Optional equipment

Contact your Volvo Penta representative.

Not all models, standard equipment and accessories are available in all countries. All specifications are subject to change without notice.

The engine illustrated may not be entirely identical to production standard engines.

## Technical Data

Engine designation .....	<b>D12D-D MP</b>
No. of cylinders and configuration.....	in-line 6
Method of operation .....	4-stroke, direct-injected, turbocharged diesel engine with aftercooler
Bore/stroke, mm (in.) .....	131/150 (5.16/5.91)
Displacement, l (in <sup>3</sup> ).....	12.1 (740.2)
Compression ratio.....	16.5:1
Dry weight bobtail, kg (lb) .....	1400 (3086)
Dry weight with reverse gear ZF325A-EB, kg (lb)..	1570 (3461)
Crankshaft power, kW (hp) @ 2300 rpm .....	496 (675)
Max. torque, Nm (lb.ft) @ 1400 rpm.....	2590 (1910)
Recommended fuel to conform to.....	ASTM-D975 1-D & 2-D, EN 590 or JIS KK 2204
Specific fuel consumption, g/kWh (lb/hph) @ 2300 rpm .....	210 (0.340)

Technical data according to ISO 3046 Fuel Stop Power and ISO 8665. With fuel having an LHV of 42700 kJ/kg and density of 840 g/liter at 15°C (60°F). Merchant fuel may differ from this specification which will influence engine power output and fuel consumption.

Rating: 5

The engine complies with IMO NOx, SAV, US EPA Tier 2, EU RCD and EU IWW.

## Dimensions D12-675 with ZF311A-EB

Not for installation

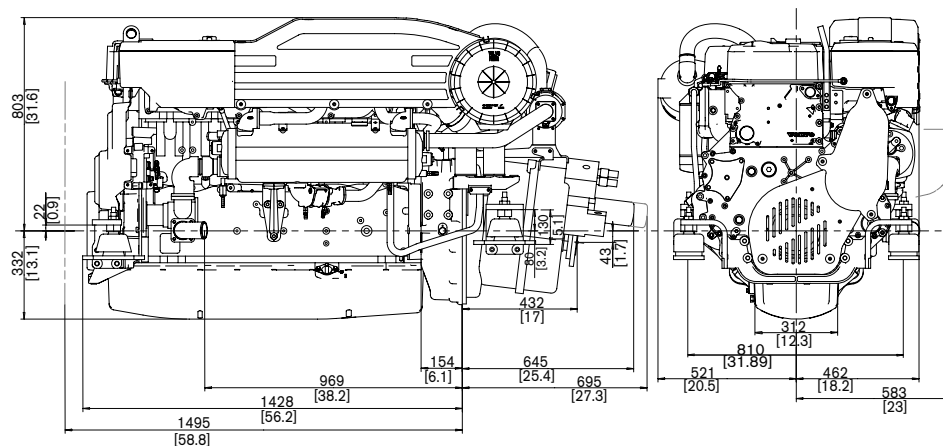

# VOLVO PENTA

**AB Volvo Penta**  
SE-405 08 Göteborg, Sweden  
www.volvopenta.com