

VOLVO PENTA INBOARD DIESEL

D2-40

29.1 kW (39.6 hp) crankshaft power acc. to ISO 8665

Now with
EVC instruments!

D1 and D2 series - a new standard for yacht comfort

The Volvo Penta D1 and D2 series are designed with priority for highest comfort onboard.

Low cruising rpm gives quiet running and low vibrations, and exhaust emissions are extremely low. Compact size means easy installation, and the 115 A alternator with a built-in charging sensor provides rapid charging for onboard electrical needs. Setting a new standard for yacht comfort.

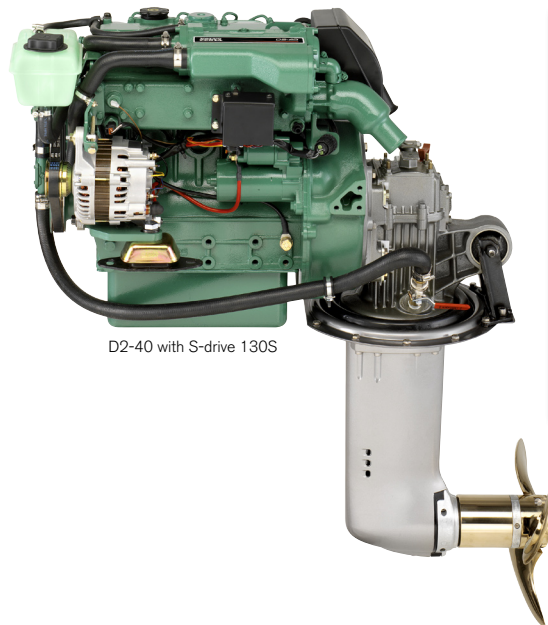

D2-40 with S-drive 130S



The base engine is developed for industrial applications for heavy and medium duty and marinized for the highest marine demands. This guarantees a reliable engine with a long service life.

Now with EVC instruments!

See page two for details.

Service Life

The D2-40 is fitted with freshwater cooling as standard. This reduces internal corrosion and enables the engine to maintain a consistent and optimal working temperature under all conditions.

To avoid galvanic corrosion the engine is equipped with a unique electrical isolation between engine and S-drive.

Comfort

Smooth running with very low vibration levels is achieved through a dynamically balanced design incorporating a flywheel of high rotating mass and high efficiency rubber isolation.

The new engine with re-designed combustion chambers and lower engine speed - 2800-3200 rpm

- together with the new inlet air silencer gives the highest comfort on board. The noise is reduced by 3-4 dBA.

The engine's high torque provides excellent operating characteristics to aid maneuvering, particularly in confined spaces.

Additional on board comfort features are available from an extensive range of matched accessories.

Charging capacity

The new 115A alternator with an electronic sensor makes it possible to use a higher battery capacity and have fully charged batteries on board. Even at idle speed, the alternator gives more than 35A, and at cruising speed it delivers approx. 100A.

Transmissions

Six matched transmission options are available, each built for durability and smooth running.

Environment

An advanced combustion system increases fuel burning efficiency to minimize noxious exhaust emissions and enhance overall enjoyment of boating. The D2-40 is certified according to BSO, SAV, EU RCD and US EPA.

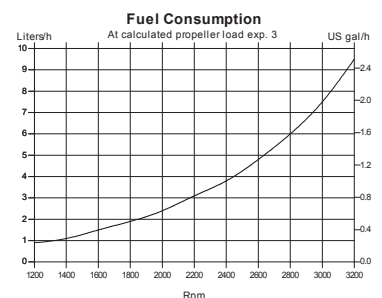
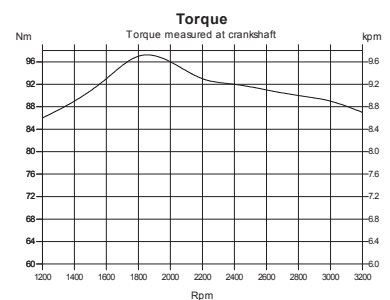
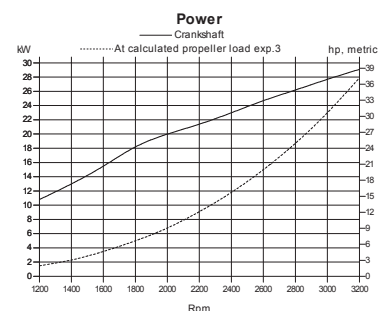

**VOLVO
PENTA**

D2-40

Technical description:

Engine block and head

- Cylinder block and cylinder head manufactured from high grade cast iron. Crankcase features a rigid tunnel block design.
- Chrome molybdenum forged crankshaft, statically and dynamically balanced with integral counterweights. Pistons are cast from high silicon aluminum, are heat treated and fitted with two cast iron, chromium faced compression rings and a single oil ring.
- Replaceable, hardened valve seats
- Elastic coupling on flywheel

Engine mounting

- Tuned front and rear cushion-type rubber mounts. Adjustable.

Lubrication system

- Spin-on fullflow oil filter
- Separate oil scavenger pipe
- Closed circuit crankcase ventilation

Fuel system

- Flange mounted, cam driven in-line injection pump
- Feed pump with hand primer
- Spin-on type fine fuel filter

Exhaust system

- Freshwater cooled exhaust manifold and seawater cooled exhaust elbow

Cooling system

- Freshwater cooling system governed by thermostat
- Tubular heat exchanger with integral expansion tank
- Coolant system prepared for hot water outlet fittings
- Easily accessible sea water pump and impeller

Electrical system

- 12V corrosion-protected electrical system
- 14V/115A marine alternator
- Charging regulator with electronic sensor for voltage drop compensation
- Glow plugs for excellent cold starting
- Electric starter motor
- Electrical stop function
- Extension cable harness with plug-in connection available in various lengths

EVG instruments

- Start/stop panel
- Tachometer with alarms and engine hour counter

Options:

- Separate instruments for:
 - Fuel level
 - Temperature
 - Voltage
- LCD display with multisensor
- NMEA interface presenting engine data on chart plotters

Choice of transmissions:

- Housing of gravity die-cast aluminum alloy
- Mechanical multiple-disc clutch shift
- Safety coupling with built-in overload protection

MS15A – reverse gear with 8° down angle output.

- Ratio 2.14:1/1.96:1 (RH/LH) and 2.63:1/1.96:1 (RH/LH).

MS15L – reverse gear with straight output.

- Ratio 2.14:1/1.96:1 (RH/LH) and 2.63:1/1.96:1 (RH/LH).

S-drive 130S and 130SR for reverse installation of engine. Ratio 2.19:1.

Accessories

- Engine controls and steering systems
- Battery and battery switches
- Hot water systems
- Separate expansion tanks
- Cooling water seacocks, strainers and hoses
- Exhaust systems and hull fittings
- Fuel systems including filters, pipes etc.
- Propeller shaft systems and propellers
- Chemical products – paints, oils, cleaners etc.

Technical Data

Engine designation	D2-40
Crankshaft power, kW (hp)	29.1 (39.6)
Propeller shaft power, kW (hp)	27.9 (38.0)
Engine speed, rpm	2800–3200
Displacement, l (in ³)	1.51 (92.1)
Number of cylinders	4
Bore/stroke, mm (in.)	77/81 (3.03/3.19)
Compression ratio	23.5:1
Dry weight with reverse gear MS15A/MS15L, kg (lb)	178/177 (392/390)
Dry weight with sail drive 130S, kg (lb)	189 (417)

Duty rating: R5

Technical data according to ISO 8665. With fuel having an LHV of 42,700 kJ/kg and density of 840 g/liter at 15°C (60°F). Merchant fuel may differ from this specification which will influence engine power output and fuel consumption. The engine is certified according to BSO, SAV, EU RCD and US EPA.

Dimensions D2-40/MS15A/130S

Not for installation

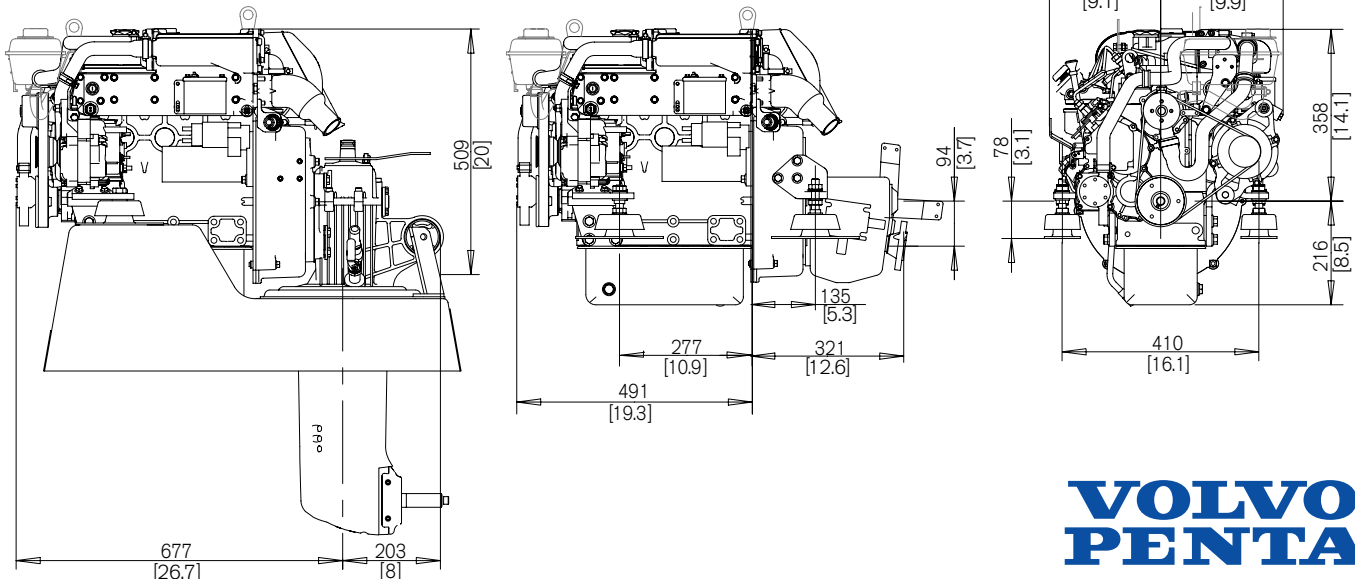

Contact your local Volvo Penta dealer for further information.
 Not all models, standard equipment and accessories are available in all countries. All specifications are subject to change without notice.
 The engine illustrated may not be entirely identical to production standard engines.



AB Volvo Penta
 SE-405 08 Göteborg, Sweden
 www.volvopenta.com