

VOLVO PENTA AQUAMATIC DUOPROP

KAD43P/DPX

6-cylinder, 4-stroke, direct-injected marine diesel engine with charge air compressor, turbocharger, aftercooler and DPX drive. 169 kW (230 hp)*

* Crankshaft power according to ISO 8665

Compressor-charged Hi-Tech engine

Volvo Penta's 6-cylinder KAD43P is a compressor- and turbocharged high performance engine with aftercooler producing high torque at low engine speeds. This means unique acceleration properties and excellent drivability.

Reliable marine engine

KAD43P is a reliable and economic marine engine with considerable power resources developed for planing craft.

The engine is compact and has an advantageous weight to power ratio making it excellent for both single and multi-engine installation.

Direct injection

Direct injection (DI) results in a low thermal load and low fuel consumption compared with swirl chamber engines (IDI) with the same cylinder capacity.

Supercharging

The engine is supercharged with a mechanically driven compressor and an exhaust turbocharger. The compressor – fitted with silencers – supplies compressed air at low engine speeds and while accelerating. The turbo takes over when the charging pressure has reached the proper level.

The interaction of compressor and turbo produces high torque over the whole speed range and this contributes to cleaner exhaust gases and fuel economy giving excellent acceleration and driving characteristics.

Aftercooler

The air heats up and expands when it is compressed. In other words, it takes up more space. The aftercooler cools the compressed and heated air and raises its oxygen content so that the engine can use the fuel more efficiently.

Low exhaust emission levels

The direct injection, supercharging and aftercooler contribute to minimizing noxious exhaust emissions and enhancing overall enjoyment of boating. The engine is certified according to SAV, IMO and IMO US/EPA.

KAD43P with DPX Duoprop drive



Easy to service

The engine is designed for easy maintenance and service.

All the important service points on the engine are conveniently located at the top and the port side.

DPX drive

The DPX drive is designed for speeds in excess of 60 knots with Duoprop's well-known features incorporated into a hydrodynamic lower housing. Equipped with cone clutch for easy and smooth shifting. Pattern-matched spiral bevel gears for optimum strength and minimum gear whine. Break-away shaft coupling to prevent costly drivetrain repairs. Engine coolant water intake on the drive. Exhaust through propeller hub, cavitation plate and transom shield for maximum quietness and low power losses.

The DPX is equipped as standard with a unique integrated hydraulic power steering system to ensure precise control and optimum driving comfort. The Xact steering consists of two hydraulic steering cylinders on the drive-transom shield, a helm steering pump (2.7 turns lock to lock), power steering pump and necessary hoses (6 m) and fittings for a complete installation. The

drive is also equipped with easily maneuvered hydraulic power trim for obtaining the best running position at different sea conditions.

For precise trim indication of the drive a mechanical trim indicator is available.

For optimized performance three sets of stainless steel propellers are available. The drive in combination with KAD43P is suitable for both single and multi-engine installations in speeds above 40 knots.

Comprehensive service network

Volvo Penta has a well-established network of authorized service dealers in more than 100 countries throughout the world. These service centers offer Genuine Volvo Penta Parts as well as skilled personnel to ensure that you enjoy the best possible service.

**VOLVO
PENTA**

KAD43P/DPX

Technical description:

Engine and block

- Cylinder block and cylinder head made of cast iron for good corrosion resistance and long service life
- Oil-cooled pistons with two compression rings and one oil scraper ring
- Replaceable wet cylinder liners
- Replaceable valve seats
- Seven-bearing crankshaft

Engine mounting

- Flexible mounting which provides sound and vibration insulation. The engine has two adjustable rubber mounts in front and rubber suspension between flywheel housing and transom shield

Lubrication system

- Pressure lubrication system with easily replaced full-flow oil filter on the side of the engine
- Tubular oil cooler that can be cleaned

Fuel system

- Rotor-type injection pump with a mechanical governor for accurate speed control
- Smoke limiter
- Fine filter with water separator
- Feed pump with hand primer
- Electrically-operated stopping device

Air inlet and exhaust system

- Inlet system designed to produce optimal air rotation which provides perfect combustion. This results in high power and low fuel consumption.
- Air inlet silencer with replaceable filter
- Closed crankcase vent system
- Air silencer on inlet and outlet side of compressor
- Seawater-cooled exhaust elbow of cast iron with a stainless steel insert
- Complete connection for exhaust outlet through the drive
- Exhaust-driven freshwater-cooled turbocharger
- Mechanically driven compressor

Cooling system

- Thermostatically regulated freshwater cooling
- Tubular heat exchanger with separate transparent expansion tank
- Coolant system prepared for hot water outlet
- Seawater strainer and easily accessible impeller pump

Electrical system

- 12V corrosion-protected electrical system, complete with instrumentation
- 14V/60A marine alternator
- Charging regulator with battery sensor for voltage drop compensation
- The alternator is prepared for a bulkhead-mounted double-diode set which auto-

- atically distributes the charge current to two separate battery circuits
- Automatic fuse with manual reset
- Starter motor power 3.0 kW
- Extension cable harness with plug-in connection available in various lengths

Instrument panel:

Complete panel or separate instruments and harness available.

DPX Drive

- Cone clutch
- Coolant water intake for the engine located at the lower part of the drive
- Pattern-matched spiral bevel gears
- Through-hub exhaust
- Overload protection sleeve (break-away coupling)
- The drive can be tilted 43°
- The drive can be turned 23° in each direction
- Built-in kick-up function to reduce possible damage, in the event the drive strikes an underwater object

Power Trim

- Electrically operated hydraulic system for trimming the drive for best driving comfort
- For precise trim indication of the drive a mechanical trim indicator is available

Accessories

An extensive range of accessories – for more information, please see Accessory catalogs.

Technical Data

Engine designation.....	KAD43P
Crankshaft power, kW (hp).....	169 (230)
Propeller shaft power, kW (hp).....	161 (218)
Engine speed, rpm.....	3900
Displacement, l (in ³).....	3.6 (219)
Number of cylinders.....	6
Bore/stroke, mm (in.).....	92/90 (3.62/3.54)
Compression ratio.....	17.8:1
Volvo Penta Duoprop drive.....	DPX
Ratio.....	1.78 and 1.68:1
Dry weight with DPX, incl. prop., kg (lb).....	582 (1283)

Duty rating: R5-R4

Technical data according to ISO 8665. Fuel with a lower calorific value of 42,700 kJ/kg and density of 840 g/liter at 15°C (60°F). Merchant fuel may differ from this specification which will influence engine power output and fuel consumption. The engine is certified according to SAV, IMO and IMO US/EPA.

Dimensions

Not for installation

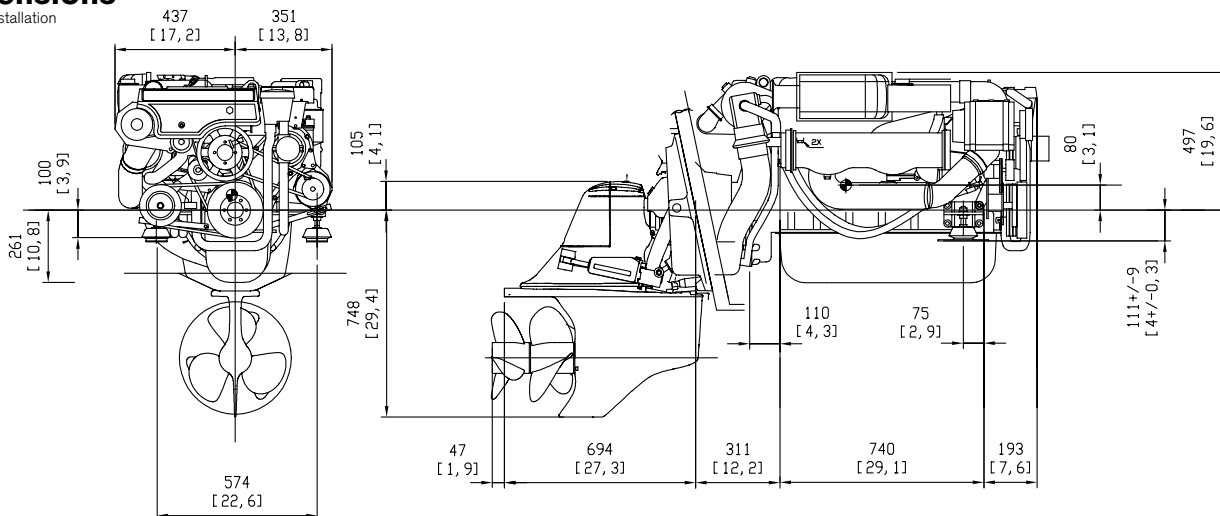

Contact your local Volvo Penta dealer for further information.

Not all models, standard equipment and accessories are available in all countries. All specifications are subject to change without notice.

The engine illustrated may not be entirely identical to production standard engines.

VOLVO PENTA

AB Volvo Penta
SE-405 08 Göteborg, Sweden
www.volvopenta.com