

VOLVO PENTA AQUAMATIC DUOPROP KAD44PEDC/DP

6-cylinder, 24-valve, direct-injected marine diesel engine with charge air compressor, turbocharger, aftercooler and Duoprop drive. 191 kW (260 hp)*

* Crankshaft power according to ISO 8665

Hi-Tech marine engine

Volvo Penta's 6-cylinder KAD44PEDC is a compressor- and turbocharged high performance engine with unique acceleration properties and excellent drivability.

Innovative EDC

Equipped with EDC (Electronic Diesel Control) – an electronically controlled processing system which optimizes engine performance. The system determines the precise quantity of fuel required at any given moment, taking full account of variation in operating temperatures, air pressure and other contributing factors.

The EDC system includes electric control and wiring giving precise and smooth operation with no noise transmitted along the cables.

Shifting of the drive is performed by means of an electronic actuator integrated in the system.

High output, excellent power/weight ratio

KAD44PEDC is a reliable and economic direct-injected marine engine with considerable power resources, developed for planing craft.

The engine is compact and has an advantageous weight to power ratio making it excellent for both single and multi-engine installation.

The compressor – fitted with silencers – is controlled by the EDC unit and acts as a "torque controller". It supplies compressed air at low engine speed and while accelerating when the extra torque is needed.

The interaction of compressor and turbo produces high torque over the whole speed range, and this contributes to cleaner exhaust gases and fuel economy giving excellent acceleration and driving characteristics.

Low exhaust emission levels

The 4-valve technology and the advanced combustion system minimize noxious exhaust emissions and enhance overall enjoyment of boating. The engine is certified according to BSO II, SAV, IMO and IMO US/EPA.



KAD44PEDC with DP-E
Duoprop drive

Total driveline fully matched and tested from a single supplier

The combination of power and unbeaten propulsion efficiency ensures maximum thrust both during acceleration and for top speed performance.

The DP drive with its twin counter-rotating propellers produces a harmonious drive unit with unbeatable characteristics in the boat in terms of speed, acceleration and fuel economy.

It also produces less noise and vibrations, better steering and maneuvering characteristics, better grip in the water and a shorter time to planing compared with single propeller systems.

The drive features standard power steering for maximum driving comfort.

Easy installation and maintenance

Plug-in electrical connectors instead of conventional cabling. The EDC system makes planning and performing multi-installations easy, allowing up to eight control stations.

The EDC system includes a self-diagnostic facility. Easily accessible service and maintenance points contribute to the ease of service of the engine.

Comprehensive service network

Volvo Penta has a well-established network of authorized service dealers in more than 100 countries throughout the world. These service centers offer Genuine Volvo Penta Parts as well as skilled personnel to ensure that you enjoy the best possible service.

Technical description:

Engine and block

- Cylinder block and cylinder head made of cast iron for good corrosion resistance and long service life
- 4-valve technology
- Oil-cooled pistons with two compression rings and one oil scraper ring
- Replaceable wet cylinder liners
- Replaceable valve seats
- Seven-bearing crankshaft

**VOLVO
PENTA**

KAD44PEDC/DP

Engine mounting

- Flexible mounting providing sound and vibration insulation. Two adjustable rubber mounts in front and rubber suspension between flywheel housing and transom shield

Lubrication system

- Pressure lubrication system with easily replaceable full-flow oil filter
- Tubular oil cooler that can be cleaned

Fuel system

- Rotor-type injection pump with electronic actuator
- EDC unit for processing the input for precise engine governing
- Two-stage injectors
- Fine filter with water separator
- Feed pump with hand primer
- Electrically operated stopping device

Air inlet and exhaust system

- Inlet system designed to produce optimal air rotation which provides perfect combustion
- Air inlet silencer with replaceable filter
- Crankcase gases vented into the air inlet
- Seawater-cooled exhaust elbow of cast iron with a stainless steel insert
- Complete connection for exhaust outlet through the drive

- Exhaust-driven freshwater-cooled turbo-charger
- Belt-driven compressor with silencer of absorption type on both inlet and outlet port

Cooling system

- Thermostatically regulated freshwater cooling
- Tubular heat exchanger with separate transparent expansion tank
- Coolant system prepared for hot water outlet
- Seawater strainer and easily accessible impeller pump

Electrical system

- 12V two-pole electrical system
- 14V/60A marine alternator with Zener-diodes to protect entire system from peak voltage
- Charging regulator with battery sensor for voltage drop compensation
- Automatic fuses with manual reset
- Starter motor power 3.0 kW

Instruments/control

- Complete engine panel with key switch, instruments and alarm panel or separate instruments
- Analog or digital instrument for drive trim angle

- EDC monitoring panels and multistation units
- Electronic remote control for EDC
- Plug-in cables

Drive

- Complete with transom shield, flywheel cover and installation components
- The drive can be tilted up by 42°
- Protective zinc anodes prevent corrosion
- Coolant water inlet at the front of the drive
- Built-in kick-up function to reduce possible damage, in the event the drive strikes an underwater object
- Electrical shifting performed by electronic actuator controlled by the EDC unit
- Power Trim is an electrically operated hydraulic system for trimming the drive for best driving comfort

Accessories

An extensive range of accessories are available. For detailed information, please see Accessory catalogs.

Contact your local Volvo Penta dealer for further information.

Not all models, standard equipment and accessories are available in all countries. All specifications are subject to change without notice.

The engine illustrated may not be entirely identical to production standard engines.

Technical Data

Engine designation	KAD44P EDC
Crankshaft power, kW (hp)	191 (260)
Propeller shaft power, kW (hp).....	182 (248)
Engine speed, rpm.....	3800
Displacement, l (in ³)	3.6 (219)
Number of cylinders	6
Bore/stroke, mm (in.).....	92/90 (3.62/3.54)
Compression ratio	16.5:1
Volvo Penta Duoprop drive.....	DP-E
Ratio.....	1.68:1
Dry weight with DP, incl. prop., kg (lb).....	572 (1261)

Duty rating: R5

Technical data according to ISO 8665. Fuel with a lower calorific value of 42,700 kJ/kg and density of 840 g/liter at 15°C (60°F). Merchant fuel may differ from this specification which will influence engine power output and fuel consumption.

The engine is certified according to BSO II, SAV, IMO and IMO US/EPA.

Dimensions

Not for installation

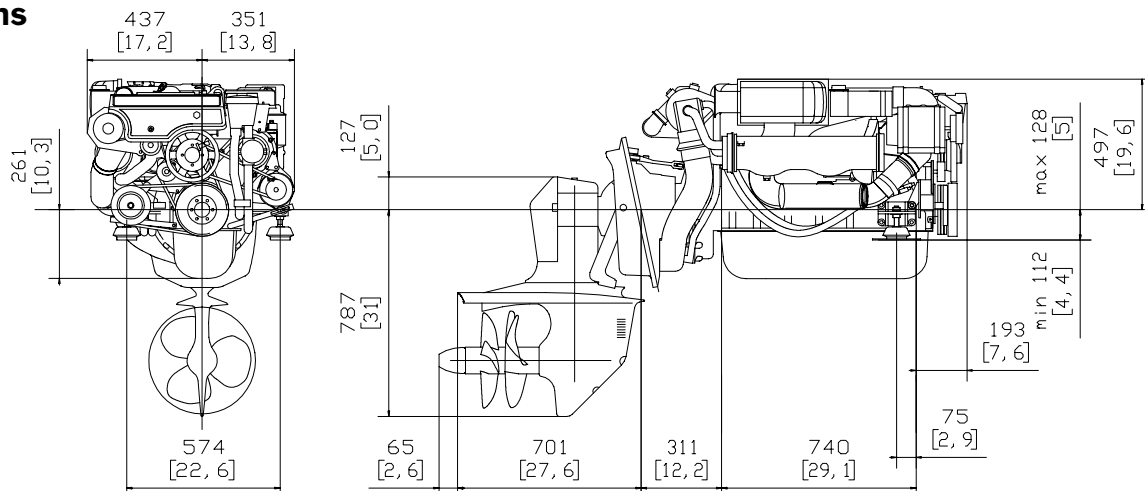

VOLVO PENTA

AB Volvo Penta
SE-405 08 Göteborg, Sweden
www.volvopenta.com