

VOLVO PENTA AQUAMATIC DUOPROP KAD44PEDC/DPX

6-cylinder, 24-valve, direct-injected marine diesel engine with charge air compressor, turbocharger, aftercooler and DPX drive. 191 kW (260 hp)*

* Crankshaft power according to ISO 8665

Hi-Tech marine engine

Volvo Penta's 6-cylinder KAD44PEDC is a compressor- and turbocharged high performance engine with unique acceleration properties and excellent drivability.

Innovative EDC

Equipped with EDC (Electronic Diesel Control) – an electronically controlled processing system which optimizes engine performance. The system determines the precise quantity of fuel required at any given moment, taking full account of variation in operating temperatures, air pressure and other contributing factors.

High output, excellent power/weight ratio

KAD44PEDC is a reliable and economic direct-injected marine engine with considerable power resources, developed for planing craft.

The engine is compact and has an advantageous weight to power ratio making it excellent for both single and multi-engine installation.

The compressor – fitted with silencers – is controlled by the EDC unit and acts as a "torque controller". It supplies compressed air at low engine speed and while accelerating when the extra torque is needed.

The interaction of compressor and turbo produces high torque over the whole speed range, and this contributes to cleaner exhaust gases and fuel economy giving excellent acceleration and driving characteristics.

Low exhaust emission levels

The 4-valve technology and the advanced combustion system minimize noxious exhaust emissions and enhance overall enjoyment of boating. The engine is certified according to BSO II, SAV, IMO and IMO US/EPA.

DPX drive

The DPX drive is designed for speeds in excess of 60 knots with Duoprop's well-known features incorporated into a hydrodynamic lower housing. Equipped with cone clutch for easy and smooth shift-



KAD44PEDC with DPX
Duoprop drive

ing. Pattern-matched spiral bevel gears for optimum strength and minimum gear whine. Break-away shaft coupling to prevent costly drivetrain repairs. Engine coolant water intake on the drive. Exhaust through propeller hub, cavitation plate and transom shield for maximum quietness and low power losses.

The DPX is equipped as standard with a unique integrated hydraulic power steering system to ensure precise control and optimum driving comfort. The Xact steering consists of two hydraulic steering cylinders on the drive-transom shield, a helm steering pump (2.7 turns lock to lock), power steering pump and necessary hoses (6 m) and fittings for a complete installation. The drive is also equipped with easily maneuvered hydraulic power trim for obtaining the best running position at different sea conditions.

For precise trim indication of the drive a mechanical trim indicator is available.

For optimized performance three sets of stainless steel propellers are avail-

able. The drive in combination with KAD44PEDC is suitable for both single and multi-engine installations in speeds above 40 knots.

Comprehensive service network

Volvo Penta has a well-established network of authorized service dealers in more than 100 countries throughout the world. These service centers offer Genuine Volvo Penta Parts as well as skilled personnel to ensure that you enjoy the best possible service.

Technical description:

Engine and block

- Cylinder block and cylinder head made of cast iron for good corrosion resistance and long service life
- 4-valve technology
- Oil-cooled pistons with two compression rings and one oil scraper ring
- Replaceable wet cylinder liners
- Replaceable valve seats
- Seven-bearing crankshaft

**VOLVO
PENTA**

KAD44PEDC/DPX

Engine mounting

- Flexible mounting providing sound and vibration insulation

Lubrication system

- Pressure lubrication system with easily replaceable full-flow oil filter
- Tubular oil cooler that can be cleaned

Fuel system

- Rotor-type injection pump with electronic actuator
- EDC unit for processing the input for precise engine governing
- Two-stage injectors
- Fine filter with water separator
- Feed pump with hand primer
- Electrically operated stopping device

Air inlet and exhaust system

- Inlet system designed to produce optimal air rotation which provides perfect combustion
- Air inlet silencer with replaceable filter
- Crankcase gases vented into the air inlet
- Seawater-cooled exhaust elbow of cast iron with a stainless steel insert
- Complete connection for exhaust outlet through the drive
- Exhaust-driven freshwater-cooled turbo-charger

- Belt-driven compressor with silencer on both inlet and outlet port

Cooling system

- Thermostatically regulated freshwater cooling
- Tubular heat exchanger with separate transparent expansion tank
- Coolant system prepared for hot water outlet
- Seawater strainer and easily accessible impeller pump

Electrical system

- 12V two-pole electrical system
- 14V/60A marine alternator with Zener-diodes to protect entire system from peak voltage
- Charging regulator with battery sensor for voltage drop compensation
- Automatic fuses with manual reset
- Starter motor power 3.0 kW

Instruments/control

- Complete panel or separate instruments
- EDC monitoring panels and multistation units
- Electronic remote control for EDC
- Plug-in cables

DPX drive

- Cone clutch
- Coolant water intake for the engine located at the lower part of the drive
- Pattern-matched spiral bevel gears
- Through-hub exhaust

- Overload protection sleeve (break-away coupling)

- The drive can be tilted 43°
- The drive can be turned 23° in each direction
- Built-in kick-up function to reduce possible damage, in the event the drive strikes an underwater object
- Electrical shifting performed by electronic actuator controlled by the EDC unit
- Power Trim is an electronically operated hydraulic system for trimming the drive for best driving comfort
- For precise trim indication of the drive a mechanical trim indicator is available

Accessories

An extensive range of accessories are available. For detailed information, please see Accessory catalogs.

Contact your local Volvo Penta dealer for further information.

Not all models, standard equipment and accessories are available in all countries. All specifications are subject to change without notice.

The engine illustrated may not be entirely identical to production standard engines.

Technical Data

Engine designation	KAD44P EDC
Crankshaft power, kW (hp)	191 (260)
Propeller shaft power, kW (hp).....	182 (248)
Engine speed, rpm.....	3800
Displacement, l (in ³)	3.6 (219)
Number of cylinders	6
Bore/stroke, mm (in.).....	92/90 (3.62/3.54)
Compression ratio	16.5:1
Volvo Penta Duoprop drive.....	DPX
Ratio.....	1.68:1 and 1.59:1
Dry weight with DPX, incl. prop., kg (lb).....	584 (1288)

Duty rating: R5

Technical data according to ISO 8665. Fuel with a lower calorific value of 42,700 kJ/kg and density of 840 g/liter at 15°C (60°F). Merchant fuel may differ from this specification which will influence engine power output and fuel consumption.

The engine is certified according to BSO II, SAV, IMO and IMO US/EPA.

Dimensions

Not for installation

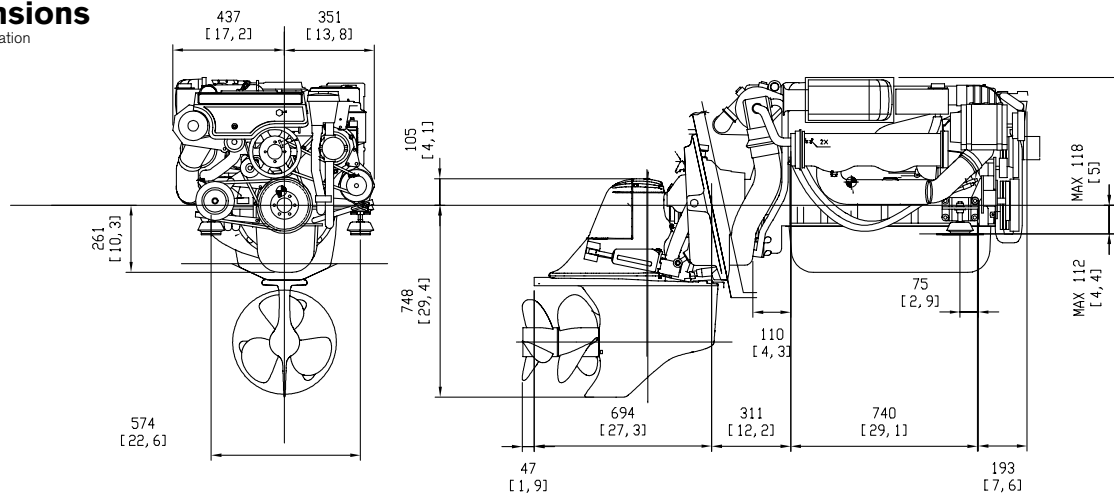

VOLVO PENTA

AB Volvo Penta
SE-405 08 Göteborg, Sweden
www.volvopenta.com