

VOLVO PENTA INBOARD DIESEL

KAMD43P

6-cylinder, 4-stroke, direct-injected marine diesel engine with charge air compressor, turbocharger, aftercooler and reverse gear. 169 kW (230 hp)*

* Crankshaft power according to ISO 8665

Compressor-charged Hi-Tech engine

Volvo Penta's 6-cylinder KAMD43P is a compressor- and turbocharged high performance engine with aftercooler producing high torque at low engine speeds. This means unique acceleration properties and excellent drivability.

Reliable marine engine

KAMD43P is a reliable and economic marine engine with considerable power resources, developed for planing craft.

The engine is compact and has an advantageous weight to power ratio making it excellent for both single and multi-engine installation.

Direct injection

Direct injection (DI) results in a low thermal load and low fuel consumption compared with swirl chamber engines (IDI) with the same cylinder capacity.

Supercharging

The engine is supercharged with a mechanically driven compressor and an exhaust turbocharger. The compressor – fitted with silencers – supplies compressed air at low engine speeds and while accelerating. The turbo takes over when the charging pressure has reached the proper level.

The interaction of compressor and turbo produces high torque over the whole speed range and this contributes to cleaner exhaust gases and fuel economy giving excellent acceleration and driving characteristics.

Aftercooler

Air heats up and expands when it is compressed. In other words, it takes up more space. The aftercooler cools the compressed and heated air and raises its oxygen content so that the engine can use the fuel more efficiently.

Low exhaust emission levels

The direct injection, supercharging and aftercooler contribute to minimizing noxious exhaust emissions and enhancing overall enjoyment of boating. The engine is certified according to SAV, IMO and IMO US/EPA.

KAMD43P with HS63A reverse gear

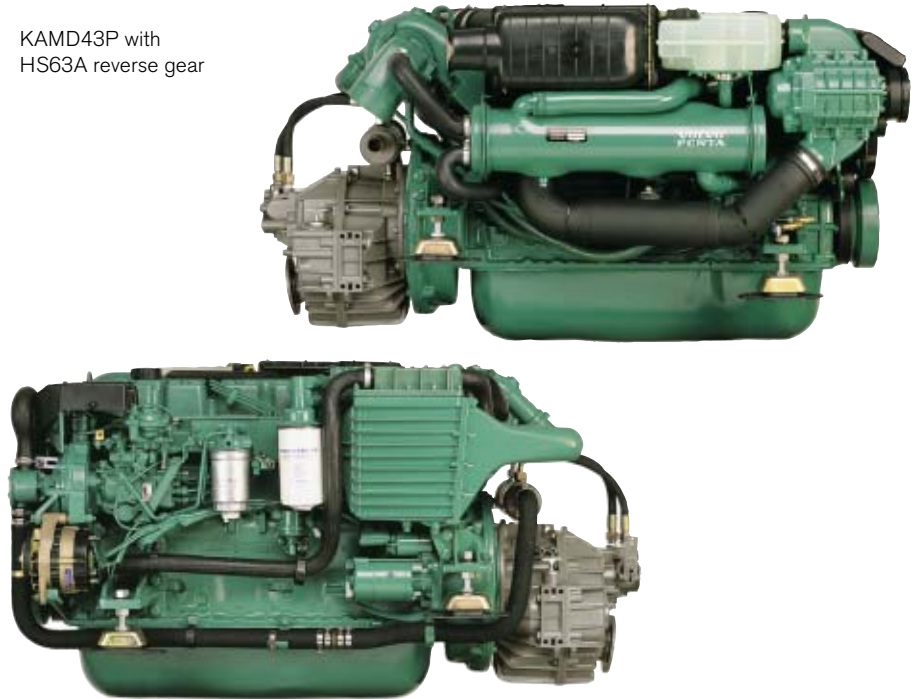

Easy to service

The engine is designed for easy maintenance and service.

All the important service points on the engine are conveniently located at the top and the port side.

Reverse gear

Volvo Penta's hydraulically shifted reverse gear has been specially developed with a view to increasing the standard of comfort on board in terms of quiet running, greater reliability and enhanced efficiency.

These benefits originate from a hydraulic shifting mechanism and a gear technology that uses bevel gears throughout the gear train.

The combination of 8° down angle, large drop center and small dimensions provides for optimized installations.

A trolling valve kit is available to meet special demands, e.g. for sportfishing.

At Volvo Penta, focus is on developing the complete drive line ensuring perfectly matched engine/transmission packages for high torque, operational reliability, reduction of engine noise and vibrations.

Comprehensive service network

Volvo Penta has a well-established network of authorized service dealers in more than 100 countries throughout the world. These service centers offer Genuine Volvo Penta Parts as well as skilled personnel to ensure that you enjoy the best possible service.

Technical description:

Engine and block

- Cylinder block and cylinder head made of cast iron for good corrosion resistance and long service life
- Oil-cooled pistons with two compression rings and one oil scraper ring
- Replaceable wet cylinder liners
- Replaceable valve seats
- Seven-bearing crankshaft

Engine mounting

- Elastic suspension consisting of 4 rubber pads with adjustable anchorage plates for dampening of sound and vibration

**VOLVO
PENTA**

KAMD43P

Lubrication system

- Pressure lubrication system with easily replaced full-flow oil filter on the side of the engine
- Tubular oil cooler that can be cleaned

Fuel system

- Rotor-type injection pump with a mechanical governor for accurate speed control
- Smoke limiter
- Fine filter with water separator
- Feed pump with hand primer
- Electrically-operated stopping device

Air inlet and exhaust system

- Inlet system designed to produce optimal air rotation which provides perfect combustion. This results in high power and low fuel consumption.
- Air inlet silencer with replaceable filter
- Closed crankcase vent system
- Air silencer on inlet and outlet side of compressor
- Seawater-cooled exhaust elbow of cast iron with a stainless steel insert
- Exhaust-driven freshwater-cooled turbo-charger
- Mechanically driven compressor

Cooling system

- Thermostatically regulated freshwater cooling
- Tubular heat exchanger with separate transparent expansion tank
- Coolant system prepared for hot water outlet
- Easily accessible impeller pump

Electrical system

- 12V corrosion-protected electrical system, complete with instrumentation
- 14V/60A marine alternator
- Charging regulator with battery sensor for voltage drop compensation
- The alternator is prepared for a bulkhead-mounted double-diode set which automatically distributes the charge current to two separate battery circuits
- Automatic fuse with manual reset
- Starter motor power 3.0 kW
- Extension cable harness with plug-in connection available in various lengths

Instrument panel:

Separate instruments and harness or complete panel fitted with:

- Key switch
- Temperature gauge
- Instrument lighting
- Alarm for temperature, oil pressure and charging
- Voltmeter
- Rev counter
- Hour meter
- Oil pressure gauge
- Alarm test

Reverse gear

- Both down angled and V-drive configurations
- Bevel gears which results in smooth running at all speeds
- Hydraulically operated clutch for smooth shifting
- Matched drop center and 8° down angle for compact installation and minimum propeller shaft angle
- When under sail propeller shaft can rotate 24 hours without engine start
- Seawater-cooled oilcooler
- Trolling valve kit available

Accessories

An extensive range of accessories for:

- Fuel system
- Control system
- Electric system
- Propellers
- Cooling system
- Instruments
- Comfort & Safety
- Maintenance

For detailed information, please see Accessory catalogs.

Contact your local Volvo Penta dealer for further information.

Not all models, standard equipment and accessories are available in all countries. All specifications are subject to change without notice.

The engine illustrated may not be entirely identical to production standard engines.

Technical Data

Engine designation.....	KAMD43P
Crankshaft power, kW (hp).....	169 (230)
Propeller shaft power, kW (hp).....	163 (221)
Engine speed, rpm.....	3900
Displacement, l (in ³).....	3.6 (219)
Number of cylinders.....	6
Bore/stroke, mm (in.).....	92/90 (3.62/3.54)
Compression ratio.....	17.8:1
Dry weight with HS63A, kg (lb).....	534 (1177)
Duty rating/Reverse gear:	
HS45A , RH (standard) or LH.....	R5
Ratio:.....	2.43:1, 2.03:1, 1.51:1
HS63A	R5-R4
Ratio RH (standard):.....	2.52:1, 2.04:1, 1.56:1
LH:.....	2.53:1, 2.02:1, 1.58:1
HS63V	R5-R4
Ratio RH (standard):.....	2.48:1, 2.00:1, 1.56:1
LH:.....	2.53:1, 2.03:1, 1.57:1

Technical data according to ISO 8665. Fuel with a lower calorific value of 42,700 kJ/kg and density of 840 g/liter at 15°C (60°F). Merchant fuel may differ from this specification which will influence engine power output and fuel consumption.
N.B. The product can also be used in an application with a higher rating than stated, e.g. R3 can be used for R4 or R5.
The engine is certified according to SAV, IMO and IMO US/EPA.

Dimensions KAMD43P/HS63A

Not for installation

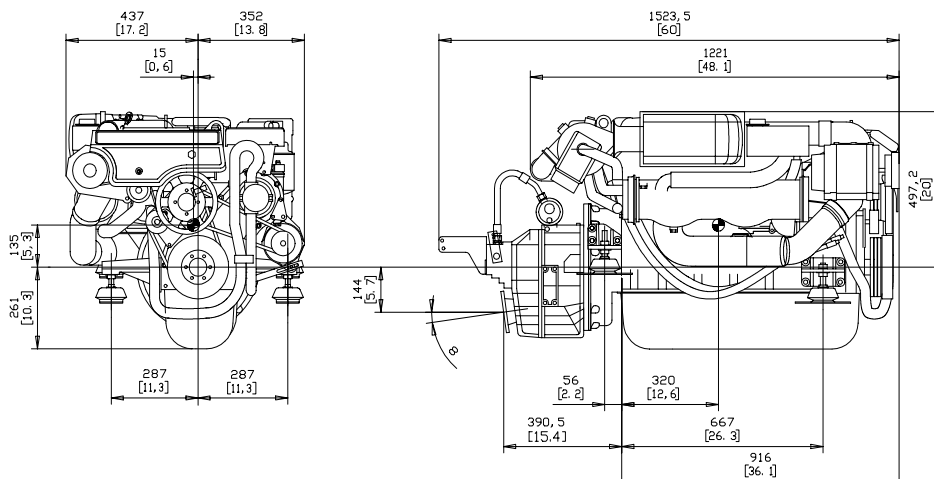

VOLVO PENTA

AB Volvo Penta
SE-405 08 Göteborg, Sweden
www.volvopenta.com