

VOLVO PENTA INBOARD DIESEL TAMD63L/P

6-cylinder, 4-stroke, direct-injected, turbocharged marine diesel engine with aftercooler – crankshaft power* 173–272 kW (235–370 hp)

* Power rating – see Technical Data

Compact performance

The TAMD63 is a powerful, reliable and economical marine diesel engine, specially developed for fast planing and semi-planing craft. The installation volume is approx. 30% less than that of the preceding engines.

The engine has been specifically constructed for efficient turbocharging with a high power/fuel consumption ratio. Thus offering excellent fuel economy.

Durability and low noise levels

The Volvo Penta in-line six is a well-balanced unit with smooth and vibration-free operation and low noise levels. The torsionally-rigid cylinder block and crank mechanism are designed to withstand many hours of demanding operation.

To maintain a stable working temperature in cylinders and combustion chambers, the engine is equipped with piston cooling and freshwater-cooled oil cooler.

The engine is also fitted with replaceable cylinder liners and valve seats/guides to ensure maximum durability and service life.

Low exhaust emission levels

A low-air rotation combustion technique, producing optimum airflow, and a high-pressure injection system with 5-hole injectors ensure an optimum fuel-air mixture. This greatly contributes to reduced noxious exhaust emission levels. The direct injection (DI) system ensures a low fuel consumption. The engines are certified according to SAV, IMO and IMO US/EPA.

Marine electrics

The two-pole electrical system is specially adapted to demanding marine environments with remote and flex-mounted senders as well as moisture-proof connectors.

Ease of service and maintenance

The single poly-V drive belt driving the alternator and freshwater circulation pump (a single service point at the front of the engine) together with the oil filter and the



TAMD63L/P with
ZF 220A reverse gear

by-pass filter contribute to ease of service and maintenance.

Comprehensive service network

Volvo Penta has a well-established network of authorized service dealers in more than 100 countries throughout the world. These service centers offer Genuine Volvo Penta Parts as well as skilled personnel to ensure that you enjoy the best possible service.

Technical description:

Engine and block

- Cylinder block and cylinder heads made of cast iron alloy
- Two cylinder heads. A flame barrier protects the cylinder head gasket.
- Replaceable wet cylinder liners and valve seats/guides
- Nitrocarburized crankshaft with seven main bearings
- Oil-cooled forged aluminum pistons
- Three piston rings, the upper of which is of the keystone type

Lubrication system

- Freshwater-cooled oil cooler
- Oil filter and by-pass filter of spin-on type
- Oil dipsticks on both sides of oil sump

Fuel system

- Fuel injection pump with centrifugal governor, smoke limiter and fuel feed pump
- Five-hole injectors
- Twin fine fuel filters of spin-on type
- Electrical fuel valve stopping device

Turbocharger

- Freshwater-cooled turbocharger
- Wastegate for high torque at low speed (TAMD63P)

Cooling system

- Tubular heat exchanger with integrated expansion tank or 2-circuit keel cooling
- Seawater-cooled tubular aftercooler
- Poly-V driven freshwater pump and gear-driven seawater pump with neoprene impeller

Electrical system

- 12 V or 24 V electrical system incl. alternator, 60 and 40 A respectively, with charging sensor
- Rubber suspended electrical terminal box with semi-automatic fuses

**VOLVO
PENTA**

TAMD63L/P

Technical Data

Engine designation TAMD63L/P
 No. of cylinders and configuration in-line 6
 Method of operation 4-stroke,
 direct-injected, turbocharged
 diesel engine with aftercooler
 Bore, mm (in.) 98.42 (3.87)
 Stroke, mm (in.) 120 (4.7)
 Displacement, l (cu.in.) 5.46 (333)
 Compression ratio 15:1
 Dry weight TAMD63L, kg (lb) 742 (1636)
 Dry weight incl. ZF 220A, kg (lb) 821 (1810)
 Dry weight TAMD63P, kg (lb) 754 (1662)
 Dry weight incl. ZF 220A, kg (lb) 833 (1836)
 Crankshaft power TAMD63L,
 Rating 3, kW (hp) 2800 rpm¹⁾ 234 (318)
 Rating 3, kW (hp) 2800 rpm²⁾ 228 (310)
 Rating 2, kW (hp) 2500 rpm²⁾ 173 (235)
 Crankshaft power TAMD63P,
 Rating 4, kW (hp) 2800 rpm¹⁾ 272 (370)
 Rating 4, kW (hp) 2800 rpm²⁾ 265 (360)
 Torque TAMD63L,
 Rating 3, Nm (lbf.ft) 2800 rpm²⁾ 778 (574)
 Rating 2, Nm (lbf.ft) 2500 rpm²⁾ 663 (489)
 Torque TAMD63P,
 Rating 4, Nm (lbf.ft) 2800 rpm²⁾ 904 (667)
 Recommended fuel to
 conform to ASTM-D975 1-D & 2-D,
 EN 590 or JIS KK 2204

Specific fuel consumption TAMD63L,
 R3, g/kWh (lb/hph) 2800 rpm²⁾ 235 (0.381)
 R2, g/kWh (lb/hph) 2500 rpm²⁾ 228 (0.369)
 Specific fuel consumption TAMD63P,
 R4, g/kWh (lb/hph) 2800 rpm²⁾ 248 (0.402)

1) Fuel temperature 25 °C (77 °F)
 2) Fuel temperature 40 °C (104 °F)

The diagrams relate to a fuel temperature of 25 °C (77 °F)

Technical data according to ISO 3046 Fuel Stop Power and ISO 8665. Fuel with a lower calorific value of 42700 kJ/kg and density of 840 g/liter at 15 °C (60 °F). Merchant fuel may differ from this specification which will influence engine power output and fuel consumption.

The engines are certified according to SAV, IMO and IMO US/EPA.

N.B. The product can also be used in an application with a higher rating than stated, e.g. R3 can be used for R4 or R5.

Optional equipment:

Engine

- Flexible suspension for the engine and reverse gear

Lubrication system

- Bulkhead-mounted full-flow oil filter
- Electrically operated oil drain pump

Fuel system

- Fuel filter with water separator

Exhaust system

- Exhaust elbow, wet
- Exhaust riser, wet
- Exhaust boot, wet
- Exhaust elbow, dry
- Silencer, dry
- Flexible compensator, dry

Cooling system

- Seawater strainer
- Hot water outlet
- Separate expansion tank

Electrical system

- 12V 130A or 24V 100A extra alternators
- Various instrument panels
- Cable harness in different lengths

Power transmission

- PTO crankshaft front end, type stub shaft incl. universal bracket
- Hydraulic pump for steering and other duties

Reverse gear

- ZF 220A
- ZF 220IV
- MG 5061A
- MG 5062V

Other equipment

- Belt guard
- White-painted engine and reverse gear

Contact your local Volvo Penta dealer for further information.

Not all models, standard equipment and accessories are available in all countries. All specifications are subject to change without notice.

The engine illustrated may not be entirely identical to production standard engines.

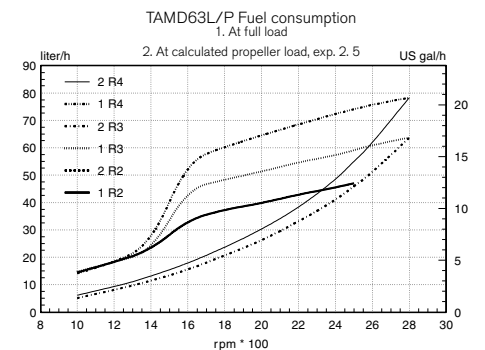
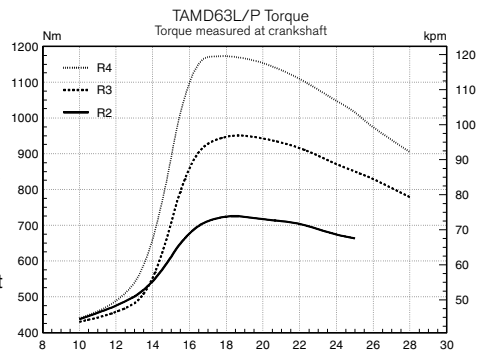
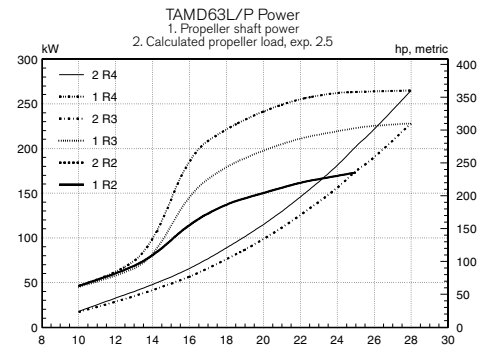

Dimensions TAMD63L/P with ZF 220A

Not for installation

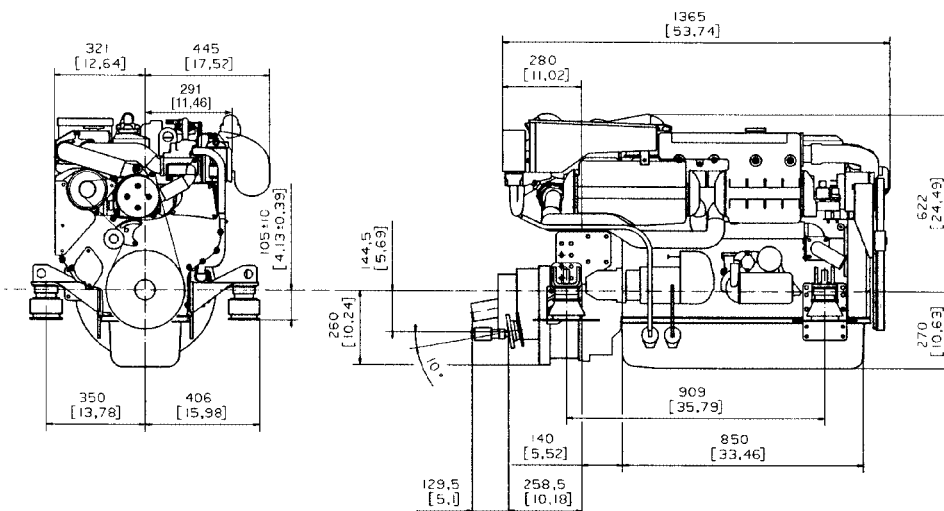

VOLVO PENTA

AB Volvo Penta
 SE-405 08 Göteborg, Sweden
www.volvopenta.com