

COMPLIMENTARY COPY

Not for Sale

Please Insert in your
Westerbeke Service Manual

OPERATOR'S MANUAL

WESTERBEKE 40NA

**MARINE DIESEL
ENGINE**

Publication # 37169

Edition One

February 1988



SAFETY PRECAUTIONS

The following symbols appear in this manual to call attention to and emphasize conditions potentially dangerous to the operator.

WARNING

The above symbol is used in the manual to warn of possible serious personal injury or loss of life.

CAUTION

The above symbol is used in the manual to caution personnel of possible damage to equipment.

Read the manual carefully and thoroughly before attempting to operate the equipment. Know when dangerous conditions can exist and take necessary precautions to protect personnel and equipment.

Fuels, exhaust gases, batteries, electrical equipment, and moving and hot parts are potential hazards that could result in serious personal injury or death. Follow recommended procedures carefully.

Always operate bilge blowers for at least five minutes before starting a gasoline-fueled engine; ensure no gasoline fumes are present before starting.

● Prevent Electric Shock

Shut off electric power before accessing electrical equipment.

Use insulated mats whenever working on electrical equipment.

Make sure your clothing is dry, not damp (particularly shoes), and keep your skin surfaces dry when handling electrical equipment.

Remove wristwatch and jewelry when working on electrical equipment.

Do not connect utility shore power to vessel's AC circuits, except through a ship-to-shore double-throw transfer switch. Damage to vessel's AC generator may result if this is not done.

Be extremely careful when working on electrical components. High voltage can cause injury or death.

● Exhaust Gases Are Toxic

Ensure that the exhaust system is adequate to expel gases discharged from the engine. Check exhaust system regularly for leaks and make sure the exhaust manifolds are securely attached and no warping exists.

Be sure the unit and its surroundings are well-ventilated.

● Use Extreme Care When Handling Engine Fuel (A constant danger of explosion or fire exists)

Do not fill fuel tank(s) while the engine is running.

Do not smoke or use an open flame near the engine or the fuel tank.

● Do Not Alter or Modify the Fuel System

Be sure all fuel supplies have a positive shut-off valve.

Be certain fuel line fittings are adequately tightened and free of leaks.

Make sure a fire extinguisher is installed nearby and is properly maintained. Be familiar with its proper use. Extinguishers rated ABC by the NFPA are appropriate for all applications encountered in this environment.

● Use Extreme Care When Servicing Batteries

Wear rubber gloves, a rubber apron, and eye protection when servicing batteries.

Lead acid batteries emit hydrogen, a highly-explosive gas, which can be ignited by electrical arcing or by a lighted cigarette, cigar, or pipe. Do not smoke or allow an open flame near the battery being serviced. Shut off all electrical equipment in the vicinity to prevent electrical arcing during servicing.

● Avoid Moving Parts

Do not service the unit while the unit is running; if a situation arises in which it is absolutely necessary to make operating adjustments, use extreme care to avoid moving parts and hot exhaust system components.

Do not wear loose clothing or jewelry when servicing equipment; avoid wearing loose jackets, shirts or sleeves, rings, necklaces, or bracelets that might be caught in moving parts.

Make sure all attaching hardware is properly tightened. Keep protective shields and guards in their respective place at all times.

Do not check fluid levels or the drive-belt's tension while the unit is operating.

Do not work on the equipment when mentally or physically incapacitated by fatigue.

IMPORTANT

PRODUCT SOFTWARE DISCLAIMER

Product software of all kinds, such as brochures, drawings, technical data, operator's and workshop manuals, parts lists and parts price lists (and other related information), instructions and specifications provided from sources other than Westerbeke, is not within Westerbeke's control and, accordingly, is provided to Westerbeke customers only as a courtesy and service. WESTERBEKE CANNOT BE RESPONSIBLE FOR THE CONTENT OF SUCH SOFTWARE, MAKES NO WARRANTIES OR REPRESENTATIONS WITH RESPECT THERETO, INCLUDING THE ACCURACY, TIMELINESS OR COMPLETENESS THEREOF, AND WILL IN NO EVENT BE LIABLE FOR ANY TYPE OF DAMAGES OR INJURY INCURRED IN CONNECTION WITH, OR ARISING OUT OF, THE FURNISHING OR USE OF SUCH SOFTWARE.

For example, components and subassemblies incorporated into Westerbeke's products and supplied by others (such as engine blocks, fuel systems and components, transmissions, electrical components, pumps and other products) are generally supported by their manufacturers with their own software, and Westerbeke must depend on such software for the design of Westerbeke's own product software. Such software, however, may be outdated and no longer accurate. Routine changes made by Westerbeke's suppliers, of which Westerbeke rarely has notice in advance, are frequently not reflected in the supplier's software until after such changes take place.

Westerbeke customers should also keep in mind the time span between printings of Westerbeke product software, and the unavoidable existence of earlier, non-current Westerbeke software editions in the field. Additionally, most Westerbeke products include customer-requested special features that frequently do not include complete documentation.

In summation, product software provided with Westerbeke products, whether from Westerbeke or other suppliers, must not and cannot be relied upon exclusively as the definitive authority on the respective product. It not only makes good sense, but is imperative that appropriate representatives of Westerbeke or the supplier in question be consulted to determine the accuracy and currency of the product software being consulted by the customer.

INSTALLATION CHECKS

General

Because the crafts in which Westerbeke engines are installed vary in design, installation procedures will vary according to your craft's specific design. It is not the intent of this section to advise boatyards or installers on procedures already well-developed and well-understood. However, it is important that the owner/operator realize there are details of the installation which require periodic checks to ensure the best operating conditions for the equipment and safe operating conditions for the personnel on board. Proper location and installation of the diesel engine in the vessel are of prime importance.

Factors in the installation that must be considered are ventilation, to aid in cooling and to provide air for engine combustion; exhaust system, to properly discharge raw cooling water, quiet the exhaust and expel exhaust gas; cooling water supply; fuel supply; and electrical connections.

CAUTION

For safety reasons, the engine and transmission are **NOT** filled with lubricating oil for shipment. Before leaving the factory, however, each engine with transmission is thoroughly tested with oil in it. This testing, among other things, provides all internal parts with a coating of oil. This oil acts as a preservative, providing reliable protection against corrosion for at least one year if the engine and transmission are properly stored.

Location

The location should be such that it is *dry*, and in an area where bilge water or water from above cannot splash on the engine. The engine should be properly ventilated and accessible for minor servicing and repairs (access for major repairs should be given consideration as well). The location must be properly ventilated to provide fresh air for engine combustion. The engine's lubrication oil sump dipstick, the fresh water and oil fills, and the transmission's dipstick and transmission or oil fill port must be accessible.

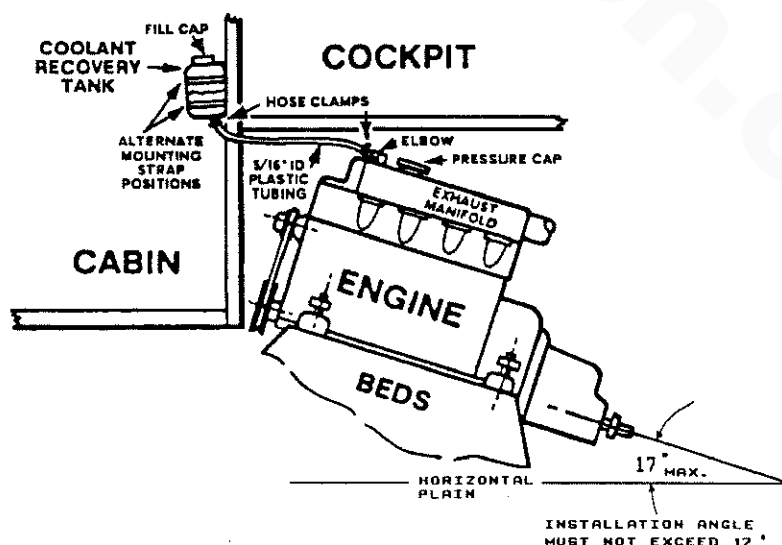

Please note that the engine's installation angle cannot exceed 17° from the horizontal plain.

Rigging and Lifting

The engine is fitted with lifting eyes. Rope or chain slings capable of supporting the engine's weight should be attached to the eyes and the engine lifted by means of tackle attached to these slings. The lifting eyes have been designed to carry the full weight of the engine; therefore, auxiliary slings are not required or desired.

CAUTION

Slings must not be so short as to place significant shear stress on the engine's lifting eyes. Strain placed on the engine's lifting eyes by the lifting sling must not be in excess of 10° from the vertical plain.

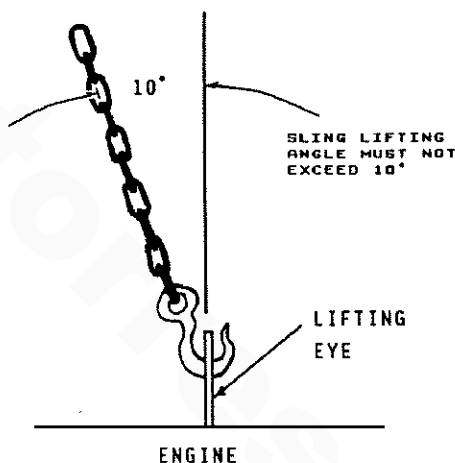

The general rule in moving engines is to see that all of the equipment used is amply strong and firmly fixed in place. Move the engine a little at a time and see that it is firmly supported. Eliminate the possibility of accidents by avoiding haste. Do not lift the engine by its propeller coupling, or pry against this coupling with a crowbar, because excessive pressure of this type may distort the coupling.

In certain situations it may be necessary to lift the engine in positions other than the horizontal position. Certain situations exist by which the engine must be lowered endwise through a small hatchway which cannot be made larger. Under these conditions, if the opening of the hatchway is extremely narrow, it is possible to reduce, to some extent, the outside dimensions of the engine by removing external components such as the alternator, the cooling system's piping, the heat exchanger, certain filters, the mounting lugs and other obstructive equipment. This accessory equipment should be removed by a competent mechanic and special care should be taken to avoid damaging any exposed parts. In addition, be careful not to allow dirt from entering any opening created by the removal of equipment. Parts removed should be returned to their respective position as soon as the engine has cleared the hatchway.

In case it becomes necessary to hoist the engine either front-end upwards or transmission-end upwards, the attachment of slings must be done carefully to avoid the possibility of damaging the parts on which the weight may bear. Special rigging work is best done by someone experienced and competent in handling heavy machinery.

Engine Bolts

Bronze or stainless steel hanger bolts of appropriate size are recommended for use through the engine's flexible mounts. Less preferred are lag screws because their hold on the wood is weakened every time they are moved, whereas the hanger bolts stay in position. If the nut on top of the hanger bolt is removed to allow the engine to be lifted from its resting place, the hanger bolt itself remains in place as a stud. Consequently, the bond between the hanger bolt and the wood is not weakened by the removal of the nut or the engine.

Foundation for the Engine

A good engine bed contributes much toward the satisfactory operation of the engine. The engine's bed must be rigidly constructed and neither deflect nor twist when it is subjected to the engine's weight or to the pressures that the boat may experience while operating in rough seas. The bed must keep the engine's alignment within one or two thousandths of an inch of this position at all times. The bed has to withstand the forward push of the propeller shaft which pushes against the thrust washer bearing which finally pushes against the engine's bolts and bed.

In fiberglass hulls, we recommend that similar wooden stringers as in wooden hulls be formed, fitted, and then glassed securely to the hull. This allows the hanger bolts to be installed firmly in the wood, thereby reducing noise and transmitted vibration.

The engine support stringers must be as wide or wider than the engine mounting isolator. Isolator overhang and/or rounded stringer surfaces are detrimental to the isolators' ability to retain vibration.

Preformed fiberglass engine beds, when used, should be of sufficient thickness to properly support the engine and should be well-glassed to the hull when installed.

The temptation to install the engine on a pair of fiberglass angle irons must be resisted. Such construction will allow engine vibration to pass through to the hull. Flexible mounts require a firm foundation against which they must act if they are to perform their function. When possible, follow bed design A and avoid bed design B (refer to the illustration).

Supports between the bed stringers, and extending from the stringers to the hull, may be required for proper support and to aid in the absorption of vibrations.

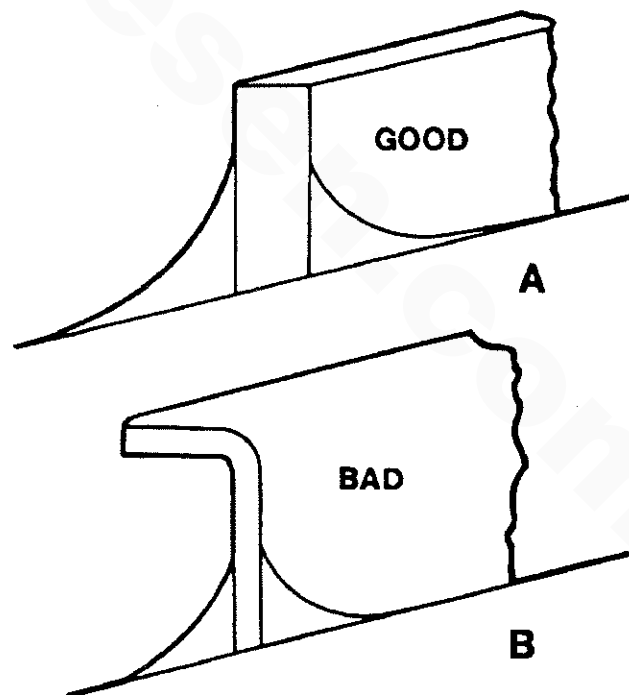

Note: Avoid excessive height, use solid stringer construction (A).

Propeller Shaft Coupling

The propeller shaft coupling fitted to the transmission's output flange must transmit not only the power of the engine to turn the propeller shaft and propeller, but must also transmit the thrust of the engine/transmission either ahead or astern.

The coupling bore should be carefully machined for a slight forced fit onto the shaft and an accurate mating surface for the coupling to the output flange of the transmission.

The W 40NA engine is equipped with a Federal Flexible Coupling. The Federal Flexible Coupling consists of a metal hub and a flange. The hub is accurately bored to accept the rubber bushings, and the face of the flange is machined to match the engine's coupling. The neoprene rubber bushings have a bonded inner brass sleeve and the entire bushing is pressed into the flange using the correct compression pressure. Alloy steel spider pins screw through the bushings into the hub which are locked into position. The rubber bushings are ample to absorb vibration from the propeller and to allow a slight angular misalignment. The Flexible Coupling is not designed to do the work of a universal joint. The engine must be properly aligned before the Flexible Coupling is installed. After the coupling has been installed, the coupling will compensate for misalignments caused by hull distortion and from engine movement. The Federal Flexible Coupling will absorb both thrust and torsional loads. The pins and rubber bushings are replaceable in case of damage.

When ordering replacement parts, refer to the Parts List at the back of this manual.

Propeller

The type and size of propeller varies with the gear ratio and must be selected to fit the application, based upon boat tests. To utilize the full power of the engine, and to achieve ideal loading conditions, use a propeller which will permit the engine to reach its full rated RPM at full throttle while under a normal load and while it is moving the boat forward through the water.

Alignment of the Engine

The engine must be exactly aligned with the propeller shaft using a solid coupling before installing the Federal Flexible. No matter what material is used to build a boat the material will be found to be flexible to some extent; hence, the boat's hull will change its shape to a greater extent than is usually realized when the boat is launched and operated in the water. Therefore, it becomes extremely important to check the engine's alignment at frequent intervals and to correct any errors when they appear.

Misalignment between the engine and the propeller shaft often creates serious problems which are often blamed on other areas suspected of causing the trouble. Misalignment will cause excessive bearing wear, rapid shaft wear and will, in many cases, reduce the life of the boat's hull by loosening the hull's fastenings. A bent propeller shaft will have the exact effect as those just stated; therefore, a perfectly straight propeller shaft is absolutely necessary. One particularly annoying result of misalignment may be leakage of transmission oil through the transmission's rear oil seal.

Never attempt a final alignment with the boat on land. The boat should be in the water and have had an opportunity to assume its final water form. The best time to perform the propeller shaft/transmission coupling alignment is with the fuel and water tanks about half full and all the usual equipment on board, and after the main mast has been stepped and the final rigging has been accomplished.

Take plenty of time in making this alignment and do not be satisfied with anything less than perfect results.

The alignment is correct when the shaft can be easily slipped backward and forward into the counterbore, and when a feeler gauge indicates that the flanges come together at all points. The alignment between the propeller shaft coupling and the engine's coupling can contain an error no greater than one thousandth of an inch per inch of the coupling diameter. For example, if your propeller shaft coupling is three inches in diameter, the maximum error that can be allowed in the alignment is three thousandths of an inch (.003).

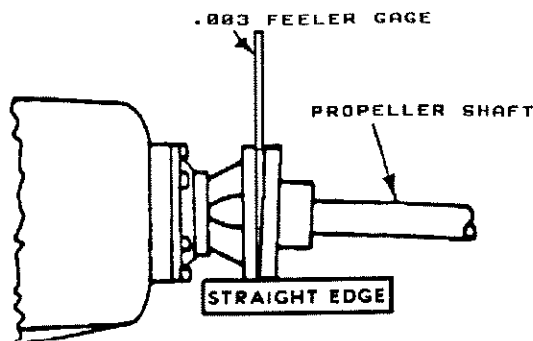

In making the final check for alignment, the engine's half coupling should be held in one position and the alignment with the propeller coupling tested with the propeller coupling in each of four positions (A), while rotated 90° between each position. This test will also check whether the propeller's half-coupling is in exact alignment on its shaft. Then, keeping the propeller coupling in one position, the alignment should be checked by rotating the engine's half-coupling in 90° increments, checking dimension A while in each 90° position until the half-coupling has been rotated full circle.

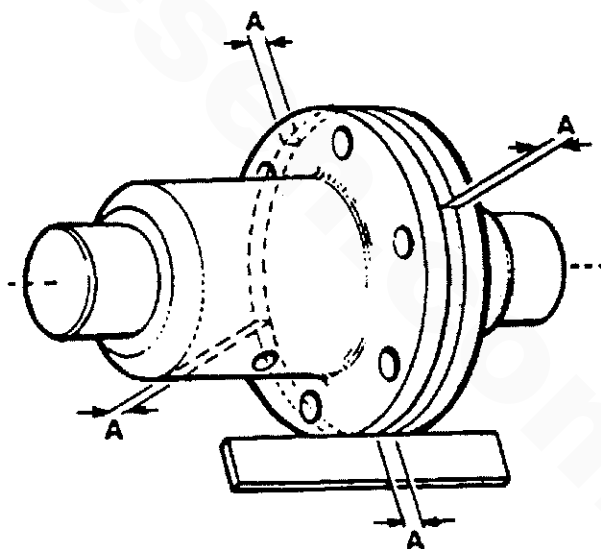

The engine's alignment should be rechecked after the boat has been in service for one to three weeks and, if necessary, perform the alignment again. Usually it will be found that the engine is no longer in alignment. This does not mean that the work has been done improperly at first; rather, it means that the boat has taken some time to take its final shape and that the engine's bed and stringers have probably absorbed some moisture. It may even be necessary to realign the coupling halves again at a later time.

Exhaust System

The exhaust system provides an outlet line to vent engine exhaust gases out of and away from the vessel. The system also discharges sea water which has passed through the engine's sea water circuit by mixing it with hot exhaust gases. This mixing helps cool the exhaust gases and exhaust elbow and plumbing. The exhaust system and the sea water supply to the exhaust *must* be configured to prevent the siphoning of sea water into the exhaust through the sea water cooling circuit and to prevent the entry of sea water into the exhaust through the circuit's through-hull discharge port. If not prevented, sea water entering through the discharge port can fill the exhaust system muffler and enter the engine's cylinders. This will prevent proper starting and possibly cause damage to internal engine components.

The sea water supply hose to the exhaust system water injection elbow should be routed (looped) at least 12 inches above the vessel water line. An anti-siphon break should be installed, when needed, at the top of this loop. The top of the loop should be placed high enough above the vessel's water line so as to remain above the water line when the vessel is underway, no matter what the angle of heel or roll may be.

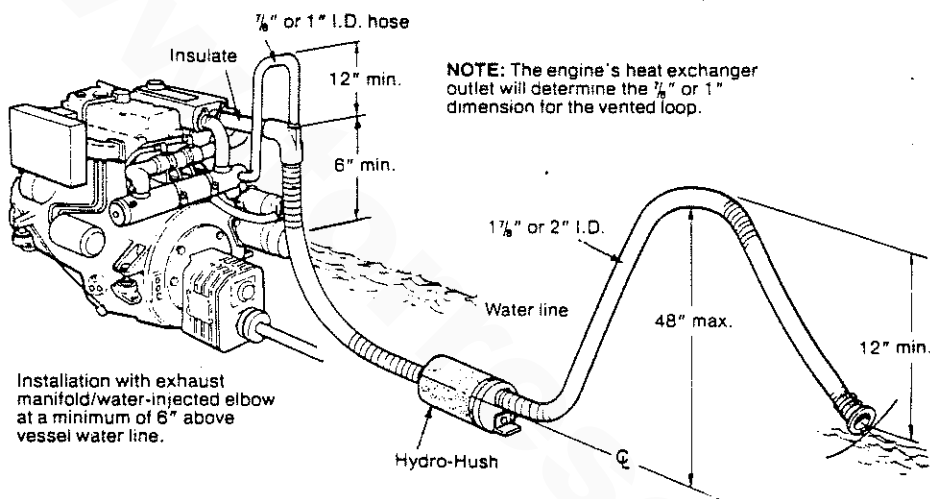

Installation with exhaust manifold/water-injected elbow at a minimum of 6" above vessel water line.

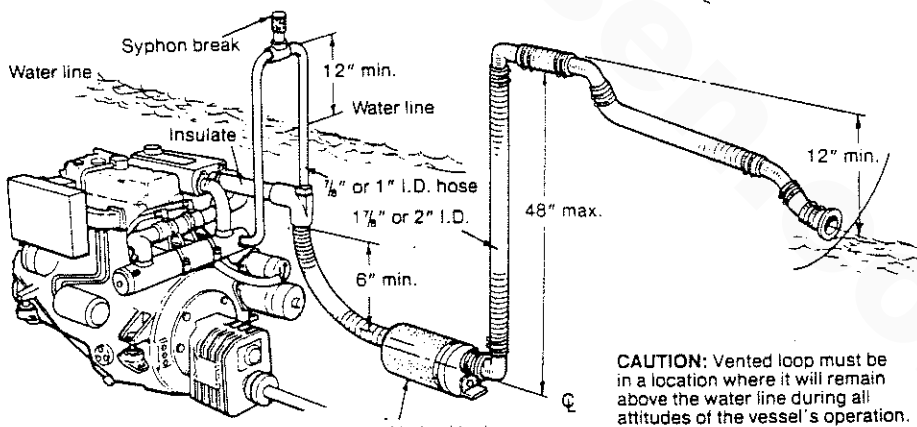

Installation with exhaust manifold/water-injected elbow at or below vessel water line.

CAUTION: Vented loop must be in a location where it will remain above the water line during all attitudes of the vessel's operation.

The sea water supply through-hull sea cock fittings *must* be of the flush-hull type. High-speed scoop type of fittings should not be used as they tend to encourage siphoning.

The exhaust discharge from the water lift muffler should be routed well above the water line then downward to the through-hull discharge. This routing will prevent sea water entry if the through-hull discharge fitting becomes submerged when the vessel heels or rolls while underway, or is subjected to following sea conditions. Refer to the figures shown above for recommended exhaust system installations.

Exhaust Back-Pressure

The exhaust discharge hose must be of adequate size and minimal run to prevent excessive exhaust back-pressure. Exhaust back-pressure should be checked before the engine is put into service. (Refer to the illustration.) Excessive back-pressure will affect the engine's performance.

To measure for back-pressure, use a mercury manometer, a pressure gauge, or a water column. A boatyard or marine mechanic should have a manometer or a pressure gauge.

Measure back-pressure at the exhaust elbow when the engine is running at 3000 rpm. Back-pressure, as measured by a manometer, a pressure gauge, or water column, should not be over the following specifications:

NOTE: Other pressure gauges may be available to test for exhaust back-pressure. Check with a competent mechanic.

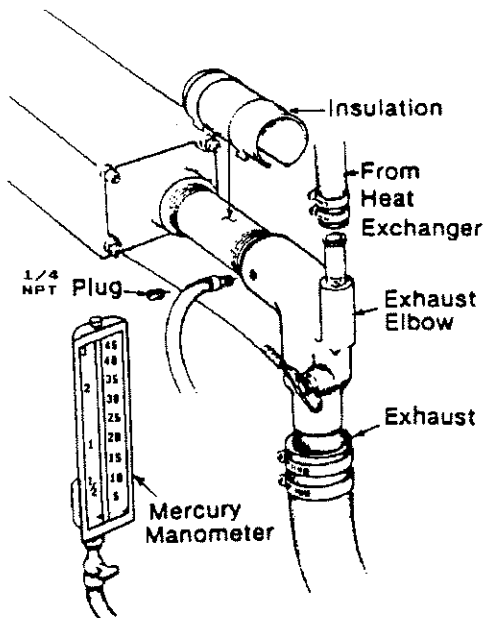

Refer to the pressure specifications below.

A water column can be made by taking a clear plastic tube and taping one end of the tube along a yardstick and fitting the other end of the tube with a 1/4 inch NPT (National Pipe Tap) pipe fitting.

Measure back-pressure at the exhaust elbow when the engine is running at 3600 rpm.

Dimension **A** cannot exceed 39 inches of water.

Back pressure, as measured by a gauge instrument, should not exceed the following specifications:

- 3 inches of mercury (0.104 kg/cm²)
- 39 inches of water in a water column
(.099 kg/cm² at 4° C)
- 22 ounces psi
- 1 1/2 psi

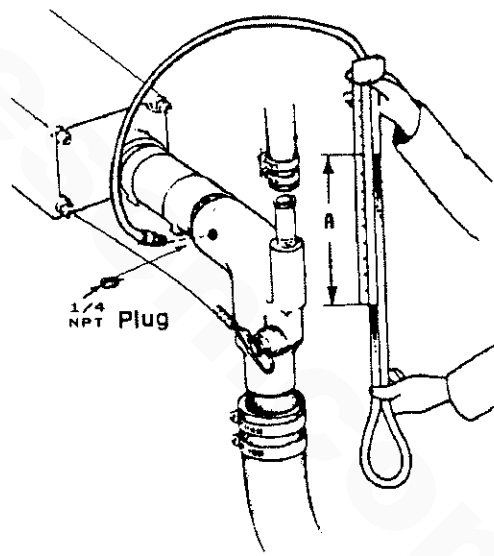

Excessive back-pressure can be caused by a small diameter exhaust hose, a small muffler, sharp bends in the exhaust hose, improper fittings, water pockets, and a high volume of water in the exhaust system due to the length of the exhaust discharge hose. The use of elbows and fittings in the exhaust discharge hose's routing should be limited since these will create flow restrictions and contribute to exhaust back-pressure. The engine's exhaust system must be separate from any other engine's exhaust system. Dry portions of the exhaust system between the engine's exhaust manifold and the water injected exhaust elbow must be insulated to hold in the heat.

Exhaust System Failures

When the engine's sea water is fed into an exhaust system so that the full stream of this water strikes a surface, erosion takes place. This erosion may cause premature failures. The proper design of either a water jacketed or water injected "wet" exhaust system to prevent this problem requires that the sea water inlet be positioned so that the entering stream of sea water does not directly strike a surface. In addition, the velocity of the entering sea water stream should be as low as possible, which can be achieved by having inlet fittings as big in diameter as possible.

The best protection against exhaust system leaks is to routinely inspect the complete exhaust system. Check for leaks around manifolds, gaskets, and welds. Make sure exhaust lines are not heating surrounding areas excessively. If excessive heat is present, correct the situation immediately. If you notice a change in the sound or appearance of the exhaust system, inspect the exhaust system and correct the cause.

Exhaust risers installed off the exhaust manifold should not exceed **8 lbs** in total weight when rigidly connected. Excessive weight and vibration can result in a manifold failure and/or the fracturing of the riser from the manifold at its attachment. Dry portions of the exhaust connected to the manifold, which lay before the water injected exhaust system, *MUST* be properly insulated to retain the exhaust heat within the exhaust pipe.

WARNING

Although diesel engine exhaust gases are not as toxic as exhaust fumes from gasoline engines, carbon monoxide is present in diesel exhaust fumes in less concentration. Carbon monoxide is a dangerous gas that can cause unconsciousness and is potentially lethal. Some of the symptoms or signs of carbon monoxide inhalation or poisoning are as follows:

- o Dizziness
- o Intense Headache
- o Weakness and Sleepiness
- o Vomiting
- o Muscular Twitching
- o Throbbing in Temples

If you experience any of the above symptoms, get out into fresh air immediately.

Make sure there are no unnecessary objects suspended from any portion of the exhaust lines. Excessive weight could cause deflection or distortion of the lines, resulting in damage or leaks. Inspect insulated portions of the exhaust system to ensure there is no deterioration of the insulation.

Oil Drain Hose

An oil sump drain hose is located at the lower front of the engine. Oil may be drained from this hose by removing the cap and the discharge end of the hose from the support bracket and lowering the hose into a container. The hose cap fitting is 1/4 inch NPT (National Pipe Tap) and can be extended, or have a pump added, for easier removal of the old oil, if desired.

Connecting Pressure Sensing Devices to Oil Galleries

Oil pressure sensing devices, such as senders and switches, must not be connected to an engine's oil gallery with the use of extended nipples or tees. The reason is simply that continued engine vibration causes fatigue of the fittings used to make such a connection. If these fittings fail, the engine loses its oil pressure and quickly seizes.

When additional sensing devices such as switches or sensors need to be installed that function on engine oil pressure, these devices must be bulkhead-mounted and connected to the oil gallery using an appropriate grade of lubricating oil hose. Any fittings used to connect the hose to the gallery must be of steel or malleable iron composition. Brass must not be used for this application.

Automatic Alarm System

High Water Temperature Alarm

A high water temperature alarm buzzer has been supplied with the instrument panel. If the engine's fresh water coolant reaches 210° F (98.8° C), a water temperature switch on the engine closes causing the alarm to emit a *continuous* signal. Refer to the "DESCRIPTION OF INSTRUMENT PANEL" section of this manual for the location of the alarm in your engine panel, page 24.

Low Oil Pressure Alarm

A low oil pressure alarm switch is located off the engine's oil gallery. This switch monitors the engine's oil pressure. Should the engine's oil pressure fall to 10 - 15 psi, the switch will close sounding this same alarm. In this event, the alarm will emit a *pulsating* signal. Refer to the "DESCRIPTION OF INSTRUMENT PANEL" section of this manual for the location of the alarm in your engine panel, page 24.

Cooling System

The engine is fresh water cooled by an engine-mounted heat exchanger. Sea water is used as the heat exchanger's cooling medium. Sea water is pumped into the exchanger by a sea water pump, where it cools the fresh water that circulates through the engine block, and is then injected into the exhaust elbow, carrying with it the heat removed from the engine's fresh water cooling system.

Sea water should be supplied to the sea water pump through a flush-type hull fitting using a wire-reinforced hose between the through-hull fitting and the sea water pump. The sea water should be directed through a visual-type sea water strainer, which will trap debris before it reaches the sea water pump and the heat exchanger, and then be delivered to the pump. Hoses routed from the through-hull fitting to the strainer and to the sea water pump should be wire-reinforced to prevent the hose from collapsing while the engine is running (suction from the pump may collapse a non-reinforced hose). The sea water strainer should be mounted at or below the water line to make sure the sea water line remains primed.

CAUTION

DO NOT use a scoop-type through-hull fitting as a means of supplying sea water to the engine. Water pressure against this type of fitting, while the vessel is under sail, can push sea water past the sea water pump's impeller into the engine's exhaust system, filling it and the engine as well. Flush-type, clear, through-hull fittings are recommended and should be located on the hull so as to be below the waterline during all angles of boat operation.

The use of common-type street elbows is not recommended for plumbing the sea water circuit. These generally have very restrictive inside diameters. Machine fittings are preferred.

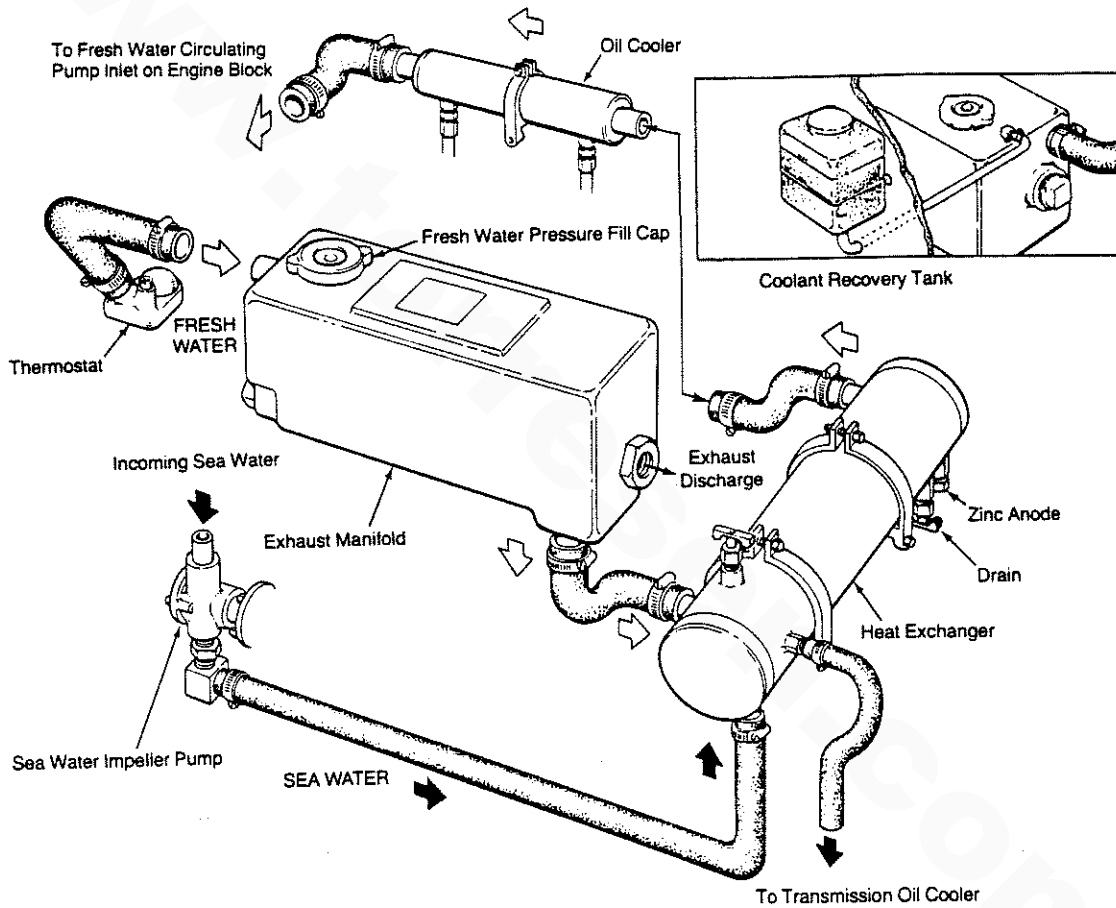

Illustrated above is the cooling system for the W 40NA engine

Sea Water Intake System

Make sure the intake system (sea water cooling system) is in proper order. Check that the through-hull inlet, sea cock and strainer are unobstructed. Sea cocks and strainers should be at least one size greater than the inlet thread of the sea water pump. The strainer should be of the type that may be withdrawn for cleaning while the vessel is at sea and should be mounted below the water line to ensure self-priming. Inspect the sea water lines to ensure there are no collapsed sections, which would restrict water flow. Make sure there are no air leaks at any of the connections. Placing double clamps at the sea water plumbing connection, located below the water line, is strongly recommended.

Fuel System

The fuel system should be installed in such a manner as to allow the engine-mounted mechanical fuel lift pump to maintain a positive inlet pressure to the fuel injection pump under all operating conditions. The minimum size of the fuel supply line and fuel return line is 1/4 inch, inside diameter, and there should be a primary fuel filter installed between the fuel tank and the fuel lift pump. Only one fuel filter is installed on the engine, between the mechanical fuel lift pump and the injection pump; this filter has a replaceable filter element.

The fuel tank's fuel pickup tube should be clear and unobstructed. No screen or gauze strainers should be incorporated in the fuel pickup tube.

Make sure that the fuel supply and return lines are securely anchored to prevent chafing and that all fittings are sufficiently tightened to prevent leaking. Also make sure your fuel system has a positive shut-off valve; know its location and how it operates.

NOTE: DO NOT use spring-loaded check valves in the fuel supply line in lieu of mechanical shut-off valves. This type of valve can create fuel starvation problems for the engine's fuel system.

Fuel tanks that are located below the engine's fuel system level **must** have its fuel return at the tank extending down into the tank in the same manner as a pickup tube, otherwise fuel siphoning out of the engine's fuel system through the return will take place.

Ensure that the fuel tank filler is properly sealed to prevent water entry should it become awash. The fuel tank's vent should be routed so as to prevent water entry as well.

Be sure there is a fire extinguisher installed near the unit and that it is properly maintained. Be familiar with its use. An extinguisher with the NFPA rating of ABC is appropriate for all applications in this environment.

Electrical System

The electrical system should be checked to ensure that all wiring harnesses are tied down properly with clamps or plastic ties, spaced at intervals close enough to prevent chafing from vibration. Check to ensure that all the engine's harness connections are tight and that they are connected to the appropriate terminals.

WARNING

Do not smoke or allow an open flame near batteries. Lead acid batteries emit hydrogen, a highly-explosive gas. Turn off the emergency switch in the positive line of battery.

Make sure the positive (+) battery connection is connected to the battery connection of the starting solenoid. The negative (-) battery connection should be connected to the system ground (the engine block).

WARNING

When servicing the battery or checking the electrolyte level, wear rubber gloves, a rubber apron, and eye protection. Battery acid may splash on the skin or into the eyes inadvertently when removing electrolyte caps.

Check level and specific gravity of battery electrolyte to ensure maximum engine starting efficiency. Make sure terminals are clean and tight.

Ventilation

The ventilation requirements of the engine include the following: combustion air is required for the engine's cylinders and ventilating air is required to clear the bilges below the engine, as well as the compartment in which the engine is located, of engine heat and potentially toxic and flammable diesel fumes. Refer to the "SPECIFICATIONS" section of this manual for airflow requirements, page 8.

PREPARATION FOR STARTING

This section of the manual provides the operator with preparation, initial starting, break-in, starting (cold or warm), and stopping procedures. Follow the procedures as presented, for the conditions indicated, and your Westerbeke engine set will give you reliable performance and long service life.

Fill the engine with oil by pouring engine oil through the oil filler cap. Fill the engine up to or near the upper limit on the dipstick (the installation angle may have an effect on the dipstick reading). Select readily available lubricating oil with an API specification of CC or CD and an SAE number suitable for the temperature in your operating area (see page 47). For the quantity of oil needed in this engine, refer to the "SYSTEM SPECIFICATION" section of this manual, page 8.

Fill the transmission to the **FULL** mark on the dipstick with the correct lubricant. (Refer to the "SYSTEM SPECIFICATIONS" section of this manual, page 9.)

Each unit is supplied with a coolant recovery kit (#24977) as standard equipment, to which the following applies:

- A. Remove the pressure cap from the engine's exhaust manifold and slowly fill the engine's cooling system with a mixture of water and antifreeze suitable for your temperature zone. (See the "COOLING SYSTEM" section of this manual, page 42.) Operate the engine and observe the coolant level in the manifold. Maintain this level to the base of the filler neck. Once the engine reaches its operating temperature (170 - 190° F), ensure that there is coolant flow to the domestic water heaters when installed. Top off the cooling system and install the pressure cap.
- B. Make sure the plastic recovery tank is properly mounted near the unit (with the bracket provided), in a location where it can be monitored and filled easily. The recovery tank should be mounted at manifold level or above. In these installations that require it, the plastic recovery tank can be mounted below the exhaust manifold's level.
- C. Add coolant to the plastic tank after the engine has been started and operating temperature has been reached, to ensure that all air is expelled from the manifold and the engine's cooling system. With the manifold filled and the pressure cap installed, fill the plastic recovery tank half full. Monitor daily and add coolant as needed.

Fill the fuel tank with a good grade of No. 2 diesel fuel and prime the fuel system up to the engine (see page 32). When returning fuel is free of air, the engine's fuel system is bled and the engine is ready to start.

Ensure that the Installation Checks have been made in accordance with those specified in the "INSTALLATION CHECKS" section of this manual (refer to page 10).

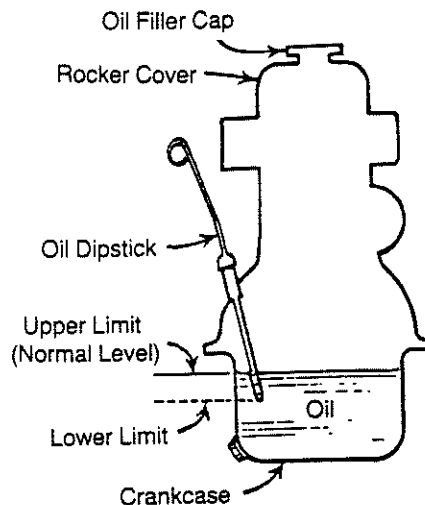

Starting System

The W 40NA diesel engine uses an electric starter for both normal and cold weather starting. A cold start aid system is furnished on the W 40NA engine as standard equipment (part #36258). Both the thermostart device and the cold start aid are located on the air intake, manifold side of the engine. The PREHEAT button energizes the thermostart device assists in vaporizing the fuel at the intake manifold inlet. The vaporized diesel fuel is drawn into the cylinder during cranking and allows for easy combustion during compression. This process allows the engine to start rapidly and reduces wear on the starter.

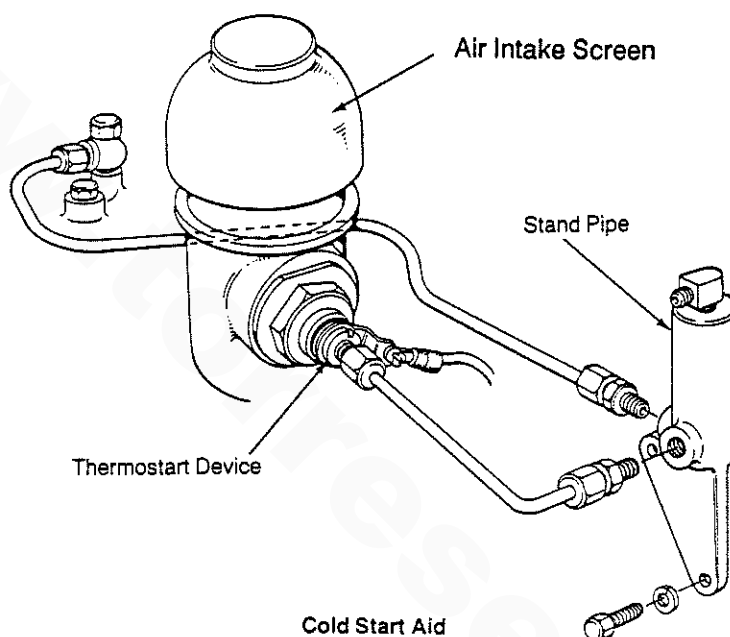

The W 40NA engine's electrical system is designed so that the PREHEAT button must be depressed for the time specified in the "Preheat" chart shown on page 26. While keeping the PREHEAT button depressed, the START button must be pressed to crank the engine.

NOTE: The START button will not crank the engine unless the PREHEAT button is depressed at the same time. When the PREHEAT button is depressed, the thermostart device is activated. USE THE PREHEAT BUTTON ONLY AS NECESSARY. Overuse of the PREHEAT button will overheat the thermostart device.

Refer to the "STARTING PROCEDURE" section of this manual for starting instructions, page 26

STOPPING PROCEDURES

In the cockpit of the boat, there is a tee handle or a knob-type shut-off control. When this control is pulled OUTWARD, the control will STOP the engine. The other end of the shut-off control is attached to a lever on the top of the fuel injection pump. (Pushing the shut-off control fully inward will place the engine in the RES-TART - RUN position.

When the engine is stopped, turn the Circuit Breaker located in the vessel to the OFF position. If the Circuit Breaker is left ON, the battery will discharge.

CAUTION

DO NOT attempt to shutdown the engine by turning the Circuit Breaker OFF. The Circuit Breaker only provides power to the instrument panel and to the DC alternator: the engine will continue running even if the Circuit Breaker is turned OFF. Stop the engine by pulling the shut-off control fully OUTWARD.

Engine Break-In Procedures

Although your engine has experienced a minimum of one hour of test operations to ensure accurate assembly and proper operation of all systems, break-in time is required. The service life of your engine is dependent upon how the engine is operated and serviced during its initial hours of use.

Your new engine requires approximately 50 hours of initial conditioning operation to break in each moving part in order to maximize the performance and service life of the engine. Perform this conditioning carefully, keeping in mind the following:

1. Start the engine according to the "STARTING PROCEDURE" section found on page 26; run the engine at fast idle while checking that all systems (sea water pump, oil pressure, battery charging) are functioning.
2. Allow the engine to warm up (preferably by running at fast idle) until the water temperature gauge moves into the 130-140° F range.
3. While using the vessel under power, vary the engine's rpm cruise settings during the engine's initial 25 hours of operation.
4. Avoid rapid acceleration, especially with a cold engine.
5. Use caution not to overload the engine. The presence of a gray or black exhaust, and the inability of the engine to reach its full rated speed, are signs of an overload (that is, a propeller that is too large).
6. During the next 25 hours, the engine may be operated at varying engine speeds, with short runs at full rated rpm. Avoid idling the engine for prolonged periods of time.

Breaking-in a new engine basically involves seating the piston rings to the cylinder walls. This cannot be accomplished by long periods of running at idle, nor by early running at full speed.

Idle running may glaze the cylinder walls, resulting in excessive oil consumption and smoky operation. Excessive speed or heavy overloading, especially with a cold engine, may cause scoring of the cylinder walls, producing similar results.

As indicated above, operate the engine in moderation during the 50-hour break-in period. (On one hand don't baby the engine, but on the other hand, however, don't abuse it.)

Starting Under Normal Conditions

Follow the procedure below for normal starting of the engine:

1. Check the engine and transmission lubricant levels and fill, if necessary.
2. Make sure there is sufficient fuel on board. Keep fuel tank(s) as full as possible. Check the fuel filters and water separators for the presence of contaminants and/or water. Drain and clean them as needed.
3. Check the coolant level in the plastic recovery tank. Add coolant solution as needed.

NOTE: Excessive loss of coolant from the plastic recovery tank indicates a cooling system leak. Check the entire cooling system and the recovery tank and its connections at the exhaust manifold, and pressurize the system to locate the leak. In cases of excessive coolant loss, the system must be refilled as outlined under the "PREPARATION FOR STARTING" section of this manual, page 22.

4. Check for oil and fuel leaks, particularly if signs of such leaks are found on the bottom of the engine or below the engine.
5. When checking your engine's coolant and oil levels, check the engine for any noticeable abnormalities such as loose or missing bolts, loose brackets and mounts, loose hose clamps, chafed wires, or any other components that exhibit wear or are loose.

Start the engine in accordance with the "STARTING PROCEDURE" instructions found on page 26, and allow the engine's operating temperature to reach 140 - 150° F before operating the engine underway.

Starting Under Cold Conditions

Under extremely cold temperatures, the following conditions can occur. Follow the instructions listed below when operating your engine in cold weather.

LUBRICATING OIL TURNS VISCOUS - Make certain that the lubricating oil used conforms with the ratings for the prevailing atmospheric temperature. Refer to the "LUBRICATION SYSTEM" section of this manual, page 47 for an atmospheric/oil viscosity specification table.

VOLTAGE ACROSS THE BATTERY TERMINALS DROPS - Make certain that the battery is fully charged to minimize voltage drop across the battery terminals.

THE TEMPERATURE OF THE INTAKE AIR IS LOW AND THE COMPRESSION TEMPERATURE DOES NOT RISE ENOUGH - Allow the thermostart device to operate sufficiently to aid in starting during the preheat period whenever the temperature of the intake air is low and when the compression temperature within the cylinders will not rise quickly during cranking. Refer to the "Preheat" chart found in the "STARTING PROCEDURE" section of this manual, page 26.

FUEL SYSTEM

Diesel Fuel

Use No. 2 diesel fuel with a cetane rating of 45 or higher. Never use kerosene or home heating oil since these fuels do not have the same lubricating properties as No. 2 diesel fuel.

In cold weather particularly, water vapor is produced by condensation when air is present in the fuel tank. Keep fuel tank(s) full and completely free of dirt and water.

Fuel Filters

A primary fuel filter of the water entrapment type must be installed between the fuel tank and the engine. A primary fuel filter, shown here, is available from your local Westerbeke representative or your boatbuilder. This filter, adapted for boatbuilder use, comes complete with fittings for either hose or metal tubing. Mount it in an accessible place, inspect it often and drain off water accumulation frequently.

If a water trap type filter is not installed between the fuel tank and the engine-mounted fuel system, any water in the fuel system will tend to lay in the bottom of the electric lift pump. Internal metal parts of the lift pump will rust. Particles will pass on to filters and eventually to the injection pump and injectors with damaging results and the possibility of expensive repairs. Remember, water damage to the fuel system is not covered under the Westerbeke warranty.

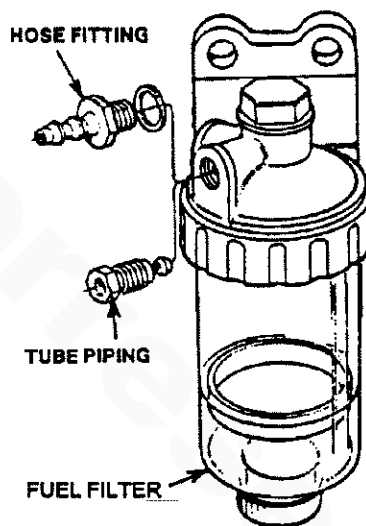

INSTALLATION INSTRUCTIONS

1. BOLT SEDIMENT/WATER TRAP SECURELY TO AN ACCESSIBLE STRUCTURE SO POSITIONED THAT A RECEPTACLE TO CATCH DRAINAGE CAN BE PLACED UNDER IT.
2. IF FUEL IS TO BE PIPED WITH COPPER, OR BRASS TUBING, USE NUTS AND FERRULES PROVIDED. BE SURE THE TUBING PROJECTS 1/4 INCH THROUGH THE FERRULE BEFORE TIGHTENING THE NUT.
3. IF FUEL IS TO BE PIPED WITH HOSE, USE THE TWO BRASS BARBED FITTINGS AND WASHERS SUPPLIED. BE CERTAIN THAT THE HOSE SELECTED HAS DIAGONAL BRAID INSERTED (TO CLING ON THE BARB), THAT IT IS NEOPRENE LINED, AND THAT IT IS USCG APPROVED.
4. IF WATER IS PRESENT IN THE FUEL, IT WILL COLLECT SLOWLY IN THE BOTTOM OF THE SEDIMENTER. WHEN THE RED FLOAT RING REACHES THE DRAIN LINE ON THE PLASTIC BOWL, LOOSEN THE BOTTOM DRAIN PLUG UNTIL ALL WATER RUNS OUT.
5. TIGHTEN DRAIN PLUG SECURELY SO NO AIR CAN ENTER THE SYSTEM.
6. ENERGIZE THE FUEL PUMP TO REFILL THE BOWL.

In addition, any gasoline in the fuel system will damage the engine's fuel injection pump assembly and injectors, as gasoline does not have the same lubricating qualities as diesel fuel.

Although most boatbuilders supply a water trap/filter, some do not. Westerbeke offers a sedimentary/water trap/filter as an optional extra at moderate cost. The filter is supplied with fittings for either hose or metal tubing fuel lines.

Priming and Bleeding the Fuel System

The W 40NA engine has only one replaceable fuel filter located on the engine-mounted fuel system. This fuel filter is located just after the discharge side of the mechanical fuel lift pump (just below the fuel filter). The manual-bleeding design of the fuel system allows the fuel filter to be easily serviced. To replace the fuel filter, remove and replace filter elements as described in the "Replacing Filter Elements", section of this manual, page 35. *Be careful to catch any fuel that may spill from within this fuel filter assembly.*

NOTE: Any primary fuel filter/water separator installed between the fuel tank and the engine's fuel lift pump (that is, a Raycor, Dahl or other similar filters) should be manually filled before an attempt to bleed the fuel system between the fuel tank and the engine is made.

To bleed remaining air from that portion of the fuel system which runs between the fuel tank and the engine, once the primary fuel filter has been manually filled, move the mechanical fuel lift pump's priming lever up and down using steady, even strokes (one stroke per second) for a period of one minute. For this priming operation, no fittings should be open. Refer to the illustration of the fuel system when following the procedure described above, page 33.

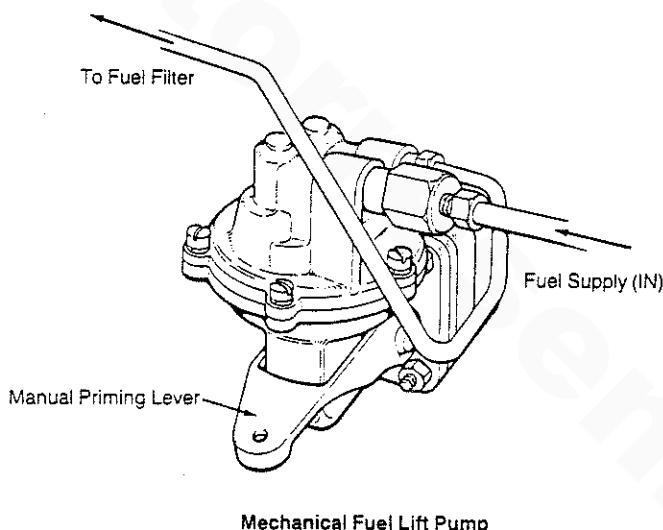

Refer to the illustration on the next page when following the procedures described below.

1. After all air has been bled from between the fuel tank and the engine, proceed to either one of the two bleed points (#1) located on top of the fuel filter (see the next page). Choose the one that is easily assessable. Loosen the banjo bolt on top of the filter or the plug, on the side of the filter housing, one to two turns. **DO NOT** remove the bolt or the plug.
2. Move the priming lever up and down (as described on the previous page) to purge the air out of the secondary fuel filter through the open banjo bolt or plug.

NOTE: As a safety precaution, place a small plastic trash bag containing a few cloth rags around and under the secondary filter to catch any fuel that may spill from within the filter when it is removed.

Also note that when working the manual priming lever on the fuel lift pump, move the lever up and down using long, even strokes. **DO NOT** operate the lever using rapid jerks.

In some rare instances, the fuel lift pump may be at or near its internal maximum pump stroke. In this situation, no pumping action will be accomplished using the external manual priming lever. In this case, turn the engine over one or two turns (do not attempt to start the engine) to reposition the pump's internal pumping lever. Now attempt to bleed the fuel system using the manual priming lever.

Once the fuel system is bled, which is indicated by a flow of bubble-free fuel from bleed point # 1, retighten either the banjo bolt or the plug and proceed to point # 2.

3. Using either a 5/16" box wrench or a 1/4" drive 5/16" socket wrench, open the 5/16" # 2 bleed screw, located on the side of the fuel injection pump, one-half to one turn only. **DO NOT** remove this special bleed screw. Once again move the manual priming lever up and down to purge all of the air from this area of the fuel injection pump. When the fuel flows bubble-free from the #2 bleed screw, retighten the bleed screw and proceed to point # 3. Refer to the illustration below.

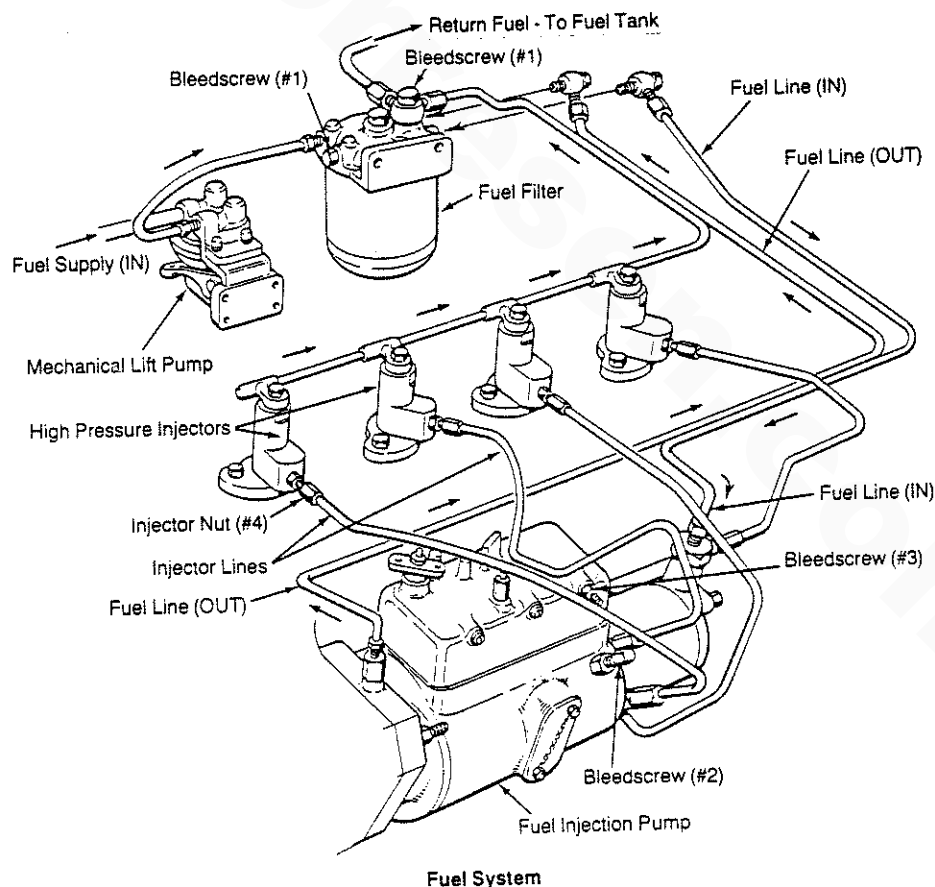

4. Using the 5/16" box wrench or the 1/4" drive 5/16" socket wrench, open the #3 bleed screw and bleed this portion of the fuel injection pump in the same manner as described in step #3. Proceed to step #5

NOTE: Make sure that the throttle is fully open and the engine's shut-off lever is in its RUN position before proceeding to step #5.

5. Using a 5/8" open end wrench, loosen all four high pressure injector line nuts (#4), located at the base of each injector, one to two turns. Using the starter motor, crank the engine over to bleed any air in the high pressure lines between the fuel injection pump and the injectors. Crank the engine until fuel spurts from between the injector nut and the high pressure injector line.

NOTE: Only spurts of fuel should come from this bleed point, not a steady flow of fuel.

DO NOT crank the engine for long periods of time. Excessive cranking will cause the starter to overheat and will flood the exhaust system with sea water.

Retighten all four high pressure injector line nuts with the 5/8" open end wrench.

NOTE: Excessive torque is not required to properly tighten the injector line nuts to the base of the high pressure injectors.

6. The engine is now primed and ready to start. Leaving the throttle in the FULL OPEN position, make sure that the engine's STOP lever is in the RUN position and that the transmission is in NEUTRAL. At this point, proceed to start the engine. Use the PREHEAT button as required and crank the engine using the starter. Once the engine fires, return then throttle to its IDLE position. Check to make sure that the engine's instruments indicate the proper oil pressure reading and that sea water is discharged with the exhaust. Allow the engine to idle between 1000 to 1200 rpm for five minutes to make sure that all air in the fuel system has been bled.

If the engine fails to start, re-prime the fuel system and try to start the engine once again.

CAUTION

Prolonged cranking intervals without the engine starting can result in filling the engine-mounted exhaust system with sea water coolant. This may happen because the sea water pump is pumping sea water through the sea water cooling system during cranking. This sea water can enter the engine's cylinders by way of the exhaust manifold once the exhaust system fills. Prevent this from happening by closing the sea water supply through-hull shut-off, drain the exhaust muffler, and correct the cause for the excessive engine cranking needed to obtain a start. Engine damage resulting from this type of sea water entry is not a warrantable issue; the owner/operator should keep this in mind.

NOTE: When the secondary, on-engine fuel filter has been serviced, the #1 and #2 bleed points should only be bled to make sure that all air has been removed from the fuel system. No other bleed points need to be opened at this time.

Owners/operators may find daubing white paint on each of the bleed points helpful. If an unexpected problem occurs in which the fuel system needs bleeding, these points will be clearly visible.

While the likelihood of having to service the fuel system at sea is small, the possibility does exist. Therefore, we recommend that a replacement fuel filter be carried on board at all times. Each fuel filter comes with two O-ring gaskets. Select the part numbers for this fuel filter from your Parts List and purchase spares from your local Westerbeke Dealer or Distributor.

If a leak should develop at a banjo or sealing washer that cannot be corrected by a simple tightening of the fitting, replace the leaking washer. A Fuel Hardware Kit is available for this engine which contains all the sealing washers used in the fuel system, except those noted in the fuel filter replacement cartridge illustration shown below.

Replacing the Fuel Filter Elements

After the first 50 hours of operation, remove filter cup # 9 by unscrewing bolt #3 and drawing down on the #6 element. *Be careful to catch any fuel that may spill from within this fuel filter cup.* Discard the old # 6 filter element and the old # 5, #7 and #8 O-rings. Clean the #9 filter cup and install the new #6 filter element along with new # 5, #7 and #8 O-rings.

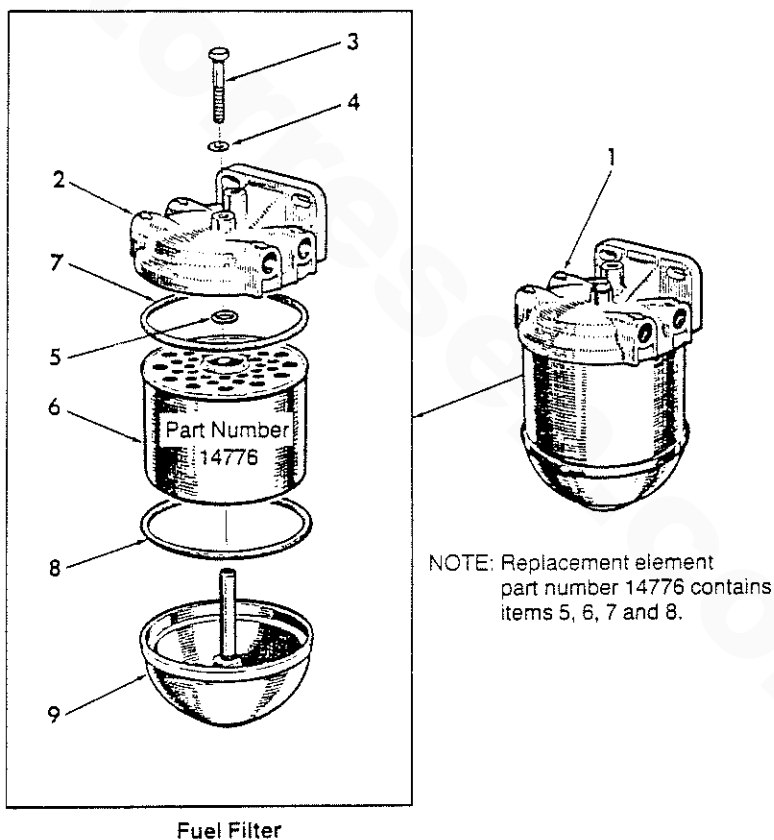

After the first 50-hour change, the change period may be increased to 200 hours or once per season.

Fuel Injection Pump

The fuel injection pump is one of the most important components of the diesel engine and, therefore, calls for the utmost caution in handling. Furthermore, the fuel injection pump has been thoroughly bench-tested and should not be tampered with.

Idle speed and timing adjustment are the only adjustments the servicing dealer can perform on the injection pump. Other types of adjustments or repairs must be performed by a qualified injection service shop.

To obtain long and satisfactory service from the injection pump, always use fuel which is free from impurities and maintain a good filtration and water separation system between the fuel tank and the engine. Service this system regularly: the injection pump it saves may be your own.

Belt Drive System

The illustration below shows the complete belt drive system for the W 40NA engine. A compressor bracket and mounting bracket are provided for the installation of a Grunnert refrigeration compressor.

Two alternators are mounted on the W 40NA engine. The second alternator charges the ship's service battery(s). Two oil pressure cut-out switches for the fields on the alternators are mounted on a bracket at the rear of the engine. These switches will prevent any load on the engine upon the engine's initial start-up.

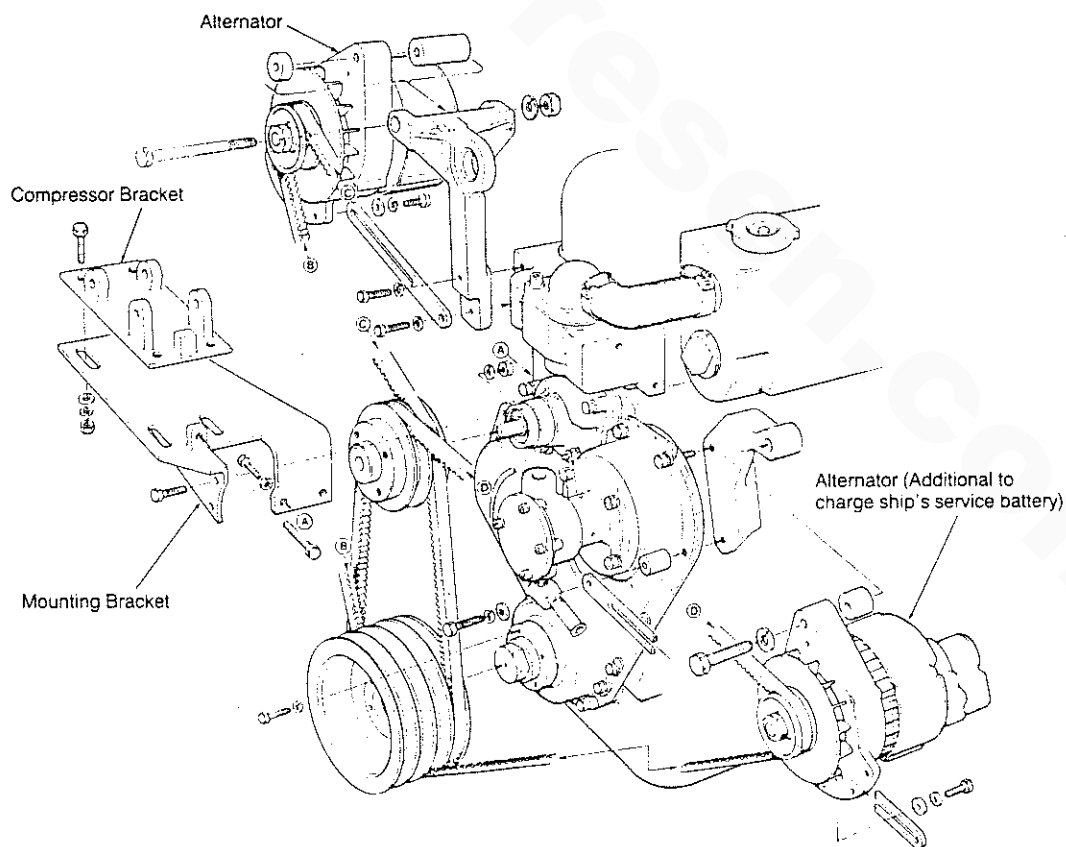

ELECTRICAL SYSTEM

Engine 12-Volt DC Control Circuit

The Westerbeke 40NA propulsion engine has a 12-Volt DC electrical control circuit, as shown on the wiring diagrams which follow on pages 40 and 41. Refer to these diagrams when troubleshooting or servicing electrical components on the engine.

CAUTION

To avoid damage to the battery charging circuit, *never* shut off the engine battery switch while the engine is running.

When the engine is not running, shut OFF the engine's battery switch to avoid electrical shorts when working on the engine electrical circuit.

Note that the engine's control system (electrical System) is protected by a 20-Ampere manual reset circuit breaker located on the rear lifting bracket.

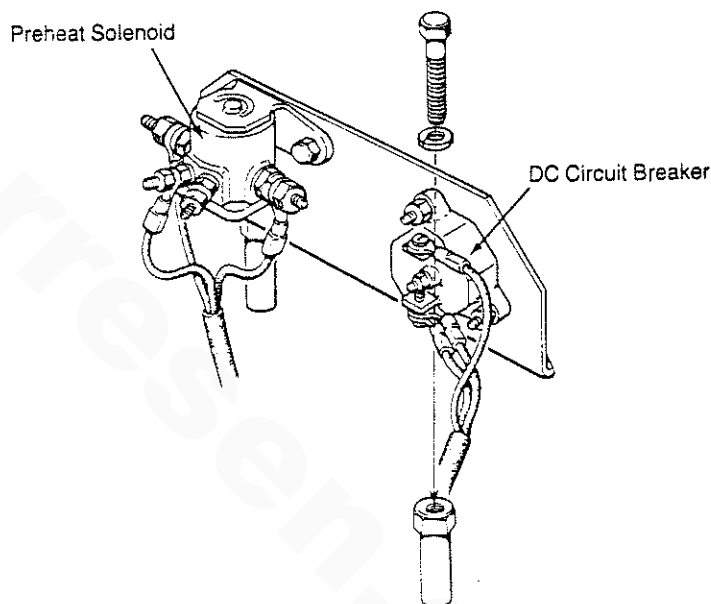

Battery Specification

The minimum recommended capacity of the battery used in the engine's 12-Volt DC control circuit is 125 - 150 Ampere-hours (minimum).

CAUTION

When quick-charging the battery with an external charger, be sure to disconnect the battery cables from the battery. Leaving the charging circuit connected while quick-charging will damage the alternator's diodes.

Alternator

CAUTION

When testing the alternator circuit (charging circuit), do not use a high-voltage tester such as a megger; damaged diodes could result.

During high-speed operation of the engine, do not disconnect the positive terminal of the battery from the **B** terminal of the alternator, nor disconnect the negative terminal of the battery from the ground. Damage to the alternator's diodes will result.

When cleaning the engine with a steam cleaner, be careful to keep steam away from the alternator.

Always connect the battery's cables to the correct terminals. Reversing the connections will damage the DC charging alternator. To connect the battery, connect the (+) Positive lead (Hot) first and then connect the (-) Negative lead (Ground) last. To disconnect the battery, disconnect the (-) Negative lead (Ground) first, and then disconnect the (+) Positive lead (Hot) last.

Refer to pages 40 and 41 for the electrical system wiring schematic for the W 40NA.

The charging system consists of two alternators with external voltage regulators, an engine-mounted circuit breaker, a battery and connecting wires.

Because of the use of IC's (integrated circuits), the electronic voltage regulator is very compact and is mounted on the rear bracket of the alternator.

Charging Voltage Test

If you suspect that the alternator is not producing enough voltage to charge the engine's battery, perform the following voltage test.

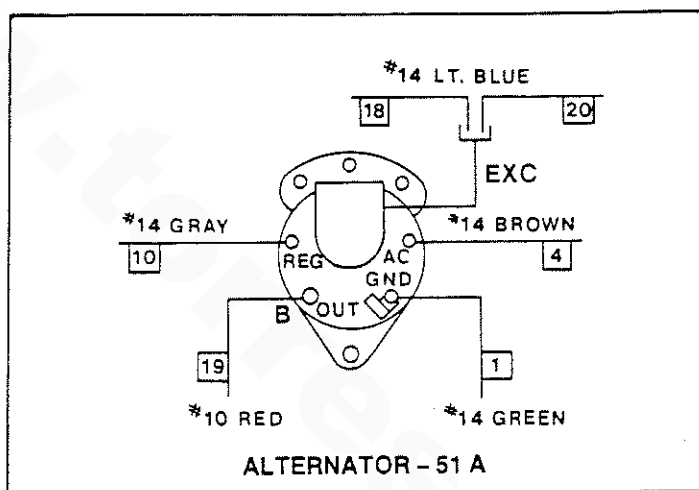

Interconnections for Charging Voltage Test

1. Using a volt/Ohms meter make sure that 12 Volts are at the **EXC** connection while the engine is running and the oil pressure **EXC** switches are closed.
2. Using a voltmeter, connect the voltmeter's red wire clip to the **B** output terminal on the alternator. Refer to the schematic shown above.
3. Connect the other wire clip to a ground on the engine.
4. Start the engine and increase the engine's speed to 2000 rpm. Now record the reading given by the voltmeter.

The voltage reading for a properly operating alternator should be between 13.5 to 14.5 volts. If your alternator is over or under charging, have it replaced or rebuilt by a reliable service shop.

NOTE: Disconnect all battery power to the engine before attempting to disconnect or remove the alternator(s) for repair.

W 40NA DC Control Circuit Wiring Diagram #37248
page 1 of 2

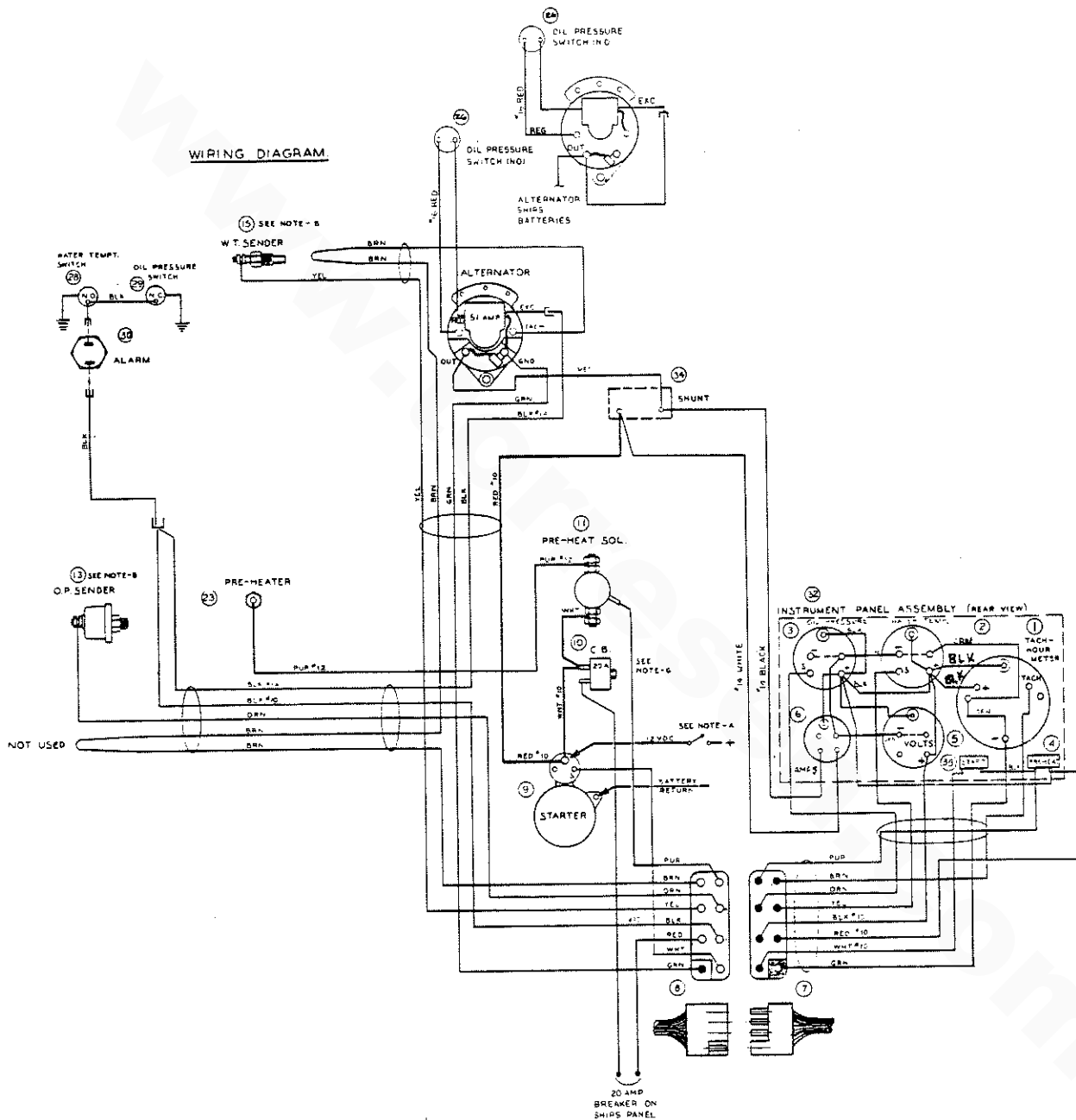

W 40NA DC Control Circuit Wiring Diagram #37248

page 2 of 2

SCHEMATIC DIAGRAM

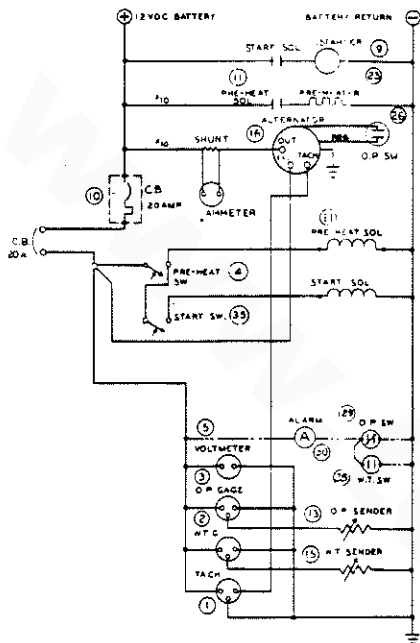

NOTES:

NOTES ON BUILDER/OWNER'S RESPONSIBILITY:

- ① AN ON-OFF SWITCH MUST BE INSTALLED IN THIS LINE TO DISCONNECT THE STARTER CIRCUIT FROM THE BATTERY IN AN EMERGENCY. WHEN LEAVING THE BOAT, 12VOLT DIESEL ENGINES TYPICALLY DRAW 200 TO 300 AMPS WHEN CRANKING. THE DURATION OF INDIVIDUAL CRANKING CYCLES SHOULD NOT EXCEED 30 SECONDS. A SWITCH WITH CONTINUOUS RATING OF 175 AMPS AT 12VDC WILL NORMALLY SERVE THESE FUNCTIONS, BUT SUCH A SWITCH MUST NEVER BE USED TO MAKE THE STARTER CIRCUIT.

OTHER NOTES:

- ② WARNING; SENDER CONNECTION: CONTACT WITH B+ MAY DAMAGE SENDER.
- ③ ALL RETURNS ARE THROUGH ENGINE BLOCK.
- ④ FOR WIRING OF AUXILIARY ALTERNATORS SEE THE FOLLOWING DIAGRAMS:
MOTOROLA 80 AMP, 11832
MOTOROLA 120 AMP, 11831
LEECE-NEVILLE 55 AMP, 16535
LEECE-NEVILLE 105 AMP, 16614
- ⑤ IF ADDITIONAL PRESSURE SWITCHES ARE REQ'D TO START BOAT ACCESSORIES, A FLEXIBLE HOSE MUST BE RUN FROM THE OIL PRESSURE MANIFOLD TO A NEARBY BULKHEAD AND ALL PRESSURE SWITCHES MOUNTED AT THE BULKHEAD.
- ⑥ APPLY SILASTIC OR TIGHT WOUND PLASTIC/TAPICE ELECTRICAL TAPE AROUND CONNECTORS CONNECTED.
- ⑦ CAUTION: THIS PRODUCT IS PROTECTED BY A MANUAL RESET CIRCUIT BREAKER LOCATED NEAR THE STARTER AND AS CLOSE TO THE SOURCE OF CURRENT AS POSSIBLE. EXCESSIVE CURRENT DRAIN ANYWHERE IN THE INSTRUMENT PANEL, WIRING, OR ENGINE WILL CAUSE THE BREAKER TO TRIP TO THE POINT. MOST ENGINE MODELS WILL SHUT DOWN BECAUSE THE OPENED BREAKER DISCONNECTS THEIR FUEL SUPPLY. THEREFORE THE BUILDER/OWNER MUST BE SURE THAT THE INSTRUMENT PANEL, WIRING AND ENGINE ARE INSTALLED TO PREVENT CONTACT BETWEEN ELECTRICAL DEVICES AND SALT WATER.

⑧ W40NA WIRING MODIFICATIONS AND PARTS SUPPLIED BY HANSEN MARINE ENGINEERING INC., MARBLEHEAD, MA 01945

35 153760	SWITCH, START	1
34	SHUNT	1
33 35502	PANEL, LESS INSTRUMENTS	1
32 35860	PANEL, COMPLETE	1
31		
30 15355	ALARM	1
29 30344	OIL PRESS. SW. N.C.	1
28 30128	WATER TEMP. SW. N.O.	1
27		
26 35318	SWITCH, O.P. - N.O.	2
25 20654	SPLITTER (OPTIONAL)	1
24		
23 11530	GLOW PLUGS W40	1
22		
21		
20	PANEL, LESS INSTRUMENTS	1
19	PANEL, COMPLETE	1
18 11582	SUPPRESSION VIB. ALT.	1
17 12559	TACH. KIT ALTERNATOR	1
16 24684	ALTERNATE 51 A.	1
15 18591	SENDER, WATER TEMP.	1
14		
13 24132	SENDER, OIL PRESSURE	1
12		
11 24480	SOLENOID, PRE-HEAT	1
10 24680	CIRCUIT BREAKER 30AMP	1
9 16722	STARTER, MARINE ENGINE	1
8 30082	HARNES, ENGINE	1
7 30148	HARNES, PANEL	1
6	AMMETER	1
5 33090	VOLTMETER	1
4 33764	SWITCH, PRE-HEAT	1
3 24133	OIL PRESSURE GAUGE	1
2 11585	WATER TEMP GAUGE	1
1 11519	TACHOMETER	1

ITEM/PART NO.	DESCRIPTION	QTY	SHORT/DESCRIPTION
	WESTERBEKE CORPORATION		
	AVON MA 02322		
	NTS		
	WIRING DIAG-W40NA		
	REVISION	37248	

COOLING SYSTEM

Description

Westerbeke marine diesel engines are designed and equipped for fresh water cooling. Heat produced in the engine by combustion and friction is transferred to fresh water which circulates throughout the engine. This circulating fresh water cools the engine block and its internal moving parts. The heat is transferred externally from the fresh water to sea water by means of a heat exchanger, similar in function to an automotive radiator. Sea water flows through the tubes of the heat exchanger while fresh water flows around the tubes; engine heat transferred to the fresh water is conducted through the tube walls to the sea water which is then pumped into the exhaust system where finally it is discharged overboard. In other words, the engine is cooled by fresh water, the fresh water is cooled by sea water, and the sea water carries the transferred heat over the side through the exhaust system. The fresh water and sea water circuits are independent of each other. Using only fresh water within the engine allows the cooling water passages to stay clean and free from harmful deposits. The two independent circuits and their components are discussed in the following paragraphs.

Fresh Water Circuit

NOTE: Refer to paragraphs **A** and **B** in this section for the recommended antifreeze and water mixture to be used as the fresh water coolant, and for information on filling the fresh water system.

Illustrated below is a typical Westerbeke engine's cooling system. Both fresh water and sea water flow through their independent cooling circuits.

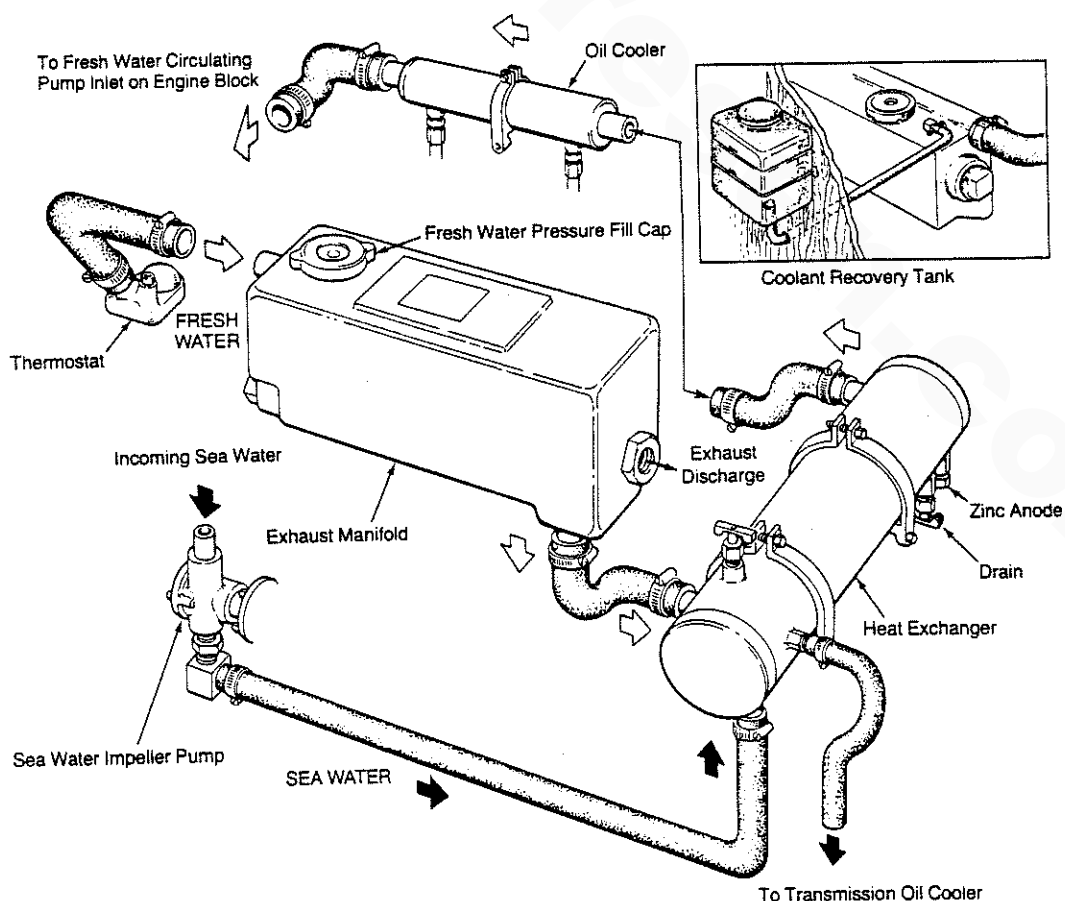

Electrical System

The electrical system should be checked to ensure that all wiring harnesses are tied down properly with clamps or plastic ties, spaced at intervals close enough to prevent chafing from vibration. Check to ensure that all the engine's harness connections are tight and that they are connected to the appropriate terminals.

WARNING

Do not smoke or allow an open flame near batteries. Lead acid batteries emit hydrogen, a highly-explosive gas. Turn off the emergency switch in the positive line of battery.

Make sure the positive (+) battery connection is connected to the battery connection of the starting solenoid. The negative (-) battery connection should be connected to the system ground (the engine block).

WARNING

When servicing the battery or checking the electrolyte level, wear rubber gloves, a rubber apron, and eye protection. Battery acid may splash on the skin or into the eyes inadvertently when removing electrolyte caps.

Check level and specific gravity of battery electrolyte to ensure maximum engine starting efficiency. Make sure terminals are clean and tight.

Ventilation

The ventilation requirements of the engine include the following: combustion air is required for the engine's cylinders and ventilating air is required to clear the bilges below the engine, as well as the compartment in which the engine is located, of engine heat and potentially toxic and flammable diesel fumes. Refer to the "SPECIFICATIONS" section of this manual for airflow requirements, page 8.

PREPARATION FOR STARTING

This section of the manual provides the operator with preparation, initial starting, break-in, starting (cold or warm), and stopping procedures. Follow the procedures as presented, for the conditions indicated, and your Westerbeke engine set will give you reliable performance and long service life.

Fill the engine with oil by pouring engine oil through the oil filler cap. Fill the engine up to or near the upper limit on the dipstick (the installation angle may have an effect on the dipstick reading). Select readily available lubricating oil with an API specification of CC or CD and an SAE number suitable for the temperature in your operating area (see page 47). For the quantity of oil needed in this engine, refer to the "SYSTEM SPECIFICATION" section of this manual, page 8.

Fill the transmission to the **FULL** mark on the dipstick with the correct lubricant. (Refer to the "SYSTEM SPECIFICATIONS" section of this manual, page 9.)

Each unit is supplied with a coolant recovery kit (#24977) as standard equipment, to which the following applies:

- A. Remove the pressure cap from the engine's exhaust manifold and slowly fill the engine's cooling system with a mixture of water and antifreeze suitable for your temperature zone. (See the "COOLING SYSTEM" section of this manual, page 42.) Operate the engine and observe the coolant level in the manifold. Maintain this level to the base of the filler neck. Once the engine reaches its operating temperature (170 - 190° F), ensure that there is coolant flow to the domestic water heaters when installed. Top off the cooling system and install the pressure cap.
- B. Make sure the plastic recovery tank is properly mounted near the unit (with the bracket provided), in a location where it can be monitored and filled easily. The recovery tank should be mounted at manifold level or above. In these installations that require it, the plastic recovery tank can be mounted below the exhaust manifold's level.
- C. Add coolant to the plastic tank after the engine has been started and operating temperature has been reached, to ensure that all air is expelled from the manifold and the engine's cooling system. With the manifold filled and the pressure cap installed, fill the plastic recovery tank half full. Monitor daily and add coolant as needed.

Fill the fuel tank with a good grade of No. 2 diesel fuel and prime the fuel system up to the engine (see page 32). When returning fuel is free of air, the engine's fuel system is bled and the engine is ready to start.

Ensure that the Installation Checks have been made in accordance with those specified in the "INSTALLATION CHECKS" section of this manual (refer to page 10).

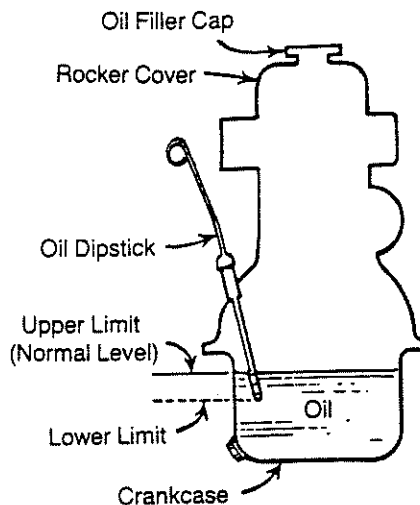

Starting System

The W 40NA diesel engine uses an electric starter for both normal and cold weather starting. A cold start aid system is furnished on the W 40NA engine as standard equipment (part #36258). Both the thermostart device and the cold start aid are located on the air intake, manifold side of the engine. The PREHEAT button energizes the thermostart device assists in vaporizing the fuel at the intake manifold inlet. The vaporized diesel fuel is drawn into the cylinder during cranking and allows for easy combustion during compression. This process allows the engine to start rapidly and reduces wear on the starter.

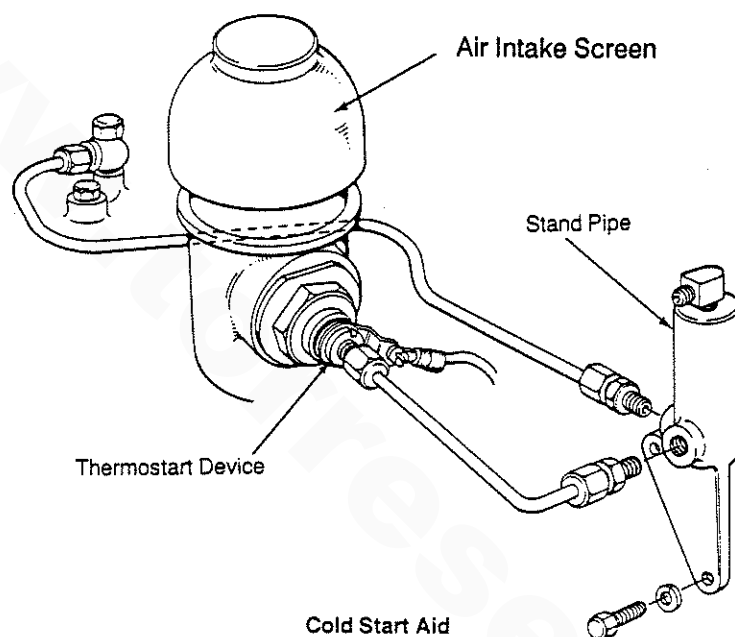

The W 40NA engine's electrical system is designed so that the PREHEAT button must be depressed for the time specified in the "Preheat" chart shown on page 26. While keeping the PREHEAT button depressed, the START button must be pressed to crank the engine.

NOTE: The START button will not crank the engine unless the PREHEAT button is depressed at the same time. When the PREHEAT button is depressed, the thermostart device is activated. USE THE PREHEAT BUTTON ONLY AS NECESSARY. Overuse of the PREHEAT button will overheat the thermostart device.

Refer to the "STARTING PROCEDURE" section of this manual for starting instructions, page 26

DESCRIPTION OF INSTRUMENT PANEL

Westerbeke 40NA engines are supplied with instrument panels. Read the following instruction carefully before operating the engine.

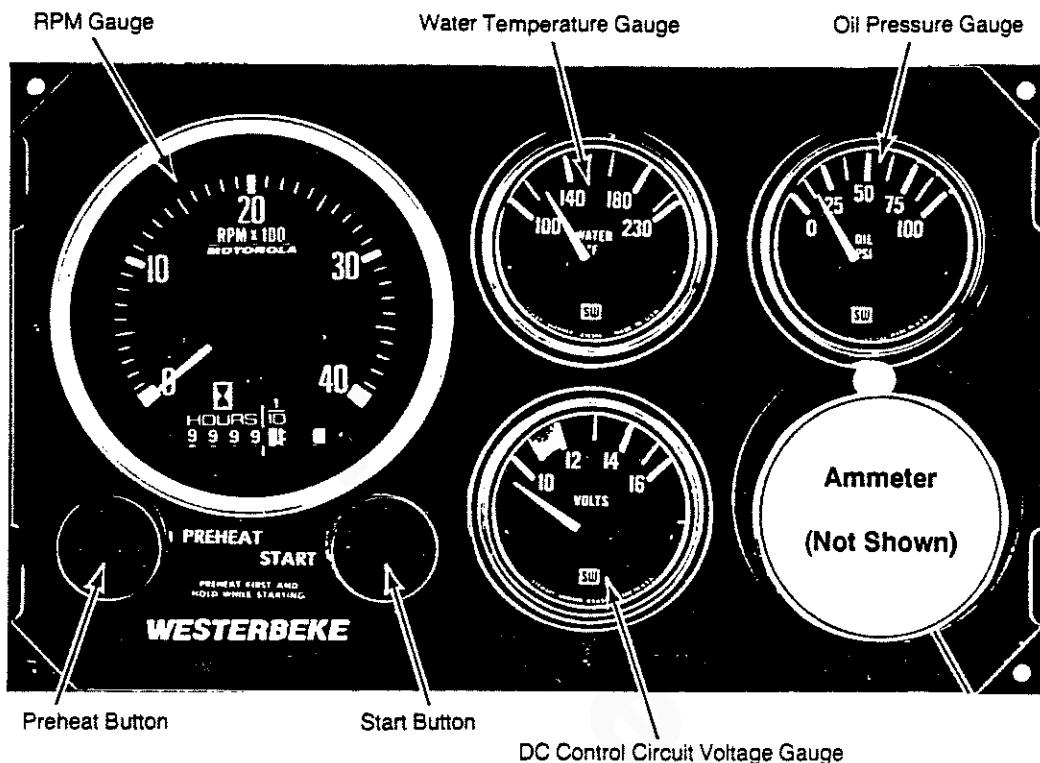

General

The manually-controlled panel is equipped with an RPM gauge with an ELAPSED TIME meter which measures the engine's running time in HOURS and in 1/10 hours. The panel also includes a water temperature gauge which indicates water temperature in degrees Fahrenheit (WATER ° F), an oil pressure gauge which measures the engine's oil pressure in pounds per square inch (OIL PSI), a DC control circuit voltage gauge which measures the system's DC voltage (VOLTS), and a DC Ammeter which allows the operator to monitor amperage in the DC charging circuit. All gauges are illuminated when the circuit breaker is turned ON and remain illuminated while the engine is in operation. The panel also contains two rubber-booted push buttons, one for PREHEAT and one for START.

1. **Circuit Breaker (Not Shown):** The Circuit Breaker, positioned somewhere in the vessel so it may be easily reached, provides power only to the instrument cluster. Refer to the "STOPPING PROCEDURE" section of this manual, page 28.
2. **PREHEAT:** The PREHEAT button energizes the alternator's EXC terminal and the intake manifold's thermostart device. This button also energizes the START button.
3. **START:** The START button, when pressed, energizes the starter's solenoid which cranks the engine. This button will not operate electrically unless the PREHEAT button is pressed and held at the same time.

4. Ammeter Gauge: An Ammeter gauge is provided by the Dealer and is located in the lower right hand corner of the instrument panel. (The Ammeter is not shown in the photograph on the preceding page.)

NOTE: An alarm buzzer is supplied with every panel. The installer is responsible for electrically connecting the buzzer to the four-pin connection on the engine's electrical harness. The installer is also responsible for installing the buzzer in a dry location so that it will be audible to the operator should it sound while the engine is running. The buzzer will sound when the Circuit Breaker is turned ON and should silence when the engine has started and when the engine's oil pressure rises above 15 psi.

5. Water Temperature Gauge: This gauge is graduated in degrees Fahrenheit and is illuminated while the main engine circuit breaker is turned ON. The engine's normal operating temperature is 170 - 190° F (77 - 88°C).
6. Oil Pressure Gauge: This gauge is graduated in pounds per square inch (PSI) and is illuminated while the main engine circuit breaker is turned ON. The engine's normal operating oil pressure ranges between 30 - 60 PSI.

NOTE: When the engine is manually shut down, and the engine's circuit breaker is turned OFF, the water temperature gauge will continue to register the last temperature reading indicated by the gauge before electrical power was turned OFF. The temperature gauge will once again register the engine's true temperature once electrical power is restored to the gauge.

STARTING PROCEDURE

1. Place the transmission in the NEUTRAL position and advance the throttle to its full open position for a cold engine, and partially open for a warm engine.
2. Turn the Circuit Breaker to the ON position. Make sure the push/pull stop lever has been returned to the RUN position.
3. Depress and hold the PREHEAT switch. Preheat according to the following chart:

Atmospheric Temperature	Preheating Time
+ 41° F (+ 5° C) or higher	Approx. 10 sec.
+ 41° F (+ 5° C) to + 23° F (- 5° C)	Approx. 20 sec.
+ 23° F (- 5° C) or lower	Approx. 30 sec.
Limit of continuous use	1 minute.

The instrument panel includes a DC control circuit voltage gauge. A properly operating thermostart device is indicated when the voltmeter registers a voltage drop when the PREHEAT button is depressed. This voltage drop will be slight but noticeable. If the voltmeter indicates no voltage drop at the time the PREHEAT button is depressed, then the thermostart device could be defective or the preheat circuit is faulty (check for any loose connections).

While holding the PREHEAT button depressed, depress the START button. The starter motor will run, thereby cranking the engine. As soon as the engine runs, release the START button and PREHEAT button.

Should the engine not start when the START button is depressed for 10 to 12 seconds, release both buttons and wait 30 seconds; repeat the previous procedure. Never run the starter motor for more than 30 seconds at a time.

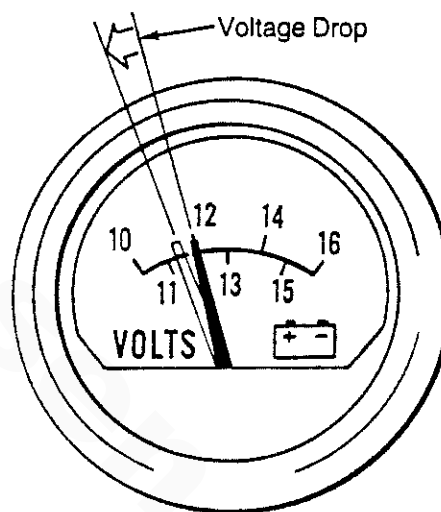

DC Control Circuit Voltage Gauge

CAUTION

Prolonged cranking intervals without the engine starting can result in filling the engine-mounted exhaust system with sea water coolant. This may happen because the sea water pump is pumping sea water through the sea water cooling system during cranking. This sea water can enter the engine's cylinder's by way of the exhaust manifold once the exhaust system fills. Prevent this from happening by closing the sea water supply through-hull shut-off, drain the exhaust muffler, and correct the cause for the excessive engine cranking needed to obtain a start. Engine damage resulting from this type of sea water entry is not a warrantable issue; the owner/operator should keep this in mind.

Once the engine starts, move the throttle into a fast idle position (1000 - 1200 rpm). Check your instrumentation for proper engine operation. Make sure that sea water discharges along with the exhaust discharge.

NOTE: Some unstable running may occur in a cold engine, but this condition should smooth out as the operating temperature of 170 - 190° F (77 - 88° C) is reached.

Transmission Shifting

To shift the transmission, use the remote control shifting lever located in the cockpit. This remote control shifting lever rotates the shifting lever on the side of the standard transmission. Rotating the shifting lever in a counterclockwise direction places the transmission in FORWARD gear. To shift the transmission in REVERSE gear, rotate the shifting lever in a clockwise direction through NEUTRAL into REVERSE.

Remember:

FORWARD GEAR: Rotate the lever **COUNTERCLOCKWISE**.

REVERSE GEAR: Rotate the lever **CLOCKWISE** through NEUTRAL into REVERSE.

For a more detailed description of the HBW transmission's operation, refer to the "HBW TRANSMISSION" section of this manual, page 50.

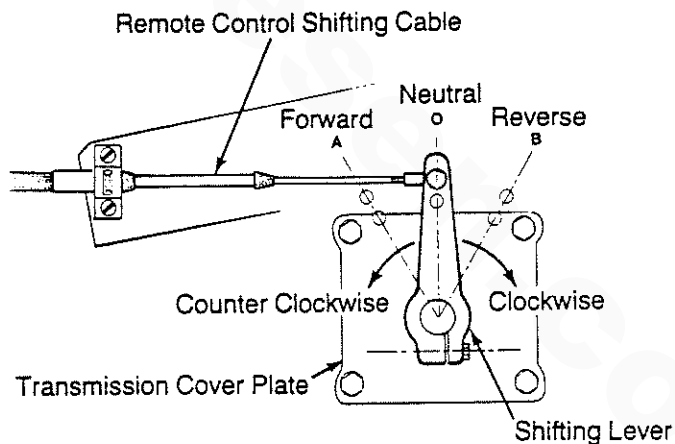

Transmission Shifting Positions

STOPPING PROCEDURES

In the cockpit of the boat, there is a tee handle or a knob-type shut-off control. When this control is pulled **OUTWARD**, the control will **STOP** the engine. The other end of the shut-off control is attached to a lever on the top of the fuel injection pump. (Pushing the shut-off control fully inward will place the engine in the **RES-TART - RUN** position.

When the engine is stopped, turn the Circuit Breaker located in the vessel to the **OFF** position. If the Circuit Breaker is left **ON**, the battery will discharge.

CAUTION

DO NOT attempt to shutdown the engine by turning the Circuit Breaker **OFF**. The Circuit Breaker only provides power to the instrument panel and to the DC alternator; the engine will continue running even if the Circuit Breaker is turned **OFF**. Stop the engine by pulling the shut-off control fully **OUTWARD**.

Engine Break-In Procedures

Although your engine has experienced a minimum of one hour of test operations to ensure accurate assembly and proper operation of all systems, break-in time is required. The service life of your engine is dependent upon how the engine is operated and serviced during its initial hours of use.

Your new engine requires approximately 50 hours of initial conditioning operation to break in each moving part in order to maximize the performance and service life of the engine. Perform this conditioning carefully, keeping in mind the following:

1. Start the engine according to the "STARTING PROCEDURE" section found on page 26; run the engine at fast idle while checking that all systems (sea water pump, oil pressure, battery charging) are functioning.
2. Allow the engine to warm up (preferably by running at fast idle) until the water temperature gauge moves into the 130-140° F range.
3. While using the vessel under power, vary the engine's rpm cruise settings during the engine's initial 25 hours of operation.
4. Avoid rapid acceleration, especially with a cold engine.
5. Use caution not to overload the engine. The presence of a gray or black exhaust, and the inability of the engine to reach its full rated speed, are signs of an overload (that is, a propeller that is too large).
6. During the next 25 hours, the engine may be operated at varying engine speeds, with short runs at full rated rpm. Avoid idling the engine for prolonged periods of time.

Breaking-in a new engine basically involves seating the piston rings to the cylinder walls. This cannot be accomplished by long periods of running at Idle, nor by early running at full speed.

Idle running may glaze the cylinder walls, resulting in excessive oil consumption and smoky operation. Excessive speed or heavy overloading, especially with a cold engine, may cause scoring of the cylinder walls, producing similar results.

As indicated above, operate the engine in moderation during the 50-hour break-in period. (On one hand don't baby the engine, but on the other hand, however, don't abuse it.)

Starting Under Normal Conditions

Follow the procedure below for normal starting of the engine:

1. Check the engine and transmission lubricant levels and fill, if necessary.
2. Make sure there is sufficient fuel on board. Keep fuel tank(s) as full as possible. Check the fuel filters and water separators for the presence of contaminants and/or water. Drain and clean them as needed.
3. Check the coolant level in the plastic recovery tank. Add coolant solution as needed.

NOTE: Excessive loss of coolant from the plastic recovery tank indicates a cooling system leak. Check the entire cooling system and the recovery tank and its connections at the exhaust manifold, and pressurize the system to locate the leak. In cases of excessive coolant loss, the system must be refilled as outlined under the "PREPARATION FOR STARTING" section of this manual, page 22.

4. Check for oil and fuel leaks, particularly if signs of such leaks are found on the bottom of the engine or below the engine.
5. When checking your engine's coolant and oil levels, check the engine for any noticeable abnormalities such as loose or missing bolts, loose brackets and mounts, loose hose clamps, chafed wires, or any other components that exhibit wear or are loose.

Start the engine in accordance with the "STARTING PROCEDURE" instructions found on page 26, and allow the engine's operating temperature to reach 140 - 150° F before operating the engine underway.

Starting Under Cold Conditions

Under extremely cold temperatures, the following conditions can occur. Follow the instructions listed below when operating your engine in cold weather.

LUBRICATING OIL TURNS VISCOUS - Make certain that the lubricating oil used conforms with the ratings for the prevailing atmospheric temperature. Refer to the "LUBRICATION SYSTEM" section of this manual, page 47 for an atmospheric/oil viscosity specification table.

VOLTAGE ACROSS THE BATTERY TERMINALS DROPS - Make certain that the battery is fully charged to minimize voltage drop across the battery terminals.

THE TEMPERATURE OF THE INTAKE AIR IS LOW AND THE COMPRESSION TEMPERATURE DOES NOT RISE ENOUGH - Allow the thermostart device to operate sufficiently to aid in starting during the preheat period whenever the temperature of the intake air is low and when the compression temperature within the cylinders will not rise quickly during cranking. Refer to the "Preheat" chart found in the "STARTING PROCEDURE" section of this manual, page 26.

www.torresen.com

Fresh water is pumped through the engine by a belt-driven fresh water circulating pump, absorbing heat from the engine. The fresh water coolant circulates through the engine's block absorbing heat, then passes through the thermostat into the exhaust manifold, to the heat exchanger where it is cooled, and then is returned to the engine block through the suction side of the fresh water circulating pump. When the engine is started cold, external fresh water flow is prevented by the closed thermostat (although some fresh water flow is bypassed around the thermostat to prevent the exhaust manifold from overheating). As the engine warms up, the thermostat gradually opens, allowing full flow of the engine's fresh water coolant to flow unrestricted to the external portion of the cooling system.

A. Fresh Water Coolant (Antifreeze) Mixture.

A freshwater and antifreeze mixture should be used year-round in the fresh water cooling system. Water, when it freezes, expands sufficiently to split the heat exchanger and crack the engine block. A water/antifreeze mixture of proper concentration will prevent freezing (see below for an antifreeze/water mixture chart).

Use soft water with few impurities, such as tap water (potable water) or rainwater. Never use hard or foul water. Use of hard water or water containing impurities will lead to the collection of scale in the engine and heat exchanger which will reduce the cooling system's efficiency.

Antifreeze of poor quality or without rust inhibitors will cause corrosion within the cooling system. Always use antifreeze which is compatible with aluminum cooling system components and is made by a reliable manufacturer. Never mix different brands of antifreeze.

Make sure that the cooling system of the engine is well cleaned before adding antifreeze. Recommended antifreeze for year round use is ZEREX or PRESTONE with rust inhibitors.

In order to control the concentration of the mixture, mix the antifreeze and freshwater thoroughly before adding it to the cooling system.

ANTIFREEZE CONCENTRATION DATA

Antifreeze Concentration	%	13	23	30	35	45	50	60
Freezing Temperature	° F	23	14	5	- 4	- 22	- 40	- 58
	(° C)	(- 5)	(-10)	(-15)	(- 20)	(- 30)	(- 40)	(- 50)

NOTE: An antifreeze concentration should be selected on the basis of a temperature which is about 10° F (5° C) lower than the actual atmospheric temperature expected.

B. Filling the Fresh Water System

A coolant recovery tank kit is supplied with each Westerbeke diesel engine. The purpose of this recovery tank is to allow for engine coolant expansion and contraction, during engine operation, without the loss of coolant and without introducing air into the cooling system.

This coolant recovery tank should be installed at, or above, engine manifold level, in a location where it can be easily monitored and where coolant can be easily added if needed (see the figure below). A stainless steel mounting bracket is supplied with each kit along with a 30-inch length of clear plastic hose and clamps to connect the hose between the engine's manifold fitting to the hose spud on the base of the recovery tank.

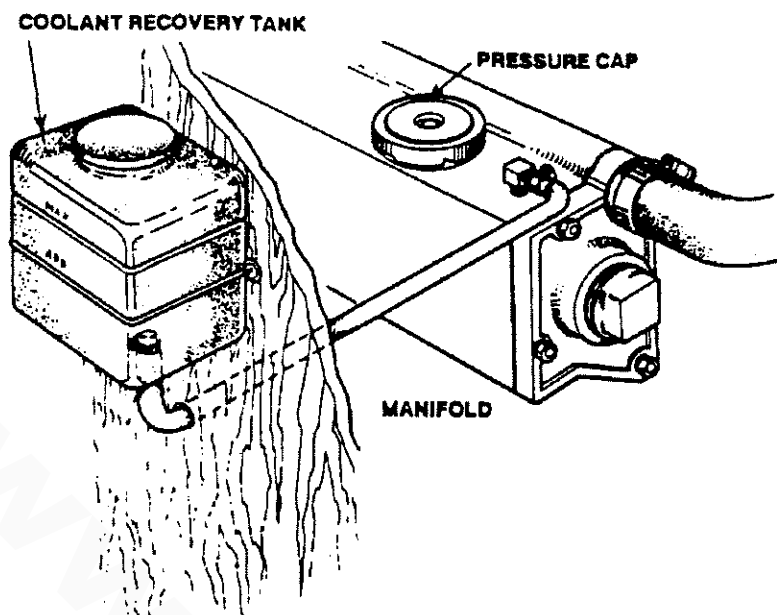

Coolant Recovery Tank, Recommended Installation

Coolant from the engine, when heated during engine operation, will expand, lifting the spring-loaded manifold pressure cap, and enter the coolant recovery tank by way of the hose connecting the recovery tank to the exhaust manifold.

When the engine is shut down and cools, a small check valve in the pressure cap is opened by the contraction of the engine coolant, allowing some of the coolant in the recovery tank to be drawn back into the engine's cooling system, free of air and without loss.

FUNCTION OF MANIFOLD PRESSURE CAP

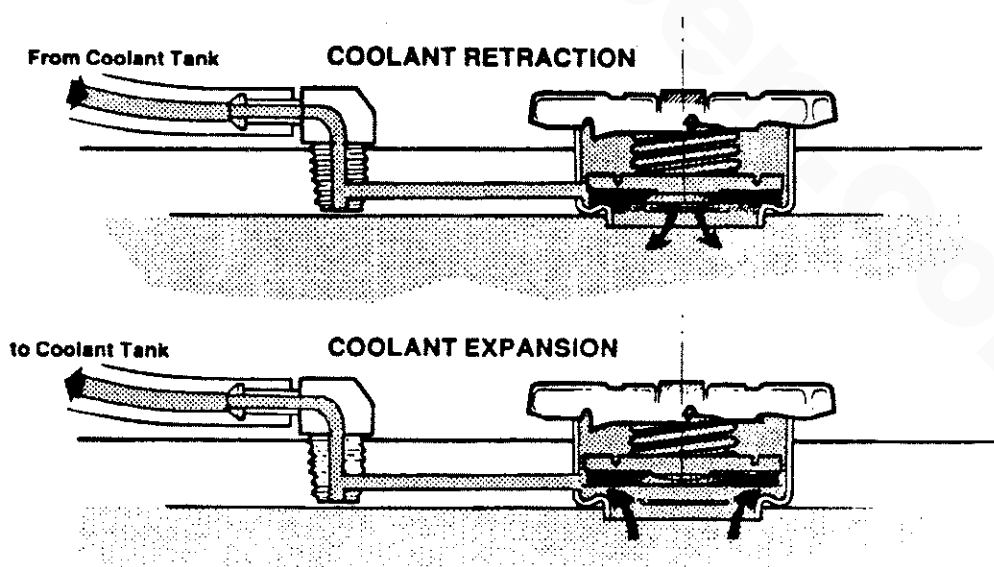

Thermostat

Generally, thermostats are of two types. One is simply a choking device which opens and closes as the engine's temperature rises and falls. The second type has a bypass mechanism. Usually this is a disc on the bottom of the thermostat which moves downward to close off an internal bypass passage within the head. Since 1980, each type of thermostat has a hole punched through it. The hole is a bypass to prevent the exhaust manifold from overheating during the engine's warm-up. Replacement thermostats must have this design characteristic.

Sea Water Circuit

The sea water flow is created by a gear-driven, positive displacement, neoprene impeller pump. The pump draws sea water directly from the ocean through the sea cock and sea water strainer and passes the water to the heat exchanger's sea water inlet. The sea water passes through the heat exchanger's tubes, from which heat from the fresh water system is absorbed, and then the sea water is discharged from the cooling system overboard through the water-injected wet exhaust system.

A zinc anode, or pencil, is located in the sea water cooling circuit within the heat exchanger. The purpose of the zinc anode is to sacrifice itself to electrolysis action taking place in the sea water cooling circuit, thereby reducing the effects of electrolysis on other components of the system. The condition of the zinc anode should be checked monthly and the anode cleaned or replaced as required. Spare anodes should be carried on board. Be sure to clean zinc debris from the area inside of the heat exchanger where the zinc anode is positioned.

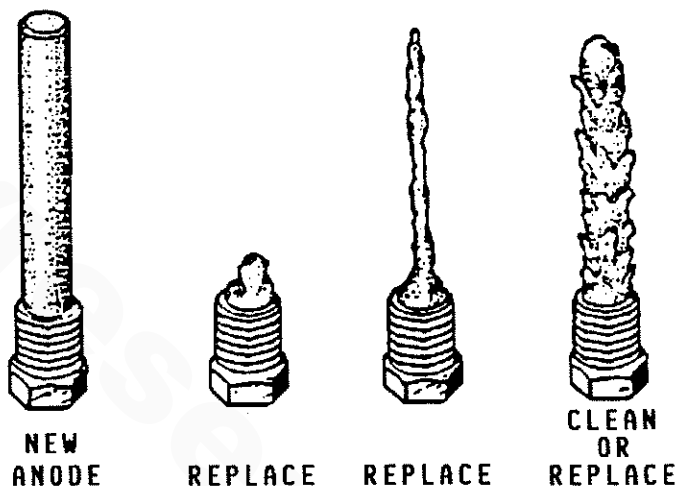

Zinc Anode Conditions

Sea Water Pump

The sea water pump is a self-priming, gear-driven rotary pump with a non-ferrous housing and a neoprene impeller. The impeller has flexible vanes which wipe against a curved cam plate within the impeller housing, producing the pumping action. On no account should this pump be run dry. There should always be a spare impeller and impeller cover gasket aboard (an impeller kit). Sea water failures occur when lubricant (sea water) is not present. Such failures are not warrantable and the operator's are cautioned to ensure that sea water flow is present at start-up.

Alternator and Water Pump Drive Belt Tension

WARNING

Never attempt to adjust the drive belt's tension while the engine is in operation.

CAUTION

Excessive alternator and water pump drive belt tension can cause rapid wear of the belt and reduce the service life of the fresh water pump and alternator shaft bearings. Excessive slack or the presence of oil on the belt can cause belt slipping, resulting in high operating temperature, as well as insufficient alternator output.

The alternator and water pump drive belt(s) is/are properly adjusted if the belt can be deflected no less than 3/8 inch and no more than 1/2 inch (10 mm, 12 mm) as the belt is depressed with the thumb at the midpoint between the two pulleys on the longest span of the belt. (See the figure below.) A spare drive belt(s) should be carried on board.

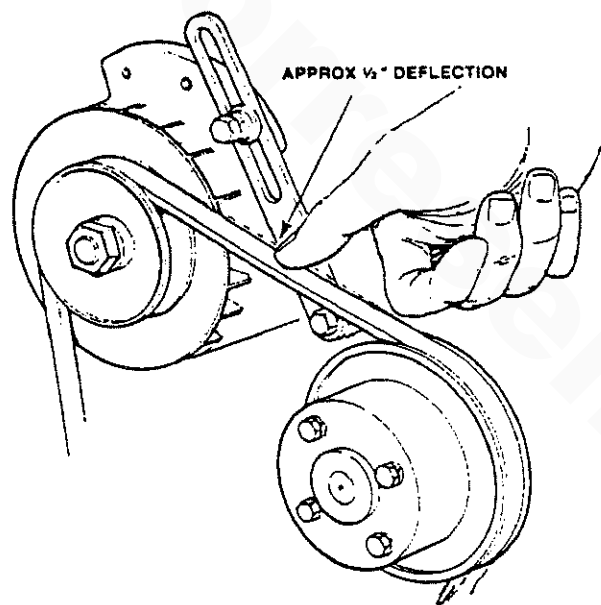

Alternator and Water Pump Belt Tension

LUBRICATION SYSTEM

Engine Oil

For engine lubrication, use lubricating oil designated for diesel service. These oils are classified according to the API specifications into service grades CA, CB, CC and CD. The use of CC or higher (CD) grades, made by well-known manufacturers is recommended. The oil selected should be used thereafter.

Engine Oil Viscosity (SAE Number)

Use an oil having a viscosity best suited to the atmospheric temperature. Use of an all-season oil SAE 10W-30 with minimum viscosity change under different temperatures is suggested.

<u>Atmospheric Temperature</u>	<u>Viscosity</u>
68° F (20° C) or higher	SAE 30 or 10W-30
41° F (5° C) - 68° F (20° C)	SAE 20 or 10W-30
41° F (5° C) - or lower	SAE 10W-30

NOTE: Do not use an engine lubricating oil with an SAE number greater than 30 in the engine.

Oil Pressure

The engine's oil pressure, during operation, is indicated by the oil pressure gauge on the instrument panel (see page 24).

During normal operation, the oil pressure will range between 30 and 60 psi. At idle speed, the oil pressure will range between 20 and 35 psi. At the time of cranking, the oil pressure will rise proportionately with speed.

NOTE: A newly started, cold engine can have an oil pressure reading upwards of 60 psi. A warmed engine can have an oil pressure reading as low as 35 psi. These readings will vary depending upon the speed at which the engine is running.

Engine Oil Change (to include filter)

1. Draining the Oil Sump

Remove the oil drain hose from its attachment bracket and lower the end of the hose into a container to allow the oil to drain, or attach a pump to the drain hose and pump the oil out. Make sure the oil drain hose is properly secured in its holder after all of the old oil has been removed.

Always observe the old oil as it is removed. A yellow/gray emulsion indicates the presence of water in the oil. Although this condition is rare, it does require prompt attention to prevent serious damage. Call a competent mechanic should water be present in the oil. Sea water present in the oil can be the result of a fault in the exhaust system attached to the engine and/or a siphoning through the sea water cooling circuit into the exhaust, filling it up into the engine (refer to the installation illustrations on page 15).

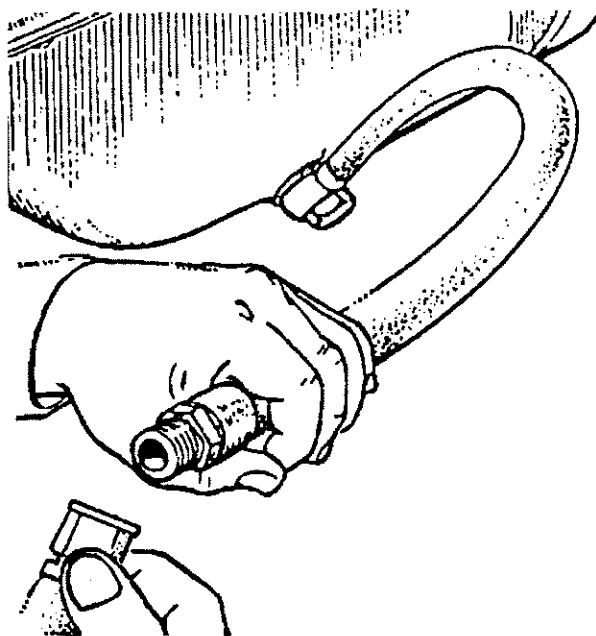

2. Replacement of the Oil Filter

When removing the used oil filter, you may find it helpful and cleaner to punch a hole in the upper and lower portion of the old filter to drain the oil from it into a container before removing it. This helps to lessen spillage. A small style automotive filter wrench should be helpful in removing the old oil filter. Place some paper towels and a plastic bag around the filter when unscrewing it to catch any oil left in the filter. (Oil or any other fluid on the engine reduces the engine's cooling ability. Please keep your engine clean.) Inspect the old oil filter as it is removed to make sure that the rubber sealing gasket came off with the old oil filter. If this rubber sealing gasket remains sealed against the engine block, gently remove it. The replaceable cartridge-type oil filter requires no cleaning inside, so it may be properly disposed of.

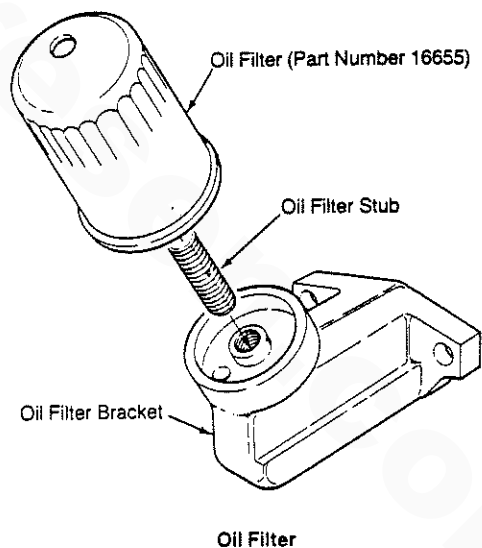

When installing the new oil filter element, wipe the filter gasket's sealing surface on the engine block free of oil and apply a thin coat of clean engine oil to the rubber gasket on the oil filter. Screw the filter onto the threaded oil filter stub, and then tighten the filter firmly by hand. See the "TORQUE SPECIFICATIONS" section of this manual for the proper oil filter tightening specification, page 61.

3. Filling the Oil Sump

Add fresh oil through the oil filler cap on the valve cover (refer to the photographs on pages 5 and 6 for the location of the oil filler cap and lube oil dipstick). After refilling the oil, run the engine for a few moments while checking the engine's oil pressure. Ensure there is no leakage around the new oil filter or from the oil drain system, and then stop the engine. Then check the quantity of oil with the lube oil dipstick. Fill to, but not over, the high mark on the dipstick, should the engine require additional oil.

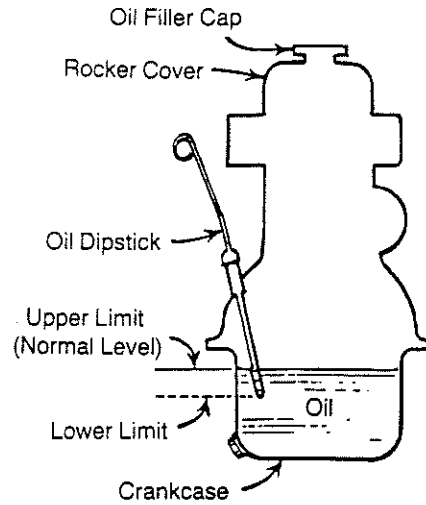

NOTE: Immediately after an oil filter change and oil fill, run the engine to ensure that the oil pressure is normal and that there are no oil leaks around the new oil filter. Check the oil pressure by observing the oil pressure gauge in your instrument panel.

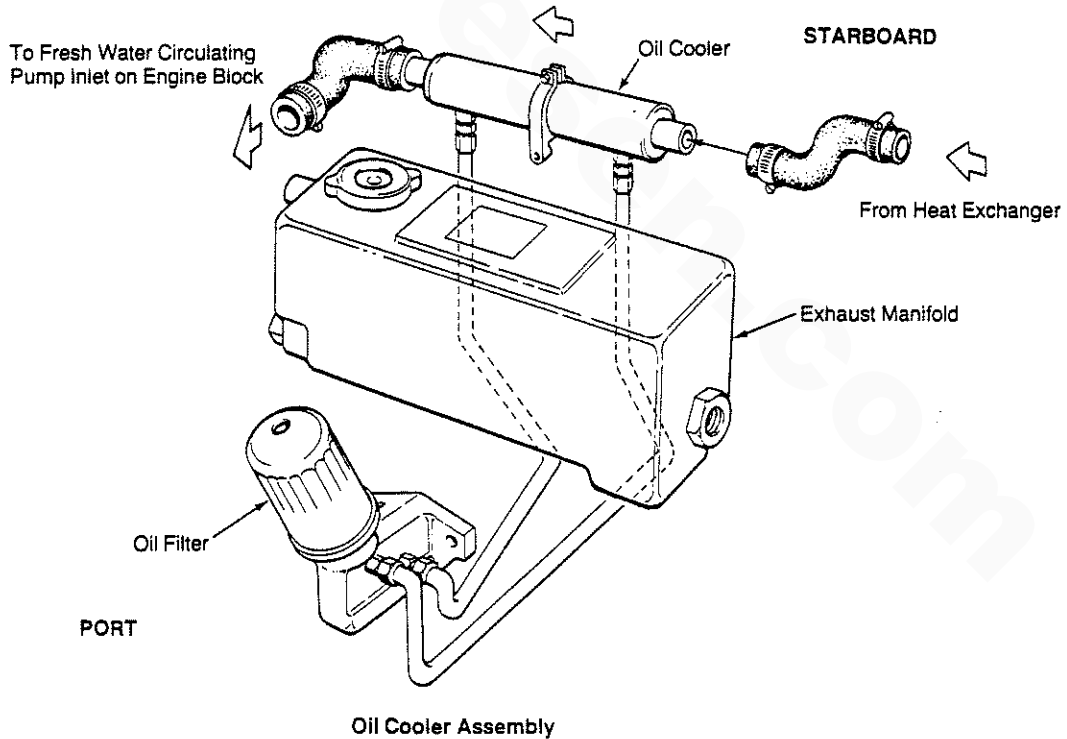

THE HBW 150 TRANSMISSION

General

The HBW 150 transmission is equipped with a positively-driven, mechanically-operated helical gearing system. The servo-operated multiple-disc clutch requires only a minimum effort to change drives. This feature makes the transmission suitable for a single-lever remote control with a rod linkage, such as a Morse or Bowden cable. For safety reasons, the transmission is **NOT** filled with transmission fluid for shipment. Before leaving the factory, however, each transmission is thoroughly tested with fluid in the transmission. This testing, among other things, provides all internal parts with a coating of transmission fluid. This fluid acts as a preservative, providing reliable protection against corrosion for at least one year if the transmission is properly stored.

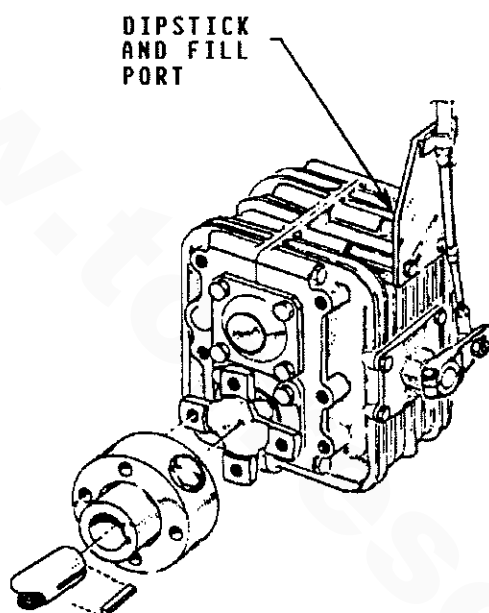

Lubrication

The HBW 150 transmission is an immersion-lubricated type. Fill the transmission up to or near the top of the machined notch cut on the dipstick with approximately 0.60 U.S. quarts (0.56 liters) of automatic transmission fluid (ATF). The HBW 150 has its own dipstick and oil sump.

Change the transmission fluid after the first 30 hours of engine operation and thereafter every 250 hours (or once per year, minimum). The HBW 150 transmission has a drain plug for draining the old transmission fluid. To ensure that most of the old fluid is drained from the transmission, run the engine in NEUTRAL for approximately 10 to 15 minutes so the transmission fluid may warm and flow better from the transmission. This transmission fluid may also be removed by inserting a small tube through the dipstick opening (where the transmission fluid is added) and attaching a pump onto the tube so the old fluid may be sucked out.

NOTE: When removing the dipstick or drain plug, make sure the thin aluminum sealing washer, located under the plug, is not lost. Leakage will result if the sealing washer is not present.

NOTE: To check the transmission fluid level, remove the dipstick and wipe off all transmission fluid on the dipstick, and place the dipstick back in the hole where it was removed, making sure that the base of the dipstick's threaded portion rests on the transmission housing. Now remove the dipstick and see where the fluid measures on the dipstick. If the transmission's fluid level lies below the notch, add enough transmission fluid to raise the level back up to the notch. Do not overfill the transmission.

DO NOT screw the dipstick into this hole to check the transmission fluid level. Screw the dipstick into this hole only after an accurate reading of the fluid's level has been taken. Make sure that the dipstick is screwed in before and while the engine is operating. Ensure that the sealing washer is present and that the dipstick is not cross-threaded or overtightened.

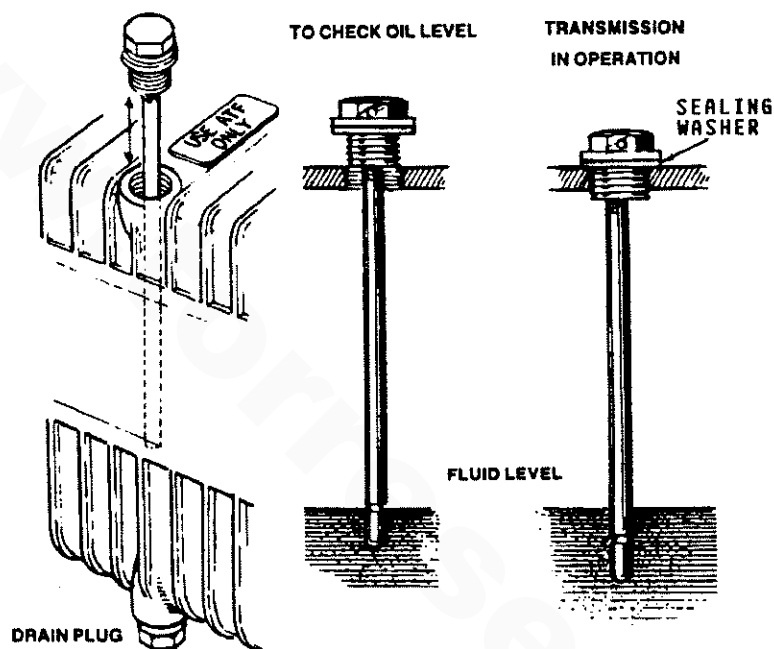

The Transmission drain plug is located directly below the dipstick and is the same size hex head as the dipstick. This drain plug also has a sealing washer.

Maximum tightening torque for the Drain Plug and Dipstick: 25 lb-ft (3.45 kg-m)

Alignment

Misalignment between the transmission's coupling and the propeller shaft's coupling can create serious problems. Ensure that the alignment procedures outlined in the "Propeller Coupling," the " Propeller, " and the " Alignment of the Engine" sections of this manual are followed, pages 13 and 14.

Controls

The only controls required to operate the transmission is a single lever remote control cable using a 33C cable. The cable should be attached at right angles to the gear box lever using the cable bracket supplied with the unit. Both the gear box lever and the remote control lever must be in the NEUTRAL position when the cable is attached to the gear box lever. This allows the remote cable an equal throw distance to shift the gear box into FORWARD or into REVERSE from the NEUTRAL position without running out of cable. Allow approximately 1.18 inches (1 3/16) minimum of cable throw from the NEUTRAL position on the transmission's gear box lever to the each of the two drive positions.

NOTE: If the throw distance (or travel) of the remote cable is too short, the gear box lever cannot fully engage the transmission into FORWARD (A) or REVERSE (B). In this situation, the transmission's clutch plates will wear prematurely and the transmission will eventually fail.

NOTE: Excessive throw distance in the remote control lever is not detrimental to the transmission. Note that the position of the remote control lever should align with the NEUTRAL marking on its bracket when the transmission is really in NEUTRAL.

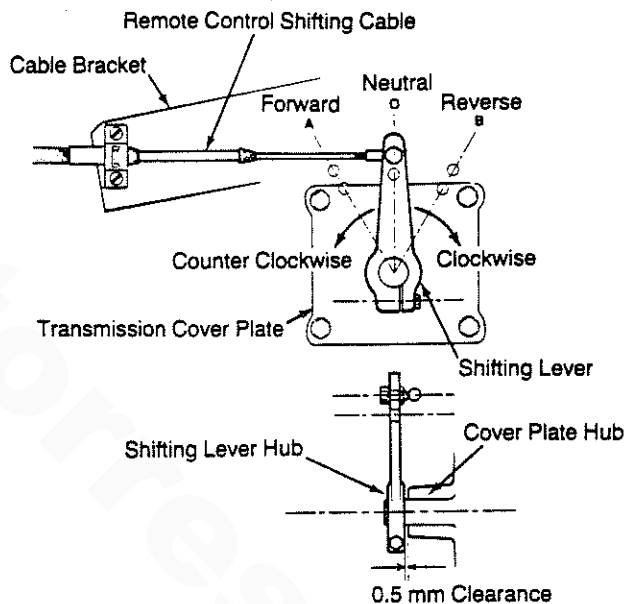

Transmission Shifting Positions

Shifting

To shift the transmission from NEUTRAL into FORWARD, exert a *heavy push* to the remote control lever. A gentle throw may not carry enough force to actually shift the transmission's internal gears. A gentle throw is signalled by the transmission not engaging into the desired drive. Make sure the remote control lever is lubricated at least once each operating season. Shift the transmission while the engine is running at 1200 rpm or below. The clutch pack within the transmission makes an audible "clunk" when engaging into gear.

CAUTION

NEVER remove or loosen the four-bolt gear box lever cover from the transmission. The position of this plate and the actuating lever inside of the transmission has been finely adjusted at the factory to ensure equal throw distance of internal mechanisms. Loosening of this cover's capscrews voids the transmission's warranty.

Service

If any seal on the transmission shows signs of leaking, have the transmission looked at by a qualified Hurth Servicing Dealer. This problem, especially concerning the rear seal, is often contributed to an improper alignment of the transmission's coupling and the propeller shaft's coupling. Refer to the "Alignment of the Engine" section of this manual, page 13.

NOTE: A leaking rear seal can also be the result of a blocked vent hole in the head of the dipstick tube.

Recommended Propeller Size

Propeller Recommendations
(using HBW 150 transmission
1.88:1 reduction)

18 D x 10 P 2 - blade or 18 D x 8 P - 3 blade
Propeller should allow the engine to reach
its full rated RPM (3000 + 000 - 100) at full open
throttle while underway.

ENGINE TROUBLESHOOTING

Introduction

The tables which follow indicate troubleshooting procedures based upon certain problem indicators, the probable causes of the problems, and the recommendations to overcome these problems.

Note that the engine's control system (electrical system) is protected by a 20-Ampere manual reset circuit breaker located on the rear lifting bracket.

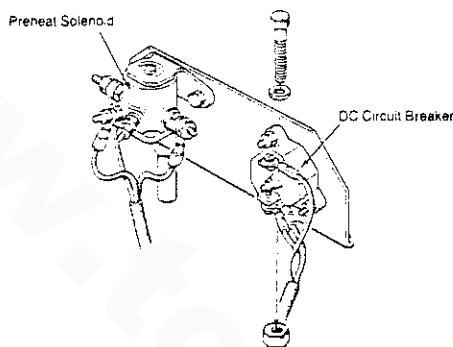

<u>Problem</u>	<u>Probable Cause</u>	<u>Verification/Remedy</u>
PREHEAT button is depressed: no panel indications.	Battery switch or Circuit Breaker is not ON.	Check the switch, Breaker and/or the battery connections.
	20-Amp circuit breaker has tripped.	Reset breaker; if the breaker trips again, check the preheat solenoid circuit and circuit for shorts.
START button is depressed: no starter engagement.	Must PREHEAT first.	PREHEAT button must be depressed to activate the START button.
	Connection to the solenoid is faulty.	Check the connection.
	Faulty START switch.	Check the switch with an ohmmeter.
	Faulty solenoid.	Check that 12 Volts is present at the solenoid connection on the starter.

<u>Problem</u>	<u>Probable Cause</u>	<u>Verification/Remedy</u>
START switch is depressed: no starter engagement. (continued)	Loose battery connection.	Check battery connections.
	Low battery voltage.	Check voltage present at the solenoid S terminal when the START button is depressed.
No ignition; engine cranks but does not start.	Shut-off lever.	Return shut-off lever to the RUN position.
	Faulty fueling system.	<ol style="list-style-type: none"> 1. Check for fuel to the engine. 2. Check for air in the fuel system. Bleed the fuel system. 3. Fuel lift pump is faulty. 4. Filters are clogged. (Replace filters and bleed the fuel system.)
Failure to stop.	Shut-off linkage is disconnected.	Stop engine by manually moving the RUN linkage to STOP. That failing, shut off fuel and air. Loosen high pressure lines to the injectors.
Engine stops.	Fuel starvation.	RPM fluctuation before stopping. Check for fuel blockage, clogged filters, or air in the fuel system.
	Fuel contamination.	Suddenly stops. Fuel contamination damaging the fuel injection pump. Clean the filter and bleed the fuel system. Check fuel delivery to the injectors.

<u>Problem</u>	<u>Probable Cause</u>	<u>Verification/Remedy</u>
Engine stops. (continued)	Transmission failure.	Check the fluid level in the transmission. Transmission seizure will stop the engine. Engine will not turn over by engaging the starter.
Battery is not charging.	Alternator drive	Check drive belt tension. Be sure the alternator turns freely. Check for loose connections. Check output with a voltmeter. Ensure that 12 Volts are present at the EXC connection. Check the alternator as described on page 39.
Battery runs down.	Circuit Breaker.	Observe if the gauges and panel lights are activated when the engine is not running. Test the Circuit Breaker.
	High resistance leak to the ground.	Check wiring. Insert a sensitive (0-.25 Amp) Amp meter in the battery lines. (Do not start the engine.) Remove connections and replace after the short is located.
	Low resistance leak to ground.	Check all wires for temperature rise to locate the fault.
	Alternator.	Disconnect the alternator at the output after a good battery charging. If the leakage stops, remove the alternator and bench test it. Repair or replace the unit.
	Preheat solenoid.	Test the preheat solenoid with a voltmeter on the lead to the thermostart device.

MAINTENANCE AND ADJUSTMENTS

Introduction

This section contains a scheduled preventive maintenance program and several adjustment procedures the owner/operator can perform without the benefit of sophisticated and expensive tools and instruments.

Preventive Maintenance

Perform the preventive maintenance in accordance with the schedules listed in the following paragraphs. Adherence to these schedules will ensure the equipment is maintained in the best possible condition and that it will perform to expectations. Those items marked by an asterisk (*) are recommended to be performed by an authorized dealer or distributor.

Daily (before each use)

1. Check the oil sump level. Maintain the oil level at or near upper level mark on dipstick.
2. Check the coolant level in the plastic recovery tank. Maintain this level at or above the level marked **ADD**.
3. Check the transmission's lubricant level, and add additional lubricant as needed.
4. Visually inspect the engine; check for loose belts, chafed or broken wires, loose brackets and fittings, damaged hoses, loose clamps, and other equipment not properly secured. This check should include the propeller shaft coupling to the transmission's output flange.
5. Visually inspect the sea water strainer.
6. Check the fuel supply. Fill tank(s) with a good grade of No. 2 diesel fuel, if required. Fuel additives are recommended to prevent algae growth.
7. Check the primary filter/water separator. Drain and service as required. (A primary filter/water separator is optional, but strongly recommended.)
8. Check the engine's gauges or lights for proper oil pressure, operating temperature, and starting battery charging voltage once the engine is operating.
9. Check each alternator's output gauge (if installed) for proper DC voltage.

Monthly

Check the condition of the zinc anode in the heat exchanger's sea water circuit. Clean or replace the anode, as required. Keep the area inside the heat exchanger clean of zinc anode debris. The rapid deterioration of the zinc anode may be an indication of electrolysis action caused by an electrical fault adjacent to the vessel, or from an electrical fault on the vessel.

Servicing After Initial 50 Hours of Operation

1. Change the engine's lubrication oil and oil filter.
2. Replace the fuel filter element as described on page 35. Clean and replace the filter element and bowl of the primary fuel filter/water separator, if one has been installed.
- *3. Torque the cylinder head nuts.
- *4. Adjust valve clearances.
5. Adjust the alternator, water pump and compressor drive belt tension, if required.
6. Lubricate the throttle, the RUN linkage cable, and the transmission's remote control cable.
7. Clean the air intake screen.
8. Adjust the engine's idle as needed.
9. Change the transmission's transmission fluid.

Servicing After Every 100 Hours of Operation

1. Change the engine's lubrication oil and oil filter.
2. Adjust the alternator and water pump drive belt tension, if required.
3. Check the transmission fluid or oil level.

Servicing After Every 250 Hours of Operation

1. Replace the on-engine fuel filter element and service the primary fuel filter/water separator as needed. Check the sea water pump's impeller.
2. Change the transmission's transmission fluid.

Servicing After Every 500 Hours of Operation

- *1. Torque the cylinder head nuts.
- *2. Adjust the valve clearances.
3. Drain, flush, and refill the fresh water cooling system.
- *4. Check the condition of the starter motor drive pinion; lubricate the pinion.
5. Check the sea water pump for any internal wear. Check the pump's cover, cam, and impeller. Replace those parts that are excessively worn.

6. Check the condition of all hoses and drive belts. Replace those that are badly worn.

NOTE: Items highlighted by an asterisk (*) should be performed by a competent mechanic.

Servicing After Every 800 Hours of Operation

*1. Remove and check fuel injectors.

Injector spray setting pressure:

2200 psi (155 kg/cm²)

Minimum working pressure:

2000 psi (140 kg/cm²)

Eliminate undesirable injection conditions including after-dripping. Refer to the illustration to the right.

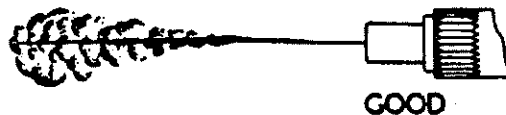

*2. Check the engine's compression pressure. Remove each glow plug and check each cylinder's compression pressure. The engine's cranking speed is between 250 and 300 rpm.

Standard	Minimum	
450 psi (31.6 kg/cm ²)	350 psi (24.6 kg/cm ²)	(Maximum difference between cylinders: 25 psi (1.7 kg/cm ²))

*3. Check the battery-charging alternator for proper operation.

*4. Check the tightness of bolts, nuts, and clamps.

Servicing After Every 1000 Hours of Operation

1. Remove, clean, and pressure test the primary heat exchanger. (A local automotive radiator shop should be able to clean and test the heat exchanger.)

NOTE: Operating in silty and/or tropical waters may require that a heat exchanger cleaning be performed more often than every 1000 hours.

*2. Check the fuel injection pump's timing.

VALVE CLEARANCE ADJUSTMENT

CAUTION

The cylinder head nuts must be retightened after the first 50-hours of break-in operation, and before adjusting the valves. Make sure the engine is cold when retightening the cylinder head nuts. Refer to the "TORQUE SPECIFICATION" section of this manual for proper tightening specifications, page 61.

If the engine needs to be timed, refer to the "TIMING ADJUSTMENT" section in the Technical Manual. Engine timing should be performed by a competent diesel mechanic.

Follow the procedure described below when tightening cylinder head nuts and when adjusting valves.

1. Loosen the hose clamp on the air breather pipe and remove the hose clamp and the air breather from the rocker cover. Remove the rocker cover bolts and remove the rocker cover.
2. Tighten the cylinder head nuts according to the sequence shown in the illustration shown below. Make sure the engine is cold when this is done. Loosen one head nut one-half turn and then tighten it to either 60 lb-ft, 8.3 kg-m, or to 81 N-m. Then proceed to the next head nut in the sequence numbering shown.

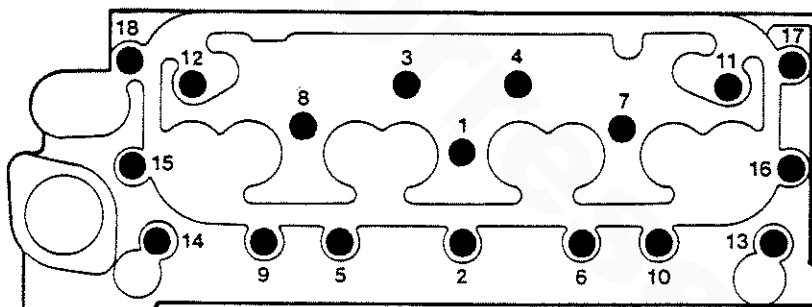

3. Torque the rocker shaft bracket securing nuts evenly between 12 to 15 lb-ft or 1.7 to 2 kg-m.
4. Adjust the valve clearances according to the procedures described in steps A-D. Adjust all valve clearances to 0.012 inches (0.30 mm) while the engine is cold.
 - A. While facing the front of the engine, turn the engine's crankshaft clockwise so that the No 1 cylinder's valves are in their "valve overlap" position; that is, the period between the opening of the inlet valve and the closing of the exhaust valve.
 - B. In this position, adjust the clearances of the No. 4 cylinder's valves. Turn the crankshaft as described in step A so that the valves of the No. 3 cylinder are in their overlap position, and then adjust the No. 2 cylinder's valves.
 - C. Turn the crankshaft again so that the valves of the No. 4 cylinder are in their overlap position, and adjust the No. 1 cylinder's valves.
 - D. Turn the crankshaft so that the valves of the No. 2 cylinder are in their overlap position, and adjust the No. 3 cylinder's valves.

TORQUE SPECIFICATIONS

The following torque tensions apply when the components are lightly oiled before assembly.

	Lb-ft	Kg-m	N-m
Cylinder Head Nuts	60	8.3	81
Connecting Rod Cap Bolts	42	5.8	57
* Main Bearing Cap Bolts	85	11.75	115
Flywheel Bolts	60	8.3	81
Idle Gear Hub Bolts	36	5.0	49
Crankshaft Pulley Bolt	150	20.7	203
Injector Securing Nuts	12	1.7	16
Fuel High Pressure Pipe Nuts	15	2.1	20
Alternator Pulley Nut	30	4.1	41
Thermostat Housing	10	1.38	13
Thermostat Insulating Adapter	10	1.38	13

* The tab and shim washers may be discarded where they were once used on earlier models, but the bolts must be tightened to the torque specification indicated.

All threads used, except those used to manufacture the basic engine, are of the Unified Series and American Pipe Series. The crankshaft and the pulley retaining bolts are threaded 5/8- inch Unified National Fine (U.N.F. 18 threads per inch).

GENERAL TORQUE TIGHTENING CHART

<u>kg-m</u>	<u>lb-ft.</u>
-------------	---------------

UNLESS OTHERWISE INDICATED

Grade 6T

6mm bolt/nut	0.7 - 1.0	5 - 7
8mm bolt/nut	1.6 - 2.3	12 - 17
10mm bolt/nut	3.2 - 4.7	23 - 24
12mm bolt/nut	5.6 - 8.2	41 - 59
14mm bolt/nut	7.7 - 10.5	56 - 76

Grade 8T and 8.8

6mm bolt/nut	.8 - 1.2	6 - 9
8mm bolt/nut	1.8 - 2.7	13 - 20
10mm bolt/nut	3.7 - 5.5	27 - 40
12mm bolt/nut	6.4 - 9.5	46 - 69
14mm bolt/nut	10.4 - 14.0	75 - 101

Grade 5 capscrew

1/4 UNC	1.2 - 1.5	9 - 11
1/4 UNF	1.5 - 1.8	11 - 13
5/16 UNC	2.5 - 2.8	18 - 20
5/16 UNF	2.9 - 3.2	21 - 23
3/8 UNC	3.7 - 4.6	28 - 33
3/8 UNF	4.1 - 4.8	30 - 35
7/16 UNC	6.1 - 6.8	44 - 49
7/16 UNF	6.9 - 7.6	50 - 55
1/2 UNC	9.4 - 10.1	68 - 73
1/2 UNF	10.1 - 11.1	73 - 80

LAY-UP AND RECOMMISSIONING

General

Many owners rely on their boatyards to prepare their craft, including engines and generators, for lay-up during the off-season or for long periods of inactivity. Others prefer to accomplish lay-up preparation themselves.

The procedures which follow will allow you to perform your own lay-up and recommissioning, or to use as a check list if others do the procedures.

These procedures should afford your engine protection during a lay-up and also help familiarize you with the maintenance needs of your engine.

If you have any questions regarding lay-up procedures, call your local servicing dealer; he will be more than willing to provide assistance.

Propeller Coupling

The transmission and propeller half couplings should always be opened up and the bolts removed whenever the boat is hauled out of the water or moved from land to water, and during storage in a cradle. The flexibility of the boat often puts a severe strain on the propeller shaft or coupling, or both, while the boat is taken out or put in the water. In some cases, the shaft has actually been bent by these strains. This does not apply to small boats that are hauled out of the water when not in use, unless they have been dry for a considerable period of time.

Fresh Water Cooling System

A 50-50 solution of antifreeze and fresh water is recommended for use in the fresh water cooling system at all times. This solution may require a higher concentration of antifreeze, depending on the area's winter climate. Check the solution to ensure that the antifreeze protection is adequate.

Should more antifreeze be needed, drain an appropriate amount from the engine block and add a more concentrated mixture. Operate the engine to ensure a complete circulation and mixture of the antifreeze concentration throughout the cooling system. Now recheck the antifreeze solution's strength.

Lubrication System

With the engine warm, drain all the lubricating oil from the oil sump. Remove and replace the oil filter. (Place some paper towels and a plastic bag around the filter to catch the oil during its removal.)

When installing the new oil filter, be sure to apply a small amount of oil on the rubber sealing gasket at the base of the filter. Fill the sump with the correct amount of oil for your engine. (Refer to the "SYSTEM SPECIFICATIONS" section of this manual, page 8.) Use an oil with an API specification of CC or CD. Run the engine and check for proper oil pressure and ensure that there are no leaks.

CAUTION

Do not leave the engine's old lubricating oil in the sump over the lay-up period. Lubricating oil and combustion deposits combine to produce harmful chemicals which can reduce the life of your engine's internal parts.

Fuel System

Top off your fuel tanks with No. 2 diesel fuel. Fuel additives should be added at this time to control algae and condition the fuel. Care should be taken that the additives used are compatible with the primary filter/water separator used in the system. Change the element in your primary fuel filter/water separator, if the fuel system contains one, and clean the separator sediment bowl.

Change the fuel filter elements on the engine and bleed the fuel system, as needed. Start the engine and allow it to run for 5 - 10 minutes to ensure that no air is left in the fuel system. Check for any leaks that may have been created in the fuel system during this servicing, correcting them as needed.

Sea Water Circuit

Close the through-hull sea cock. Remove the sea water intake hose from the sea cock. Place the end of this hose into a 5-gallon bucket of clean fresh water. Before starting the engine, check the zinc anode found in the primary heat exchanger on the engine and clean or replace it as required. Clean the sea strainer, if one is installed in the inside of the hull.

Start the engine and allow the sea water pump to draw fresh water through the system. When the bucket is empty, stop the engine and refill the bucket with an antifreeze solution slightly stronger than needed for winter freeze protection in your area.

Start the engine and allow all of this mixture to be drawn through the sea water system. Once the bucket is empty, stop the engine. This antifreeze mixture should protect the sea water circuit from freezing during the winter lay-up, as well as providing corrosion protection.

Remove the impeller from your sea water pump (some antifreeze mixture will accompany it, so catch it in a bucket). Examine the impeller. Acquire a replacement, if needed, along with a cover gasket. Do not replace the impeller (into the pump) until recommissioning, but replace the cover and gasket.

Intake Manifold and Through-Hull Exhaust

Place a clean cloth, lightly soaked in lubricating oil, in the opening of the intake manifold to block the opening. Do not shove the cloth out of sight. (If it is not visible at recommissioning, and an attempt is made to start the engine, you may need the assistance of a servicing dealer.) Make a note to remove the cloth prior to start-up. The through-hull exhaust part can be blocked in the same manner.

Starter Motor

Lubrication and cleaning of the starter drive pinion is advisable, if access to the starter permits its easy removal. Ensure that the battery connections are shut off before attempting to remove the starter. Take care in properly replacing any electrical connections removed from the starter.

Cylinder Lubrication

It is not necessary to remove the fuel injectors from the cylinder head to squirt light lubricating oil into the cylinders for the few months of normal lay-up. However, if you anticipate a longer lay-up period (12 months or more), we recommended that this procedure be performed. The light oil in the cylinders will prevent the pistons rings from sticking to the cylinder walls. Make sure you have replacements for the injector and return line sealing washers.

Spares

Lay-up time provides a good opportunity to inspect your Westerbeke engine to see if external items such as drive belts or coolant hoses need replacement. Check your basic spares kit and order items not on hand, or replace those items used during the lay-up, such as filters and zinc anodes.

Batteries

If batteries are to be left on board during the lay-up period, make sure they are fully charged, and that they will remain that way, to prevent them from freezing. If there exists any doubt that the batteries will not remain fully charged or that they will be subjected to severe environmental conditions, remove the batteries and store them in a warmer, more compatible environment.

Recommissioning

The recommissioning of your Westerbeke engine after a seasonal lay-up generally follows the same procedures as those presented in the "PREPARATIONS FOR STARTING" section, page 22, regarding preparation for starting and normal starts. However, some of the lay-up procedures will need to be counteracted before starting the engine.

1. Remove the oil-soaked cloths from the intake manifold and from the through-hull exhaust port.
2. Remove the sea water pump cover and gasket and discard the old gasket. Install the sea water pump impeller removed during lay-up (or a replacement, if required). Install the sea water pump cover with a new cover gasket.

WARNING

Wear rubber gloves, a rubber apron, and eye protection when servicing batteries.

Lead acid batteries emit hydrogen, a highly-explosive gas, which can be ignited by electrical arcing or a lighted cigarette, cigar, or pipe. Do not smoke or allow an open flame near the battery while someone is servicing it. Shut off all electrical equipment in the vicinity to prevent electrical arcing during servicing.

3. Reinstall the batteries that were removed during the lay-up, and reconnect the battery cables, making sure the terminals are clean and that the connections are tight. Check to ensure that the batteries are fully-charged.

4. Check the condition of the zinc anode in the sea water circuit and clean or replace the anode as needed. Note that it is not necessary to flush the antifreeze/fresh water solution from the sea water coolant system. When the engine is put into operation, the system will self-flush in a short period of time with no adverse affects.
5. Start the engine in accordance with procedures in the "PREPARATIONS FOR STARTING" section of this manual, page 22.

www.torresen.com

INDEX

A

ADJUSTMENTS, MAINTENANCE AND 57
 ADJUSTMENT, VALVE CLEARANCE..... 60
 Alignment (The HBW 150 Transmission) 51
 Alignment of the Engine (Installation Checks)..... 13
 Alternator and Water Pump Drive Belt Tension 46
 ANTIFREEZE CONCENTRATION DATA..... 43
 Assembly, Oil Cooler (Illustration) 49
 Automatic Alarm System (Installation Checks)..... 18

B

Back-Pressure, Exhaust (Installation Checks) 15
 Batteries (Lay-up and Recommissioning) 65
 Battery Specification 37
 Belt Drive System 36
 Belt Tension, Alternator and Water Pump Drive 46
 Bleeding the Fuel System, Priming and 32
 Bolts, Engine (Installation Checks)..... 12
 Break-In Procedures, Engine..... 28

C

CAUTIONS

ENGINE SHIPPED WITHOUT OIL 10
 LIFTING SLINGS 11
 THROUGH-HULL FITTINGS 19
 PROLONGED CRANKING 26
 SHUTTING OFF THE ENGINE WITHOUT THE CIRCUIT BREAKER..... 28
 PROLONGED CRANKING 32
 BATTERY CHARGING CIRCUIT..... 37
 QUICK-CHARGING THE BATTERY..... 37
 TESTING THE ALTERNATOR 38
 EXCESSIVE BELT TENSION 46
 GEAR BOX LEVER COVER 52
 TIGHTENING CYLINDER HEAD NUTS..... 60
 LEAVING OLD OIL IN THE SUMP 64

Change, Engine Oil (to include filter) 48
 Charging Voltage Test 39
 CHART, GENERAL TORQUE TIGHTENING 62
 Circuit, Fresh Water 42
 Circuit Sea Water 45
 Cold Conditions, Starting Under 30
 CONTENTS, TABLE OF 3
 Control Circuit, Engine 12-Volt DC..... 37
 Control Circuit Wiring Diagram # 37248, DC 40 and 41

Controls (The HBW 150 Transmission).....	52
Connecting Pressure Sensing Devices to Oil Galleries (Installation Checks).....	18
Cooler, Oil, Assembly (Illustration).....	49
Cooling System (Installation Checks).....	18
COOLING SYSTEM	42
Coupling, Propeller (Lay-up and Recommissioning)	63
Coupling, Propeller Shaft (Installation Checks).....	13
Cylinder Lubrication (Lay-up and Recommissioning).....	65

D

DC Control Circuit, Engine, 12-Volt.....	37
DC Control Circuit Wiring Diagram # 37248.....	40 and 41
DESCRIPTION OF INSTRUMENT PANEL.....	24
Diesel Engine, Understanding the.....	4
Diesel Fuel.....	31
DISCLAIMER, PRODUCT SOFTWARE	1
Drain Hose, Oil (Installation Checks).....	17
Drive System, Belt.....	36

E

Electrical System (Installation Checks).....	21
ELECTRICAL SYSTEM	37
Engine 12-Volt DC Control Circuit.....	37
Engine, Alignment of the (Installation Checks).....	13
Engine Bolts (Installation Checks)	12
Engine Break-In Procedures	28
Engine, Diesel, Understanding the.....	4
Engine, Foundation for the (Installation Checks).....	12
Engine Oil.....	47
Engine Oil Change (to include filter).....	48
Engine Oil Viscosity (SAE Number).....	47
ENGINE TROUBLESHOOTING	54
Equipment, Inspection of	2
Exhaust Back-Pressure (Installation Checks).....	16
Exhaust System (Installation Checks)	15
Exhaust System Failures (Installation Checks)	17

F

Failures, Exhaust System (Installation Checks).....	17
FORWARD.....	2
Foundation for the Engine (Installation Checks).....	12
Fresh Water Circuit.....	42
Fresh Water Cooling System (Lay-up and Recommissioning).....	63
Fuel Diesel.....	31
Fuel Filters.....	31
Fuel Filter Elements, Replacing the.....	35

Fuel Injection Pump	36
Fuel System (Installation Checks)	20
FUEL SYSTEM	31
Fuel System (Lay-up and Recommissioning)	64
Fuel System, Priming and Bleeding	32

G

GENERAL	4
GENERAL SPECIFICATIONS	7
GENERAL TORQUE TIGHTENING CHART	62

H

HBW 150 TRANSMISSION, THE	50
Hose, Oil Drain (Installation Checks)	17

I

INDEX	67
Injection Pump, Fuel	36
Inspection of Equipment	2
INSTALLATION CHECKS	10
INSTRUMENT PANEL, DESCRIPTION OF	24
Intake Manifold and Through-Hull Exhaust (Lay-up and Recommissioning)	64

L

LAY-UP AND RECOMMISSIONING	63
Lifting, Rigging and (Installation Checks)	11
LIST, PARTS	99
Location (Installation Checks)	10
Lubrication (The HBW 150 Transmission)	50
Lubrication, Cylinder (Lay-up and Recommissioning)	65
LUBRICATION SYSTEM	47
Lubrication System (Lay-up and Recommissioning)	63

M

MAINTENANCE AND ADJUSTMENTS	57
Motor, Starter (Lay-up and Recommissioning)	64

N

Normal Conditions, Starting Under	29
-----------------------------------------	----

O

Oil Change, Engine (to include filter)48
 Oil Cooler Assembly (Illustration).....49
 Oil Drain Hose (Installation Checks).....17
 Oil, Engine.....47
 Oil, Engine, Viscosity (SAE Number).....47
 Oil Galleries, Connecting Pressure Sensing Devises to (Installation Checks).....18
 Oil Pressure.....47
 Ordering Parts.....4

P

PANEL, DESCRIPTION OF INSTRUMENT24
 PARTS LIST.....99
 Parts, Ordering.....4
 Priming and Bleeding the Fuel System.....32
 PRECAUTIONS, SAFETYInside front cover
 PREPARATION FOR STARTING22
 Pressure, Oil.....47
 Pressure Sensing Devices to Oil Galleries, Connecting (Installation Checks).....18
 Procedures, Engine Break-In28
 PROCEDURE, STARTING26
 PROCEDURES, STOPPING28
 PRODUCT SOFTWARE DISCLAIMER1
 Propeller (Installation Checks)13
 Propeller Coupling (Lay-up and Recommissioning)63
 Propeller Shaft Coupling (Installation Checks).....13
 Propeller Size, Recommended (The HBW 150 Transmission)53
 Pump, Fuel Injection.....36
 Pump, Sea Water.....45

R

Recommended Propeller Size (The HBW 150 Transmission)53
 Recommissioning (Lay-up and Recommissioning)65
 Replacing the Fuel Filter Elements.....35
 Rigging and Lifting (Installation Checks)11

S

SAFETY PRECAUTIONSInside front cover
 Sea Water Circuit45
 Sea Water Circuit (Lay-up and Recommissioning)64
 Sea Water Intake System (Installation Checks).....20
 Sea Water Pump.....45
 Service (The HBW 150 Transmission)53
 Shaft Coupling, Propeller (Installation Checks).....13
 Shifting (The HBW 150 Transmission)52

Shifting, Transmission.....	27
SOFTWARE DISCLAIMER, PRODUCT.....	1
Spares (Lay-up and Recommissioning).....	65
SPECIFICATION(S)	
GENERAL.....	7
SYSTEM.....	8
Battery.....	37
TORQUE.....	61
STOPPING PROCEDURES.....	28
Starter Motor (Lay-up and Recommissioning).....	64
STARTING, PREPARATION FOR.....	22
STARTING PROCEDURE.....	26
Starting Under Cold Conditions.....	30
Starting Under Normal Conditions.....	29
SYSTEM	
Exhaust, (Installation Checks).....	15
Failures, Exhaust (Installation Checks).....	17
Automatic Alarm, (Installation Checks).....	18
Cooling, (Installation Checks).....	18
Fuel, (Installation Checks).....	20
Electrical, (Installation Checks).....	21
Starting,.....	23
FUEL,.....	31
Belt Drive,.....	36
ELECTRICAL,.....	37
COOLING,.....	42

T

TABLE OF CONTENTS.....	3
Tension, Alternator and Water Pump Drive Belt Tension.....	46
Test, Charging Voltage.....	39
THE HBW 150 TRANSMISSION.....	50
Thermostat.....	45
Through-Hull Exhaust, Intake Manifold and (Lay-up and Recommissioning).....	64
TORQUE SPECIFICATIONS.....	61
TORQUE TIGHTENING CHART, GENERAL.....	62
Transmission Shifting.....	27
TRANSMISSION, THE HBW 150.....	50
TROUBLESHOOTING, ENGINE.....	54

U

Under Cold Conditions, Starting.....	30
Under Normal Conditions, Starting.....	29
Understanding the Diesel Engine.....	4

V

VALVE CLEARANCE ADJUSTMENT60
Ventilation (Installation Checks).....21
Viscosity, Engine Oil (SEA Number)47
Voltage Test, Charging39

W

WARNINGS

DIESEL FUMES 17
SMOKING NEAR BATTERIES..... 21
SERVICING BATTERIES..... 21
ADJUSTING DRIVE BELT TENSION..... 46
BATTERY ACID..... 65

Water Circuit, Fresh42
Water Circuit, Sea45
Water Intake System, Sea (Installation Checks).....20
Water Pump, Sea
Wiring Diagram #37248, DC Control Circuit 40 and 41

PARTS LIST

Cylinder Block	100
Cylinder Head and Valves.....	102
Crankshaft and Pistons.....	104
Timing System and Camshaft.....	106
Rocker Shaft and Cover.....	108
Intake Manifold	110
Lube Oil Sump and Oil Pump.....	112
Cooling System.....	114
Fresh Water Pump and Water Injected Exhaust Elbow	118
Sea Water Pump	120
Fuel System.....	122
Back End - Transmission - Mounting System	126
HBW Transmission Shifting Bracket.....	130
Standard Alternator - Oil manifold	132
Electrical Harness	134
Instrument Panel	136
Alternators and Compressor Mounting System	138

WESTERBEKE 40A - CYLINDER BLOCK

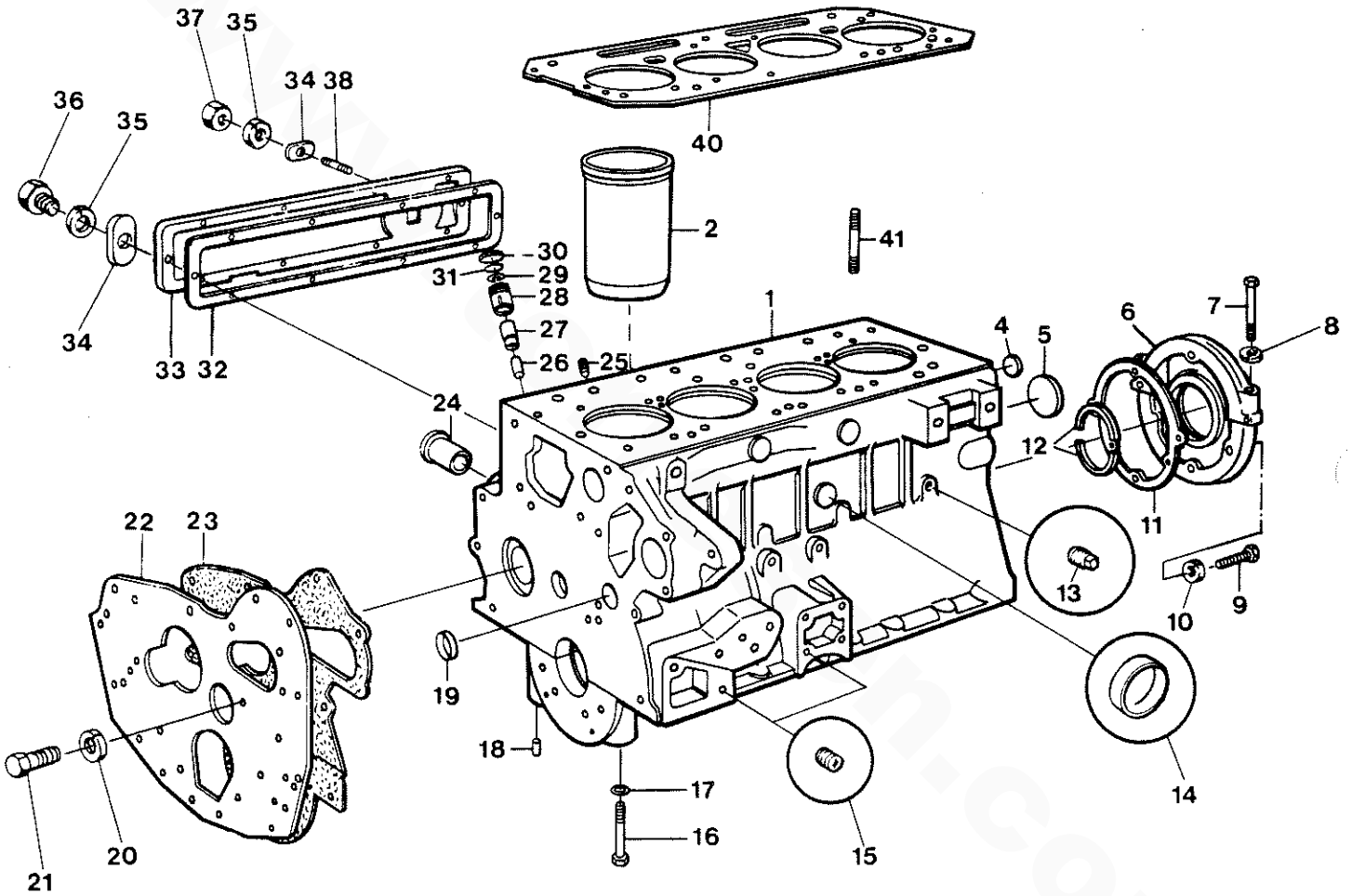

WESTERBEKE 40A - CYLINDER BLOCK

REF	PN	NAME	REMARKS	QUAN
1-1	030870	ENGINE	BLOCK & HEAD ASSEMBLY	1
1-2	011487	ENGINE	ASSEMBLY	1
2	019990	LINER		4
4	012452	PLUG		1
5	012458	PLUG	REAR CAMSHAFT CHAMBER	1
6	012334	HOUSING		1
7	012356	BOLT		2
8	031758	LOCKWASHER	5/16	2
9	012475	CAPSCREW	5/16NF X 1-3/8 FULLY THREADED	6
10	031758	LOCKWASHER	5/16	6
11	012661	GASKET		1
12	011993	SEAL		2
13	013341	PLUG	BLOCK DRAIN	1
14	012454	PLUG	EXPANSION	5
15	019992	PLUG	OIL GALLERY	2
16	012469	BOLT	MAIN BEARING CAP	6
17	012623	SHIM		6
18	012380	DOWEL		6
19	012456	PLUG	EXPANSION FRONT & REAR	2
20	031758	LOCKWASHER	5/16	4
21	012473	CAPSCREW	5/16NF X 3/4	4
22	012656	PLATE	TIMING COVER MOUNT	1
23	012406	GASKET		1
24	012371	CONNECTOR	FRESH WATER HOSE	1
25	012464	PLUG	ALTERNATE DIPSTICK POSITION	1
26	012484	SHAFT	TACHOMETER DRIVE	1
27	014686	BEARING	TACHOMETER DRIVE	1
28	012485	SLEEVE	TACHOMETER DRIVE	1
29	012363	SNAPRING	TACHOMETER DRIVE	1
30-1	012620	CAP	PLASTIC	1
30-2	019994	CAP	METAL	1
31	012619	WASHER	TACHOMETER DRIVE	1
32	012666	GASKET	SIDE COVER TO BLOCK	1
33	020029	COVER	SIDE	1
34	012652	STIFFENER		10
35	031758	LOCKWASHER	5/16	10
36	012473	CAPSCREW	5/16NF X 3/4	2
37	031760	NUT	5/16NF	8
38	012498	STUD		8
40	020020	GASKET	HEAD	1
41	019965	STUD		18
42	013341	PLUG	BLOCK DRAIN	1

WESTERBEKE 40A - CYLINDER HEAD AND VALVES

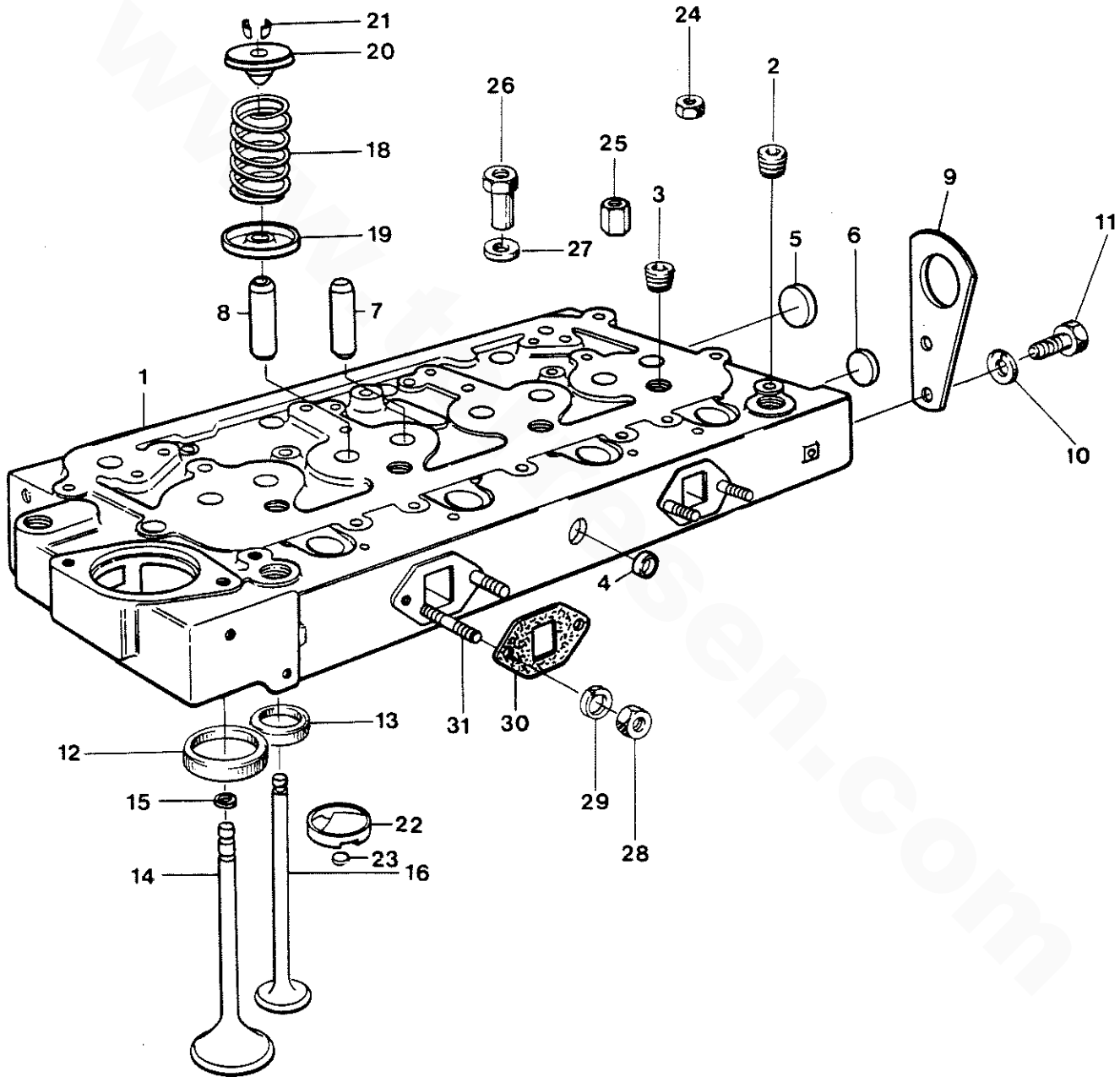

WESTERBEKE 40A - CYLINDER HEAD AND VALVES

REF	PN	NAME	REMARKS	QUAN
1	019939	HEAD	ASSEMBLY	1
2	019979	PLUG	TOP	3
3	023143	PLUG	TOP	4
4	012452	PLUG	SIDE	1
5	012454	PLUG	REAR	1
6	012455	PLUG	REAR	1
7	012629	GUIDE	INTAKE VALVE	4
8	012628	GUIDE	EXHAUST VALVE	4
9	012546	EYE	REAR LIFTING	1
10	031764	LOCKWASHER	3/8	2
11	031628	CAPSCREW	3/8NF X 3/4	2
12	019999	SEAT	INTAKE VALVE	4
13	019997	SEAT	EXHAUST VALVE	4
14	012509	VALVE	INTAKE	4
15	012635	DEFLECTOR	INTAKE VALVE	8
16	012510	VALVE	EXHAUST	4
18	019960	SPRING	VALVE	8
19	012536	SEAT	VALVE SPRING-LOWER	8
20	012360	SEAT	VALVE SPRING-UPPER	8
21	012378	COTTER	VALVE-PAIR	8
22	012682	INSERT	COMBUSTION CHAMBER	4
23	012542	WASHER	WELSH	4
25	014445	NUT	HEAD-SHORT	12
26	020005	NUT	HEAD-LONG	6
27	014443	WASHER	HEAD STUDS	18
28	031760	NUT	5/16NF	4
29-1	031758	LOCKWASHER	5/16	4
29-2	031759	WASHER	FLAT 5/16	4
30	011653	GASKET	HEAD TO EXHAUST MANIFOLD	2
31	014810	STUD	EXHAUST MANIFOLD TO HEAD	4

WESTERBEKE 40A - CRANKSHAFT AND PISTONS

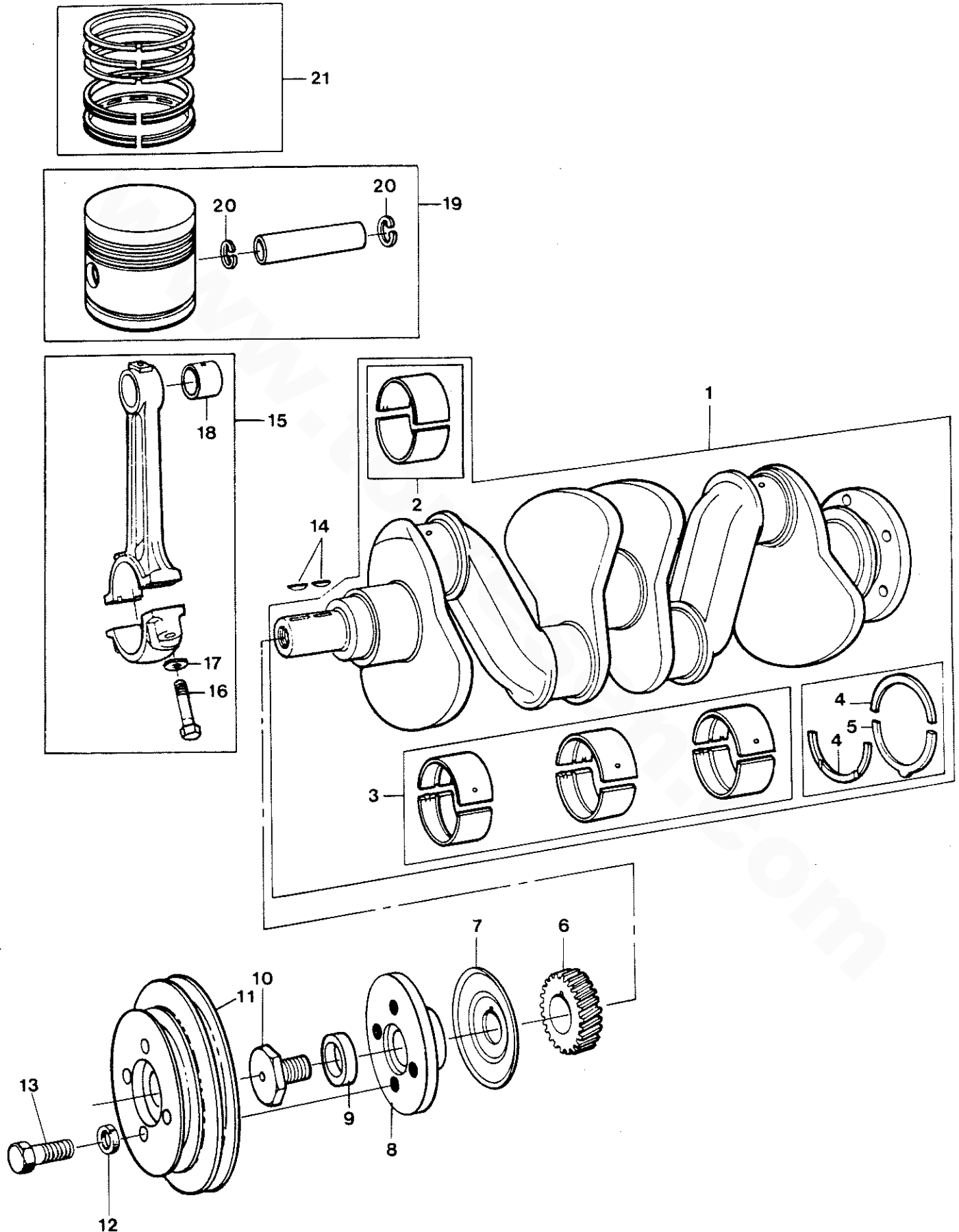

WESTERBEKE 40A - CRANKSHAFT AND PISTONS

REF	PN	NAME	REMARKS	QUAN
1	023105	CRANKSHAFT	ASSEMBLY	1
2-1	012343	BEARING	SET-CONNECTING ROD STD	1
2-2	012414	BEARING	SET-CONNECTING ROD 0.010	1
2-3	012423	BEARING	SET-CONNECTING ROD 0.020	1
2-4	012519	BEARING	SET-CONNECTING ROD 0.030	1
3-1	012342	BEARING	SET-MAIN STD	1
3-2	012349	BEARING	SET-MAIN 0.010	1
3-3	012370	BEARING	SET-MAIN 0.020	1
3-4	012373	BEARING	SET-MAIN 0.030	1
4-1	014707	WASHER	THRUST STD	2
4-2	019969	WASHER	THRUST 0.007	AR
5-1	012537	WASHER	THRUST STD	1
5-2	019968	WASHER	THRUST 0.007	AR
6	014719	GEAR	CRANKSHAFT	1
7	012383	SLINGER		1
8	012633	ADAPTER	CRANKSHAFT PULLEY	1
9	011857	WASHER	CRANKSHAFT PULLEY	1
10	012613	BOLT	PULLEY RETAINING	1
11-1	012595	PULLEY	CRANKSHAFT STD	1
11-2	023526	PULLEY	OPTIONAL 6 IN 6 GR	1
11-3	016356	PULLEY	OPTIONAL 5 IN 4 GR & 4 IN 2 GR	1
11-4	012038	PULLEY	OPTIONAL 7 IN 2 GR	1
11-5	036428	PULLEY	OPTIONAL 6 IN 4 GR	1
11-6	012020	PULLEY	ACCESSORY 5 IN 2 GR	1
11-7	012039	PULLEY	ACCESSORY 6 IN 2 GR	1
12	031752	LOCKWASHER	1/4	4
13		CAPSCREW	1/4NF X 1-1/8 STD PULLEY	4
14	012408	KEY		2
15	019935	ROD	CONNECTING ASSEMBLY	4
16	012348	BOLT	CONNECTING ROD	8
17	012622	WASHER	FLAT	8
18	019986	BUSHING	CONNECTING ROD	4
19	019938	PISTON	ASSEMBLY	4
20	019984	SNAPRING	PISTON PIN	8
21	019937	RING SET	STD	4

WESTERBEKE 40A - TIMING SYSTEM AND CAMSHAFT

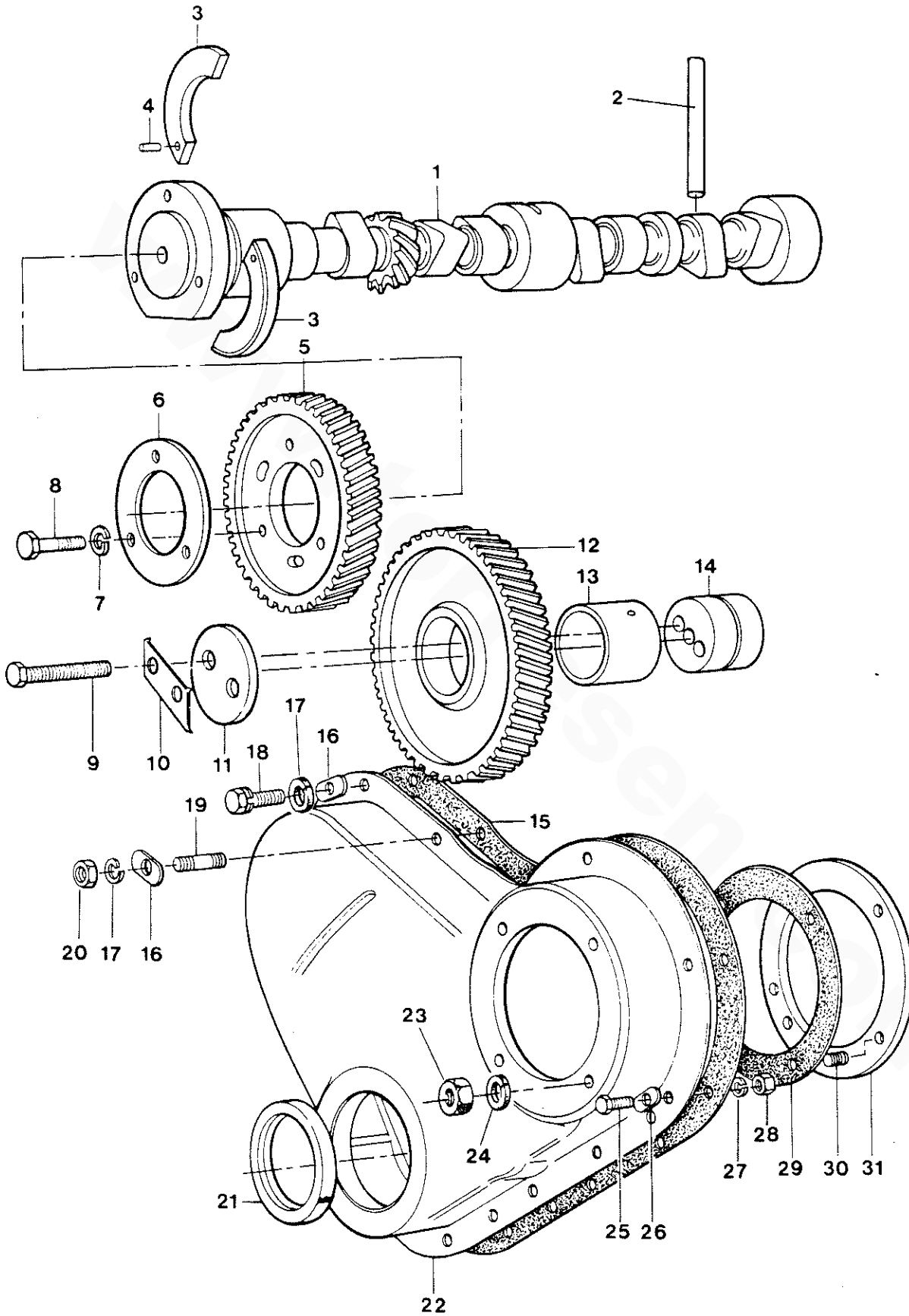

WESTERBEKE 40A - TIMING SYSTEM AND CAMSHAFT

REF	PN	NAME	REMARKS	QUAN
1	012605	CAMSHAFT		1
2	012460	PUSHROD	FUEL LIFT PUMP	1
3	012654	PLATE	CAMSHAFT THRUST	2
4	012440	DOWEL		1
5	012597	GEAR	CAMSHAFT	1
6	012625	PLATE		1
7	031758	LOCKWASHER	5/16	3
8	012474	CAPSCREW	5/16NF X 7/8	3
9	012481	CAPSCREW	IDLER GEAR	2
10	012541	TABWASHER		1
11	012551	PLATE	IDLER GEAR	1
12	012689	GEAR	IDLER WITH BUSHING	1
13	014685	BUSHING	IDLER GEAR	1
14	012388	HUB	IDLER GEAR	1
15	012658	GASKET	TIMING COVER	1
16	012652	STIFFENER		8
17	031758	LOCKWASHER	5/16	10
18	012474	CAPSCREW	5/16NF X 7/8	9
19	012493	STUD		1
20	031760	NUT	5/16NF	1
21	012466	SEAL	TIMING COVER	1
22	012678	COVER	TIMING	1
23	031760	NUT	5/16NF	4
24	031758	LOCKWASHER	5/16	4
25	012471	CAPSCREW	1/4NF X 5/8	4
26	013536	STIFFENER		3
27	031752	LOCKWASHER	1/4	4
28	031754	NUT	1/4NF	4
29	012636	GASKET	PLATE TO TIMING COVER	1
30	012500	STUD	SEA WATER PUMP MOUNT	4
31	012626	PLATE	SUPPORT SEA WATER PUMP	1

WESTERBEKE 40A - ROCKER SHAFT AND COVER

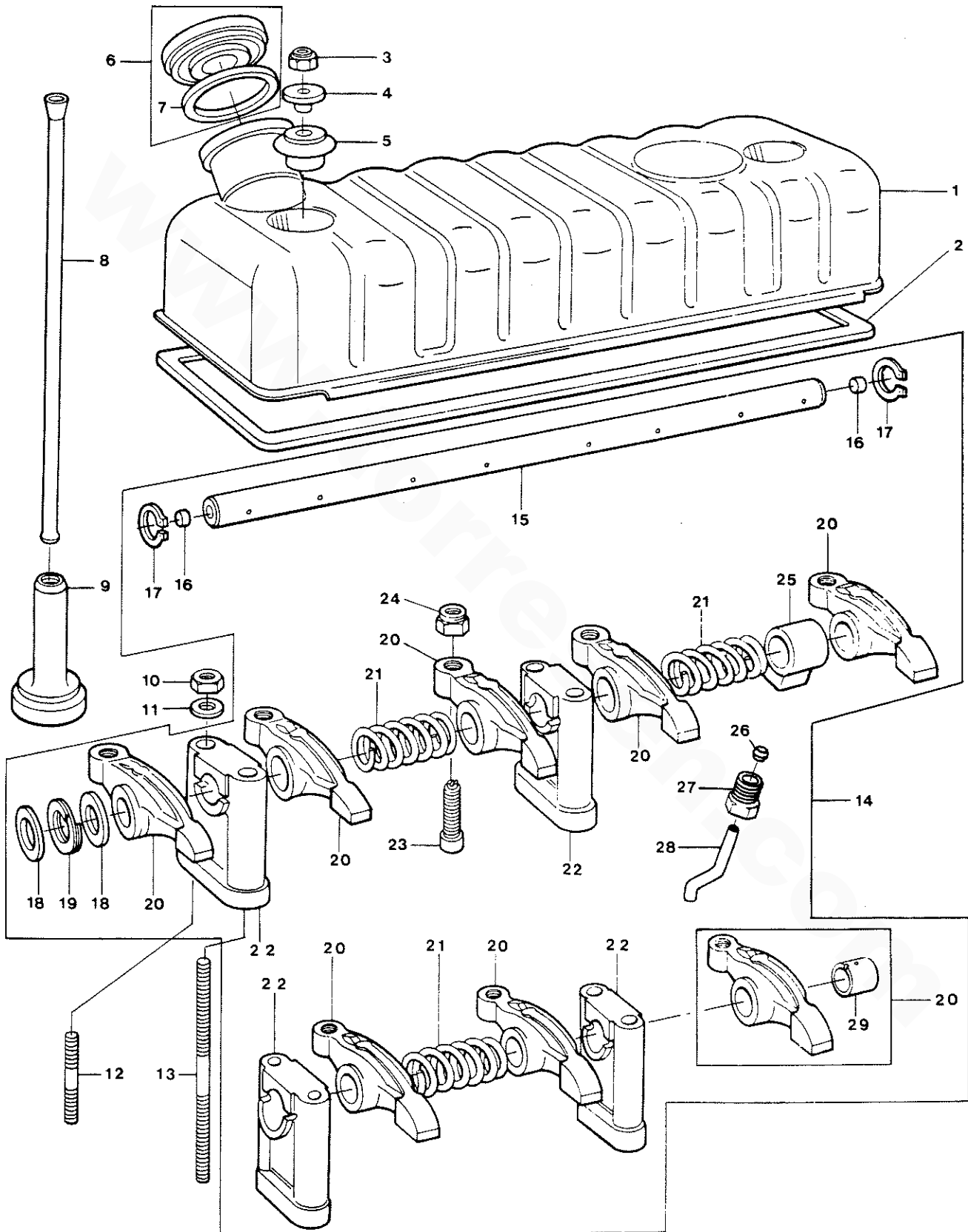

WESTERBEKE 40A - ROCKER SHAFT AND COVER

REF	PN	NAME	REMARKS	QUAN
1	012681	COVER	ROCKER	1
2	012404	GASKET	ROCKER COVER	1
3	012429	NUT		2
4	012535	WASHER		2
5	012467	SEAL		2
6	012567	CAP	OIL FILLER INCL GASKET	1
7	032184	GASKET	OIL FILLER CAP	1
8	012607	PUSHROD		8
9	012606	TAPPET		8
10	012434	NUT	LOCKING	8
11	031759	WASHER	FLAT 5/16	8
12	012499	STUD	SHORT 3-5/8	6
13	012494	STUD	LONG 4-1/2	2
14	012336	SHAFT	COMPLETE ASSEMBLY	1
15	012335	SHAFT	ROCKER WITH PLUGS	1
16	012446	PLUG		2
17	012362	SNAPRING		2
18	012525	WASHER		4
19	012539	WASHER		2
20	012333	ROCKER	WITH BUSHING	8
21	012488	SPRING		3
22	012358	BRACKET		4
23	012462	SCREW	ROCKER ADJUSTING	8
24	012433	NUT		8
25	012372	CONNECTOR	OIL FEED TO ROCKER SHAFT	1
26	012413	FERRULE		2
27	012419	NUT		2
28	012637	LINE	HEAD TO ROCKER SHAFT	1
29	012331	BUSHING	ROCKER	8

WESTERBEKE 40A - INTAKE MANIFOLD

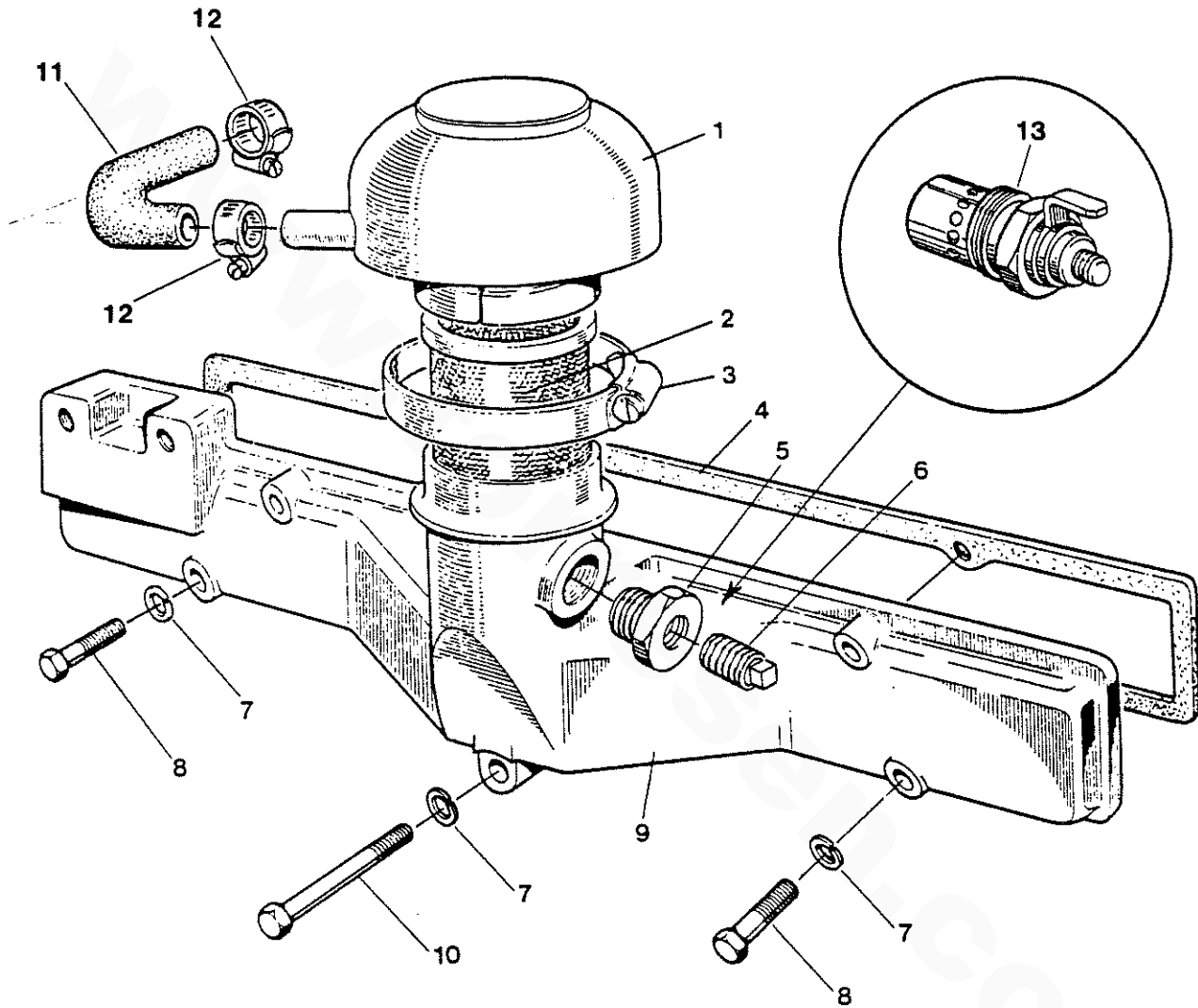

WESTERBEKE 40A - INTAKE MANIFOLD

REF	PN	NAME	REMARKS	QUAN
1	012683	COVER	AIR INTAKE	1
2	012556	FILTER	AIR INTAKE	1
3	011411	CLAMP	HOSE 32	1
4	020021	GASKET	INTAKE MANIFOLD TO HEAD	1
5-1	022841	ADAPTER	MANIFOLD TO 7/8UNF	1
5-2	024881	PLUG	7/8UNF-WHEN HEATER NOT INSTALLED	1
5-3	013392	BUSHING	7/8UNF TO 1/8NPT	1
6-1	011688	START AID	ETHER TYPE	1
6-2	011615	PLUG	1/8NPT	1
7	031758	LOCKWASHER	5/16	7
8-1	031582	CAPSCREW	5/16NF X 1-1/2	4
8-2	031581	CAPSCREW	5/16NF X 1-1/4	2
9-1	012688	MANIFOLD	AIR INTAKE	1
9-2	019382	MANIFOLD	AIR INTAKE-ACCEPTS LUB-CEL	1
10	031588	CAPSCREW	5/16NF X 3	1
11	012639	ELBOW	BREATHER HOSE	1
12	011341	CLAMP	HOSE 8	2
13	011530	HEATER	MANIFOLD 12 VDC	1

WESTERBEKE 40A - LUBE OIL SUMP AND OIL PUMP

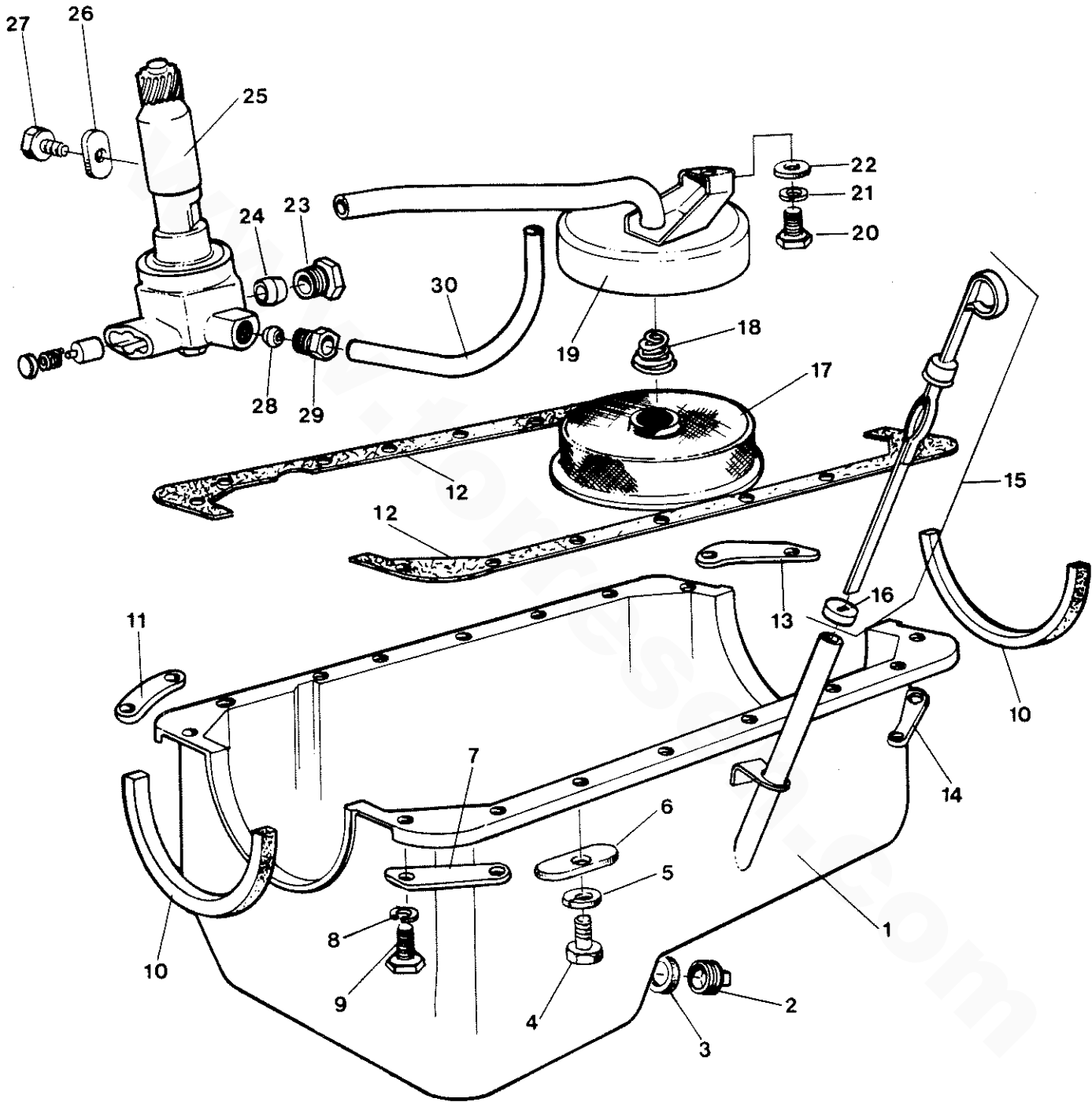

WESTERBEKE 40A - LUBE OIL SUMP AND OIL PUMP

REF	PN	NAME	REMARKS	QUAN
1	035304	SUMP	OIL	1
2	035305	PLUG	SUMP DRAIN 3/4-16UNF	1
3	035306	WASHER	SUMP DRAIN PLUG	1
4	012473	CAPSCREW	5/16NF X 3/4	8
5	031758	LOCKWASHER	5/16	8
6	012652	STIFFENER	SUMP SIDE	8
7	012547	STIFFENER		1
8	031758	LOCKWASHER	5/16	8
9	012474	CAPSCREW	5/16NF X 7/8	8
10	012407	GASKET		2
11	012550	STIFFENER		1
12	012659	GASKET SET	SUMP-LEFT AND RIGHT	1
13	012549	STIFFENER		1
14	012548	STIFFENER		1
15	012612	DIPSTICK		1
16	014816	WASHER		1
17	012686	STRAINER	OIL PICKUP	1
18	012491	SPRING	OIL PICKUP	1
19	012651	LINE	OIL STRAINER TO PUMP	1
20	012473	CAPSCREW	5/16NF X 3/4	1
21	031758	LOCKWASHER	5/16	1
22	031759	WASHER	FLAT 5/16	1
23	020006	NUT	SUCTION LINE	1
24	019950	FERRULE	SUCTION LINE	1
25	012692	PUMP	LUBE OIL	1
26	020017	TABWASHER	OIL PUMP RETAINING CAPSCREW	1
27		CAPSCREW	5/16NF X 1-1/16	1
28	019951	FERRULE	LUBE OIL DELIVERY LINE	2
29	019952	NUT	LUBE OIL DELIVERY LINE	2
30	012442	LINE	LUBE OIL DELIVERY TO BLOCK	1
31	036088	WASHER	SUMP DRAIN HOSE TO SUMP	1
32	036392	HOSE	SUMP DRAIN	1
33	036087	TABWASHER	SUMP DRAIN	1
34	036085	BOLT	BANJO-SUMP DRAIN	1
35	024922	BRACKET	SUMP DRAIN HOSE	1
36	024905	CAP	SUMP DRAIN HOSE	1

WESTERBEKE 40A - COOLING SYSTEM

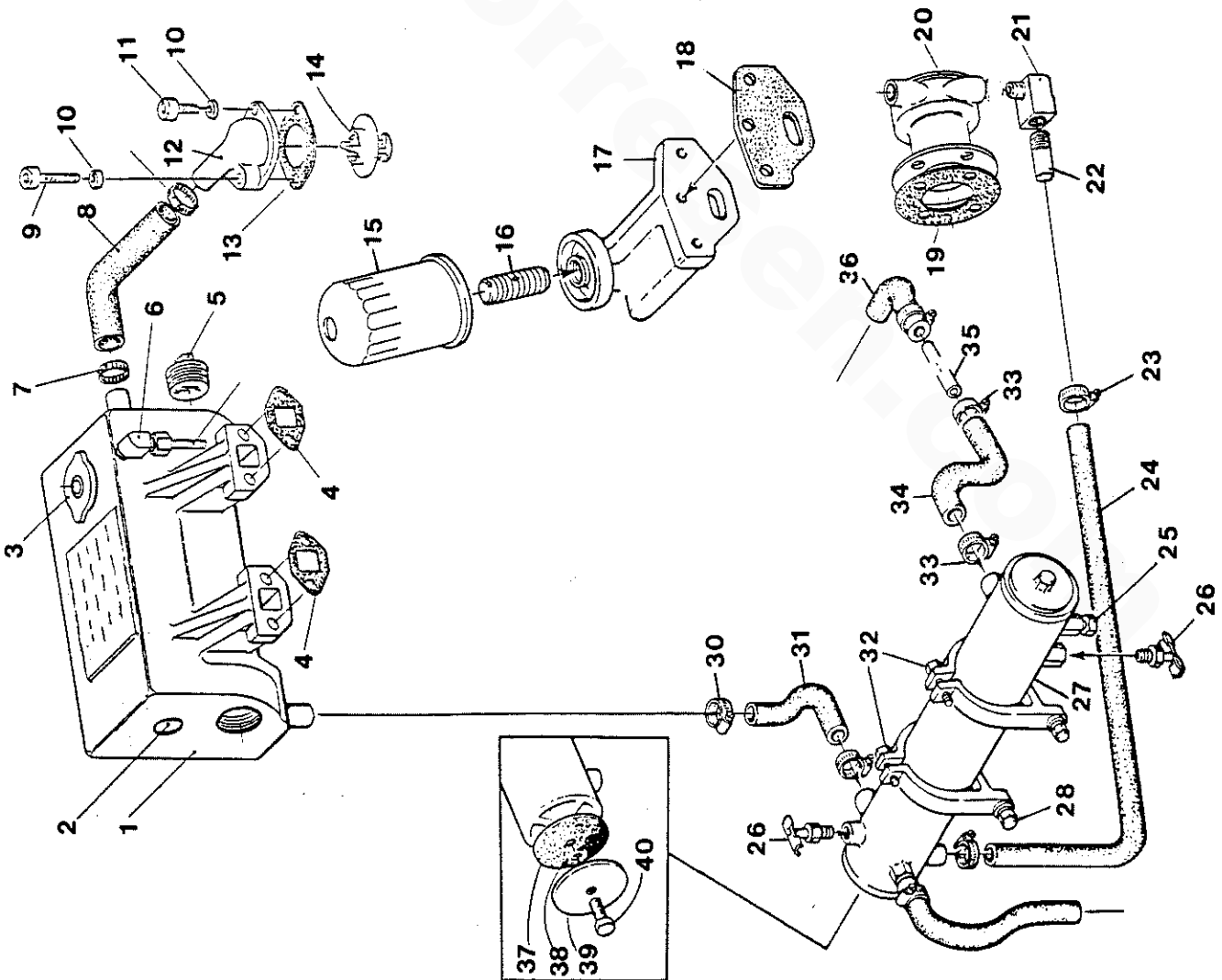
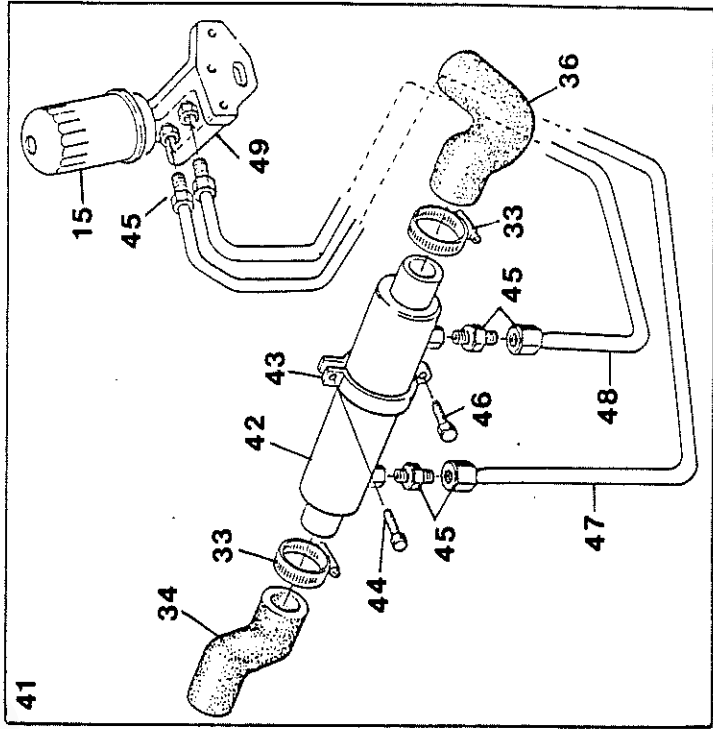
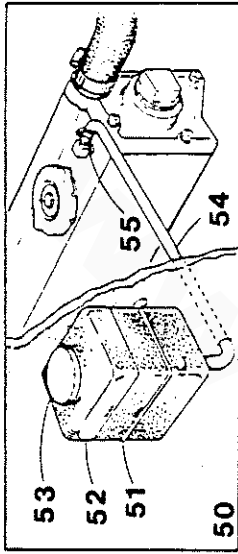

WESTERBEKE 40A - COOLING SYSTEM

REF	PN	NAME	REMARKS	QUAN
1	015564	MANIFOLD	EXHAUST	1
2	019334	PLUG	EXPANSION	1
3	024306	CAP	PRESSURE 15 PSI	1
4	011653	GASKET	MANIFOLD TO HEAD	2
5	019324	PLUG	1.5NPT	1
6	024907	ELBOW	MANIFOLD TO COOLANT RECOVERY TANK HOSE	1
7	021878	CLAMP	HOSE 20	2
8	011652	HOSE	THERMOSTAT TO MANIFOLD	1
9	031923	CAPSCREW	3/8NF X 2 SOCKET HEAD	1
10	031764	LOCKWASHER	3/8	2
11	031922	CAPSCREW	3/8NF X 1 SOCKET HEAD	1
12	012009	HOUSING	THERMOSTAT	1
13	012663	GASKET	THERMOSTAT HOUSING	1
14	024688	THERMOSTAT		1
15	011951	FILTER	LUBE OIL	1
16	013610	NIPPLE	OIL FILTER TO ADAPTER	1
17	036379	ADAPTER	LUBE OIL FILTER WITHOUT OIL COOLER	1
18	012669	GASKET	LUBE OIL FILTER ADAPTER TO BLOCK	1
19	011143	GASKET	SEA WATER PUMP MOUNTING	1
20	016423	PUMP	SEA WATER	1
21	036366	ELBOW	1/2NPT 45 DEGREE STREET	1
22	032230	NIPPLE	1/2NPT TO 7/8 HOSE	1
23	011386	CLAMP	HOSE 12	2
24	030166	HOSE	SEA WATER PUMP TO EXCHANGER	1
25	011885	ZINC		1
26	011471	PETCOCK		2
27	036896	EXCHANGER	HEAT	1
28-1	013619	CAPSCREW	M 8 X 30 DIN 933	2
28-2	031786	LOCKWASHER	M 8 DIN 127	2
28-3	031787	WASHER	M 8 DIN 125	2
29-1	036838	NIPPLE	3/4NPT TO 7/8 HOSE	1
29-2	036622	NIPPLE	3/4NPT TO 1 HOSE	1
30	021878	CLAMP	HOSE 20	2
31	024304	HOSE	MANIFOLD TO EXCHANGER	1
32-1	031506	CAPSCREW	1/4NC X 1-1/4	2
32-2	031752	LOCKWASHER	1/4	2
32-3	031753	WASHER	FLAT 1/4	2
33	021878	CLAMP	HOSE 20	4
34	036325	HOSE		1
35	036456	TUBE	WHEN OIL COOLER NOT USED	1
36	036324	HOSE		1
37	022851	GASKET	EXCHANGER END	2
38	019321	O-RING		2
39	022850	COVER	EXCHANGER END	2
40	022852	CAPSCREW	3/8NC X 1/2 BRASS	2

WESTERBEKE 40A - COOLING SYSTEM

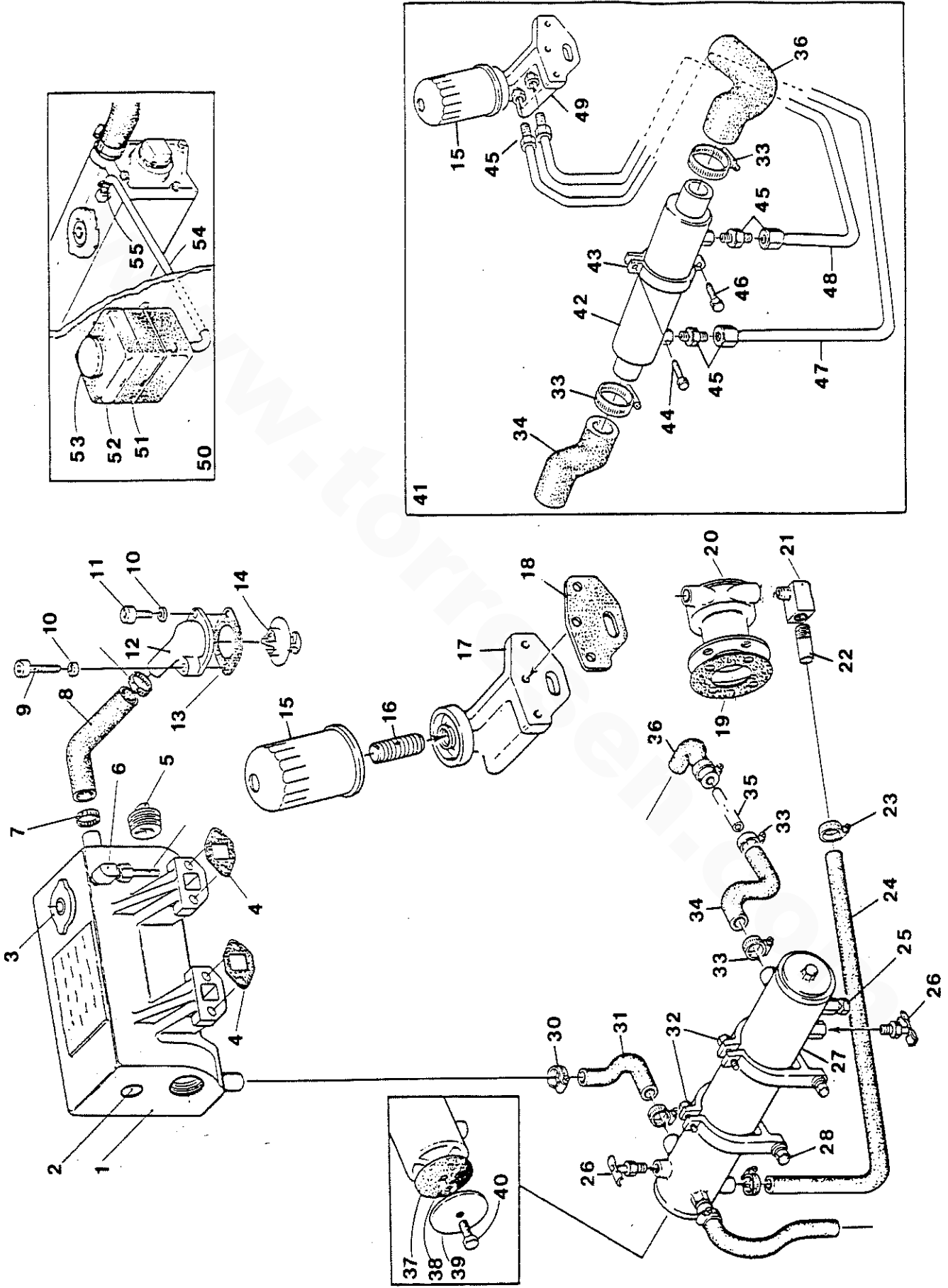

WESTERBEKE 40A - COOLING SYSTEM

REF	PN	NAME	REMARKS	QUAN
41	036260	KIT	OIL COOLER EXCLUDING REF 15,33,34 & 36	1
42	034484	COOLER	LUBE OIL	1
43	035181	CLAMP	OIL COOLER MOUNT	1
44-1	031506	CAPSCREW	1/4NC X 1-1/4	1
44-2	031752	LOCKWASHER	1/4	1
44-3	031753	WASHER	FLAT 1/4	1
45-1	013334	CONNECTOR	INCLUDING NUT AND FERRULE	4
45-2	013333	FERRULE		AR
46-1	031680	CAPSCREW	7/16NF X 1	1
46-2	031770	LOCKWASHER	7/16	1
47	036382	LINE	ADAPTER TO OIL COOLER	1
48	036381	LINE	OIL COOLER TO ADAPTER	1
49	018972	ADAPTER	LUBE OIL FILTER WITH OIL COOLER	1
50	024977	KIT	COOLANT RECOVERY TANK	1
51	024786	STRAP	COOLANT RECOVERY TANK MOUNT	1
52	024704	TANK	COOLANT RECOVERY	1
53	024858	CAP	COOLANT RECOVERY TANK	1
54	024637	TUBING	MANIFOLD TO RECOVERY TANK-INCHES REQD	30
55	024906	CLAMP	HOSE	2
56	031681	CAPSCREW	7/16NF X 1-1/4	2
57	031770	LOCKWASHER	7/16	2

WESTERBEKE 40A - FRESH WATER PUMP AND WATER INJECTED EXHAUST ELBOW

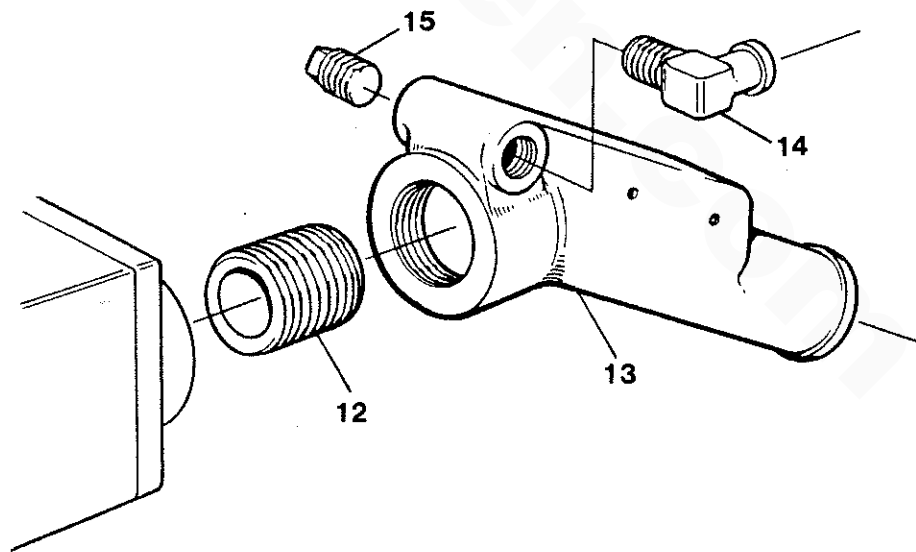
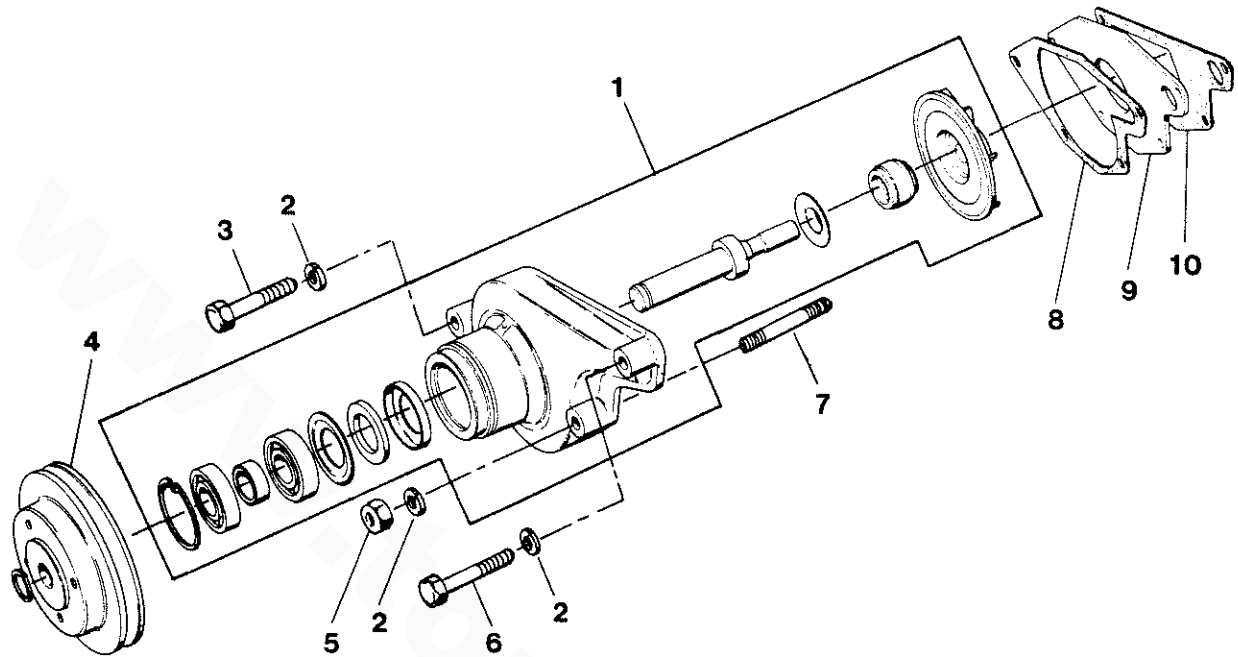

WESTERBEKE 40A - FRESH WATER PUMP AND WATER INJECTED EXHAUST ELBOW

REF	PN	NAME	REMARKS	QUAN
1-1	020035	PUMP	FRESH WATER	1
1-2	019933	KIT	WATER PUMP REPAIR	1
2	031758	LOCKWASHER	5/16	4
3	031584	CAPSCREW	5/16NF X 2	2
4	019987	PULLEY	FRESH WATER PUMP	1
5	031760	NUT	5/16NF	1
6	031583	CAPSCREW	5/16NF X 1-3/4	1
7	035388	STUD	5/16NF X 2-1/8	1
8	012673	GASKET	WATER PUMP TO PLATE	1
9	012655	PLATE	FRESH WATER PUMP TO BLOCK	1
10	012674	GASKET	PLATE TO BLOCK	1
11	036259	KIT	WATER INJECTED EXHAUST ELBOW	1
12	020439	NIPPLE	1.5NPT CLOSE	1
13	034486	ELBOW	WATER INJECTED EXHAUST 45 DEGREE	1
14-1	030183	ELBOW	1/2NPT TO 7/8 HOSE	1
14-2	036616	ELBOW	1/2NPT TO 1 HOSE	1
15	035747	PLUG	1/2NPT	1

WESTERBEKE 40A - SEA WATER PUMP

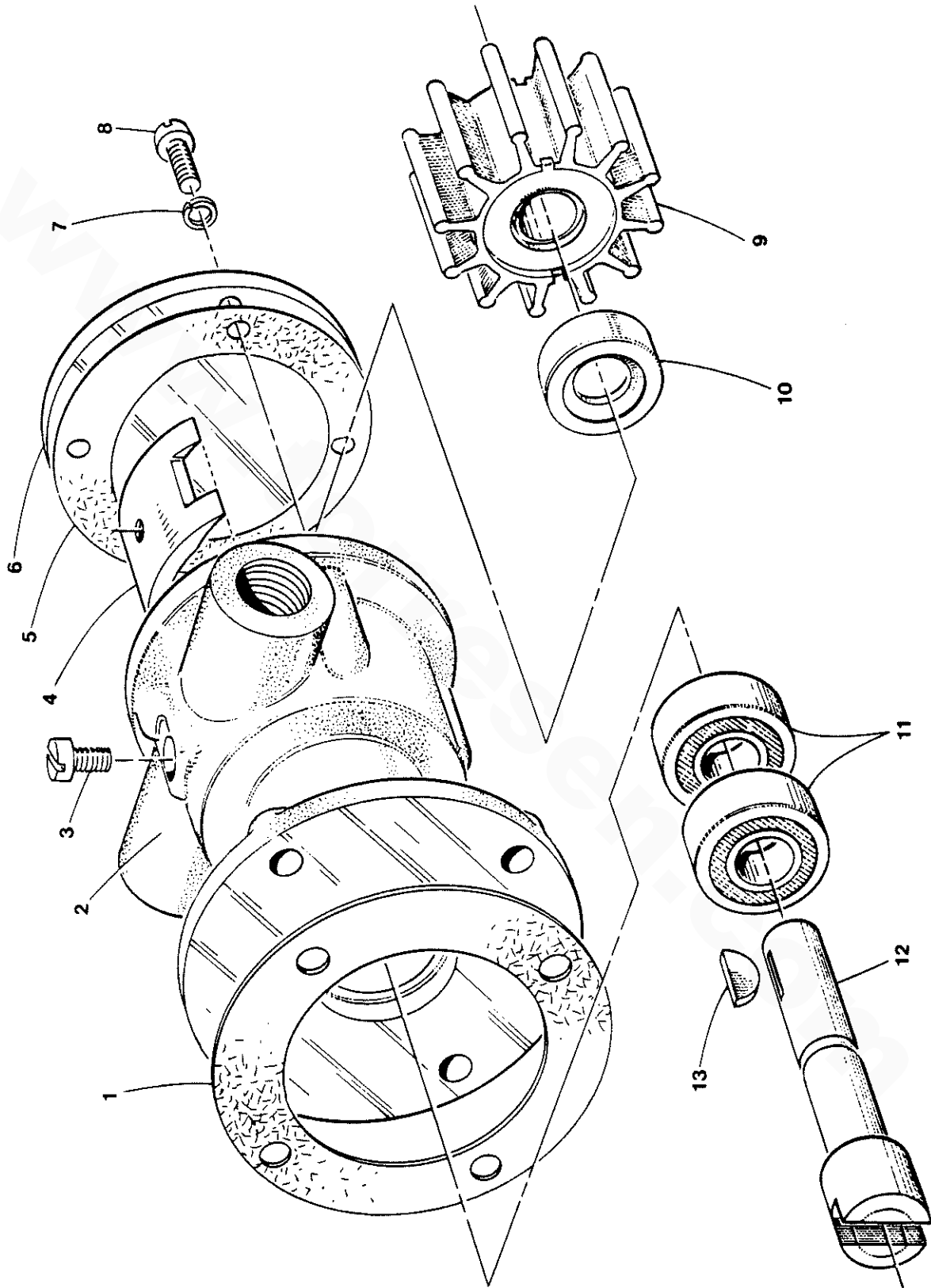

WESTERBEKE 40A - SEA WATER PUMP

REF	PN	NAME	REMARKS	QUAN
1	011143	GASKET	SEA WATER PUMP MOUNTING	1
2-1	016423	PUMP	SEA WATER	1
2-2	018169	HOUSING	SEA WATER PUMP BODY	1
2-3	018172	KIT	PUMP MAJOR REPAIR	1
3	018160	SCREW	BRASS-PUMP HOUSING TO CAM	1
4	018152	CAM		1
5	015153	GASKET	IMPELLER COVER	1
6	018171	COVER	IMPELLER	1
7	032183	LOCKWASHER		4
8	018151	SCREW	BRASS-IMPELLER COVER	4
9	033104	KIT	IMPELLER AND COVER GASKET	1
10	018159	SEAL		1
11	018170	BEARING		2
12	018176	SHAFT		1
13	018148	KEY	IMPELLER TO SHAFT	1

WESTERBEKE 40A - FUEL SYSTEM

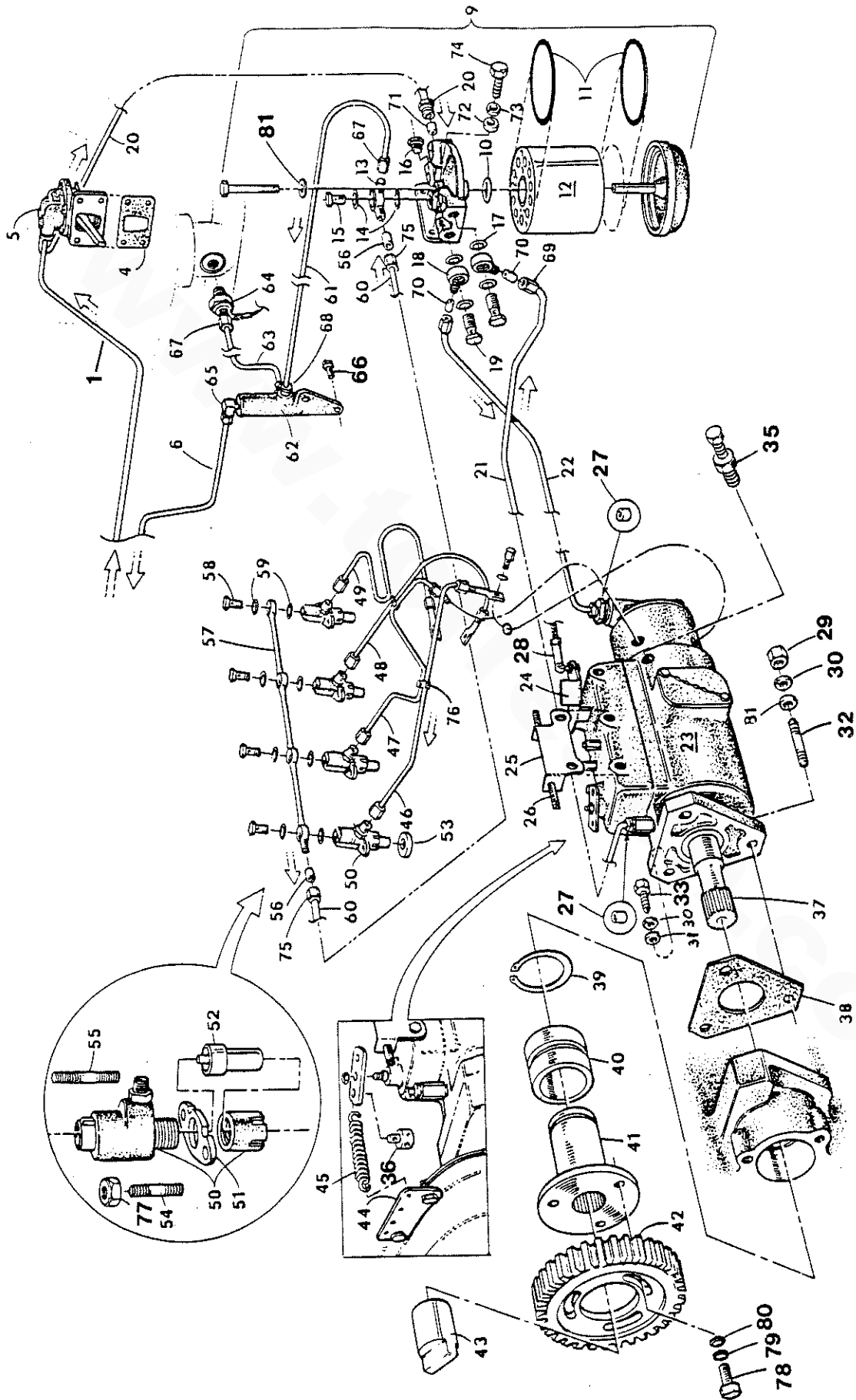

WESTERBEKE 40A - FUEL SYSTEM

REF	PN	NAME	REMARKS	QUAN
1	023909	HOSE	FUEL SUPPLY	1
2	031062	VALVE	CHECK	1
3	031061	WASHER	SEALING	1
4	016245	GASKET	LIFT PUMP MOUNT	1
5-1	016443	PUMP	FUEL LIFT	1
5-2	035125	KIT	FUEL LIFT PUMP REPAIR	1
6	034857	HOSE	FUEL RETURN	1
7	032974	FILTER	SEDIMENTER/WATER TRAP-OPTIONAL	1
8	031756	NUT	5/16NC	4
9	019509	FILTER	FUEL	1
10		O-RING	FUEL FILTER-SEE REF 12	1
11		GASKET SET	FUEL FILTER-SEE REF 12	1
12	014776	ELEMENT	FUEL FILTER INCL REF 10-11	1
13	011936	BANJO	FUEL RETURN	1
14	011944	WASHER	BANJO	2
15	012351	BOLT	BANJO	1
16-1	019505	PLUG	UNUSED FILTER PORT	1
16-2	019507	WASHER	FUEL FILTER PLUG	1
17	012522	WASHER	BANJO	4
18	011941	BANJO	FILTER TO INJECTION PUMP LINES	2
19	012350	BOLT	BANJO	2
20	019511	LINE	LIFT PUMP TO FILTER	1
21	014814	LINE	INJECTION PUMP TO FILTER	1
22	014813	LINE	FILTER TO INJECTION PUMP	1
23	014678	PUMP	FUEL INJECTION	1
24	016034	LEVER	THROTTLE	1
25	016033	BRACKET	IDLE SCREW	1
26	016539	SCREW	IDLE ADJUSTING	1
27	011934	FERRULE		2
28	019364	BALL JOINT	THROTTLE CABLE	1
29	031760	NUT	5/16NF	2
30	031758	LOCKWASHER	5/16	3
31	031759	WASHER	FLAT 5/16	3
32	012497	STUD		2
33	012561	CAPSCREW	5/16NF X 1-1/4 SOCKET HEAD FULL THREAD	1
34	019261	WASHER		1
35	019204	SCREW	BLEED ASSEMBLY	1
36	019370	PIVOT	FUEL SHUT-OFF LEVER	1
37	014744	SHAFT	INJECTION PUMP DRIVE	1
38	012402	GASKET	INJECTION PUMP MOUNT	1
39	031323	CIRCLIP	HUB	1
40-1	031324	BEARING	ASSEMBLY	1
40-2	031322	BUSHING	HUB	1
41	020004	HUB	DRIVE	1
42	019989	GEAR	INJECTION PUMP DRIVE	1
43-1	012614	SHAFT	SEA WATER PUMP DRIVE	1
43-2	023764	SHAFT	SEA WATER PUMP DRIVE 0.001 OS	1
44	019944	BRACKET	STOP LEVER SPRING	1
45	014674	SPRING	STOP LEVER	1

WESTERBEKE 40A - FUEL SYSTEM

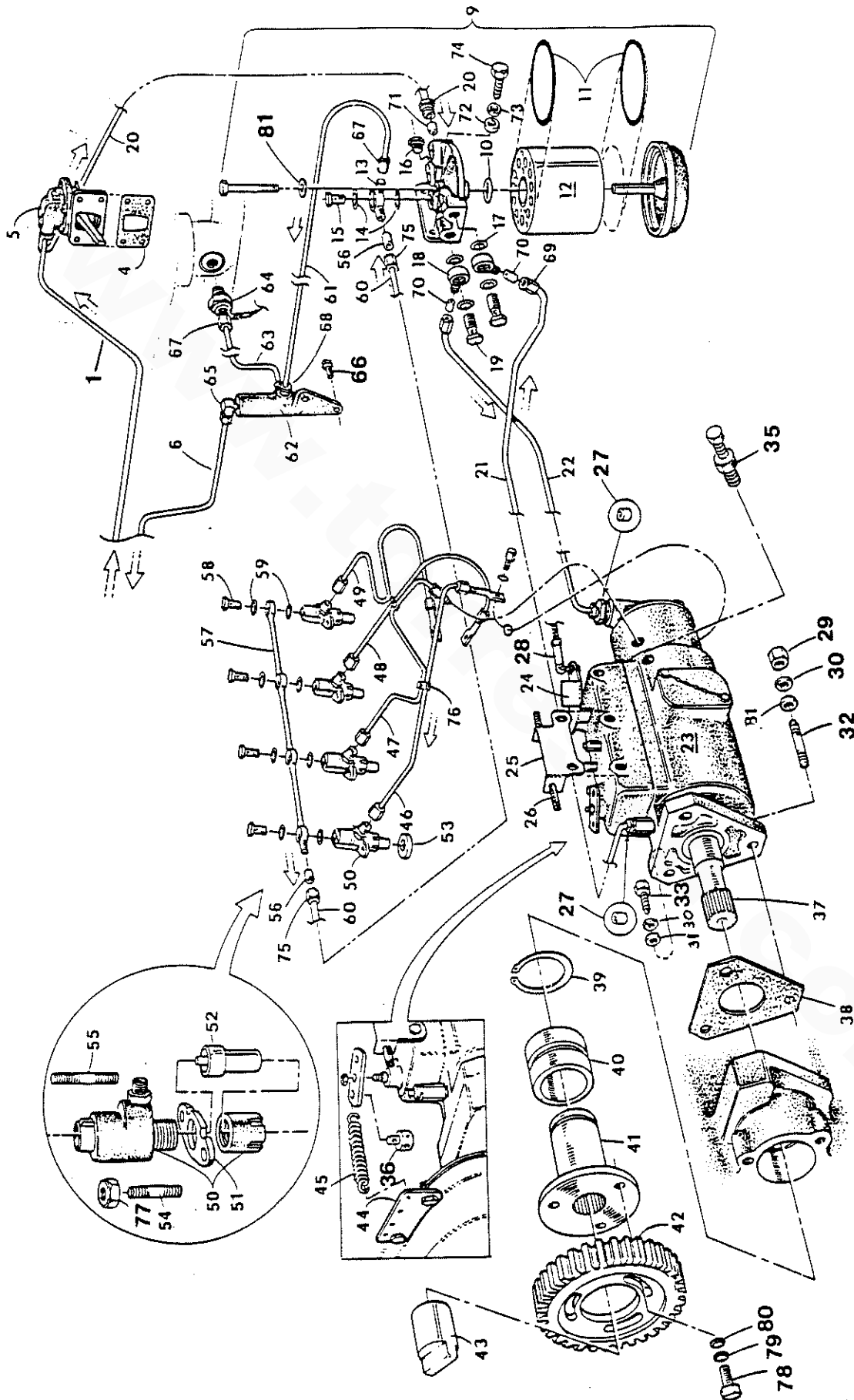

WESTERBEKE 40A - FUEL SYSTEM

REF	PN	NAME	REMARKS	QUAN
46	012641	LINE	INJECTOR 1	1
47	012645	LINE	INJECTOR 2	1
48	012646	LINE	INJECTOR 3	1
49	012647	LINE	INJECTOR 4	1
50	035374	INJECTOR	FUEL	4
51	012653	FLANGE	INJECTOR MOUNTING	4
52	035375	NOZZLE	INJECTOR	4
53	011945	WASHER		4
54	012495	STUD	INJECTOR-SHORT	4
55	012501	STUD	INJECTOR-LONG	4
56-1	019500	FERRULE	RUBBER-FUEL LINE	2
56-2	013343	FERRULE	BRASS-COMPRESSION	2
57	013517	LINE	INJECTOR RETURN	1
58	011935	BOLT	BANJO	4
59	011943	WASHER	BANJO M 8	8
60	019510	LINE	INJECTOR RETURN TO FILTER	1
61	015197	LINE	FILTER TO STANDPIPE	1
62-1	011014	STANDPIPE	WHEN OPTIONAL HEATER INSTALLED	1
62-2	013755	BRACKET	RAISES STANDPIPE WHEN ALTNR IN UP RT POS	1
63-1	023612	LINE	STANDPIPE TO HEATER	1
63-2	037394	LINE ASSY	STANDPIPE TO HEATER-BRACKET 013755	1
64	011530	HEATER	MANIFOLD 12 VDC - OPTIONAL	1
65	013345	ELBOW	1/8NPT MALE TO 3/16 COMPRESSION	1
66-1	031583	CAPSCREW	5/16NF X 1-3/4	2
66-2	031758	LOCKWASHER	5/16	2
67-1	013343	FERRULE	COMPRESSION 3/16	2
67-2	013344	NUT	COMPRESSION 3/16	2
68	013346	CONNECTOR	1/8NPT MALE TO 3/16 COMPRESSION	2
69	016676	NUT	COMPRESSION 1/4	2
70	019501	FERRULE	FUEL LINE	2
71	011934	FERRULE	FUEL LINE	2
72	031765	WASHER	FLAT 3/8	2
73	031764	LOCKWASHER	3/8	2
74	031630	CAPSCREW	3/8NF X 1	2
75	013344	NUT	COMPRESSION 3/16	2
76-1	023920	CLAMP	FUEL LINE	4
76-2		SCREW	10-32 X 7/8 RH	2
76-3		NUT	10-32 LOCKING	2
77	031760	NUT	5/16NF	8
78	031578	CAPSCREW	5/16NF X 3/4	3
79	031758	LOCKWASHER	5/16	3
80	031759	WASHER	FLAT 5/16	3
81	019442	WASHER		1

WESTERBEKE 40A - BACK END - TRANSMISSION - MOUNTING SYSTEM

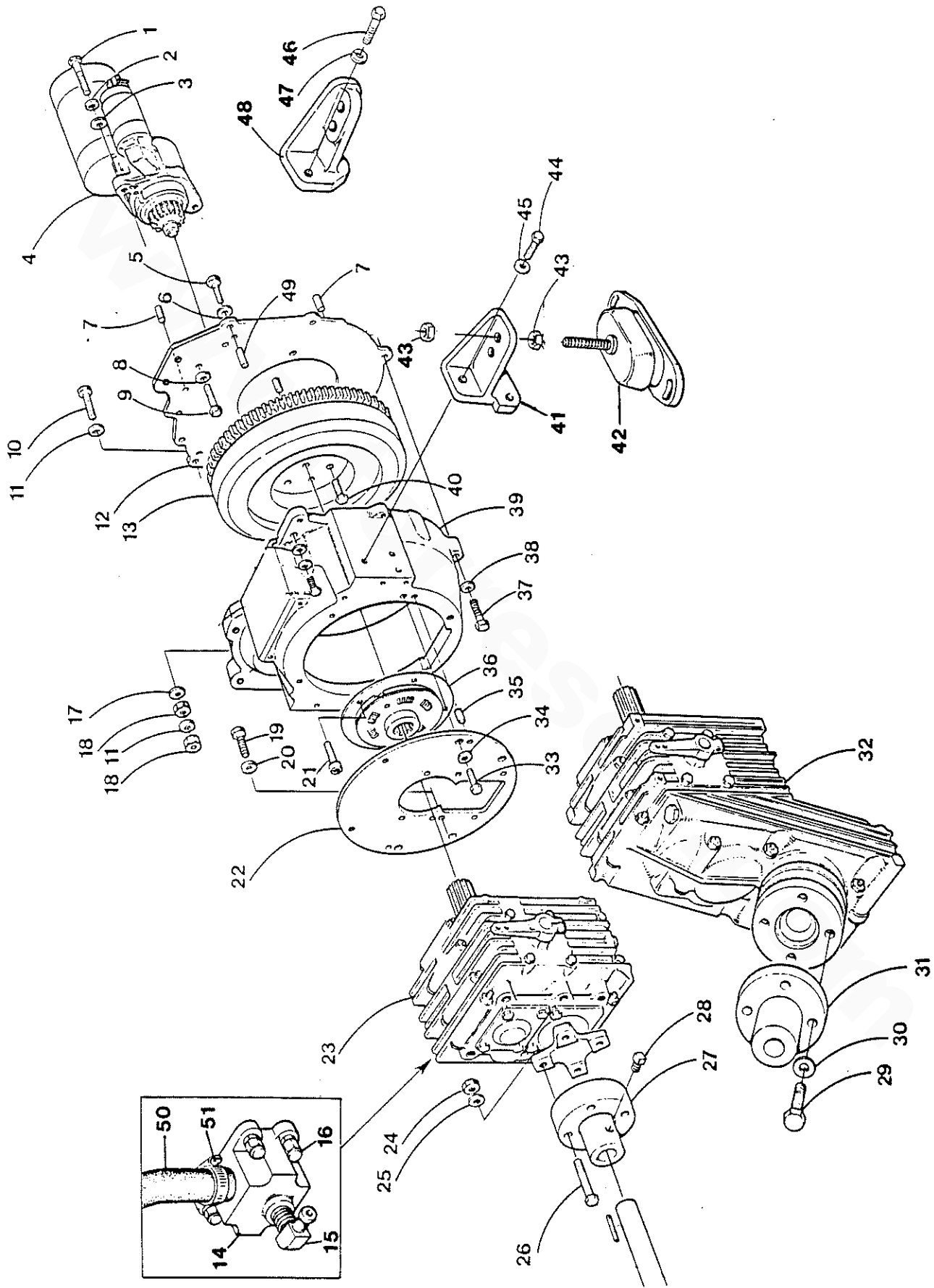

WESTERBEKE 40A - BACK END - TRANSMISSION - MOUNTING SYSTEM

REF	PN	NAME	REMARKS	QUAN
1	034589	CAPSCREW	M 10 X 30 DIN 933	2
2	019262	LOCKWASHER	M10 DIN 127	2
3	031789	WASHER	M10 DIN 125	2
4	030593	MOTOR	STARTER 12 VDC	1
5	034589	CAPSCREW	M10 X 30 DIN 933	4
6	019262	LOCKWASHER	M10 DIN 127	4
7	011498	DOWEL	BACKPLATE TO BLOCK	2
8	031764	LOCKWASHER	7/16	5
9	031630	CAPSCREW	7/16NF X 1	5
10	034833	CAPSCREW	M10 X 60 DIN 912 FULLY THREADED	1
11	019262	LOCKWASHER	M10 DIN 127	2
12	035332	PLATE	BACK	1
13-1	034502	FLYWHEEL	ASSEMBLY INCL RING GEAR-BALANCED	1
13-2	030230	GEAR	RING	1
14-1	034544	COOLER	HBW GEAR 7/8 HOSE	1
14-2	036648	COOLER	HBW GEAR 1 HOSE	1
15-1	030183	ELBOW	1/2NPT TO 7/8 HOSE	1
15-2	036614	ELBOW	3/4NPT TO 1 HOSE	1
16-1	017196	CAPSCREW	M 8 X 20 DIN 933	4
16-2	031786	LOCKWASHER	M 8 DIN 127	4
17	031789	WASHER	M10 DIN 125	1
18	015887	NUT	M10 DIN 934	2
19-1	020650	CAPSCREW	M 8 X 18 DIN 933 HBW150	6
19-2	013629	CAPSCREW	M10 X 25 DIN 933 HBW V-DRIVE	6
20-1	031786	LOCKWASHER	M 8 DIN 127 HBW150	6
20-2	031790	LOCKWASHER	M10 DIN 137B HBW V-DRIVE	6
21	024778	CAPSCREW	DAMPER TO FLYWHEEL	5
22-1	031267	ADAPTER	HBW150 TO HOUSING	1
22-2	030063	ADAPTER	HBW V-DRIVE TO HOUSING	1
23-1	031248	HBW GEAR	MODEL 150 1.6 TO 1	1
23-2	024631	HBW GEAR	MODEL 150 1.9 TO 1	1
23-3	030049	HBW GEAR	MODEL 150 2.6 TO 1	1
24	024950	NUT	M10 X 1.25 DIN 934	4
25	019262	LOCKWASHER	M10 DIN 127	4
26	031228	CAPSCREW	M10 X 1.25 X 30 DIN 961	4
27-1	023679	COUPLING	BORE 0.75	1
27-2	023680	COUPLING	BORE 0.875	1
27-3	023681	COUPLING	BORE 1.0	1
27-4	023682	COUPLING	BORE 1.125	1
27-5	023683	COUPLING	BORE 1.25	1
27-6	023684	COUPLING	BORE 1.375	1
27-7	023685	COUPLING	BORE 1.5	1
28-1	023450	SETSCREW	COUPLING 7/16NC X 1	2
28-2	023651	SETSCREW	COUPLING 3/8NC X 3/4	2
28-3	023652	SETSCREW	COUPLING 3/8NC X 1	2

WESTERBEKE 40A - BACK END - TRANSMISSION - MOUNTING SYSTEM

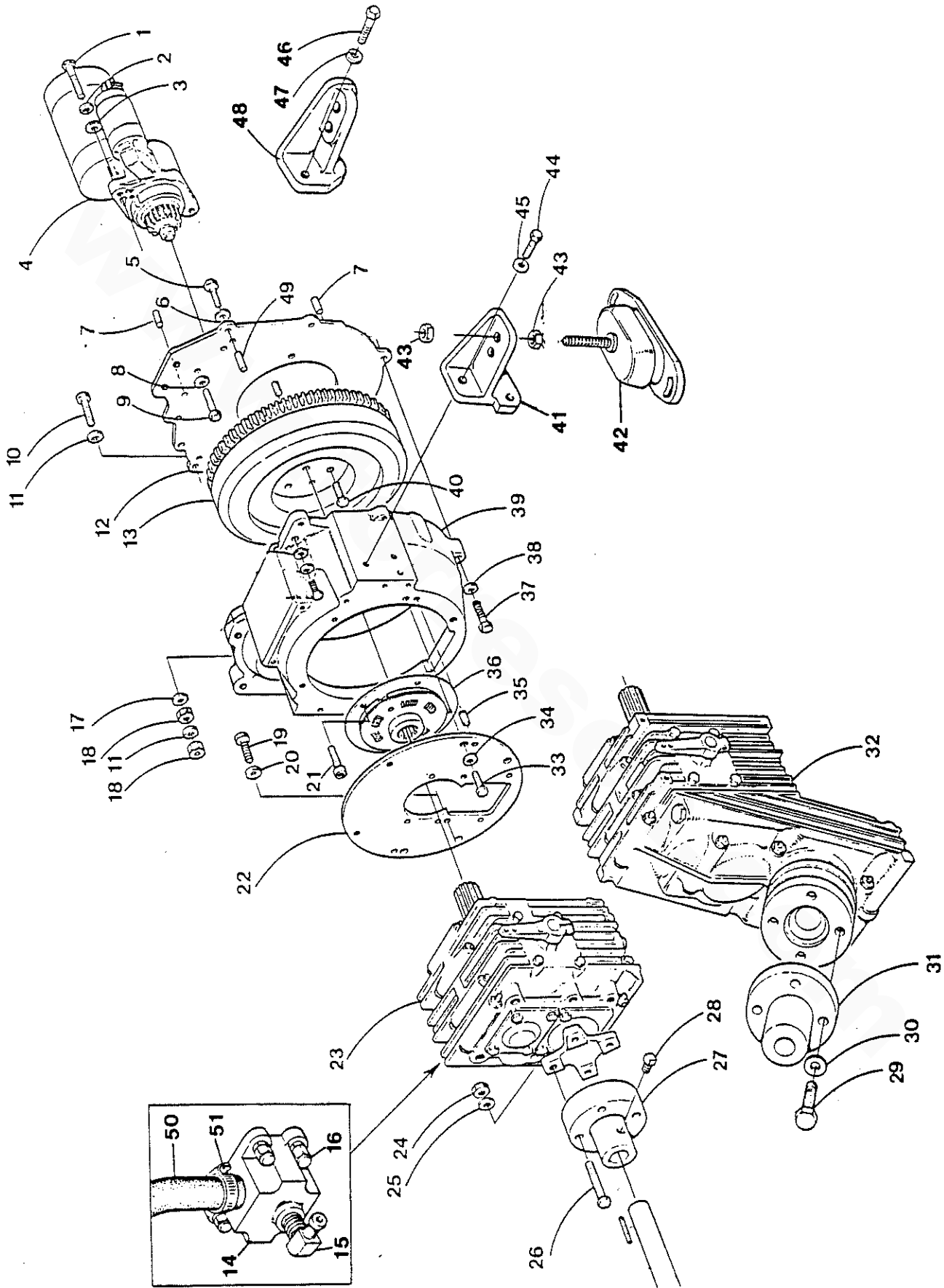

WESTERBEKE 40A - BACK END - TRANSMISSION - MOUNTING SYSTEM

REF	PN	NAME	REMARKS	QUAN
29	013629	CAPSCREW	M10 X 25 DIN 933	4
30	031790	LOCKWASHER	M10 DIN 137B	4
31-1	023706	COUPLING	V-DRIVE BORE 0.75	1
31-2	023707	COUPLING	V-DRIVE BORE 0.875	1
31-3	023708	COUPLING	V-DRIVE BORE 1.0	1
31-4	023709	COUPLING	V-DRIVE BORE 1.125	1
31-5	023710	COUPLING	V-DRIVE BORE 1.25	1
31-6	023711	COUPLING	V-DRIVE BORE 1.375	1
31-7	023712	COUPLING	V-DRIVE BORE 1.5	1
32-1	031249	HBW GEAR	V-DRIVE 1.8 TO 1	1
32-2	030048	HBW GEAR	V-DRIVE 2.1 TO 1	1
32-3	031250	HBW GEAR	V-DRIVE 3 TO 1	1
33-1	013629	CAPSCREW	M10 X 25 DIN 933 HBW150	6
33-2	034589	CAPSCREW	M10 X 30 DIN 933 HBW V-DRIVE	6
34	019262	LOCKWASHER	M10 DIN 127	6
35	019039	DOWEL	ADAPTER TO HOUSING	2
36	019398	DAMPER		1
37	031926	CAPSCREW	M10 X 35 DIN 933	2
38	031789	WASHER	M10 DIN 125	2
39	034682	HOUSING	FLYWHEEL	1
40	031928	CAPSCREW	7/16NF X 1 GRADE 8	5
41	034504	MOUNT <i>35404</i>	REAR	2
42-1	036341	ISOLATOR	INCLUDING LOCKING NUTS	4
42-2	036334	ISOLATOR	INCLUDING LOCKING NUTS-W40NA	4
43	036338	NUT	M16 DIN 985 LOCKING	8
44	034589	CAPSCREW	M10 X 30 DIN 933	6
45	019262	LOCKWASHER	M10 DIN 127	6
46	031681	CAPSCREW	7/16NF X 1-1/4	4
47	031770	LOCKWASHER	7/16	4
48-1	013132	MOUNT	FRONT LEFT	1
48-2	013133	MOUNT	FRONT RIGHT	1
49	013919	DOWEL	HOUSING TO BACKPLATE	2
50-1	019059	HOSE	7/8 ID-INCHES REQUIRED	24
50-2	011779	HOSE	1 ID-INCHES REQUIRED	24
51-1	011386	CLAMP	HOSE 12	2
51-2	011405	CLAMP	HOSE 16	2

WESTERBEKE 40A - HBW TRANSMISSION SHIFTING BRACKET

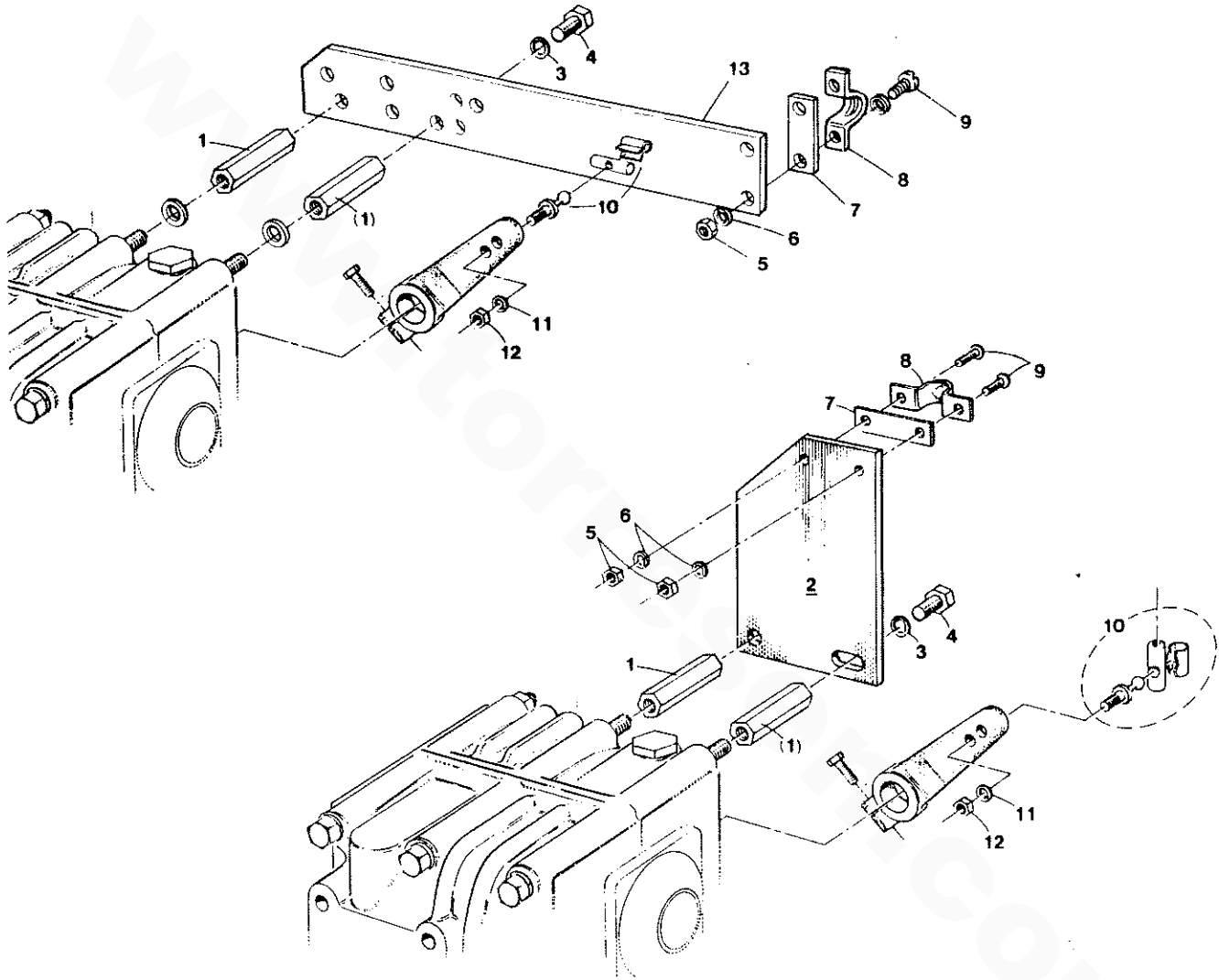

WESTERBEKE 40A - HBW TRANSMISSION SHIFTING BRACKET

REF	PN	NAME	REMARKS	QUAN
1	030756	NUT	PILLAR - M 8	2
2	030181	BRACKET	SHIFT CABLE - TOP ENTRY	1
3	031786	LOCKWASHER	M 8 DIN 127	2
4	013630	CAPSCREW	M 8 X 25 DIN 933	2
5	031847	NUT	10-32	2
6	031849	LOCKWASHER	10	2
7	013870	SHIM	CABLE CLAMP	1
8	013325	CLAMP	CABLE	1
9	031873	SCREW	10-32 X 5/8	2
10	033482	BALL JOINT		1
11	031752	LOCKWASHER	1/4	1
12	031754	NUT	1/4NF	1
13	032161	BRACKET	SHIFT CABLE - REAR ENTRY	1

WESTERBEKE 40A - STANDARD ALTERNATOR - OIL MANIFOLD

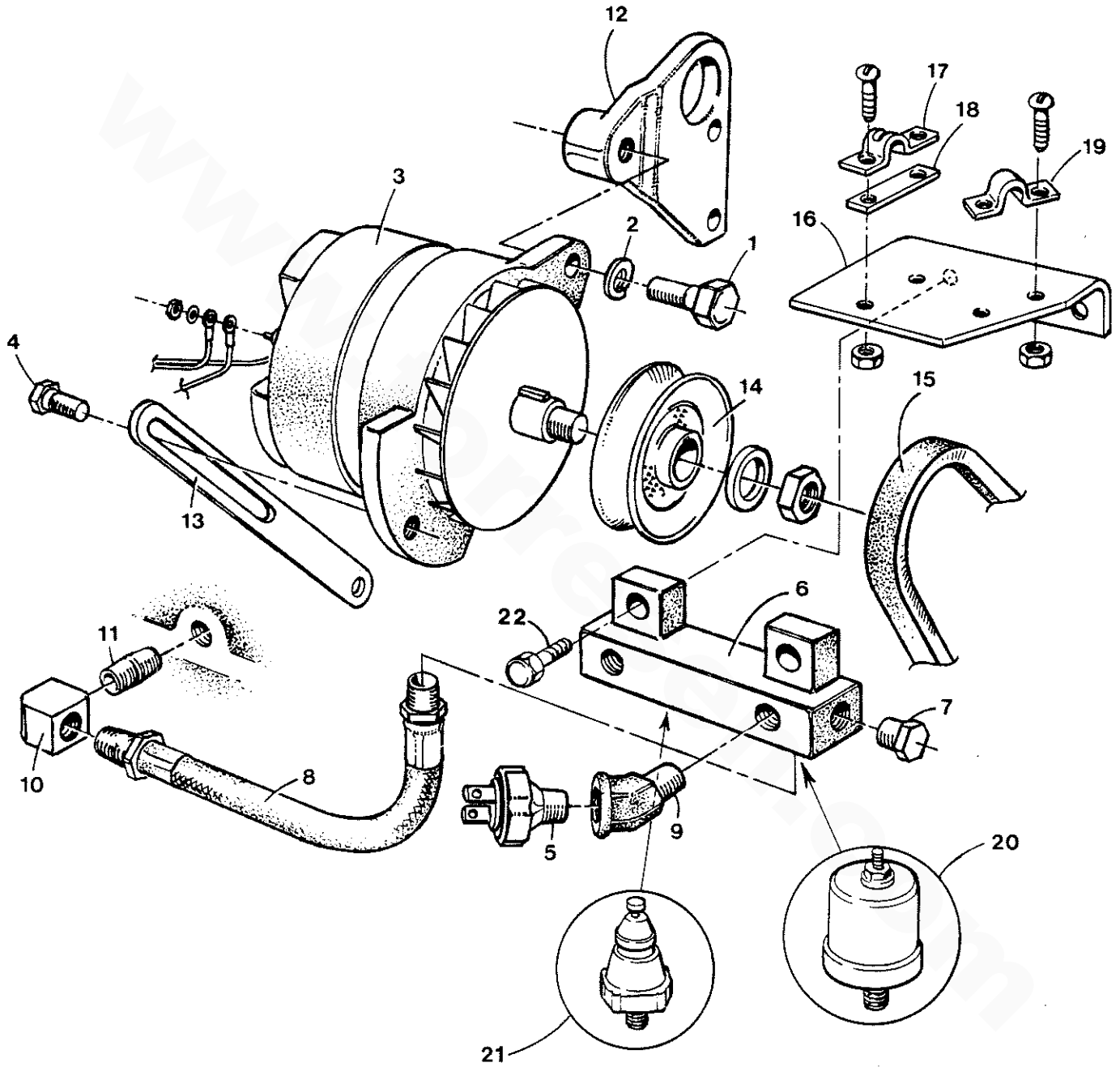

WESTERBEKE 40A - STANDARD ALTERNATOR - OIL MANIFOLD

REF	PN	NAME	REMARKS	QUAN
1	031709	CAPSCREW	1/2NC X 2	1
2	031776	LOCKWASHER	1/2	1
3	024684	ALTERNATOR	51 AMP 12 VDC	1
4-1	031555	CAPSCREW	5/16NC X 1	1
4-2	031758	LOCKWASHER	5/16	1
4-3	033381	WASHER	ADJUSTING STRAP	1
6	011969	MANIFOLD	OIL-TO MOUNT SWITCHES	1
7	011615	PLUG	1/8NPT	AR
8	036395	HOSE	BLOCK TO OIL MANIFOLD	1
9	015122	ELBOW	45 DEGREE	1
10	013328	ELBOW	90 DEGREE	1
11	011492	NIPPLE		1
12	012060	BRACKET	ALTERNATOR	1
13	035338	STRAP	ADJUSTING	1
14	011548	PULLEY	ALTERNATOR	1
15	035759	BELT	ALTERNATOR AND FRESH WATER PUMP	1
16	012955	BRACKET	THROTTLE AND STOP CABLES	1
17	013325	CLAMP	THROTTLE CABLE	1
18	013870	SHIM	THROTTLE CABLE CLAMP	1
19	013871	CLAMP	STOP CABLE	1
20	024132	SENDER	OIL PRESSURE	1
21-1	033935	SWITCH	OIL PRESSURE-ALARM-12 PIN HARNESS	1
21-2	034761	SWITCH	OIL PRESSURE-ALARM-8 PIN HARNESS	1
22-1	031631	CAPSCREW	3/8NF X 1-1/4	2
22-2	031764	LOCKWASHER	3/8	2
23	024152	SPACER	THROTTLE CABLE CLAMP	1

WESTERBEKE 40A - ELECTRICAL HARNESS

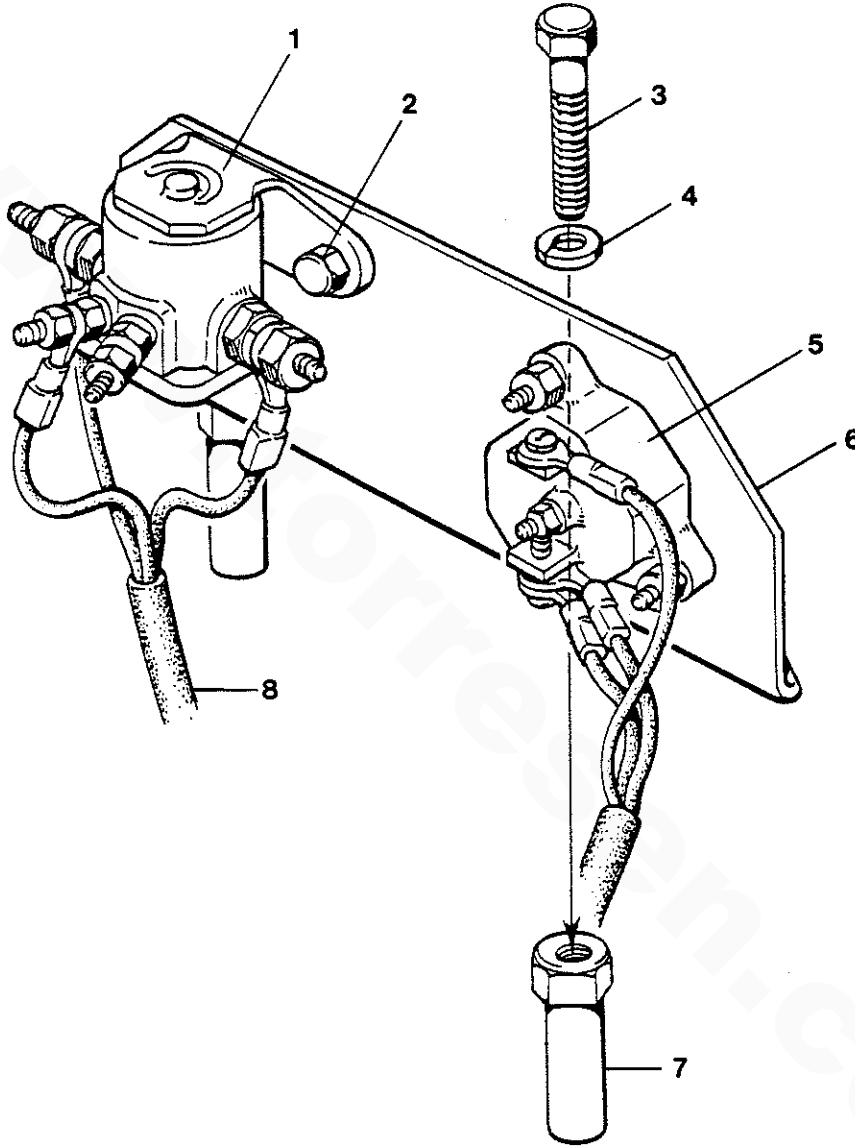

WESTERBEKE 40A - ELECTRICAL HARNESS

REF	PN	NAME	REMARKS	QUAN
1	024639	SOLENOID	PREHEAT	1
3	031678	CAPSCREW	7/16NF X 3/4	2
4	031770	LOCKWASHER	7/16	2
5	024683	BREAKER	CIRCUIT 20 AMP	1
6	035772	BRACKET	CIRCUIT BREAKER AND SOLENOID	1
7	020005	NUT	PILLAR	2
8-1	036079	HARNESS	8 PIN	1
8-2	036602	HARNESS	12 PIN	1
9	030125	SWITCH	WATER TEMPERATURE-ALARM	1
10	035109	SENDER	WATER TEMPERATURE	1
11	032119	BUSHING	REDUCER 1/2NPT TO 1/8NPT	2
12	013355	BUZZER	ALARM	1

www.torresen.com

WESTERBEKE 40A - INSTRUMENT PANEL

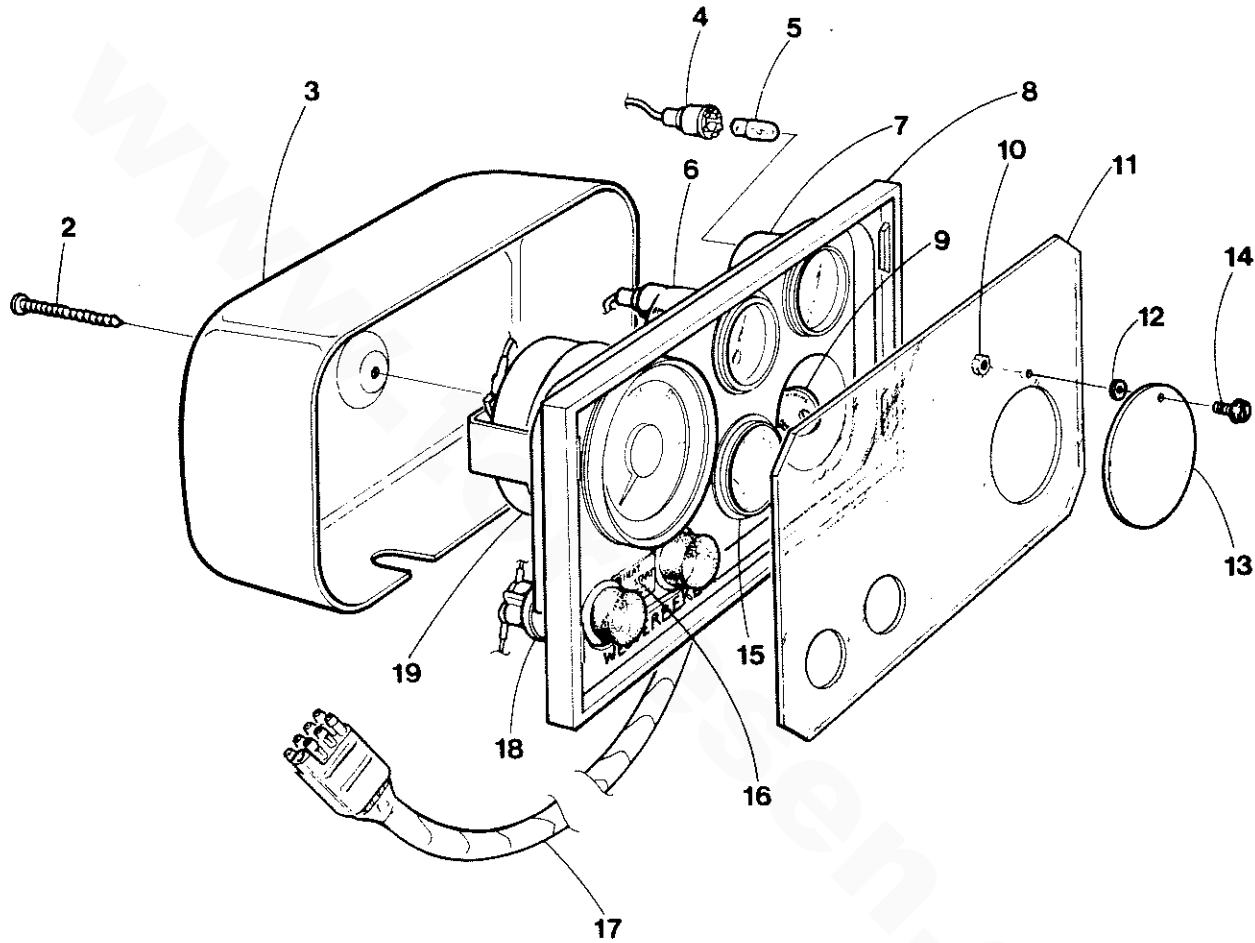

WESTERBEKE 40A - INSTRUMENT PANEL

REF	PN	NAME	REMARKS	QUAN
1	033866	PANEL	INSTRUMENT ASSEMBLY	1
2	030913	SCREW		1
3	030119	COVER	PANEL REAR	1
4	035118	HOLDER	LAMP-WEDGE BASE	AR
5	035114	LAMP	INSTRUMENT-WEDGE BASE	AR
6	035108	METER	WATER TEMPERATURE	1
7	035110	METER	OIL PRESSURE	1
8	033865	PANEL	PLATE	1
9	033693	SWITCH	KEY	1
10	030003	NUT	NYLON LOCKING 6-32	1
11	033684	COVER	FACEPLATE	1
12	030002	SPACER	NYLON	1
13	024996	WINDOW	KEYSWITCH COVER	1
14	030001	SCREW	NYLON 6-32 X 1/2 WASHER HEAD	1
15	035111	VOLTMETER	12 VDC	1
16	033682	DECAL	SWITCH IDENTIFICATION	1
17	030148	CABLE	PANEL TO ENGINE	1
18-1	033764	SWITCH	PUSH BUTTON START-PREHEAT	2
18-2	019031	CAP	SWITCH COVER REPLACEMENT	AR
19	011917	METER	TACHOMETER-HOUR	1
20	036630	DRAWING	TEMPLATE TO INSTALL PANEL	1

WESTERBEKE W40NA - ALTERNATORS AND COMPRESSOR MOUNTING SYSTEM

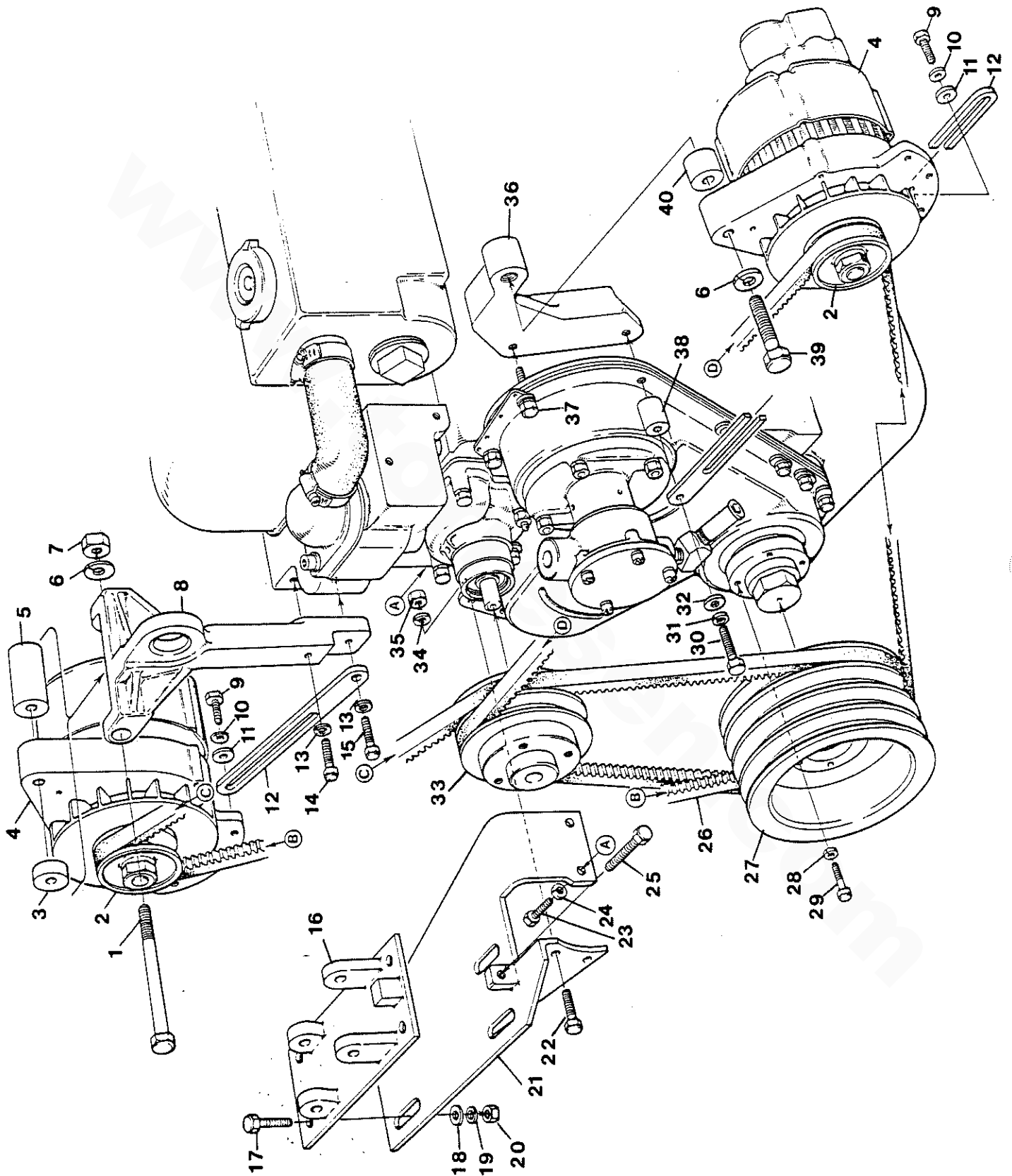

WESTERBEKE W40NA - ALTERNATORS AND COMPRESSOR MOUNTING SYSTEM

REF	PN	NAME	REMARKS	QUAN
1	031719	CAPSCREW	1/2NC X 4-1/2	1
2	011548	PULLEY	ALTERNATOR	2
3	036430	SPACER		1
4	024684	ALTERNATOR	51 AMP 12 VDC	2
5	036429	SPACER		1
6	031776	LOCKWASHER	1/2	2
7	031774	NUT	1/2NC	1
8	036427	BRACKET	ALTERNATOR	1
9	031553	CAPSCREW	5/16NC X 3/4	2
10	031758	LOCKWASHER	5/16	2
11	033381	WASHER	ADJUSTING STRAP	2
12	033064	STRAP	ADJUSTING	2
13	031764	LOCKWASHER	3/8	2
14	031633	CAPSCREW	3/8NF X 1-3/4	1
15	031632	CAPSCREW	3/8NF X 1-1/2	1
16	036452	BRACKET	COMPRESSOR	1
17	033537	CAPSCREW	3/8NC X 1-1/8	4
18	031765	WASHER	FLAT 3/8	4
19	031764	LOCKWASHER	3/8	4
20	031762	NUT	3/8NC	4
21	036413	BRACKET	COMPRESSOR	1
22	031553	CAPSCREW	5/16NC X 3/4	2
23		CAPSCREW	5/16NF	2
24	031758	LOCKWASHER	5/16	2
25	031274	CAPSCREW	3/8NC X 2 FULLY THREADED	1
26	033361	BELT	ALTERNATOR AND FRESH WATER PUMP	2
27	036428	PULLEY	4 GROOVE	1
28	031752	LOCKWASHER	1/4	4
29		CAPSCREW	1/4NF X 1-1/8	4
30	031559	CAPSCREW	5/16NC X 2	1
31	031758	LOCKWASHER	5/16	1
32	031759	WASHER	FLAT 5/16	1
33	012225	PULLEY	FRESH WATER PUMP 2 GROOVE	1
34	031758	LOCKWASHER	5/16	2
35	031756	NUT	5/16NC	2
36	036426	BRACKET	ALTERNATOR	1
37	031554	CAPSCREW	5/16NC X 7/8	1
38	033713	SPACER		1
39	031713	CAPSCREW	1/2NC X 3	1
40	031108	SPACER		1
41	036457	BELT	COMPRESSOR-MUST BE MATCHED PAIR	2
42	037248	DIAGRAM	WIRING	1

WESTERBEKE 40A - MISCELLANEOUS

REF	PN	NAME	REMARKS	QUAN
3	019934	GASKET SET	UPPER	1
4	020719	GASKET SET	LOWER	1
5	020720	GASKET SET	COMPLETE	1
6	032974	FILTER	SEDIMENTER/WATER TRAP	1
7	013758	PAINT	RED AEROSOL SPRAY CAN	1
8	015010	STRAINER	SEA WATER	1
9	020654	SPLITTER	ALTERNATOR OUTPUT	1
10	011988	KIT	FUEL HARDWARE	1
11	020502	MANUAL	TECHNICAL	1
12	012169	LINE	FLEXIBLE EXHAUST-STAINLESS STEEL 12 LONG	1
13-1	034936	MUFFLER	HYDRO-HUSH C (UNIVERSAL MOUNT)	1
13-2	033340	CONNECTOR	HOSE-STRAIGHT 1-7/8	AR
13-3	033341	CONNECTOR	HOSE 45 DEGREE 1-7/8	AR
13-4	033342	CONNECTOR	HOSE 90 DEGREE 1-7/8	AR
13-5	036680	ADAPTER	1-7/8 TO 2 HOSE	AR
13-6	033943	KIT	HOSE COUPLING AND CLAMPS	1
14	033327	VALVE	ANTI-SIPHON	1