



OPERATORS MANUAL

7A-1 and 11A-1 MARINE DIESEL ENGINES

PUBLICATION NO. 45145
1st Edition/April 2001



WESTERBEKE CORPORATION • MYLES STANDISH INDUSTRIAL PARK
150 JOHN HANCOCK ROAD, TAUNTON, MA 02780-7319 U.S.A.
TEL: (508)823-7677 • FAX: (508)884-9688 • WEBSITE: WWW.WESTERBEKE.COM



Member National Marine Manufacturers Association



OPERATORS MANUAL

7A-1 and 11A-1 MARINE DIESEL ENGINES

PUBLICATION NO. 45145
1st Edition/April 2001



WESTERBEKE CORPORATION • MYLES STANDISH INDUSTRIAL PARK
150 JOHN HANCOCK ROAD, TAUNTON, MA 02780-7319 U.S.A.
TEL: (508)823-7677 • FAX: (508)884-9688 • WEBSITE: WWW.WESTERBEKE.COM



Member National Marine Manufacturers Association

**CALIFORNIA
PROPOSITION 65 WARNING**
Diesel engine exhaust and some of its constituents are known to the State of California to cause cancer, birth defects, and other reproductive harm.

⚠ WARNING

Exhaust gasses contain Carbon Monoxide, an odorless and colorless gas. Carbon Monoxide is poisonous and can cause unconsciousness and death. Symptoms of Carbon Monoxide exposure can include:

- Dizziness
- Nausea
- Headache
- Weakness and Sleepiness
- Throbbing in Temples
- Muscular Twitching
- Vomiting
- Inability to Think Coherently

IF YOU OR ANYONE ELSE EXPERIENCE ANY OF THESE SYMPTOMS, GET OUT INTO THE FRESH AIR IMMEDIATELY. If symptoms persist, seek medical attention. Shut down the unit and do not restart until it has been inspected and repaired.



This WARNING DECAL is provided by WESTERBEKE and should be fixed to a bulkhead near your engine or generator.

WESTERBEKE also recommends installing CARBON MONOXIDE DETECTORS in the living/sleeping quarters of your vessel. They are inexpensive and easily obtainable at your local marine store.

INTRODUCTION

Read these safety instructions carefully. Most accidents are caused by failure to follow fundamental rules and precautions. Know when dangerous conditions exist and take the necessary precautions to protect yourself, your personnel, and your machinery.

The following safety instructions are in compliance with the American Boat and Yacht Council (ABYC) standards.

PREVENT ELECTRIC SHOCK

⚠ WARNING: Do not touch AC electrical connections while engine is running, or when connected to shore power. Lethal voltage is present at these connections!

- Do not operate this machinery without electrical enclosures and covers in place.
- Shut off electrical power before accessing electrical equipment.
- Use insulated mats whenever working on electrical equipment.
- Make sure your clothing and skin are dry, not damp (particularly shoes) when handling electrical equipment.
- Remove wristwatch and all jewelry when working on electrical equipment.
- Do not connect utility shore power to vessel's AC circuits, except through a ship-to-shore double throw transfer switch. Damage to vessel's AC generator may result if this procedure is not followed.
- Electrical shock results from handling a charged capacitor. Discharge capacitor by shorting terminals together with an insulated tool.

PREVENT BURNS — HOT ENGINE

⚠ WARNING: Do not touch hot engine parts or exhaust system components. A running engine gets very hot!

⚠ WARNING: Steam can cause injury or death!

- In case of an engine overheat, allow the engine to cool before touching the engine or checking the coolant.

PREVENT BURNS — FIRE

⚠ WARNING: Fire can cause injury or death!

- Prevent flash fires. Do not smoke or permit flames or sparks to occur near the fuel line, filter, fuel pump, or other potential sources of spilled fuel or fuel vapors. Use a suitable container to catch all fuel when removing the fuel line or fuel filters.
- Keep the compartment and the engine clean and free of debris to minimize the chances of fire. Wipe up all spilled fuel and engine oil.
- Be aware — diesel fuel will burn.

PREVENT BURNS — EXPLOSION

⚠ WARNING: Explosions from fuel vapors can cause injury or death!

- Follow re-fueling safety instructions. Keep the vessel's hatches closed when fueling. Open and ventilate cabin after fueling. Check below for fumes/vapor before running the blower. Run the blower for four minutes before starting your engine.
- All fuel vapors are highly explosive. Use extreme care when handling and storing fuels. Store fuel in a well-ventilated area away from spark-producing equipment and out of the reach of children.
- Do not fill the fuel tank(s) while the engine is running.
- Shut off the fuel service valve at the engine when servicing the fuel system. Take care in catching any fuel that might spill. DO NOT allow any smoking, open flames, or other sources of fire near the fuel system or engine when servicing. Ensure proper ventilation exists when servicing the fuel system.
- Do not alter or modify the fuel system.
- Be sure all fuel supplies have a positive shutoff valve.
- Be certain fuel line fittings are adequately tightened and free of leaks.
- Make sure a fire extinguisher is installed nearby and is properly maintained. Be familiar with its proper use. Extinguishers rated ABC by the NFPA are appropriate for all applications encountered in this environment.

ACCIDENTAL STARTING

⚠ WARNING: Accidental starting can cause injury or death!

- Disconnect the battery cables before servicing the engine. Remove the negative lead first and reconnect it last.
- Make certain all personnel are clear of the engine before starting.
- Make certain all covers, guards, and hatches are re-installed before starting the engine.

BATTERY EXPLOSION

⚠ WARNING: Battery explosion can cause injury or death!

- Do not smoke or allow an open flame near the battery being serviced. Lead acid batteries emit hydrogen, a highly explosive gas, which can be ignited by electrical arcing or by lit tobacco products. Shut off all electrical equipment in the vicinity to prevent electrical arcing during servicing.
- Never connect the negative (-) battery cable to the positive (+) connection terminal of the starter solenoid. Do not test the battery condition by shorting the terminals together. Sparks could ignite battery gases or fuel vapors. Ventilate any compartment containing batteries to prevent accumulation of explosive gases. To avoid sparks, do not disturb the battery charger connections while the battery is being charged.
- Avoid contacting the terminals with tools, etc., to prevent burns or sparks that could cause an explosion. Remove wristwatch, rings, and any other jewelry before handling the battery.
- Always turn the battery charger off before disconnecting the battery connections. Remove the negative lead first and reconnect it last when servicing the battery.

BATTERY ACID

⚠ WARNING: Sulfuric acid in batteries can cause severe injury or death!

- When servicing the battery or checking the electrolyte level, wear rubber gloves, a rubber apron, and eye protection. Batteries contain sulfuric acid which is destructive. If it comes in contact with your skin, wash it off at once with water. Acid may splash on the skin or into the eyes inadvertently when removing electrolyte caps.

TOXIC EXHAUST GASES

⚠ WARNING: Carbon monoxide (CO) is a deadly gas!

- Ensure that the exhaust system is adequate to expel gases discharged from the engine. Check the exhaust system regularly for leaks and make sure the exhaust manifold/water-injected exhaust elbow is securely attached.
- Be sure the unit and its surroundings are well ventilated. Run blowers when running the generator set or engine.
- Don't run the generator set or engine unless the boat is equipped with a functioning marine carbon monoxide detector that complies with ABYC A-24. Consult your boat builder or dealer for installation of approved detectors.
- For additional information refer to ABYC T-22 (educational information on Carbon Monoxide).

⚠ WARNING: Carbon monoxide (CO) is an invisible odorless gas. Inhalation produces flu-like symptoms, nausea or death!

- Do not use copper tubing in diesel exhaust systems. Diesel fumes can rapidly destroy copper tubing in exhaust systems. Exhaust sulfur causes rapid deterioration of copper tubing resulting in exhaust/water leakage.
- Do not install exhaust outlet where exhaust can be drawn through portholes, vents, or air conditioners. If the engine exhaust discharge outlet is near the waterline, water could enter the exhaust discharge outlet and close or restrict the flow of exhaust. Avoid overloading the craft.
- Although diesel engine exhaust gases are not as toxic as exhaust fumes from gasoline engines, carbon monoxide gas is present in diesel exhaust fumes. Some of the symptoms or signs of carbon monoxide inhalation or poisoning are:

Dizziness	Throbbing in temples
Headache	Muscular twitching
Nausea	Weakness and sleepiness
Vomiting	Inability to think coherently

AVOID MOVING PARTS

⚠ WARNING: Rotating parts can cause injury or death!

- Do not service the engine while it is running. If a situation arises in which it is absolutely necessary to make operating adjustments, use extreme care to avoid touching moving parts and hot exhaust system components.



SAFETY INSTRUCTIONS

- Do not wear loose clothing or jewelry when servicing equipment; tie back long hair and avoid wearing loose jackets, shirts, sleeves, rings, necklaces or bracelets that could be caught in moving parts.
- Make sure all attaching hardware is properly tightened. Keep protective shields and guards in their respective places at all times.
- Do not check fluid levels while the engine is operating.

HAZARDOUS NOISE

 **WARNING: High noise levels can cause hearing loss!**

- Never operate an engine without its muffler installed.
- Do not run engines for long periods with their enclosures open.

 **WARNING: Do not work on machinery when you are mentally or physically incapacitated by fatigue!**

ENGINE INSTALLATIONS

Preparations to install an engine should begin with a thorough examination of the American Boat and Yacht Council's (ABYC) standards. These standards are a combination of sources including the USCG and the NFPA.

Sections of the ABYC standards of particular interest are:

- P-1 Exhaust systems
- P-4 Inboard engines
- E-9 DC Electrical systems

All installations must comply with the Federal Code of Regulations (FCR).

ABYC, NFPA AND USCG PUBLICATIONS FOR INSTALLING DIESEL ENGINES

Read the following ABYC, NFPA and USCG publications for safety codes and standards. Follow their recommendations when installing your engine.

ABYC (American Boat and Yacht Council)
Safety Standards for Small Craft

Order from:

ABYC
3069 Solomons Island Rd.
Edgewater, MD 21037

NFPA (National Fire Protection Association)
Fire Protection Standard for Motor Craft

Order from:

NFPA
11 Tracy Drive
Avon Industrial Park
Avon, MA 02322

USCG (United States Coast Guard)
USCG 33CFR183

Order from:

U.S. Government Printing Office
Washington, D.C. 20404

INSTALLATION

When installing WESTERBEKE engines and generators, it is important that strict attention be paid to the following information:

CODES AND REGULATIONS

Federal regulations, ABYC guidelines and safety codes must be complied with when installing engines and generators in a marine environment.

SIPHON-BREAK

For installations where the exhaust manifold/water-injected exhaust elbow is close to or will be below the vessel's waterline, provisions *must* be made to install a siphon-break in the raw water supply hose to the exhaust elbow. This hose *must* be looped a minimum of 20 in. (51 cm) above the vessel's waterline. *Failure to use a siphon-break when the exhaust manifold injection port is at or below the load waterline will result in raw water damage to the engine and possible flooding of the boat.*

If you have any doubt about the position of the water-injected exhaust elbow relative to the vessel's waterline under any of the vessel's various operating conditions or when the vessel is not underway, *install a siphon-break*. This precaution is necessary to protect your engine.

NOTE: *A siphon-break requires periodic inspection and cleaning to ensure proper operation. Failure to properly maintain a siphon-break can result in catastrophic engine damage. Consult the siphon-break manufacturer for a proper maintenance schedule.*

EXHAUST SYSTEM

The exhaust hose must be certified for marine use. The system must be designed to prevent water from entering the exhaust under any sea conditions and at any angle of the vessel's hull.

A detailed 40-page Marine Installation Manual covering gasoline and diesel, engines and generators, is available from your WESTERBEKE dealer.



TABLE OF CONTENTS

Introduction	2	Cooling System (continued)	
Warranty Procedures.....	2	Raw Water Pump.....	22
Product Software.....	2	Inspecting/Changing the Raw Water Pump Impeller..	22
Notes, Caution and Warnings.....	2	Raw Water Intake.....	22
Model No./Serial No. Location.....	2	Raw Water Intake Strainer.....	22
Component Locations.....	3	Siphon-Break.....	23
Understanding the Diesel Engine.....	3	Draining the Cooling System.....	23
Ordering Parts.....	3	Air Intake Filter	24
Spares and Accessories.....	3	Description.....	24
Protecting Your Investment.....	3	Air Filter.....	24
7A-1 Diesel Engine Specifications	4	Maintenance.....	24
7A-1 Diesel Engine Parts Identification	5	Water Heater	24
11A-1 Diesel Engine Specifications	6	Water Heater Installations.....	24
11A-1 Diesel Engine Parts Identification	7	Fuel System	25
Preparations for Initial Start-Up	8	Diesel Fuel.....	25
Diesel Fuel.....	8	Fuel Additives.....	25
Care of the Fuel Supply.....	8	Care of the Fuel Supply.....	25
Fuel Additives.....	8	Fuel Lift Pump.....	25
Engine Oil.....	8	Fuel Filter.....	25
Transmission Fluid.....	8	Replacing the Fuel Filter.....	25
Pre-Start Inspection.....	8	Fuel Lines.....	26
Starting/Stopping Procedure	9	Fuel Filter/Water Separator.....	26
Electric Starting.....	9	Fuel Injection Pump.....	26
Electric Starting Procedure.....	9	Fuel Injector.....	26
Low Battery Electric Starting Procedure.....	9	Bleeding the Fuel System.....	26
Manual Starting (Hand Cranking).....	9	Spare Parts.....	26
Automatic Decompression Device.....	10	DC Electrical System	27
Cold Starting Device.....	10	12 Volt DC Control Circuit.....	27
Manual Starting Procedure.....	11	Control Panel.....	27
Starting Under Cold Conditions.....	12	Engine Circuit Breaker.....	27
Operating the Engine.....	12	Battery.....	27
Initial Start-Up Check List.....	12	Battery Care.....	27
Stopping the Engine.....	12	Checking the Service Battery.....	27
Engine Break-In Procedure	13	Alternator Troubleshooting.....	28
Engine Break-In Procedure.....	13	Testing the Alternator.....	28
Break-In Check List.....	13	Checking the Service Battery.....	29
Transmission Break-In.....	13	7A-1 Marine Diesel Engine Wiring Diagram #45593.....	30
Daily Operation	13	7A-1 Marine Diesel Engine Wiring Schematic #45593.....	31
Daily Operation Check-List.....	13	11A-1 Marine Diesel Engine Wiring Diagram #44542.....	32
Transmission.....	13	11A-1 Marine Diesel Engine Wiring Schematic #44542.....	33
Maintenance Schedule	14	Glow Plugs (Model 7A-1 only)	34
Exhaust System	16	Engine Adjustments	35
Description.....	16	Tightening the Cylinder Head.....	35
Siphon-Break.....	16	Valve Clearance Adjustment.....	35
Exhaust System Precautions.....	16	Engine Compression Test.....	35
Carbon Monoxide.....	16	Testing the Fuel Injector.....	36
Carbon Monoxide Warning Decal.....	16	Removing the Fuel Injector.....	36
Carbon Monoxide Detectors.....	17	Fuel Injector Components.....	36
Insulation.....	17	Checking the Injection Starting Pressure.....	36
Overcranking.....	17	Tightness of the Valve Seat.....	37
Lubrication System	18	Inspecting the Spray Pattern.....	37
Description.....	18	Checking the Nozzle Body and Needle Valve.....	37
Oil Pressure Relief Valve.....	18	Reassembly.....	37
Low Oil Pressure Alarm Switch.....	18	Injector Installation.....	37
Engine Oil.....	18	Drive Belt Adjustment.....	38
Checking the Oil.....	18	Checking Belt Tension.....	38
Changing the Oil.....	19	Adjusting Belt Tension.....	38
Removing the Old Oil.....	19	Engine Troubleshooting	39
Changing the Oil Filter (Model 11A-1 only).....	19	Hurth HBW Transmission	42
Adding the New Oil.....	20	Hurth HBW Transmission Troubleshooting	45
Testing the Oil Pressure.....	20	Lay-Up and Recommissioning	46
Cooling System	21	7A-1 & 11A-1 Torque Specifications.....	48
Raw Water Cooling System.....	21	Standard Hardware/Sealants & Lubricants.....	49
Thermostat.....	21	Metric Conversions.....	50
Checking/Replacing the Thermostat.....	21	Standard and Metric Conversion Data.....	51
Coolant Temperature Switch.....	21	Suggested Spare Parts Kits.....	52



INTRODUCTION

This WESTERBEKE Diesel Engine is a product of WESTERBEKE'S many years of experience and advanced technology. We take great pride in the superior durability and dependable performance of our engines and generators. Thank you for selecting WESTERBEKE.

This is the Operators Manual for the 7A-1 and 11A-1 Marine Diesel Engines. Most of the information in this manual applies to both models; where information applies to only one of the two models, the applicable model name will be indicated. A Parts Catalog is also provided for your engine, and a Service Manual is available from your WESTERBEKE dealer. If you are planning to install this equipment, contact your WESTERBEKE dealer for WESTERBEKE'S Installation Manual.

In order to get the full use and benefit from your engine, it is important that you operate and maintain it correctly. This manual is designed to help you do this. Please read this manual carefully and observe all the safety precautions throughout. Should your engine require servicing, contact your nearest WESTERBEKE dealer for assistance.

WARRANTY PROCEDURES

Your WESTERBEKE Warranty is included in the documentation package. If you have not received a customer identification card registering your warranty 60 days after submitting the warranty registration form, please contact the factory in writing with model information, including the unit's serial number and commission date.

Customer Identification Card



Customer Identification

WESTERBEKE OWNER
MAIN STREET
HOMETOWN, USA

Model 7A-1
 Expires 3/16/02
 Ser. #74860/197-E003

Your WESTERBEKE 7A-1/11A-1 Engine serial number is an alphanumeric number that indicates the date of manufacture. The date code is at the end of the serial number, and consists of a character followed by three numbers. The character indicates the decade (D=1990s, E=2000s), the first number after the character represents the year in the decade, and the second and third numbers after the character represent the month of manufacture.

PRODUCT SOFTWARE

Product software (tech data, parts lists, manuals, brochures and catalogs) provided from sources other than WESTERBEKE are not within WESTERBEKE's control.

WESTERBEKE CANNOT BE RESPONSIBLE FOR THE CONTENT OF SUCH SOFTWARE, MAKES NO WARRANTIES OR REPRESENTATIONS WITH RESPECT THERETO, INCLUDING ACCURACY, TIMELINESS OR COMPLETENESS THEREOF AND WILL IN NO EVENT BE LIABLE FOR ANY TYPE OF DAMAGE OR INJURY INCURRED IN CONNECTION WITH OR ARISING OUT OF THE FURNISHING OR USE OF SUCH SOFTWARE.

WESTERBEKE customers should keep in mind the time span between printings of WESTERBEKE product software and the unavoidable existence of earlier WESTERBEKE product software. The product software provided with WESTERBEKE products, whether from WESTERBEKE or other suppliers, must not and cannot be relied upon exclusively as the definitive authority on the respective product. It not only makes good sense but is imperative that appropriate representatives of WESTERBEKE or the supplier in question be consulted to determine the accuracy and currentness of the product software being consulted by the customer.

NOTES, CAUTIONS AND WARNINGS

As this manual takes you through the operating procedures, maintenance schedules, and troubleshooting of your marine engine, critical information will be highlighted by NOTES, CAUTIONS, and WARNINGS. An explanation follows:

NOTE: *An operating procedure essential to note.*

CAUTION: *Procedures which, if not strictly observed, can result in the damage or destruction of your engine.*

WARNING: *Procedures which, if not properly followed, can result in personal injury or loss of life.*

MODEL NO./SERIAL NO. LOCATION

The engine's model number and serial number are located on an identification plate mounted on the engine block, below the exhaust manifold/elbow. Take the time to enter this information on the illustration of the nameplate shown below, as this will provide a quick reference when seeking technical information and/or ordering repair parts.



ENGINE IDENTIFICATION PLATE



COMPONENT LOCATIONS

Component locations in this manual are referenced from the front of the engine which is the end at which the raw water pump is located. Left and right sides are determined as follows: imagine straddling the engine, facing the front of the engine: the left side is at your left, the right side is at your right.

UNDERSTANDING THE DIESEL ENGINE

The diesel engine closely resembles the gasoline engine, since the mechanism is essentially the same. The cylinder is arranged above a closed crankcase. The crankshaft is of the same general type as on a gasoline engine, and the diesel engine has the same types of valves, camshaft, piston, connecting rod and lubricating system.

Therefore, to a great extent, a diesel engine requires the same preventive maintenance as a gasoline engine. The most important factors are proper ventilation and proper maintenance of the fuel, lubricating and cooling systems. Fuel filter elements must be replaced at the time periods specified, and frequent checking for contaminants (water, sediment, etc.) in the fuel system is also essential. Another important factor is the consistent use of the same brand of high detergent diesel lubrication oil designed specifically for diesel engines.

The diesel engine does differ from the gasoline engine, however, in its method of handling and firing of fuel. The carburetor and ignition systems are replaced by a single component – the fuel injection pump – which performs the function of both.

ORDERING PARTS

Whenever replacement parts are needed, always provide the engine model number and serial number. You must provide us with this information so we may properly identify your engine. In addition, include a complete part description and part number for each part needed (see the Parts List). Insist upon Westerbeke packaged parts because *will fit* or generic parts are frequently not made to the same specifications as original equipment.

SPARES AND ACCESSORIES

Certain spare parts will be needed to support and maintain your WESTERBEKE engine when cruising (see *SUGGESTED SPARE PARTS KITS*). Often even a simple item such as a proper fuel filter can be difficult to obtain along the way. WESTERBEKE can provide you with a suggested spares and accessories brochure to assist you in preparing an on-board inventory of the proper WESTERBEKE parts.

PROTECTING YOUR INVESTMENT

Care at the factory during assembly and thorough testing have resulted in a WESTERBEKE engine capable of many thousands of hours of dependable service. However, the manufacturer cannot control how or where the engine is installed in the vessel or the manner in which the unit is operated and serviced in the field. This is up to the buyer/owner-operator.

NOTE: *Six important steps to ensure long engine life:*

- Proper engine installation.
- An efficient well-designed exhaust system that includes an anti-siphon break to prevent water from entering the engine.
- Changing the engine oil every 100 operating hours.
- Proper maintenance of all engine components according to the maintenance schedule in this manual.
- Use clean, filtered diesel fuel.
- Winterize your engine according to the *LAY-UP AND RECOMMISSIONING* section in this manual.

7A-1 DIESEL ENGINE SPECIFICATIONS

ENGINE SPECIFICATIONS

Engine Type	Diesel, four-cycle, one cylinder, raw water cooled, vertical, in-line overhead valve mechanism
Aspiration	Naturally aspirated
Governor	Mechanical, centrifugal type
Combustion System	Direct injected
Bore and Stroke	3.23 in. x 2.17 in. (82.0 mm x 55.0 mm)
Piston Displacement	17.7 cu. in. (290 cm ³)
Crankshaft Direction of Rotation	Clockwise, when viewed from the front (raw water pump end)
Compression Ratio	20:1
Maximum Torque (at 2500 rpm)	11.0 ft/lbs (1.5 kg-m)
Manual Starting System	Hand-crank, with automatic decompression device
Engine Stop	Manual type
Dimensions	
NOTE: An inserted standard crank handle increases the width by 4.5 in (115 mm)	Height: 17.1 in (433.7 mm) Width: 14.9 in (379.2 mm) Length: 22.5 in (571.3 mm)
Dry Weight	151 lbs (68.5 kg)
Max. Angle of Installation	Not to exceed 10°
Max. Angle of Operation	Not to exceed 15° in all directions

TUNE-UP SPECIFICATIONS

Compression Pressure	478.5 psi (33.6 kg/cm ²) standard 435.0 psi (30.6 kg/cm ²) minimum
Valve Seat Angle	Intake 45°; Exhaust 45°
Valve Clearance (engine cold)	Intake 0.008 in. (0.2 mm) Exhaust 0.008 in. (0.2 mm)
Engine Timing	39.0 mm BTDC static
Injector Pressure	2900 psi (203.9 kg/cm ²)
Engine Speed	Idle: 1000 – 1200 rpm Cruise: 2000 – 2500 rpm Maximum: 2900 – 3000 rpm

FUEL SYSTEM

Fuel System	Open flow, self-priming, self-bleeding
Fuel	No. 2 diesel oil, cetane rating of 45 or higher
Fuel Lift Pump	Mechanical 1.6 ft. (0.5 m) lift max.
Fuel Injection Pump	Bosch type
Fuel Injector	Direct injection
Fuel Injection Timing	39 mm BTDC static
Injector Pressure	2900 psi (203.9 kg/cm ²)
Fuel Consumption (full load)	0.46 U.S. gal./hr. (1.76 liter/hr.)
Fuel Filter	Primary, replaceable filter
Fuel Supply and Return Lines	1/4 in. (6.35 mm) I.D. minimum 5/16 in. (7.94 mm) I.D. maximum
Air Flow (engine combustion)	15.3 cfm (0.43 cmm)

LUBRICATION SYSTEM

Lubrication System	Forced lubrication by gear-driven pump
Sump Capacity	1.3 qts. (1.25 liters)
Operating Oil Pressure (engine hot)	25.6–56.9 psi (1.8–4.0 kg/cm ²)
Oil Grade	API specification CF or CG-4 SAE 30, 10W-30, 15W-40
Lube oil Strainer	Full-flow, internal

COOLING SYSTEM

Cooling System	Raw water-cooled block, thermostatically controlled
Operating Temperature	130–150°F (55–66°C)
Raw Water Pump	Positive displacement, neoprene impeller, gear-driven, self-priming
Raw Water Flow, at 3600 rpm	7.399–8.456 gpm (7–8 lpm)
Raw Water Connection	1/2 in. (12.7 mm) I.D.

EXHAUST SYSTEM

Emission Control Systems	Meets U.S.C.G. Regulation 33 CFR 183
Exhaust Manifold/Elbow	Cast aluminum, raw water cooled
Exhaust Elbow Connection	1-1/2 in. (38.1 mm) I.D.

ELECTRICAL SYSTEM

Electrical System	12 volts DC, negative ground, circuit breaker protected
Battery Charging Alternator	30 amp, 12 volts, belt-driven, with solid state internal regulator
Starting Motor	12 volt solenoid, actuated shift
Cold Cranking Amps	70 amps @ 71°F (22°C)

TRANSMISSION

General	<i>HURTH HBW 40 Standard Transmission</i> , case-hardened helical gears, with a servo-operated multiple disc clutch
Gear Ratio (optional)	2.05:1
Propeller	12 D x 8 P two blade RH 12 D x 6 P three blade RH Propeller used must allow the engine to reach its rated rpm at full open throttle in forward gear, underway
Lubricating Fluid	<i>ATF-type A or DEXTRON - II or III</i>
Transmission Sump Capacity	0.37 qts (0.35 liters)
Propeller Shaft Direction of Rotation	Right hand—standard transmission



7A-1 DIESEL ENGINE PARTS IDENTIFICATION

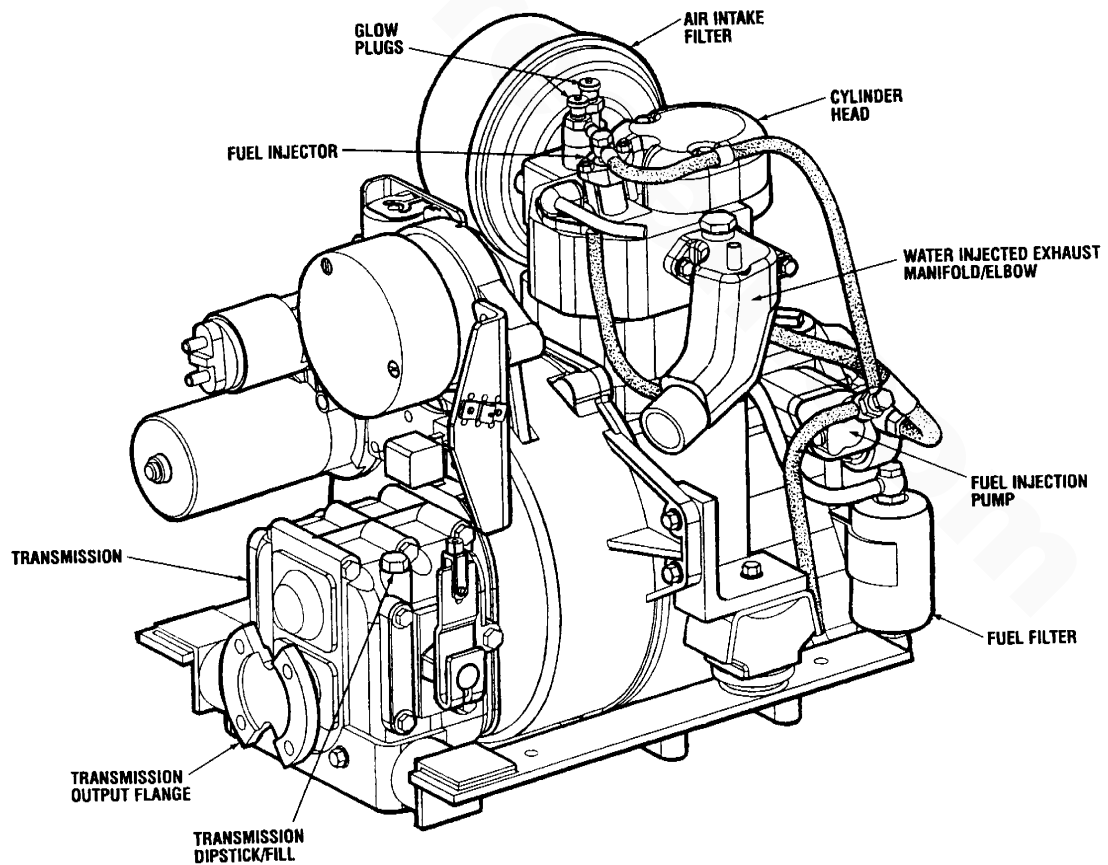
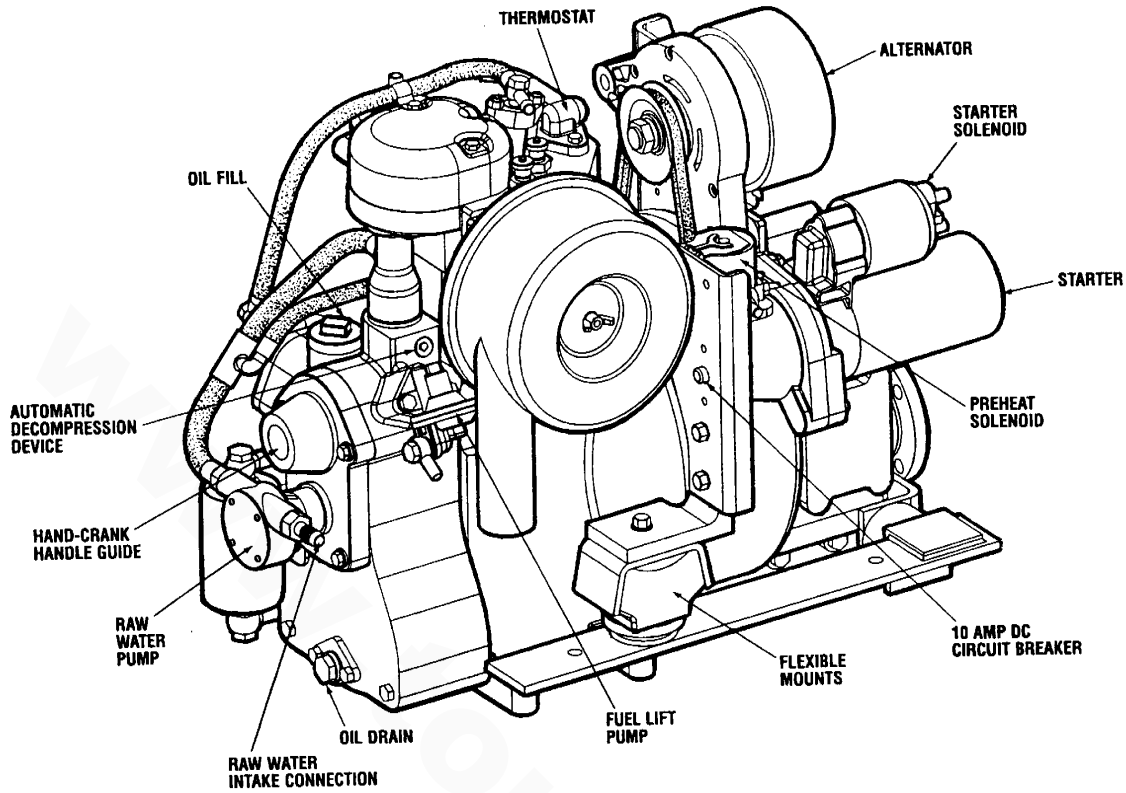

11A-1 DIESEL ENGINE SPECIFICATIONS

ENGINE SPECIFICATIONS

Engine Type	Diesel, four-cycle, one cylinder, raw water cooled, vertical, in-line overhead valve mechanism
Aspiration	Naturally aspirated
Governor	Mechanical, centrifugal type
Combustion System	Direct injected
Bore and Stroke	3.74 in. x 2.91 in. (95.0 mm x 74.0 mm)
Piston Displacement	31.95 cu. in. (524.0 cm ³)
Crankshaft Direction of Rotation	Clockwise, when viewed from the front (raw water pump end)
Compression Ratio	20:1
Maximum Torque at (2400 rpm)	21.3 ft/lbs (2.9 kg-m)
Manual Starting System	Hand-crank, with automatic decompression device
Engine Stop	Manual type
Dimensions	
NOTE: An inserted standard crank handle increases the width by 4.5 in. (115 mm)	Height: 21.0 in (532 mm) Width: 21.3 in (540 mm) Length: 23.8 in (603 mm)
Dry Weight	238 lbs (108 kg)
Max. Angle of Installation	Not to exceed 10°
Max. Angle of Operation	Not to exceed 15° in all directions

TUNE-UP SPECIFICATIONS

Compression Pressure	478.5 psi (33.6 kg/cm ²) standard 435.0 psi (30.6 kg/cm ²) minimum
Valve Seat Angle	Intake 45°; Exhaust 45°
Valve Clearance (engine cold)	Intake 0.008 in. (0.2 mm) Exhaust 0.008 in. (0.2 mm)
Engine Timing	60.0 mm BTDC static
Injector Pressure	2537 psi (178.3 kg/cm ²)
Engine Speed	Idle: 1000 – 1200 rpm Cruise: 2000 – 2500 rpm Maximum: 2900 – 3000 rpm

FUEL SYSTEM

Fuel System	Open flow, self-priming, self-bleeding
Fuel	No. 2 diesel oil, cetane rating of 45 or higher
Fuel Lift Pump	Mechanical 1.6 ft. (0.5 m) lift max.
Fuel Injection Pump	Bosch type
Fuel Injector	Direct Injection
Fuel Injection Timing	60 mm BTDC static
Injector Pressure	2537.5 psi (178.4 kg/cm ²)
Fuel Consumption (full load)	0.46 U.S. gal./hr. (1.76 liter/hr.)
Fuel Filter	Primary replaceable filter
Fuel Supply and Return Lines	1/4 in. (6.35 mm) I.D. minimum 5/16 in. (7.94 mm) I.D. maximum
Air Flow (engine combustion)	27.7 cfm (0.78 cmm)

LUBRICATION SYSTEM

Lubrication System	Forced lubrication by gear-driven pump
Sump Capacity	1.7 qts. (1.6 liter)
Operating Oil Pressure (engine hot)	25.6–56.9 psi (1.8–4.0 kg/cm ²)
Oil Grade	API specification CF or CG-4 SAE 30, 10W-30, 15W-40
Oil Filter	Full-flow, paper element, spin-on type

COOLING SYSTEM

Cooling System	Raw water-cooled block, thermostatically controlled
Operating Temperature	130–150°F (55–66°C)
Raw Water Pump	Positive displacement, neoprene impeller, gear-driven, self-priming
Raw Water Flow, at 3600 rpm	7.399–8.456 gpm (7–8 lpm)
Raw Water Connection	1/2 in. (12.7 mm) I.D.

EXHAUST SYSTEM

Emission Control Systems	Meets U.S.C.G. Regulation 33 CFR 183
Exhaust Manifold/Elbow	Cast aluminum, raw water cooled
Exhaust Elbow Connection	1-1/2 in. (38.1 mm) I.D.

ELECTRICAL SYSTEM

Electrical System	12 volts DC, negative ground, circuit breaker protected
Battery Charging Alternator	30 amp, 12 volts, belt-driven, with solid state internal regulator
Starting Motor	12 volt solenoid, actuated shift
Cold Cranking Amps	60 amps @ 66°F (19°C)

TRANSMISSION

General	<i>HURTH HBW 40 Standard Transmission, case-hardened helical gears, with a servo-operated multiple disc clutch</i>
Gear Ratio (optional)	2.05:1
Propeller	14 D x 8 P two blade – RH 14 D x 6 P three blade – RH <small>Propeller used must allow the engine to reach its rated rpm at full open throttle in forward gear, underway</small>
Lubricating Fluid	<i>ATF- type A or DEXTRON - II or III</i>
Transmission Sump Capacity	0.37 qts (0.35 liters)
Propeller Shaft Direction of Rotation	Right hand–standard transmission



11A-1 DIESEL ENGINE PARTS IDENTIFICATION

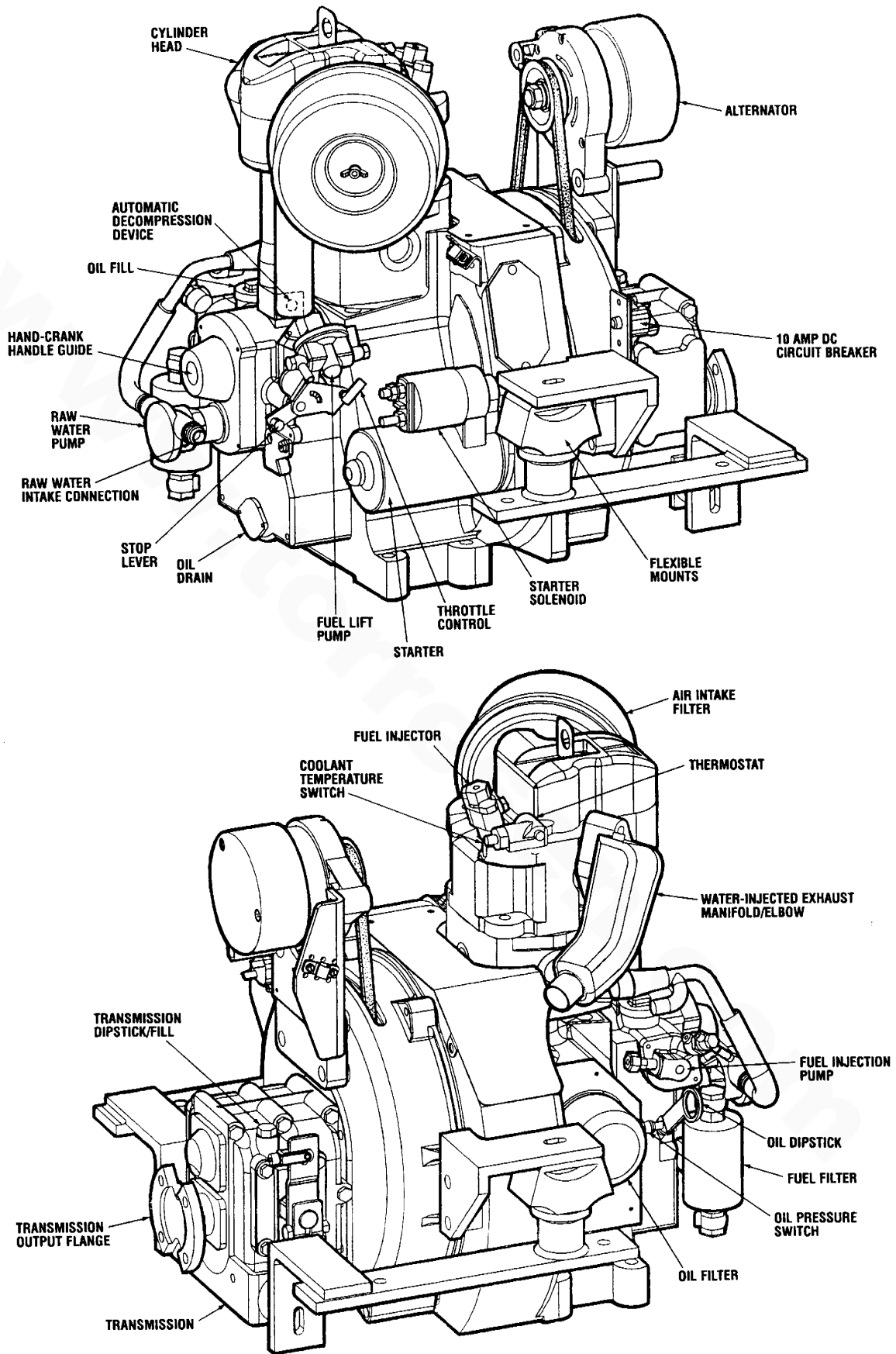

DIESEL FUEL

Use No. 2 diesel fuel with a cetane rating of 45 or higher. Do not use kerosene or home heating fuel.

Care of the Fuel Supply

Use only clean diesel fuel! The clearance of the components in your fuel injection pump is very critical; invisible dirt particles which might pass through the filter can damage these finely finished parts. It is important to buy clean fuel, and keep it clean. The best fuel can become unsatisfactory by careless handling or improper storage facilities. To assure that the fuel going into the tank for your engine's daily use is clean and pure, purchase a well-known brand of fuel. Also install and regularly service a good, Coast Guard approved fuel filter/water separator between the fuel tank and the engine.

Fuel Additives

If fungus or bacteria is causing fuel problems, you should have an authorized dealer correct these problems. Then use a diesel fuel biocide to sterilize the fuel (follow the manufacturer's instructions). Use a fuel stabilizer on a regular basis as well. STA-BIL is an example of such a product.

ENGINE OIL

CAUTION: *This engine was shipped from the factory without lubricant in the engine. Before operating, fill with the proper engine oil.*

Use an engine oil with an API classification of CF or CG-4. Change the engine oil after an initial 50 hours of break-in operation, and every 100 hours of operation thereafter. For recommended oil viscosity, see the following chart:

Operating Temperature	Oil Viscosity
Above 68° F (20° C)	SAE 30, 10W-30 or 15W-40
41° - 68° F (5° - 20° C)	SAE 20 or 10W-30
Below 41° F (5° C)	SAE 10W-30

CAUTION: *Do not allow two or more brands of engine oil to mix. Each brand contains its own additives; additives of different brands could react in the mixture to produce properties harmful to your engine.*

TRANSMISSION FLUID

Use ATF type A or Dextron II or III transmission lubricating fluid. The transmission sump capacity is 0.37 qts. (0.35 liters).

PRE-START INSPECTION

Before starting your engine for the first time, or after a prolonged lay-up, check the following items:

- Check the engine oil level. The oil level must be between the max. and min. marks on the dipstick.
- Turn on the fuel supply, then check the fuel supply and examine the fuel filter/water separator bowl for contaminants.
- Check the transmission fluid level.
- Check the DC electrical system. Inspect wire connections and battery cable connections. Make certain the positive (+) battery cable is connected to the starter solenoid and the negative (-) cable is connected to the engine ground stud (this location is tagged).
- Open the raw water intake and make sure the raw water supply reaches the raw water strainer.
- Visually examine the engine. Look for loose or missing parts, disconnected wires, and unattached hoses. Check the threaded connections. Check for fuel leaks.
- Make sure the exhaust system is secure and all the connections are tight.
- Make sure there is good ventilation and an ample air supply. These are necessary for proper engine performance.
- Make sure the mounting installation is secure.
- Make sure the propeller shaft is securely attached to the transmission.

ELECTRIC STARTING

The 7A-1/11A-1 diesel engine has a 12 VDC electric starter. The engine is started by using a keyswitch on the control panel. The switch has three positions: OFF, ON and START.

NOTE: Periodically lubricate the keyswitch mechanism with LOCKEZE to ensure proper keyswitch functioning.

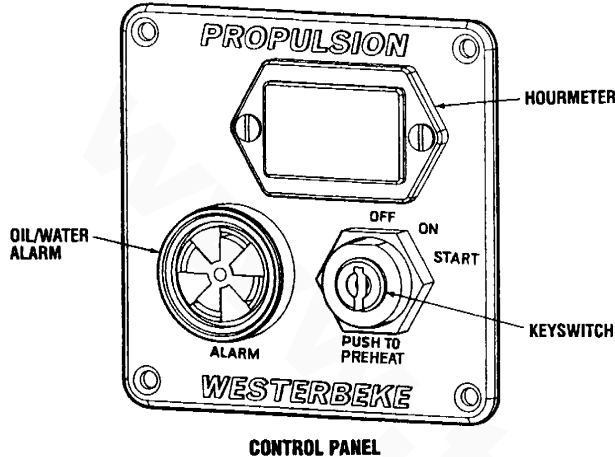

NOTE: The Automatic Decompression Device is *not* used for normal electric starting. During engine operation, the pointer on this device is in the operating (9 o'clock) position.

1. Place the transmission in neutral and advance the throttle control to slightly open.
2. Using a 10mm wrench, turn the hex-head bolt on the device so the pointer is in the *manual starting* position (see illustration).

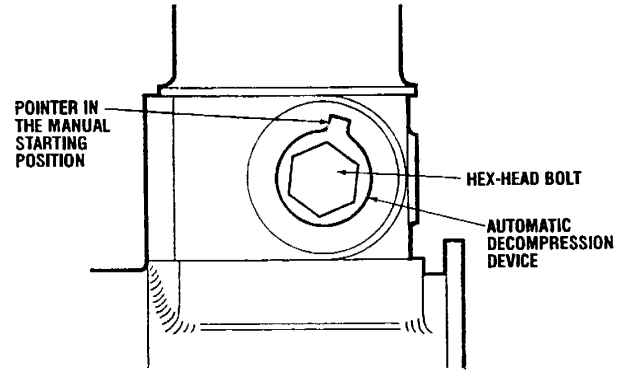

Electric Starting Procedure

1. Place the transmission in neutral and advance the throttle control to slightly open.

CAUTION: Make certain the transmission is in neutral. Starting in gear could result in serious damage to your transmission, your boat, and vessels nearby.

2. Turn the keyswitch to the ON position. The alarm buzzer on the control panel will beep. Push the key in to preheat. Hold the key in and turn it to the START position. When the engine starts, let go of the key and it will come out of preheat and spring back to the ON position (observe that it does this).

NOTE: If the engine doesn't start, limit each starting trial to 10 – 20 seconds. Wait for approx. 30 seconds before repeating the start. Never operate the starter motor while the engine is still running.

NOTE: Some unstable running may occur in a cold engine. This condition should smooth out as the normal operating temperature is reached and a load is applied. Allow a few minutes for the warm-up at a comfortable rpm (approximately 1,000 rpm), then reduce the rpm and get underway.

Low Battery Electric Starting Procedure

If the battery is discharged and too low for a normal electric start but not completely dead, an attempt at an electric start can be made by using the *Automatic Decompression Device*. This device works by holding the exhaust valve open, and is normally used when manually starting (hand-cranking) the engine.

3. Turn the keyswitch to the START position. The alarm on the control panel will beep until the engine oil pressure comes up. The pointer on the Automatic Decompression Device will automatically move clockwise with each crank. The pointer will stop at the 9 o'clock position and compression will occur after 8 cranks. Hold the keyswitch in the START position until either the engine starts or the pointer stops after the 8th crank. Then let go of the key and it will spring back to the ON position.

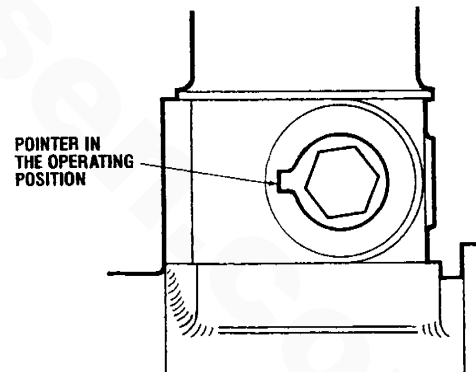

If this attempt at an electric start does not start the engine, then a manual start by hand-cranking will be necessary.

MANUAL STARTING (HAND CRANKING)

When installing the engine, it is important to provide enough space at the front end to allow for manual starting (hand cranking) in case of an emergency or when the starting battery has become too low to allow an electrical start.



STARTING/STOPPING PROCEDURE

The upper illustration shows the distance [4.5 in. (115 mm)] that the standard hand-crank handle protrudes from the crank-handle guide on the engine. An additional 2.5 in. (64 mm) *minimum* must be allowed for room to insert the handle.

If hand cranking must be done from outside the engine compartment (see lower illustration), then the standard hand-crank handle must be extended to the required length. This modification to the handle must be done by the owner.

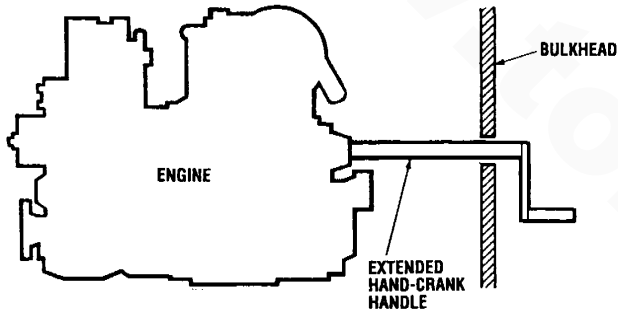
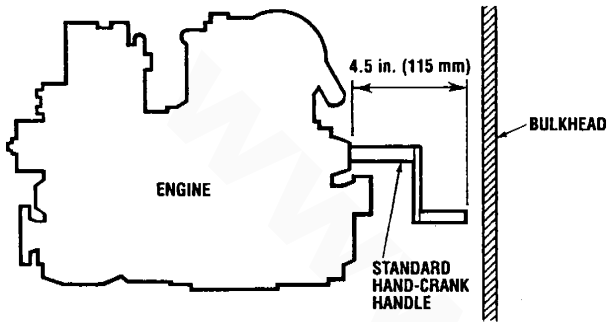

The engine may be started by hand-cranking in an emergency or when the starting battery has become too low to allow an electric start. A manual start is possible with a completely dead battery.

For easy and safe manual starting, the engine is fitted with an *Automatic Decompression Device* and a *Cold Starting Device*. Use both of these devices when hand-cranking.

Before using the hand-crank handle, an attempt at a normal electric start could be made by using the *Automatic Decompression Device* (see *Low Battery Electric Starting* under *ELECTRIC START*); the electrical power required for the start would then be considerably less, so that a discharged battery, if not completely dead, might allow the start.

NOTE: Oil will be supplied to all the bearing points when hand-cranking.

Automatic Decompression Device

The *Automatic Decompression Device* works by holding the exhaust valve open. The device has three positions, as indicated by the pointer. When setting the pointer, turn the hex-head bolt with a 10 mm wrench.

CAUTION: Never use the *Automatic Decompression Device* to stop the engine.

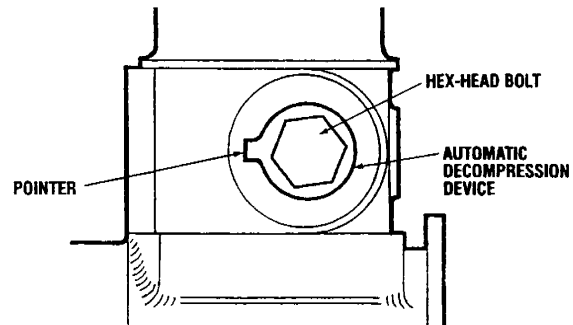

Cold Starting Device

This device provides more fuel from the injection pump. There are two positions for the knob: *up* (off) and *down* (activated).

When activating this device, pull the knob down (see illustration). To release this device, move the speed control lever down, then release it (see illustration).

NOTE: Never pull the *Cold Starting Device* knob down when the engine is operating or when restarting a hot engine.

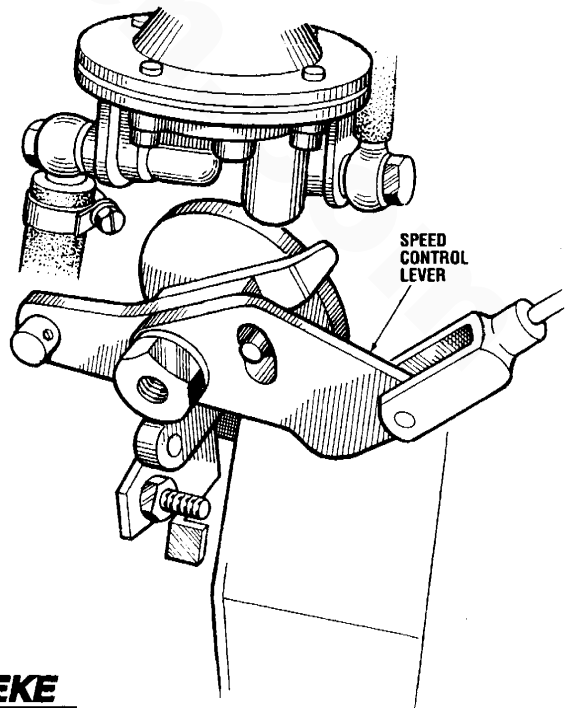
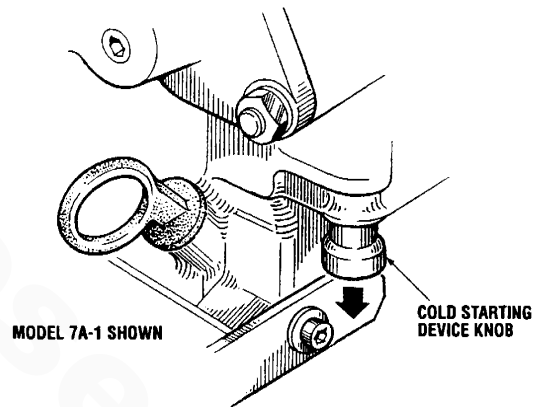

Manual Starting Procedure

To manually start the engine, follow the procedure described below. When starting after cold nights or freezing temperatures when the engine must first be turned over with no compression, follow all of the steps, beginning with Step 1. If cold weather is not a factor, bypass Steps 1—3, and begin with Step 4.

⚠ WARNING: Always keep hands and feet clear of moving parts. Put the transmission in neutral. Do not use starting aids.

1. Place the transmission in neutral and advance the throttle control to slightly open.

NOTE: Make sure the stop lever is in the RUN position.

2. Set the Automatic Decompression Device pointer to the Neutral position (see illustration). Compression is released when the pointer is in this position.

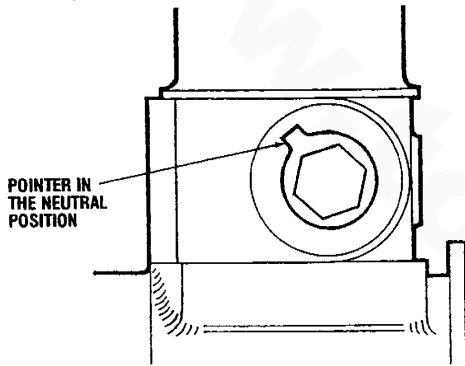

3. Insert the crank handle into the crank handle guide (see illustration). Standing to the right of the crank handle, put your right hand on top of the air intake filter for support and grip the crank handle with your left hand, with the thumb on your left hand in the position shown in the illustration.

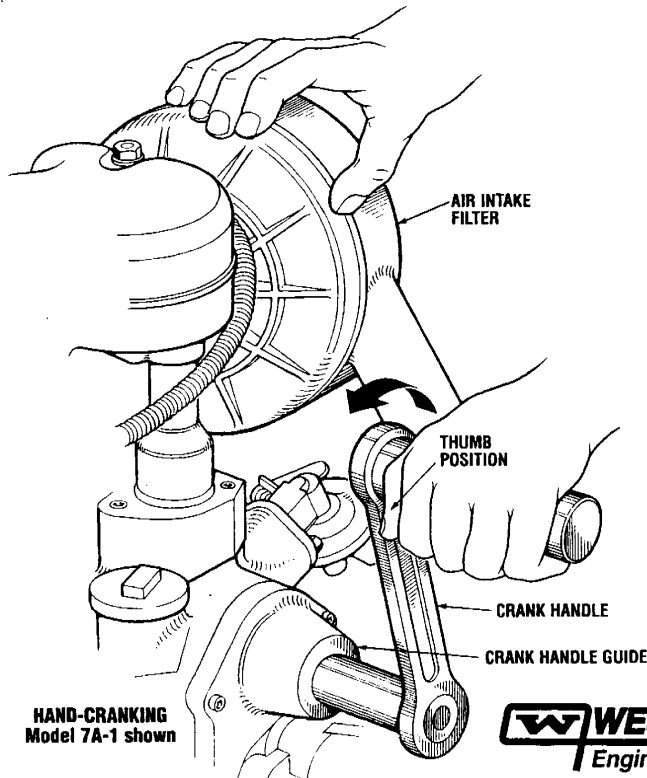

4. Crank the engine counterclockwise approximately 10 to 20 times until the engine turns freely. Then remove the crank handle.
5. Set the Automatic Decompression Device pointer to the manual starting position (see illustration). When hand-cranking in this position, automatic decompression will occur.

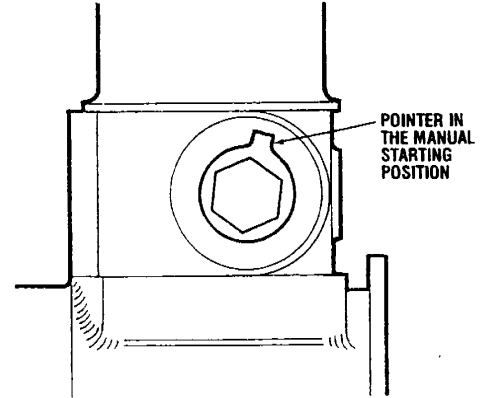

6. Pull down the Cold Starting Device knob. Note: Do not pull down this knob when restarting a hot engine.

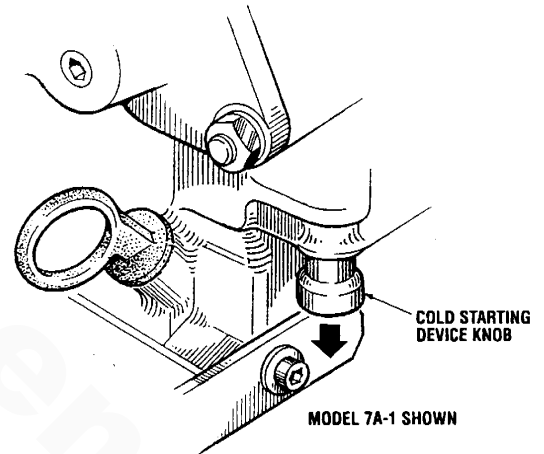

7. Insert the crank handle into the crank handle guide (see illustration). Standing to the right of the crank handle, put your right hand on top of the air intake silencer for support and grip the crank handle with your left hand, with the thumb on your left hand in the position shown in the illustration.
8. Slowly crank the engine counterclockwise 4 times, then crank the engine as fast as possible. The pointer on the Automatic Decompression Device will automatically move clockwise with each crank. Compression will occur after 8 cranks. Continue to crank after compression occurs until the engine starts firing. As decompression ends and compression occurs, the pointer will automatically stop at the operating (9 o'clock) position. After the engine starts, the crank handle will automatically disengage. Then remove the crank handle.



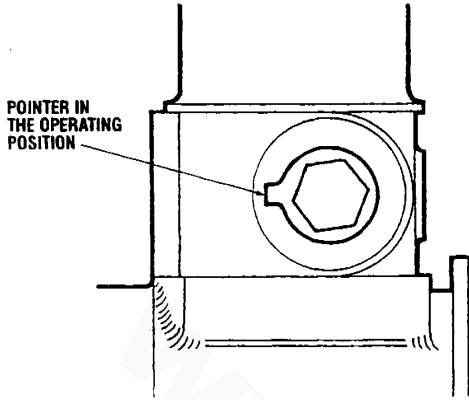

9. If the engine has not started, repeat Steps 5-9 above, and consider cranking at a higher speed.

CAUTION: Prolonged cranking intervals without the engine starting can result in the engine exhaust system filling with raw water. This may happen because the pump is pumping raw water through the raw water cooling system during cranking. This raw water can enter the engine's cylinder once the exhaust system fills. Prevent this from happening by closing the raw water supply through-hull shutoff, draining the exhaust muffler, and correcting the cause of the excessive engine cranking. Remember that engine damage resulting from raw water entry is not covered by Westerbeke's warranty.

Starting Under Cold Conditions

Make sure the lubricating oil is appropriate for the prevailing temperature. Use oil with an API Specification of CF or CG-4, SAE 30, 10W-30, or 15W-40. The battery should be fully charged to minimize voltage drop.

OPERATING THE ENGINE

Allow a few minutes for the engine to warm up at a comfortable rpm (approximately 1500 rpm), then reduce the rpm, and get underway.

CAUTION: Never pull the cold starting device knob down when the engine is operating.

Initial Start-Up Check List

- Check for possible leaks from all the connections.
- Make sure the cooling water is discharging properly, outboard from the exhaust outlet.
- Make certain that the engine is mounted securely.
- Listen for unusual sounds and vibrations.

STOPPING THE ENGINE

To stop the engine, bring the throttle to an idle position and place the transmission in neutral. Allow the engine to idle for a few moments to stabilize temperatures. Turn the engine off using the stop control cable, then turn off the keyswitch at the control panel.

NOTE: Make certain this keyswitch is in the OFF position (12 o'clock). If the keyswitch is left ON, the battery will discharge. An engine alarm is provided to warn the operator of this condition (key switch ON). The best method of preventing the battery from discharging is to remove the key from the keyswitch after stopping the engine.

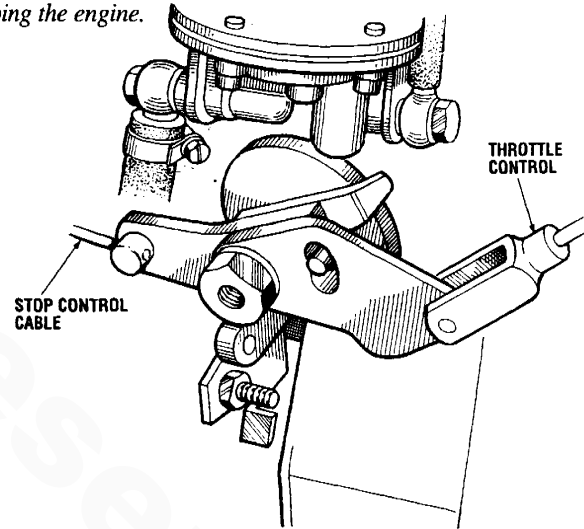

CAUTION: Never stop the engine with the automatic decompression device, or when the engine is under a full load.

Check the lube oil level a few minutes after stopping the engine, because lube oil from the bearings etc. continues to drain down into the oil sump. Disregarding this fact and not maintaining the proper oil level may lead to overfilling, causing overheating and the possibility of engine runaway.

After shutdown, carefully inspect the engine. Check for possible leaks from all the connections.

ENGINE BREAK-IN PROCEDURE

Although your engine has experienced a minimum of one hour of test operations at the factory to make sure accurate assembly procedures were followed and that the engine operated properly, a break-in time is required. The service life of your engine is dependent upon how the engine is operated and serviced during its initial 50 hours of use.

Breaking-in a new engine basically involves seating the piston rings to the cylinder walls. Excessive oil consumption and smoky operation indicate that the cylinder walls are scored, which is caused by overloading the engine during the break-in period.

Your new engine requires approximately 50 hours of initial conditioning operation to break-in each moving part in order to maximize the performance and service life of the engine. Perform this conditioning carefully, keeping in mind the following:

1. Start and stop the engine according to the *STARTING/STOPPING PROCEDURE* section. Run the engine at fast idle while checking that all systems are functioning.
2. Allow the engine to warm up, preferably by running at fast idle.

NOTE: *Some unstable running may occur in a cold engine. This condition should abate as normal operating temperature is reached and the propeller load is applied.*

3. While using the vessel, run the engine at various engine speeds for the first 25 hours. Avoid prolonged periods of idling.

4. Avoid rapid acceleration, especially with a *cold* engine.
5. Use caution not to overload the engine. The presence of a grey or black exhaust and the inability of the engine to reach its full rated speed are signs of an overload.
6. During the second 25 hours, the engine may be operated at varying engine speeds, with short runs at full rated rpm. Avoid prolonged idling during this break-in period.

Break-In Check List

Monitor the following during the 50 hour break-in period:

- Check for fuel, engine oil and water leaks.
- Check for abnormal noise such as knocking, friction, vibration and blow-back sounds.
- Confirm the exhaust smoke:
 - When the engine is cold – white smoke.
 - When the engine is warm – almost smokeless.
 - When the engine is overloaded – some black smoke and soot.

Also see the *DAILY OPERATION CHECKLIST* for additional items to check each day.

The *MAINTENANCE SCHEDULE* section gives the maintenance procedures to follow after the 50 hour break-in period.

Transmission Break-In

See the *HURTH HBW TRANSMISSION* section of this manual for break-in information on your transmission.

DAILY OPERATION

DAILY OPERATION

Start and stop the engine according to the instructions given in the *STARTING/STOPPING PROCEDURE* section. Also follow the instructions given in the *ENGINE BREAK-IN PROCEDURE* section during the first 50 hours of operation. Make sure all periodic maintenance is performed according to the *MAINTENANCE SCHEDULE*.

Daily Operation Check List

Follow this check list each day before starting your engine.

- Record the hourmeter reading in your log (engine hours relate to the maintenance schedule).
- Visually inspect the engine for fuel, oil or water leaks.
- Check the oil level (dipstick).
- Check the transmission fluid level.
- Check your diesel fuel supply.
- Look for clean fuel in the fuel filter/water separator transparent bowl.
- Check for loose wires at the alternator and make sure its mounting is secure.

- Check the starting batteries (weekly).
- Check drive belt for wear and proper tension (weekly).
- Check the raw water pump to make sure its mounting is secure.

After starting the engine, check the following:

- Check for abnormal noise such as knocking, vibration and blowby sounds.
- Confirm exhaust smoke:
 - When the engine is cold – white smoke.
 - When the engine is warm – almost smokeless.
 - When the engine is overloaded – some black smoke and soot.
- Make sure the cooling water is discharging properly, outboard from the exhaust outlet.

Transmission

See *DAILY OPERATION* in the *HURTH HBW TRANSMISSION* section.



Engine parts from Torrsen Marine - www.torresen.com - 231-759-8596

MAINTENANCE SCHEDULE

In order to use this Maintenance Schedule, it will be necessary to log your engine hours. Use your engine hourmeter or record your engine hours by running time.

NOTE: Many of the following maintenance procedures are simple but others are more difficult and may require the expert knowledge of a service mechanic.

⚠ WARNING: Never attempt to perform any service while the engine is running. Wear the proper safety equipment such as goggles and gloves, and use the correct tools for each job. Disconnect the battery terminals when servicing any of the engine's DC electrical equipment.

COMPONENT	MAINTENANCE FREQUENCY								MAINTENANCE DESCRIPTION
	AFTER FIRST 50 HOURS	DAILY OR EVERY 8 HOURS	WEEKLY	EVERY 100 HOURS	EVERY 300 HOURS	EVERY 600 HOURS	EVERY 1000 HOURS	EVERY 2000 HOURS	
Engine oil level		■							Oil level should be between the full and low indicating marks on the dipstick. Top up if necessary.
Engine oil change	■			■					Change the oil: see <i>CHANGING THE OIL</i> under <i>LUBRICATION SYSTEM</i>
Crankcase oil and strainer						■			Remove the oil strainer and clean it with diesel fuel. Flush the crankcase with the proper lube oil.
Fuel supply		■							Check the fuel supply. Top up if necessary.
Fuel filter/water separator		■		■					Check for water and dirt in the fuel. Drain and replace the filter if necessary.
Fuel lift pump						■			Clean or replace the two filters. See <i>FUEL LIFT PUMP</i> under <i>FUEL SYSTEM</i> .
Fuel filter				■					Change the filter.
Fuel injector*						■			Check and adjust the injection opening pressure and spray condition (see <i>TESTING THE FUEL INJECTOR</i> under <i>ENGINE ADJUSTMENTS</i>).
Raw water pump						■			Remove the pump cover and inspect the impeller, gasket, cam and cover for wear. Check the bearings and seals (the shaft can turn, but not wobble). Lubricate when reassembling.
Raw water intake strainer				■					See <i>RAW WATER INTAKE STRAINER</i> under <i>COOLING SYSTEM</i> .
Thermostat								■	Check the functioning of the thermostat; see <i>THERMOSTAT</i> under <i>COOLING SYSTEM</i> .
Engine hoses			■						Hoses should be hard and tight. Replace if soft and spongy. Check and tighten all hose clamps.
Air intake filter				■					Clean.
Exhaust system*	■		■		■				Inspect for leaks. Check the anti-siphon valve operation. Check that all connections are tight. Check the exhaust manifold/exhaust elbow for carbon and/or corrosion buildup on inside passages; clean and replace as necessary. Warning: A defective exhaust manifold/exhaust elbow can cause carbon monoxide leakage!
Starting batteries and house batteries			■						Check electrolyte levels and make sure connections are very tight. Clean off excessive corrosion.
DC Alternator					■				Check the DC charge from the alternator. Check mounting bracket; tighten electrical connections.

*Westerbeke recommends that this service be performed by an authorized mechanic.

(continued)



MAINTENANCE SCHEDULE

COMPONENT	MAINTENANCE FREQUENCY								MAINTENANCE DESCRIPTION
	AFTER FIRST 50 HOURS	DAILY OR EVERY 8 HOURS	WEEKLY	EVERY 100 HOURS	EVERY 300 HOURS	EVERY 600 HOURS	EVERY 1000 HOURS	EVERY 2000 HOURS	
Drive belt			■						Inspect for proper tension: 3/8 – 1/2 in. (10 – 12 mm) deflection, and adjust if necessary. Check belt edges for wear (see <i>DRIVE BELT ADJUSTMENT</i> under <i>ENGINE ADJUSTMENTS</i>).
Starter motor*						■			Check the solenoid and motor for corrosion. Remove and lubricate. Clean and lubricate the starter motor pinion drive.
Adjust engine idle speed	■								Adjust to 1000 – 1200 rpm.
Valve clearances*	■					■			Adjust the valve clearances – see <i>VALVE CLEARANCE ADJUSTMENT</i> under <i>ENGINE ADJUSTMENTS</i> .
Cylinder compression*						■			Check the compression pressure – see <i>ENGINE COMPRESSION TEST</i> under <i>ENGINE ADJUSTMENTS</i> .
Cylinder head nuts	■					■			Retorque the nuts (see <i>TIGHTENING THE CYLINDER HEAD</i> under <i>ENGINE ADJUSTMENTS</i>).
Transmission fluid level					■				Initial fluid change at 25 hours, then every 300 hours or at winterizing.
Engine transmission damper plate							■		Chattering at idle and low rpms is an indication of damper plate wear. Remove and replace.
Throttle and transmission control cable	■				■				Check for loose fittings, cotter pins, etc. Lubricate with <i>WD-40</i> or equivalent.
Visual inspection		■							Check for oil, fuel and water leaks.
Hardware fastenings and electrical connections	■			■					Inspect and tighten all fastenings and accessible screws, bolts and nuts. Inspect all wiring and electrical connections.
Cleaning the engine			■						Keep the engine's surface clean. Surface dirt and oil will inhibit the engine's ability to remain cool.
Lubricate control panel keyswitch				■					Lubricate with <i>LOCKEZE</i> or equivalent every 100 hours or at winterizing. After lubricating, check for smooth operating of the switch.

*Westerbeke recommends that this service be performed by an authorized mechanic.



DESCRIPTION

It is important to install a proper exhaust system to avoid engine flooding. The system must be designed to prevent water from entering the exhaust line under any sea conditions and at any angle of the vessel's hull. Exhaust system failures are not covered by Westerbeke's warranty. The installer should have a basic knowledge of marine installation requirements.

Westerbeke recommends installing an exhaust system having an in-line muffler. The in-line muffler should be located below the engine's exhaust elbow. It must accumulate any water that runs back down the exhaust line after the engine is shut down. Design the system so there is an adequate drop in the line between the exhaust elbow and the through-hull discharge end of the line. The exhaust hose must be certified for marine use.

CAUTION: *An exhaust line that is too long and/or has a poor gradient can cause water to return back to the engine when it is shut off.*

WARNING: *The exhaust system must be tight and free of leaks. Exhaust gasses are deadly. Display the Carbon Monoxide warning decal near your engine, on your cabin bulkhead, or in some other prominent location.*

For more information about exhaust system design, see Westerbeke's *INSTALLATION MANUAL for MARINE ENGINES and GENERATORS*, Publication # 43268.

Westerbeke presumes that the installer of this marine diesel engine is familiar with the safeguards a water-cooled marine exhaust system will provide for the engine. Failure to design and layout a proper exhaust system can result in catastrophic damage to the diesel engine, and possibly result in the sinking of the vessel in which the unit is installed.

Siphon-Break

For installations where the water-injected exhaust elbow is close to or below the vessel's waterline, provisions must be made to install a siphon-break in the raw water supply hose to the exhaust elbow. The siphon-break provides an air vent in the raw water cooling system to prevent raw water from filling the exhaust system and the engine's cylinder when the engine is shut down. See *SIPHON-BREAK* in the *COOLING SYSTEM* section for more information.

CAUTION: *Failure to use a siphon-break when the exhaust elbow is located at or below the load waterline will result in raw water damage to the engine and possible flooding of the boat.*

EXHAUST SYSTEM PRECAUTIONS

Carbon Monoxide

The best protection against carbon monoxide poisoning is a daily inspection of the complete exhaust system. Check for leaks around the exhaust manifold/elbow, exhaust hose, gaskets, and welds. Make sure there are no fumes entering your boat from a nearby vessel. Make sure the exhaust lines are not heating the surrounding areas excessively. If excessive heat is present, correct the situation immediately. If you notice a change in the sound or appearance of the exhaust system, shut down the engine immediately and have the exhaust system inspected and repaired at once by a qualified mechanic.

WARNING: *Exhaust gasses contain Carbon Monoxide, an odorless and colorless gas. Carbon Monoxide is poisonous and can cause unconsciousness and death. Symptoms of Carbon Monoxide exposure can include:*

- Dizziness
- Nausea
- Headache
- Vomiting
- Throbbing in Temples
- Muscular Twitching
- Weakness and Sleepiness
- Inability to Think Coherently

IF YOU OR ANYONE ELSE EXPERIENCE ANY OF THESE SYMPTOMS, GET OUT INTO FRESH AIR IMMEDIATELY. If the symptoms persist, seek medical attention. Shut down the engine and ventilate the area with clean air. Do not restart the engine until it has been inspected and repaired.

Carbon Monoxide Warning Decal

A carbon monoxide warning decal has been provided by Westerbeke. Display this decal near your engine, on your cabin bulkhead, or in some other prominent location.



**CARBON MONOXIDE
WARNING DECAL**

Carbon Monoxide Detectors

It is extremely important that a carbon monoxide detector(s) be installed in your boat's living and/or sleeping quarters. Make sure it is manufactured for the marine industry. They are inexpensive and available at your marine supplier.

Insulation

Inspect insulated portions of the exhaust system to ensure there is no deterioration of the insulation.

Overcranking

⚠ CAUTION: *Prolonged cranking intervals without the engine starting can result in the engine exhaust system filling with raw water. This may happen because the pump is pumping raw water through the raw water cooling system during cranking. This raw water can enter the engine's cylinder once the exhaust system fills. Prevent this from happening by closing the raw water supply through-hull shutoff, draining the exhaust muffler, and correcting the cause of the excessive engine cranking. Remember that engine damage resulting from raw water entry is not covered by Westerbeke's warranty.*

DESCRIPTION

The lubricating system is a pressure feeding system using an oil pump. The engine oil is drawn from the oil sump by the oil pump, which drives the oil, under pressure, through the various lubricating points in the engine. The oil then returns to the oil sump to repeat the continuous cycle.

The gear-driven oil pump is built into the oil sump. The oil is pumped through a spin-on type oil filter (Model 11A-1 only) to the main bearing and connecting rod bearing. The piston, cylinder liner and rocker arms are splash-lubricated. There is an oil strainer in the crankcase (see *Crankcase/Oil Strainer* in the *MAINTENANCE SCHEDULE* for maintenance information. A crankcase breather valve is integrated into the cylinder head's inlet channel and is maintenance-free.

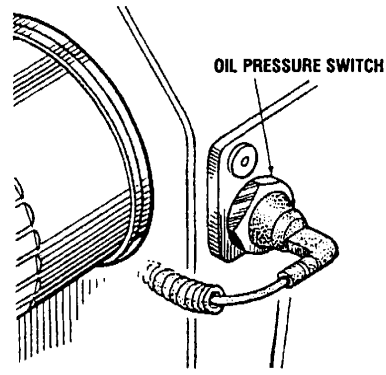

OIL PRESSURE SWITCH
Model 11A-1 shown

ENGINE OIL

Use a heavy duty engine oil with an API classification of CF or CG-4 or better. The SAE grade depends on the ambient temperature. For the recommended oil viscosity, see the following chart:

Operating Temperature	Oil Viscosity
Above 68° F (20° C)	SAE 30, 10W-30 or 15W-40
41° - 68° F (5° - 20° C)	SAE 20 or 10W-30
Below 41° F (5° C)	SAE 10W-30

CAUTION: Do not allow two or more brands of engine oil to mix. Each brand contains its own additives; additives of different brands could react in the mixture to produce properties harmful to your engine.

CHECKING THE OIL

Check the lube oil level (see illustration) prior to starting. With continuous operation, check the oil level daily or every 8 hours.

Check the lube oil level a few minutes after stopping the engine because lube oil from the bearings etc. continues to drain down into the oil sump. Disregarding this fact and not maintaining the proper oil level may lead to overfilling, overheating and engine runaway.

If a top-up is necessary, clean the area around the oil filler to prevent dirt from entering the engine.

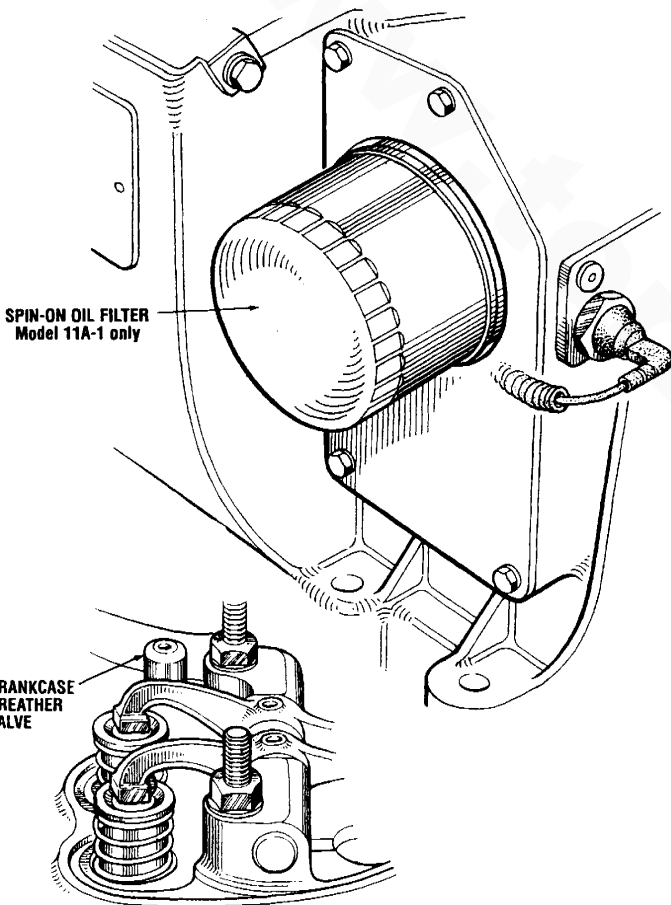

SPIN-ON OIL FILTER
Model 11A-1 only

CRANKCASE BREATHER VALVE

Oil Pressure Relief Valve

There is an oil pressure relief valve in the sump. If the oil pressure exceeds the maximum specified value, the valve opens and some of the oil returns to the sump, keeping the oil pressure below its maximum specified value.

Low Oil Pressure Alarm Switch

A low oil pressure alarm switch is located on the engine block. This switch's sensor monitors the engine's oil pressure. Should the engine's oil pressure fall below the specified value, this switch will activate a pulsating alarm on the control panel.

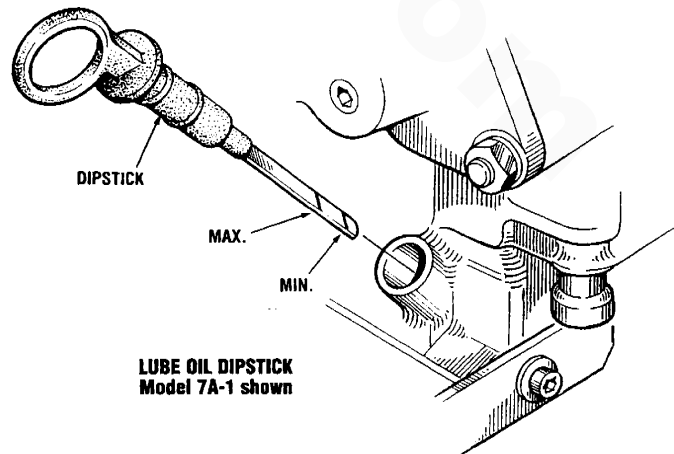

DIPSTICK

MAX.

MIN.

LUBE OIL DIPSTICK
Model 7A-1 shown



CHANGING THE OIL

Change the oil after an initial 50 hours of break-in operation and every 100 hours of operation thereafter. Change the oil only when the engine is warm.

Always observe the used oil as it is removed. A yellow/gray emulsion indicates the presence of water in the oil. Although this condition is rare, it does require prompt attention to prevent serious damage. Call a qualified mechanic should water be present in the oil. Raw water present in the oil can be the result of a fault in the exhaust system attached to the engine and/or a siphoning of raw water through the raw water cooling circuit into the exhaust, filling the engine. This problem is often caused by the absence of an anti-siphon valve, its poor location or lack of maintenance.

CAUTION: *Used engine oil contains harmful contaminants. Avoid prolonged skin contact. Clean skin and nails thoroughly using soap and water. Launder or discard clothing or rags containing used oil. Discard used oil properly.*

Removing the Old Oil

1. Remove the oil filler cap (see illustration) using a 13 mm open end spanner.

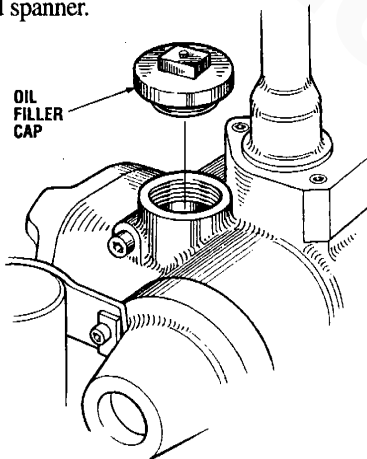

2. **Model 7A-1:** Place a suitable container below the oil drain plug (see illustration), then remove the oil drain plug and completely drain the used oil into the container. Then remove and clean the lube oil strainer. Always clean this strainer at every oil change. After cleaning, replace the strainer and the oil drain plug.

Model 11A-1: Place a suitable container below the oil drain cover plate (see illustration), then remove the cover plate and completely drain the used oil into the container. Then replace the cover plate. **NOTE:** Be sure to change the spin-on oil filter at every oil change (see *Changing the Spin-On Oil Filter*, below).

NOTE: *With an inclined engine installation, the lube oil must be pumped out, otherwise too much oil would remain in the crankcase.*

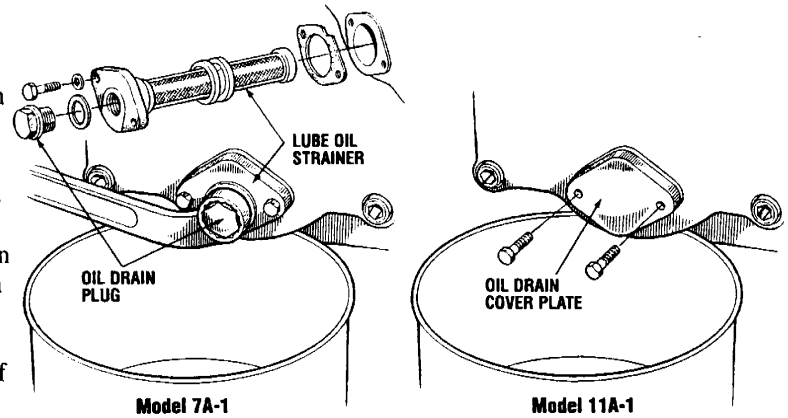

REMOVING THE OLD OIL

Changing the Oil Filter (Model 11A-1 only)

When removing the used oil filter, you may find it helpful, and cleaner, to punch a hole in the upper and lower portion of the old filter to drain the oil from it into a container before removing it. This helps to lessen spillage. A small automotive filter wrench should be helpful in removing the old oil filter.

NOTE: *Do not punch this hole without first loosening the filter to make certain it can be removed.*

Place some paper towels and a plastic bag around the filter when unscrewing it to catch any oil left in the filter. (Oil or any other fluid on the engine reduces the engine's cooling ability. Keep your engine clean.) Inspect the old oil filter as it is removed to make sure that the rubber sealing gasket comes off with the old oil filter. If this rubber sealing gasket remains sealed against the filter bracket, gently remove it.

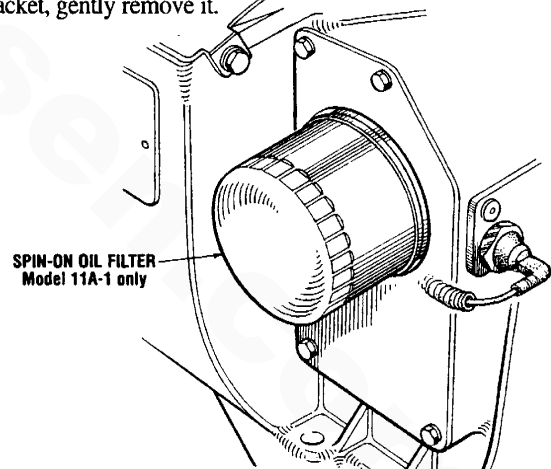

When installing the new oil filter element, wipe the filter gasket's sealing surface on the bracket free of oil and apply a thin coat of clean engine oil to the rubber gasket on the new oil filter. Screw the filter onto the threaded oil filter nipple and then tighten the filter firmly by hand.

NOTE: *Generic filters are not recommended, as the material standards or diameters of important items on generic parts might be entirely different from genuine parts. Immediately after an oil filter change and oil fill, run the engine to make sure the oil pressure is normal and that there are no oil leaks around the new oil filter.*

Adding the New Oil

1. Add the new oil through the oil fill.
2. Replace the oil filler cap. When tightening it, do not use too much force otherwise the plastic plug may break.
3. After refilling with new oil, run the engine for a few moments. Make sure there is no leakage around the oil filler cap or the new oil filter (Model 11A-1 only), then stop the engine. Then check the quantity of oil with the lube oil dipstick. Fill to, but not over the MAX mark on the dipstick, should the engine require additional oil.

TESTING THE OIL PRESSURE

Before testing, make sure the oil level is at the MAX mark on the dipstick.

1. Remove the oil pressure switch (see illustration).

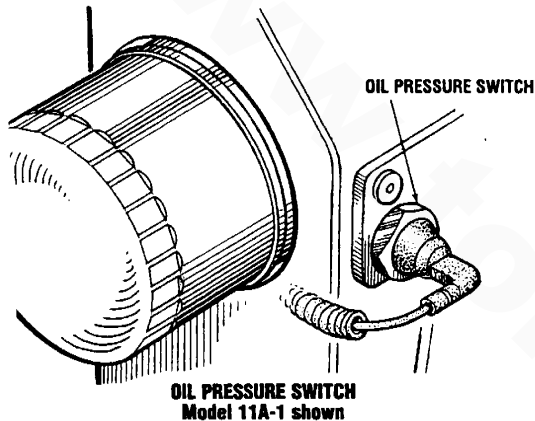

2. Install a mechanical oil pressure gauge in the oil pressure switch hole.
3. Warm up the engine, then set the engine speed at 3000 rpm, and read the gauge.

Operating oil pressure (engine hot):
25.6 – 56.9 psi (1.8 – 4.0 kg/cm²)

If the oil pressure is too low, see *Low Oil Pressure* under **ENGINE TROUBLESHOOTING**.

NOTE: The oil pressure switch closes at 4.3 – 8.7 psi (0.3 – 0.6 Bar).

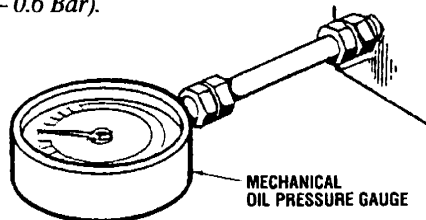

RAW WATER COOLING SYSTEM

The engine is designed for direct raw water cooling. The engine operates with a raw water coolant temperature up to 90° F (32° C).

The raw water flow is created by a positive displacement impeller pump that is gear-driven by the camshaft. This pump draws cooling water directly from the raw water source (ocean, lake or river) through a hose.

The raw water is pumped through a tee which splits the flow. The tee directs some of the flow to passages in the engine block and the remainder to a bypass. The flow to the engine block circulates around the cylinder and through the cylinder head, cooling the engine. The flow through the bypass goes directly to the exhaust manifold/elbow, and is at its greatest when the engine is warming up and the thermostat is not yet open. Flow through the bypass also occurs after the thermostat is open. The raw water that is flowing through the engine block then flows through the thermostat to the exhaust manifold/elbow where it mixes with and cools the exhaust gases. This mixture of exhaust gas and raw water is discharged overboard by the engine's exhaust gas discharge pressure.

The coolant temperature switch is located on the cylinder head for Model 7A-1, and on the thermostat housing for Model 11A-1.

THERMOSTAT

A thermostat, located on top of the cylinder head, controls the raw water coolant temperature as the coolant flows through the cooling system. The thermostat is set to the maximum temperature of 140° F (60° C). When the engine is first started, the closed thermostat prevents coolant from flowing (some coolant is by-passed through a bypass tube to prevent the exhaust manifold from overheating). As the engine warms up, the thermostat gradually opens. The thermostat is accessible and can be checked, cleaned, or replaced easily. Carry a spare thermostat and gasket.

Checking/Replacing the Thermostat

Remove the two cap screws and the thermostat housing, then remove the thermostat from the cylinder head (see illustration).

To check the thermostat, immerse it in water that is approximately 140° F (60° C). The thermostat's cone must then be fully open – this indicates the thermostat is in good condition.

Use a new gasket when reinstalling the thermostat or replacing it. Apply a thin coat of sealant on both sides of the gasket before pressing it into place. Do *not* over-tighten the cap screws.

Run the engine and check for normal temperatures and that there are no leaks at the thermostat housing.

COOLANT TEMPERATURE SWITCH

The coolant temperature switch is located near the thermostat housing (see illustration). If the coolant's operating temperature reaches approximately 175° F (80° C) this switch will activate the alarm on the control panel.

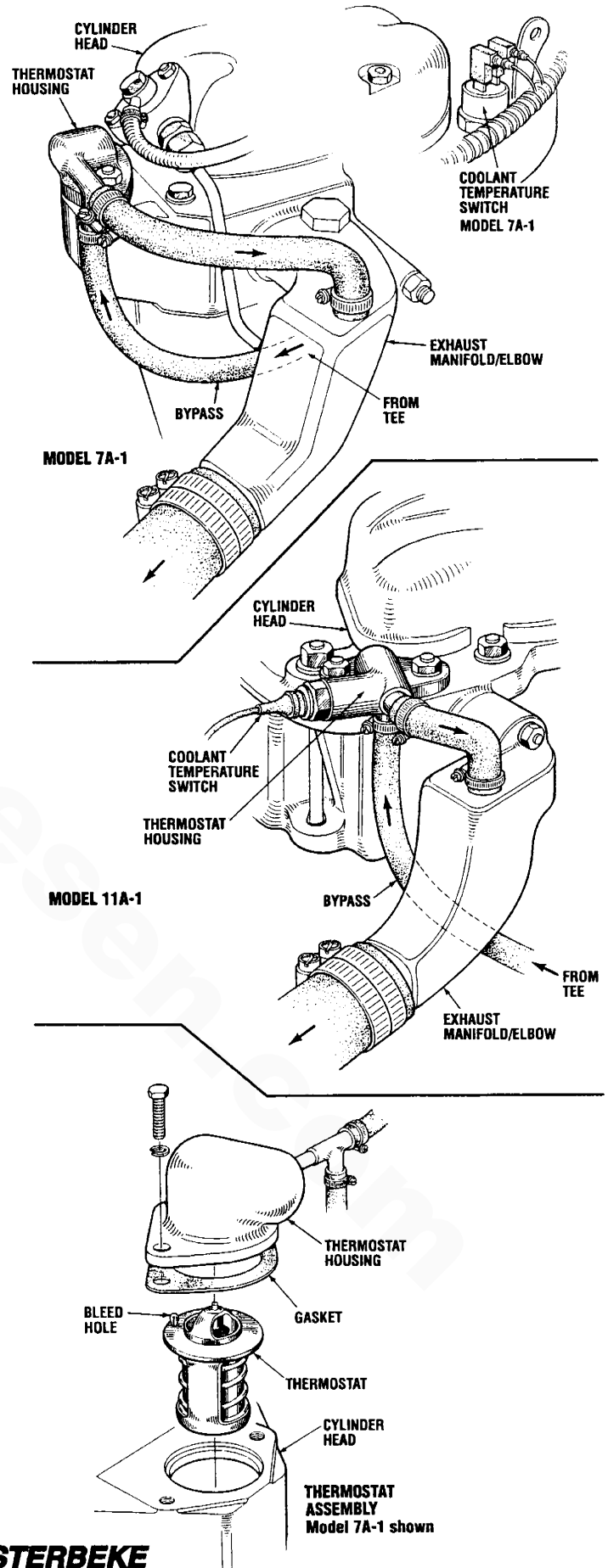

RAW WATER PUMP

The raw water pump is a self-priming, rotary pump with a non-ferrous housing and a neoprene impeller. The impeller has flexible vanes which wipe against a curved cam plate within the impeller housing, producing the pumping action. On no account should this pump be run dry as water acts as a lubricant for the impeller. There should always be a spare impeller and impeller cover gasket (an impeller kit) onboard. Raw water pump impeller failures occur when lubricant (raw water) is not present during engine operation. Such failures are not warrantable and operators are cautioned to make sure raw water flow is present at start-up. The neoprene impeller has a limited lifetime and must be inspected regularly.

NOTE: Should a failure occur with the pump's internal parts (seals and bearings), it may be more cost effective to purchase a new pump and rebuild the original pump as a spare.

Inspecting/Changing the Raw Water Pump Impeller

Close the raw water intake valve. Remove the pump cover and, with the aid of two small screwdrivers, carefully pry the impeller out of the pump. Install the new impeller and gasket. Move the blades to conform to the curved cam plate and push the impeller into the pump's housing. When assembling, apply a thin coating of lubricant to the impeller and gasket. Open the raw water intake valve.

NOTE: Never allow the pump to run dry. Even a short period of dry running may destroy the impeller.

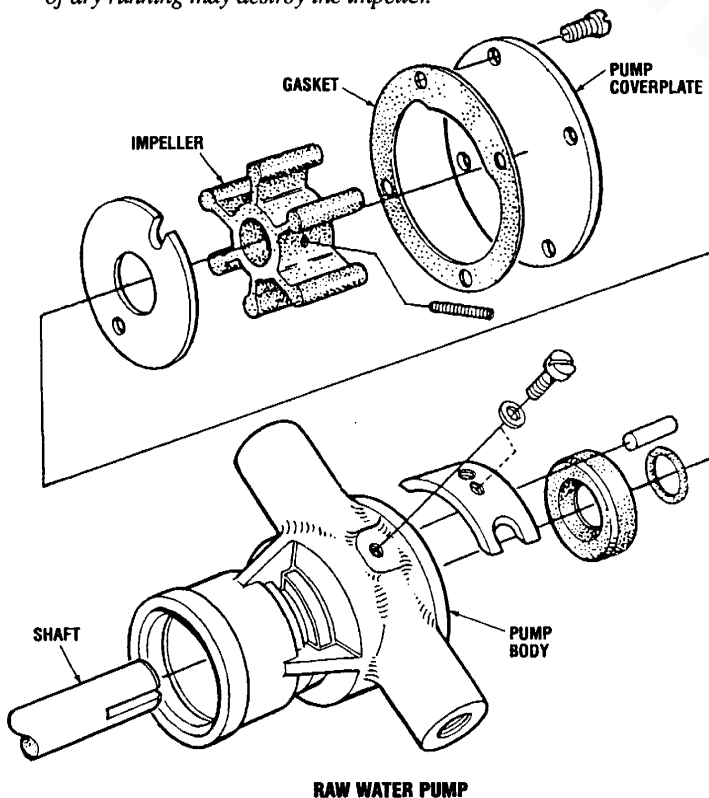

RAW WATER INTAKE

A flush-type through-hull fitting is recommended for the raw water intake. It should be located on the boat's hull where it will be below the waterline during all angles of the boat's operation. See Westerbeke's *INSTALLATION MANUAL for MARINE ENGINES and GENERATORS* for complete installation guidelines.

WARNING: Do not use a scoop-type through-hull fitting for supplying raw water to this engine. A scoop-type raw water inlet can develop substantial pressure and force water past the raw water pump, flooding the exhaust system and allowing the water to enter the engine's cylinder. Damage caused by raw water entry into the engine's cylinder via the exhaust system is not covered by Westerbeke's warranty.

Flooding of the exhaust system due to water pressure can also occur with a flush-type raw water intake on a powerboat that has its bow up. This pressure can be caused by the boat's decreased waterline before the boat reaches its final trim, or by the angle of the boat to the sea surface when it is underway.

RAW WATER INTAKE STRAINER

NOTE: Always install the strainer at or below the waterline so the strainer will always be self-priming.

A clean raw water intake strainer is a vital component of the engine's cooling system. Include a visual inspection of this strainer when making your periodic engine check. The water in the glass should be clear.

Perform the following maintenance after every 100 hours of operation:

1. Close the raw water seacock.
2. Remove and clean the strainer filter.
3. Clean the glass.
4. Replace the sealing washer if necessary.
5. Reassemble and install the strainer.
6. Open the seacock.
7. Run the engine and check for leaks.

NOTE: Also follow the above procedure after having run hard aground.

If the engine is indicating higher than normal operating temperatures (i.e the alarm is sounding), the cause may be that silt, leaves or grass may have been caught up in the strainer, slowing the flow of raw water through the cooling system.

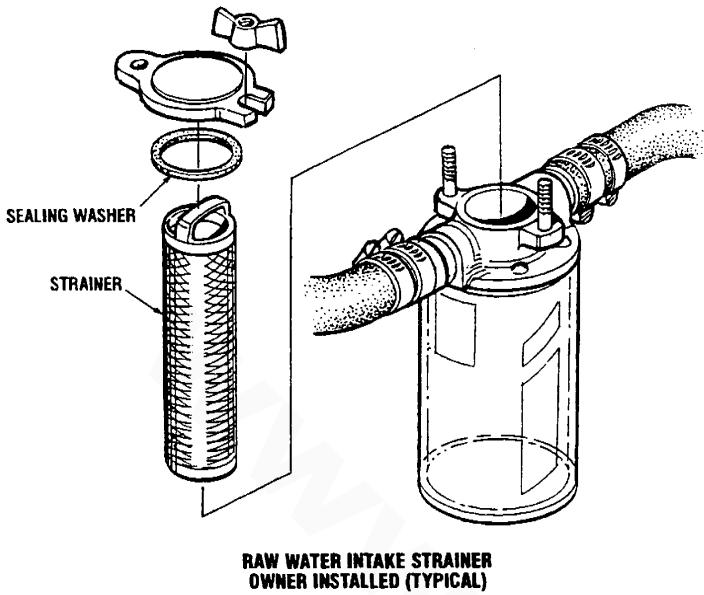

SIPHON-BREAK

For installations where the water-injected exhaust elbow is close to or below the vessel's waterline, provisions must be made to install a siphon-break in the raw water supply hose to the exhaust elbow. The siphon-break provides an air vent in the raw water cooling system to prevent raw water from filling the exhaust system and the engine's cylinder when the engine is shut down.

CAUTION: Failure to use a siphon-break when the exhaust elbow is located at or below the load waterline will result in raw water damage to the engine and possible flooding of the boat.

If you have any doubt about the position of the water-injected exhaust elbow relative to the vessel's waterline under any of the vessel's various operating conditions or when the vessel is not under way, *install a siphon-break*. This precaution is necessary to protect your engine.

The siphon-break must be installed in the high point of a hose that is looped a minimum of 20 inches (51 cm) above the vessel's waterline. This siphon-break *must always* be above the waterline during all angles of vessel operation to prevent siphoning from occurring. WESTERBEKE has provided two siphon-break hoses (these are tagged). The hose *to* the siphon-break connects to the raw water line at the thermostat housing. The hose *from* the siphon-break attaches to the water-injected exhaust elbow (see illustration). The owner must furnish the siphon-break, and any additional lengths of hose that may be required.

NOTE: A siphon-break requires periodic inspection and cleaning to ensure proper operation. Failure to properly maintain a siphon-break can result in severe engine damage. Consult the siphon-break manufacturer for a proper maintenance schedule.

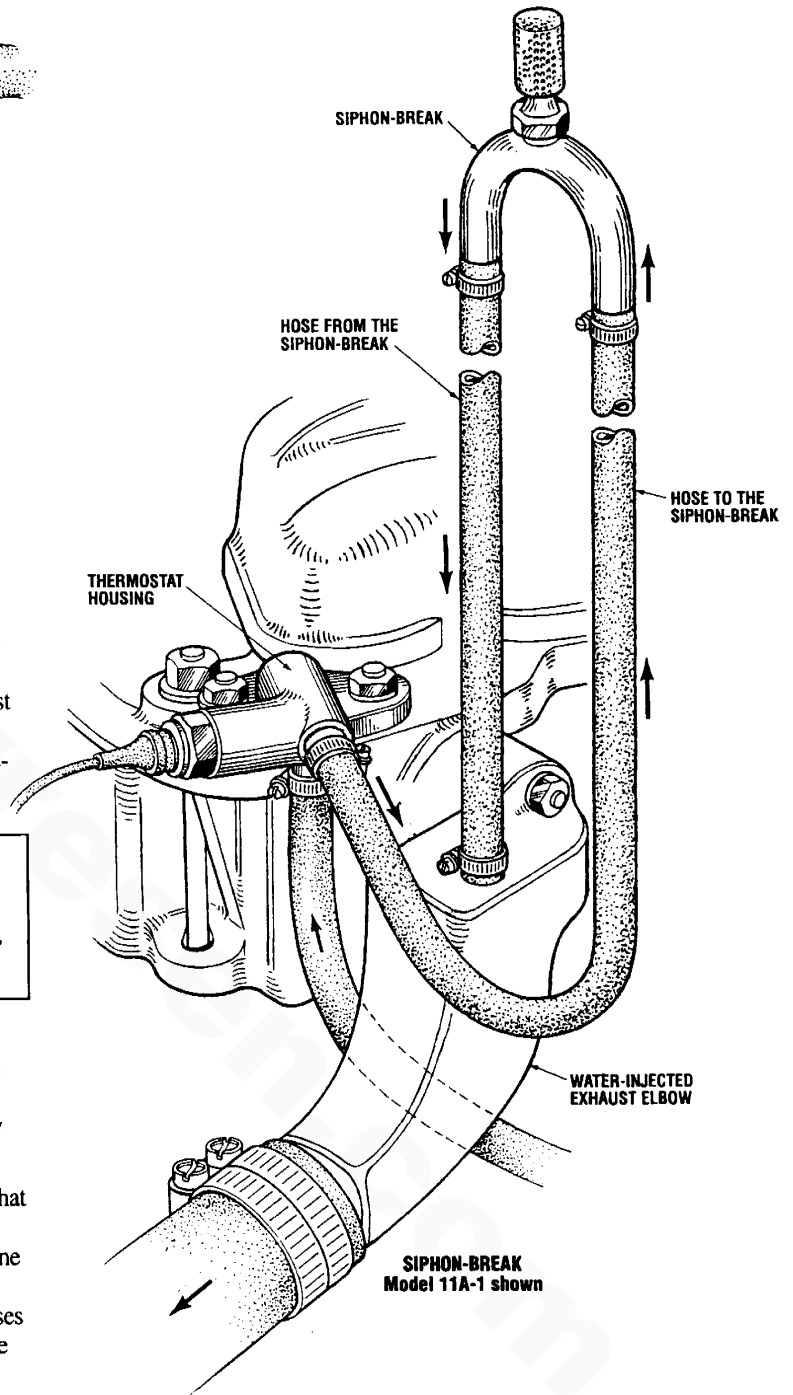

DRAINING THE COOLING SYSTEM

When freezing temperatures are expected, the cooling system can be drained by unscrewing the pump cover. The raw water coolant will then flush back down the inlet line.



AIR INTAKE FILTER

DESCRIPTION

The 7A-1 and 11A-1 marine diesel engines, when operating in the cruise rpm range, will typically consume in excess of 1000 cubic feet of air per hour. The engine compartment must be well ventilated, and the air flow into the engine must be unrestricted.

Air Filter

The air filter cartridge prevents dust and dirt from entering the engine; it also improves oil consumption, extends engine life, and quiets the engine.

Maintenance

The filter should be cleaned every 100 operating hours. Tap the cartridge on a flat surface to dislodge loose dirt or clean it off with compressed air. If the cartridge is badly contaminated or oily, replace it.

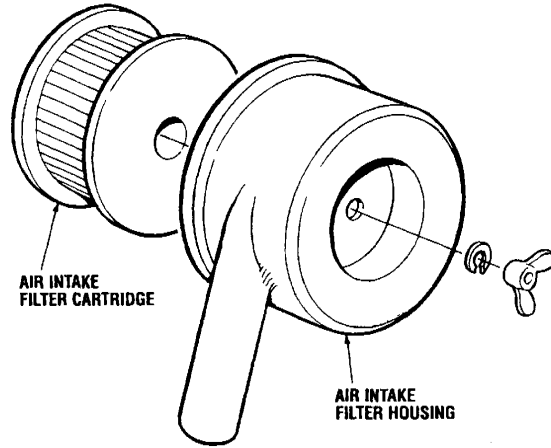

WATER HEATER

WATER HEATER INSTALLATIONS

This engine is equipped with connections for plumbing the engine coolant to transfer heat to an on-board water heater. The water heater should be mounted in a convenient location either in a low or high position in relation to the engine.

Plumb the heater hoses into the raw water line that connects the thermostat housing to the exhaust manifold/elbow (see illustration).

NOTE: If the exhaust manifold/elbow on your engine is close to or below the vessel's waterline, you must also install a siphon-break on the same hose (see Siphon-Break under RAW WATER COOLING SYSTEM for more information). The water heater connections may be located either before or after the siphon-break.

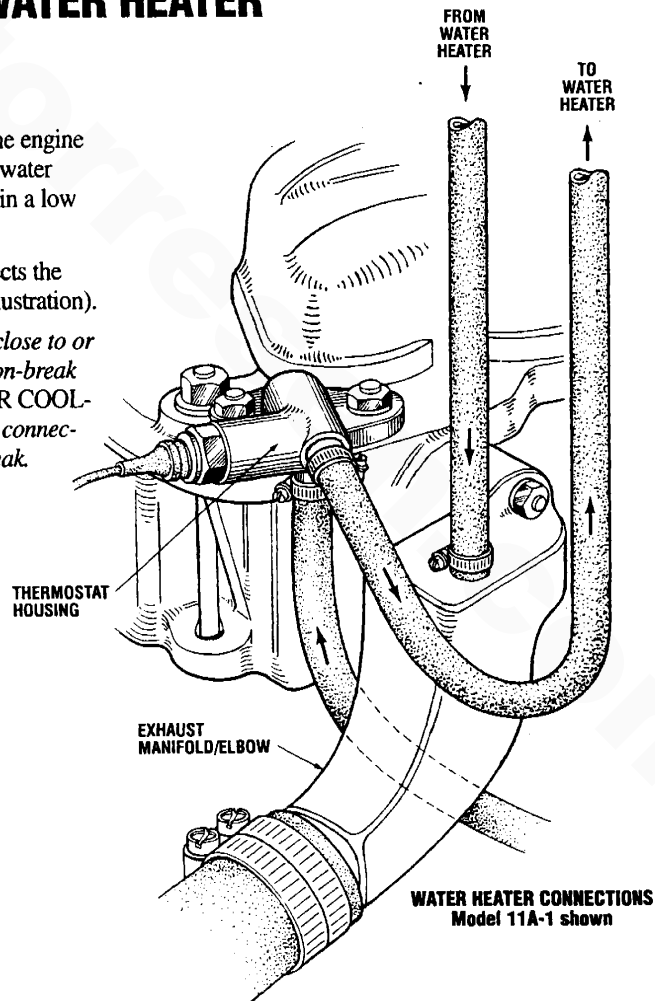

DIESEL FUEL

Use No. 2 diesel fuel with a cetane rating of 45 or higher. Do not use kerosene or home heating fuel.

FUEL ADDITIVES

If fungus or bacteria is causing fuel problems, you should have an authorized dealer correct these problems. Then use a diesel fuel biocide to sterilize the fuel (follow the manufacturer's instructions). Also use, on a regular basis, a fuel conditioner such as *STA-BIL*. Follow the manufacturer's instructions for the quantity to add.

CARE OF THE FUEL SUPPLY

Use only clean diesel fuel! Purchase a well-known brand of fuel. The clearance of the components in your fuel injection pump is very critical; invisible dirt particles which might pass through the filter can damage these finely finished parts. It is important to buy clean fuel and keep it clean. The best fuel can become unsatisfactory by careless handling or improper storage facilities. To assure that the fuel going to your engine is clean and pure, be sure to filter it properly. Install and regularly service a good Coast-Guard approved fuel filter/water separator having a filter element with a micron rating of #2 or #10. Install it between the fuel tank and the engine.

FUEL LIFT PUMP

To assure proper suction, the engine's fuel lift pump should not be more than 1 ft (300 mm) above the bottom of the fuel tank pickup tube.

Periodically check the fuel connections to and from the fuel lift pump and make sure that no leakage is present and that the fittings are tight and secure.

⚠ WARNING: Fuel leakage at the fuel lift pump or its connections is a fire hazard and should be corrected. Make sure proper ventilation exists whenever servicing fuel system components.

The fuel lift pump has two filter inserts in the pump's cap. To clean or replace them, unscrew the cap and retaining plate, and remove the two filter inserts. Note the disassembly sequence to ensure proper reassembly.

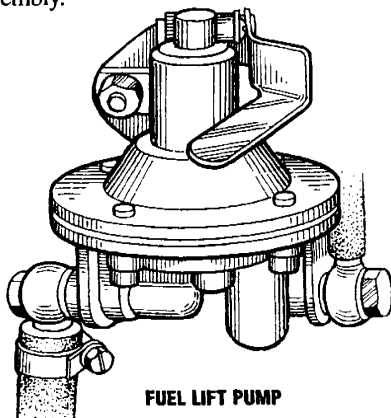

FUEL FILTER

The frequency of a fuel filter change depends on the degree of contamination of the fuel, however it should be performed at least after every 100 hours of engine operation.

Replacing the fuel filter

1. Clean the fuel line with a rag and clamp it off between the fuel lift pump and the fuel filter.
2. Pull off the inlet and outlet lines from the filter. Make sure dirt does not enter the fuel lines. Discard the used filter.
3. Install the new filter, making sure the flow arrow on the filter housing is pointed in the proper direction. Push the fuel lines as far as possible into the connection nipples of the new filter.

After installing the new filter, bleed the air from the fuel lines using the manual fuel primer (see *BLEEDING THE FUEL SYSTEM*).

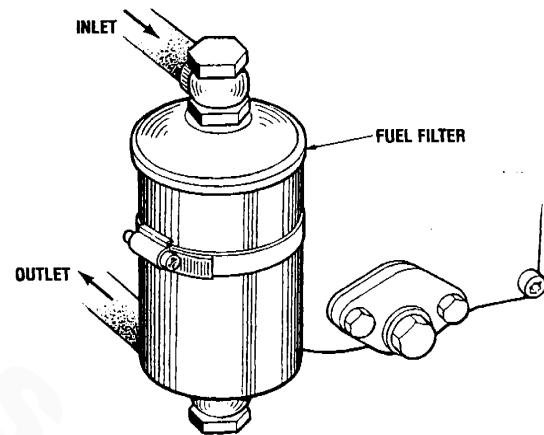

FUEL LINES

The fuel return line at the fuel tank should extend down to the bottom of the tank in the same manner as the fuel pickup tube. This *must* be done in an installation where the fuel tank is located below the engine's fuel system. This precaution insures against hard starting due to air displacing fuel siphoning out of the engine's fuel system through the return line when the engine is shut down.

WARNING: Shut off the fuel valve at the tank when servicing the fuel system. Take care in catching any fuel that may spill. DO NOT allow any smoking, open flames or other sources of fire near the fuel system when servicing. Ensure proper ventilation exists when servicing the fuel system.

FUEL FILTER/WATER SEPARATOR

Westerbeke recommends that you install and regularly service a good quality Coast Guard approved visual-type primary fuel filter of the water-separating type. This fuel filter/water separator must be installed between the fuel tank and the engine to prevent any contaminants or water that may be in the fuel from reaching the fuel lift pump and causing damage to the fuel system components. It may also prolong the life of the fuel filter that comes installed on the fuel line. It is the responsibility of the owner-operator to install this fuel filter/water separator. Select a filter that has a #2 or #10 micron rating.

Most installers include a fuel filter/water separator with the installation package as they are aware of the problems contaminants in the fuel can cause.

A typical fuel filter/water separator is illustrated below. This is the *Raycor Model 500 MA*. Keep in mind that if a water separator type filter is not installed between the fuel supply tank and the engine-mounted fuel system, any water in the fuel will affect the fuel pump, engine filter and injection equipment. The owner/operator is responsible for making certain the fuel reaching the engine's injection equipment is free of impurities. This process is accomplished by installing and maintaining a proper fuel filter/water separator.

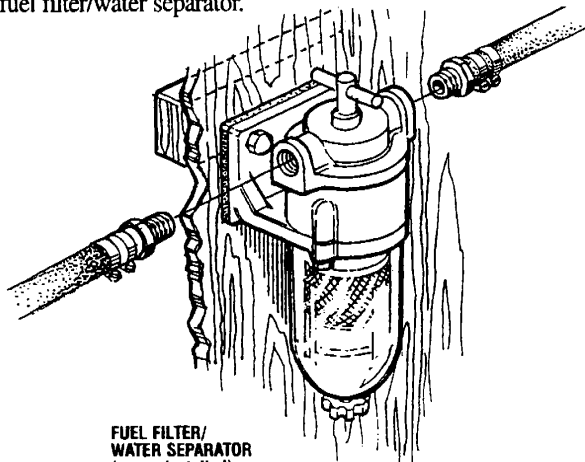

FUEL FILTER/
WATER SEPARATOR
(owner installed)

FUEL INJECTION PUMP

The fuel injection pump is a very important component of the diesel engine, requiring the utmost care in handling. The fuel injection pump has been thoroughly bench-tested and the owner-operator is cautioned not to attempt to service it. The only adjustment the servicing mechanic should make to the fuel injection pump is the adjustment for engine idle speed (see *IDLE SPEED ADJUSTMENT* under *ENGINE ADJUSTMENTS*). If it requires servicing, remove it and take it to an authorized fuel injection pump service facility. Do not attempt to disassemble and repair it.

FUEL INJECTOR

For information about removing and checking the fuel injector, see *TESTING THE FUEL INJECTOR* under *ENGINE ADJUSTMENTS*.

In case of severe vibrations and detonation noise, have the injectors checked and overhauled by an authorized fuel injection service center. Poor fuel quality, contaminants and loss of positive fuel pressure to the injection pump can result in injector faults. Since fuel injectors must be serviced in a clean room environment, it is best to carry at least one extra injector as a spare should a problem occur.

BLEEDING THE FUEL SYSTEM

The fuel injection pump is self-bleeding; any air in the fuel lines will bleed out through the fuel return line. Bleeding can also be done by using the manual fuel primer on the fuel lift pump (see illustration). In case the engine is shut down due to lack of fuel, use the manual fuel primer to bleed the system after refilling the fuel tank; it will not be necessary to disconnect the fuel lines to bleed the air. Also use the manual fuel primer to bleed the system after changing the fuel filters.

Bleeding the fuel system will also be necessary before the engine is layed-up during the off-season or for prolonged periods of inactivity. See *LAY-UP AND RECOMMISSIONING*.

To use the manual fuel primer, work the lever back and forth with slow complete strokes. If pressure isn't felt, rotate the engine 1/2 turn; this will reposition the fuel pump to improve the pumping action.

SPARE PARTS

While the likelihood of having to service the system at sea is slim, the possibility does exist. Therefore, we recommend that banjo washers, injector seat washers and a fuel filter be carried on board at all times. Purchase needed spare parts from your local WESTERBEKE dealer or distributor. If a leak should develop at a banjo washer that cannot be corrected by a simple tightening of the fitting, replace the sealing washer with a replacement found in the hardware kit for your model.

DC ELECTRICAL SYSTEM

12 VOLT DC CONTROL CIRCUIT

The engine has a 12 volt DC electrical control circuit that is shown on the wiring diagrams. Refer to these diagrams when troubleshooting or when servicing the DC electrical system.

CAUTION: To avoid damage to the battery charging circuit, never shut off the engine battery switch while the engine is running. Shut off the engine battery switch, however, to avoid electrical shorts when working on the engine's electrical circuit.

CONTROL PANEL

The engine is started by using the keyswitch on the control panel. The keyswitch has three positions: OFF, ON, and START (see STARTING/STOPPING PROCEDURE).

NOTE: Push the key in to preheat after turning the key to the ON position.

NOTE: Periodically lubricate the keyswitch with LOCKEZE to maintain proper operation.

The oil pressure/coolant temperature alarm beeps when either the oil pressure is too low or the engine is overheated.

The hourmeter registers the elapsed engine running time, and should be used as a guide for the maintenance schedule.

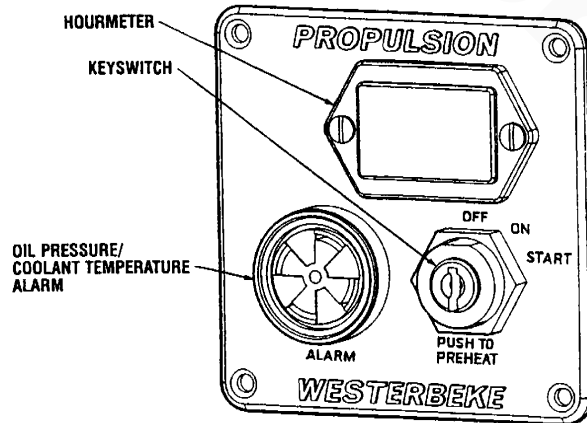

CONTROL PANEL

ENGINE CIRCUIT BREAKER

The DC wiring harness on the engine is protected by an engine-mounted manual reset circuit breaker (10 amps DC). Excessive current draw or electrical overload anywhere in the instrument panel wiring or engine wiring will cause the breaker to trip. In this event the engine will shut down because the opened breaker disconnects the fuel supply. If this should occur, check and repair the source of the problem. After repairing the fault, reset the breaker and restart the engine.

BATTERY

The minimum recommended capacity of the battery used in the engine's 12 volt DC control circuit is 200 Cold Cranking Amps (CCA).

Battery Care

Review the manufacturer's recommendations and then establish a systematic maintenance schedule for your engine's starting batteries and service batteries.

- Monitor your voltmeter for proper charging during engine operation.
- Check the electrolyte level and specific gravity with a hydrometer.
- Use only distilled water to bring electrolytes to a proper level.
- Make certain that battery cable connections are clean and tight to the battery posts and to your engine.
- Keep your batteries clean and free of corrosion.

WARNING: Sulfuric acid in lead batteries can cause severe burns on skin and damage clothing. Wear protective gear.

Checking the Service Battery

Check the voltage of the service battery. This battery should have a voltage between 13 and 14 volts when the engine is running. If not, there is a problem in the service battery charging circuit. Troubleshoot the service battery charging circuit by checking the wiring and connections, the solenoid, isolator, battery switch, and the battery itself.

ALTERNATOR TROUBLESHOOTING

⚠ WARNING: A failed alternator can become very hot. Do not touch until the alternator has cooled down.

Use this troubleshooting section to determine if a problem exists with the charging circuit or with the alternator. If it is determined that the alternator or voltage regulator is faulty, have a qualified technician check it.

The alternator charging circuit charges the starting battery and the service battery. An isolator with a diode, a solenoid or a battery selector switch is usually mounted in the circuit to isolate the batteries so the starting battery is not discharged along with the service battery. If the alternator is charging the starting battery but not the service battery, the problem is in the service battery's charging circuit and not with the alternator.

Testing the Alternator

⚠ CAUTION: Before starting the engine make certain that everyone is clear of moving parts! Keep away from sheaves and belts during test procedures.

⚠ WARNING: When testing with a multimeter: DC and AC circuits are often mixed together in marine applications. Always disconnect a shore power cord, isolate DC and AC converters, and shut down the engine before performing DC testing. No AC tests should be made without a proper knowledge of AC circuits.

1. Start the engine.
2. After the engine has run for a few minutes, measure the starting battery voltage at the battery terminals using a multimeter set on DC volts.
 - a. If the voltage is increasing toward 14 volts, the alternator is working; omit Steps 3 through 8 and go directly to "Checking the Service Battery" on the next page.
 - b. If the voltage remains around 12 volts, a problem exists with either the alternator or the charging circuit; continue with Steps 3 through 8.

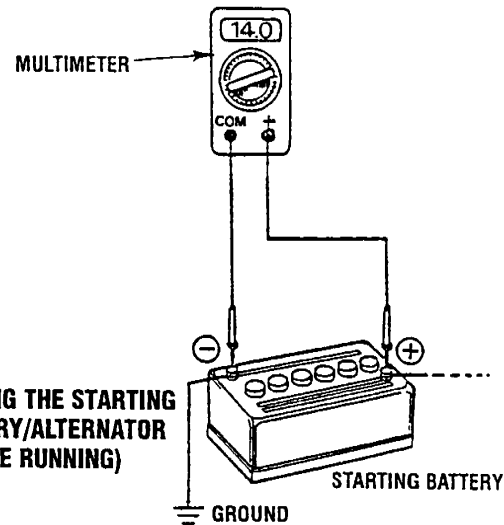

TESTING THE STARTING BATTERY/ALTERNATOR (ENGINE RUNNING)

3. Turn off the engine. Inspect all wiring and connections. Ensure that the battery terminals and the engine ground connections are tight and clean.

⚠ CAUTION: To avoid damage to the battery charging circuit, never shut off the engine battery switch when the engine is running!

4. If a battery selector switch is in the charging circuit, ensure that it is on the correct setting.
5. Turn on the ignition switch, but do not start the engine.
6. Check the battery voltage. If the battery is in good condition, the reading should be 12 to 13 volts.

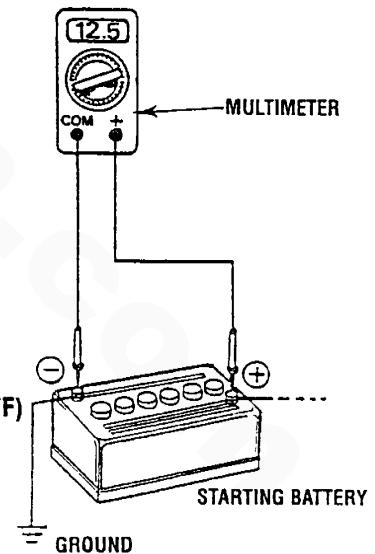

TESTING THE ALTERNATOR VOLTAGE (IGNITION ON - ENGINE OFF)

7. Now check the voltage between the alternator output terminal (B+) and ground. If the circuit is good, the voltage at the alternator will be the same as the battery, or if an isolator is in the circuit the alternator voltage will be zero. If neither of the above is true, a problem exists in the circuit between the alternator and the battery. Check all the connections — look for an opening in the charging circuit.

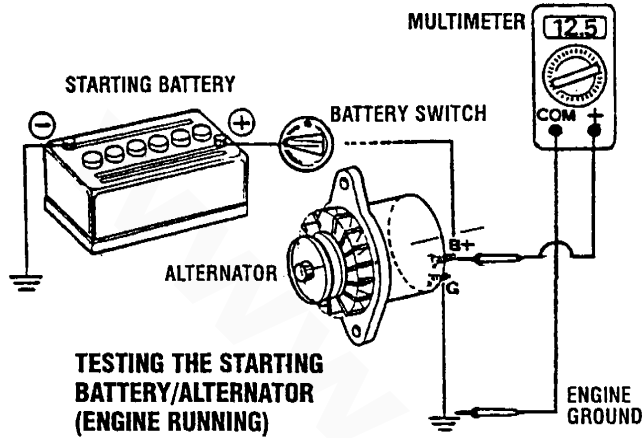

8. Start the engine again. Check the voltage between the alternator output and ground. The voltage reading for a properly operating alternator should be between 13.5 and 14.5 volts. If your alternator is over- or under-charging, have it repaired at a reliable service facility.

NOTE: Before removing the alternator for repair, use a voltmeter to ensure that 12 volts DC excitation is present at the EXC terminal if the previous test showed only battery voltage at the B output terminal.

If 12 volts is not present at the EXC terminal, trace the wiring and look for breaks and poor connections.

Checking the Service Battery

Check the voltage of the service battery. This battery should have a voltage between 13 and 14 volts when the engine is running. If not, there is a problem in the service battery charging circuit. Troubleshoot the service battery charging circuit by checking the wiring and connections, the solenoid, isolator, battery switch, and the battery itself.

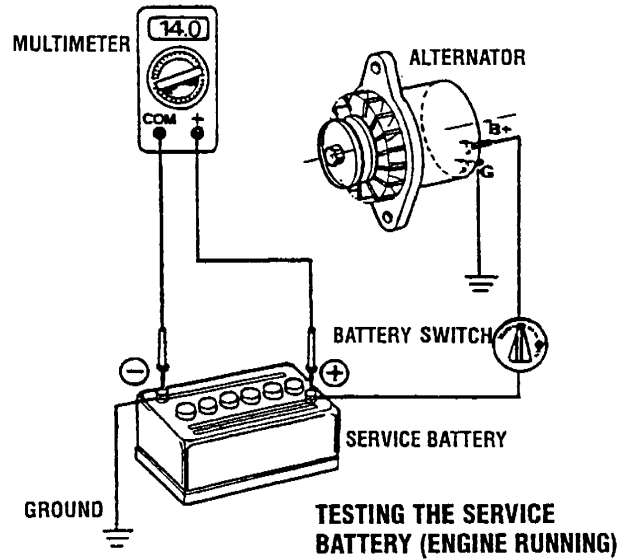

CAUTION: To avoid damaging the alternator diodes, do not use a high voltage tester (i.e. a megger) when performing tests on the alternator charging circuit.

DC ELECTRICAL SYSTEM

7A-1 MARINE DIESEL ENGINE WIRING DIAGRAM #45593

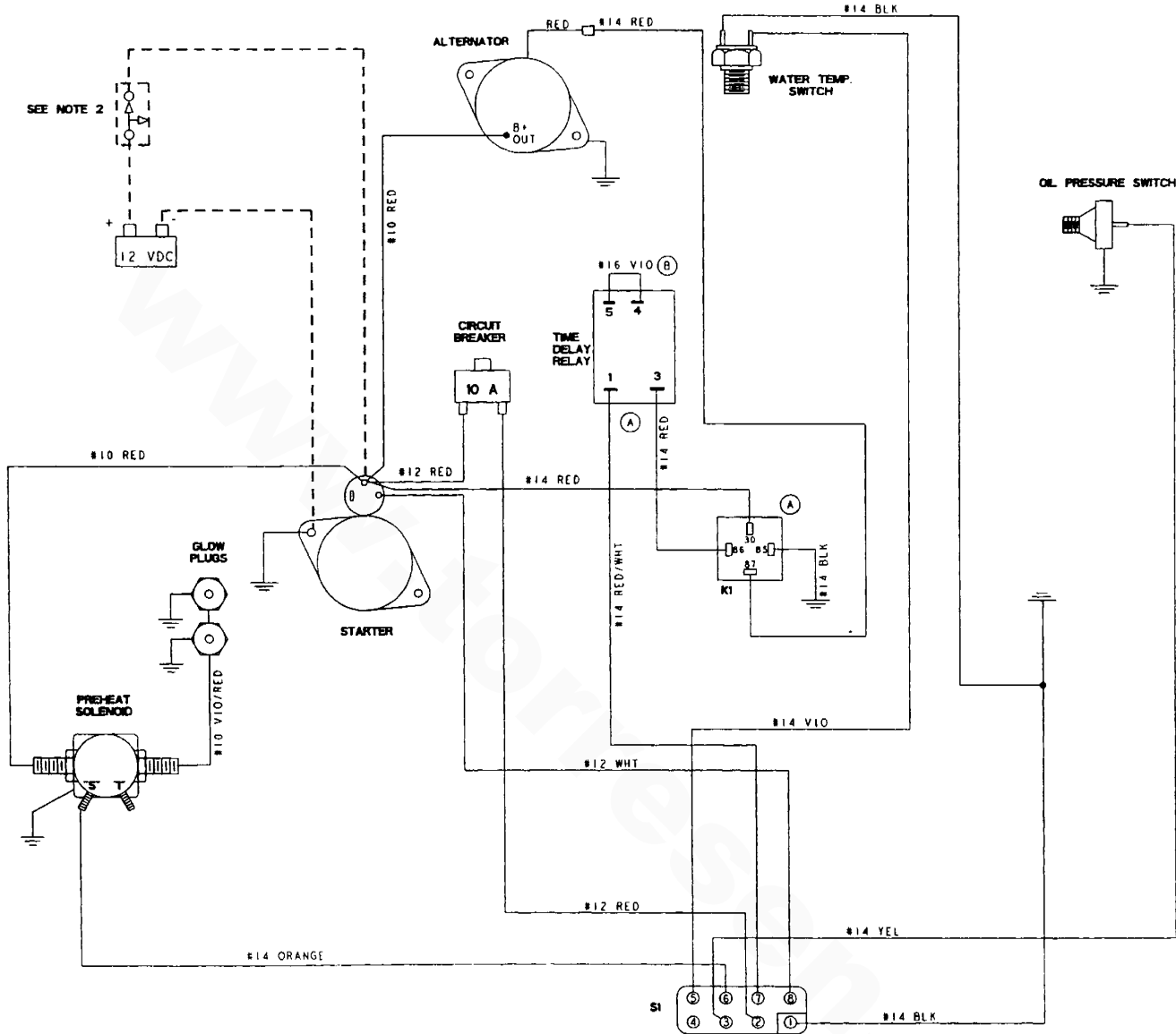

(B) NOTES:
 1. THE 7A-1 MODEL IS EQUIPPED WITH A TIME DELAY RELAY THAT PREVENTS THE EXCITATION OF THE ALTERNATOR DURING PREHEAT AND CRANKING. THE ALTERNATOR EXCITATION WILL OCCUR APPROX. 3MINS AFTER THE IGNITION KEY HAS BEEN TURNED ON

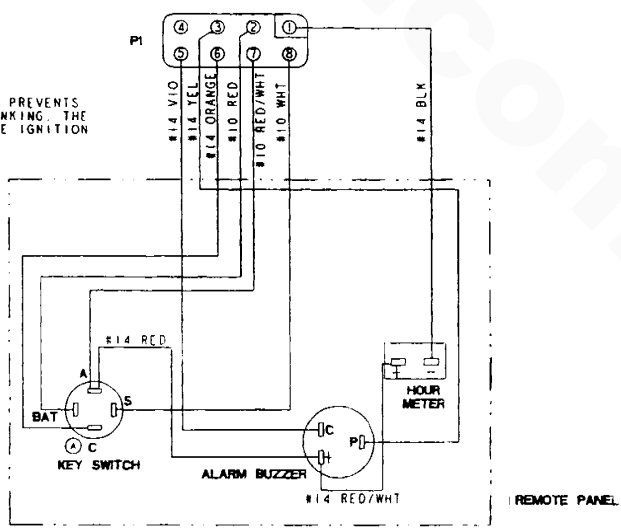

DC ELECTRICAL SYSTEM

7A-1 MARINE DIESEL ENGINE WIRING SCHEMATIC #45593

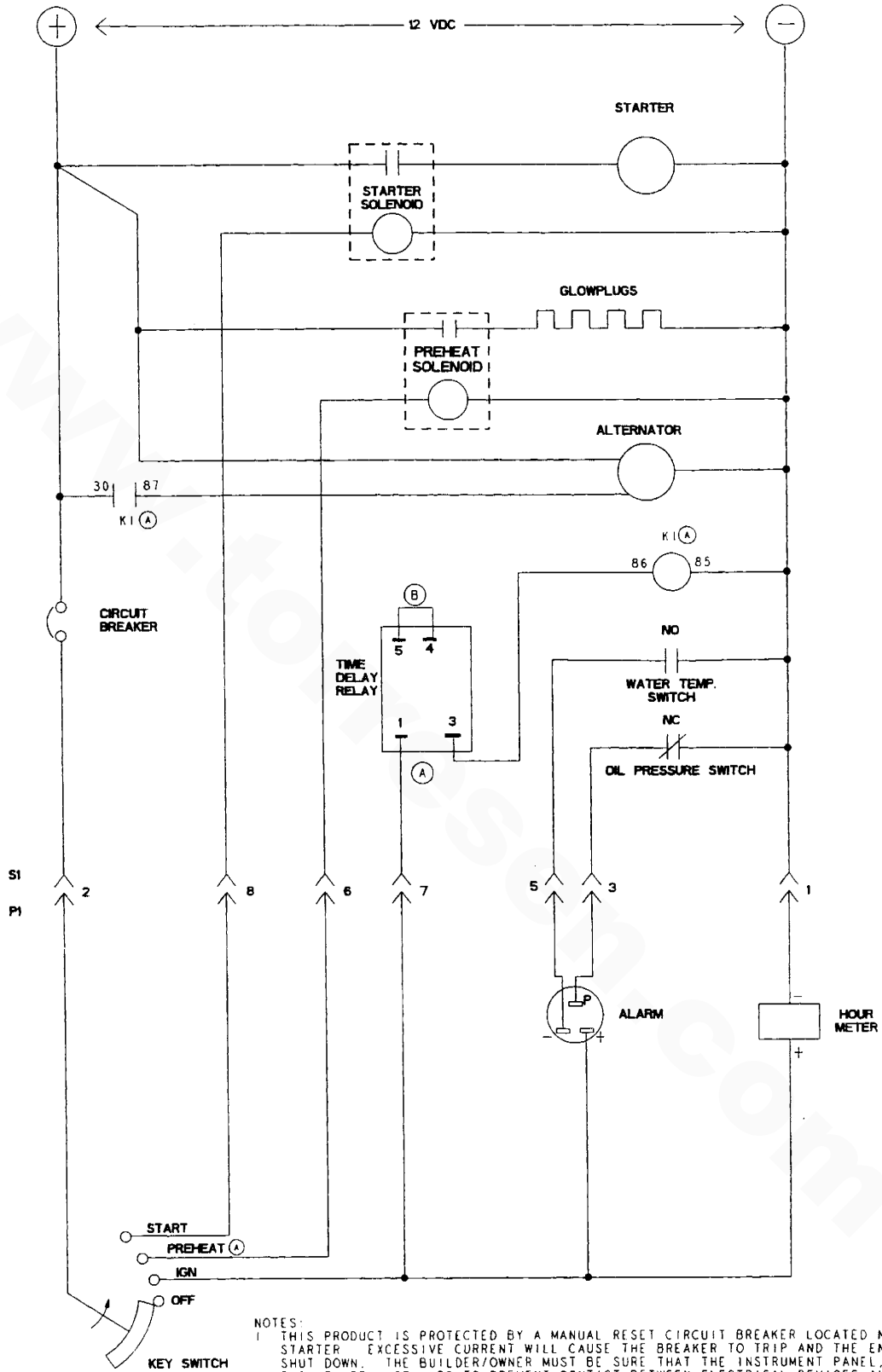

NOTES:

- 1 THIS PRODUCT IS PROTECTED BY A MANUAL RESET CIRCUIT BREAKER LOCATED NEAR THE STARTER. EXCESSIVE CURRENT WILL CAUSE THE BREAKER TO TRIP AND THE ENGINE WILL SHUT DOWN. THE BUILDER/OWNER MUST BE SURE THAT THE INSTRUMENT PANEL, WIRING, AND ENGINE ARE INSTALLED TO PREVENT CONTACT BETWEEN ELECTRICAL DEVICES AND SEAWATER.
- 2 AN ON-OFF SWITCH SHOULD BE INSTALLED BETWEEN THE BATTERY AND STARTER TO DISCONNECT THE BATTERY IN AN EMERGENCY AND WHEN LEAVING THE BOAT. A SWITCH WITH A CONTINUOUS RATING OF 175 AMPS. AT 12 VDC WILL SERVE THIS FUNCTION. THIS SWITCH SHOULD NOT BE USED TO MAKE OR BREAK THE CIRCUIT.



DC ELECTRICAL SYSTEM

11A-1 MARINE DIESEL ENGINE WIRING DIAGRAM # 44542

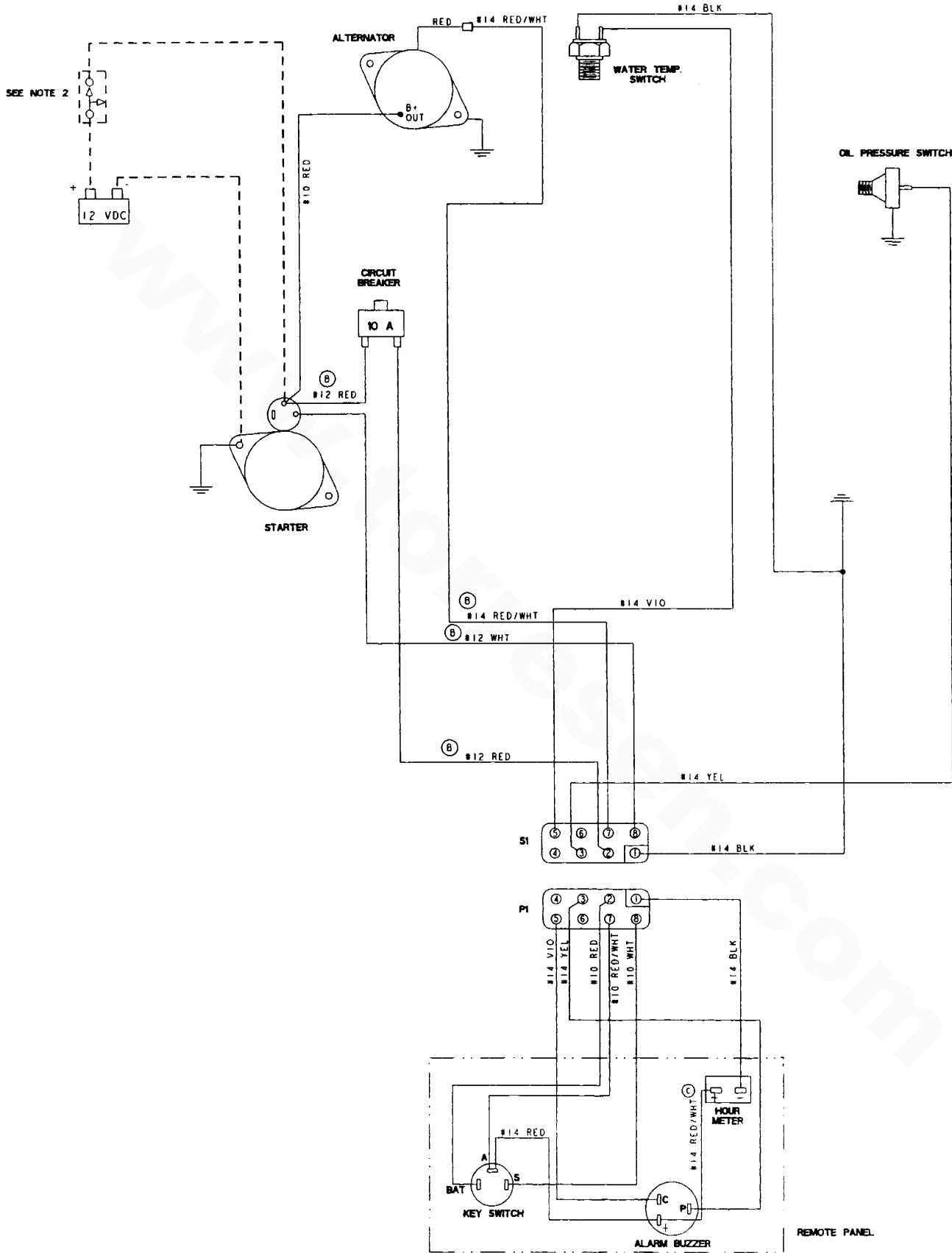

DC ELECTRICAL SYSTEM

11A-1 MARINE DIESEL ENGINE WIRING SCHEMATIC # 44542

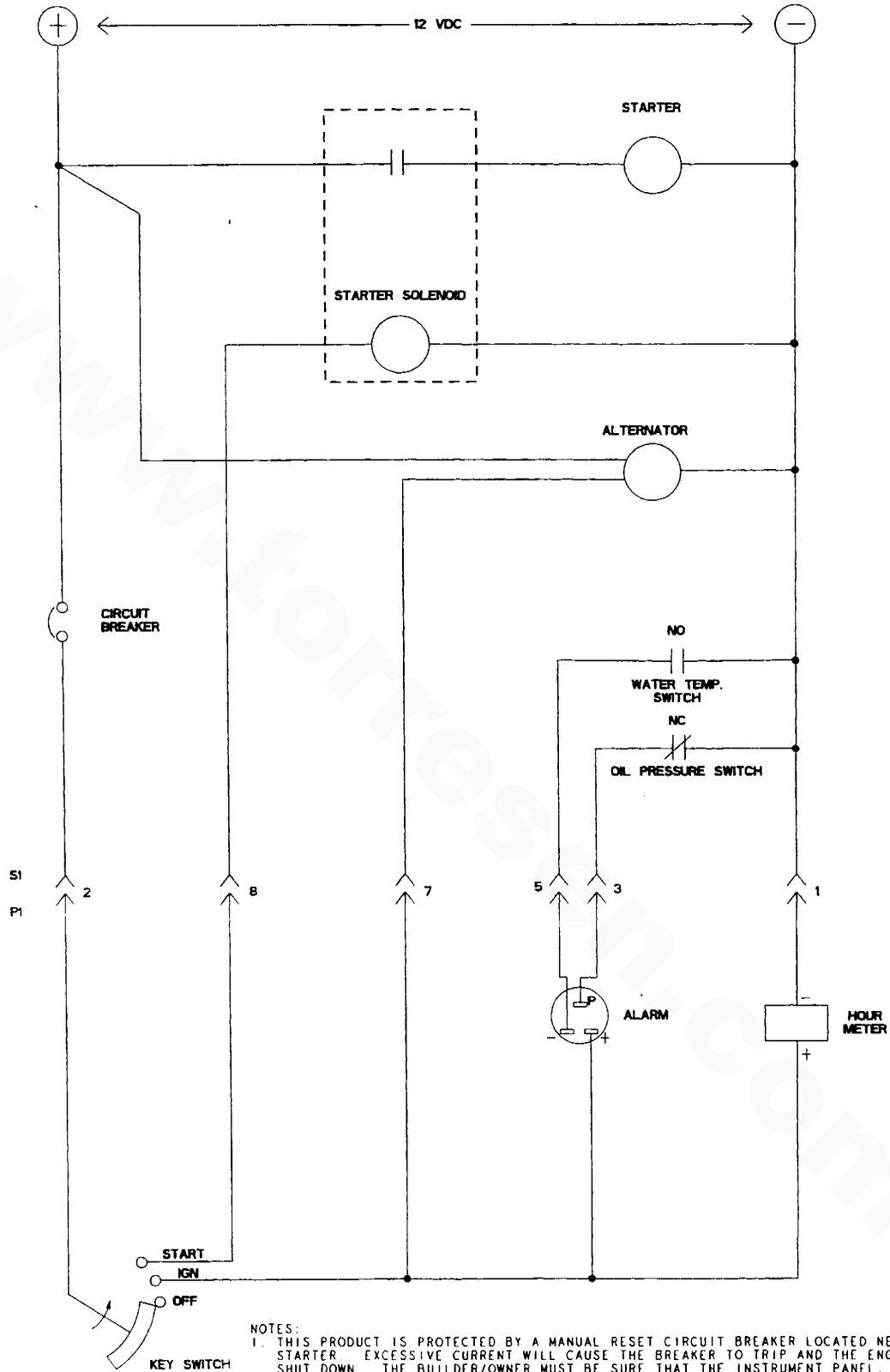

NOTES:

1. THIS PRODUCT IS PROTECTED BY A MANUAL RESET CIRCUIT BREAKER LOCATED NEAR THE STARTER. EXCESSIVE CURRENT WILL CAUSE THE BREAKER TO TRIP AND THE ENGINE WILL SHUT DOWN. THE BUILDER/OWNER MUST BE SURE THAT THE INSTRUMENT PANEL, WIRING, AND ENGINE ARE INSTALLED TO PREVENT CONTACT BETWEEN ELECTRICAL DEVICES AND SEAWATER.
2. AN ON-OFF SWITCH SHOULD BE INSTALLED BETWEEN THE BATTERY AND STARTER TO DISCONNECT THE BATTERY IN AN EMERGENCY AND WHEN LEAVING THE BOAT. A SWITCH WITH A CONTINUOUS RATING OF 175 AMPS. AT 12 VDC WILL SERVE THIS FUNCTION. THIS SWITCH SHOULD NOT BE USED TO MAKE OR BREAK THE CIRCUIT.



GLOW PLUGS

MODEL 7A-1 ONLY

DESCRIPTION

The glow plugs (2) are wired through the preheat solenoid. When PREHEAT is pressed at the control panel this solenoid should "click" on and the glow plug should begin to get hot.

INSPECTION

To inspect the plug, remove the electrical terminal connections, then unscrew each plug from the air intake adapter. Thoroughly clean each plug's tip and threads with a soft brush and cleaning solution to remove all the carbon and oil deposits. While cleaning, examine the tip for wear and burn erosion; if it has eroded too much, replace the plug.

TESTING

An accurate way to test glow plugs is with an ohmmeter. Touch one prod to the glow plug's wire connection, and the other to the body of the glow plug, as shown. A good glow plug will have a 0.55 ohm resistance. This method can be used with the plug in or out of the engine. You can also use an ammeter to test the power drain (5 - 6 amps per plug).

WARNING: *These glow plugs will become very hot to the touch. Be careful not to burn your fingers when testing the plugs.*

Re-install the plugs in the air intake adapter and test them again. The plugs should get very hot (at the terminal end) within 7 to 15 seconds. If the plugs don't heat up quickly, check for a short circuit. When reinstalling the glow plugs, use anti-seize compound on the threads.

WARNING: *Do not keep a glow plug on for more than 30 seconds.*

Glow plug tightening torque: 7 - 11 ft-lb (1.0 - 1.5 m-kg)

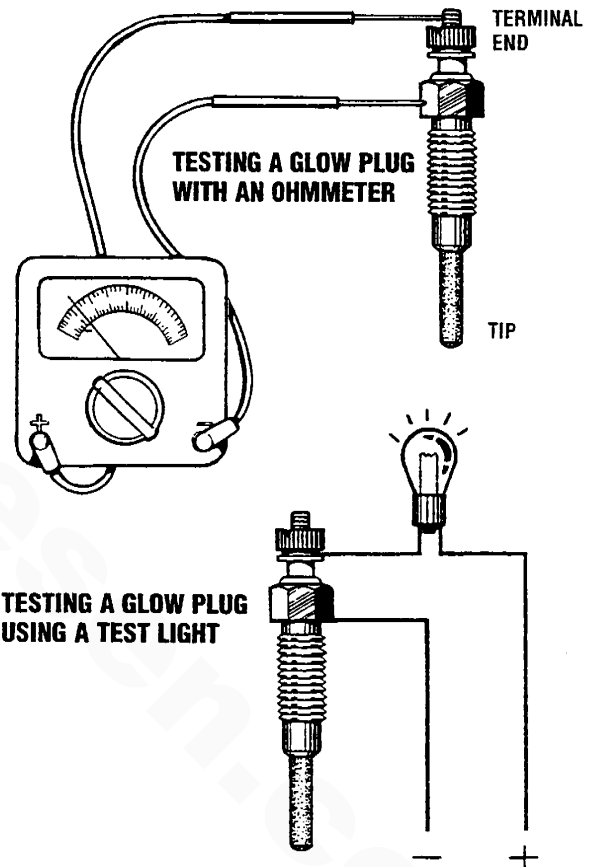

NOTE: WESTERBEKE recommends that the following engine adjustments be performed by a competent engine mechanic. The information below is provided to assist the mechanic.

TIGHTENING THE CYLINDER HEAD

After the initial break-in period (approximately 50 hours), retorque the cylinder head nuts. Do this when the engine is cold.

1. Remove the cylinder head cover and gasket.
2. Retighten the four cylinder head nuts in an X-pattern sequence as shown in the illustration. Start with any nut. Before applying the torque to a nut, loosen it 1/4 to 1/2 a turn, then apply the torque. See **TORQUE SPECIFICATIONS** for the proper torque.
3. Reinstall the cylinder head cover and gasket. Insert new plastic washers under the two nuts and tighten to the specified torque.

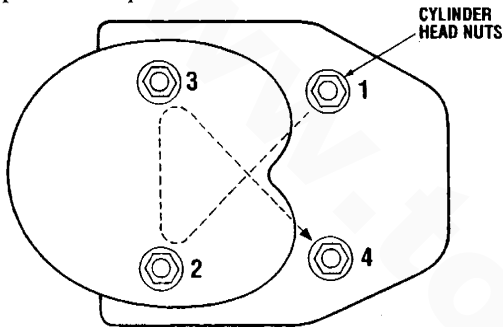

VALVE CLEARANCE ADJUSTMENT

Check the valve clearances after the first 50 hours of operation and every 600 hours thereafter.

NOTE: Tighten the cylinder head bolts to their specified torque before adjusting the valve clearances (see **TIGHTENING THE CYLINDER HEAD**).

Adjust the valve clearances when the engine is cold. The clearance is 0.2 mm (0.008 in.) for both intake and exhaust valves.

1. Remove the cylinder head.
2. Check to make sure the automatic decompression device is in its normal operating position, i.e. not activated (see illustration).

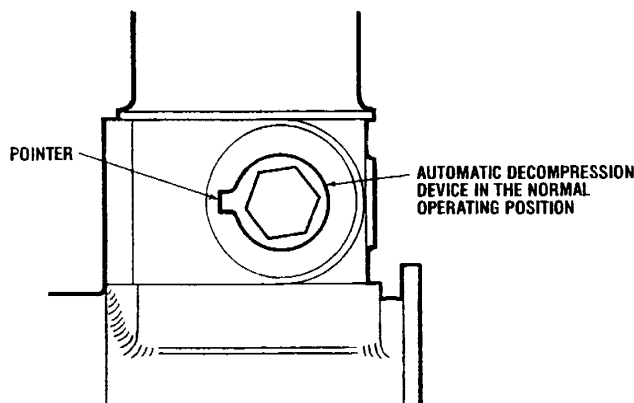

3. Set the piston at the TDC of the compression stroke.
4. Loosen the locknuts on the valve setting screws (see illustration).

5. For each valve, insert a 0.2 mm (0.008 in.) feeler gauge between the valve stem and the rocker arm, and adjust the clearance until a slight drag is felt on the gauge when it is pulled out.
6. Tighten the locknut while holding the setting screw with a screwdriver.
7. Recheck the clearance.

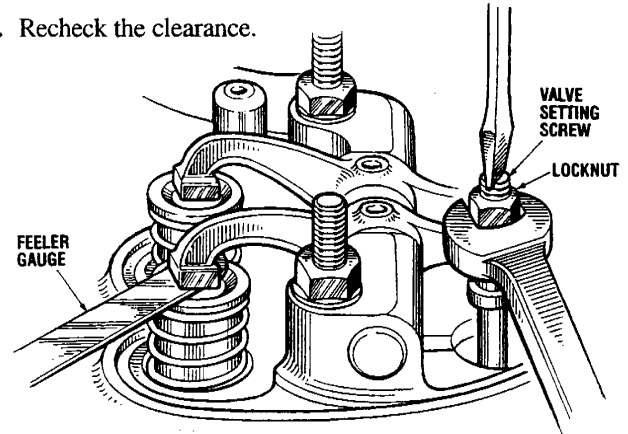

ENGINE COMPRESSION TEST

To check the engine's compression pressure, warm up the engine, shut off the raw water through-hull, remove the fuel injector, and install a compression adapter in the injector hole. Connect a compression tester on the adapter and crank the engine with the starter motor until the pressure reaches a maximum value.

Compression pressure at 350 rpm:

Minimum: 435.0 psi (30.6 kg/cm²)

Standard: 478.5 psi (33.6 kg/cm²)

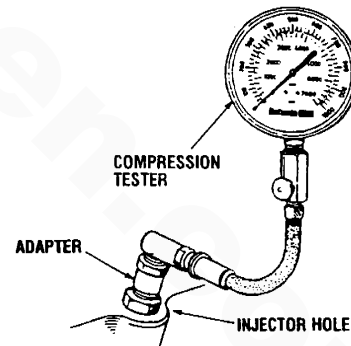

If the pressure is weak, the problem is either valve- or piston-related. Check the valve clearance, adjust as needed, and test again. If the compression is still low, apply a small amount of oil into the cylinder to seal the rings, and repeat the test. If the compression comes up, the rings are faulty.

An abnormally high reading indicates heavy carbon accumulation, a condition that might be accompanied by high pressure and noise.

NOTE: In case of severe vibrations and detonation noise, have the injector checked and overhauled by an authorized fuel injection service center. Poor fuel quality, contaminants and loss of positive fuel pressure to the injection pump will result in injector faults.

ENGINE ADJUSTMENTS

NOTE: WESTERBEKE recommends that the following engine adjustments be performed by a competent engine mechanic. The information below is provided to assist the mechanic.

TESTING THE FUEL INJECTOR

NOTE: The fuel injector must be serviced in a clean room environment.

Removing the Fuel Injector

1. Disconnect the high pressure fuel line from the injector, then loosen the line at its attachment to the injection pump and move it out of the way of the injector. Avoid bending the line.
2. Remove the fuel return line in its entirety from the top of the injector. Take care not to lose the two sealing washers and banjo bolt that attaches the fuel return line to the injector.
3. Remove the fuel injector holder bracket mounting nuts, then remove the holder bracket.
4. Remove the fuel injector.

NOTE: Clean the area around the base of the injector prior to lifting it out of the cylinder head to help prevent any rust or debris from falling down into the injector hole. If the injector will not lift out easily and is held in by carbon build-up or the like, work the injector side-to-side with the aid of a socket wrench to free it, and then lift it out.

The injector seats in the cylinder head on a copper sealing washer. This washer should be removed with the injector and replaced with a new washer when the injector is reinstalled.

5. Remove the gaskets.
6. Remove the O-rings.

Fuel Injector Components

The fuel injector consists of the following parts:

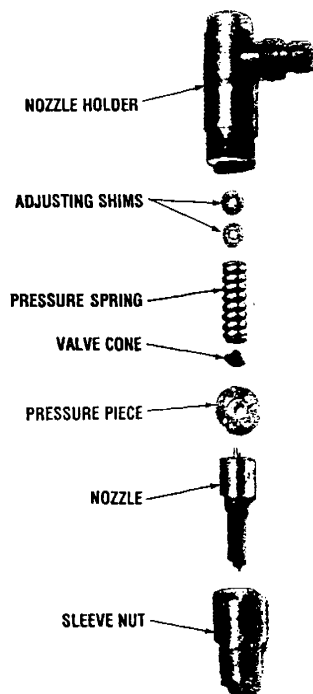

FUEL INJECTOR COMPONENTS

Checking The Injection Starting Pressure

1. Set the nozzle tester in a clean place where there is no dust or dirt.
2. Mount the nozzle and the nozzle holder on the nozzle tester.
3. Use new fuel that has an approximate temperature of 68°F (20°C).
4. Bleed the air in the nozzle line by pumping the nozzle tester handle several times.
5. Slowly lower the nozzle tester handle and check the reading on the pressure gauge when the injection starts.

Injection starting pressure:
2850 – 2900 lb/in² (200 – 203 kg/cm²)

CAUTION: Keep hands away from the nozzle spray. The spray nozzle velocity is such that it may penetrate deeply into the fingers and hands, destroying tissue. If it enters the bloodstream, it may cause blood poisoning.

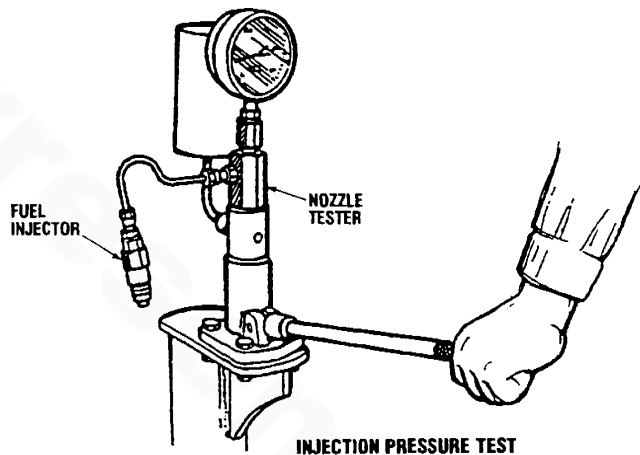

6. If the injection starting pressure is not within the specified range, adjust it by replacing the shim with one of a more appropriate thickness.

If the thickness of a shim is increased 0.004 in (0.1 mm), the injection pressure increases approximately 145 lb/in² (10.1 kg/cm²).

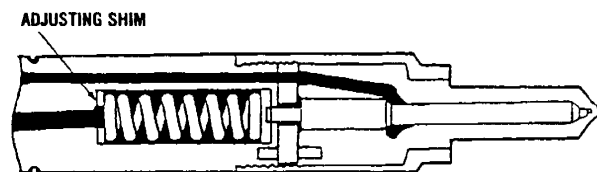

FUEL INJECTOR ADJUSTING SHIM

NOTE: WESTERBEKE recommends that the following engine adjustments be performed by a competent engine mechanic. The information below is provided to assist the mechanic.

Tightness of the Valve Seat

Apply a pressure of 2600 lb/in² (182 kg/cm²) and check if fuel leaks from the injection nozzle holes. If fuel leaks, disassemble, wash and recheck the injector nozzle or replace it.

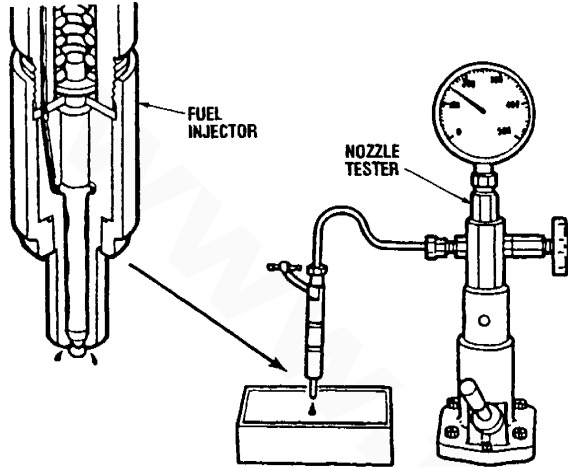

CHECKING THE TIGHTNESS OF THE VALVE SEAT

Inspecting the Spray Pattern.

1. Mount the nozzle and nozzle holder on the nozzle tester.
2. Bleed the air in the nozzle line by pumping the nozzle tester handle several times.
3. Keep the reading on the pressure gauge of the nozzle tester just below the injection starting pressure while pumping the handle of the nozzle tester as quickly as possible so that a pulsating whistling sound is heard. Check the atomization of the fuel injected from the nozzle (see illustration).

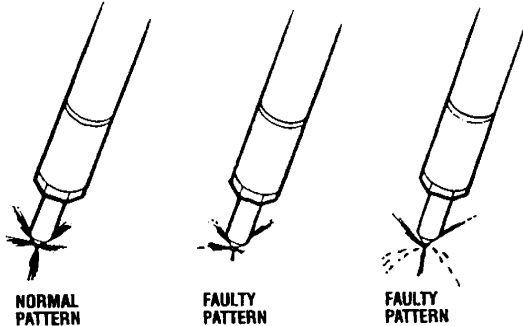

FUEL INJECTOR SPRAY PATTERNS

Normal Pattern: The fuel is sprayed uniformly and finely from all five injection nozzle holes.

Faulty Pattern: The number of fuel sprays and fineness of the injected fuel is substandard. If the condition of the injected fuel is substandard, disassemble, wash and recheck the injection nozzle or replace it.

Checking the Nozzle Body and Needle Valve

1. Check for damage to the valve seat of the needle valve and check for damage to other parts.
2. Check for damage to the nozzle body. Hold the nozzle body upright and insert four-fifths of the needle valve. Then release the needle valve and check that it drops into the valve seat under its own weight.

Reassembly

Be sure to do the following when reassembling the fuel injector:

1. Tighten the nozzle body onto the nozzle holder to the specified torque.

Nozzle torque:

29 – 36 ft-lb (4.0 – 5.0 kg-m)

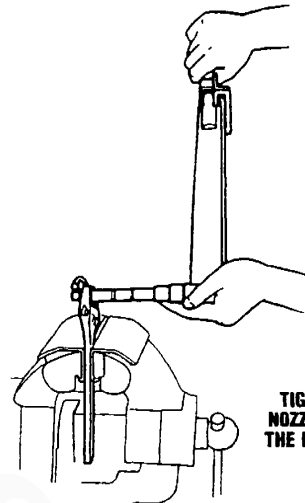

TIGHTENING THE NOZZLE BODY ONTO THE NOZZLE HOLDER

2. After assembling the fuel injector, check the injection starting pressure and the spray pattern.

Injector Installation

The fuel injector installation sequence is the reverse of the removal sequence. Make sure to include the following:

1. Use new gaskets – do not reuse the old gaskets.
2. Replace the copper sealing washer for each injector.
3. Tighten the fuel injector holder bracket mounting nuts to the specified torque.

Bracket mounting nuts torque:

6 – 9 ft-lb (0.8 – 1.2 kg-m)

ENGINE ADJUSTMENTS

NOTE: WESTERBEKE recommends that the following engine adjustments be performed by a competent engine mechanic. The information below is provided to assist the mechanic.

DRIVE BELT ADJUSTMENT

The drive belt must be properly tensioned. A loose drive belt will not provide proper alternator charging and will eventually damage the alternator. A drive belt that is too tight will pull the alternator out of alignment and/or cause the alternator to wear out prematurely. Excessive drive belt tension can also cause rapid wear of the belt. A slack belt or the presence of oil on the belt can cause belt slipping, resulting in high operating temperatures and rpm variations.

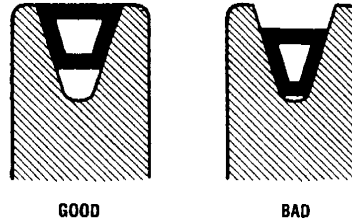

WARNING: Never attempt to check or adjust the drive belt's tension while the engine is in operation.

Checking Belt Tension

1. To check the belt tension, press the belt at the approximate midpoint (just above the bellhousing) between the alternator pulley and the flywheel pulley with a force of 22 lbs (10 kgf) (98 N). The belt deflection should be 3/8" - 1/2" (10 - 12 mm) deep.

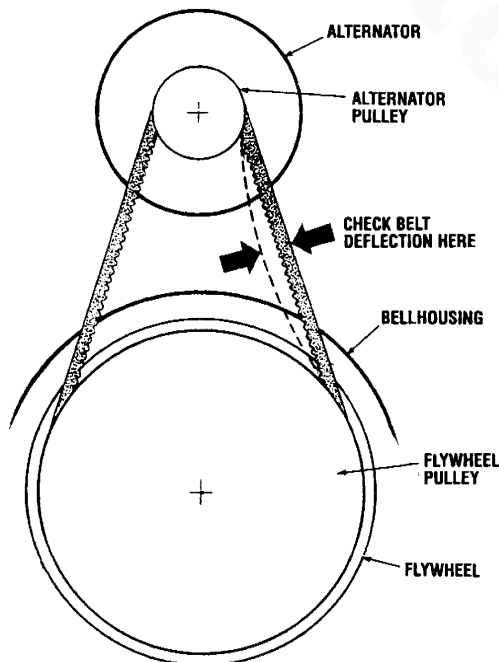

Adjusting Belt Tension

1. To adjust the belt tension, loosen the alternator adjusting strap bolt and the base mounting bolt.
2. With the belt loose, inspect the belt for damage, wear, cracks and frayed edges. If the belt is damaged, replace it. If it is nearly worn out and deeply sunk in the pulley groove, replace it.

3. Pivot the alternator on the base mounting bolt to the left or right as required, to loosen or tighten.
4. Tighten the base mounting bolt and the adjusting strap bolt securely.
5. Run the engine for about 5 minutes, then shut down and recheck the belt tension.

The following troubleshooting chart provides information based upon certain problem indicators, the probable causes of these problems, and the recommendations to overcome them.

1. Engine will not start

Problem	Probable Cause	Remedy
Fuel supply failure (check by cranking engine and listening for the characteristic squirting in the fuel injector).	<p>If squirting cannot be heard:</p> <ol style="list-style-type: none"> 1. No fuel in tank. 2. Vent hole in tank cap plugged. 3. Fuel filter clogged. 4. Faulty injector nozzle. 5. Faulty injection pump. 6. Fuel line blocked. 7. Broken fuel line or leaking connection. <p>If squirting can be heard:</p> <ol style="list-style-type: none"> 1. Starting fuel button not pulled. 2. Gasoline instead of diesel in tank. 3. Air intake blocked. 	<ol style="list-style-type: none"> 1. Fill tank. 2. Replace cap. 3. Replace filter. 4. Check/replace nozzle. 5. Check/repair/replace pump. 6. Check fuel lines and remove blockage. 7. Replace fuel line/tighten connections. <ol style="list-style-type: none"> 1. Pull button. 2. Drain gasoline, flush system, fill with diesel. 3. Check system for blockage.
Poor compression	<ol style="list-style-type: none"> 1. Automatic decompression device malfunction. 2. Incorrect valve clearance. 3. Valves not seating properly. 4. Cylinder head loose. 5. Piston rings stuck in grooves. 6. Worn cylinder and piston. 7. Rusty exhaust valve. <ol style="list-style-type: none"> 8. Valves sticking. 	<ol style="list-style-type: none"> 1. Check/replace automatic decompression device. 2. Adjust valve clearance. 3. Check/repair/replace valves. 4. Tighten cylinder head nuts. 5. Check rings and clean the piston. 6. Overhaul the engine. 7. Spray lubricating oil into the cylinder, activate the automatic decompression device, then start. 8. Free valves.
Difficult to crank the engine	<ol style="list-style-type: none"> 1. Lube oil too thick. 2. Bearings seized. 3. Piston seized. 	<ol style="list-style-type: none"> 1. Change to correct viscosity. 2. Overhaul the engine. 3. Overhaul the engine.

2. Engine starts but fires intermittently or soon stops

Faulty fuel supply	<ol style="list-style-type: none"> 1. Fuel filter clogged. 2. Water in fuel. 3. Faulty injector nozzle. 4. Faulty injection pump. 5. Fuel line clogged. 6. Fuel lines or connections leak. 	<ol style="list-style-type: none"> 1. Replace filter. 2. Drain fuel; fill with clean fuel. 3. Check/replace nozzle. 4. Check/repair/replace pump. 5. Check the fuel lines and remove the blockage. 6. Replace fuel line/tighten connections.
Faulty air intake and/or exhaust system.	<ol style="list-style-type: none"> 1. Restricted/blocked exhaust system. 2. Restricted/blocked air intake. 	<ol style="list-style-type: none"> 1. Check/clean exhaust system. 2. Check/clean air intake system.
Poor Compression	See <i>Poor Compression</i> under <i>Engine will not Start</i> .	

(continued)



ENGINE TROUBLESHOOTING

3. Engine lacks power and/or makes black smoke

Problem	Probable Cause	Remedy
Operating conditions	<ol style="list-style-type: none"> 1. Engine overloaded. 2. Power reduction due to altitude and/or ambient temperature has not been considered. 3. Clogged air filter. 	<ol style="list-style-type: none"> 1. Reduce the load. 3. Clean/replace.
Faulty fuel supply	<ol style="list-style-type: none"> 1. Gasket under injector missing or too many gaskets are installed. 2. Fuel filter clogged. 3. Faulty injection nozzle. 4. Faulty injection pump. 	<ol style="list-style-type: none"> 1. Correct the number of gaskets. 2. Replace filter. 3. Check/replace nozzle. 4. Check/repair/replace pump
Engine condition	<ol style="list-style-type: none"> 1. Excessive carbon on piston and cylinder head. 2. Faulty piston rings. 3. Worn piston and cylinder. 4. Worn bearings. 	<ol style="list-style-type: none"> 1. Decarbonize. 2. Check/replace piston ring set. 3. Overhaul engine. 4. Overhaul engine.

4. Faulty running

Engine overheats	<ol style="list-style-type: none"> 1. Engine overloaded. 2. Faulty raw water pump impeller. 3. Faulty thermostat. 4. Clogged raw water intake strainer. 5. Lube oil level too high. 6. Faulty injector nozzle. 	<ol style="list-style-type: none"> 1. Reduce load. 2. Replace impeller. 3. Check/replace thermostat. 4. Clean the strainer. 5. Drain to proper level. 6. Check/replace nozzle.
Knocking	<ol style="list-style-type: none"> 1. Injector needle sticking. 2. Fuel timing too far advanced. 3. Broken piston ring. 4. Worn piston. 5. Worn bearings. 6. Loose flywheel. 	<ol style="list-style-type: none"> 1. Replace nozzle. 2. Adjust timing. 3. Replace piston ring set. 4. Replace piston and liner. 4. Replace bearings. 6. Tighten flywheel nut.
Engine is hunting	<ol style="list-style-type: none"> 1. Engine is overheating. 2. Air in fuel lines. 3. Governor sticking or defective. 4. Fuel filter clogged. 	<ol style="list-style-type: none"> 1. See <i>Engine Overheats</i>, above. 2. Check fuel system for leaking connections. 3. Free the governor or replace. 4. Replace filter.
Engine stops suddenly	<ol style="list-style-type: none"> 1. Fuel tank is empty. 2. Vent hole in fuel tank cap is plugged. 3. Vapor lock (fuel is too hot). 4. Clogged injector. 5. Fuel line is broken. 6. Seized piston. 7. Seized crankshaft. 	<ol style="list-style-type: none"> 1. Fill tank. 2. Replace tank cap. 3. Cool the fuel. 4. Replace nozzle. 5. Replace. 6. Replace piston and liner. 7. Repair/replace crankshaft and bearings.

(continued)



ENGINE TROUBLESHOOTING

Problem	Probable Cause	Remedy
Blue smoke	<ol style="list-style-type: none"> 1. Breather valve is clogged. 2. Oil seal at intake valve is defective. 3. Worn valves/valve guides. 4. Worn piston/cylinder. 	<ol style="list-style-type: none"> 1. Replace breather. 2. Replace oil seal. 3. Replace valves and guides. 4. Replace piston and cylinder.
White smoke	<ol style="list-style-type: none"> 1. Fuel timing is too late. 2. Injector nozzle is worn out. 3. Low engine operating temperature. 	<ol style="list-style-type: none"> 1. Adjust timing. 2. Replace nozzle. 3. Clean thermostat.
Oil in exhaust discharge	<ol style="list-style-type: none"> 1. Rings not seated. 2. Low compression – bad valve. 	<ol style="list-style-type: none"> 1. Initial 50 hours of operation required to seat rings. 2. Check/repair/replace valves.

5. Low Oil Pressure

Low oil pressure	<ol style="list-style-type: none"> 1. Incorrect oil viscosity. 2. Faulty pressure relief valve. 3. Incorrect oil filter. 	<ol style="list-style-type: none"> 1. Change oil to correct viscosity. 2. Replace pressure relief valve. 3. Install correct oil filter.
------------------	---	--

WESTERBEKE'S 7A-1 and 11A-1 diesel engines each use a HURTH Model HBW 40 transmission. Installation, operation, maintenance and troubleshooting information for this transmission is included in the following instructions.

INSTALLATION

NOTE: When installing the transmission, make certain that shifting is not impeded by restricted movability of the cable or rod linkage, by unsuitably positioned guide sheaves, too small a bending radius or other restrictions. In order to mount a support for shift control cable connections, use the two threaded holes located above the cable bracket mounted on the gear housing. Refer to the WESTERBEKE Parts List.

Shaft Couplings

WESTERBEKE recommends a flexible connection between the transmission and the propeller shaft if the engine is flexibly mounted, in order to compensate for angular deflections. The installation of a special propeller thrust bearing is not required, since the propeller thrust will be absorbed by the transmission bearing, provided the value specified under SPECIFICATIONS is not exceeded. However, the output shaft should be protected from additional loads. Special care should be taken to prevent torsional vibration. When using a universal joint shaft, make certain to observe the manufacturers instructions.

Even with the engine solidly mounted, the use of a flexible coupling or DRIVESAVER* will reduce stress in the gearbox bearings caused by hull distortions, especially in wooden boats or where the distance between the transmission output flange and the stern gland is less than about 32 in. (812 mm).

Shift Control and Actuating Lever

The transmission is suitable for single lever remote control. Upon loosening the retaining screw, the actuating lever can be moved to any position required for the shift control (cable or rod linkage). Make certain that the actuating lever does not contact the actuating lever cover plate: the minimum distance between lever and cover should be 0.02 in. (0.5 mm), (see illustration).

⚠ Caution: The position of the mechanism behind the actuating lever is factory-adjusted to ensure equal actuating lever travel from Neutral position N to Reverse position A and Forward position B. If this mechanism is in any way tampered with, the transmission warranty will be void.

The control cable, or rod, should be arranged at a right angle to the actuating lever when in the neutral position. The neutral position of the shift lever on the control console should coincide with the neutral position of the actuating lever.

The shifting travel, as measured at the pivot points of the actuating lever between the neutral position and end positions A and B, should be at least 35 mm for the outer pivot point and 30 mm for the inner pivot point.

A greater amount of shift lever travel is in no way detrimental and is recommended. However, if the lever travel is shorter, proper clutch engagement might be impeded which, in turn, would mean premature wear, excessive heat generation and clutch plate failure. This would be indicated by slow clutch engagement or no engagement at all.

NOTE: Check for proper actuating lever travel at least each season.

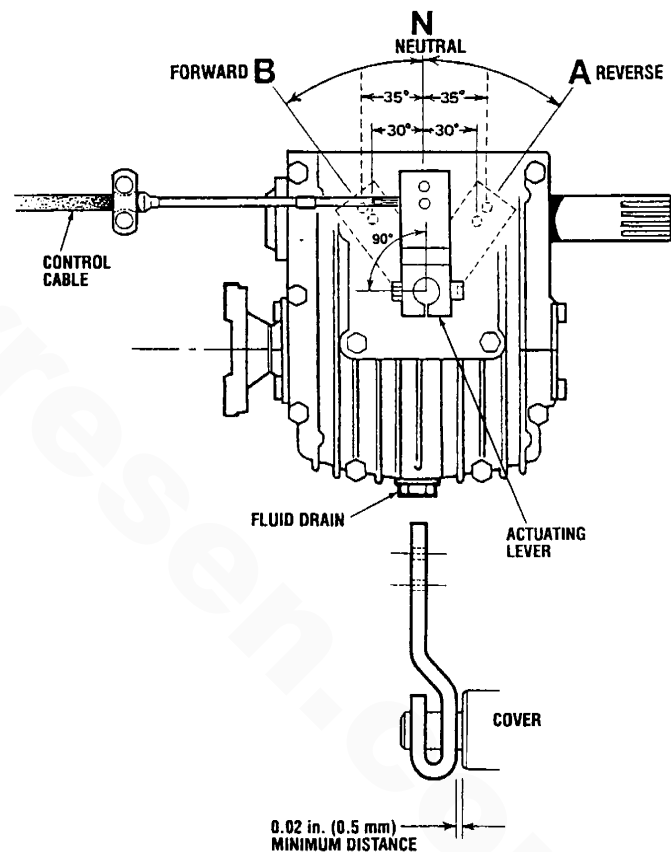

*DRIVESAVER is a product of Globe Marine, Rockland MA.



INITIAL OPERATION

All HBW maine transmissions are test-run on a test stand with the engine at the factory prior to delivery. For safety reasons the fluid is drained before shipment.

Fill the gearbox with Automatic Transmission Fluid (DEXTRON III). The fluid level should be up to the index mark on the dipstick. To check the fluid level, just insert the dipstick, do not screw it in. Screw the dipstick into the case after the fluid level is checked, and tighten. Do not forget the sealing ring under the hexhead of the dipstick. Check for leaks and make a visual inspection of the coupling, oil cooler and hoses, and shift cables.

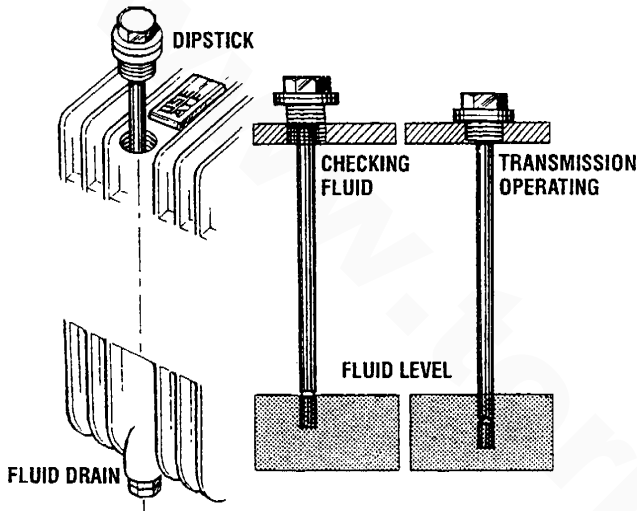

FLUID CHANGE

Change the fluid for the first time after about 25 hours of operation, then every 300 operating hours or at winterizing.

Removing the Fluid

Push a suction pump hose down through the dipstick hole to the bottom of the housing and suck out the fluid. If space allows, use the transmission drain. Remove the drain plug from the bottom of the transmission and allow the fluid to drain into a container, then reinstall the plug with its sealing washer. Wipe down the transmission and properly dispose of the used fluid. After running the engine, shut down and recheck the fluid level.

Drain plug torque: 20 – 25 ft/lb (27.7 – 34.6 Nm)

NOTE: When changing the fluid, take care not to lose the drain plug sealing washer. The drain plug will leak without this sealing washer.

WARNING: Never pull out the dipstick while the engine is running. Hot fluid will splash from the dipstick hole. This could cause sever burns.

LOCKING THE PROPELLER

Locking of the propeller shaft by an additional brake is not required: use the gear shift lever position opposite your direction of travel for this purpose. Never put the gear shift in the position corresponding to the direction of travel of the boat.

WHEN UNDER SAIL OR BEING TOWED

Rotation of the propeller without a load, such as when the boat is being sailed, being towed, or anchored in a river, as well as operation of the engine with the propeller stopped (for charging the battery), will have no detrimental effects on the transmission.

DAILY OPERATION

- Check the transmission fluid level.
- Visually check the gear shift linkage and transmission.
- Start the engine in neutral, allowing a few minutes at idle to warm the fluid.
- Shift into gear.

NOTE: Too low an idle speed will produce a chattering noise from the transmission gear and damper plate. In such cases the idle speed should be increased.

For additional information refer to the following text in this Transmission section: *SHAFT COUPLINGS, MAINTENANCE, and TRANSMISSION TROUBLESHOOTING.*

Operating Temperature

WARNING: if the transmission fluid temperature is too high, stop the engine immediately and check the transmission fluid.

Normal operating temperature of the transmission fluid should be in the range of 122° F (50° C) to 212° F (100° C). A maximum temperature of 266° F (130° C) may be only reached for a short time.

Make certain there is enough space around the transmission to provide good ventilation and cooling.

SPECIFICATIONS

TRANSMISSION	
General	HURTH HBW 40 Standard Transmission, case hardened helical gears, with a servo-operated multiple disc clutch.
Gear Ratio (optional)	2.05:1
Lubricating Fluid	ATF- type A or DEXTRON - II or III
Transmission Sump Capacity	0.37 qts (0.35 liters)
Propeller Shaft Direction of Rotation	Right hand-standard transmission

MAINTENANCE

Transmission maintenance is minimal. Keep the exterior housing clean, check the fluid level as part of your regular routine, and change the fluid every 300 operating hours.

Periodically inspect the transmission for leaks and corrosion. Lubricate the cable connections.

Lay-up/Winterize

Storage requires special care. Follow these procedures.

- Clean up the transmission and touch up unpainted areas (use heat resistant paint).
- Fill the transmission with *Dextron III ATF* fluid to prevent internal corrosion (extended storage only, twelve months or more).
- Loosen attaching hardware from the transmission output flange and propeller shaft coupling flange before removing the boat from the water. Separate the flanges and spray with lubricant.
- Inspect the gear shift cable, linkage, and attachments. Look for corrosion of the end fittings, cracks or cuts in the conduit, and bending of the cable rods. Lubricate all moving parts.

NOTE: *If the transmission is to be stored for a long time (twelve months or more), it should be topped off with fluid to prevent internal corrosion. Reduce the fluid level before putting the engine back into service.*

For additional information contact:

HURTH MARINE GEAR
ZF Industries
Marine US Headquarters
3131 SW 42nd Street
Fort Lauderdale, FL 33312
Tel.: (954)581-4040
Fax.: (954)581-4077

CONTROL CABLES

The majority of transmission difficulties arise as a result of problems with control cables rather than from problems with the transmission itself.

If you experience operating problems with the transmission, shut the engine down. First check the transmission fluid level, then have a helper move the cockpit shift lever through the full range — from neutral to full forward, back to neutral, into full reverse, and back to neutral — while you observe the actuating lever on the transmission. If the remote is stiff to operate, break the cable loose at the transmission and try again. If it is still stiff, check the cable for kinks or excessively tight bends, and check any linkage for binding.

A new cable and perhaps a new linkage mechanism may be needed. While the cable is loose, shift the transmission in and out of gear using the actuating lever on the side of the transmission to make sure there's no binding inside the case.

If the transmission passes these tests, crank the engine and have a helper put it in forward and reverse while you observe the propeller shaft; if the shaft isn't turning, the transmission needs professional attention. If it does turn but there's no thrust, check to see if you still have a propeller on the end of the shaft or, if you have a folding or feathering propeller, that it isn't stuck in the "no pitch" position.

NOTE: *If you suspect a major problem in your transmission, immediately contact your WESTERBEKE dealer or an authorized marine transmission facility.*

Problem	Probable Cause	Remedy
Transmission gears cannot be shifted. Fails to move into gear.	<ol style="list-style-type: none"> 1. Actuating lever is loose. 2. Shifting cable is broken, bent or unattached. Cable radius is too severe. 3. Actuating lever is binding against cover plate. 	<ol style="list-style-type: none"> 1. Tighten damping bolt on actuating lever. 2. Check the cable, reattach or replace. 3. Detach the shift cable and operate the actuating lever by hand. Clearance should be 0.02 in. (0.5 mm).
Transmission shifts into gear, but fails to propel the boat.	<ol style="list-style-type: none"> 1. Output coupling is not turning. 2. Propeller shaft is not turning. Output coupling is turning. 3. Output coupling and propeller shaft are both turning. 	<ol style="list-style-type: none"> 1. Transmission needs professional attention. 2. The coupling bolts are sheared or the coupling is slipping on the propeller shaft. Tighten or replace set screws, keys, pins and coupling bolts as necessary. 3. Inspect the propeller; it may be missing or damaged. A folding propeller may be jammed. A variable pitch propeller may be in "no pitch" position.
Delay of gear engagement or engages only after an increase in speed.	<ol style="list-style-type: none"> 1. Actuating lever travel N to B not equal to N to A. Refer to diagram. 2. Actuating lever travel is insufficient. 3. Actuating lever is binding against cover plate. 	<ol style="list-style-type: none"> 1. Adjust cover plate until the lever is exact mid position. Refer to actuating lever text and diagram. 2. Check actuating lever cable length. Refer to lever diagram. 3. Check clearance, adjust if necessary.
Chattering transmission noise, mainly at low engine speed.	<ol style="list-style-type: none"> 1. The engine or propeller generates torsional vibrations in the drive unit which produces a "chattering" noise in the transmission. 	<ol style="list-style-type: none"> 1. Mount a flexible coupling with another stiffness factor between the transmission coupling and the driveshaft. A higher stiffness factor might be sufficient. 2. Inspect the damper plate between the engine and the transmission. Replace if necessary.
Transmission noise becomes louder.	<ol style="list-style-type: none"> 1. Damage starting on flexible coupling due to wear or fatigue, possibly due to misalignment between engine and the drive shaft. 2. Beginning damage of bearings in transmission due to torsional vibrations, running without fluid, overload, wrong alignment of transmission, or excessive engine output. 	<ol style="list-style-type: none"> 1. Check alignment, inspect flexible coupling. If noise persists, inspect the damper plate between the transmission and the engine. Replace if necessary. 2. Transmission needs professional attention.
Boat fails to attain specified max. speed.	<ol style="list-style-type: none"> 1. Operating temperature is high. 	<ol style="list-style-type: none"> 1. Wrong type of fluid; use <i>ATF type A</i> or <i>DEXTRON II</i> or <i>III</i>. Check fluid level.
Oil leakage.	<ol style="list-style-type: none"> 1. Corrosion at radial sealing ring and shaft. Damaged sealing ring. 2. Misalignment of output flanges. 	<ol style="list-style-type: none"> 1. Transmission needs professional attention. 2. Check alignment. Must be within 0.003 in. (0.08 mm).



GENERAL

Many owners rely on their boatyards to prepare their craft, including engines and generators, for lay-up during the off season or for long periods of inactivity. Others prefer to accomplish lay-up preparation themselves.

The procedures which follow will allow you to perform your own lay-up and recommissioning, or you may use them as a check list if others do the procedures.

These procedures should afford your engine protection during lay-up and also help familiarize you with the maintenance needs of your engine.

If you have any questions regarding lay-up procedures, call your local servicing dealer; he will be more than willing to provide assistance.

PROPELLER SHAFT COUPLING

The transmission and propeller half couplings should always be opened up and the bolts removed when the boat is hauled out of the water or moved from land to water, and during storage in the cradle. The flexibility of the boat often puts a severe strain on the propeller shaft or coupling or both, while the boat is taken out or put in the water. In some cases, the shaft has actually been bent by these strains. This does not apply to small boats that are hauled out of the water when not in use, unless they have been dry for a considerable period of time.

LUBRICATING SYSTEM

With the engine warm, drain all the engine oil from the oil sump. Fill the sump with the correct amount of oil for your engine (refer to the *SPECIFICATIONS* section of this manual). Use an oil with an API specification of CF or CG-4. Run the engine and check for proper oil pressure and make sure there are no leaks.

⚠ Caution: Do not leave the engine's old engine oil in the sump over the lay-up period. Engine oil and combustion deposits combine to produce harmful chemicals which can reduce the life of your engine's internal parts.

FUEL SYSTEM

Top off your fuel tanks with No. 2 diesel fuel. Fuel additives such as *BIOBOR* AND *STA-BIL* should be added at this time to control algae and condition the fuel. Care should be taken that the additives used are compatible with the primary fuel filter/water separator used in the system. Change the filter element in your primary fuel filter/water separator, if the fuel system has one, and clean the separator sediment bowl. Reinstall and make certain there are no leaks. Clean up any spilled fuel.

Change the fuel filter elements on the engine (see *FUEL SYSTEM*) and bleed the fuel system, as needed. Start the engine and allow it to run for 5–10 minutes to make sure there is no air left in the fuel system. Check for any leaks that may have been created in the fuel system during this servicing, correcting them as needed. Operate the engine for 5–10 minutes. This will allow movement of the treated fuel through the injection equipment of the engine.

Long-Term Lay-Up Procedure (over 12 months)

For a long-term lay-up, follow the fuel system lay-up procedures described above, then do the following:

Disconnect the fuel supply line from the fuel tank at the fuel lift pump. Fill a suitable container with a 0.132 U.S. gallon (0.5 litre) mixture of 9/10 diesel fuel and 1/10 anti-corrosion oil. Connect a short suction pipe between the container and the fuel lift pump. Set the speed control lever to full load, set the automatic decompression device to its neutral position, then hand-crank the engine approximately 20 times. Put the speed control lever back to the idle position.

RAW WATER COOLING CIRCUIT

Remove the impeller from your raw water pump and allow the raw water in the cylinder head coolant chamber to drain out. Allow it to drain completely. Examine the impeller. Acquire a replacement, if needed, and a cover gasket. Do not replace the impeller (into the pump) until recommissioning, but replace the cover and gasket. Drain the water lift muffler.

AIR INTAKE & THROUGH-HULL EXHAUST

Remove the air intake silencer and place a clean cloth, lightly soaked in lubricating oil, in the air intake opening to block the opening. Do not shove the cloth out of sight (if it is not visible at recommissioning, and an attempt is made to start the engine, you may need the assistance of a servicing dealer). Make a note to remove the cloth prior to start-up. The through-hull exhaust port can be blocked in the same manner.

CYLINDER AND VALVES

To protect the cylinder and valves, remove the air intake silencer. Then spray fogging oil into the cylinder head air intake opening. Rotate the engine two revolutions using the hand crank. Spray fogging oil into the air intake again. Replace the air intake silencer.

If you anticipate a long lay-up period (12 months or more) WESTERBEKE recommends removing the fuel injector for access to the cylinder, then squirting light lubricating oil into the cylinder to prevent the piston rings from sticking to the cylinder walls. After squirting the oil, move the piston by a quick electric start or the hand crank to distribute the oil. Make sure you have replacements for the injector and return line sealing washers.



STARTER MOTOR

Lubrication and cleaning of the starter drive pinion is advisable. Make sure the battery connections are shut off before attempting to remove the starter. Take care in properly replacing any electrical connections removed from the starter.

BATTERIES

If batteries are to be left on board during the lay-up period, make sure they are fully charged, and will remain that way, to prevent them from freezing. If there is any doubt the batteries will not remain full charged, or that they will be subjected to severe environmental conditions, remove the batteries and store them in a warmer, more compatible environment.

⚠ WARNING: *Lead acid batteries emit hydrogen, a highly-explosive gas, which can be ignited by electrical arcing or a lighted cigarette, cigar, or pipe. Do not smoke or allow an open flame near the battery being serviced. Shut off all electrical equipment in the vicinity to prevent electrical arcing during servicing.*

TRANSMISSION

Check or change the fluid in the transmission as required. Wipe off grime and grease and touch up any unpainted areas. Protect the coupling and the output flange with an anti-corrosion coating. Check that the transmission vent is open.

For additional information, see *Lay-up/Winterize* in the *HURTH HBW TRANSMISSION* section.

SPARE PARTS

Lay-up time provides a good opportunity to inspect your WESTERBEKE engine to see if external items such as the drive belt or coolant hoses need replacement. Check your basic spares kit and order items not on hand, or replace those items used during the lay-up, such as filters. See *SUGGESTED SPARE PARTS*.

KEYSWITCH MAINTENANCE

Lubricate the keyswitch with *LOCKEZE* to ensure that the switch mechanism functions freely with no binding.

STORAGE

Thoroughly clean the outside of the engine, then store the engine in a dry place, protected against the weather.

RECOMMISSIONING

The recommissioning of your WESTERBEKE engine after a seasonal lay-up generally follows the same procedures as those described in the *PREPARATIONS FOR INITIAL START-UP* section regarding preparation for starting and normal starts. However, some of the lay-up procedures will need to be counteracted before starting the engine.

1. Remove the oil-soaked cloths from the air intake opening and the through-hull exhaust port.

2. Remove the raw water pump cover and gasket and discard the old gasket.

Install the raw water pump impeller that was removed during lay-up (or a replacement, if required). Install the raw water pump cover with a new cover gasket.

3. Reinstall the batteries that were removed during the lay-up, and reconnect the battery cables, making sure the terminals are clean and that the connections are tight. Check to make sure that the batteries are fully charged.

⚠ CAUTION: *Wear rubber gloves, a rubber apron and eye protection when servicing batteries. Lead acid batteries emit hydrogen, a highly explosive gas, which can be ignited by electrical arcing or a lighted cigarette, cigar or pipe. Do not smoke or allow an open flame near the battery being serviced. Shut off all electrical equipment in the vicinity to prevent electrical arcing during servicing.*

4. Start the engine in accordance with the *PREPARATIONS FOR INITIAL START-UP* and *STARTING/STOPPING PROCEDURE* sections of this manual.

7A-1 & 11A-1 TORQUE SPECIFICATIONS

Component	MODEL 7A-1			MODEL 11A-1		
	SPANNER SIZE (mm)	TIGHTENING TORQUE (Nm)		SPANNER SIZE (mm)	TIGHTENING TORQUE (Nm)	
		MIN.	MAX.		MIN.	MAX.
Cylinder head	13	30	33	17	52	56
Connecting rod	13	30	33	14	52	56
Cylinder head cover	13	8	12	13	8	12
Main bearing plate	13	30	33	13	30	33
Fuel lift pump	13	30	33	13	30	33
Fuel injection pump	13	30	33	13	30	33
Delivery valve holder-injection pump	14	34	39	14	34	39
High pressure fuel line-injection pump	17	18	22	17	18	22
High pressure fuel line-fuel injector	17	25	30	17	25	30
Injector clamp	10	8	12	13	20	23
Governor on crankshaft	14	55	60	14	55	60
Flywheel	36	216	226	46	390	410
Gear end cover	6	34	38	6	34	38
Push rod guide	4	8	10	4	8	10
Crank handle guide	10	8	12	10	8	12
Oil pump	5	16	20	5	16	20
Sump plate	cross-slotted	9	11	cross-slotted	9	11
Banjo bolt on fuel lift pump	17	25	35	17	25	35
Banjo bolt on tank	12	8	10	12	8	10
Rocker bracket	13	30	33	17	52	56
Oil filter	—	—	—	—	Hand-tighten	

BOLT HEAD MARKINGS

Bolt strength classes are embossed on the head of each bolt.

Customary (inch) bolts are identified by markings two to grade eight (strongest). The marks correspond to two marks less than the actual grade, i.e., a grade seven bolt will display five embossed marks.

Metric bolt class numbers identify bolts by their strength with 10.9 the strongest.

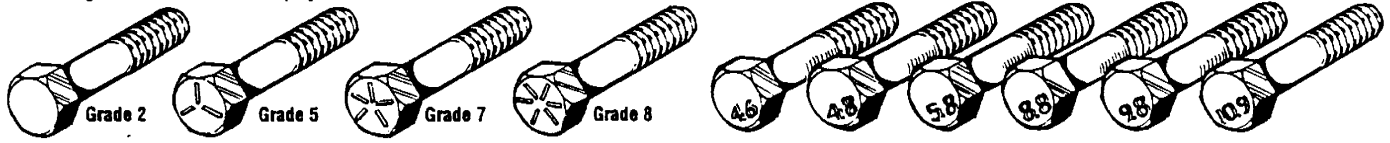

- NOTES:**
1. Use the torque values listed below when specific torque values are not available.
 2. These torques are based on clean, dry threads. Reduce torque by 10% when engine oil is used.
 3. Reduce torques by 30% or more, when threading capscrews into aluminum.

STANDARD BOLT & NUT TORQUE SPECIFICATIONS			
Capscrew Body Size (Inches) - (Thread)	SAE Grade 5 Torque Ft-Lb (Nm)	SAE Grade 6-7 Torque Ft-Lb (Nm)	SAE Grade 8 Torque Ft-Lb (Nm)
1/4 - 20 - 28	8 (11) 10 (14)	10 (14)	12 (16) 14 (19)
5/16 - 18 - 24	17 (23) 19 (26)	19 (26)	24 (33) 27 (37)
3/8 - 16 - 24	31 (42) 35 (47)	34 (46)	44 (60) 49 (66)
7/16 - 14 - 20	49 (66) 55 (75)	55 (75)	70 (95) 78 (106)
1/2 - 13 - 20	75 (102) 85 (115)	85 (115)	105 (142) 120 (163)
9/16 - 12 - 18	110 (149) 120 (163)	120 (163)	155 (210) 170 (231)
5/8 - 11 - 18	150 (203) 170 (231)	167 (226)	210 (285) 240 (325)
3/4 - 10 - 16	270 (366) 295 (400)	280 (380)	375 (508) 420 (569)
7/8 - 9 - 14	395 (536) 435 (590)	440 (597)	605 (820) 675 (915)
1 - 8 - 14	590 (800) 660 (895)	660 (895)	910 (1234) 990 (1342)

METRIC BOLT & NUT TORQUE SPECIFICATIONS					
Bolt Dia.	Wrench Size	Grade 4.6 Ft-Lb (Nm)	Grade 4.8 Ft-Lb (Nm)	Grade 8.8 - 9.8 Ft-Lb (Nm)	Grade 10.9 Ft-Lb (Nm)
M3	5.5 mm	0.3 (0.5)	0.5 (0.7)	1 (1.3)	1.5 (2)
M4	7 mm	0.8 (1.1)	1 (1.5)	2 (3)	3 (4.5)
M5	8 mm	1.5 (2.5)	2 (3)	4.5 (6)	6.5 (9)
M8	10 mm	3 (4)	4 (5.5)	7.5 (10)	11 (15)
M9	13 mm	7 (9.5)	10 (13)	18 (25)	35 (26)
M10	16 mm	14 (19)	18 (25)	37 (50)	55 (75)
M12	18 mm	26 (35)	33 (45)	63 (85)	97 (130)
M14	21 mm	37 (50)	55 (75)	103 (140)	151 (205)
M16	24 mm	59 (80)	85 (115)	159 (215)	232 (315)
M18	27 mm	81 (110)	118 (160)	225 (305)	321 (435)
M20	30 mm	118 (160)	166 (225)	321 (435)	457 (620)
M22	33 mm	159 (215)	225 (305)	435 (590)	620 (840)
M24	36 mm	203 (275)	288 (390)	553 (750)	789 (1070)
M27	41 mm	295 (400)	417 (565)	811 (1100)	1154 (1565)
M30	46 mm	402 (545)	568 (770)	1103 (1495)	1571 (2130)
M33	51 mm	546 (740)	774 (1050)	1500 (2035)	2139 (2900)
M36	55 mm	700 (950)	992 (1345)	1925 (2610)	2744 (3720)

SEALANTS & LUBRICANTS

GASKETS/SEALANTS

Oil based PERMATEX #2 and it's HIGH TACK equivalent are excellent all purpose sealers. They are effective in just about any joint in contact with coolant, raw water, oil or fuel.

A light coating of OIL or LIQUID TEFLON can be used on rubber gaskets and O-rings.

LOCTITE hydraulic red sealant should be used on oil adapter hoses and the oil filter assembly.

Coat both surfaces of the oil pan gasket with high temp RED SILICONE sealer.

When installing gaskets that seal around water (coolant) passages, coat both sides with WHITE SILICONE grease.

High-copper ADHESIVE SPRAYS are useful for holding gaskets in position during assembly.

Specialized gasket sealers such as HYLOMAR work well in applications requiring non-hardening properties. HYLOMAR is particularly effective on copper cylinder-head gaskets as it resists fuel, oil and water.

Use LIQUID TEFLON for sealing pipe plugs and fillings that connect coolant passages. **Do not use tape sealants!**

BOLTS & FASTENERS/ASSEMBLIES

Lightly oil head bolts and other fasteners as you assemble them. Bolts and plugs that penetrate the water jacket should be sealed with PERMATEX #2 or HIGH TACK.

When assembling the flywheel, coat the bolt threads with LOCTITE blue.

Anti-seize compounds and thread locking adhesives such as LOCTITE protect threaded components yet allows them to come apart when necessary. LOCTITE offers levels of locking according to the job.

LITHIUM based grease is waterproof, ideal for water pump bearings and stuffing boxes.

Heavily oil all sliding and reciprocating components when assembling. **Always use clean engine oil!**



METRIC CONVERSIONS

INCHES TO MILLIMETERS

MILLIMETERS TO INCHES

Inches	mm	Inches	mm	mm	Inches	mm	Inches
1	25.40	15	381.00	1	0.0394	15	0.5906
2	50.80	20	508.00	2	0.0787	20	0.7874
3	76.20	25	635.00	3	0.1181	25	0.9843
4	101.60	30	762.00	4	0.1575	30	1.1811
5	127.00	35	889.00	5	0.1969	35	1.3780
10	254.00	40	1016.00	10	0.3937	40	1.5748

10 MILLIMETERS = 1 CENTIMETER, 100 CENTIMETERS = 1 METER = 39.37 INCHES (3.3 FEET)

INCHES TO METERS

METERS TO INCHES

Inches	Meters	Inches	Meters	Meters	Inches	Meters	Inches
1	0.0254	7	0.1778	0.1	3.937	0.7	27.559
2	0.0508	8	0.2032	0.2	7.874	0.8	31.496
3	0.0762	9	0.2286	0.3	11.811	0.9	35.433
4	0.1016	10	0.2540	0.4	15.748	1.0	39.370
5	0.1270	11	0.2794	0.5	19.685	1.1	43.307
6	0.1524	12	0.3048	0.6	23.622	1.2	47.244

TO CONVERT METERS TO CENTIMETERS, MOVE DECIMAL POINT TWO PLACES TO THE RIGHT

YARDS TO METERS

METERS TO YARDS

Yards	Meters	Yards	Meters	Meters	Yards	Meters	Yards
1	0.91440	6	5.48640	1	1.09361	6	6.56168
2	1.82880	7	6.40080	2	2.18723	7	7.65529
3	2.74320	8	7.31520	3	3.28084	8	8.74891
4	3.65760	9	8.22960	4	4.37445	9	9.84252
5	4.57200	10	9.14400	5	5.46807	10	10.93614

MOVE DECIMAL POINT FOR HIGHER VALUES — e.g. 6,000 METERS = 6,561.68 YARDS

POUNDS TO KILOGRAMS

KILOGRAMS TO POUNDS

lb	kg	lb	kg	kg	lb	kg	lb
1	0.454	6	2.722	1	2.205	6	13.228
2	0.907	7	3.175	2	4.409	7	15.432
3	1.361	8	3.629	3	6.614	8	17.637
4	1.814	9	4.082	4	8.818	9	19.842
5	2.268	10	4.536	5	11.023	10	22.046

GALLONS TO LITERS

LITERS TO GALLONS

Gallons	Liters	Gallons	Liters	Liters	Gallons	Liters	Gallons
1	3.79	10	37.86	1	0.26	60	15.66
2	7.57	20	75.71	2	0.53	90	23.77
3	11.36	30	113.57	5	1.32	120	31.32
4	15.14	40	151.42	10	2.64	150	39.62
5	18.93	50	189.28	20	5.28	180	47.54

PINTS TO LITERS

LITERS TO PINTS

Pints	Liters	Pints	Liters	Liters	Pints	Liters	Pints
1	0.47	6	2.84	1	2.11	6	12.68
2	0.95	7	3.31	2	4.23	7	14.79
3	1.42	8	3.79	3	6.34	8	16.91
4	1.89	9	4.26	4	8.45	9	19.02
5	2.37	10	4.73	5	10.57	10	21.13

TEMPERATURE

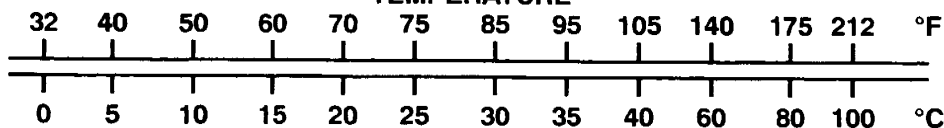

LENGTH-DISTANCE

Inches (in) x 25.4 = Millimeters (mm) x .0394 = Inches
Feet (ft) x .305 = Meters (m) x 3.281 = Feet
Miles x 1.609 = Kilometers (km) x .0621 = Miles

VOLUME

Cubic Inches (in³) x 16.387 = Cubic Centimeters x .061 = in³
Imperial Pints (IMP pt) x .568 = Liters (L) x 1.76 = IMP pt
Imperial Quarts (IMP qt) x 1.137 = Liters (L) x .88 = IMP qt
Imperial Gallons (IMP gal) x 4.546 = Liters (L) x .22 = IMP gal
Imperial Quarts (IMP qt) x 1.201 = US Quarts (US qt) x .833 = IMP qt
Imperial Gallons (IMP gal) x 1.201 = US Gallons (US gal) x .833 = IMP gal
Fluid Ounces x 29.573 = Milliliters x .034 = Ounces
US Pints (US pt) x .473 = Liters(L) x 2.113 = Pints
US Quarts (US qt) x .946 = Liters (L) x 1.057 = Quarts
US Gallons (US gal) x 3.785 = Liters (L) x .264 = Gallons

MASS-WEIGHT

Ounces (oz) x 28.35 = Grams (g) x .035 = Ounces
Pounds (lb) x .454 = Kilograms (kg) x 2.205 = Pounds

PRESSURE

Pounds Per Sq In (psi) x 6.895 = Kilopascals (kPa) x .145 = psi
Inches of Mercury (Hg) x .4912 = psi x 2.036 = Hg
Inches of Mercury (Hg) x 3.377 = Kilopascals (kPa) x .2961 = Hg
Inches of Water (H₂O) x .07355 = Inches of Mercury x 13.783 = H₂O
Inches of Water (H₂O) x .03613 = psi x 27.684 = H₂O
Inches of Water (H₂O) x .248 = Kilopascals (kPa) x 4.026 = H₂O

TORQUE

Pounds-Force Inches (in-lb) x .113 = Newton Meters (Nm) x 8.85 = in-lb
Pounds-Force Feet (ft-lb) x 1.356 = Newton Meters (Nm) x .738 = ft-lb

VELOCITY

Miles Per Hour (MPH) x 1.609 = Kilometers Per Hour (KPH) x .621 = MPH

POWER

Horsepower (Hp) x .745 = Kilowatts (Kw) x 1.34 = MPH

FUEL CONSUMPTION

Miles Per Hour IMP (MPG) x .354 = Kilometers Per Liter (Km/L)
Kilometers Per Liter (Km/L) x 2.352 = IMP MPG
Miles Per Gallons US (MPG) x .425 = Kilometers Per Liter (Km/L)
Kilometers Per Liter (Km/L) x 2.352 = US MPG

TEMPERATURE

Degree Fahrenheit (°F) = (°C X 1.8) + 32
Degree Celsius (°C) = (°F - 32) x .56



SUGGESTED SPARE PARTS KITS

Carry only Genuine WESTERBEKE Spare Parts

SPARE PARTS KITS

WESTERBEKE offers two Spare Parts Kits, each packaged in a rugged hinged toolbox. Kit "A" includes the basic spares. Kit "B" is for more extensive off-shore cruising.

Kit "A" includes:

- Drive Belt
- Raw Water Pump Impeller and Gasket
- Fuel Filter
- Fuel Lift Pump Screens (2) and Gasket
- Oil Filter (Model 10A-1 only)
- Fuel Hardware Kit (to fix a leak)
- Air Intake Filter

Kit "B" includes:

- Drive Belt
- Raw Water Pump Impeller and Gasket
- Raw Water Pump Repair Kit
- Fuel Filter
- Fuel Lift Pump Screens (2) and Gasket
- Oil Filter (Model 10A-1 only)
- Fuel Hardware Kit (to fix a leak)
- Thermostat Kit
- Complete Gasket Kit
- Fuel Injector
- Air Intake Filter

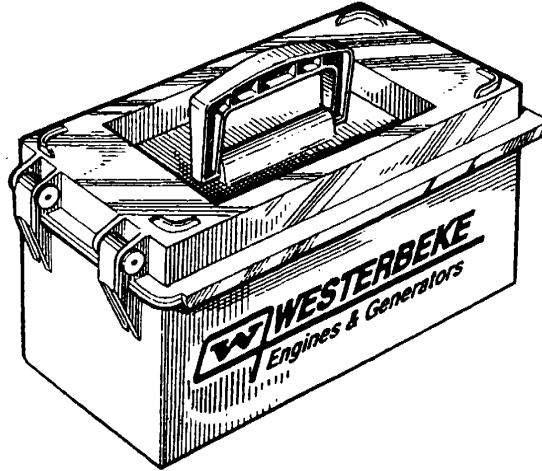

www.torresen.com

