

# Yanmar type 4LHA-HTZP

## The Powerful Gem

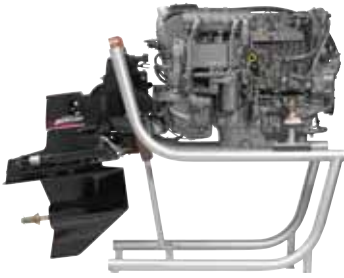

<b>Configuration</b>	4-stroke, vertical, water cooled diesel engine
<b>Maximum output at crankshaft</b>	* 118 kW (160 mhp) / 3300 rpm ** 113 kW (154 mhp) / 3300 rpm
<b>Continuous rating output at crankshaft</b>	91 kW (124 mhp) / 3100 rpm
<b>Displacement</b>	3.455 L (211 cu in)
<b>Bore x stroke</b>	100 mm x 110 mm (3.94 in x 4.33 in)
<b>Cylinders</b>	4 in line
<b>Combustion system</b>	Direct injection
<b>Aspiration</b>	Turbocharged with intercooler
<b>Starting system</b>	Electrical starting 12 V - 2.5 kW
<b>Alternator</b>	12 V - 60 A (80 A optional)
<b>Cooling system</b>	Fresh water cooling by centrifugal fresh water pump and rubber impeller seawater pump
<b>Lubrication system</b>	Enclosed, forced lubricating system
<b>Direction of rotation (crankshaft)</b>	Counter clockwise viewed from stern
<b>Dry weight without sterndrive</b>	388 kg (855 lbs)
<b>Environmental</b>	BSO II, IMO, EMC and RCD compliant
<b>Engine mounting</b>	Rubber type flexible mounting

NOTE: Fuel condition: Density at 15°C = 0.842g/cm<sup>3</sup>; 1 mhp = 1 PS = 0.7355 kW = 0.9863 bhp

\* Fuel temperature 25°C at the inlet of the fuel injection pump (ISO 3046-1)

\*\* Fuel temperature 40°C at the inlet of the fuel injection pump (ISO 8665)

Dimensions (For detailed line-drawings, please refer to our web-site: [www.yanmarmarine.com](http://www.yanmarmarine.com))

### Rear view

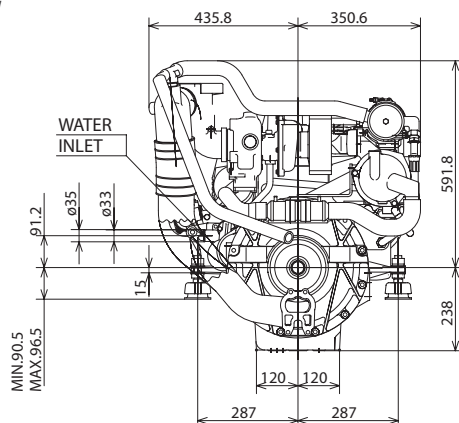

### Right side view

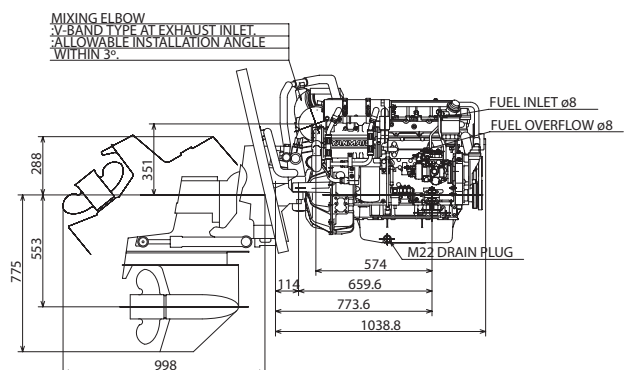

4LHA-HTZP w/ Bravo2 Sterndrive

## Performance Curves (Output is according ISO 8665 - Output includes +/- 3% tolerance)

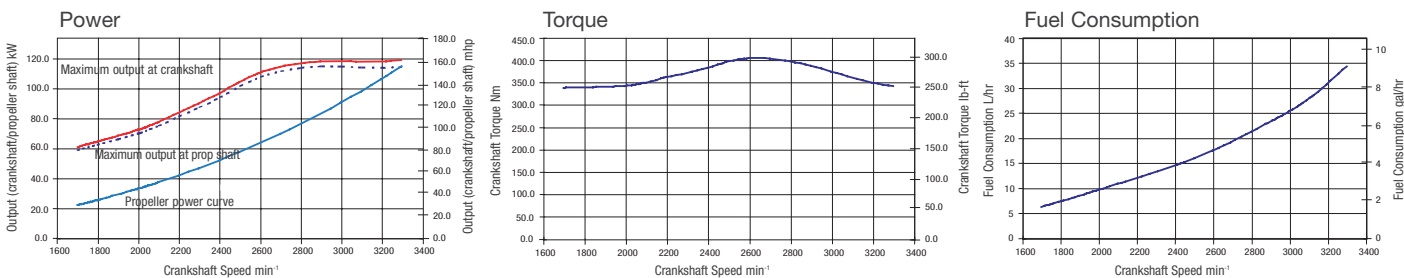

## Mercuriser Sterndrive set Engine \*\*\*

Model	Mercuriser Bravo Sterndrive series													
Type	Bravo X-1			Bravo X-2				Bravo X-3						
Dry weight	88 kg (184 lbs)			94 kg (207 lbs)				98 kg (216 lbs)						
Reduction ratio (fwd/asn)	1,36/1,36	1,50/1,50	1,65/1,65	1,50/1,50	1,65/1,65	1,81/1,81	2,00/2,00	2,20/2,20	1,36/1,36	1,50/1,50	1,65/1,65	1,81/1,81	2,00/2,00	2,20/2,20
Propeller speed (fwd/asn)	2279/2279	2067/2067	1879/1879	2067/2067	1879/1879	1713/1713	1550/1550	1409/1409	2279/2279	2067/2067	1879/1879	1713/1713	1550/1550	1409/1409
Direction of rotation (propeller shaft - fwd)	Clockwise & counter clockwise viewed from stern			Clockwise & counter clockwise viewed from stern				Clockwise & counter clockwise viewed from stern						
Dry weight engine and sterndrive	476 kg (1049 lbs)			482 kg (1063 lbs)				486 kg (1072 lbs)						
Length engine and sterndrive	2037 mm (80 in)			2124 mm (84 in)				2143 mm (84 in)						

1. Inner and outer transome surface must be parallel within 3mm in area covered by transome plates and remain within transome thickness limits.
2. Area covered by gimbal housing assembly must be flat to within 1.6mm.
3. Area covered by inner transome plate must be flat to within 3.2mm.
4. Transome angle: 13° to 16°

## Instrument Panels

### New B-type Panel

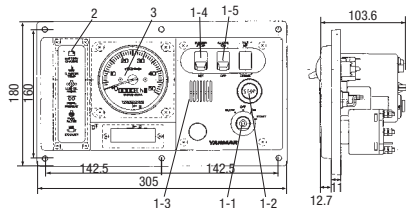

### New C-type Panel

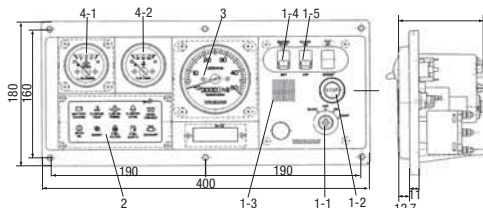

### New D-type Panel

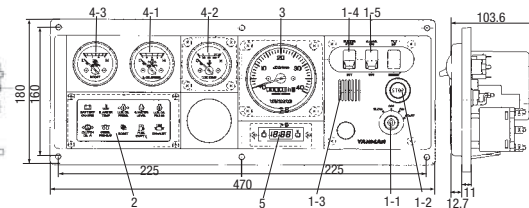

Function	Type of instrument panel		
	New B-type Panel	New C-type Panel	New D-type Panel
① <b>Switch unit</b>			
1-1 Key switch for GLOW/OFF/ON/START (4-position switch)	O	O	O
1-2 Engine stop switch	O	O	O
1-3 Alarm buzzer (C.W. Temp., L.O. Pressure)	O	O	O
1-4 Alarm buzzer stop switch	O	O	O
1-5 Illumination switch for meters	O	O	O
② <b>Alarm lamp unit</b>			
Battery not charging	O	O	O
C.W. high temperature	O	O	O
L.O. low pressure	O	O	O
③ <b>Tachometer with hour meter</b>	O	O	O
④ <b>Sub meter unit</b>	O	O	O
4-1 L.O. pressure meter	X	O	O
4-2 C.W. Temperature meter	X	O	O
4-3 Boost meter (turbo)	X	X	O
⑤ <b>Quartz clock</b>	X	X	O

Note: O = Equipped on panel X = Not equipped on panel

## Accessories

### Standard Package

- Standard Package
- Sensor for New B-type, New C-type or New D-type instrument panel
- Dry exhaust mixing elbow, U-type (high riser)

- Flexible mounts
- Water separator

### Optional

- Analog (New B-type, New C-type and New D-type) instrument panels
- Lub oil evacuation pump
- Remote Oil filter (Oppiste side)
- 12V/80A alternator (instead of 60A)

Texts and illustrations are not binding. Yanmar Marine reserves the right to introduce adaptations without prior notification.