

Yanmar type 8SY-STP

The Powerful Gem



Configuration	4-stroke, vertical, water cooled diesel engine
Maximum output at crankshaft	** 662 kW (900 hp) / 2300 rpm
Continuous rating output at crankshaft	503 kW (655 hp) / 2100 rpm
Displacement	15.6 L (952 cu in)
Bore x stroke	127 mm x 154 mm (5.0 in x 6.1 in)
Cylinders	V8-type 90°
Combustion system	Direct injection
Aspiration	Turbocharged with charge air cooler
Starting system	Electric starting 24 V - 6.7 kW (2 pole)
Alternator	24 V - 140 A (2 pole)
Cooling system	Fresh water cooling by centrifugal fresh water pump and rubber impeller seawater pump
Lubrication system	Enclosed, forced lubricating system
Direction of rotation (crankshaft)	Counter clockwise viewed from stern
Dry weight without gear	1650 kg (3650 lbs)
Environmental	EPA II, BSO II, SAV, EMC compliant and will meet the 2003/44/EC emission requirements effective from 2006
Engine mounting	Rubber type flexible mounting

NOTE: Fuel condition: Density at 15°C = 0.860 g/cm³; 1 hp = 0.7355 kW

**Fuel temperature 40°C at the inlet of the fuel injection pump (ISO 8665)

Dimensions (For detailed line-drawings, please refer to our web-site: www.yanmarmarine.com)

Rear view

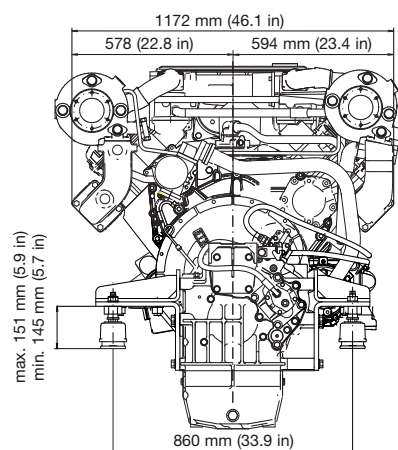

Right side view

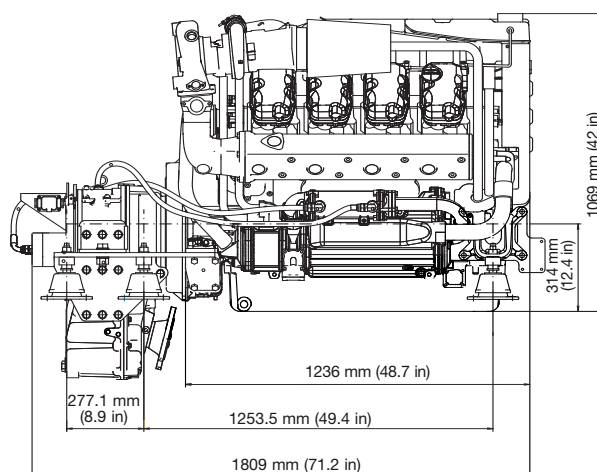

8SY-STP w/ TD MG 5114 IV marine gear

Performance Curves (Output is according ISO 8665 - Output includes +/- 3% tolerance)

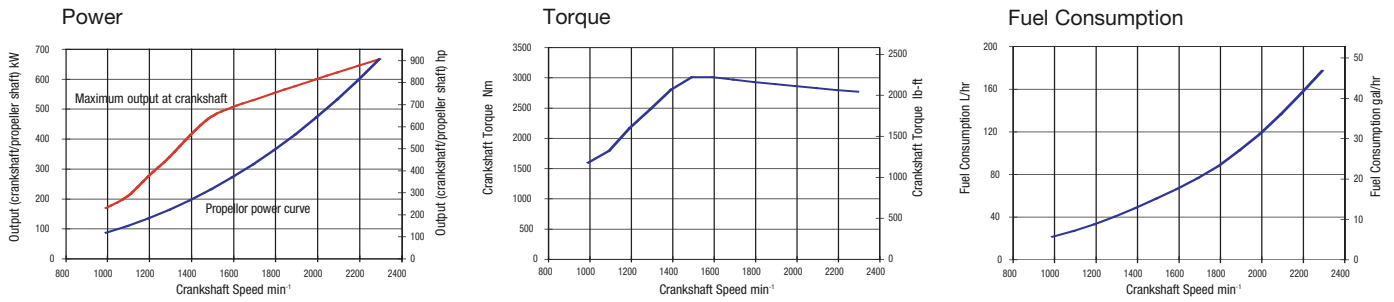

Marine gear (example) ***

Model	ZF 350A		TD MG 5114-A		
Type	hydraulic		hydraulic		
Dry weight	256 kg (564 lbs)		206 kg (454 lbs)		
Reduction ratio (fwd)	2.1	2.6	1.5	1.9	2.5
Propeller speed (fwd)	950	808	1400	1105	840
Direction of rotation (propeller shaft - fwd)	Clockwise & counter clockwise viewed from stern		Clockwise & counter clockwise viewed from stern		
Dry weight engine and gear/drive	1906 kg (4202 lbs)		1856 kg (4092 lbs)		
Length engine and gear/drive	1860 mm (73 in)		1809 mm (71 in)		

*** Gear also available in; ZF350V (V-drive) reduction ratio: 2.1, TD MG 5114 IV (V-drive) reduction ratio: 2

*** Other marine gearboxes and configurations available upon request. Contact your local supplier for more information.

Instrument Panels

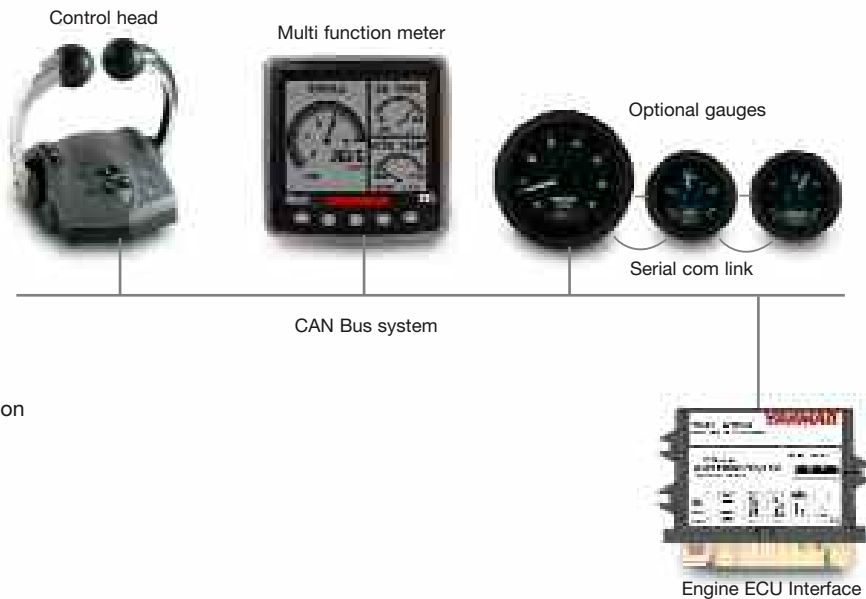

Optional LCD panel display:

- engine information
- maintenance information
- diagnosis messages

Accessories

Standard Package

- Alternator
- Protection cover for belt transmission
- Transmission oil cooler

- Water level sensor
- Engine control harness

- Engine control components including:
 - Control lever
 - LCD display
 - Backup throttle control system

Optional

- Dual station control elements
- Extra LCD display
- Various engine monitoring gauges

- Electric oil draining pump
- Crankshaft pulley
- Additional alternator

- Engine heater
- Extra rear PTO
- Hydraulic pump
- Exhaust mixing elbow

Texts and illustrations are not binding. Yanmar Marine reserves the right to introduce adaptations without prior notification.