

Midrange End Controls

Harken® Midrange traveler controls allow installation of 2:1 to 4:1 purchases. Assemblies secure to the track eliminating additional holes. Tough one-piece bases and cam arms are machined from a single piece of aluminum. Compact, high-strength Carbo AirBlock® components combined with a Carbo-Cam® cleats keep traveler weight minimal. For angled cleating, install the 380 X-Treme Angle Fairlead.

Use 1620 double-sheave ESP end controls for cabintop travelers where lines lead to the aft edge of the cabintop. Use the 1623 car control for a 3:1 purchase, the 1845 (see page 131) for a 4:1 purchase. Contact Harken® to order special length 1618 track with mounting holes for 1620 end controls.

End controls feature 40 mm Carbo AirBlock® sheaves with free-running Teflon® ball bearings

Installs with single screw

Dual shock absorbers cushion car impact

Integral bar for dead-ending control line



1631



1620



1632



1633



1642

Control Purchase Recommendations

Sail area				
End-boom sheeting		Mid-boom sheeting		Purchase
ft²	m²	ft²	m²	
Under 140	Under 13	Under 125	Under 12	2:1
140 — 235	13 — 22	125 — 200	12 — 19	3:1
235 — 275	22 — 25	200 — 250	19 — 23	4:1

Part No.	Description	Sheave Ø		Length		Width		Weight		Max line Ø		Height above track		Safe working load		Breaking strength		Purchase
		in	mm	in	mm	in	mm	oz	g	in	mm	in	mm	lb	kg	lb	kg	
1620	ESP Double sheave (pair)‡‡	1 9/16	40	5 1/2	140	1 9/16	40	16	454	3/8	10	1 9/16	40	600	272	1500	680	3:1/4:1
1631	Single sheave (pair)***	1 9/16	40	4 1/2	114	1 15/16	49	20	574	3/8	10	1 15/16	33	350	159	875	397	2:1/3:1
1632	Double sheave (pair)***	1 9/16	40	4 1/2	114	1 15/16	49	26	730	3/8	10	2	50	700	318	1750	794	3:1/4:1
1633	Double sheave/365 Carbo-Cam® (pair)***	1 9/16	40	4 1/2	114	3 15/16	100	36	1020	3/8	10	2	50	600	272	1500	680	3:1/4:1
1642	Pinstop‡	—	—	2 5/16	59	1 15/16	49	4.8	136	—	—	1 1/16	33	—	—	—	—	—

Fits Midrange track ***Includes 3/16" (8 mm) RH fasteners ‡Requires 1617 track ‡‡Requires special track

Track Risers

Use 1849 risers for mid-boom travelers that must clear companionway hatches. Risers fit most cabintops and articulate for use with either straight or curved track. Sold in pairs.

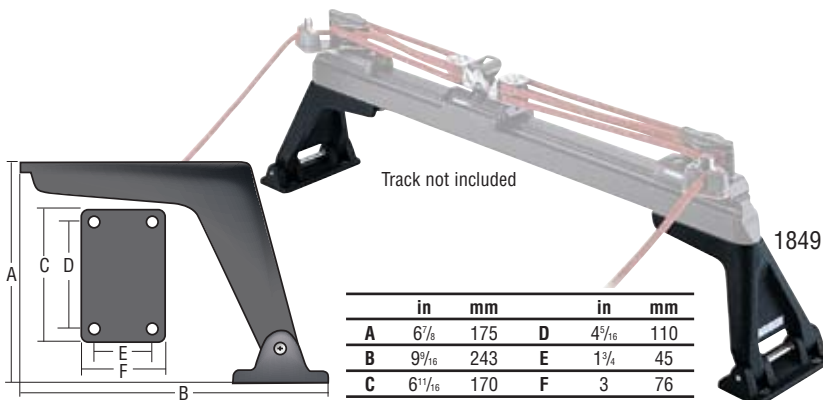

Track not included

1849

	in	mm		in	mm
A	6 7/8	175	D	4 1/16	110
B	9 9/16	243	E	1 1/4	45
C	6 11/16	170	F	3	76

Part No.	Description	Fits	Weight	
			oz	g
1849	Track riser (pair)	1618/3156	131.2	3720