

# TECHNICAL MANUAL

## WESTERBEKE 50 Marine Diesel Engine

**Publication #23156**

Edition Two

January 1981



# TECHNICAL MANUAL

## WESTERBEKE 50 Marine Diesel Engine

**Publication #23156**

Edition Two

January 1981



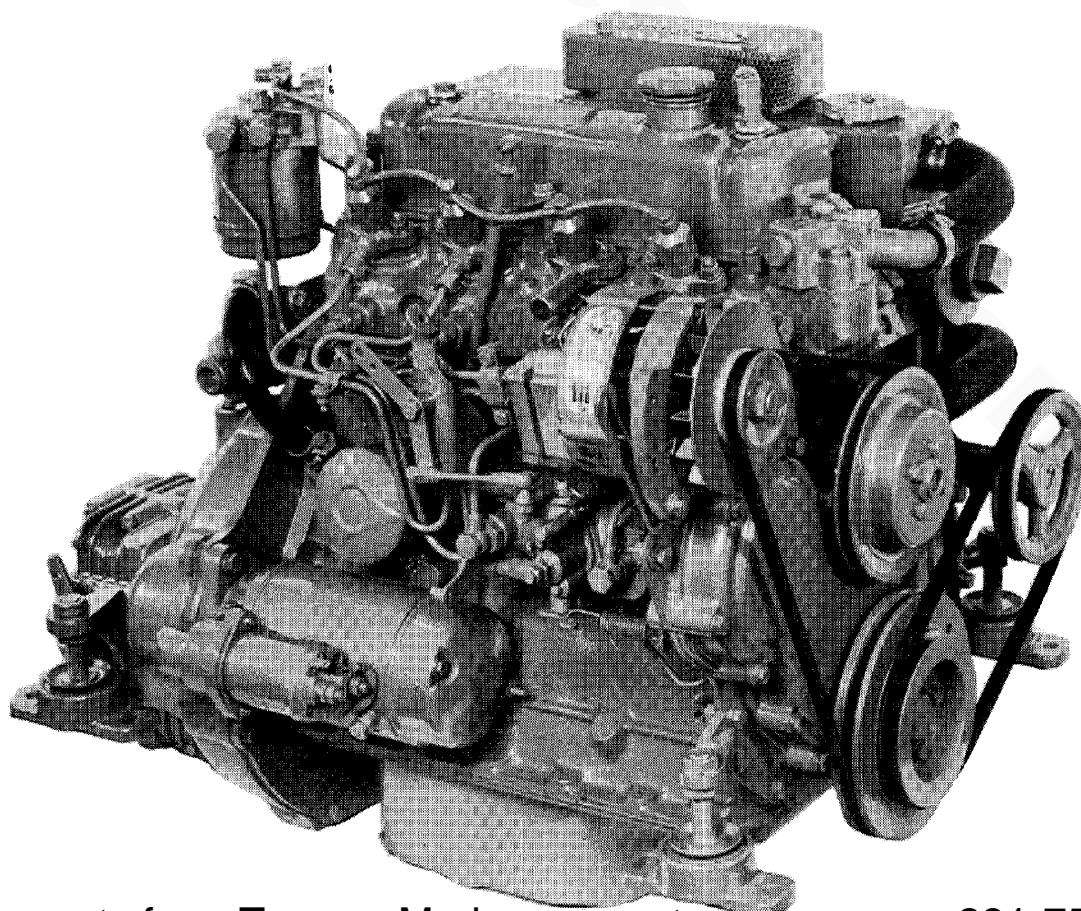
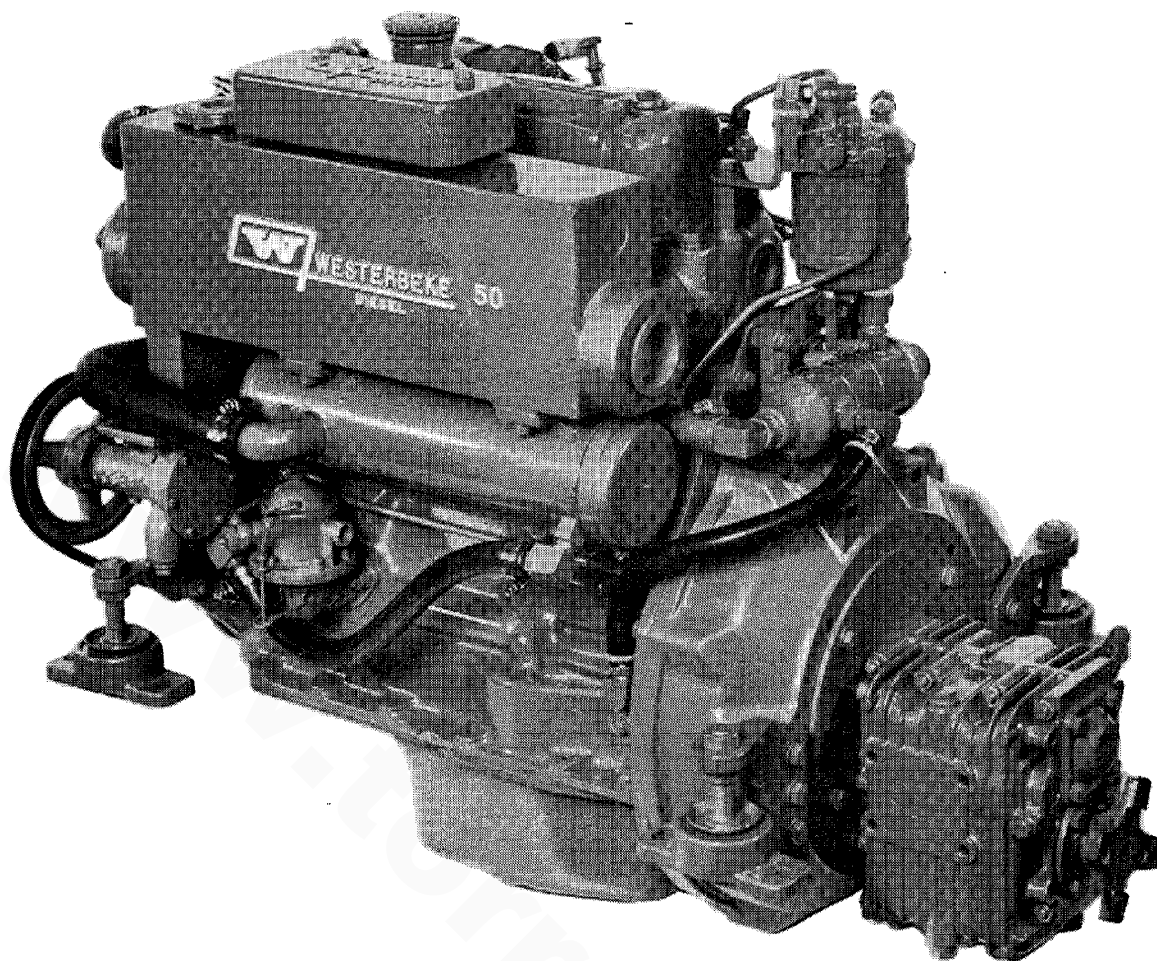

## INTRODUCTION

### IMPORTANT

THIS MANUAL IS A DETAILED GUIDE TO THE INSTALLATION, START-UP, OPERATION AND MAINTENANCE OF YOUR WESTERBEKE MARINE DIESEL ENGINE. THE INFORMATION IT CONTAINS IS VITAL TO THE ENGINE'S DEPENDABLE, LONG TERM OPERATION.

READ IT !

KEEP IT IN A SAFE PLACE !

KEEP IT HANDY FOR REFERENCE AT ALL TIMES !

FAILURE TO DO SO WILL INVITE SERIOUS RISK, NOT ONLY TO YOUR INVESTMENT BUT YOUR SAFETY AS WELL.

### UNDERSTANDING THE DIESEL....

The diesel engine closely resembles the gasoline engine inasmuch as the mechanism is essentially the same. Its cylinders are arranged above its closed crankcase; its crankshaft is of the same general type as that of a gasoline engine; it has the same sort of valves, camshaft, pistons, connecting rods, lubricating system and reverse and reduction gear.

Therefore, it follows to a great extent that a diesel engine requires the same preventative maintenance as that which any intelligent operator would give to a gasoline engine. The most important factors are proper maintenance of the fuel, lubricating and cooling systems. Replacement of fuel and lubricating filter elements at the time periods specified is a must, and frequent checking for contamination (i.e. water, sediment, etc.) in the fuel system is also essential. Another important factor is the use of the same brand of "high detergent" diesel lubricating oil designed specifically for diesel engines.

The diesel engine does differ from the gasoline engine, however, in the method of handling and firing its fuel. The carburetor and ignition systems are done away with and in their place is a single component - the Fuel Injection Pump - which performs the function of both.

Unremitting care and attention at the factory have resulted in a Westerbeke engine capable of many thousands of hours of dependable service. What the manufacturer cannot control, however, is the treatment it receives in service. This part rests with you!

### ORDERING PARTS

Whenever replacement parts are needed, always include the complete part description and part number (see separate Parts List furnished, if not part of this publication). Be sure to include the engine's model and serial number. Also, be sure to insist upon Westerbeke factory packaged parts, because "will fit" parts are frequently not made to the same specifications as original equipment.

### GENERATOR SETS

Westerbeke diesels are used for both the propulsion of boats and for generating electrical power. For generator set applications, all details of this Manual apply, except in regard to certain portions of the Installation, Operation and Maintenance sections. Additional information is provided in the section titled Generator Sets, Section T.

## YOUR NOTES

[www.torresen.com](http://www.torresen.com)

# INSTALLATION

## FOREWORD

Since the boats in which these engines are used are many and varied, details of engine installation are equally so. It is not the purpose of this section to advise boatyards and engine installers on the generally well understood and well developed procedures for installation of engines. However, the following outline of general procedure is included because it is valuable in explaining the functions of each component, the reasons why, the precautions to be watched and the relationship of the installation to the operation of the engine. There are details of the installation which should have a periodic check and of which the operator should have a thorough understanding to insure good operating conditions for the engine and correct procedure for its servicing.

## INSPECTION OF EQUIPMENT

The engine is shipped from the factory mounted securely and properly crated. Accessory equipment is shipped in a separate small box, usually packed with the engine crate.

Before accepting shipment from the transportation company, the crate should be opened and an inspection made for concealed damage. If either visible or concealed damage is noted, you should require the delivering agent to sign "Received in damaged condition". Also check contents of the shipment against the packing list and make sure note is made of any discrepancies. This is your protection against loss or damage. Claims for loss or damage must be made to the carrier, not to J. H. Westerbeke Corporation.

## RIGGING AND LIFTING

The engine is fitted with lifting rings.

Rope or chain slings should be attached to the rings and the engine lifted by means of tackle attached to this sling. The lifting rings have been designed to carry the full weight of the engine; therefore, auxiliary slings are not required or desired.

**CAUTION:** Slings must not be so short as to place the engine lifting eyes in significant sheer stress. Strain on the engine lifting eyes must not be in excess of 10° from the vertical. A spacer bar must be placed between the two lifting eyes, if supported by valve cover studs.

The general rule in moving engines is to see that all equipment used is amply strong and firmly fixed in place. Move the engine a little at a time and see that it is firmly supported. Eliminate possibility of accidents by avoiding haste. Do not lift from the propeller coupling, or pry against this with crowbar, as you may distort the coupling.

In some cases it may be necessary to lift the engine in other than the regular horizontal position. It may be that the engine must be lowered endwise through a small hatchway which cannot be made larger. If the opening is extremely restricted, it is possible to reduce, to some extent, the outside clearances such as generator, cooling piping, water tank, filters, mounting lugs, etc. This accessory equipment should be removed by a competent mechanic and special care should be

taken to avoid damage to any exposed parts and to avoid dirt entering openings. The parts which have been removed should be returned to position as soon as the restriction has been passed.

In case it is necessary to hoist the engine either front end upwards or reverse gear end upwards, the attachment of slings must be done very carefully to avoid the possibility of damage to the parts on which the weight may bear. It is best if special rigging work be done by someone experienced and competent in the handling of heavy machinery.

#### ENGINE BOLTS

It is recommended that bronze hanger bolts of appropriate size be used through the engine flexible mounts. Lag screws are less preferred because their hold on the wood is weakened every time they are moved, whereas the lag bolt stays in position and the nut on top is used to tighten the engine down or is removed to permit the engine to be lifted. The bolt itself stays in position at all times, as a stud, and the bond between the bolt and the wood is not weakened by its removal.

#### FOUNDATION FOR ENGINE

A good engine bed contributes much toward the satisfactory operation of the engine. The engine bed must be of rigid construction and neither deflect nor twist when subjected to the engine weight or the position the boat may have to take under the effects of rough seas. The bed must keep the engine within one or two thousandths of an inch of this position at all times. It has to withstand the forward push of the propeller which is applied to the propeller shaft, to the thrust washer bearing in the engine and finally to the engine bolts and engine bed.

In fiberglass hulls, we recommend that similar wooden stringers as in wooden hulls be formed and fitted, then glassed to the hull securely. This allows hanger bolts to be installed firmly in wood, thus reducing noise and transmitted vibration.

The temptation to install the engine on a pair of fiberglass "angle irons" should be resisted. Such construction will allow engine vibrations to pass through to the hull. Flexible mounts require a firm foundation against which to react if they are to do their job. When possible, follow bed design "A" and avoid bed design "B".

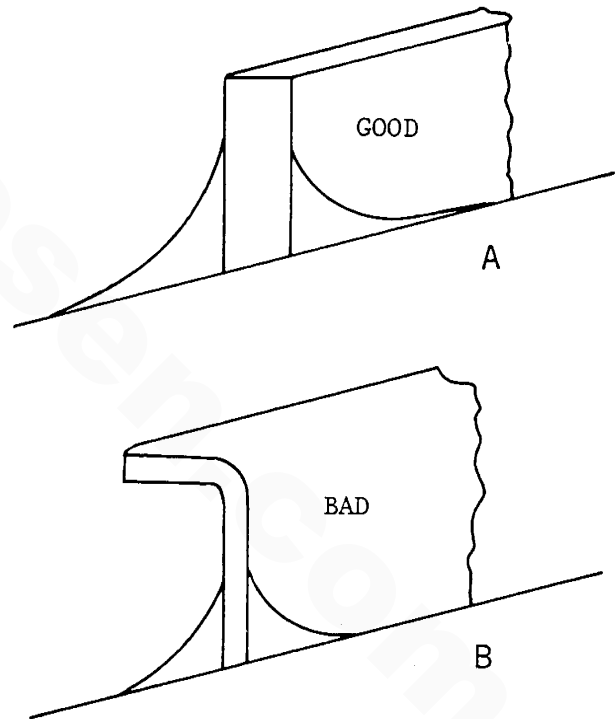

#### PROPELLER COUPLING

Each Westerbeke Diesel engine is regularly fitted with a suitable coupling connecting the propeller shaft to the engine.

The coupling must not only transmit the power of the engine to turn the shaft, but must also transmit the thrust either ahead or astern from the shaft to the thrust bearing which is built into the reduction gear housing of the engine. This coupling is very carefully machined for accurate fit.

For all engine models, a propeller half-coupling, bored to shaft size for the specific order, is supplied. The coupling either has a keyway with set screws or is of the clamping type.

The forward end of the propeller shaft has a long straight keyway. Any burrs should be removed from the shaft end. The coupling should be a light drive fit on the shaft and the shaft should not have to be scraped down or filed in order to get a fit. It is important that the key be properly fitted both to the shaft and the coupling. The key should fit the side of the keyway very closely, but should not touch the top of the keyway in the hub of the coupling.

If it seems difficult to drive the coupling over the shaft, the coupling can be expanded by heating in a pail of boiling water. The face of the propeller coupling must be exactly perpendicular to the centerline or axis of the propeller shaft.

#### PROPELLER

The type and size of propeller varies with the gear ratio and must be selected to fit the application based upon boat tests. To utilize the full power of the engine, and to achieve ideal loading conditions, it is desirable to use a propeller which will permit the engine to reach its full rated speed at full throttle under normal load.

#### ALIGNMENT OF ENGINE

The engine must be properly and exactly aligned with the propeller shaft. No matter what material is used to build a boat it will be found to be flexible to some extent and the boat hull will change its shape to a greater extent than is usually realized when it is launched and operated in the water. It is therefore very important to check the engine alignment at frequent intervals and to correct any errors when they may appear.

Misalignment between the engine and the propeller shaft is the cause of troubles which are blamed often on other causes. It will create excessive bearing wear, rapid shaft wear and will, in many cases, reduce the life of the hull by loosening the hull fastenings. A bent propeller shaft will have exactly the same effect and it is therefore necessary that the propeller shaft itself be perfectly straight.

One particularly annoying result of misalignment may be leakage of transmission oil through the rear oil seal. Check to make sure that alignment is within the limits prescribed.

The engine should be moved around on the bed and supported on the screw-jacks or shims until the two halves of the couplings can be brought together without using force and so that the flanges meet evenly all around. It is best not to drill the foundation for the foundation bolts until the approximate alignment has been accurately determined.

Never attempt a final alignment with the boat on land. The boat should be in the water and have had an opportunity to assume its final water form. It is best to do the alignment with the fuel and water tanks about half full and all the usual equipment on board and after the main mast has been stepped and final rigging has been



accomplished.

Take plenty of time in making this alignment and do not be satisfied with anything less than perfect results.

The alignment is correct when the shaft can be slipped backward and forward into the counterbore very easily and when a feeler gauge indicates that the flanges come exactly together at all points. The two halves of the propeller coupling should be parallel within 0.002 inches (A).

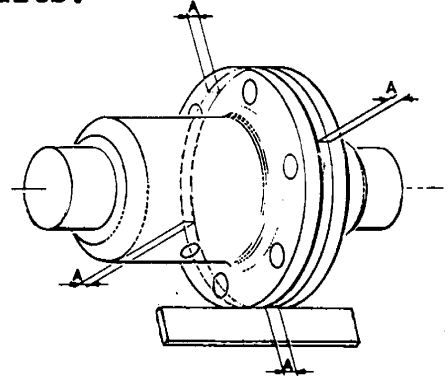

In making the final check for alignment, the engine half coupling should be held in one position and the alignment with the propeller coupling tested with the propeller coupling in each of four positions, rotated 90° between each position. This test will also check whether the propeller half coupling is in exact alignment on its shaft. Then, keeping the propeller coupling in one position, the alignment should be checked rotating the engine half coupling to full position each 90° from the next one.

The engine alignment should be rechecked after the boat has been in service for one to three weeks and, if necessary, the alignment remade. It will usually be found that the engine is no longer in alignment. This is not because the work was improperly done at first but because the boat has taken some time to take its final shape, and the engine bed and engine stringers have probably absorbed some moisture. It may even be necessary to re-align at a further period.

The coupling should always be opened up and the bolts removed whenever the boat is hauled out or moved from the land to the water, and during storage in a cradle. The flexibility of the boat often puts a very severe strain on the shaft or the coupling or both when it is being moved. In some cases the shaft has actually been bent by these strains. This does not apply to small boats that are hauled out of the water when not in use, unless they are dry for a considerable time.

#### EXHAUST SYSTEM

Exhaust line installations vary considerably and each must be designed for the particular job. The general requirements are to provide an outlet line with a minimum of restrictions and arranged so that sea water, rain water or condensation cannot get back into the engine. There should be a considerable fall in the line between the exhaust manifold flange and the discharge end. This slope in the pipe makes it difficult for water to be driven in very far by a wave, and a steep drop followed by a long slope is better than a straight gradual slope. Avoid any depression or trough to the line which would fill with water and obstruct the flow of exhaust gas. Also avoid any sharp bends.

Brass or copper is not acceptable for wet exhaust systems, as the combination of salt water and diesel exhaust gas will cause rapid deterioration. Galvanized iron fittings and galvanized iron pipe are recommended for the exhaust line. The exhaust line must be at least as large as the engine exhaust manifold flange and be increased in size if there is an especially long run and/or many elbows. It should be increased by 1/2" in I.D. for every 10 feet beyond the first

10 feet.

Most exhaust systems today use a water lift type muffler such as the Westerbeke "Hydro-Hush". In most installations there is a dry, insulated high loop after the engine manifold and before the muffler to prevent water flowing backwards into the engine during cranking.

It is essential not to hang too much weight in the form of exhaust system components rigidly from the engine manifold. Generally, it is permissible to directly connect a pipe nipple and a water jacketed exhaust elbow, which two components weigh about 8 pounds (4 kg). If there are more components to be rigidly connected to each other than will weigh 8 pounds, then a flexible exhaust section must be installed between the manifold outlet and the exhaust system.

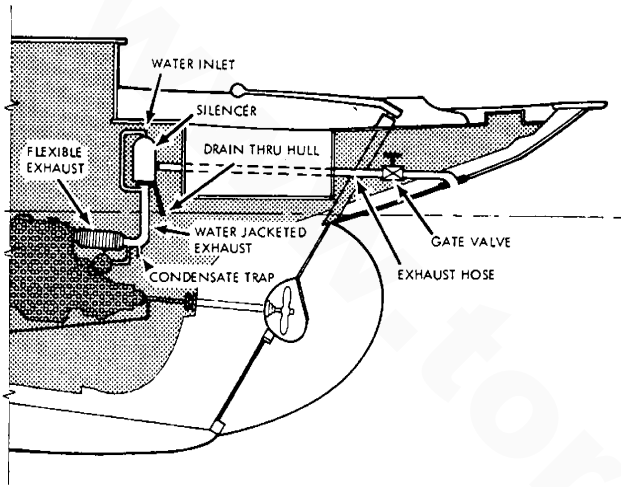

EXHAUST SYSTEM WITH WATER JACKETED STANDPIPE

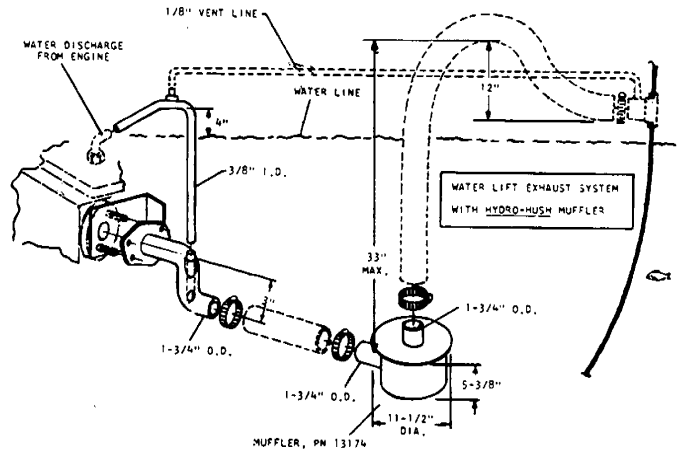

WATER LIFT EXHAUST SYSTEM WITH "HYDRO-HUSH MUFFLER"

The exhaust system must be supported or suspended independently of the engine manifold, usually using simple metal hangers secured to the overhead.

All dry portions of the exhaust system should be wrapped in suitable insulation material to keep surface temperatures as low as possible.

Many installations use flexible rubber exhaust hose for the water cooled section of the exhaust line because of the ease of installation and flexibility. Provide adequate support for the rubber hose to prevent sagging, bending and formation of water pockets.

Always arrange the rubber hose section so that water cannot possibly flow back into the engine. Also make sure that entering sea water cannot spray directly against the inside of the exhaust piping. Otherwise, excessive erosion will occur.

#### MEASURING EXHAUST GAS BACK PRESSURE

Back pressure must be measured on a straight section of the exhaust line and as near as possible to the engine exhaust manifold. The engine should be run at maximum load during the measurement period. Set-up should be as shown below.

1. For normally asperated engines:

<u>Pressure Test</u>	<u>Mercury Test</u>	<u>Water Column</u>
1-1/2" Max PSI	3" Mercury	= 39"

2. For turbo-charged engines:

<u>Pressure Test</u>	<u>Mercury Test</u>	<u>Water Column</u>
0.75 Max PSI	1-1/2" Mercury	= 19-1/2"

#### Checking The Back Pressure

1. Exhaust pipe flange
  2. Exhaust line
  3. Transparent plastic hose, partly filled with water.
- Measurement "A" may not exceed 39" for normally asperated engines and 19.5" for turbo-charged engines.

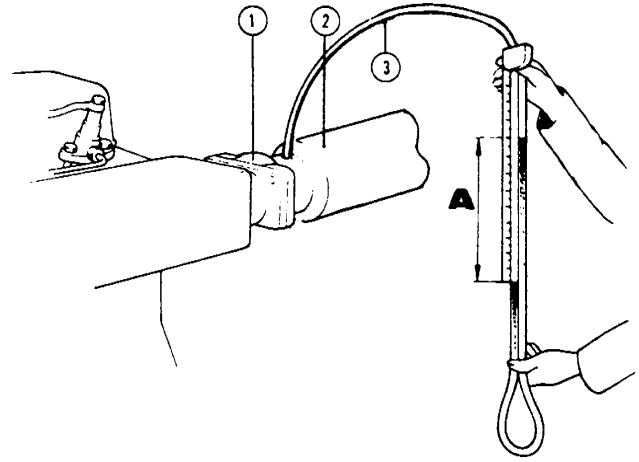

#### WATER CONNECTIONS

Seacocks and strainers should be of the full flow type at least one size greater than the inlet thread of the sea water pump. The strainer should be of the type which may be withdrawn for cleaning while the vessel is at sea.

Water lines can be copper tubing or wire-wound, reinforced rubber hose. In any case, use a section of flexible hose that will not collapse under suction, between the hull inlet and engine and between the outlet and the exhaust system. This takes up vibration and permits the engine to be moved slightly when it is being re-aligned. Do not use street elbows in suction piping. All pipe and fittings should be of bronze. Use sealing compound at all connections to prevent air leaks. The neoprene impeller in the sea (raw) water pump should never be run dry.

#### FUEL TANK AND FILTERS

Fuel tanks may be of fiberglas, monel, aluminum, plain steel or terne plate. If made of fiberglas, be certain that the interior is gel coated to prevent fibers from contaminating the fuel system. Copper or galvanized fuel tanks should not be used. It is not necessary to mount the tank above the engine level as the fuel lift pump provided will raise the fuel from the tank. The amount of lift should be kept minimum (6 feet being maximum). If a tank is already installed above the engine level, it can be utilized in this position. Great care should be taken to ensure that the fuel system is correctly installed so that airlocks are eliminated and precautions taken against dirt and water entering the fuel.

A primary fuel filter of the water collecting type should be installed between the fuel tank and the fuel lift pump. A recommended type is available from the list of accessories. The secondary fuel filter is fitted on the engine between the fuel lift pump and the injection pump and has a replaceable element.

As the fuel lift pump has a capacity in excess of that required by the injection pump, the overflow is piped to the fuel tank and should be connected to the top of the tank or as near the top as possible.

To insure satisfactory operation, a diesel engine must have a dependable supply of clean diesel fuel. For this reason, cleanliness and care are especially important at the time when the fuel tank is installed, because dirt left anywhere in the fuel lines or tank will certainly cause fouling of the injector nozzles when the engine is started for the first time.

#### FUEL PIPING

We recommend copper tubing together with suitable fittings, both

for the supply line and the return line. Run the tubing in the longest pieces obtainable to avoid the use of unnecessary fittings and connectors. The shut off valve in the line between the fuel tank and engine should be of the fuel oil type, and it is important that all joints be free of pressure leaks.

Keep fuel lines as far as possible from exhaust pipe for minimum temperature, to eliminate "vapor locks".

The fuel piping leading from the tank to the engine compartment should always be securely anchored to prevent chafing. Usually the copper tubing is secured by means of copper straps.

The final connection to the engine should be through flexible rubber hoses.

#### ELECTRIC PANEL

The Westerbeke all-electric panel utilizes an electronic tachometer with a built-in hourmeter. Tachometer cables are no longer required, except for the Skipper mechanical panel. Mounted on the panel are a voltmeter, water temperature gauge and oil pressure gauge. Each instrument is lighted. The all-electric panel is isolated from ground and may be mounted where visible. It is normally pre-wired.

#### ELECTRICAL EQUIPMENT

Most Westebeke engines are supplied pre-wired and with plug-in connectors. Never make or break connections while the engine is running. Carefully follow all instructions on the wiring diagram supplied, especially those relating to fuse/circuit breaker requirements.

Starter batteries should be located as close to the engine as possible to avoid voltage drop through long leads. It is bad practice to use the starter batteries for other services unless they require low amperage or are intermittent. In cases where there are substantial loads (from lights, refrigerators, radios, depth sounders, etc.), it is essential to have a complete, separate system and to provide charging current for this by means of a second alternator or "alternator output splitter".

Starter batteries must be of a type which permits a high rate of discharge (Diesel starting).

Carefully follow the recommended wire sizes shown in the wiring diagrams. Plan installation so the battery is close to the engine and use the following cable sizes:

- #1 - for distances up to 8 feet
- #1/0 - for distances up to 10 feet
- #2/0 - for distances up to 13 feet
- #3/0 - for distances up to 16 feet

#### MECHANICAL CONTROLS

The recommended practice is to have the stop-run lever loaded to the run position and controlled by a sheathed cable to a push-pull knob at the pilot station. The throttle lever should be connected to a Morse type lever at the pilot station by a sheathed cable.

The transmission control lever may be connected to the pilot station by a flexible, sheathed cable and controlled by a Morse type lever. The single-lever type gives clutch and throttle control with full throttle range in neutral position. The two-lever type provides clutch control with one lever and throttle control with the other.

Any bends in the control cables should be gradual. End sections

at engine and transmission must be securely mounted. After linkages are completed, check the installation for full travel, making sure that, when the transmission control lever at the pilot station is in forward, neutral and reverse, the control lever on the transmission is on the respective detent. Check the throttle control lever and the stop-run lever on the fuel injection pump for full travel.

Some models do not require a stop cable because they have either a fuel solenoid or an electric fuel pump. Examples of such models are the W58 and the W52.

[www.torresen.com](http://www.torresen.com)

# OPERATION

## PREPARATION FOR FIRST START

The engine is shipped "dry"...with lubricating oil drained from the crankcase and fluid from the transmission. Therefore, be sure to follow these recommended procedures carefully before starting the engine for the first time.

1. Remove oil filler cap and fill oil sump with heavy duty, diesel lubricating oil to the highest mark on the dipstick. See table under Maintenance for an approved lubricating oil. Do not overfill. Select an approved grade from the listing and continue to use it.

2. Fill the reverse gear to the highest mark on the dipstick with TYPE A transmission fluid. Do not overfill. Refer to the Transmission Section of this manual for details.

Engine oil is not recommended because it can foam, and it can contain additives harmful to some transmissions.

If the engine is equipped with a V-drive, fill to the full mark on the dipstick with the recommended lubricant specified on the data tag on the V-drive housing.

3. Fill fresh water cooling system with a 50-50 antifreeze solution only after opening all petcocks and plugs until all entrapped air is expelled.

Fill surge tank to within one inch of the top. Check this level after engine has run for a few minutes. If trapped air is released, the water level may have dropped. If so, refill tank to within one inch of top and replace filler cap.

4. Ensure battery water level is at least 3/8" above the battery plates and battery is fully charged so that it is capable of the extra effort that may be required on the first start.

5. Fill fuel tank with clean diesel fuel oil; No. 2 diesel fuel oil is recommended. The use of No. 1 is permissible but No. 2 is preferred because of its higher lubricant content.

NOTE: If there is no filter in the filler of the fuel tank, the recommended procedure is to pour the fuel through a funnel of 200 mesh wire screen.

6. Fill grease cup on the sea water pump, if present, with a good grade of water pump grease.

## FUEL SYSTEM

The fuel injection system of a compression ignition engine depends upon very high fuel pressure during the injection stroke to function correctly. Relatively tiny movements of the pumping plungers produce this pressure and, if any air is present inside the high pressure line, then this air acts as a cushion and prevents the correct pressure, and therefore fuel injection, from being achieved.

In consequence, it is essential that all air is bled from the system whenever any part of the system has been opened for repair or servicing.

BLEEDING PROCEDURES BY MODEL

1. Initial Engine Start-up (Engine stoppage due to lack of fuel)
  - a. Insure that the fuel tank(s) is filled with the proper grade of diesel fuel.
  - b. Fill any large primary filter/water separator with clean diesel fuel that is installed between the fuel tank and engine. To attempt to fill any large primary filter using the manual priming lever on the engine mounted fuel lift pump may prove futile or require a considerable amount of priming.
  - c. Turn the fuel selector valve to "On". Systems with more than one tank insure that fuel returning is going to the tanks being used.

The above procedures are basic for all initial engine start-ups or for restarting engines stopping due to lack of fuel.

WESTERBEKE W7 AND WPD4 GENERATOR (3600 RPM) (Figure 1)

1. With the use of a 5/16 box wrench or common screw driver, open the bleed screw one or two turns on the outgoing side of the engine mounted secondary fuel filter (Bleed point A). With firm strokes on the lift pump priming lever, bleed until fuel free of air bubbles flows from this point. Stop priming and gently tighten the bleed screw.
2. With a 5/8 open end wrench loosen one to two turns the nut securing the injector line to the injector (Bleed point B).

Decompress the engine with the lever on the top of the cylinder head. Crank the engine over with the starter. (W7: ensure that the engine stop lever is in the run position and the throttle is full open.) (4KW: use the defeat position while cranking.) Crank the engine until fuel spurts by the nut and line. Stop cranking and tighten the 5/8 nut and proceed with normal starting procedures.

WESTERBEKE W30 (Figure 2), W40 & WPO10, 12½, 15 (Figure 3), W50 & WBO 15 (Figure 4), W80 & BR 30 (Figure 5), W120 & BR 45 (Figure 5)

1. Open the banjo bolt on top of the engine mounted secondary fuel filter 1-2 turns (Bleed Point A). With firm stroke on the fuel lift pump priming lever, bleed until fuel free of air bubbles flows from this point. Stop priming and tighten the bolt.
2. On the fuel injection pump body is a 5/16 bleed screw (Bleed Point B). This may be mounted on a manifold with a pressure switch. Open this one or two turns (do not remove it) and with the priming lever bleed until fuel free of air bubbles flows. Stop priming and tighten the bleed screw.
3. On the control cover of the injection pump (Bleed Point C) is a 5/16 bleed screw. Open this screw one to two turns and proceed as in Step 2. (Note: Bypass this bleed point on the W30 injection pump.)

4. W50 injection pump only. Open the 5/16 bleed screw (Bleed Point D) on the injector line banjo bolt one or two turns and, with the throttle full open and the engine stop lever in the run position, crank the engine over with the starter until clear fuel free of air flows from this point. Stop cranking and tighten this bleed screw.
5. With a 5/8 wrench loosen one to two turns the injector line attaching nuts at the base of each injector and, with the throttle full open and the engine stop control in the run position, crank the engine over with the starter until fuel spurts by the nuts and injector line at each injector. Stop cranking and tighten the nut and proceed with normal starting procedures.

WESTERBEKE W13, 4.4KW, W21, 7.7KW, W27, 11.1KW, W33, 12.5KW (Figure 6)

These units are self-bleeding.

1. Turn the ignition to the ON position and wait 15-20 seconds.
2. Start the engine following normal starting procedures.

WESTERBEKE W58 & WTO 20 (Figure 7)

1. Open the bleed screw on the top inboard side of the engine-mounted secondary fuel filter one to two turns using a 10mm box wrench (Bleed Point A). This fuel filter is equipped with a hand-operated priming pump. With the palm of your hand, pump this primer until fuel free of air flows from this point. Stop pumping and tighten the bleed screw.
2. With bleed screw A tightened, pump the hand primer several more times. This primes the injection pump which is self-bleeding. The injection pump incorporates a feed pump which keeps the fuel system primed when the engine is running; thus, no external lift pump is required.
3. Loosen the four injector line attaching nuts at the base of each injector (Bleed Point B) one to two turns with a 16mm open end wrench. Place the throttle in the full open position and crank the engine over with the the starter until fuel spurts by the nut and injector lines. Stop cranking and tighten each of the four nuts and proceed with normal starting procedure.

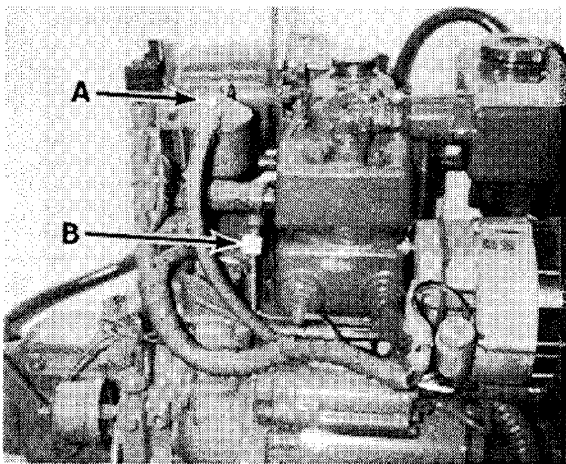

Figure 1

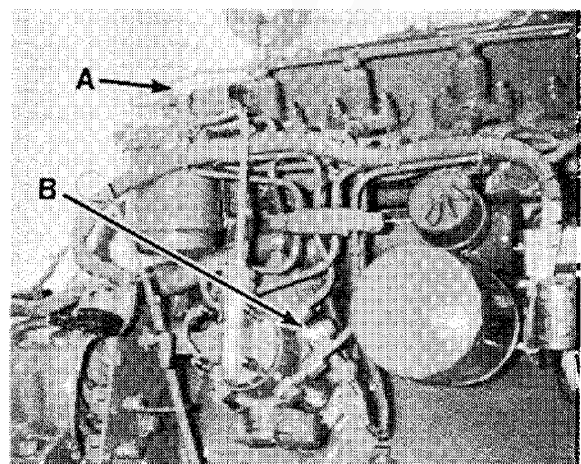

Figure 2



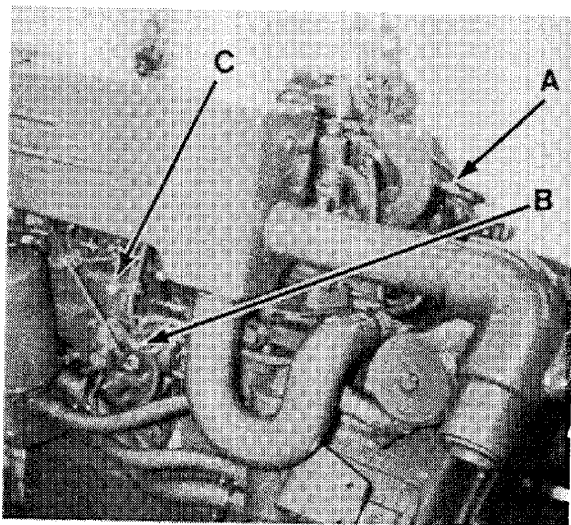

Figure 3

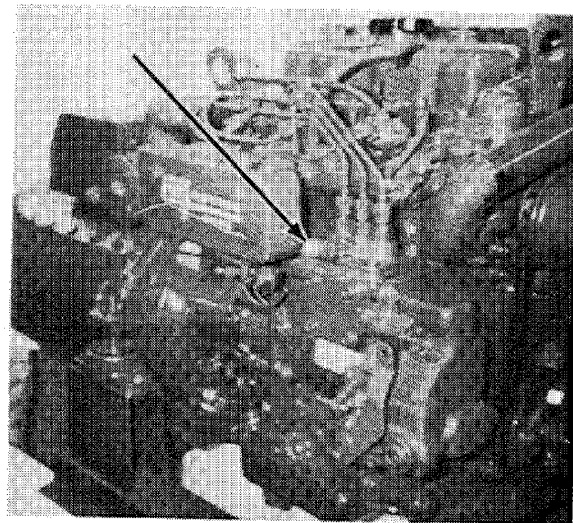

Figure 6

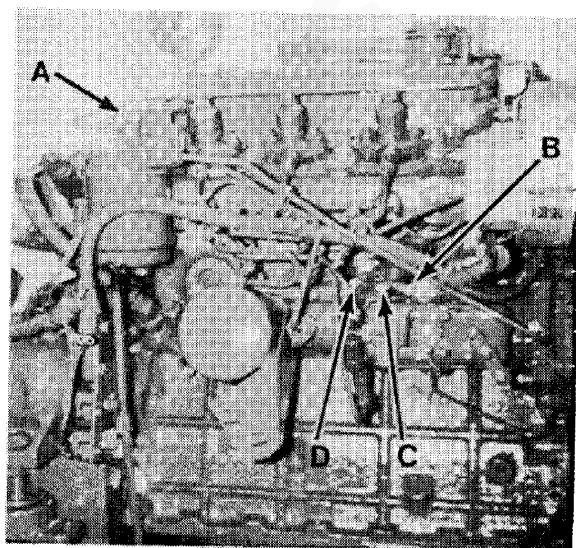

Figure 4

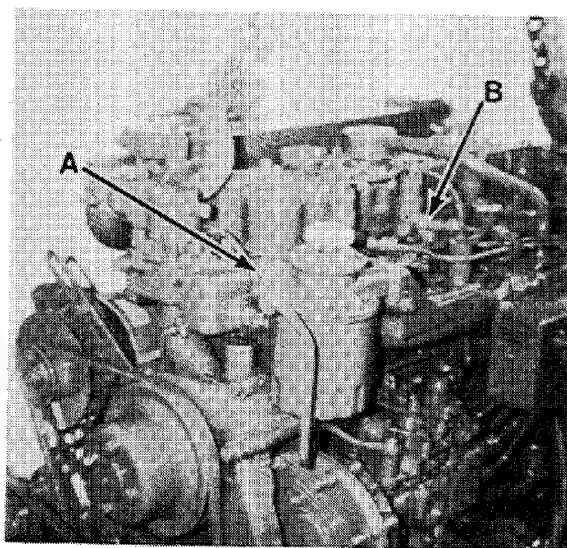

Figure 7

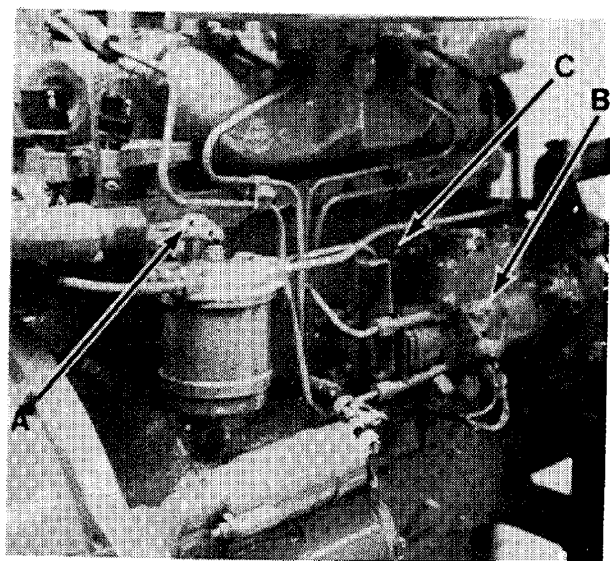
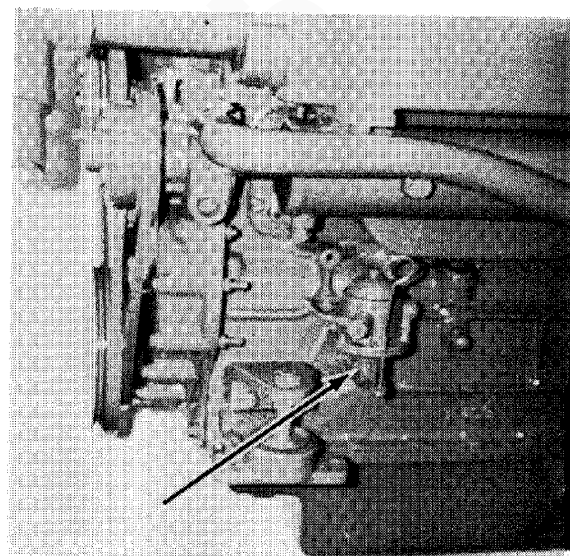

Figure 5



Typical Mechanical Fuel  
Lift Pump

### PREPARATION FOR STARTING

1. Check water level in expansion tank. It should be 1½ to 2 in. below the top of the tank when cold.
2. Check the engine sump oil level.
3. Check the transmission fluid level.
4. See that there is fuel in the tank and the fuel shut-off is open.
5. Check to see that the starting battery is fully charged, all electrical connections are properly made, all circuits in order and turn on the power at the battery disconnect.
6. Check the seacock and ensure that it is open.

### STARTING THE ENGINE (COLD)

Most Westerbeke marine diesel engines are equipped with a cold starting aid to ease in the starting of your engine when cold.

1. Check to see that the "stop" lever (if installed) is in the "run" position.
2. Place the throttle in the fully open position.
3. Press the "Preheat" button in and hold for 15 to 20 seconds.
4. While holding the "Preheat" button in, turn the keyswitch to the "ON" or "Run" position. This activates the panel gauges, lights and fuel solenoid or electric fuel pump if so equipped. Continue to turn the keyswitch to the "Start" position and hold for no more than 20 seconds. Some units may be equipped with a pushbutton to start rather than the keyswitch and in these cases the electrical system is activated by fuel pressure.
5. If the engine fails to start in 20 seconds, release start switch and preheat for an additional 15 to 20 seconds, then repeat step 4.
6. As soon as the engine starts, release the start switch and the preheat button and return the throttle to the "idle" position immediately.

**CAUTION:** Do not crank the engine more than 20 seconds when trying to start. Allow a rest period of at least twice the cranking period between the start cycles. Starter damage may occur by overworking the starter motor and the backfilling of the exhaust system is possible.

### STARTING THE ENGINE (WARM)

If the engine is warm and has only been stopped for a short time, place the throttle in the partially open position and engage the starter as above, eliminating the preheat step.

NOTE: Always be sure that the starter pinion has stopped revolving before again re-engaging the starter; otherwise, the flywheel ring gear or starter pinion may be damaged.

Ensure that the electrical connection to the cold starting aid is correct.

Extended use of the cold starting aid beyond the time periods stated should be avoided to prevent damage to the aid.

NEVER under any circumstances use or allow anyone to use ether to start your engine. If your engine will not start, then have a qualified Westerbeke marine mechanic check your engine.

#### WHEN ENGINE STARTS

1. Check for normal oil pressure immediately upon engine starting. Do not continue to run engine if oil pressure is not present within 15 seconds of starting the engine.
2. Check Sea Water Flow. Look for water at exhaust outlet. Do this without delay.
3. Recheck Crankcase Oil. After the engine has run 3 or 4 minutes, subsequent to an oil change or new installation, stop the engine and check the crankcase oil level. This is important as it may be necessary to add oil to compensate for the oil that is required to fill the engine's internal oil passages and oil filter. Add oil as necessary. Check oil level each day of operation.
4. Recheck Transmission Fluid level. (This applies only subsequent to a fluid change or new installation.) In such a case, stop the engine after running for several minutes at 800 RPM with one shift into forward and one into reverse, then add fluid as necessary. Check fluid level each day of operation.
5. Recheck Expansion Tank Water Level, if engine is fresh water cooled. (This applies after cooling system has been drained or filled for the first time.) Stop engine after it has reached operating temperature of 175°F and add water to within one inch of top of tank.

WARNING: The system is pressurized when overheated, and the pressure must be released gradually if the filler cap is to be removed. It is advisable to protect the hands against escaping steam and turn the cap slowly counter-clockwise until the resistance of the safety stops is felt. Leave the cap in this position until all pressure is released. Press the cap downward against the spring to clear the safety stops and continue turning until it can be lifted off.

6. Warm-up Instructions. As soon as possible, get the boat underway, but at reduced speed, until water temperature gauge indicates 130-150°F. If necessary, engine can be warmed up with the transmission in neutral at 1000 RPM. Warming up with the transmission in neutral takes longer and tends to overheat the transmission.

7. Reverse Operation. Always reduce engine to idle speed when shifting gears. However, when the transmission is engaged, it will carry full engine load.

NOTE: The SA0 transmission requires that when backing down, the shift lever must be held in the reverse position, since it has no positive overcenter locking mechanism.

#### STOPPING THE ENGINE

1. Position shift lever in neutral.
2. Idle the engine for 2 to 4 minutes to avoid boiling and to dissipate some of the heat.
3. If equipped with a stop lever, pull the knob and hold in this position until the engine stops. This stops the flow of fuel at the injection pump. After the engine stops, return the control to the run position to avoid difficulty when restarting the engine.
4. Turn off the keyswitch. Some models do not use the stop lever as they are equipped with a fuel solenoid or electric fuel pump which shuts off the fuel supply when the keyswitch is turned to the OFF position.
5. Close the seacock.
6. Disconnect power to system with battery switch.

#### OPERATING PRECAUTIONS

1. Never run engine for extended periods when excessive overheating occurs, as extensive internal damage can be caused.
2. DO NOT put cold water in an overheated engine. It can crack the cylinder head, block or manifold.
3. Keep intake silencer free from lint, etc.
4. Do not run engine at high RPM without clutch engaged.
5. Never Race a Cold Engine as internal damage can occur due to inadequate oil circulation.
6. Keep the engine and accessories clean.
7. Keep the fuel clean. Handle it with extreme care because water and dirt in fuel cause more trouble, and service life of the injection system is reduced.
8. Do not allow fuel to run low, because fuel intake may be uncovered long enough to allow air to enter the injection system, resulting in engine stoppage requiring system bleeding.

9. Do not be alarmed if temperature gauges show a high reading following a sudden stop after engine has been operating at full load. This is caused by the release of residual heat from the heavy metal masses near the combustion chamber. Prevention for this is to run engine at idle for a short period before stopping it. High temperature reading after a stop does not necessarily signal alarm against restarting. If there is no functional difficulty, temperatures will quickly return to normal when engine is operating.

[www.torresen.com](http://www.torresen.com)

## TEN MUST RULES

IMPORTANT

IMPORTANT

IMPORTANT

...for your safety and your engine's dependability.

### ALWAYS -

1. Keep this Manual handy and read it whenever in doubt.
2. Use only filtered fuel oil and check lube oil level daily.
3. Check cooling water temperature frequently to make sure it is 190° or less.
4. Close all drain cocks and refill with water before starting out.
5. Investigate any oil leaks immediately.

### NEVER -

6. Race the engine in neutral.
7. Run the engine unless the gauge shows proper oil pressure.
8. Break the fuel pump seals.
9. Use cotton waste or fluffy cloth for cleaning or store fuel in a galvanized container.
10. Subject the engine to prolonged overloading or continue to run it if black smoke comes from the exhaust.

## MAINTENANCE

### PERIODIC ATTENTION:

After you have taken delivery of your engine, it is important that you make the following checks right after the first fifty hours of its operation.

Note: Transmissions generally require fluid change after the first 25 to 30 hours of operation. Refer to the Transmission Section of this manual for details.

### FIFTY HOUR CHECKOUT (INITIAL)

Do the following:

1. Retorque the cylinder head bolts.
2. Retorque the rocker bracket nuts and adjust valve rocker clearance.
3. Check and adjust, if necessary, the forward drum assembly and the reverse band on manual SA0 and SA-1 transmissions.
4. Change engine lubricating oil and oil filter.
5. Check for fuel and lubricating oil leaks. Correct if necessary.
6. Check cooling system for leaks and inspect water level.
7. Check for loose fittings, clamps, connections, nuts, bolts, vee belt tensions, etc. Pay particular attention to loose engine mounts engine mount fittings. These could cause misalignment.

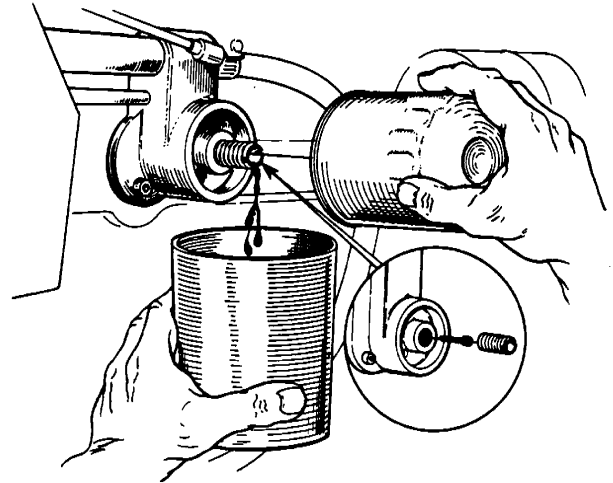

### DAILY CHECKOUT

Do the following:

1. Check the sea water strainer, if one has been installed.
2. Check water level in cooling system.
3. Check lubricating oil level in sump. Fill to highest mark on dipstick.
4. Turn down grease cup on water pump, if used, one full turn.
5. Check fluid level in transmission. Fill to highest mark on dipstick with proper fluid.

### SEASONAL CHECK-OUT (MORE OFTEN IF POSSIBLE)

Do the following:

1. Check generator, alternator and sea water pump "V" belts for proper tension.
2. Check water level in battery.
3. Change oil in sump. See Note.
4. Replace lubricating oil filter, Figure 2. See Note.
5. Fill sump with diesel lubricating oil to highest mark on dipstick. Refer to Specification page for proper quantity of oil. Do Not Overfill. See Note.

CAUTION: The use of different brands of lubricating oils during oil changes has been known to cause extensive oil sludging and may in many instances cause complete oil starvation.

6. Start engine and run for 3 or 4 minutes. Stop engine and check oil filter gasket for leaks. Check oil sump level. This is important as it may be necessary to add oil to compensate for the oil that is required to fill the engine's internal oil passages and oil filter. Add oil as necessary. See Note.

#### IMPORTANT NOTE

IT IS MANDATORY THAT THE CHECKS 3, 4, 5 AND 6 BE ATTENDED TO WHEN TOTAL OPERATING TIME REACHES 150 HOURS. IN SOME INSTANCES, THIS TOTAL IS REACHED BEFORE END OF SEASON.

7. Clean Air Filter if supplied. (Most models have an air silencer that does not require cleaning.) The time period for replacing the air filter depends on operating conditions; therefore, under extremely dirty conditions, the seasonal frequency should be increased. The correct time periods for replacing the filter will greatly assist in reducing bore wear, thereby extending the life of the engine.

8. Check engine for loose bolts, nuts, etc.

9. Check sea water pump for leaks.

10. Wash primary filter bowl and screen. If filter bowl contains water or sediment, filter bowl and secondary oil fuel filter need be cleaned more frequently.

11. Replace secondary fuel filter element.

12. Replace air filter.

13. Change the fluid in the transmission. Refer to the Transmission Section of this manual for details.

#### END OF SEASON SERVICE

1. Drain fresh water cooling system by removing the surge tank pressure cap and opening all water system petcocks.

2. Remove zinc rod (usually located in heat exchanger) and see if it needs replacing. The zinc rod will take care of any electrolysis that may occur between dissimilar metals. Insert new zinc if necessary.

3. Fill fresh water cooling system with antifreeze of a reputable make. (Refer to Cold Weather Precautions.)

4. Start engine. When temperature gauge indicates 175°F, shut engine down and drain lubricating oil. Remove and replace filter. Fill sump with High Detergent Lubricating Oil.

5. Carefully seal air intake opening with waterproofed adhesive tape or some other suitable medium.

6. Seal the exhaust outlet at the most accessible location as close to the engine as possible.

7. Remove injectors and spray oil into cylinders.

8. Replace injectors with new sealing washer under each injector. Turn engine slowly over compression.

9. Top off fuel tank completely so that no air space remains, thereby preventing water formation by condensation.

10. Leave fuel system full of fuel.

11. Change fuel filters before putting the engine back in service.

12. Wipe engine with a coat of oil or grease.

13. Change fluid in transmission. Refer to the Transmission Section of this manual for details.

14. Disconnect battery and store in fully charged condition. Before



storing the battery, the battery terminals and cable connectors should be treated to prevent corrosion. Recharge battery every 30 days.

15. Check alignment.

[www.torresen.com](http://www.torresen.com)

LUBRICATING OILS

Lubricating oils are available for Westerbeke Diesel engines which offer an improved standard of performance to meet the requirements of modern operating conditions such as sustained high speeds and temperatures.

These oils meet the requirements of the U. S. Ordnance Specifications MIL-L-2104B (API Service CC). Any other oils which also conform to these specifications, but are not listed here, are, of course, also suitable.

COMPANY	BRAND	S.A.E. DESIGNATION		
		0°/45°F	45°/80°F	OVER 80°F
American Oil Co.	American Supermil Motor Oil	10W	20W/20	30
BP Canada Ltd.	BP Vanellus	10W	20W/20	30
	BP Vanellus	10W/30	10W/30	10W/30
Chevron Oil Co.	RPM DELO Multi service Oil	10W	20W/20	30
Cities Service Oil Co.	CITGO Extra Range	10W	20W/20	30
Continental Oil Co.	CONOCO TRACON OIL	10W	20W/20	30
Gulf Oil Corporation	Gulflube Motor Oil X.H.D.	10W	20W/20	30
Mobil Oil Company	Delvac 1200 Series	1210	1220	1230
Shell Oil Company	Shell Rotella T Oil	10W	20W/20	30
Sun Oil Company	Subfleet MIL-B	10W	20W/20	30
Texaco, Inc.	Ursa Oil Extra Duty	10W	20W/20	30

## YOUR NOTES

[www.torresen.com](http://www.torresen.com)

## ENGINE OVERHAUL

The following sections contain detailed information relating to the proper operating characteristics of the major components and systems in the engine. Included are disassembly, rework and reassembly instructions for the guidance of suitably equipped and staffed marine engine service and rebuilding facilities. The necessary procedures should be undertaken only by such facilities.

Additional operating characteristics are included in the Operation Section of this manual.

Any replacements should be made only with genuine Westerbeke parts.

**GENERAL SPECIFICATION DATA**

**ENGINE – Diesel 1.8 litre**

Type .....	18V – – – D
Number of cylinders .....	4
Bore .....	3.16 in (80.26 mm)
Stroke .....	3.5 in (88.9 mm)
Capacity .....	109.8 in <sup>3</sup> (1799 cm <sup>3</sup> )
Injection order .....	1, 3, 4, 2
Valve operation .....	Overhead by push-rod
Compression ratio .....	21.47 : 1
Torque (gross) .....	79 lbf ft (10.92 kgf m) at 2,400 rev/min

**Crankshaft**

Main journal diameter .....	2.1262 to 2.1270 in (53.992 to 54.012 mm)
Minimum regrind diameter .....	2.1162 to 2.1170 in (52.742 to 53.762 mm)
Crankpin journal diameter .....	1.8759 to 1.8764 in (47.64 to 47.65 mm)
Minimum regrind diameter .....	1.8659 to 1.8664 in (47.39 to 47.40 mm)
Crankshaft end-thrust .....	Taken on thrust washers at centre main bearing
Crankshaft end-float .....	0.001 to 0.0055 in (0.025 to 0.139 mm)

**Main bearings**

Number and type .....	5 Steel backed lead indium
Length: Front, centre and rear .....	1.120 to 1.130 in (28.45 to 28.70 mm)
Intermediate .....	0.760 to 0.770 in (19.30 to 19.55 mm)
Diametrical clearance .....	0.001 to 0.0027 in (0.03 to 0.07 mm)
Undersizes .....	0.010 in (0.25 mm)

**Connecting rods**

Type .....	Horizontally split big-end, plain small end
Length between centres .....	6.220 to 6.222 in (157.9 to 158.0 mm)

**Big-end bearings**

Type .....	Steel backed lead indium
Length .....	0.775 to 0.785 in (19.68 to 19.93 mm)
Diametrical clearance .....	0.001 to 0.0027 in (0.03 to 0.07 mm)
Undersizes .....	0.010 in (0.25 mm)

**Gudgeon pin**

Type .....	Fully floating with circlip location
Fit in piston .....	0.0001 to 0.0003 in (0.002 to 0.007 mm) clearance
Fit in connecting rod .....	0.0002 to 0.0009 in (0.02 to 0.04 mm) clearance
Diameter (outer) .....	0.9998 to 1.0000 in (25.39 to 25.40 mm)

**Pistons**

Type .....	Aluminium alloy, solid skirt, with open combustion cavity
Clearances:	
Top land .....	0.0171 to 0.0211 in (0.43 to 0.57 mm)
Bottom land .....	0.0137 to 0.0172 in (0.35 to 0.44 mm)
Bottom of skirt .....	0.004 to 0.005 in (0.10 to 0.13 mm)
Oversizes .....	0.020 in and 0.040 in (0.51 mm and 1.02 mm)

**Piston rings**

Compression:	
Type: Top .....	Chrome-faced
Second .....	Tapered, cast iron alloy
Width .....	0.0771 to 0.0781 in (1.96 to 1.98 mm)
Fitted gap: Top .....	0.012 to 0.017 in (0.30 to 0.43 mm)
Second .....	0.009 to 0.014 in (0.23 to 0.35 mm)
Ring to groove clearance: Top .....	0.0025 to 0.0045 in (0.06 to 0.11 mm)
Second .....	0.0015 to 0.0035 in (0.04 to 0.09 mm)
Oil control	
Type .....	Slotted scraper
Fitted gap .....	0.012 to 0.017 in (0.30 to 0.43 mm)
Ring to groove clearance .....	0.0015 to 0.0035 in (0.04 to 0.09 mm)

<b>Camshaft</b>	
Journal diameters: Front .....	1.78875 to 1.78925 in (45.43 to 45.44 mm)
Centre .....	1.72875 to 1.72925 in (43.91 to 43.93 mm)
Rear .....	1.62275 to 1.62325 in (41.22 to 41.23 mm)
Bearing liner inside diameter (reamed after fitting):	
Front .....	1.79025 to 1.79075 in (45.47 to 45.48 mm)
Centre .....	1.73025 to 1.73075 in (43.95 to 43.96 mm)
Rear .....	1.62425 to 1.62475 in (40.26 to 40.27 mm)
Diametrical clearance .....	0.001 to 0.002 in (0.02 to 0.05 mm)
End-thrust .....	Taken on locating plate
End-float .....	0.003 to 0.007 in (0.08 to 0.18 mm)
<b>Rocker gear</b>	
Rocker shaft diameter .....	0.624 to 0.625 in (15.85 to 15.87 mm)
Rocker bush inside diameter (reamed in position) .....	0.6255 to 0.6260 in (15.89 to 15.90 mm)
<b>Tappets</b>	
Type .....	Bucket
Outside diameter .....	0.8125 in (20.65 mm)
Length .....	1.495 to 1.505 in (37.97 to 38.23 mm)
<b>Valves</b>	
Seat angle: Inlet .....	45°
Exhaust .....	45°
Head diameter: Inlet .....	1.434 to 1.439 in (36.42 to 36.55 mm)
Exhaust .....	1.207 to 1.212 in (30.64 to 30.78 mm)
Stem diameter: Inlet .....	0.3428 to 0.3433 in (8.71 to 8.73 mm)
Exhaust .....	0.3422 to 0.3427 in (8.69 to 8.70 mm)
Stem to guide clearance: Inlet .....	0.0008 to 0.0020 in (0.02 to 0.05 mm)
Exhaust .....	0.0014 to 0.0026 in (0.03 to 0.06 mm)
Valve lift: Inlet and exhaust .....	0.384 in (9.75 mm)
Valve: Stand down .....	0.0445 to 0.0505 in (1.13 to 1.28 mm)
<b>Valve guides</b>	
Length: Inlet and exhaust .....	2.22 in (56.39 mm)
Outside diameter: Inlet and exhaust .....	0.5635 to 0.5640 in (14.31 to 14.33 mm)
Inside diameter (reamed after fitting): Inlet and exhaust .....	0.3441 to 0.3448 in (8.74 to 8.76 mm)
Fitted height above spring seat: Inlet and exhaust .....	0.55 to 0.56 in (13.9 to 14.2 mm)
Interference fit in head: Inlet and exhaust .....	0.0005 to 0.00175 in (0.01 to 0.04 mm)
<b>Valve springs</b>	
Free length .....	1.92 in (48.77 mm)
Fitted length .....	1.44 in (36.57 mm)
Load at fitted length .....	82 lbf (37.19 kgf, 364 N)
Load at top of lift .....	142 lbf (64.4 kgf, 631 N)
Number of working coils .....	4½
<b>Valve timing</b>	
Timing marks .....	Dimples on timing wheels, marks on flywheel
Rocker clearance: Running .....	0.017 in (0.43 mm) cold
Timing .....	0.024 in (0.61 mm)
Inlet valve: Opens .....	8° B.T.D.C.
Closes .....	42° A.B.D.C.
Exhaust valve: Opens .....	60° B.B.D.C.
Closes .....	12° A.T.D.C.
<b>Lubrication</b>	
System .....	Wet sump, pressure fed
System pressure: Running .....	Between idle and running speed the pressure will vary from 45-85 psi.
Oil pump .....	Rotor type
Oil filter .....	Full flow; disposable cartridge type
Oil pressure relief valve .....	50 lbf/in <sup>2</sup> (3.52 kgf/cm <sup>2</sup> )
Relief valve springs: Free length .....	3 in (76 mm)
Fitted length .....	2.156 in (54.77 mm)
Load at fitted length .....	15.5 to 16.5 lbf (7.0 to 7.4 kgf, 69 to 73 N)

**FUEL SYSTEM**

Fuel injection pump .....	C.A.V
Type .....	DPA
Injection timing .....	18° B.T.D.C.
Fuel lift pump .....	A.C. Mechanical
Fuel injectors .....	C.A.V. Pintaux
Nozzle type .....	BDN.OSPC.6651
Nozzle holder type .....	BKB.35SD.5188
Opening pressure .....	135 Atm
Main fuel filter .....	C.A.V.
Type .....	FS583 6B130
Heater plugs .....	
Champion .....	AG32

**TORQUE WRENCH SETTINGS**

	lbf ft	kgf m	Nm
Cylinder head nuts .....	75	10.4	102
Rocker bracket nuts .....	25	3.5	34
Manifold nuts .....	15	2.1	20
Big-end nuts .....	35	4.8	47
Main bearing set screws .....	75	10.4	102
Flywheel bolts .....	40	5.5	54
Timing cover bolts: ¼ in .....	14	1.9	19
⅝ in .....	30	4.1	41
Rear plate bolts: ⅝ in .....	20	2.8	27
⅝ in .....	30	4.1	41
Camshaft nut .....	65	9.0	88
Crankshaft bolt .....	75	10.4	101
Idler gear hub bolt .....	30	4.1	41
Cylinder side cover set screws .....	4	0.5	5
Rocker cover nuts .....	4	0.5	5
Sump bolts .....	6	0.8	8
Oil filter adaptor .....	30	4.1	41
Oil pump nuts .....	16	2.2	22
Oil release valve – domed nut .....	45	6.2	61
Starter motor bolts .....	35	4.8	47
Clutch to flywheel .....	25	3.5	34
Fuel lift pump nuts .....	12	1.7	16
Injector nozzle nut .....	50	6.9	68
Injection pump nuts .....	18	2.5	24
Injector nuts .....	12	1.7	16
Injection pump driving flange set screws ..	10	1.4	14
Water pump bolts .....	17	2.3	23
Water pump pulley set screws .....	18	2.5	24
Alternator pulley nut .....	27	3.7	36
Thermal transmitter .....	16	2.2	22

**TRANSMISSIONS**

- Type SAO Westerbeke/Paragon Manual
- Type SAOV with RV10S Vee Drive
- Short Profile Sailing Gear
- Paragon Hydraulic
- Warner Hydraulic
- Propeller rotation is left hand except Warner 1.91 to 1

**ENGINE MOUNTS**

Type..... Flexible Adjustable

**COOLING SYSTEM**

Type..... Centrifugal Pump, Thermostat  
 Thermostat Setting..... 82C (180F)  
 Water Capacity (Fresh)..... 7 Quarts

**FUEL INJECTION PUMP HUB**

Remove and refit 12.10.26  
 Fuel injection pump gear 1 to 5 and 12 to 18 12.10.25

**Removing**

- 1 Remove the timing chain, see 12.65.14.
- 2 Remove the injection pump, see 19.30.07.
- 3 Remove the four bolts from the injection pump driving flange.
- 4 Withdraw the driving flange and collect the two locating half plates.
- 5 Withdraw the injection pump gear.
- 6 Remove the injection pump drive oil feed pipe.
- 7 Remove the countersunk screw from the injection pump hub.
- 8 Remove the upper bolt from the chain vibration damper.
- 9 Remove the injection pump hub.
- 10 Remove the hub gasket.
- 11 Remove the oil pipe union from the hub.

**Refitting**

- 12 Reverse the procedure in 5 to 11.
- 13 Ensure that the circlip is correctly located in its groove in the splined bore of the injection pump driving flange.
- 14 Fit one of the locating half plates to its groove in the injection pump hub, and position it by inserting a  $\frac{3}{8}$  in (5.5 mm) peg through the timing hole in the locating plate and into the timing hole in the gear.
- 15 Fit the second locating half plate and then fit the driving flange, engaging the driving flange timing hole with the peg.
- 16 Fit and tighten the driving flange bolts to 10 lbf ft (1.4 kgf m, 14 Nm); ensure that the peg can be withdrawn from the timing hole and lock the bolts with their lockplates.
- 17 Fit the timing chain, see 12.65.14.
- 18 Fit the injection pump, see 19.30.07.

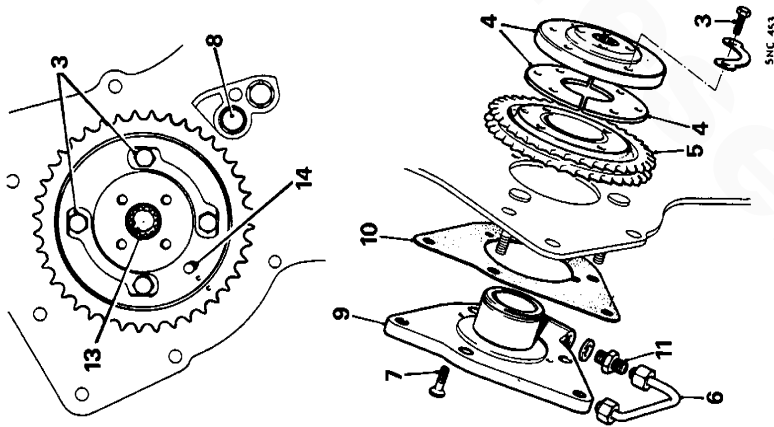

**OIL PUMP DRIVE SHAFT**

Remove and refit 12.10.30  
 Oil pump 12.60.26

**Removing**

- 1 **NA**
- 2 Drain the sump.
- 3 Disconnect the oil cooler pipe from the LH side of the crankcase.
- 4 Release the oil pipe clip from the gearbox mounting plate and move the oil pipe aside.
- 5 Remove the sump.
- 6 Remove the oil strainer and gasket.
- 7 Remove the three oil pump securing nuts.
- 8 Withdraw the oil pump and its drive shaft.
- 9 Withdraw the drive shaft from the oil pump.
- 10 Remove the oil pump gasket.

**Refitting**

- 11 Reverse the procedure in 1 to 10, tightening the oil pump securing nuts to 16 lbf ft (2.2 kgf m, 22 Nm).

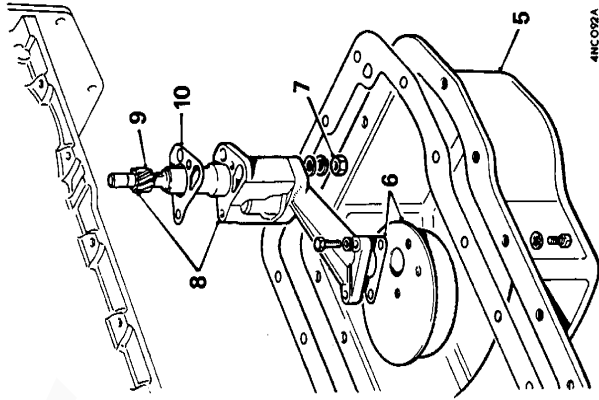

**TAPPETS**

Remove and refit 12.29.57  
 Camshaft 1 to 17 and 20 to 32 12.13.02

Service tool: 18G 694

**Removing**

- 1 **NA**
- 2 Drain the sump.
- 3 **NA**
- 4 Remove the timing chain and the camshaft gear, see 12.65.12.
- 5 Remove the camshaft locating plate.
- 6 Remove the fuel lift pump.
- 7 Remove the rocker cover and gasket.
- 8 Slacken evenly and remove the eight nuts retaining the rocker shaft brackets.
- 9 Remove the locking plate from the rocker shaft rear bracket.
- 10 Remove the rocker shaft assembly and the shim under each centre bracket.
- 11 Withdraw the push-rods and retain their order for refitting.

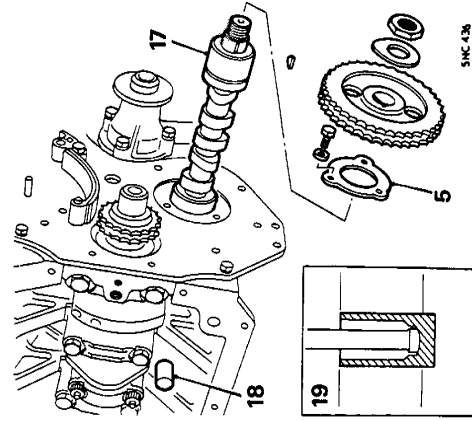



- 12 Lay the engine on its side with the cylinder head slightly downwards.
- 13 Withdraw the dipstick.
- 14 Remove the sump.
- 15 Remove the oil pump and its drive shaft.
- 16 Rotate the camshaft to position all the tappets away from their cams.
- 17 Withdraw the camshaft.
- 18 Withdraw the tappets and retain their order for refitting.

**Refitting**

- 19 Fit the tappets with their open ends towards the cylinder head.
- 20 Fit the camshaft.
- 21 Fit the oil pump and its drive shaft, tightening the retaining nuts to 16 lbf ft (2.2 kgf m, 22 Nm).
- 22 Fit the sump.
- 23 Fit the dipstick.
- 24 Place the engine in an upright position.
- 25 Fit the push-rods.
- 26 Fit the rocker shaft assembly, noting:
  - a Ensure that the shim is fitted under both centre brackets.
  - b Fit the locking plate to the rear bracket.
  - c Tighten the cylinder head nuts to 75 lbf ft (10.4 kgf m, 102 Nm) in the sequence shown, using tool 18G 694 to reach the centre row.
  - d Tighten the rocker bracket nuts to 25 lbf ft (3.5 kgf m, 34 Nm).
- 27 Fit the fuel lift pump.
- 28 Fit the camshaft locating plate.
- 29 Fit the camshaft gear, timing chain, and timing gear cover, see 12.65.12.
 

**NOTE:** Do not leave the crankshaft pulley in position.
- 30 Adjust the valve rocker clearance, see 12.29.48.
- 31 Fit the rocker cover and its gasket.
- 32 **NA**
- 33 Run the engine for a minimum of 5 miles, 8 km or 15 mins and on return slacken the cylinder head nuts approximately  $\frac{1}{8}$  of a turn in the sequence shown before retightening them to 75 lbf ft (10.4 kgf m, 102 Nm) in the sequence shown. Check the valve rocker clearances.

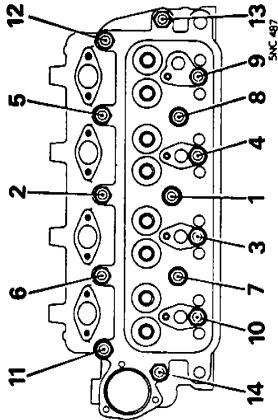

**CAMSHAFT BEARINGS**

**Remove and refit** 12.13.13  
 Service tools: 18G 55 A, 18G 123 A, 18G 123 B, 18G 123 E, 18G 123 F, 18G 123 L, 18G 123 T, 18G 123 AB, 18G 123 AC, 18G 123 AD, 18G 124 A, 18G 124 B, 18G 124 C, 18G 124 F, 18G 124 H, 18G 134, 18G 134 CQ, 18G 284, 18G 284 A, 18G 284 AC, 18G 694, 18G 1108, 18G 1195

**Removing**

- 1 **NA**
- 2 Drain the sump.
- 3 **NA**
- 4 Remove the flywheel.
- 5 Remove the crankshaft rear oil seal retainer.
- 6 Remove the bolts securing the gearbox adaptor plate and pull the adaptor plate off its two locating dowels.
- 7 Remove the two adaptor plate gaskets.
- 8 Remove the alternator.
- 9 Remove the high-pressure pipes from the injectors and pump.
- 10 Remove the injection pump drive oil feed pipe.
- 11 Remove the timing chain and the camshaft gear, see 12.65.12.
- 12 Remove the camshaft locating plate.
- 13 Remove the chain vibration damper.
- 14 Remove the bolt securing each front mounting bracket to the crankcase.
- 15 Remove the two bolts securing the front mounting plate to the crankcase.

- 17 Lift off the front mounting plate, complete with injection pump, front mounting brackets, chain tensioner stop-pin, and chain tensioner shoe.
- 18 Remove the fuel lift pump.
- 19 Withdraw the dipstick.
- 20 Release the dipstick tube from the cylinder head nut and withdraw the tube from the crankcase.
- 21 Disconnect and remove No. 1 heater plug.
- 22 Remove the rocker cover and gasket.
- 23 Remove the rocker shaft assembly, noting the locking plate on the rear bracket and the shim under each centre bracket.
- 24 Withdraw the push-rods, retaining their order for refitting.
- 25 Remove the cylinder head nuts.
- 26 Lift off the cylinder head.
 

**NOTE:** The combustion chamber inserts may drop out of the cylinder head as it is lifted; they **MUST** be refitted in their original positions.
- 27 Remove the cylinder head gasket.
- 28 Lay the engine on its side with the cylinder head face slightly downwards.
- 29 Remove the sump.
- 30 Remove the oil pump and its drive shaft.
- 31 Remove the big-end bearing caps and bearing halves.
- 32 Remove the main bearing caps and bearing halves, using tools 18G 284, 18G 284 A, and 18G 284 AC.
- 33 Lift out the crankshaft and remove the bearing and thrust washer halves.
- 34 Withdraw the connecting rod and piston assemblies.
- 35 Rotate the camshaft to position all the tappets away from their cams.
- 36 Withdraw the camshaft.
- 37 Withdraw the tappets and retain their order for refitting.
- 38 Remove the camshaft front bearing liner, using tools 18G 124 A and 18G 124 F as shown.
- 39 Remove the camshaft rear bearing liner, using tools 18G 124 A and 18G 124 B as shown.
- 40 Remove the camshaft centre bearing liner, using tools 18G 124 A, 18G 124 C, and 18G 124 H as shown.

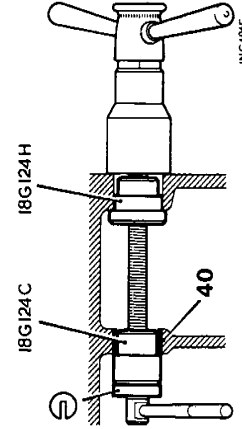
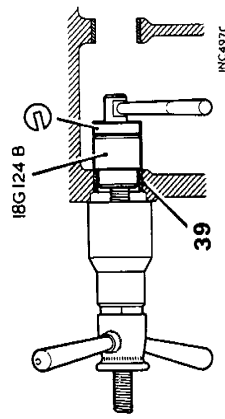
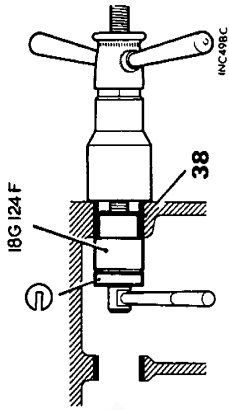

**Refitting**

**NOTE:** When fitting each new bearing liner ensure that its oil holes are lined up with those in the crankcase.

41 Fit a new camshaft front bearing liner, using tools 18G 124 A and 18G 124 F as shown.

42 Fit a new camshaft rear bearing liner, using tools 18G 124 A and 18G 124 B as shown.

43 Fit a new camshaft centre bearing liner, using tools 18G 124 A, 18G 123 C, and 18G 124 H as shown.

**NOTE:** Lightly lubricate the arbor before assembling the cutters and pilots to it. Feed the reamers very slowly and keep the cutters dry.

Keep the cutter flutes clear of swarf during reaming.

44 Ream the front and rear bearing liners using tools 18G 123 A, 18G 123 L, 18G 123 E (in position '10' on the arbor), 18G 123 AB, 18G 123 B (in position '6' on the arbor), and 18G 123 AC as shown.

45 Ream the centre bearing liner, using tools 18G 123 A, 18G 123 T, 18G 123 F (in position '9' on the arbor), and 18G 123 AD as shown.

46 Ensure that the oil holes of the bearing liners are still lined up with those in the crankcase.

47 Thoroughly clean all swarf from the cylinder block and crankcase.

48 Fit the tappets with their open ends towards the cylinder head.

49 Fit the camshaft.

50 Fit the connecting rod and piston assemblies with the combustion cavities on the R.H. side of the engine, using tool 18G 55 A.

51 Fit the crankshaft main bearings, and thrust washers (grooved side towards the crankshaft) to the crankcase.

52 Fit the main bearing caps, noting:

a Caps Nos. 2 and 4 are each stamped with their number.

b Fit caps 2, 3 and 4 with the cast word 'FRONT' towards the front of the engine.

c Using a straight-edge, align the front and rear bearing caps with the front and rear faces of the crankcase.

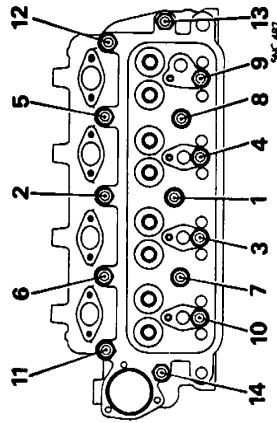
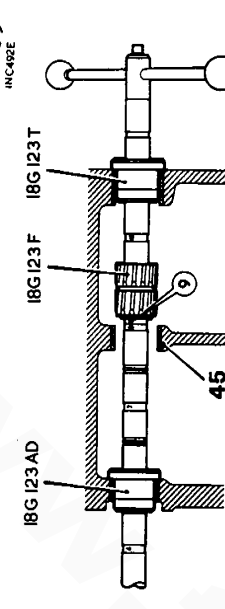
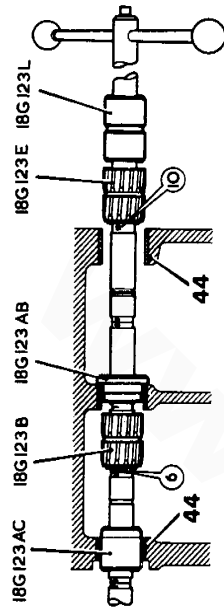
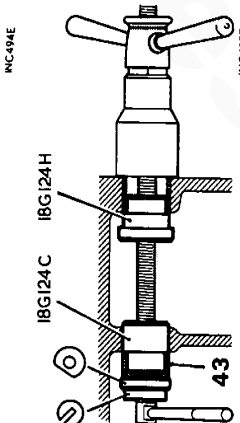
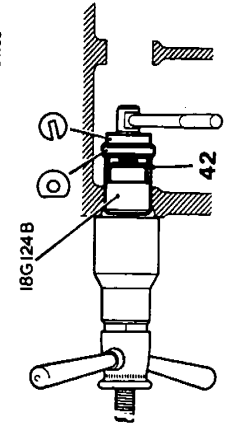
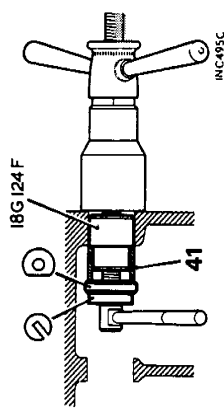

59 Position the front mounting plate assembly on the engine and locate it by fitting the camshaft locating plate bolts and the chain tensioner retaining screw.

60 Fit the two bolts to secure the mounting plate to the crankcase.

61 Fit the two bolts to secure both front mounting brackets to the crankcase.

62 Fit the chain vibration damper.

63 Fit the camshaft locating plate.

64 Fit the camshaft gear, timing chain, and timing gear cover, see 12.6.5.12.

**NOTE:** Do not leave the crankshaft pulley in position.

65 Reverse the procedure in 18 to 27, noting:

a Fit the cylinder head gasket with the face marked 'TOP' uppermost.

b Ensure that the combustion chamber inserts are fitted flush with the cylinder head face.

c Leave the cylinder head nuts finger tight until the rocker shaft assembly has been fitted.

d Tighten the cylinder head nuts to 75 lbf ft (10.4 kgf m, 102 Nm) in the sequence shown, using tool 18G 694 to reach the centre row.

d Tighten the main bearing bolts to 75 lbf ft (10.4 kgf m, 102 Nm).

53 Check the crankshaft end-float against the figure in DATA, and fit alternative thrust washers if necessary.

54 Fit the big-end bearings and caps, ensuring that the connecting rod and cap markings are aligned.

55 Tighten the big-end nuts to 35 lbf ft (4.8 kgf m, 47 Nm).

56 Fit the oil pump and its drive shaft, tightening the retaining nuts to 16 lbf ft (2.2 kgf m, 22 Nm).

57 Soak the cork sealing strips in engine oil, then fit them to the front and rear main bearing caps.

58 Fit the sump.

e Tighten the rocker bracket nuts to 25 lbf ft (3.5 kgf m, 34 Nm).

f Adjust the valve rocker clearance, see 12.29.48.

g Apply Loctite to the bottom of the dipstick tube.

66 Reverse the procedure in 4 to 11, noting:

a Use tools 18G 134 and 18G 134 CQ to fit the new rear oil seal.

b Use tool 18G 1108 to protect the seal when fitting the adaptor plate.

c Tighten the adaptor plate bolts to 30 lbf ft (4.2 kgf m, 41 Nm). **NOTE:** Fit the two longer bolts in the two top holes.

- d Tighten the oil seal retainer bolts to 20 lbf ft (2.8 kgf m, 27 Nm).
- e Tighten the flywheel bolts to 40 lbf ft (5.5 kgf m, 54 Nm).

67 Fit the engine.

68 Run the engine for a minimum of 15 mins and on return slacken the cylinder head nuts approximately 1/4 of a turn in the sequence shown before retightening them to 75 lbf ft (10.4 kgf m, 102 Nm) in the sequence shown. Check the valve rocker clearances.

**DATA**

Camshaft bearing inside diameters (reamed in position):

- Front . . . . .
- Centre . . . . .
- Rear . . . . .
- Crankshaft end-float . . . . .
- Thrust washer thicknesses . . . . .

- 1.79025 to 1.79075 in (45.47 to 45.48 mm)
- 1.73025 to 1.73075 in (43.95 to 43.96 mm)
- 1.62425 to 1.62475 in (40.26 to 40.27 mm)
- 0.001 to 0.0055 in (0.03 to 0.14 mm)
- 0.0885 to 0.0905 in (2.25 to 2.30 mm),
- 0.091 to 0.093 in (2.31 to 2.36 mm) and
- 0.0935 to 0.0955 in (2.37 to 2.43 mm)

**CONNECTING RODS AND PISTONS**

Remove and refit 12.17.01

Service tool: 18G 55 A

**Removing**

- 1 NA
- 2 Drain the sump.
- 3 Drain the cooling system.
- 4 Remove the cylinder head gasket, see 12.29.02.
- 5 Disconnect the oil cooler pipe from the L.H. side of the crankcase.
- 6 Release the oil cooler pipe clip from the gearbox mounting plate and move the oil pipe aside.
- 7 Remove the sump.
- 8 Remove the big-end nuts.
- 9 Remove the big-end caps and bearing halves.
- 10 Withdraw the connecting rod and piston assemblies.
- 11 Mark the pistons and connecting rods for reassembly.
- 12 Remove the circlips and the gudgeon pins and separate the pistons from the connecting rods.

**Refitting**

- 13 Reverse the procedure in 8 to 12, noting:
  - a Assemble the pistons to the connecting rods with the combustion cavities on the oil hole side of the connecting rods. If new piston rings are being used ensure that the ring gaps are correct, see 12.17.10.
  - c Use tool 18G 55 A to compress the piston rings.
  - d Fit the connecting rod and piston assemblies with the combustion cavities on the R.H. side of the engine.
- 14 If the connecting rods or piston(s) have been renewed, rotate the crankshaft and measure the amount by which each piston stands proud of the cylinder block face at T.D.C.
- 15 If piston stand-proud is outside the limits given in DATA, fit suitable alternative piston(s) from the range available.

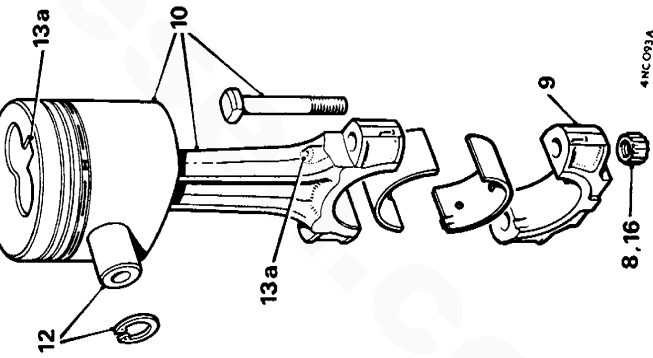

**DATA**

Piston stand-proud . . . . . 0.013 to 0.021 in (0.33 to 0.53 mm)

**CONNECTING RODS AND PISTONS**

Overhaul 12.17.10  
 Connecting rods 1 to 5 and 10 to 12  
 Pistons 1 to 9 and 12

- 1 **NA**
- 2 Drain the sump.
- 3 Drain the cooling system.
- 4 Remove the cylinder head gasket, see 12.29.02.
- 5 Remove and separate the connecting rods and pistons, see 12.17.01.
- 6 Remove the rings from the pistons.
- 7 Check the piston ring gaps, in an unworn part of the cylinder bore, against the figures in DATA. If necessary, increase the gap(s) by filing the end of the ring(s).
- 8 Fit the piston rings, noting:
  - a Fit the oil control ring expander latch pin first, ensuring that the latch pin enters both ends of the spring.
  - b Fit the oil control ring with its gap 180° from the expander latch pin.
  - c Fit the second ring with the word "TOP" uppermost.

**DATA**

**Connecting rod alignment**  
 Maximum out-of-parallel of big-end and little-end . . . . .

**Connecting rod bush**  
 Clearance on gudgeon pin . . . . .  
 Inside diameter (reamed after fitting) . . . . .

**Piston rings**

Fitted gap:  
 Top compression . . . . .  
 Second compression . . . . .  
 Oil control . . . . .  
 Ring to groove clearance:  
 Top compression . . . . .  
 Second compression . . . . .  
 Oil control . . . . .

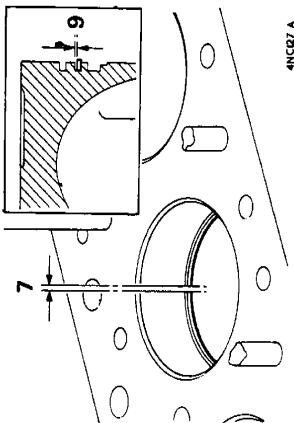

- 9 Check the piston ring groove clearance against the figures in DATA.
- 10 Check the gudgeon pin clearance in the connecting rod bush (see DATA). If the clearance is excessive, renew the bush, noting:
  - a Position the bush with its hole and oil grooves towards the top.
  - b Finish-ream the bush to the dimension given in DATA.
- 11 Ensure that the connecting rod alignment is within the figure given in DATA.
- 12 Reverse the procedure in 1 to 5.

**CRANKSHAFT REAR OIL SEAL**

Remove and refit 12.21.20  
 Gearbox adaptor plate 12.53.03  
 Flywheel 1 to 8 and 15 12.53.07  
 Service tools: 18G 134, 18G 134 CQ, 18G 1108

**Removing**

- 1 **NA**
- 2 Remove the gearbox.
- 3 Remove the damper.
- 4 Remove the flywheel securing bolts.
- 5 Lift off the flywheel.
- 6 Remove the oil seal retainer.
- 7 Remove the bolts securing the gearbox adaptor plate.
- 8 Pull the adaptor plate off its two locating dowels.
- 9 Remove the two adaptor plate gaskets.
- 10 Remove the oil seal from the adaptor plate.

**Refitting**

- 11 Fit the new oil seal flush with the rear face of the adaptor plate, using tools 18G 134 and 18G 134 CQ.
- 12 Reverse the procedure in 1 to 10, noting:
  - a Use tool 18G 1108 to protect the oil seal when fitting the adaptor plate.
  - b Tighten the adaptor plate bolts to 30 lbf ft (4.2 kgf m, 41 Nm).  
**NOTE:** Fit the two longer bolts in the two top holes.
  - c Tighten the oil seal retainer bolts to 20 lbf ft (2.8 kgf m, 27 Nm).
  - d Tighten the flywheel bolts to 40 lbf ft (5.5 kgf m, 54 Nm).

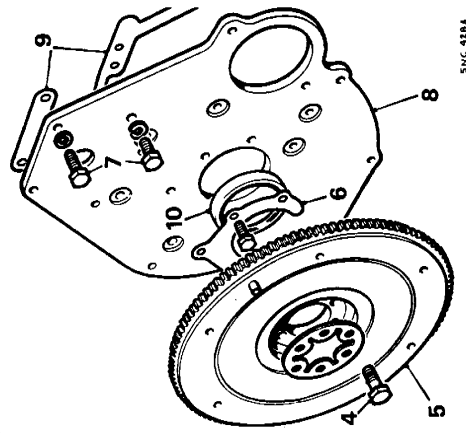

**CRANKSHAFT END-FLOAT**

Check and adjust 12.21.26

- 1 **NA**
- 2 Check the crankshaft end-float using a dial gauge against the crankshaft pulley bolt. If end-float is outside the limits given in DATA, change the thrust washers as described in the following paragraphs.
- 3 Drain the sump.
- 4 Release the oil pipe clip from the gearbox mounting plate and move the oil pipe aside.
- 5 Remove the sump.
- 6 Remove the oil pump and its drive shaft.
- 7 Remove the two bolts from the centre main bearing cap.
- 8 Remove the centre main bearing cap.
- 9 Remove the bottom halves of the thrust washers from the cap or crankshaft.
- 10 Slide the upper halves of the thrust washers around the crank and remove them.
- 11 Select a set of thrust washers to give the correct end-float (see DATA).
- 12 Reverse the procedure in 3 to 10, noting:
  - a Fit the thrust washers with their grooved sides towards the crankshaft.
  - b Fit the main bearing cap with the 'FRONT' mark towards the front of the engine.

**DATA**

Crankshaft end-float . . . . .

Thrust washer thicknesses . . . . .

0.001 to 0.0055 in (0.03 to 0.14 mm)  
 0.0885 to 0.0905 in (2.25 to 2.30 mm)  
 0.091 to 0.093 in (2.31 to 2.36 mm) and  
 0.0935 to 0.0955 in (2.37 to 2.43 mm)

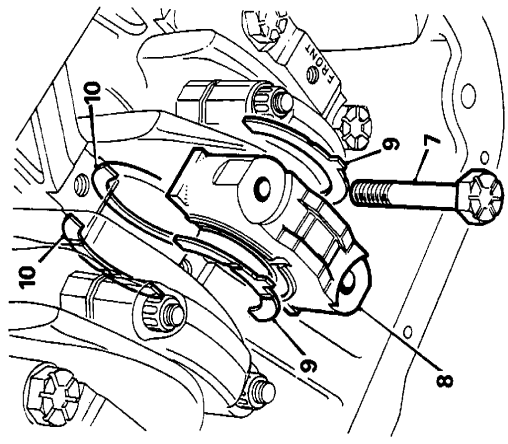

51C478

- c Tighten the main bearing cap bolts to 75 lbf ft (10.4 kgf m, 102 Nm).
- d Ensure that the end-float is correct after tightening the main bearing cap bolts.
- e Tighten the oil pump securing nuts to 16 lbf ft (2.2 kgf m, 22 Nm).

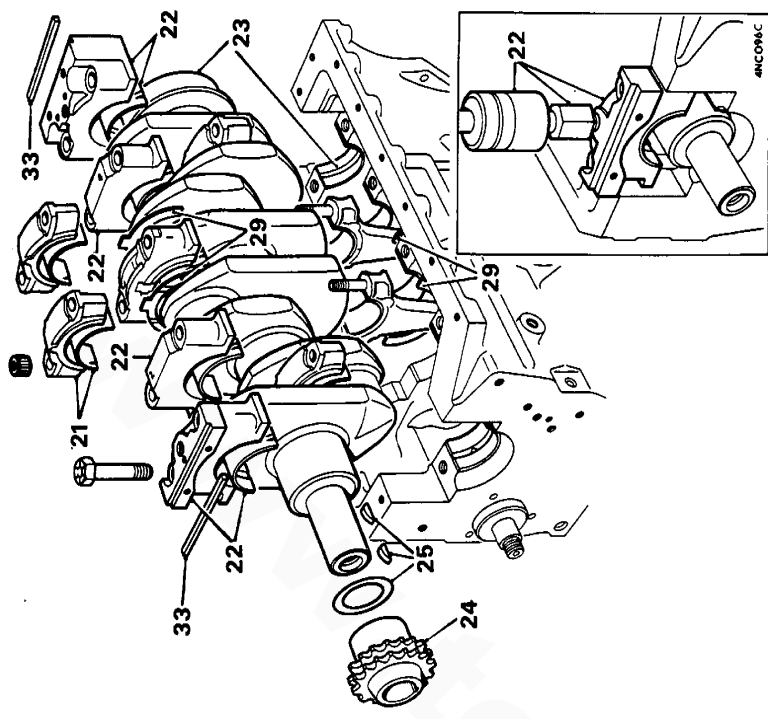

**CRANKSHAFT**

Remove and refit 12.21.33

Service tools: 18G 134, 18G 134 CQ, 18G 284, 18G 284 AC, 18G 1108, 18G 1195

**Removing**

- 1 **NA**
- 2 Drain the sump.
- 3 Remove the engine.
- 4 Remove the damper
- 5 Remove the flywheel.
- 6 Remove the crankshaft rear oil seal retainer.
- 7 Remove the bolts securing the gearbox adaptor plate and pull the adaptor plate off its two locating dowels.
- 8 Remove the two adaptor plate gaskets.

- 9 Remove the alternator.
- 10 Disconnect the high-pressure pipes from the injectors.
- 11 Remove the injection pump drive oil feed pipe.
- 12 Remove the timing chain and the camshaft gear, see 12.65.12.
- 13 Remove the camshaft locating plate.
- 14 Remove the chain vibration damper.
- 15 Remove the bolt securing each front mounting bracket to the crankcase.
- 16 Remove the two bolts securing the front mounting plate to the crankcase.
- 17 Lift off the front mounting plate, complete with injection pump, front mounting brackets, chain tensioner stop-pin, and chain tensioner shoe.
- 18 Withdraw the dipstick.
- 19 Remove the sump.

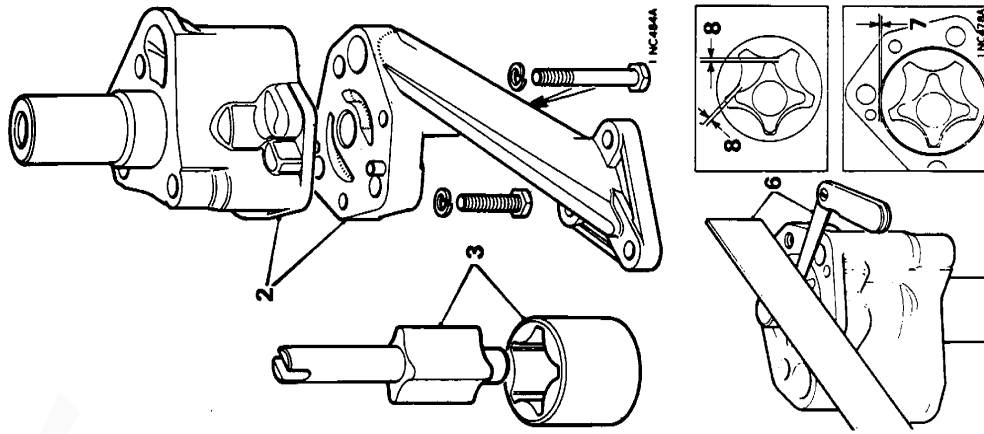

**OIL PUMP**

**Overhaul**

12.60.32

**Dismantling**

- 1 Remove the oil pump, see 12.10.30.
- 2 Remove the cover from the pump body.
- 3 Remove the rotors from the pump body.

**NOTE:** The cover is located by two dowels.

**Inspection**

- 4 Clean the components.
- 5 Fit the rotors to the pump body with the chamfered end of the outer rotor at the closed end of the body.
- 6 Check the end-float of the inner and outer rotors.
- 7 Check the outer rotor to pump body diametrical clearance.
- 8 Check the rotor lobe clearances.
- 9 Renew the pump assembly if the clearances or end-floats in 6 to 8 exceed the figure given in DATA.

**Reassembling**

- 10 Lubricate all components with clean engine oil.
- 11 Reverse the procedure in 1 to 3, ensuring that the outer rotor is fitted with its chamfer at the closed end of the body.

**DATA**

Outer rotor end-float	0.005 in (0.13 mm)
Inner rotor end-float	0.005 in (0.13 mm)
Outer rotor to pump body diametrical clearance	0.010 in (0.25 mm)
Rotor lobe clearance	0.006 in (0.15 mm)

- 32 Fit the oil pump and its drive shaft, tightening the retaining nuts to 16 lbf ft (2.2 kgf m, 22 Nm).

- 33 Soak the cork sealing strips in engine oil, then fit them to the front and rear main bearing caps.

- 34 Fit the dipstick.

- 35 Position the front mounting plate assembly on the engine and locate it by fitting the camshaft locating plate bolts and the chain tensioner retaining screw.

- 37 Fit the two bolts to secure the front mounting plate to the crankcase.

- 38 Fit the two bolts to secure both front mounting plate to the crankcase.

- 39 Fit the chain vibration damper.

- 40 Fit the camshaft locating plate.

- 41 Fit the camshaft gear, timing chain, and timing gear cover, see 12.65.12.

- 42 **NOTE:** Do not leave the crankshaft pulley in position.

- Reverse the procedure in 4 to 11, noting:

- a Use tools 18G 134 and 18G 134 CQ to fit the new rear oil seal.

- b Use tool 18G 1108 to protect the seal when fitting the adaptor plate.

- c Tighten the adaptor plate bolts to 30 lbf ft (4.2 kgf m, 41 Nm).

- NOTE:** Fit the two longer bolts in the two top holes.

- d Tighten the oil seal retainer bolts to 20 lbf ft (2.8 kgf m, 27 Nm).

- e Tighten the flywheel bolts to 40 lbf ft (5.5 kgf m, 54 Nm).

- 2.1262 to 2.1270 in (54.01 to 54.03 mm)
- 1.8759 to 1.8764 in (47.64 to 47.66 mm)

- 0.001 to 0.0027 in (0.03 to 0.07 mm)

- 0.010 in (0.25 mm)

- 0.001 to 0.0055 in (0.03 to 0.14 mm)

- 0.0885 to 0.0905 in (2.25 to 2.30 mm),

- 0.091 to 0.093 in (2.31 to 2.36 mm) and

- 0.0935 to 0.0955 in (2.37 to 2.43 mm)

- 20 Remove the oil pump and its drive shaft.

- 21 Remove the big-end bearing caps and bearing halves.

**NOTE:** If the crankshaft has to be rotated, be careful not to apply any force which could cause damage if a piston touches a valve.

- 22 Remove the main bearing caps and bearing halves, using tools 18G 284 and 18G 284 AC on the front and rear caps if necessary.

- 23 Lift out the crankshaft and remove the bearing and thrust washer halves.

- 24 Remove the crankshaft gear.

- 25 Remove the crankshaft keys and lift off the shim(s).

**Refitting**

- 26 Fit the shim(s), keys and gear to the crankshaft.

- 27 Fit the crankshaft, main bearings, and thrust washers (grooved side towards the crankshaft) to the crankcase.

- 28 Fit the main bearing caps, noting:

- a Caps Nos. 2 and 4 are each stamped with their number.

- b Fit caps 2, 3, and 4 with the cast word 'FRONT' towards the front of the engine.

- c Using a straight-edge, align the front and rear bearing caps with the front and rear faces of the crankcase.

- d Tighten the main bearing bolts to 75 lbf ft (10.4 kgf m, 102 Nm).

- 29 Check the crankshaft end-float against the figure in DATA, and fit alternative thrust washers if necessary.

- 30 Fit the big-end bearings and caps, ensuring that the connecting rod and cap markings are aligned.

- 31 Tighten the big-end nuts to 35 lbf ft (4.8 kgf m, 47 Nm).

**DATA**

Main journal diameter	.....
Crankpin diameter	.....
Clearance in bearings (journals and crankpin)	.....
Undersizes (journals and crankpins)	.....
Crankshaft end-float	.....
Thrust washer thicknesses	.....

- 18 Remove the front mounting plate gasket.
- Refitting**
- 19 Fit the front mounting plate gasket.
- 20 Position the front mounting plate assembly on the engine and locate it by fitting the camshaft locating plate bolts and the chain tensioner retaining screw.
- 21 Reverse the procedure in 1 to 16, noting:
  - a With the throttle cable connected ensure that the injection pump throttle lever is operated through its full range of movement by the throttle pedal.
  - b When the stop control cable is connected, ensure that the stop control has sufficient travel
- 22 Bleed the fuel system, see 19.50.07.

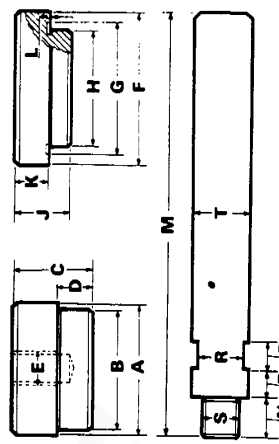

**Pistons**

Pressing-out pilot:

Pressing-in pilot:

Pilot extension:

A.	3.25	0.005	in
	(82.55)	0.13	mm
B.	3.157	-0.000	in
	(80.19)	+0.00	mm
C.	1.75		in (44.45 mm)
D.	0.75		in (19 mm)
E.	¼		in B.S.W. thread
F.	3.625		in (92.07 mm)
G.	3.312		in (84.14 mm)
H.	3.133	0.000	in
	(79.58)	+0.00	mm
J.	1.25		in (31.75 mm)
K.	0.75		in (19 mm)
L.	0.015		in (0.38 mm)
M.	14.50		in (36.83 cm)
N.	0.875		in (22.22 mm)
P.	0.625		in (15.87 mm)
Q.	0.625		in (15.87 mm)
R.	Two flats		1 in (25.4 mm) across
S.	¼		in B.S.W. thread
T.	1.25		in (31.75 mm)

3.1595 to 3.1606	in (80.25 to 80.28 mm)
0.040	in (1.02 mm)
3.2615 to 3.2620	in (82.84 to 82.86 mm)
3.2645 to 3.2660	in (82.92 to 82.96 mm)
3.1595 to 3.1606	in (80.25 to 80.28 mm)
0.020	in (0.51 mm)

**CYLINDER LINERS**

**Remove and refit** 12.25.26

**NOTE:** If the condition of the cylinder bores is such that they cannot be cleaned up to accept oversize pistons, dry cylinder liners can be fitted (see DATA).

Pistons should be made to the dimensions given, from case-hardening steel and case-hardened.

The pilot extension should be made from 55-ton hardening and tempering steel, hardened in oil, and then tempered at 550°C (1020°F).

**DATA**

**Cylinder block**

Bore: Standard . . . . .

Oversize maximum (without cylinder liner) . . . . .

To accept cylinder liner . . . . .

**Cylinder liners**

Outside diameter . . . . . n

Bore: Standard (machined after fitting) . . . . .

Oversize (maximum) . . . . .

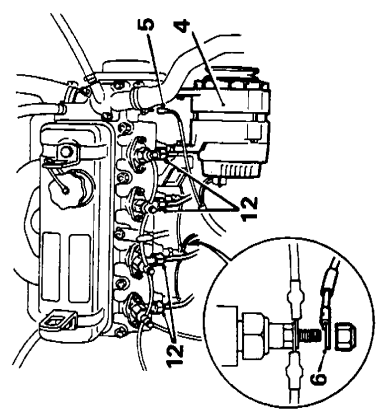

- 10 Disconnect the throttle cable from the injection pump lever.
- 11 Remove the injection pump drive oil feed pipe.
- 12 Disconnect the high-pressure pipes from the injectors.
- 13 Remove the two bolts and washers securing the front mounting plate to the crankcase.
- 14 Lift off the front mounting plate, complete with injection pump, front mountings, chain tensioner stop-pin, and chain tensioner shoe.

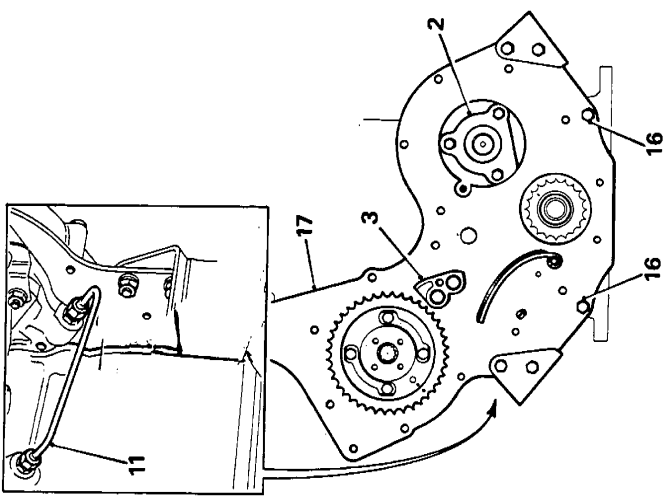

**ENGINE FRONT MOUNTING PLATE GASKET**

- Remove and refit** 12.25.10
- Removing**
- 1 Remove the timing chain and the camshaft gear, see 12.65.12.
  - 2 Remove the camshaft locating plate.
  - 3 Remove the chain vibration damper.
  - 4 Remove the alternator.
  - 5 Disconnect the thermal transmitter and move the wiring harness aside.
  - 6 Disconnect the supply lead from the heater plugs.
  - 7 Disconnect the fuel return pipe from the injection pump.
  - 8 Disconnect the fuel supply pipe from the injection pump.
  - 9 Disconnect the stop control cable from the injection pump.

**CYLINDER HEAD GASKET**

Remove and refit 12.29.02

Service tool: 18G 694

**Removing**

- 1 **NA**
- 2 Drain the cooling system.
- 3 Disconnect the hoses from the water outlet elbow.
- 4 Disconnect the breather hose from the cylinder side cover.
- 5 **NA**
- 6 **NA**

- 7 Disconnect the lead from the thermal transmitter.
- 8 Disconnect the supply lead from the heater plugs.
- 9 Disconnect the spill rail and return pipe from the injectors and lay the spill rail aside.
- 10 Remove Nos. 3 and 4 injector pipes.
- 11 Remove Nos. 1 and 2 injector pipes.
- 12 Remove the oil dipstick.
- 13 Release the dipstick tube from the cylinder head nut and withdraw the tube from the crankcase.
- 14 Disconnect and remove No. 1 heater plug.
- 15 Remove the rocker cover and gasket.
- 16 Remove the rocker shaft assembly, noting the locking plate on the rear bracket and the shim under each centre bracket.
- 17 Withdraw the push-rods, retaining their order for refitting.
- 18 Remove the cylinder head nuts.
- 19 Lift off the cylinder head.
- 20 **NOTE:** The combustion chamber inserts may drop out of the cylinder head as it is lifted; they **MUST** be refitted in their original positions.

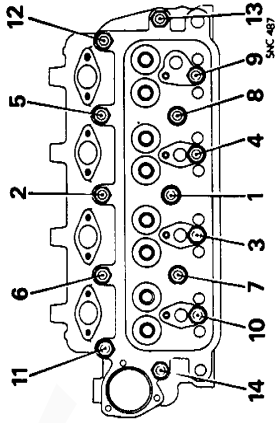
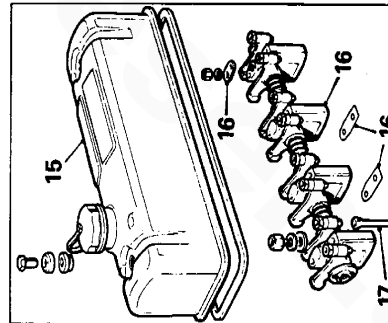
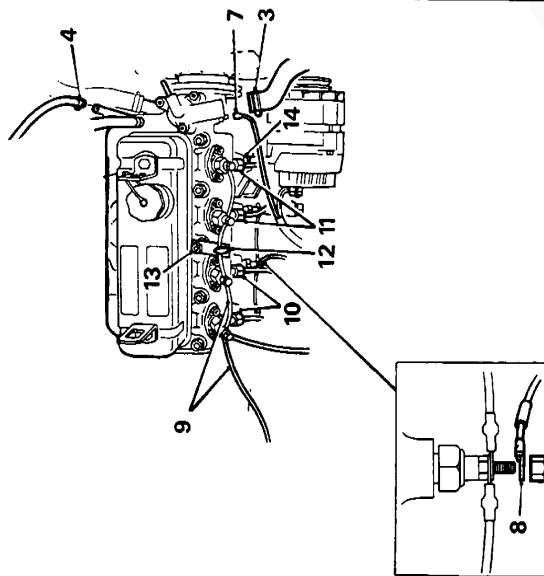
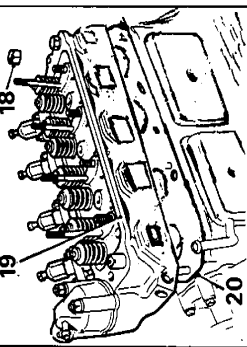

**Refitting**

- 21 Reverse the procedure in 1 to 20. **noting:**
  - a Fit the cylinder head gasket with the face marked 'TOP' uppermost.
  - b Ensure that the combustion chamber inserts are fitted flush with the cylinder head face.
  - c Leave the cylinder head nuts finger tight until the rocker shaft assembly has been fitted.
  - d Tighten the cylinder head nuts to 75 lbf ft (10.4 kgf m, 102 Nm) in the sequence shown, using tool 18G 694 to reach the centre row.
  - e Tighten the rocker brackets nuts to 25 lbf ft (3.5 kgf m, 34 Nm).
  - f Adjust the valve rocker clearance, see 12.29.48.
  - g Bleed the fuel system, see 19.50.05.
  - h Apply Loctite to the bottom of the dipstick tube.
- 22 Run the engine for a minimum of 15 mins and on return slacken the cylinder head nuts approximately 1/4 of a turn in the sequence shown before retightening them to 75 lbf ft (10.4 kgf m, 102 Nm) in the sequence shown. Check the valve rocker clearances.



**CYLINDER HEAD**

**Overhaul**

Service tools: 18G 27, 18G 29, 18G 45, 18G 167, 18G 167 A, 18G 167 B, 18G 167 C, 18G 174, 18G 174 A, 18G 174 B, 18G 174 C, 18G 174 D, 18G 284, 18G 284 P

- 1 Remove the cylinder head gasket, see 12.29.02.
- 2 Remove the three remaining heater plugs from the cylinder head.
- 3 Remove the injectors, using tools 18G 284, and 18G 284 P.
- 4 Remove the two sealing washers from each injector position.
- 5 Remove the heater hose from the cylinder head.
- 6 Remove the manifolds and gasket.
- 7 Mark the combustion chamber inserts for refitting in their original positions.
- 8 Remove the combustion chamber inserts, if necessary using a soft drift through the injector holes.
- 9 Push out the injector heat shields and their sealing washers.
- 10 Remove the water outlet elbow and its gasket.
- 11 Lift out the thermostat.
- 12 Remove the valves and their components, using tool 18G 45.

**NOTE:** Seals are fitted to the inlet valve guides.

- 13 If the valve guides are worn (see DATA), press them out in the direction of the valve seats.

14 To fit new valve guides, press them in from the top of the cylinder head until they protrude by the amount stated in DATA. Protrusion is measured from the top of the valve guide to the bottom of the counter bore for the valve spring.

15 Ream new valve guides to the size given in DATA.

16 Check the cylinder head face for flatness and, if necessary, reface the cylinder head without reducing its depth below the figure given in DATA.

**NOTE:** The combustion chamber inserts must be faced level with the cylinder head.

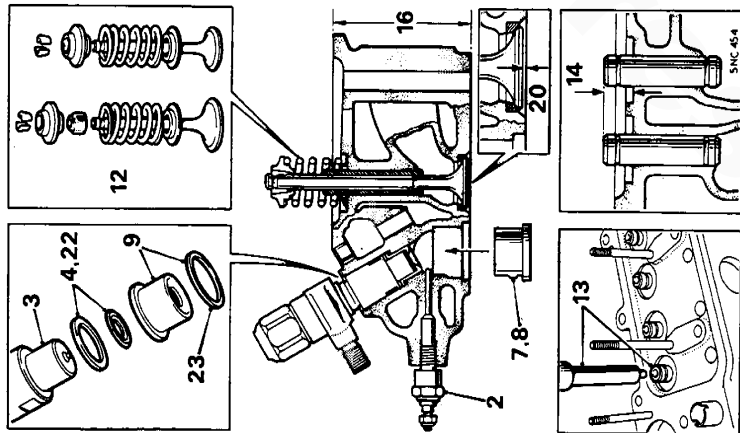

17 If necessary, reface the valves to the angle given in DATA, removing the minimum of material.

18 If necessary, recut the valve seats in the cylinder head, using the following tools:

- a 18G 27 Handle.
- b 18G 174 D Pilot.
- c 18G 174 A Glaze breaker for inlet seats.
- d 18G 174 Cutter for inlet seats.
- e 18G 174 B Top narrowing cutter for inlet seats.
- f 18G 174 C Bottom narrowing cutter for inlet seats.

- g 18G 167 A Glaze breaker for exhaust seats.
  - h 18G 167 Cutter for exhaust seats.
  - j 18G 167 B Top narrowing cutter for exhaust seats.
  - k 18G 167 C Bottom narrowing cutter for exhaust seats.
- 19 Lap the valves onto their seats, using tool 18G 29.
  - 20 Check the valve stand-down against the figure in DATA. If stand-down is excessive, even with a new valve fitted, renew the valve seat insert(s) and cut their seats.
  - 21 Renew the valve springs if they are not as specified in DATA.
  - 22 Renew the sealing washers for the injectors.
  - 23 Renew the sealing washers for the injector heat shields.
  - 24 Reverse the procedure in 1 to 12.

**DATA**

**Cylinder head**

Depth after refacing . . . . . 3.16 in (80.26 mm) minimum

**Valve guides**

Inside diameter (reamed after fitting) . . . . . 0.3441 to 0.3448 in (8.74 to 8.76 mm)  
 Protrusion (from bottom of counterbore) . . . . . 0.550 to 0.560 in (13.97 to 14.22 mm)

**Valves**

Seat angle . . . . . 45°  
 Stand-down . . . . . 0.0445 to 0.0505 in (1.13 to 1.28 mm)  
 Stem diameter: Inlet . . . . . 0.3428 to 0.3422 in (8.71 to 8.73 mm)  
                   Exhaust . . . . . 0.3422 to 0.3427 in (8.69 to 8.70 mm)

**Valve springs**

Free length (approximate) . . . . . 1 1/8 in (48.75 mm)  
 Load when compressed to 1.44 in (36.58 mm) . . . . . 82 lbf (37.195 kgf, 364N)

**VALVE CLEARANCE**

**Check and adjust** 12.29.48

**Checking**

- 1 Remove the rocker cover and gasket.
- 2 Check, and if necessary adjust, the clearance between the rocker arms and valve stems against the figure in DATA, working in the following order:

Check:

No. 1 valve with No. 8 valve fully open.	
3 "	6 "
5 "	4 "
2 "	7 "
8 "	1 "
6 "	3 "
4 "	5 "
7 "	2 "

**DATA**

Valve rocker clearance (cold) . . . . .

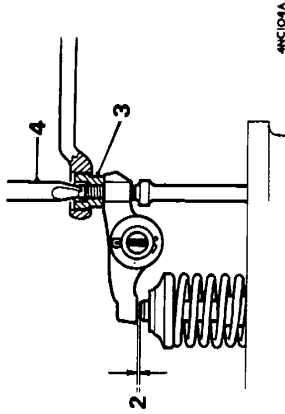

4NC104A

**Adjusting**

- 3 Slacken the locknut.
- 4 Rotate the adjusting screw to set the clearance.
- 5 Hold the adjusting screw against rotation and tighten the locknut.
- 6 Fit the rocker cover and gasket.

0.017 in (0.43 mm)

**Refitting**

- 7 Reverse the procedure in 1 to 6, noting:
  - a Tighten the cylinder head nuts to 75 lbf ft (10.4 kgf m, 102 Nm) in the sequence shown, using tool 18G 694 to reach the centre row.
  - b Tighten the rocker bracket nuts to 25 lbf ft (3.5 kgf m, 34 Nm).
  - c Adjust the valve rocker clearance, see 12.29.48.

- 8 Run the engine for a minimum of 11.5 mins and on return slacken the cylinder head nuts approximately 1/4 of a turn in the sequence shown before retightening them to 75 lbf ft (10.4 kgf m, 102 Nm) in the sequence shown. Check the valve rocker clearances.

**ROCKER SHAFT ASSEMBLY**

**Overhaul** 12.29.55

Service tools: 18G 226, 18G 226 A

**Dismantling**

- 1 Remove the rocker shaft, see 12.29.54.
- 2 Remove the split pin from each end of the rocker shaft.
- 3 Slide the components off the shaft.
- 4 Remove the locating screw from the rocker shaft rear bracket and remove the bracket.
- 5 Remove the adjuster screws.

**Inspection**

- 6 Clean the oilways of the rocker shaft.
- 7 Examine the rocker to valve contact faces for wear, and renew the rocker(s) if necessary.
- 8 Renew the rocker adjusting screws if they are worn or if the threads are damaged.
- 9 Press out worn rocker bushes, using tools 18G 226 and 18G 226 A.

**Reassembling**

- 10 Press in new rocker bushes, using tools 18G 226 and 18G 226 A, and ensuring that the bush joint and oil groove are in the positions shown.

**DATA**

Rocker shaft diameter . . . . .  
 Rocker bush inside diameter (reamed in position) . . . . .

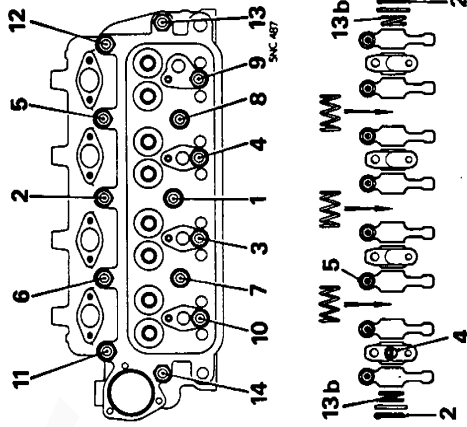

1 NC 316 B

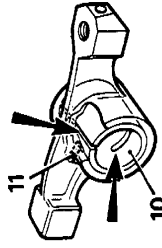

4NC408B

- 11 Drill a hole in the bush, through the hole in the top of the rocker barrel, using a 1.95 mm drill.
- 12 Burnish-ream the bush to the dimension given in DATA.
- 13 Reverse the procedure in 1 to 5,

- a The locating screw engages the larger of the two diametrically opposite holes.
- b The double-coil spring washers are fitted inside the plain washer at each end of the shaft.

0.624 to 0.625 in (15.85 to 15.87 mm)  
 0.6255 to 0.6260 in (15.89 to 15.90 mm)

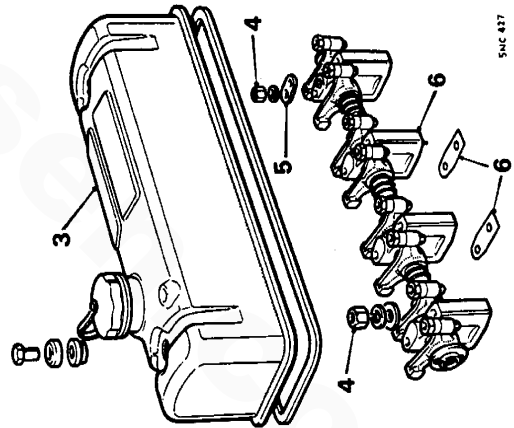

5NC 437

**ROCKER SHAFT ASSEMBLY**

**Remove and refit** 12.29.54

Service tool: 18G 694

**Removing**

- 1 NA
- 2 Drain the cooling system.
- 3 Remove the rocker cover and gasket.
- 4 Slacken evenly and remove the eight nuts retaining the rocker shaft brackets.
- 5 Remove the locking plate from the rocker shaft rear bracket.
- 6 Remove the rocker shaft assembly and the shim under each centre bracket.

**OIL PRESSURE RELIEF VALVE**

Remove and refit 12.60.56

Service tool: 18G 69

**Removing**

- 1 / NA
- 2 Remove the valve cap washer from the rear of the L.H. side of the crankcase.
- 3 Withdraw the spring from the crankcase.
- 4 Withdraw the valve plunger, using tool 18G 69.

**Refitting**

- 5 If the valve plunger is pitted, or is not seating correctly, lap the plunger onto its seating, using tool 18G 69. If lapping fails to correct the fault, renew the plunger and ensure that the new plunger seats correctly.
- 6 Renew the spring if it is not as specified in DATA.
- 7 Reverse the procedure in 1 to 4.

**DATA**

Relief valve spring:

- Free length . . . . .
- Load when compressed to 2.16 in (54,77 mm) . . . . .

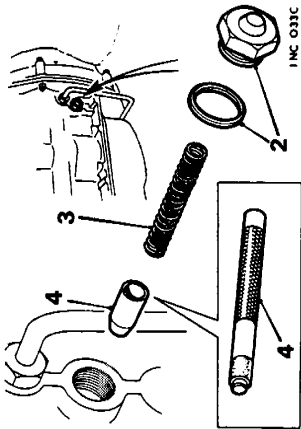

**TIMING GEAR COVER OIL SEAL**

Remove and refit 12.65.05

Service tools: 18G 98 A, 18G 134, 18G 134 BD

**Removing**

- 1 / NA
- 2 Slacken the alternator mounting bolts and remove the fan belt.
- 3 Remove the water pump pulley.
- 4 Remove the crankshaft pulley, using tool 18G 98 A.
- 5 Remove the timing gear cover and gasket.
- 6 Remove the oil seal from the timing cover.

**Refitting**

- 7 Fit the new oil seal to the timing gear cover, using tools 18G 134 and 18G 134 BD.
- 8 Fit the timing gear cover and gasket, using the crankshaft pulley to centralize the oil seal on the crankshaft.
- 9 Fit the timing gear cover bolts in the following illustrated positions.

- | Position   | Bolt size  |
|--|--|
| A  | $\frac{3}{8}$ in x $1\frac{1}{4}$ in (44.5 mm) long  |
| B  | $\frac{3}{8}$ in x 2 in (50 mm) long                 |
| <b>NOTE:</b> An 'O' ring is fitted on this bolt. |  |
| C  | $\frac{3}{8}$ in x 2 in (50 mm) long                 |
| D  | $\frac{3}{8}$ in x $2\frac{1}{4}$ in (57 mm) long    |
| E  | $\frac{1}{4}$ in x $1\frac{1}{4}$ in (44.5 mm) long  |
| F  | $\frac{1}{4}$ in x $1\frac{1}{4}$ in (31.75 mm) long |
- 10 Reverse the procedure in 1 to 4, tightening the crankshaft pulley bolt to 75 lbf ft (10.4 kgf m, 102 Nm).

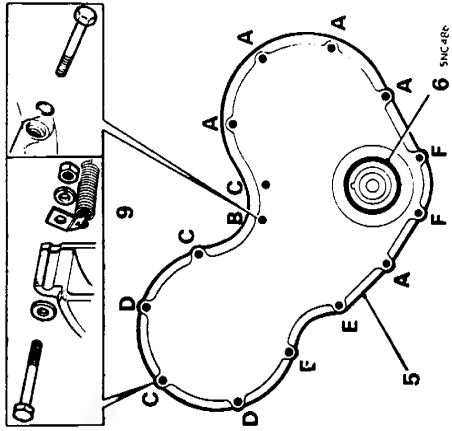

**TIMING CHAIN AND GEARS**

- Remove and refit 12.65.12
- Timing chain tensioner 1 to 14, 16 to 19, 34 to 40, and 43 to 47 12.65.28
- Timing chain 1 to 14, 16 to 22, 29 to 41, and 43 to 47 12.65.14
- Service tools: 18G 98 A, 18G 134, 18G 134 BD

**Removing**

- 1 / NA
- 2 Drain the cooling system.
- 3 Slacken the alternator mounting bolts and remove the fan belt.
- 4 Remove the water pump pulley.
- 5 Remove the crankshaft pulley, using tool 18G 98 A.
- 6 Remove the timing gear cover and gasket.
- 7 Remove the crankshaft oil thrower.
- 8 If the camshaft gear is to be removed, slacken the camshaft nut using tool 18G 98 A.
- 9 Rotate the crankshaft until the timing marks are positioned as shown.
- 10 Hold the chain tensioner and chain together by hand and remove the tensioner retainer screw.
- 11 Lift away the chain tensioner.

- 12 If the chain tensioner shoe is to be renewed, remove the circlip from the pivot pin and lift off the shoe.
  - 13 Remove the idler gear bolt.
  - 14 Lift away the idler gear and its hub.  
**NOTE:** The idler gear hub is located by a roll-pin dowel.
  - 15 Remove the timing chain.
  - 16 Remove the camshaft nut and gear.
  - 17 Remove the crankshaft gear.
- Refitting**
- 18 Fit the camshaft gear and secure it with its nut.
  - 19 Check the camshaft end-float against the figure in DATA. If end-float is excessive, remove the camshaft gear and renew the camshaft locating plate. Fit the camshaft gear and crankshaft gear to their shafts.
  - 21 Place a straight-edge across the tooth face of the gears and check their alignment; the crankshaft gear face should be rearward by the amount stated in DATA. If necessary, add or remove shims behind the crankshaft gear to set the alignment as near as possible to the DATA figure.
  - 22 Position the injection pump gear with its timing hole at approximately 7 o'clock and insert a  $\frac{3}{8}$  in (5.5 mm) peg through the hole to engage the hole in the engine front plate.
  - 23 Position the camshaft gear and crankshaft gear with their timing marks in the positions shown.
  - 24 Fit the timing chain and place the idler gear (without its hub) in position on the chain.
  - 25 Adjust the position of the chain, without rotating the gears, to permit the idler gear hub to be fitted without chain slack between the idler and its adjacent gears.  
**NOTE:** The idler gear hub is located by a roll-pin dowel.
  - 26 Fit the idler gear bolt and tighten it to 30 lbf ft (4.1 kgf m, 41 Nm).

**DATA**  
Camshaft end-float .....  
Timing gear alignment .....

- 27 Fit the chain tensioner shoe and circlip to the pivot pin.
- 28 Fit the spring, pressure block, and centre pin to the chain tensioner body. Compress the spring and rotate the centre pin 180° to retain the compressed position.
- 29 Fit the pressure lever to the chain tensioner with the lever legs forward of the tensioner body, i.e. the tensioner body will contact the engine front plate when fitted.
- 30 Fit the retaining screw through the pressure lever and tensioner body.
- 31 Fit the compressed chain tensioner and tighten its retaining screw.
- 32 Rotate the centre pin 180° to release the tensioner.
- 33 Ensure that the timing marks are still correctly positioned.
- 34 Remove the peg from the injection pump gear.
- 35 Tighten the camshaft nut to 65 lbf ft (9 kgf m, 88 Nm).
- 36 Fit the crankshaft oil thrower with its dished side towards the gear.
- 37 Renew the timing gear cover oil seal, using tool 18G 134 and 18G 134 BD.
- 38 Fit the timing gear cover and gasket, using the crankshaft pulley to centralize the oil seal on the crankshaft.
- 39 Fit the timing cover bolts in the following illustrated positions.

- Position Bolt size**
- A  $\frac{5}{8}$  in x 1  $\frac{1}{2}$  in (44.5 mm) long
  - B  $\frac{5}{8}$  in x 2 in (50 mm) long
- NOTE:** An 'O' ring is fitted on this bolt
- C  $\frac{5}{8}$  in x 2 in (50 mm) long
  - D  $\frac{5}{8}$  in x 2  $\frac{1}{4}$  in (57 mm) long
  - E  $\frac{1}{4}$  in x 1  $\frac{1}{2}$  in (44.5 mm) long
  - F  $\frac{1}{4}$  in x 1  $\frac{1}{2}$  in (31.75 mm) long
- 40 Reverse the procedure in 1 to 5, tightening the crankshaft pulley bolt to 75 lbf ft (10.4 kgf m, 102 Nm).

0.003 to 0.007 in (0.08 to 0.18 mm)  
Crankshaft gear 0.005 in (0.13 mm) rearward of camshaft gear

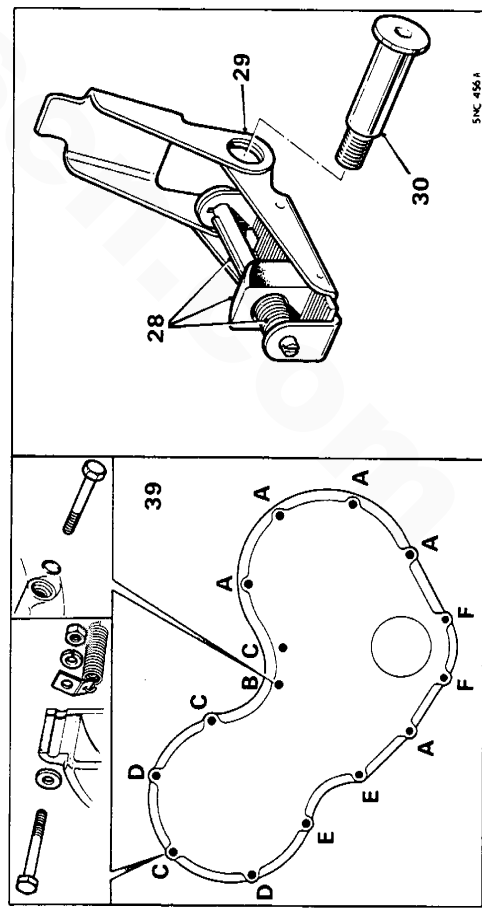
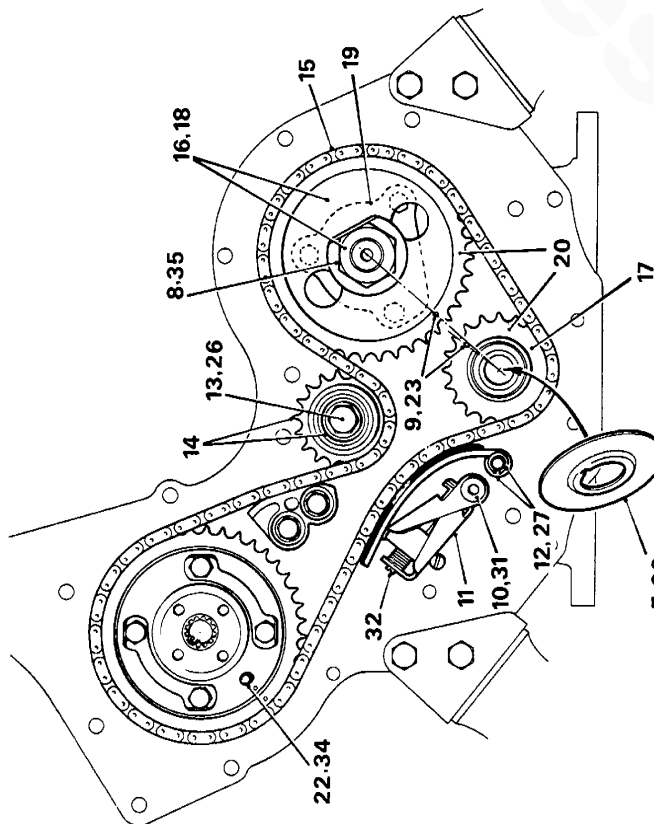

**HYDRAULIC TYPE ONLY****INJECTION PUMP**

Remove and refit 19.30.07

Timing — check and adjust  
1 to 16 and 21 to 38 19.30.01

Service tools: AMK 9990, MS 67 A

**Removing**

- 1 Slacken the alternator mounting bolts and remove the fan belt.
- 2 Remove the alternator.
- 3 Disconnect the fuel return pipe from the injection pump.
- 4 Disconnect the fuel supply pipe from the injection pump.
- 5 Disconnect the stop control cable from the injection pump.
- 6 Disconnect the throttle cable from the injection pump
- 7 Disconnect the lead from the **fuel pressure switch**
- 8 Remove the injection pump stop lever return spring.
- 9 Remove Nos. 3 and 4 injector pipes.
- 10 Remove Nos. 1 and 2 injector pipes.
- 11 Remove the three nuts and washers securing the injection pump and withdraw the injection pump from the engine.

- 12 The lower nut also secures the anchor bracket for the stop lever return spring.
- 13 Withdraw the injection pump torsion bar.
- 14 Remove the injection pump gasket.

14 — 20 MA

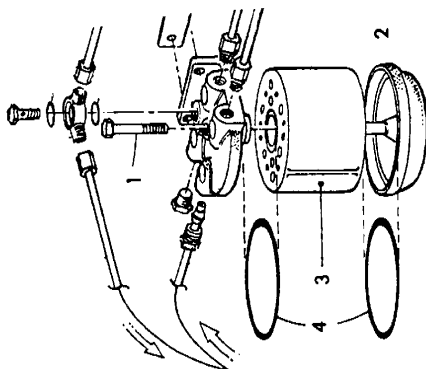
**FUEL FILTER ELEMENT**

Remove and refit 19.25.07

- 1 Support the filter base and unscrew the centre bolt in the filter head.
- 2 Detach the filter base.
- 3 Remove the element, using a twisting motion.
- 4 Remove the seals from the filter base and filter head.

**Refitting**

- 5 Clean the filter base.
- 6 Reverse the procedure in 1 to 4, using a new element and seals.
- 7 Bleed the fuel system, see 19.50.07.

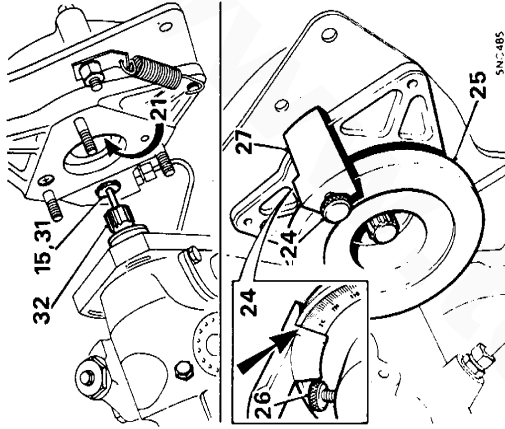
**Refitting**

- 21 Rotate the crankshaft until the master spline in the injection pump drive is in the 12 o'clock position.
- 22 Insert timing pin AMK 9990 into the timing hole in the gearbox adaptor plate. The hole is situated below the sump flange on the RH side.
- 23 Maintain a light pressure on the timing pin and rotate the crankshaft in the normal direction of rotation until the timing pin engages the timing hole in the flywheel. The master spline in the injection pump drive should now be in the 8 o'clock position when viewed from the rear.

- 24 Assemble the long scribing guide of tool MS 67A to the tool body, set it on the 204° position and lock it with its knurled screw.
- 25 Insert the assembled tool into the injection pump position on the engine, engaging the injection pump drive splines.
- 26 Slide the body of the tool along its centre bar until the body engages the injection pump drive gear hub. Lock the centre bar with the knurled screw.
- 27 Apply gentle clockwise (viewed from the rear) pressure to the tool and check that the scribed line (timing mark) on the drive gear hub lines up with the scribing guide of the tool. If necessary, scribe a new mark.
- 28 Remove tool MS 67A.
- 29 Remove timing pin AMK 9990.
- 30 Fit the injection pump gasket to the drive gear hub.
- 31 Fit the torsion bar into the drive flange on the engine.
- 32 Position the injection pump drive shaft so that its master spline lines up with that on the drive flange.
- 33 Fit the injection pump drive shaft over the end of the torsion bar and **VERY GENTLY** engage the drive shaft splines with the drive flange splines.
- 34 Push the injection pump as far into position as possible and fit the spring anchor bracket, washers, and nuts.
- 35 Progressively tighten the three nuts to pull the injection pump fully into position, ensuring that the timing marks on the pump and drive flange are aligned.
- 36 Reverse the procedure in 1 to 10
- 37 Bleed the fuel system, see 19.50.07.

### LIFT PUMP

Remove and refit 19.45.09

#### Removing

- 1 **NA** Disconnect the two pipes from the lift pump.
- 2 Plug the supply pipe from the fuel tank.
- 3 Remove the securing nuts and washers.
- 4 Remove the lift pump and gasket.

#### Refitting

- 5 Reverse the procedure in 1 to 3.
- 6 Bleed the fuel system, see 19.50.07.

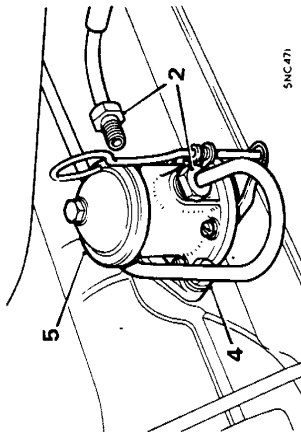

51C471

### LIFT PUMP

Overhaul 19.45.16

#### Dismantling

- 1 Remove the lift pump, see 19.45.09.
- 2 Scribe a reassembly mark across the body joint flanges.
- 3 Remove the domed cover and sealing ring.
- 4 Remove the filter.
- 5 Remove the securing screws and separate the top and bottom halves of the pump.
- 6 If the valves require renewing, lever them out carefully.
- 7 Remove the valve gaskets.
- 8 Press the diaphragm downwards, rotate it through 90° and withdraw it.
- 9 Lift out the diaphragm spring.
- 10 If the diaphragm rod seal is to be renewed, carefully withdraw the seal retainer.
- 11 Lift out the seal.
- 12 If the rocker arm pin or linkage is to be renewed, secure the rocker arm in a vice and tap the face of the pump mounting flange to dislodge the rocker arm pin and its components.

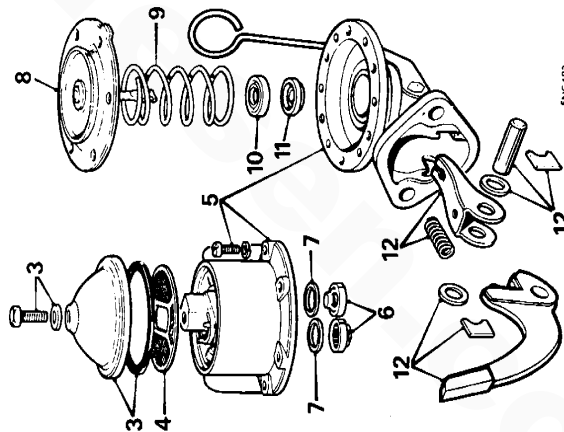

51C483

#### Reassembling

- 13 Renew any components which are worn or damaged.
- 14 Reverse the procedure in 1 to 12, noting:
  - a If the diaphragm spring is renewed, ensure that the new spring is of the same colour as the original.
  - b If the valves are renewed, ensure that they are fitted to operate in the correct directions and staked in.

**NOTE:** The inlet port is indicated by an arrow on the pump body.

**FUEL SYSTEM**

**Bleeding**

19.50.07

**NOTE:** After renewing the fuel filter element it will only be necessary to bleed the fuel filter as described in 1 and 2, provided that the engine has not been cranked while the filter is dismantled.

1. Slacken the bleed screw at banjo fitting in the fuel filter head. Operate the lift pump by means of its priming lever and, when the fuel flowing from the screw is free of air bubbles, tighten the screw.
2. Slacken the union nut at the injection pump end of the fuel feed pipe. Operate the lift pump, and when the fuel flowing from the union is free of air bubbles, tighten the nut.
3. Slacken the air bleed screw on the fuel pressure switch adapter. Operate the lift pump and when the fuel flowing from the bleed screw is free of air bubbles, tighten the screw.
4. Slacken the air bleed screw on the injection pump governor housing. Operate the lift pump until the fuel flowing from the bleed screw is free of air bubbles, leave the bleed screw slack.
5. Slacken the air bleed screw on the injection pump high-pressure banjo bolt. Operate the starter motor with full throttle in the full run position and when the fuel flowing from the high-pressure bleed screw is free of air bubbles, tighten the bleed screw.
6. Continue cranking the engine with the starter motor to expel any air trapped in the governor and when the fuel flowing from the governor housing bleed screw is free of air bubbles, tighten the bleed screw.
7. Slacken the union nut at the injector end of any two high-pressure pipes. Operate the starter motor with throttle in the full run position and when the fuel flowing from both pipes is free of air bubbles, tighten both union nuts.
8. Start the engine and allow it to run until it is firing on all cylinders or repeat step 7 if necessary.
9. **Note:**  
If difficulty in starting occurs, the sea water intake valve must be closed to prevent filling of the exhaust system with sea water. Immediately when the engine starts, open the sea water intake valve to prevent damage to the pump and engine.

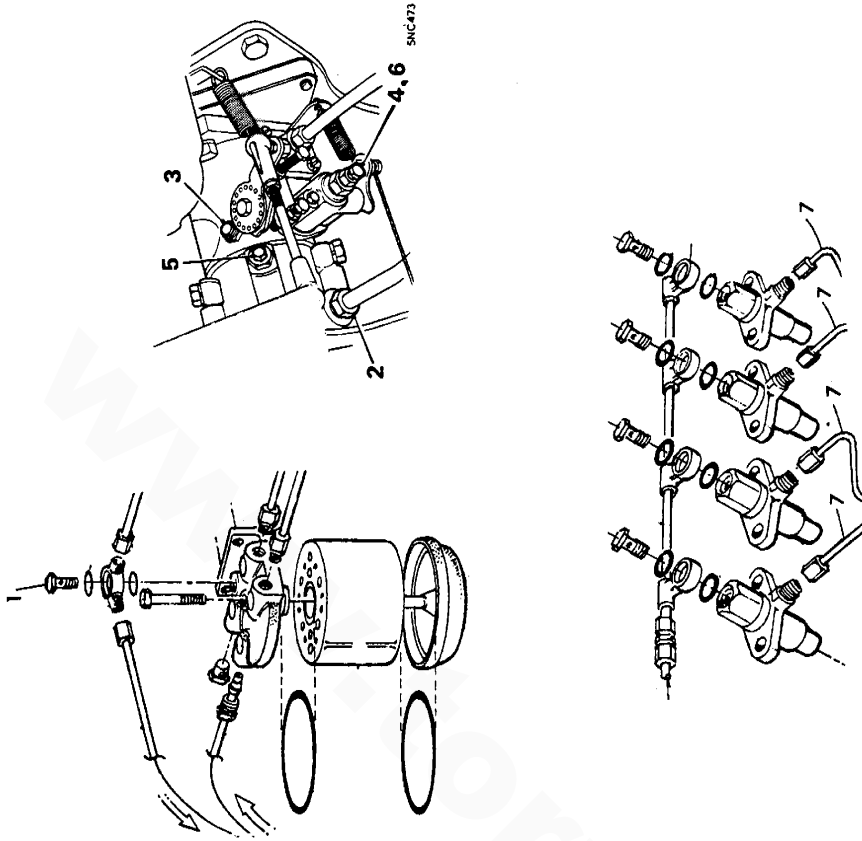

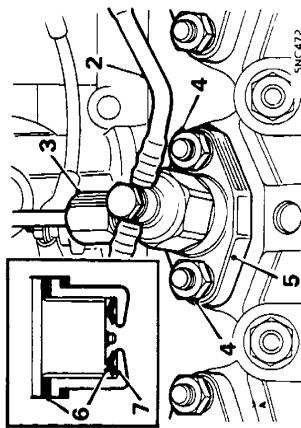

**INJECTORS**

**Remove and refit 19.60.01**

Service tools: 18G 284, 18G 284 P

**Removing**

- 1 Disconnect the spill rail from the injectors.
- 2 Disconnect the high-pressure pipes from the injectors.
- 3 Remove the nuts and washers securing the injectors.
- 4 Withdraw the injectors, using tools 18G 284 and 18G 284 P if necessary.
- 5 Remove the two sealing washers from each injector position.

**Refitting**

- 7 Fit two new sealing washers to each injector position, fitting the smaller washer as shown.
- 8 Reverse the procedure in 1 to 5, tightening the injector securing nuts to 12 lbf ft (1.7 kgf m, 16 Nm).
- 9 If more than two injectors have been removed, crank the engine with the starter motor and bleed at least two of the high-pressure pipes.

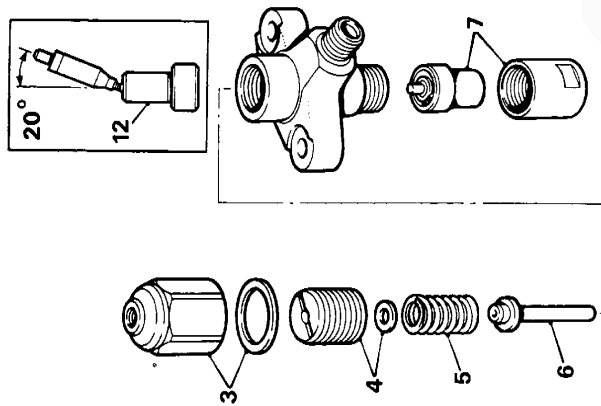

- 12 Renew the nozzle assembly if the pintle clearance allows an angle of more than 20° when checked as shown.
- 13 If necessary, restore the nozzle and valve seats to the angles given in DATA.
- 14 Check the needle lift against the figure in DATA.
- 15 Reverse the procedure in 2 to 7, tightening the nozzle nut to 50 lbf ft (6.9 kgf m, 68 Nm).
- 16 Test and set the injectors to the specification given in DATA, using tools 18G 109 A and 18G 109 B.
- 17 Fit the injectors, see 19.60.01.

**DATA**

Auxiliary hole diameter	0.2 mm
Needle lift	0.70 to 0.75 mm
Nozzle seat angle	59° 0'
Valve seat angle	60° 0'

**Testing**

TEST	NOZZLE SET TO OPEN AT	ADAPTOR (18G 109 B) SET TO OPEN AT	STROKES PER MINUTE	REQUIREMENTS
Spray	Auxiliary	220 Atm	60	Spray free of distortions. Slight core permissible.
	Main	220 Atm	140	Spray free of distortions. Slight core permissible.
Seat tightness	100 Atm	—	—	Dry nozzle after 10 seconds at 90 Atm pressure
Back-leakage	160 to 170 Atm	—	—	Initial pressure 160 Atm. Time for pressure drop from 150 to 100 Atm to be between 6 and 140 seconds
Final setting	135 Atm*	—	—	—

\* Add 5 Atm when setting new injectors or after fitting new springs.

**INJECTORS**

**Overhaul 19.60.08**

Service tools: 18G 109 A, 18G 109 B, 18G 109 E, 18G 210, 18G 388, 18G 487

- 1 Remove the injectors, see 19.60.01.
- 2 Mount the injector in tool 18G 388.
- 3 Remove the cap nut and sealing washer.
- 4 Remove the spring cap and shim.
- 5 Remove the spring.
- 6 Lift out the spindle.
- 7 Remove the nozzle nut and nozzle, using tool 18G 210.
- 8 Renew the spring if it shows any sign of weakness or distortion.
- 9 Renew the spindle if it is not perfectly straight.
- 10 Clean the nozzle and valve, using kit 18G 487.
- 11 Reverse-flush the nozzle, using tools 18G 109 A and 18G 109 E.



**SERVICE TOOLS**

All Service Tools mentioned in this Manual must be obtained direct from the tool manufacturers:

Messrs V L Churchill & Co. Ltd.  
 PO Box No. 3  
 London Road  
 Daventry  
 Northants NN11 4NF  
 England

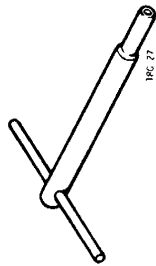

18G 27 Valve Seat Cutter and Pilot Handle



18G 29 Valve Grinding-in Tool

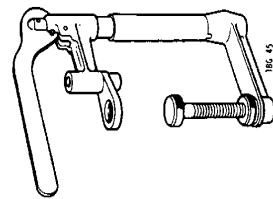

18G 45 Valve Spring Compressor

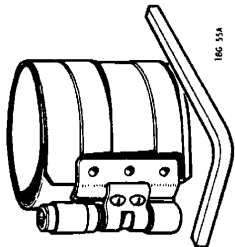

18G 55A Piston Ring Compressor

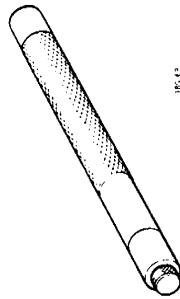

18G 69 Oil Pump Release Valve Grinding-in Tool

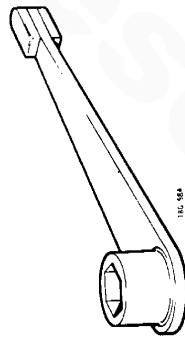

18G 98 A Starting Nut Handle

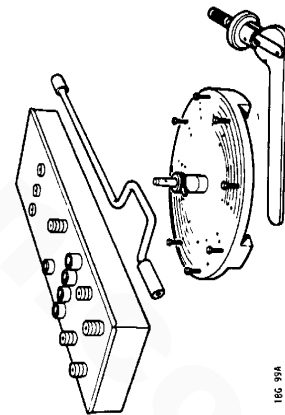

18G 99 A Clutch Assembly Gauging Fixture

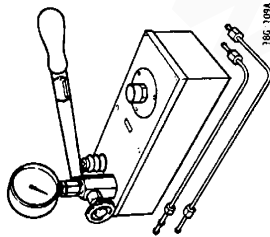

18G 109 A Injector Nozzle Testing Machine

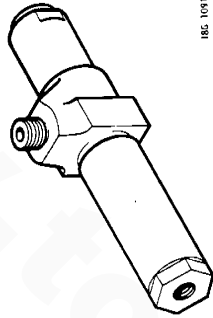

18G 109 B Injector Nozzle Testing Adaptor



18G 109 E Injector Nozzle Reverse Flush Adaptor

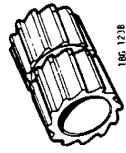

18G 123 B Camshaft Liner Reamer Cutter

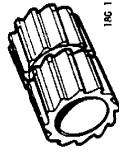

18G 123 E Camshaft Liner Reamer Cutter

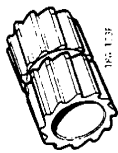

18G 123 F Camshaft Liner Reamer Cutter

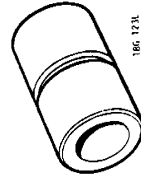

18G 123 L Camshaft Liner Reamer Pilot

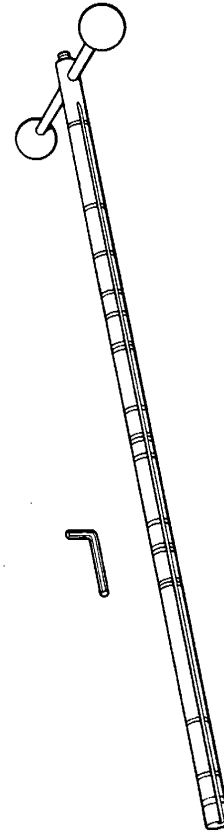

18G 123 A Camshaft Liner Reamer Basic Tool



18G 123 T Camshaft Liner Reamer Pilot

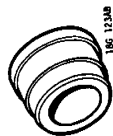

18G 123 AB Camshaft Liner Reamer Pilot

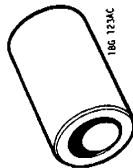

18G 123 AC Camshaft Liner Reamer Pilot



18G 123 AD Camshaft Liner Reamer Pilot



18G 124 A Camshaft Liner Reamer/Replacer - Basic Tool



18G 124 B Camshaft Liner Remover/Replacer - Adaptor



18G 124 C Camshaft Liner Remover/Replacer - Adaptor

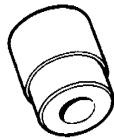

18G 124 F Camshaft Liner Remover/Replacer - Adaptor

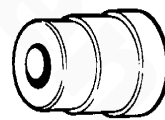

18G 124 H Camshaft Liner Remover/Replacer - Adaptor

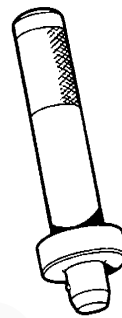

18G 134 Bearings and Oil Seal Replacer - Basic Tool

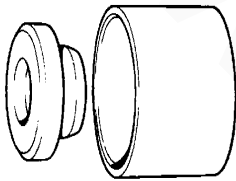

18G 134 BD Timing Case Oil Seal Replacer - Adaptor

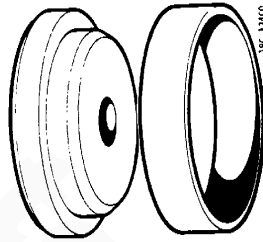

18G 134 CQ Crankshaft Rear Oil Seal Replacer - Adaptor

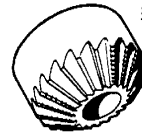

18G 167 Valve Seat Finishing Cutter



18G 167 B Valve Seat Narrowing Cutter - Top

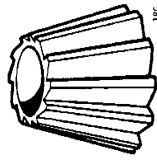

18G 167 C Valve Seat Narrowing Cutter - Bottom

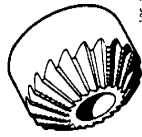

18G 174 Valve Seat Finishing Cutter

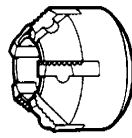

18G 174 A Valve Seat Glaze Breaker

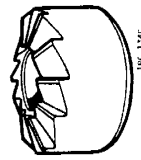

18G 174 B Valve Seat Narrowing Cutter - Top

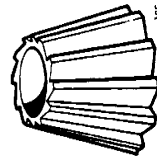

18G 174 C Valve Seat Narrowing Cutter - Bottom

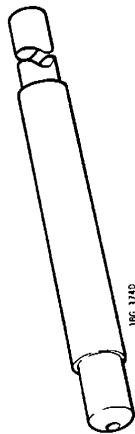

18G 174 D Valve Seat Cutter Pilot

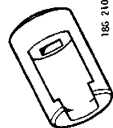

18G 210 Injector Nozzle Nut Spanner

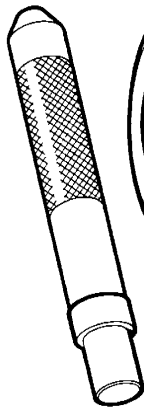

18G 226 Valve Rocker Bush Remover/Replacer

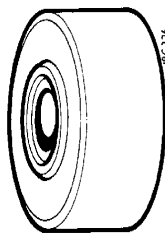

18G 226A Valve Rocker Bush

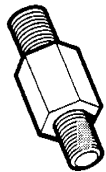

18G 284 A Main Bearing Cap Remover - Adaptor

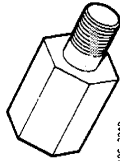

18G 284 P Injector Remover - Adaptor

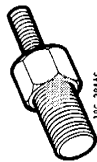

18G 284 AC Main Bearing Cap Remover - Adaptor

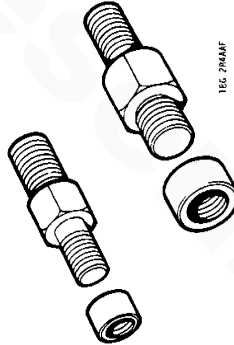

18G 284 AAF Crankshaft Spigot Bush Remover - Adaptor

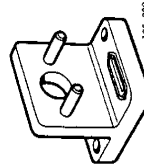

18G 388 Injector Dismantling Fixture

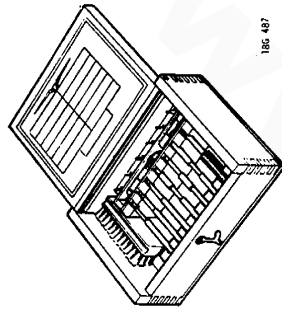

18G 487 Injector Nozzle Cleaning Kit

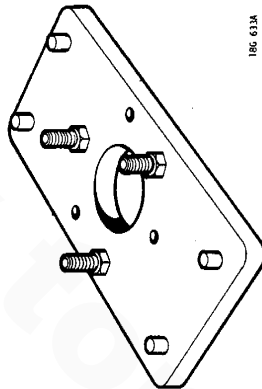

18G 633 A D.P.A. Assembly Base

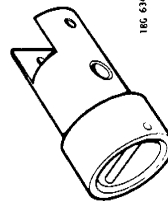

18G 634 Assembly Box Spanner



18G 635 Hydraulic Drive Shaft Protection Cap

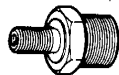

18G 636 Transfer Pressure - Adaptor



18G 637 Assembly Rod

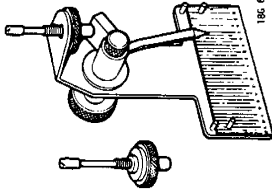

18G 638 B Automatic Advance Gauge

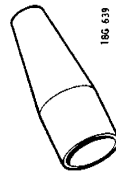

18G 639 Head Locating Fitting Protection Cap



18G 640 Automatic Advance Plug Protection Cap

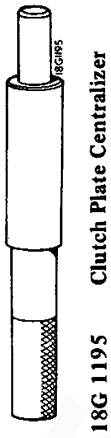

18G 1195 Clutch Plate Centralizer

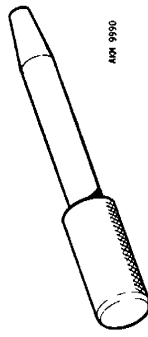

AKM 9990 Timing Pin

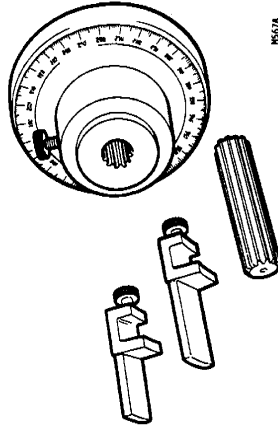

MS67A Injection Timing Gauge



18G 691 A Pilot Guide

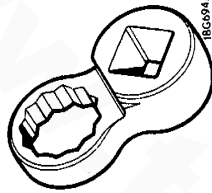

18G 694 A Cylinder Head Nut Crowfoot Wrench (Special) — Alternative Tool 18G 694



18G 1004 Circclip Pliers — Small

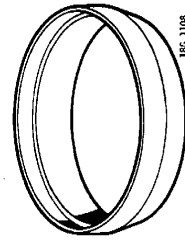

18G 1108 Crankshaft Rear Oil Seal Protector Sleeve

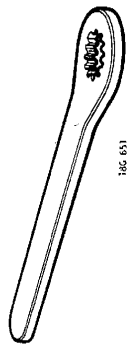

18G 651 Drive Shaft Holding Tool

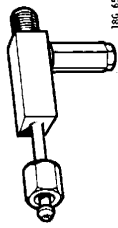

18G 653 A Relief Valve Timing Adaptor

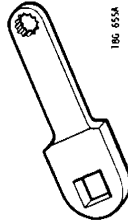

18G 655 A Drive Plate Screw Torque Adaptor



18G 656 Maximum Fuel Adjusting Probe

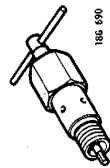

18G 690 End Plate Adjuster

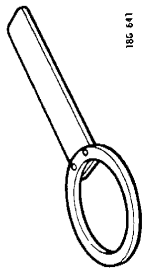

18G 641 Assembly Drive Plate Spanner

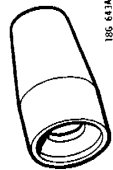

18G 643 A Metering Valve Pinion Protection Cap

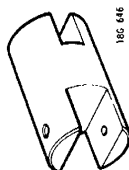

18G 646 Torque Spanner Socket

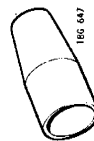

18G 647 Assembly Cap

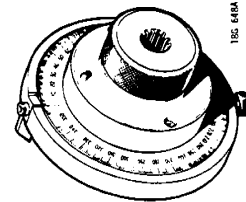

18G 648 A Universal Flange Marking Gauge

[www.torresen.com](http://www.torresen.com)

## OTHER OVERHAUL

CONTENTS	SECTION	PAGE
MARINE ENGINE ELECTRICAL SYSTEM.....	Q	
Activation by Keyswitch (1980 onwards).....		Q.2
Activation by Fuel Pressure.....		Q.4
Activation by Lube Oil Pressure.....		Q.6
COOLING SYSTEM (EXTERNAL).....	R	
TRANSMISSIONS.....	S	
Type SAO Manual.....		S.9
SA1 and SAO Clutch Adjustments.....		S.21
SA1 and SAO Reduction Units.....		S.23
Paragon P-21 Series, Hydraulic.....		S.29
Warner Hydraulic.....		S.35
Short Profile Sailing Gear.....		S.41

## SECTION Q

# MARINE ENGINE ELECTRICAL SYSTEM

### ACTIVATION BY KEY SWITCH

This system is supplied on most Westerbeke engines beginning May, 1980. Essentially activation of the circuit is accomplished by the ignition position of the key switch. No oil pressure switch is required. The engine is preheated by depressing the preheat push button. The engine is cranked by turning the key switch to the right-most momentary position.

Voltage is maintained to the instruments, fuel solenoid or fuel lift pump if supplied, and to other electrical devices via the ignition position of the key switch.

Models which have a fuel solenoid or electric fuel pump may be turned off via the key switch. Models with mechanical fuel lift pumps or no fuel solenoid are stopped by pulling a stop cable.

The circuit is protected by a circuit breaker located near the starter. Any time excessive current flows, the circuit breaker will trip. This is a manually resettable breaker, and must be reset before the engine will operate electrically again.

CAUTION - the builder/owner must ensure that the instrument panel, wiring and engine are installed so that electrical devices cannot come in contact with seawater.

The latest information regarding your engine's electrical system is included on the wiring diagram shipped with the engine. Be sure to study this wiring diagram and all the notes thereon.

ACTIVATION BY KEYSWITCH

SECTION Q

SCHEMATIC DIAGRAM.

WIRING DIAGRAM.

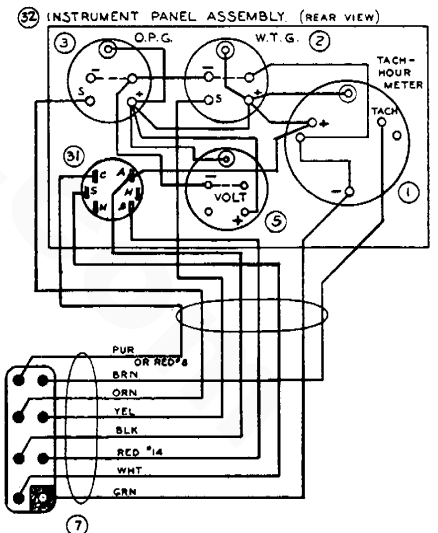
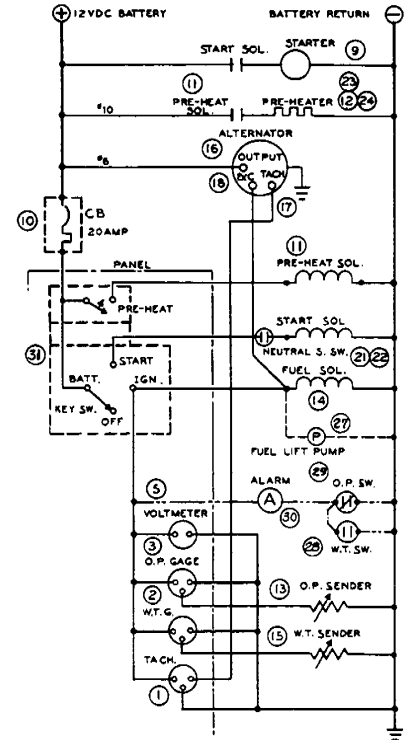
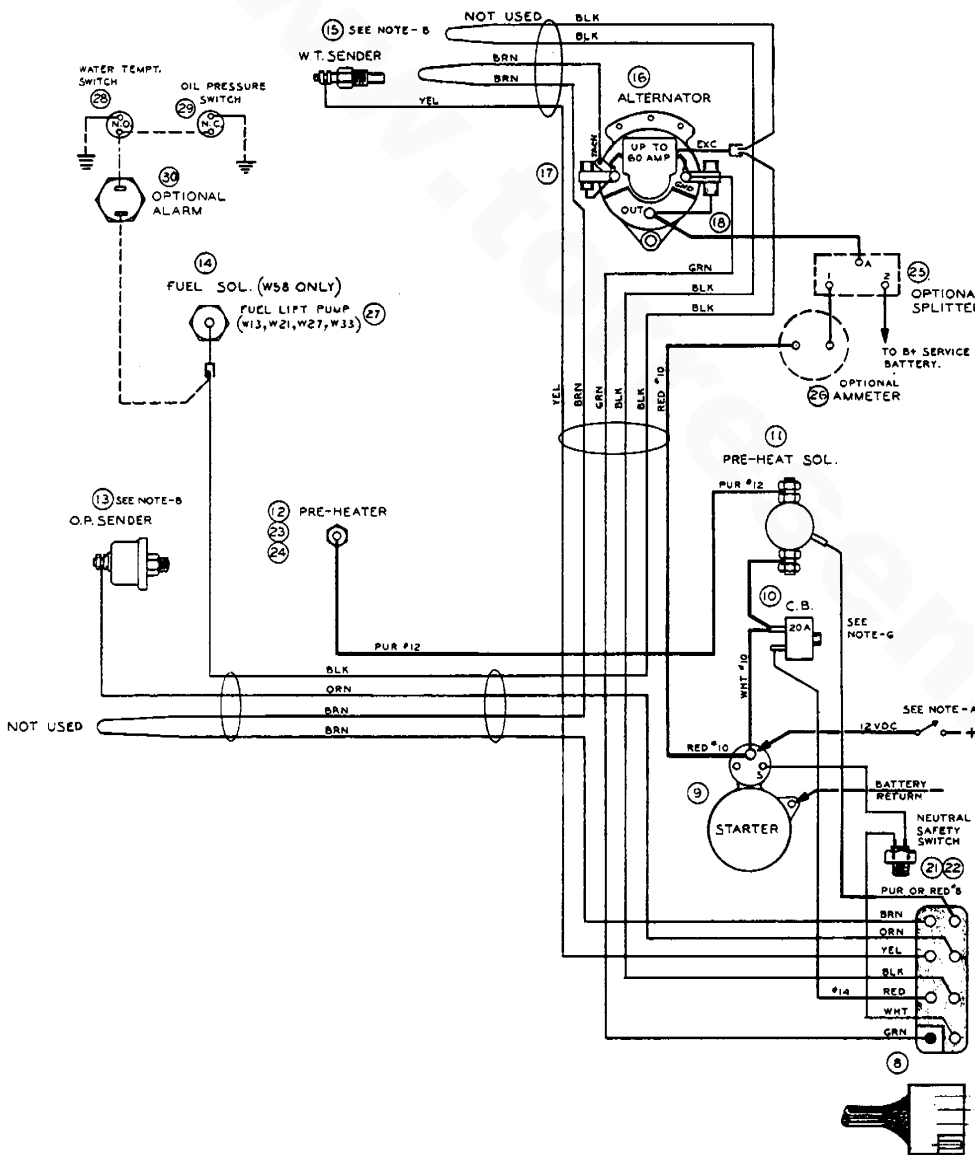



## MARINE ENGINE ELECTRICAL SYSTEM

### ACTIVATION BY FUEL PRESSURE (Push Button Start)

This system is supplied on all four and six cylinder Westerbeke engines beginning January 1975. Basically, the system is very simple and eliminates the need for a separate switch position to activate the engine alarm system, when supplied.

Starting is accomplished by operation of the start push button which causes the starting motor to crank.

Once the engine is running, fuel pressure developed in the low pressure side of the fuel injection pump operates a fuel pressure switch. Voltage is then applied to the alarm system (if supplied) and to the alternator for excitation and for all instruments.

When the engine is stopped, fuel pressure drops and the fuel pressure switch removes voltage from these devices.

When an engine is supplied with a pre-heating device, the device is energized by a separate push button.

NOTE: It is important that your engine installation includes fuses or circuit breakers, as described under "Ownership Responsibility" on the wiring diagram supplied with your engine.

**ACTIVATION BY FUEL PRESSURE  
(PUSH BUTTON START)**

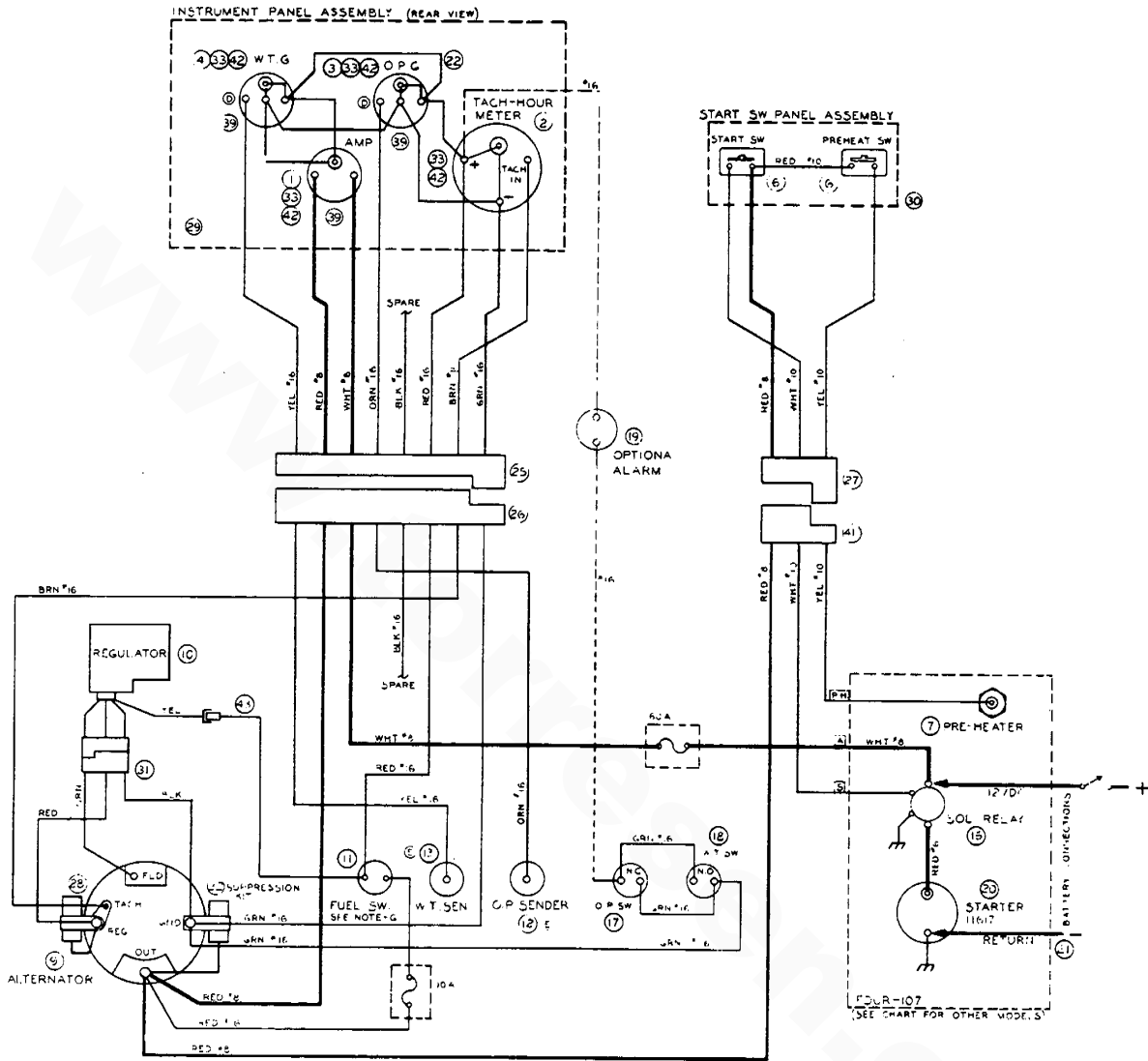
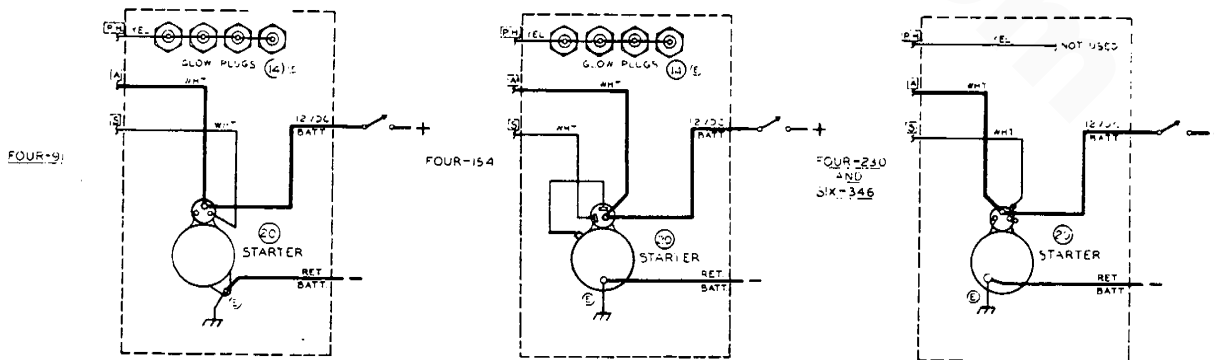

CHART FOR STARTER MOTORS AND HEATERS



Drawing No. 19201

## Marine Engine Electrical System

### ACTIVATION BY LUBE OIL PRESSURE (Keyswitch Start)

This system is supplied on all 4 and 6 cylinder Westerbeke diesels produced prior to January 1975. Operation is very simple. Putting the start switch in the Run position energizes an alarm system (when supplied). Returning the start switch to Off position de-energizes the alarm.

Turning the start switch to Crank position operates the starting motor and starts the engine. Upon starting, the start switch is released to the Run position.

When the engine develops oil pressure, voltage is supplied to the alternator for excitation and to all instruments. Whenever the engine stops, loss of oil pressure removes voltage from these devices.

When an engine is furnished with a pre-heating device, it is energized by a separate push button at the key switch panel.

When an engine is furnished with an electric stop solenoid, it is energized by a separate push button at the key switch panel.

NOTE: It is important that your engine installation includes fuses or circuit breakers, as described under "Owner's Responsibility" on the wiring diagram supplied with your engine.

**ACTIVATION BY LUBE OIL PRESSURE  
(KEYSWITCH START)**

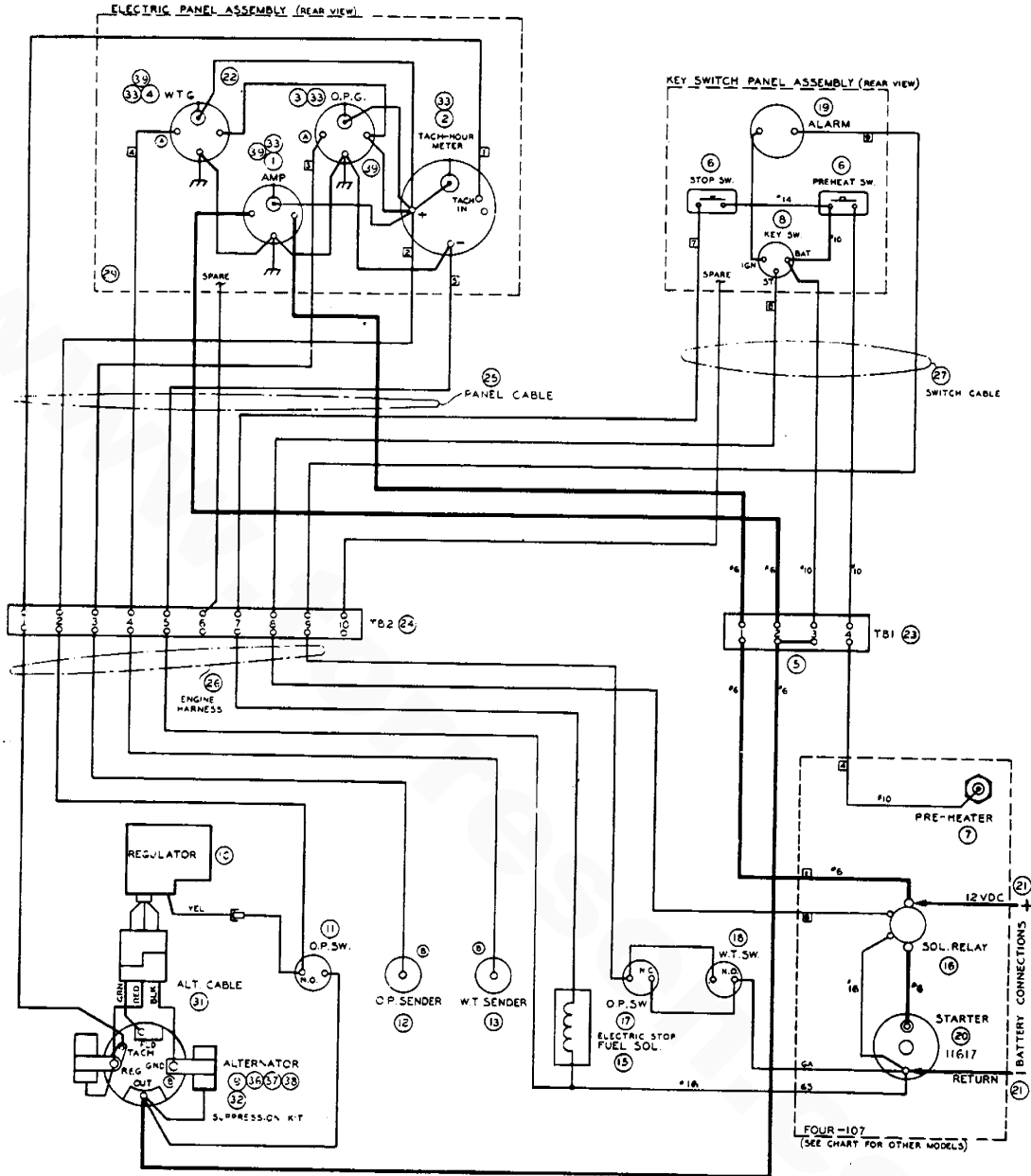

FOUR-60

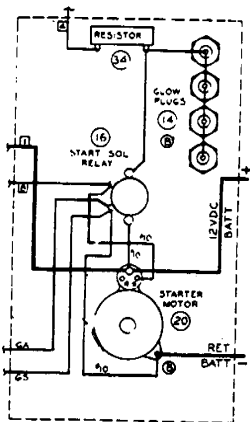

FOUR-91

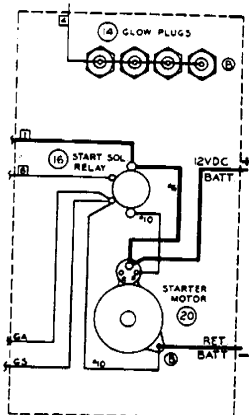

FOUR-154

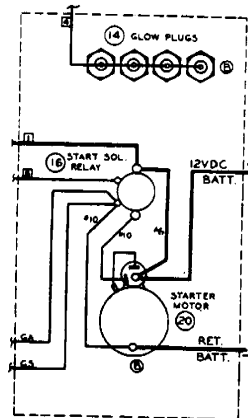

FOUR-230 & SIX-346

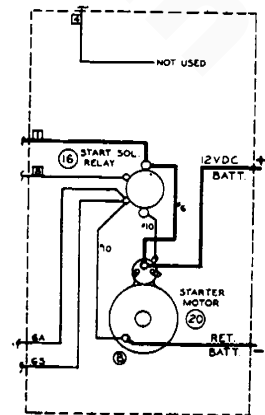

Drawing No. 15245

# YOUR NOTES

[www.torresen.com](http://www.torresen.com)

## **COOLING SYSTEM (EXTERNAL)**

### **1. DESCRIPTION:**

Westerbeke marine diesel engines are equipped with fresh water cooling. Transfer of heat from engine fresh water to sea water is accomplished in a heat exchanger, similar in function to an automotive radiator. Sea water flows through the tubes of the heat exchanger while fresh water flows around the tubes. The sea water and fresh water never mix with the result that the cooling water passages in the engine stay clean.

### **2. FRESH WATER CIRCUIT:**

Heat rejected during combustion, as well as heat developed by friction, is absorbed by the fresh water whose flow is created by a fresh water circulating pump. The fresh water flows from the engine through a fresh water cooled exhaust manifold, a heat exchanger, in most cases an oil cooler, and returns to the suction side of the fresh water circulating pump. The flow is not necessarily in this order in every model. When starting a cold engine, most of the external flow to the heat exchanger is prevented by the closed thermostat. Some amount of by-pass is maintained to prevent overheating in the exhaust manifold. As the engine warms up, the thermostat begins to open up allowing full flow of engine fresh water thru the external cooling system.

### **3. SEA WATER CIRCUIT:**

The sea water flow is created by a positive displacement neoprene impeller pump (gear pump in certain special cases). Normally the pump draws sea water directly from the ocean via the sea cock and sea water strainer. Sometimes a transmission oil cooler, or perhaps a V drive will be piped on the suction side of the sea water pump. Generally it is better to have as few devices on the suction side of the sea water pump as possible to preclude priming difficulties. Usually sea water flows directly from the dis-

charge of the sea water pump to the heat exchanger sea water inlet. After passing through the tubes of the heat exchanger, the sea water may enter a transmission oil cooler if present and if sea water cooled. Ultimately, the sea water enters a water injected, wet exhaust system, the most popular type of exhaust system in use. In the case of larger engines the sea water flow is divided prior to entering the exhaust systems so that a portion is dumped directly overboard and a portion is used to cool the exhaust system. Full sea water flow entering the exhaust system would create unnecessary exhaust back pressure.

### **4. SEA WATER PUMP:**

The sea water pump is self priming and positive displacement. It is a rotary pump with a nonferrous housing and a neoprene impeller. The impeller has flexible vanes which wipe against a curved cam plate within the impeller housing, producing the pumping action. On no account should this pump be run dry. There should always be a spare impeller and impeller cover gasket aboard.

### **5. SEA WATER PUMP IMPELLER REPLACEMENT:**

The following instructions are general and indicative only. Specific instructions where applicable may be packaged with your replacement impeller.

- a. Remove the front cover taking care to salvage the gasket.
- b. Remove the impeller by pulling straight outwards, parallel to the pump shaft. This is best done with a pair of pliers applied to the impeller hub.
- c. Coat the replacement impeller and the chamber into which it mounts with grease.
- d. Carefully align the impeller key way, or other locking mechanism,

R.2

with the shaft. Take care that all the impeller blades bend in the same direction and trailing.

- e. Inspect the front cover for wear. A worn front cover should ultimately be replaced. Sometimes it can be reversed as an emergency measure, but not when stamped markings would break the seal between the cover and the impeller blades.
- f. Reinstall the end cover with a new gasket.
- g. Be doubly sure to check quickly for sea water flow when starting the engine. The absence of flow indicates that the pump may not be priming itself properly. This situation must be investigated immediately or damage to the new impeller will result from overheating.

#### 6. ENGINE FRESH WATER:

It is preferable to fill your engine with a 50% antifreeze-water mixture. This precludes the necessity of draining coolant in the winter. Since most antifreezes contain preservative agents of one kind or another, rusting within the engine is minimized. Also the antifreeze mixture boils at a higher temperature than water, giving cooling system "head room."

When draining the engine, open the pressure cap first to relieve the vacuum created by draining.

#### 7. FILLING THE FRESH WATER SYSTEM:

It is very important to completely fill the fresh water system before starting the engine. It is normal for air to become trapped in various passages so all high points must be opened to atmosphere to bleed entrapped air. When an engine is started after filling with coolant, the system may look deceptively full until the thermostat opens. At this time when water flows through the external cooling circuit for the first time, pockets of air can be exposed and rise to the fill point. Be sure to add coolant at this time.

#### 8. THERMOSTAT:

Generally thermostats are of two types. One is simply a choking device which opens and closes as the engine temperature rises and falls. The second type has a by-pass mechanism. Usually this is a disc on the bottom of the thermostat which moves downward to close off an internal by-pass passage within the head. Both types of thermostats, from 1980 onward, have a 0.06" diameter hole punched through them to serve as a by-pass while the engine is warming up. This prevents overheating in the exhaust manifold during engine warm-up. The hole is critical and replacement thermostats must be equal in this design characteristic.

When replacing a thermostat, be sure that it is rotated so as to not strike the thermostat housing, projections inside the head, temperature senders or temperature switches which may be installed close to the thermostat.

A thermostat can be checked for proper operation by placing it in a pan of cold water and then raising the temperature of the water to a boil. The thermostat should open noticeably (with travel on the order of 1/4" - 1/2") and be fully opened when the water is boiling.

#### 9. ENGINE LUBE OIL COOLER:

Lubricating oil carries heat away from the engine bearings and other friction surfaces. The oil circulates from the lube oil pump, through the engine, through the engine oil cooler, and back to the oil pump.

The oil cooler may be cooled either by engine fresh water or by sea water.

#### 10. TRANSMISSION OIL COOLER:

Certain transmissions require oil cooling. In these cases, the transmission oil cooler is usually cooled by sea water.

Normally sea water enters this cooler after exiting the heat exchanger, but not always.

## TWO PASS MANIFOLD

Note: Drawing is indicative only. Specific models may vary in detail.

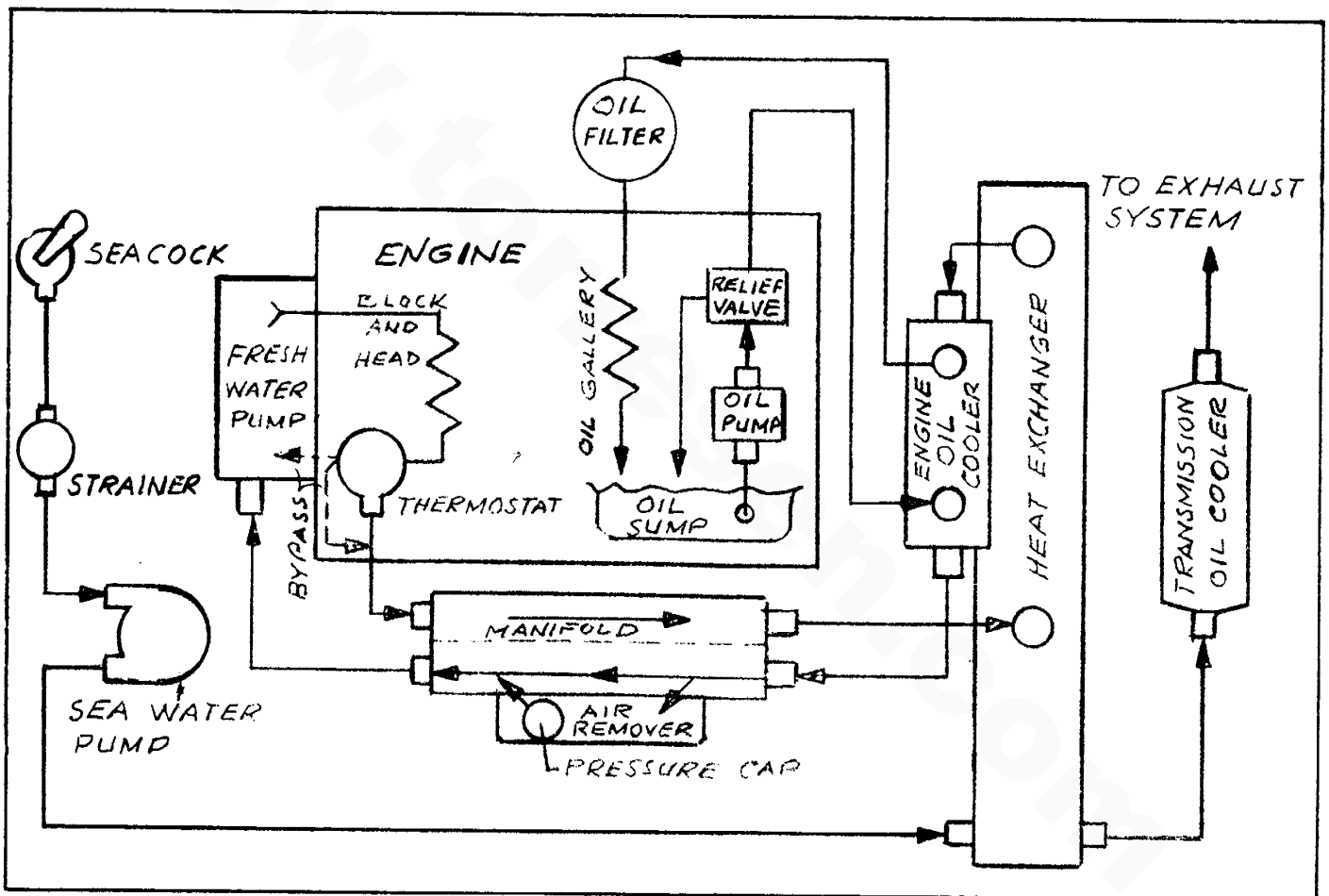



## SINGLE PASS MANIFOLD

Note: Drawing is indicative only. Specific models may vary in detail.

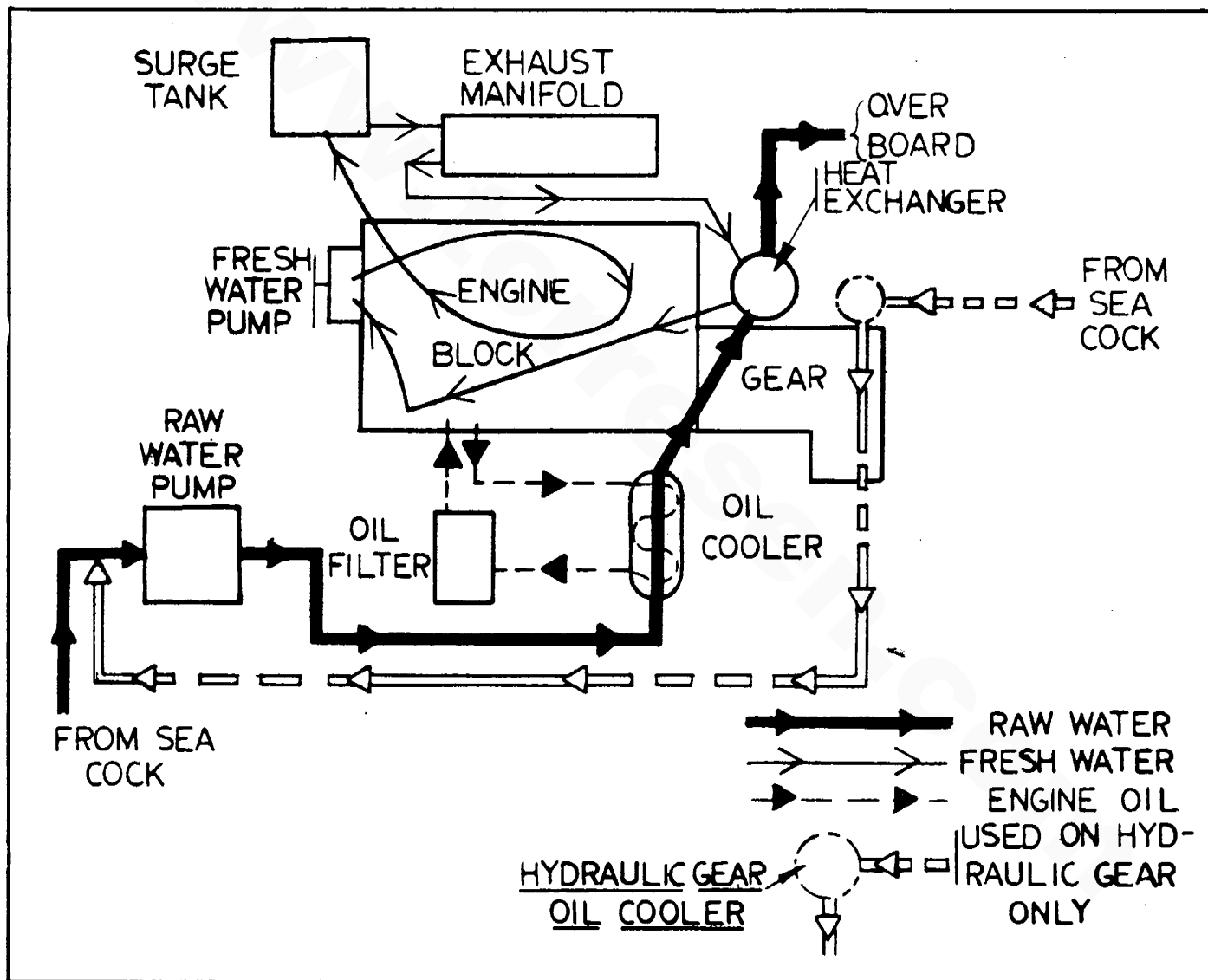

**TRANSMISSIONS**

[www.torresen.com](http://www.torresen.com)

## YOUR NOTES

[www.torresen.com](http://www.torresen.com)



## II. INTRODUCTION

Transmissions have been designed for smooth operation and dependability in marine use. The transmission is self-contained, having an oil pressure system and oil supply completely separated from engine lubricating oil systems.

Transmission oil under pressure is used to engage a forward or reverse drive. The for-

ward drive is through a multiple disc clutch arrangement, while the reverse drive utilizes a reverse clamp band and planetary gear train. The transmission oil is circulated and cooled through a separate external oil cooler core, which is in turn cooled by the engine water. Paragon transmissions are furnished with either direct drive or reduction gears. Gear reduction ratios and corresponding model identification numbers are listed in Section I, under "SPECIFICATIONS".

---

## III. INSTALLATION

A. The installation instructions below are for use when the original transmission has been removed for servicing and must be re-installed, or when the transmission unit is to be adapted as non-original equipment to a marine engine.

B. It is important that the engine and transmission rotations are matched. The direction of rotation of an engine is defined in this manual as the direction of rotation of the engine crankshaft as viewed from the output end of the transmission. A clockwise rotation of the engine is a right hand rotation and a counterclockwise rotation of the engine is a left hand rotation.

A letter "R" or "L" appearing on the transmission serial number plate illustrated in Section I, "SPECIFICATIONS", indicates whether the transmission is for use with a right or left hand rotating engine.

C. The hydraulic transmission is attached to the engine in the following manner:

1. Insert two 3-1/2" studs in opposite transmission mounting holes in the engine adapter plate.
2. Place the transmission against the studs so that the studs go through two of the matching holes in the transmission housing flange.
3. Slide the transmission along the studs toward the engine so that the spline on the shaft at the front of the transmission enters the matching splined hole in the engine vibration dampener.

4. Install and tighten four bolts with lockwashers through the transmission housing flange into the engine adapter plate. Remove the 3-1/2" studs. Install and tighten the two remaining bolts with lockwashers through the transmission housing flange.

D. The transmission and propeller shaft coupling must be carefully aligned before the propeller shaft is connected to the transmission, in order to avoid vibration and consequent damage to the transmission, engine, and boat hull during operation. To align the coupling, move the propeller shaft, with attached coupling flange, toward the transmission so that the faces of the propeller shaft coupling flange and transmission shaft coupling flange are in contact. The coupling flange faces should be in contact throughout their entire circumference. The total runout or gap between the faces should not exceed .002" at any point. If the runout exceeds .002", reposition the engine and attached transmission by loosening the engine support bolts and adding or removing shims to raise or lower either end of the engine. If necessary, move the engine sideways to adjust the runout or to align the coupling flange faces laterally. Tighten the engine support bolts and recheck the alignment of the coupling before bolting the coupling flanges together. Connect the coupling flanges with bolts, lockwashers, and nuts.

E. Connect the oil cooler lines to the transmission.

F. Connect the shift control cable from the cockpit control station to the transmission control valve lever, shown in Figure on page 5. Place the transmission control valve lever in the neutral position and

adjust the shaft control cable length until the cockpit control station hand lever is in the neutral position. Move the cockpit control hand lever to forward and reverse positions several times while observing the transmission control valve lever motion. The transmission control valve lever should move fully into forward or reverse position when the hand lever is moved into forward

or reverse position, and should return exactly to the neutral position when the hand lever is in the neutral position.

- G. Remove the oil dipstick, shown in Figure on page 5, and fill the transmission with Type A transmission fluid to the mark on the dipstick. Replace the dipstick in the transmission housing.

## IV. OPERATION

### Principle of Operation

The transmission forward and reverse drives are operated by transmission oil under pressure. An internal gear type oil pump delivers the transmission oil, under pressure, to the external oil cooler. The transmission oil is returned, still under pressure, to the oil distribution tube and relief valve. The relief valve maintains the oil pressure by remaining closed until the oil pressure reaches 60 PSI. When the control lever is shifted to the forward position, oil under pressure is delivered to the multiple disc clutch piston, which moves to clamp the clutch discs and planetary reverse gear case together. The discs and case then revolve as a solid coupling in the direction of engine rotation. The reverse drive is engaged by shifting the control lever to the reverse position, so that oil under pressure is delivered to the reverse piston. The reverse piston moves to clamp the reverse band around the planetary gear case, preventing the planetary gear case from moving but allowing the planetary gears to revolve to drive the output or propeller shaft in a direction opposite to the rotation of the engine. With the control lever in the neutral position, pressurized oil is prevented from entering the clutch piston or reverse band piston and the propeller shaft remains stationary.

### Starting Procedure

1. Always start the engine with the transmission in NEUTRAL to avoid moving the boat suddenly forward or back.
2. When the engine is first started, allow it to idle for a few moments. Stop the engine and check the transmission oil level. Add oil if necessary to bring the oil level up to the mark on the transmission dipstick.

#### NOTE

ON SUBSEQUENT START-UPS, THE TRANSMISSION OIL LEVEL MAY BE CHECKED BEFORE RUNNING THE ENGINE, WHEN ENGINE OIL IS CHECKED.

3. Start the engine again, with the transmission in NEUTRAL, and allow the engine to warm up to operating temperature.
4. Shift the transmission into FORWARD or REVERSE as desired. If the engine should stall when the transmission is shifted to FORWARD or REVERSE, place the transmission in NEUTRAL before restarting the engine.

It is recommended that shifting be done at speeds below 1000 RPM, and preferably in the 800 RPM, or idle engine range, to prolong the life of the engine, transmission, and boat. EMERGENCY shifts may be at higher engine speeds, but this is not a recommended practice.

## V. MAINTENANCE

### A. Lubrication

The Models P200, P300 and P400 transmissions are self-contained units, independent of the engine lubricating systems. The units are lubricated by pressure and by splash from its own oil. The type of oil recommended is "Transmission Fluid, Type A", commonly used for automatic transmissions in automobiles.

The quantity of oil depends upon the angle of installation, as well as the reduction model. The level must be maintained at the mark on the dipstick and should be checked periodically to ensure satisfactory operation.

When filling for the first time or refilling after an oil change, check the level after running for a few minutes to make certain that the oil cooler and the various passages

are full. If necessary, refill to the mark on the dipstick to ensure proper operation of the transmission. The transmission oil level should be checked each time the engine oil level is checked, before running the engine.

The oil in the transmission should be changed every 100 hours, or each season under normal conditions. However, the number of hours that can be run between oil changes varies with the operating conditions. Drain plugs are located at the bottom of the reverse gear housing and the reduction gear housing.

### B. Adjustments

No adjustment is necessary for the FORWARD drive multiple disc clutches, and the reverse band is self adjusting to compensate for lining wear, so that no external reverse band adjustment is necessary.

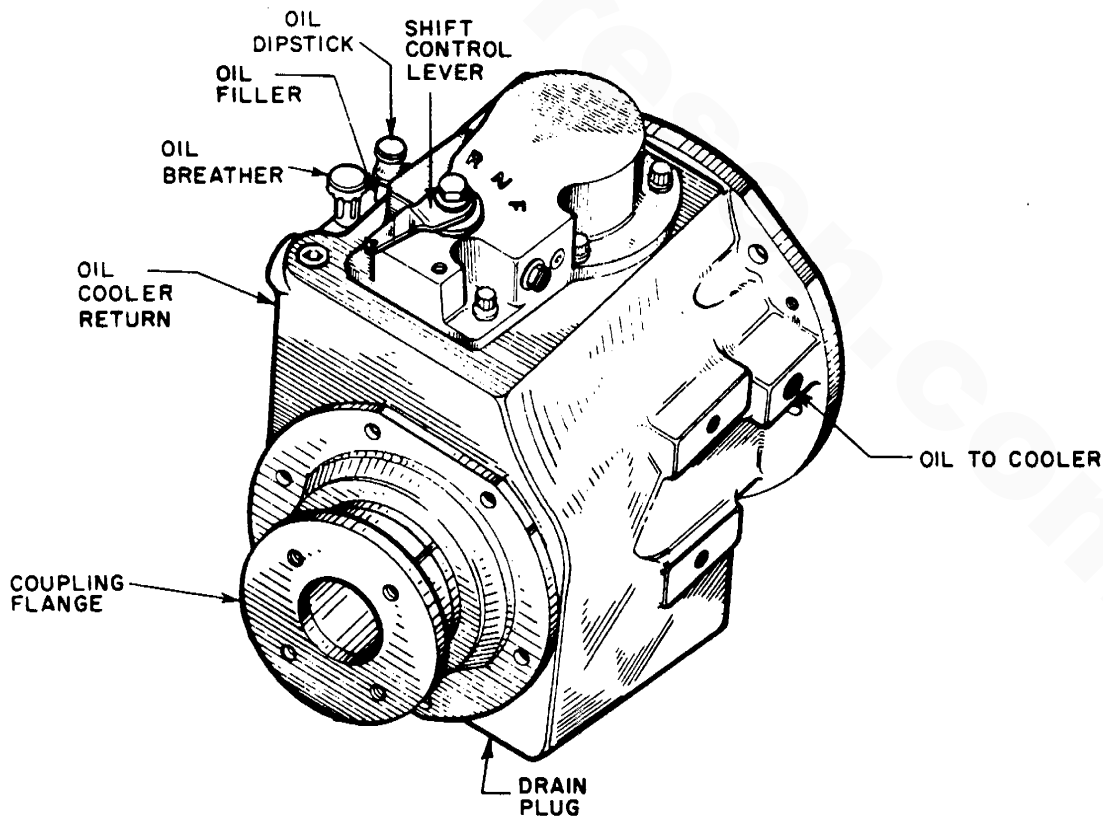

PROBLEM	POSSIBLE CAUSES AND METHODS OF CORRECTION
<p><b>GEAR INOPERATIVE</b></p> <p>Drive Shaft does not operate with selector valve in forward or reverse.</p>	<ol style="list-style-type: none"> <li>1. <b>Low Oil Pressure.</b> <ol style="list-style-type: none"> <li>a. Low oil supply. Add oil, refer to lubrication.</li> <li>b. Faulty oil gauge. Replace gauge. Oil gauge slow to register, air or obstruction in oil gauge line. Clean and bleed oil gauge line.</li> <li>c. Plugged oil lines or passages. Clean lines or passages.</li> <li>d. Oil pressure relief valve scored and sticking. Remove relief valve. Clean valve and valve bore in control valve housing with crocus cloth to free valve, or replace.</li> <li>e. Defective pistons and oil distributor seal rings. Replace seal rings.</li> <li>f. Defective oil pump. Check for wear and replace if necessary.</li> </ol> </li> <li>2. <b>High Oil Temperature</b> <ol style="list-style-type: none"> <li>a. Low oil supply. Add oil, refer to lubrication.</li> <li>b. Low water level in cooling system. Add water, and check for leaks.</li> <li>c. Plugged raw water inlet screen. Clean screen.</li> <li>d. Collapsed or disintegrated water inlet hose. Replace hose.</li> <li>e. Air leak in cooling water suction line. Replace suction line.</li> <li>f. Raw water pump impeller worn or damaged. Replace impeller.</li> <li>g. Clogged or dirty oil cooler element. Remove and clean</li> </ol> </li> <li>3. <b>Reverse Band not engaging Planetary Gear Cage.</b> <ol style="list-style-type: none"> <li>a. Reverse band lining worn out. Replace lining.</li> <li>b. Defective reverse piston "O" ring. Replace "O" ring.</li> </ol> </li> <li>4. <b>Failure of Planetary Assembly.</b> Remove gear case assembly, and check for defective or damaged parts. Replace defective or damaged parts.</li> <li>5. <b>Failure of Reduction Gear.</b> Remove reduction gear assembly and check for defective or damaged parts. Replace defective or damaged parts.</li> </ol>



PROBLEM	POSSIBLE CAUSES AND METHODS OF CORRECTION
<p><b>GEAR DRAGGING</b></p> <p>Drive Shaft rotates either forward or reverse with Selector Valve in neutral position.</p>	<p>1. Defective forward Clutch Plates. Forward clutch plates warped and sticking. Remove clutch plates and replace.</p> <p>2. Defective forward Clutch Piston Release Spring. Forward clutch piston release spring broken or weak. Replace spring.</p> <p>3. Binding in Planetary Assembly.                     <ul style="list-style-type: none"> <li>a. Bearings and gears worn excessively in gear case. Replace necessary parts.</li> <li>b. Input shaft bearings worn excessively, causing misalignment of input shaft. Replace necessary parts.</li> </ul> </p>
<p><b>GEAR SLIPPING OR SLOW TO ENGAGE</b></p> <p>With Selector Valve in forward or reverse position.</p>	<p>1. Low Oil Pressure. See "Gear Inoperative" (1).</p> <p>2. Worn forward Clutch Plates. Remove forward clutch plates and check for wear excessively, replace clutch plates.</p> <p>3. Reverse Band not engaging Gear Case. See "Gear Inoperative", (3).</p>
<p><b>INTERNAL AND EXTERNAL LEAKS</b></p>	<p>1. Water in Lubricating Oil.                     <ul style="list-style-type: none"> <li>a. Hole in oil cooler element permitting water to seep into oil compartment. Replace oil cooler element.</li> <li>b. Oil cooler gaskets. Check gaskets and replace.</li> </ul> </p> <p>2. Excessive Oil in Engine Crankcase or Flywheel Housing. Defective front end plate oil seal. Replace oil seal.</p> <p>3. Oil on Exterior of Marine Gear.                     <ul style="list-style-type: none"> <li>a. Oil seeping from breather. Check for too high oil level.</li> <li>b. Defective rear end oil seal. Replace oil seal.</li> </ul> </p> <p>4. Loss of Oil from Transmission.                     <ul style="list-style-type: none"> <li>a. Check for defective gaskets and seal.</li> </ul> </p>

## WARNER HYDRAULIC

### DESCRIPTION

Westerbeke Four-107 Engines are also furnished with Warner hydraulic direct drive and reduction gear assemblies.

The direct drive transmission consists of a planetary gear set, a forward clutch, a reverse clutch, an oil pump, and a pressure regulator and rotary control valve. All of these are contained in a cast iron housing along with necessary shafts and connectors, to provide forward, reverse and neutral operation. A direct drive ratio is used for all forward operation. In reverse, the speed of the output shaft is equal to input shaft speed, but in the opposite direction. Helical gearing is used to provide quieter operation than can be obtained with spur gearing.

Oil pressure is provided by the crescent type pump, the drive gear of which is keyed to the drive shaft and operates at transmission input speed to provide screened oil to the pressure regulator.

From the regulator valve the oil is directed through the proper circuits to the bushings and anti-friction bearings requiring lubrication. A flow of lubricant is present at the required parts whenever the front pump is turning and it should be noted that supply is positive in forward, neutral and reverse conditions.

The unit has seals to prevent escape of oil.

Both the input and output shafts are coaxial, with the input shaft splined for the installation of a drive damper, and the output shaft provided with a flange for connecting to the propeller shaft.

### CONTROL LEVER POSITION

The position of the control lever on transmission when in forward should

be shifted to the point where it covers the letter "F" on the case casting, and is located in its proper position by the poppet ball. The Warranty is cancelled if the shift lever poppet spring and/or ball is permanently removed, or if the control lever is changed in any manner, or repositioned, or if linkage between remote control and transmission shift lever does not have sufficient travel in both directions. This does not apply to transmissions equipped with Warner Gear electrical shift control.

### LUBRICATION

The properties of the oil used in the transmission are extremely important to the proper function of the hydraulic system. Therefore, it is extremely important that the recommended oil, automatic transmission fluid (ATF), Type "A" be used.

### PROCEDURE FOR FILLING TRANSMISSION WITH OIL

When filling the transmission, oil should be added until it reaches the full mark on the dipstick. The quantity of oil depends upon the angle of the installation. The unit should be turned over at engine idle speed for a short time in order to fill all circuits, including the cooler and cooler piping.

### PROCEDURE FOR CHECKING OIL LEVEL

The oil level should be checked immediately after shutting off engine and sufficient oil added to again bring the transmission oil level to the full mark on the dipstick assembly. The dipstick assembly need not be threaded into the case to determine the oil level. It need only be inserted into the case until the cap or plug rests on the surface surrounding the oil filler hole.

The transmission should be checked periodically to assure proper oil level, and oil should be added if necessary.

## CHANGING OIL

It is recommended that the transmission oil be changed once each season. After draining oil from the unit, the removable oil screen should be thoroughly cleaned before refilling the transmission with the recommended oil (ATF) Type "A".

## REDUCTION GEAR BOX

The reduction gear box operates in conjunction with the direct drive unit. The reduction gear box consists of a planetary gear set which reduces the input revolutions to a fixed ratio.

It is recommended that all installations using a reduction gear have a suitable locking device or brake to prevent rotation of the propeller shaft when the boat is not under direct propulsion. If the marine gear is not in operation and the forward motion of the boat causes the propeller shaft to rotate, lubricating oil will not be circulated through the gear because the oil pump is not in operation. Overheating and damage to the marine gear may result unless rotation of the propeller shaft is prevented.

Except in an emergency, shift from forward to reverse drive through neutral at engine speeds below 1000 rpm to prevent damage to the engine, or marine gear.

# SHORT PROFILE SAILING GEAR

## 1. Description

### 1.1 Brief description

The Short Profile Sailing Gears are equipped with a positively driven, mechanically operated helical gearing system. The servo-operated multiple-disc clutch requires only minimum effort for gear changing, making the transmission suitable for single-lever remote control via a rod linkage, Morse or Bowden cable.

The torque transmission capacity of the clutch is exactly rated, preventing shock loads from exceeding a predetermined value and thus ensuring maximum protection of the engine.

The transmission units are characterized by low weight and small overall dimensions. The gearbox castings are made of a high-strength, corrosion-resistant aluminum alloy, chromized for improved sea water resistance and optimum adhesion of paint.

The transmissions are immersion-lubricated. Maintenance is restricted to oil level checks (see "Maintenance").

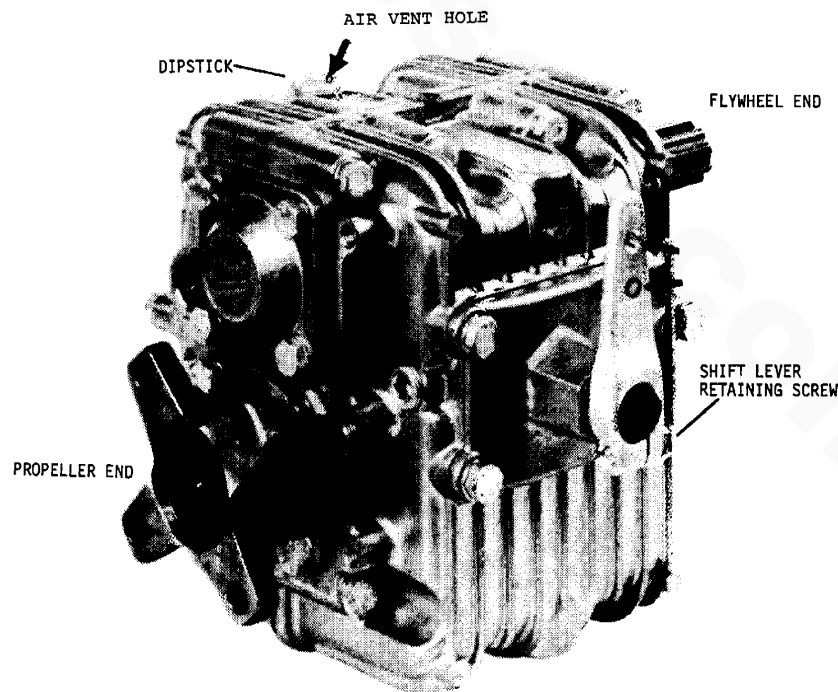

## 1.2 Gear casing

The rotating parts of the HBW transmission are accommodated in an oil-tight casing divided into two halves in the plane of the vertical axis. Ample dimensioned cooling ribs ensure good heat dissipation and mechanical rigidity.

An oil filler screw with dipstick and an oil drain plug are screwed into the gear casing. The filler screw is provided with a breather hole.

The shaft for actuating the multiple-disc clutch extends through a cover on the side of the gear casing.

## 1.3 Gear sets

The transmission is equipped with shaved, casehardened helical gears made of forged low-carbon alloy steel. The multi-spline driving shaft connecting the transmission with the engine is hardened as well.

The driven shaft (propeller side) of the transmission is fitted with a forged coupling flange.

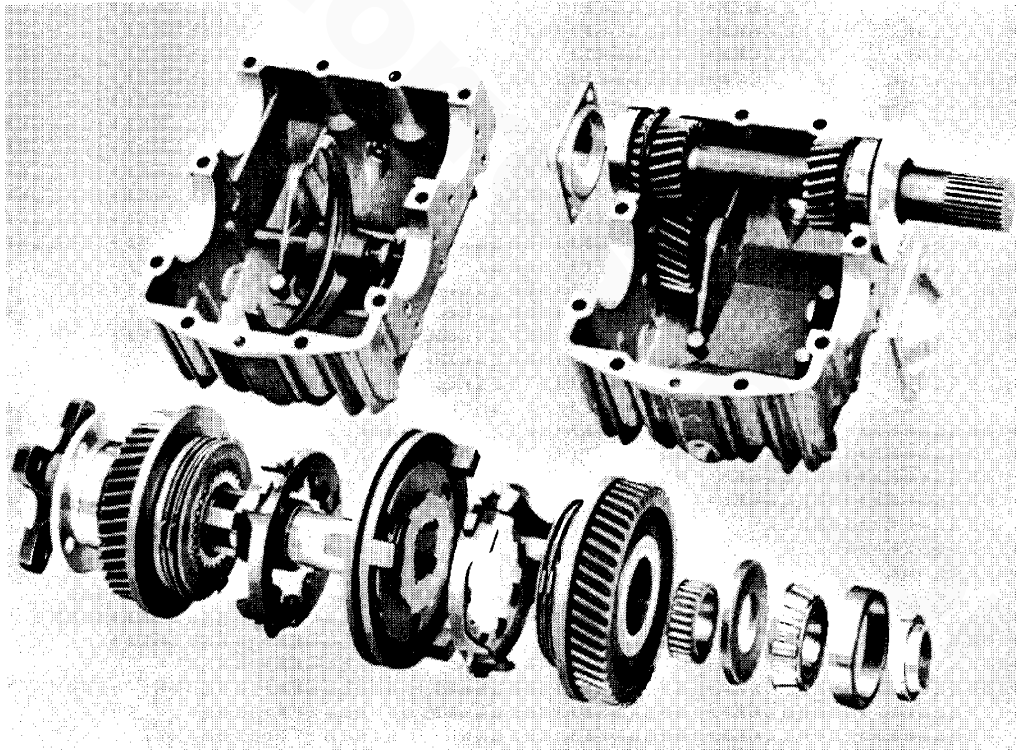

#### 1.4 Multiple-disc clutch including operation – power train

The engine torque is applied to the input shaft (36) in the specified direction of rotation and, in shifting position A (see item 1.2), via gear (44), the frictionally engaged clutch discs (51 and 52) to the external disc carrier (57) and from there via the guide sleeve (59) to the output shaft (66).

In shifting position B (see item 1.2), the torque is transmitted from the input shaft (36) via intermediate gear (26), gear (65), clutch discs (51 and 52) to the external disc carrier (57), the guide sleeve (59) and the output shaft (66).

##### – Function

The transmission uses a positively driven, mechanically operated multiple-disc clutch system mounted on the output shaft.

The thrust force required for obtaining positive frictional engagement between the clutch discs is provided by a servo system. This essentially comprises a number of balls which, by the rotary movement of the external disc carrier, are urged against inclined surfaces provided in pockets between the guide sleeve and the external disc carrier and in this manner exert axial pressure. The thrust force and, as a result, the transmittable friction torque are thus proportional to the input torque applied. Due to the cup springs (48) supporting the clutch disc stack and a limitation of the range of axial travel of the external disc carrier (57), the thrust force cannot exceed a predetermined value, so that the torque transmission capacity of the clutch is limited.

The actuating sleeve (60) is held in the middle position by spring-loaded pins. To initiate the shifting operation, the actuating sleeve (60) need merely be displaced axially by a shifting fork until the arresting force has been overcome. Then the actuating sleeve (60) is moved automatically by the spring-loaded pins, while the external disc carrier, which follows this movement, is rotated by the frictional forces exerted by the clutch discs, and the shifting operation is completed as described above.

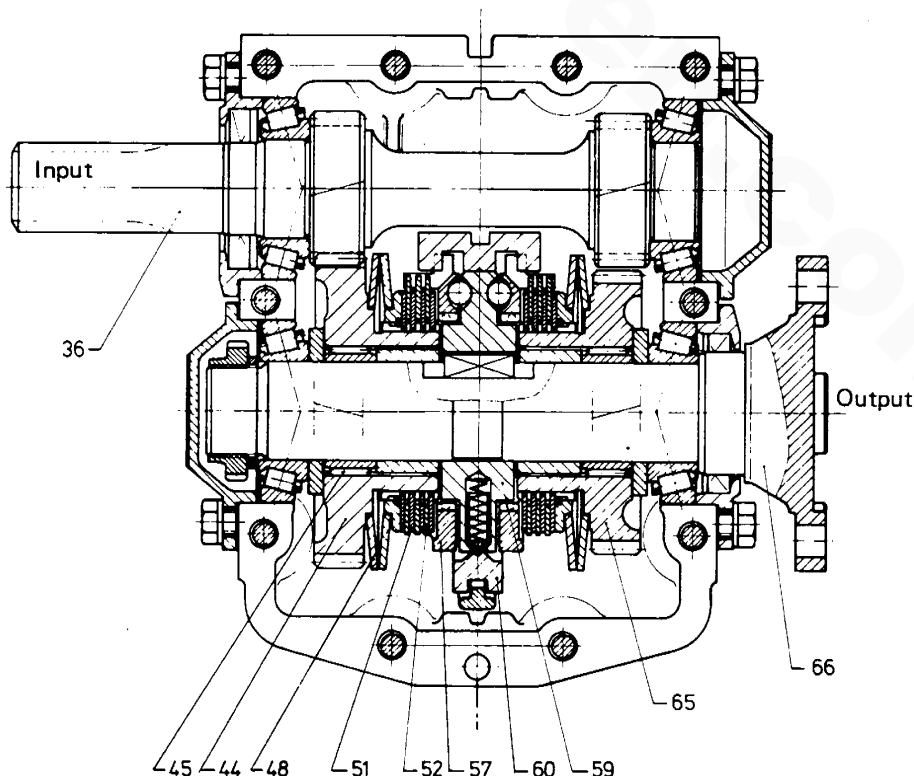

### 1.5 Shaft bearings

Both the input and the output shafts are carried in amply dimensioned taper roller bearings.

The intermediate gear and the movable gears are carried in sturdy needle roller bearings.

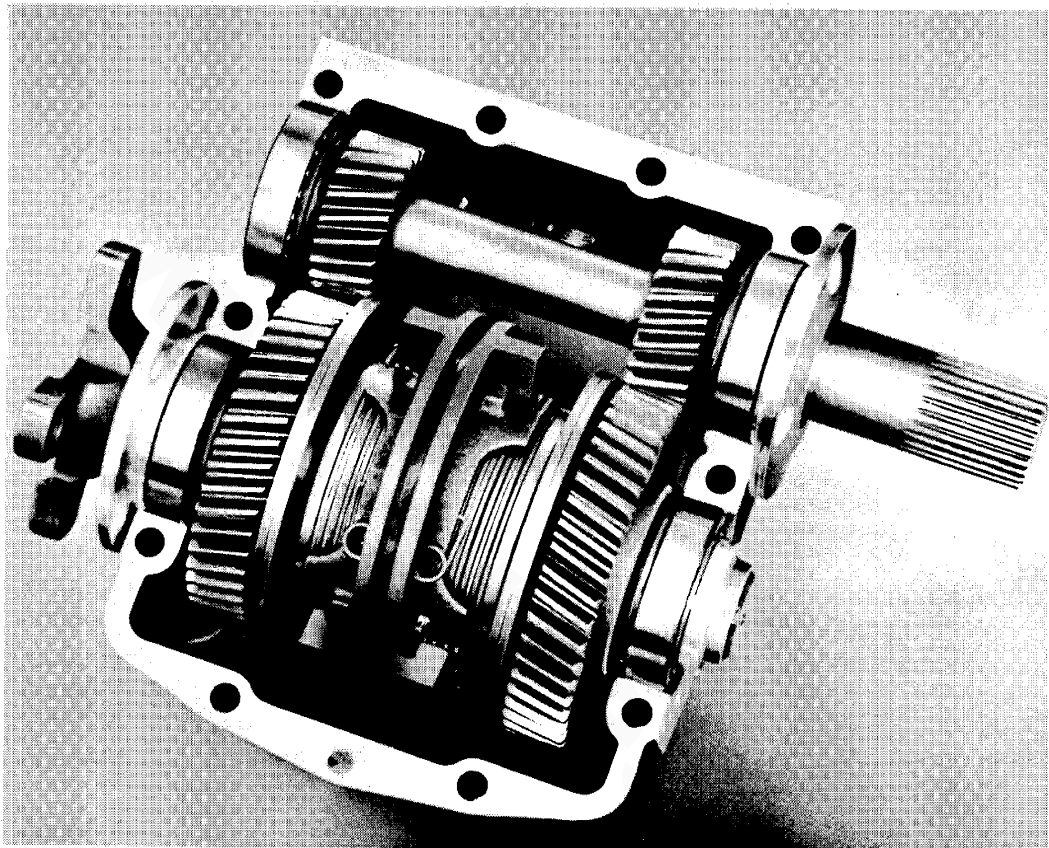

### 1.6 Shaft seals

External sealing of the input and output shafts is provided by radial sealing rings. The running surfaces on the shafts are casehardened.

### 1.7 Lubrication

The transmissions are immersion-lubricated. The bearings are generously supplied with splash oil and oil mist.

## **2. Installation**

### **2.1 Delivery condition**

For safety reasons, the gearbox is NOT filled with oil for shipment. The actuating lever is mounted on the actuating shaft.

Before leaving the factory, each transmission is subjected to a test run with the prescribed ATF oil. The residual oil remaining in the transmission after draining acts as a preservative and provides reliable protection against corrosion for at least 1 year if the units are properly stored.

### **2.2 Painting the gearbox**

Before painting the gearbox, take care to remove any oil films by means of suitable agents (e.g. HST safety cleansing fluid).

**Always cover the running surfaces and sealing lips of the radial sealing rings on both shafts before painting.** Make certain that the breather hole on the oil filler screw is not closed by the paint. Indicating plates should remain clearly legible.

### **2.3 Connection of gearbox with engine**

A torsio-elastic damping plate between the engine and the transmission is to compensate for minor alignment errors and to protect the input shaft from external forces and loads. Radial play should be at least 0.5mm.

### **2.4 Suspension of engine-gearbox assembly in the boat**

To protect the gearbox from detrimental stresses and loads, provision should be made for elastic suspension of the engine-gearbox assembly in the boat or craft.

The oil drain plug of the gearbox should be conveniently accessible.

### **2.5 Position of gearbox in the boat**

The inclination of the gearbox unit in the direction of the shafts should not permanently exceed an angle of 20 degrees (see illustration).

The gearbox can also be mounted with the output shaft in the **upward** position. Interchange the oil dipstick and the oil drain plug in this case.



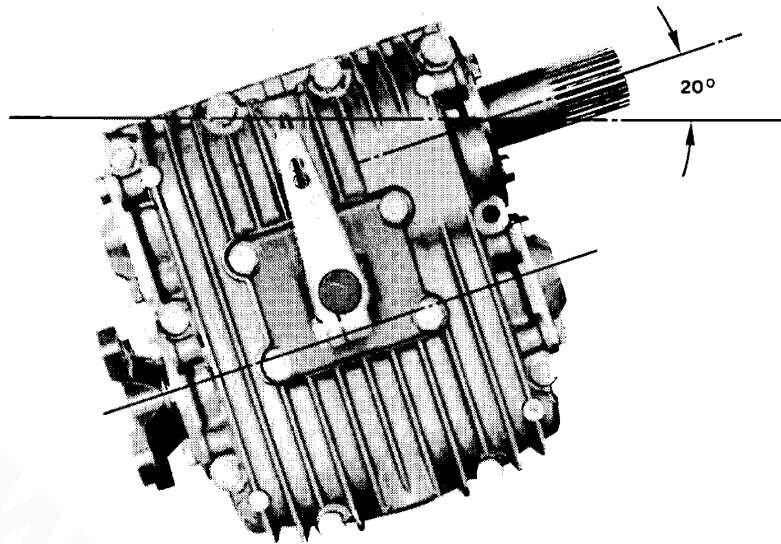

## 2.6 Operation of gearbox

Gear changing requires only minimum effort. The gearbox is suitable for single lever remote control. Upon loosening the retaining screw, the actuating lever (see illustration) can be moved to any position required for the control elements (cable or rod linkage). Make certain that the lever does not contact the actuating lever cover plate (9): the minimum distance between lever and cover should be 0.5 mm.

The control cable or rod should be arranged at right angles to the actuating lever in the neutral position of the lever.

The shifting travel, as measured at the pivot point of the actuating lever, between the neutral position and end positions A and B should be at least 35 mm for the outer and 30 mm for the inner pivot point.

A larger amount of lever travel is in no way detrimental.

However, if the lever travel is shorter, proper gear engagement might be impeded which, in turn, would mean premature wear, excessive heat generation and resulting damage.

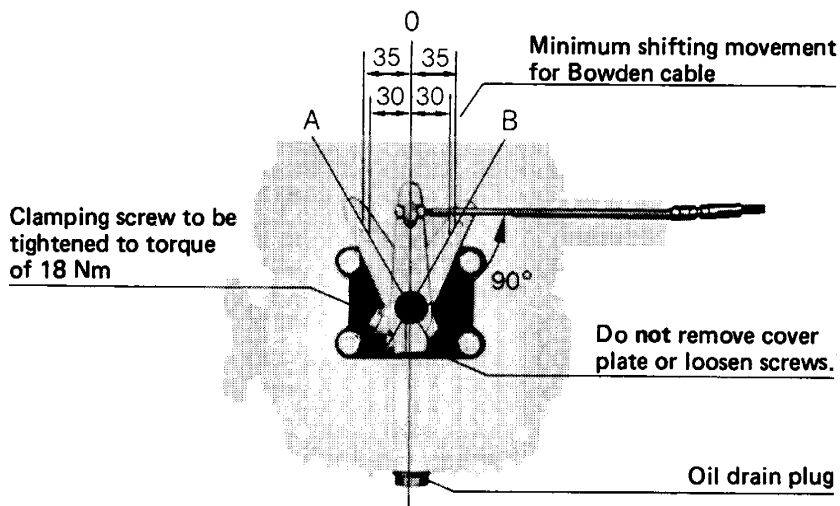

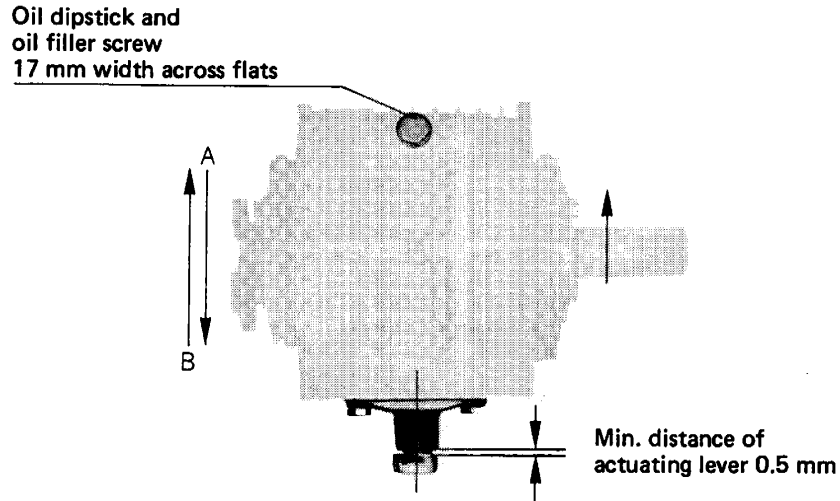

The position of the cover plate underneath the actuating lever is factory-adjusted to ensure equal lever travel from neutral position to A and B.

When installing the gearbox, make certain that shifting is not impeded e.g. by restricted movability of the Bowden cable or rod linkage, by unsuitably positioned guide sheaves, too small bending radius, etc.

## 2.7 Engine-gearbox compartment

Care should be taken that the engine-gearbox compartment is properly ventilated.

## 3. Operation

### 3.1 Initial operation

Fill the gearbox with oil of the recommended grade (see items 4.1 and 4.2). The oil level should be the index mark on the dipstick (see illustration).

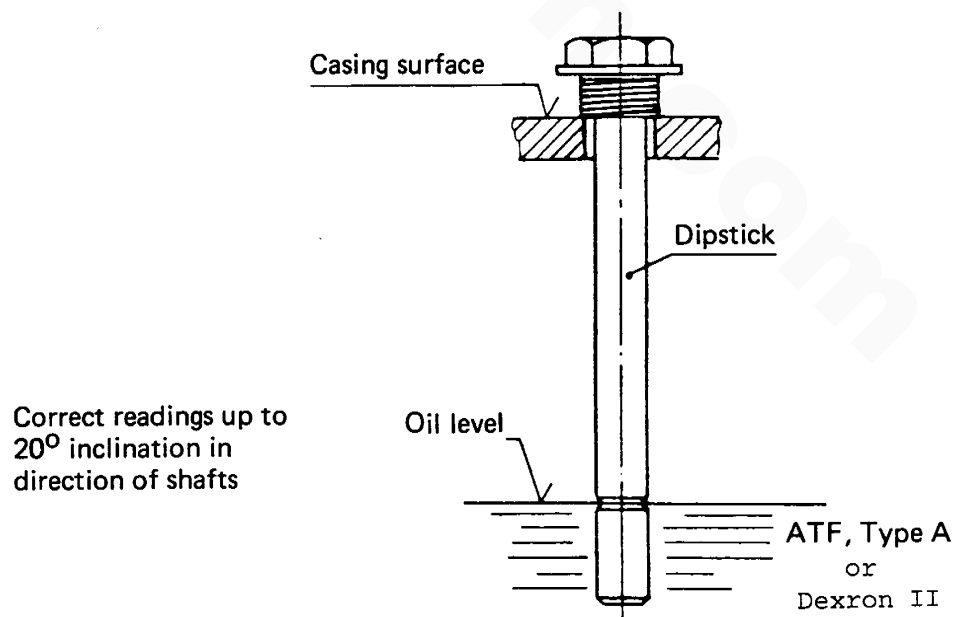

To check the oil level, just insert the dipstick, do **not** screw in. Retighten the hex screw with the dipstick after the oil level check.

### 3.2 Operating temperature

The max. permissible temperature of the transmission oil is 130 °C.

### 3.3 Operation of gearbox

Shifting is initiated by a cable or rod linkage via the actuating lever and an actuating cam. The completion of the gear changing operation is **automatic** and cannot be influenced by external control. The actuating lever is mounted on an actuating shaft and fixed by means of a retaining screw.

Gear changing should be smooth, not too slow, and continuous (without interruption). The multiple-disc clutch permits gear changing at high engine rpm, including sudden reversing at top speeds in the event of danger.

### 3.4 Operation without load

Rotation of the propeller without load, e.g. while the boat is sailing, being towed, or anchored in a river, as well as idling of the engine with the propeller stopped, will have no detrimental effects on the gearbox.

Locking of the propeller shaft by an additional brake is not required. since locking is possible by engaging the reverse gear.

### 3.5 Lay-up periods

If the transmission is not used for periods of more than 1 year it should be **completely** filled with oil of the same grade to prevent corrosion. Protect the input shaft and the output flange by means of an anticorrosive coating if required.

### 3.6 Preparation for re-use

Drain the transmission of all oil and refill to the proper level with the prescribed oil.

#### **4. Maintenance**

##### **4.1 Transmission oil**

To ensure trouble-free operation of the clutch, only use oil of the recommended type.

Under no circumstances should the oil contain any additives such as molybdenum sulphite.

We recommend commercial Automatic Transmission Fluid (ATF), Type A or Dexron II.

##### **4.2 Oil quantity**

HBW 5 approx 0.4 ltr

HBW 10 approx 0.6 ltr

HBW 20 approx 0.8 ltr

Use the index mark on the dipstick as a reference.

##### **4.3 Oil level checks**

Check the oil level in the transmission daily. Correct oil level is the index mark on the dipstick (see item 3.1). Always use the same oil grade when topping up.

##### **4.4 Oil change**

Change the oil for the first time after about 25 hours of operation, then at intervals of at least 1 year.

##### **4.5 Checking the Bowden cable or rod linkage**

The Bowden cable or rod linkage should be checked at shorter time intervals. The minimum lever travel from the neutral position to operating positions (O-A = O-B) should be 35 mm for the outer and 30 mm for the inner pivot point. Make certain that these minimum values are safely reached. Check the cable or rod linkage for easy movability (see item 2.9).

##### **4.6 OVERHAUL**

Disassembly of the transmission in the field is not recommended. If an overhaul or repair is needed, the work should be done by Westerbeke or an authorized Westerbeke service center.

[www.torresen.com](http://www.torresen.com)

## SECTION V

# SERVICE BULLETINS

The following Bulletins contain supplementary and updated information about various components and service procedures which are important to the proper functioning of your engine and its support systems.

You should familiarize yourself with the subjects and make sure that you consult the appropriate Bulletin(s) whenever your engine requires service or overhaul.

# SERVICE BULLETIN

**DATE:** 6/15/69

**BULLETIN NUMBER:** 20

**MODEL:** All Engines

**SUBJECT:** Connecting Pressure Sensing Devices to Oil Galleries

Oil pressure sensing devices, such as senders and switches, must never be connected directly to any oil gallery of an engine. The reason is simply that continued engine vibration causes fatigue of the fittings used to make such a connection. If these fittings fail, the engine loses its oil pressure and very quickly seizes.

Such pressure sensing devices must be bulkhead mounted and connected to the oil gallery using an appropriate grade of lubricating oil hose. Any fittings used to connect the hose to the gallery must be of steel or malleable iron. Brass must not be used for this purpose.



**J. H. WESTERBEKE CORP.**

AVON INDUSTRIAL PARK, AVON, MASS. 02322 · (617) 688-7700  
CABLE: WESTCORP, AVON · TELEX: 92-4444

# SERVICE BULLETIN

**DATE:** 5/6/74

**BULLETIN NUMBER:** 69

**MODEL:** All marine generators and marine engines

**SUBJECT:** Exhaust system failures

When engine sea water is fed into an exhaust system so that the full stream strikes a surface, erosion may cause premature failures.

Proper design of either a water jacketed or a water injected ("wet") exhaust system to prevent this problem requires that the sea water inlet be positioned so that the entering stream of sea water does not strike a surface directly. Also, the velocity of the entering sea water stream should be as low as possible which is achieved by having inlet fittings as big in diameter as possible.

In addition to the above design considerations, it is usually advantageous to divide the sea water flow at the point of entry to the exhaust system so that only a portion of it enters the exhaust system. The remainder is normally piped directly over the side. The proper proportion of the sea water flow to pass through the exhaust system can only be determined by trial and error. The goal is to prevent excessive exhaust temperatures with the least amount of sea water.



**J. H. WESTERBEKE CORP.**

AVON INDUSTRIAL PARK, AVON, MASS. 02322 · (617) 588-7700  
CABLE: WESTCORP, AVON · TELEX: 92-4444



# SERVICE BULLETIN

DATE: May 29, 1974

BULLETIN NUMBER: 72

MODEL: A11

SUBJECT: Non-Interchangeability between Manufacturers of Gauges and Senders

In recent years we have purchased gauges and senders from four different manufacturers.

In no case may the gauge of one manufacturer be used with the sender of another manufacturer. In some cases the wiring of either or both the gauge and the sender varies by manufacturer.

Thus it becomes important, when ordering a replacement gauge or ordering a replacement sender, to order a matched set or to know conclusively who the manufacturer is.

Ammeters are electrically interchangeable.

	<u>STEWART-WARNER</u> 2" DIA CASE	<u>VDO</u> 2 3/8" DIA CASE	<u>FARIA</u> 2" DIA CASE	<u>NOVOX</u> 2" DIA CASE
Ammeter	11581	11931	16550	19165
Oil pressure gauge	11544	11914	16548	19166
Oil pressure sender	11542	11916	16551	19167
Water temp. gauge	11545	11913	16549	19168
Water temp. sender	11543	11915	16552	19169

Adapter ring to install 2" dia gauge in 2 3/8" dia panel cut-out  
16023 and SB #44

Wiring diagram

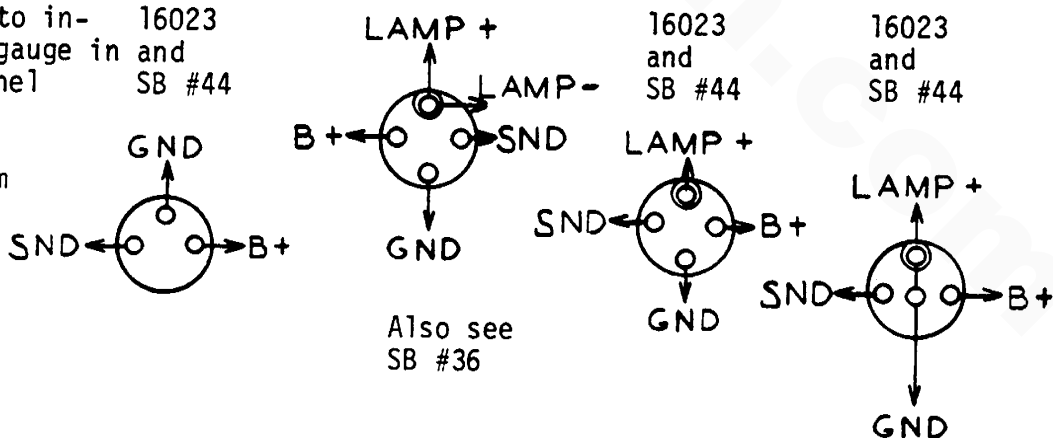

**J. H. WESTERBEKE CORP.**

AVON INDUSTRIAL PARK, AVON, MASS. 02322 · (617) 588-7700  
CABLE: WESTCORP, AVON · TELEX: 92-4444

# SERVICE BULLETIN

**DATE:** August 27, 1975

**BULLETIN NUMBER:** 76

**MODEL:** Four-91, W-30 ; W-50 (If fitted with this type pump)

**SUBJECT:** Proper bleeding procedure for hydraulically governed fuel injection pumps incorporating an engine anti-stall device

An anti-stall device is incorporated on fuel injection pumps fitted to the Four-91 engines. This device is located on top of the fuel pump governor housing, just beneath the air vent bleed screw. In fact, the bleed screw and anti-stall device are a complete assembly incorporating parts #1, #2, and #3 as shown on the diagram.

The anti-stall device has a spring loaded pin which comes in direct contact, with the top end of the fuel injection pump (metering valve) preventing rapid upward movement of the metering valve to the fuel cutoff position, during rapid engine deceleration. Rapid deceleration or rapid retarding of the throttle without this device installed would normally cause engine stalling and/or stoppage.

It should be noted here that under normal bleeding procedures, it is only necessary to bleed the bleed screw #5 shown on the diagram.

However, if excessive air entering the injection pump makes it necessary to bleed screw #1 in the diagram during the fuel pump bleeding procedure, when loosening or tightening the bleed screw #1, two wrenches should be used. One is to loosen the bleed screw and one is to hold the anti-stall device body #2 to prevent it from turning and upsetting the adjustments. If during the bleeding procedure screw #2 shown in the diagram is inadvertently turned in or clockwise during bleeding the result will be excessive engine RPM which cannot be controlled by retarding the throttle.

If the adjustment of the anti-stall device has been disturbed or when installing a replacement pump, the procedure for resetting it is as follows:

1. Loosen the locknut (#3) sufficiently to enable the anti-stall device body (#2) to be unscrewed two complete turns.
2. Set engine idle speed with idling stop screw (#4) to 800 RPM.
3. Turn the anti-stall device body (#2) clockwise until there is a barely perceptible increase in the idling speed. Now hold device body (#2) with wrench and tighten locknut (#3).
4. Accelerate the engine to maximum no load RPM and return the throttle rapidly to the idling position. Should the period of return from maximum RPM to idling RPM speed exceed three seconds, this is an indication that the device has been screwed in too far. However, should engine stalling occur, this is an indication that the device



**J. H. WESTERBEKE CORP.**

AVON INDUSTRIAL PARK, AVON, MASS. 02322 · (617) 588-7700  
CABLE: WESTCORP, AVON · TELEX: 92-4444

SERVICE BULLETIN #76 con't.

has not been screwed in far enough. In either case, re-adjustment should be made accordingly.

CAUTION: Use extreme caution when tightening the locknut or the bleed screw because the "threaded boss" that the assembly is screwed into is pressed into the governor housing. It is not an integral part. Therefore, if it is loosened or turned through over-torquing, replacement of the complete governor housing may become necessary.

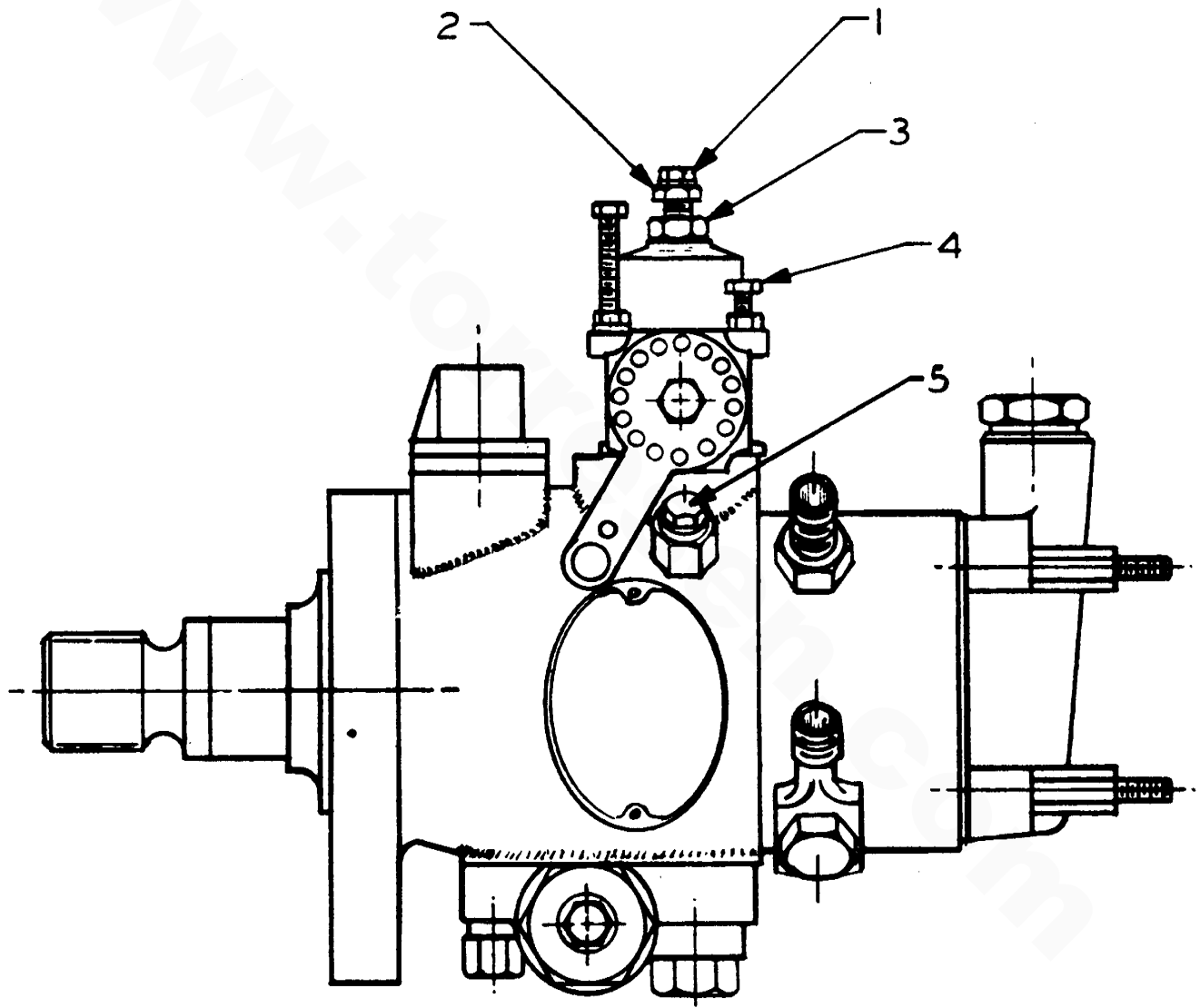

On all prewired engines dating from early 1975 onwards bleed screw (#5) has been relocated to the opposite side of the fuel injection pump.

# SERVICE BULLETIN

**DATE:** May 19, 1980

**BULLETIN NUMBER:** 82

**MODEL:** A11

**SUBJECT:** Battery Recommendations

## BATTERY RECOMMENDATIONS

<u>MODEL</u>	<u>BATTERY AMPERE HOURS</u>	<u>VOLTAGE</u>
W-7, & WPD4	60-90	12 V.D.C.
W-13 & 4.4 KW	90-125	12 V.D.C.
W-21 & 7.7 KW	90-125	12 V.D.C.
W-27 & 11 KW	90-125	12 V.D.C.
W-33	90-125	12 V.D.C.
W-30	125-150	12 V.D.C.
W-40, & WPD-10-15 KW	125-150	12 V.D.C.
W-50	125-150	12 V.D.C.
W-58 & WTO-20 KW	125-150	12 V.D.C.
W-60 & WBO-20 KW	150-170	12 V.D.C.
W-80 & 30KW	170-200	12 V.D.C.
W-120 & 45 KW	200 minimum	12 V.D.C.

The ampere hour range shown is minimum. There is no real maximum.



**J. H. WESTERBEKE CORP.**

AVON INDUSTRIAL PARK, AVON, MASS. 02322 · (617) 588-7700  
CABLE: WESTCORP, AVON · TELEX: 92-4444

V.8

# SERVICE BULLETIN

DATE: September 4, 1975

BULLETIN NUMBER: 84

MODEL: A11

SUBJECT: Heat Exchanger Rubber End Cap

Many heat exchangers supplied on our various products incorporate a molded rubber end cap to facilitate inspection of the tubes.

There have been occasions on which engine overheating has been caused by the improper positioning of this rubber end cap.

It is absolutely essential that the molded channel running across the inside of the cap be positioned over the baffle of the heat exchanger, according to the drawing below.

In any cases of engine overheating where such a rubber end cap is used, it should be checked for proper positioning along with other routine troubleshooting.

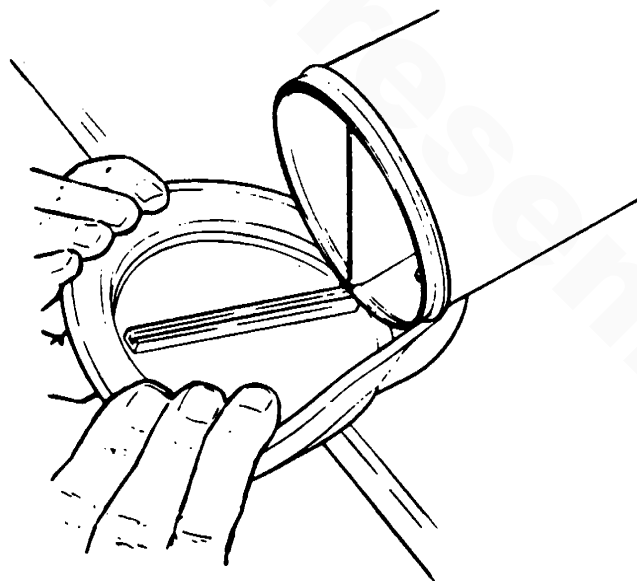

**J. H. WESTERBEKE CORP.**

AVON INDUSTRIAL PARK, AVON, MASS. 02322 · (617) 588-7700  
CABLE: WESTCORP, AVON · TELEX: 92-4444

# SERVICE BULLETIN

V.9

**DATE:** April 4, 1983

**BULLETIN NUMBER:** 87

**MODEL:** All Marine Engines

**SUBJECT:** Alternator Output Splitter

**GENERAL DESCRIPTION:** The splitter is a solid state device which allows two batteries to be recharged and brought to the same ultimate voltage from a single alternator as large as 120 amp and, at the same time, isolates each battery so that discharging one will have no effect on the other. Charging rates are in proportion to the batteries' voltage (state of discharge). This method precludes the necessity, and even the desirability of a rotary switch for selecting which battery is to be charged. It also assures that ships services cannot drain the engine starting battery.

## INSTALLATION:

1. Mount splitter on a metal surface other than the engine, preferably in an air stream if available. Do not install near engine exhaust system. Install with cooling fins aligned vertically.
2. Be sure to use a wire size appropriate to the output of the associated alternator. In full power systems number 4 wire is recommended from the alternator to the splitter and from the splitter to the batteries.
3. Connect the alternator output terminal to the center splitter terminal.
4. Connect one splitter side terminal to one battery (s).
5. Connect the other splitter side terminal to the other battery(s).
6. When the splitter is installed, both batteries will see a charging voltage 8/10 volts less than usual. This voltage drop can be regained, if desired, by connecting the regulator wire directly to the alternator output terminal instead of the regulator terminal.

**TEST INFORMATION:** When the engine is not running, the side splitter terminals should read the voltage of the respective battery. The center splitter should read zero voltage.

With the engine running and alternator charging, the side splitter terminals should read the same voltage which should be the voltage of the regulator or somewhat less. The center splitter terminal should read .82 volts higher than the readings of the side terminals.

Continued...



**J. H. WESTERBEKE CORP.**

AVON INDUSTRIAL PARK, AVON, MASS. 02322 (617) 588-7700  
CABLE: WESTCORP, AVON · TELEX: 92-4444

SERVICE BULLETIN #87 (Continued)  
(Alternator Output Splitter)

This unit is sealed for maximum life and is not repairable.

BY-PASSING SPLITTER: In the event of failure, batteries may be charged directly from alternator by connecting either splitter terminal #1 or #2 to terminal A, bypassing the splitter itself. This should not be done simultaneously for both batteries unless they are, and will remain at, the same voltage (state of charge.)

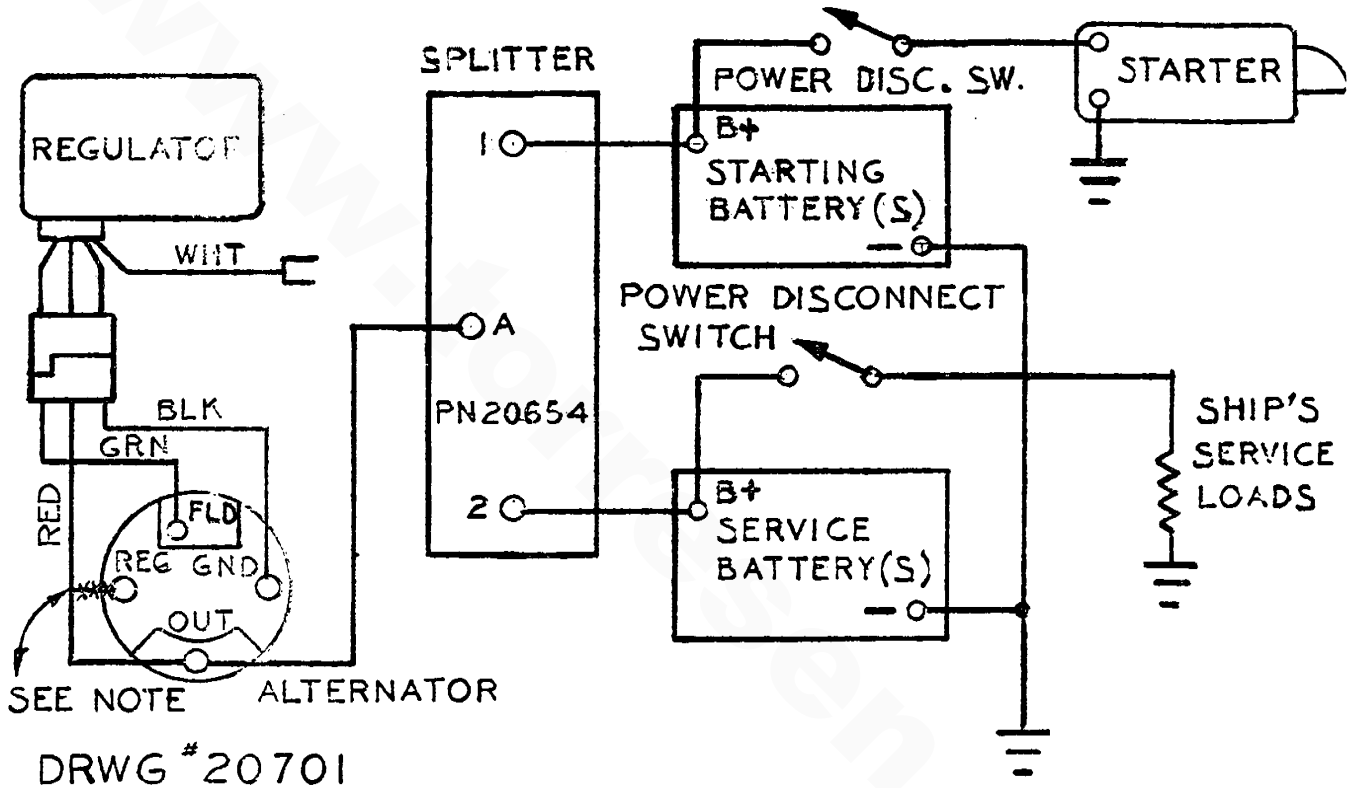

NOTE: On Alternators which have an isolation diode between their output and regulator terminals, such as the Motorola units used with most WESTERBEKE engines, the regulator wire should be removed from the REG terminal and reconnected to the OUTPUT terminal as shown. The diode in the splitter will provide an equivalent voltage drop.

**DATE:** April 28, 1976

**BULLETIN NUMBER:** 92

**MODEL:** A11

**SUBJECT:** Troubleshooting Water Temperature and Oil Pressure Gauges

Given a presumably faulty gauge indication with the instrument panel energized, the first step is to check for 12 VDC between the ign. (B+) and neg. (B-) terminals of the gauge.

Assuming there is 12 volts as required, leave the instrument panel energized and perform the following steps:

1. Disconnect the sender wire at the gauge and see if the gauge reads zero, the normal reading for this situation.
2. Connect the sender terminal at the gauge to ground and see if the gauge reads full scale, the normal reading for this situation.

If both of the above gauge tests are positive, the gauge is undoubtedly O.K. and the problem lies either with the conductor from the sender to the gauge, or with the sender.

If either of the above gauge tests is negative, the gauge is probably defective and should be replaced.

Assuming the gauge is O.K., proceed as follows. Check the conductor from the sender to the sender terminal at the gauge for continuity.

Check that the engine block is connected to ground. Some starters have isolated ground terminals and if the battery is connected to the starter (both plus and minus) the ground side will not necessarily be connected to the block.

If the sender to gauge conductor is O.K. and the engine block is grounded, the sender is probably defective and should be replaced.



**J. H. WESTERBEKE CORP.**

AVON INDUSTRIAL PARK, AVON, MASS. 02322 · (617) 588-7700  
CABLE: WESTCORP, AVON · TELEX: 92-4444



# SERVICE BULLETIN

DATE: June 22, 1976

BULLETIN NUMBER: 93

MODEL: A11

SUBJECT: Adjusting Paragon P200 Series Reverse Band

If the boat moves forward when the gear is in neutral at proper idle speed, the reverse band may be out of adjustment. When adjusting, be very careful not to get reverse band too tight or it will burn out. If the boat goes backwards when in neutral, it may be too tight.

The following adjustment procedure should only be carried out when it is not possible to obtain the service of an authorized Paragon transmission service dealer.

#### To Adjust:

On the outside left side of the gear there is a bolt in the mounting pad. Under its head are 1 to 3 washers. Remove one washer. This should stop forward boat movement. But under NO circumstances use fewer than one washer nor more than three.



**J. H. WESTERBEKE CORP.**

AVON INDUSTRIAL PARK, AVON, MASS. 02322 · (617) 588-7700  
CABLE: WESTCORP, AVON · TELEX: 92-4444

**DATE:** September 9, 1976

**BULLETIN NUMBER:** 94

**MODEL:** A11

**SUBJECT:** Fuel Pressure Switch Installation

Overleaf is a parts list and an illustration showing the proper installation of the fuel pressure switch used on most of our engine products.

[www.torresen.com](http://www.torresen.com)



**J. H. WESTERBEKE CORP.**

AVON INDUSTRIAL PARK, AVON, MASS. 02322 · (617) 588-7700  
CABLE: WESTCORP, AVON · TELEX: 92-4444

DATE	BY	REVISION RECORD	AUTH	DR

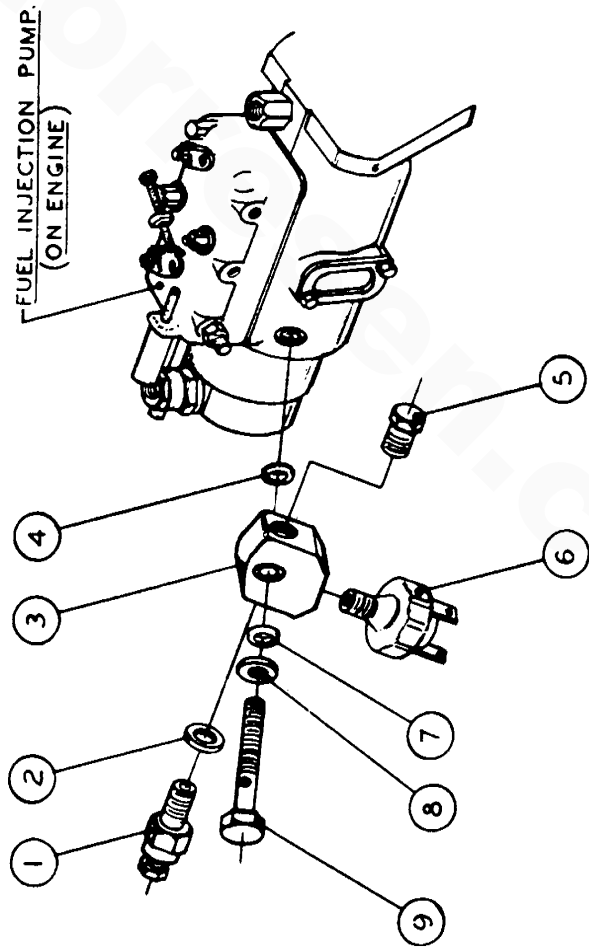

ITEM	19187	19442	19320	11383	11615	19321	19185	19261	19204	PART NO.	DESCRIPTION	QTY
9											HEX HD. SCREW	1
8											FLAT WASHER	1
7											0" RING 7/16 O.D.	1
6											FUEL PRESSURE SWITCH	1
5											PLUG	1
4											0" RING 9/16 O.D.	1
3											ADAPTER	1
2											COPPER WASHER	1
1											SCREW ASS'Y (BLEED)	1

TOLERANCES (EXCEPT AS NOTED)	J. H. WESTERBEKE CORP. AVON, MA. 02322	
DECIMAL	ALL ENGINES	SCALE NONE
FRACTIONAL		DRAWN BY B.J.S.
ANGULAR		APPROVED BY
	TITLE INSTALLATION DWG, FUEL PRESS. SWITCH TO A FUEL INJECTION PUMP	
	DATE 9-9-76	DRAWING NUMBER 21743

ALBANESE 19 P455  
 ENGINEERS STANDARD FORM  
 MADE IN U.S.A.

# SERVICE BULLETIN

DATE: 7 July 80 Reissued

BULLETIN NUMBER: 95

MODEL: A11

SUBJECT: Domestic Hot Water Heaters

PRINCIPLE

The heater is connected in series with the engine's freshwater circuit. This allows full water flow for maximum heat transfer to the heater. The series installation also avoids several potential pitfalls of installations in which the heater is in parallel with either the engine's by-pass or its internal freshwater circuit.

The only potential disadvantage of a series installation is flow restriction due either to a restrictive heater design, a large engine water flow (such as models W58, W80, W120), or a combination of both.

Installation

The shorter the length of piping to and from the heater, the better. The elevation of the heater should assure that the top of its internal coil is no higher than the engine pressure cap. If the heater must be higher than this at any heel angle, then the optional remote fill tank must be installed to be the highest point of the circuit.

Piping between the engine and heater should rise continuously from the heater to the engine so that trapped air will rise automatically from the heater to the engine. If trapped air can rise to the heater, then a petcock or other convenient method of bleeding that air is a necessity.

Study the attached sketches. A convenient place to interrupt the engine cooling circuit is between the thermostat housing outlet and the exhaust manifold inlet. This is also the hottest water available. CAUTION: While most owners want the hottest water available, it is possible for scalding water or even steam to come from the faucets.

Since the heater is in series with the engine cooling water, any other convenient point of the circuit can also be interrupted for heater installation.

Some engine/heater combinations require that a "by-pass" nipple be installed in parallel with the heater. This is required to maintain an adequate fresh water flow for cooling capability. The table below shows the minimum diameter of "by-pass" nipples in these situations:

MODEL	HEATER		
	SENDURE	ALLCRAFT	RARITAN
W30			3/8" NPT
W40			3/8" NPT
W50			1/2" NPT
W58	1/2" NPT	1/2" NPT	3/4" NPT
W80	1/2" NPT	1/2" NPT	3/4" NPT
W120	1/2" NPT	1/2" NPT	3/4" NPT

Please see sketches on overleaf.



**J. H. WESTERBEKE CORP.**

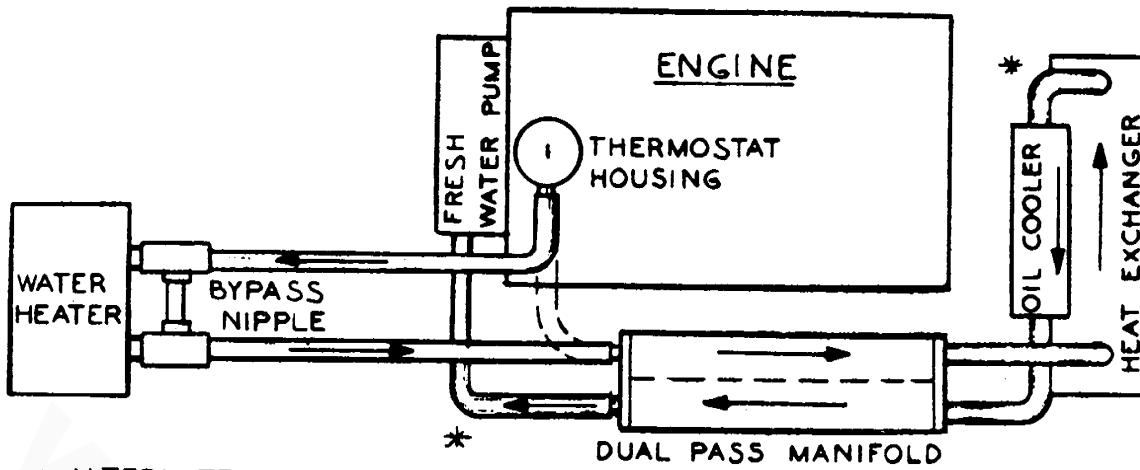

\* ALTERNATE PLACES TO INTERRUPT CIRCUIT AND CONNECT HEATER IN SERIES.

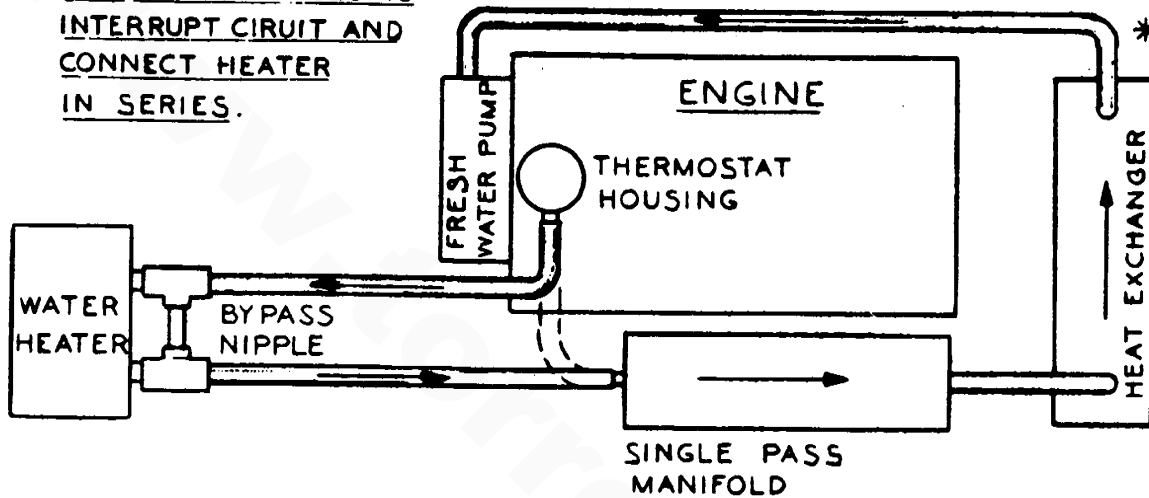

PRESSURE CAP (MUST BE HIGHER PRESSURE THAN ENGINE CAP).

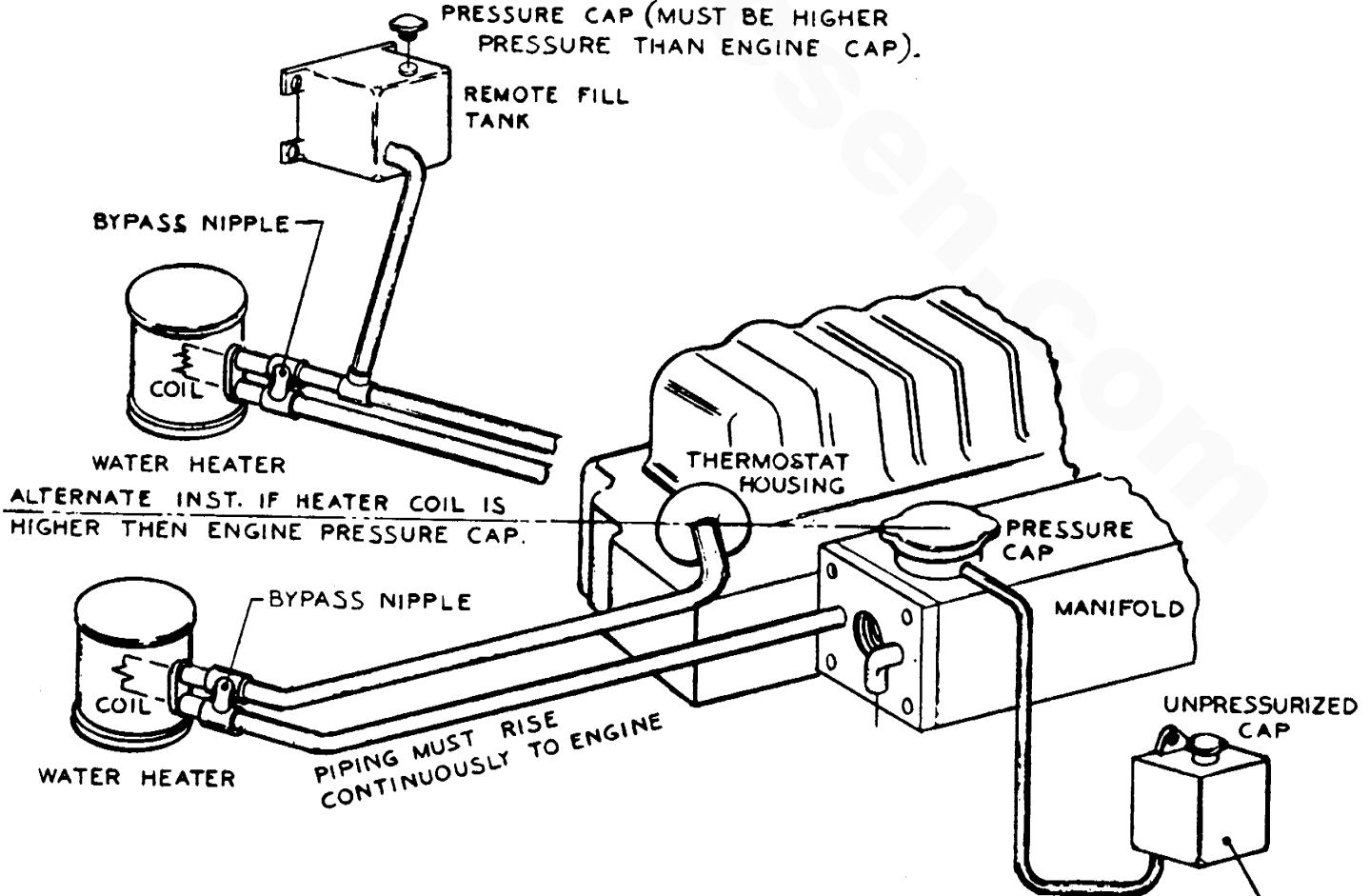

OPTIONAL COOLANT RECOVERY TANK

# SERVICE BULLETIN

DATE: January 22, 1980

BULLETIN NUMBER: 104

MODEL: Westerbeke 30 and 50

SUBJECT: Sea Water Pump Pulley Set Screw P.N. 11357

The sea water pump pulley on the Westerbeke 30 and 50 engines is keyed to the sea water pump shaft and locked in position with a heat treated 5/32" Allen head set screw, Westerbeke P.N. 11357.

Particular attention should be paid to this set screw at the time of commissioning of the engine and during regular servicing of the engine. Ensure that it is tight. If not, remove the set screw and apply a good locking liquid to the set screw threads and reinstall and tighten with the aid of a 5/32" Allen wrench.

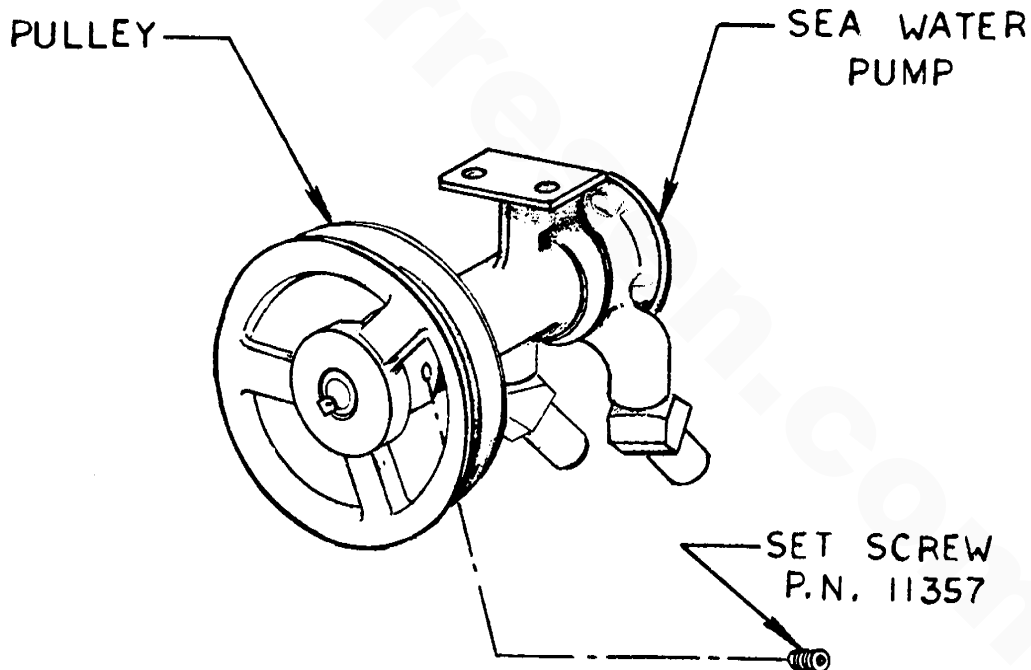

**J. H. WESTERBEKE CORP.**

AVON INDUSTRIAL PARK, AVON, MASS. 02322 · (617) 588-7700  
CABLE: WESTCORP, AVON · TELEX: 92-4444

# SERVICE BULLETIN

**DATE:** May 1, 1980

**BULLETIN NUMBER:** 107

**MODEL:** All Models

**SUBJECT:** Thermostats

Beginning approximately May, 1980, thermostats supplied by the factory have a by-pass hole sufficient to allow adequate water flow through the exhaust manifold, head, and block, during engine warm-up.

This flow is mandatory, especially in the case of marine engines and generator sets which have significant load applied soon after start-up.

We strongly recommend that only genuine WESTERBEKE thermostats be used in WESTERBEKE products to assure proper design in this regard.



**J. H. WESTERBEKE CORP.**

AVON INDUSTRIAL PARK, AVON, MASS. 02322 · (617) 588-7700  
CABLE: WESTCORP, AVON · TELEX: 92-4444

# SERVICE BULLETIN

**DATE:** May 5, 1980

**BULLETIN NUMBER:** 108

**MODEL:** ALL

**SUBJECT:** Circuitry Change for Marine Propulsion Engines

With the W58 we introduce a new electrical circuit which will eventually be used on most models.

Some features of the new circuit are as follows:

1. A voltmeter is substituted for an ammeter. Naturally an ammeter can still be installed separately.
2. All wires between the engine and the instrument panel need not be heavier than 14 AWG.
3. The panel contains controls for preheating and starting the engine, eliminating the necessity for a separate control panel. Of course the controls can be installed remotely from the panel by the builder if desired.
4. The circuit allows commonization of the instrument panel across the broadest possible range of engine models, simplifying the distribution of spare parts.
5. The circuit allows commonization of engine wiring harnesses across the broadest range of engine models, simplifying the distribution of spare parts.

The same connectors and color coding of the connector poles are used on both new and old harnesses and cables. Functional color codes are not necessarily the same in new and old circuits. The new panel will not operate with an older engine, and new engines will not operate with an older panel. Because the connectors are the same, a physical mating of old and new components is possible, but neither the panel nor the engine will operate and no harm can be done by accidental mismatching.

Please see diagram on overleaf.



**J. H. WESTERBEKE CORP.**

AVON INDUSTRIAL PARK, AVON, MASS. 02322 (617) 588-7700  
CABLE: WESTCORP, AVON · TELEX: 92-4444



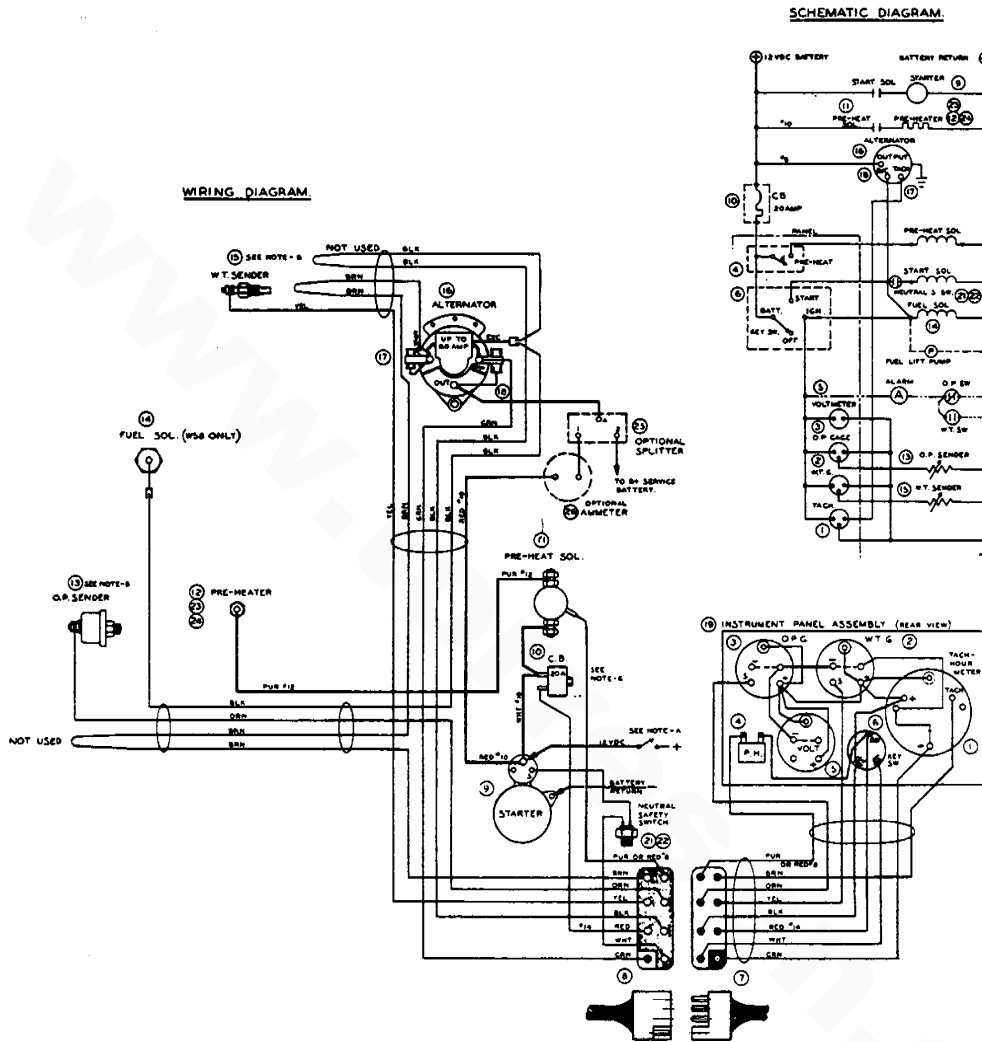

# SERVICE BULLETIN

**DATE:** May 5, 1980  
**MODEL:** W58  
**SUBJECT:** Two Pass Manifold

**BULLETIN NUMBER:** 109

The W58 employs a two pass manifold. It is a key feature of a new cooling system first appearing on the W58. The system is vented by the pressure cap at the return side of the fresh water circulating pump, the point of the lowest pressure within the system. This has the advantage of increasing cooling capacity by preventing cavitation at the fresh water pump under higher temperature conditions.

This system will ultimately be incorporated on most models.

The schematic on the overleaf shows the water flow. Operation of the circuit is as follows:

1. The thermostat has a permanent by-pass port of .06 square inches to assure water flow through the manifold while the engine is warming up. Replacement thermostats must have this permanent by-pass port.
2. Hot water leaving the engine thermostat housing passes through the inside half of the water jacketed exhaust manifold to the heat exchanger inlet.
3. Water leaving the heat exchanger enters a fresh water cooled oil cooler, if used.
4. Water leaving the oil cooler or heat exchanger enters the outside half of the water jacketed manifold.
5. The outside half of the manifold is comprised of two sections: a cooling path adjacent to the exhaust passage and an air removal path which allows entrained air to rise to the top of the manifold.
6. The pressure cap is located at the top of the air removal path.
7. From the manifold, coolant returns to the suction side of the fresh water pump.

The system is designed to accept an optional coolant recovery tank. This useful accessory offers several advantages, including:

1. A remote fill point for the circuit, in which case it should be located slightly higher than the engine's pressure cap.

Continued.....



**J. H. WESTERBEKE CORP.**

AVON INDUSTRIAL PARK, AVON, MASS. 02322 • (617) 588-7700  
CABLE: WESTCORP, AVON • TELEX: 92-4444

24721

2. A means of conveniently observing the water level in the circuit.
3. A means of assuring that the circuit is always completely full of cooling water.
4. The coolant recovery system operates without diverting engine cooling water. It is a one-way connection to the system which provides a place for expanding water to go while the engine is warming up and, conversely, a source of water to refill the system as the engine cools down.

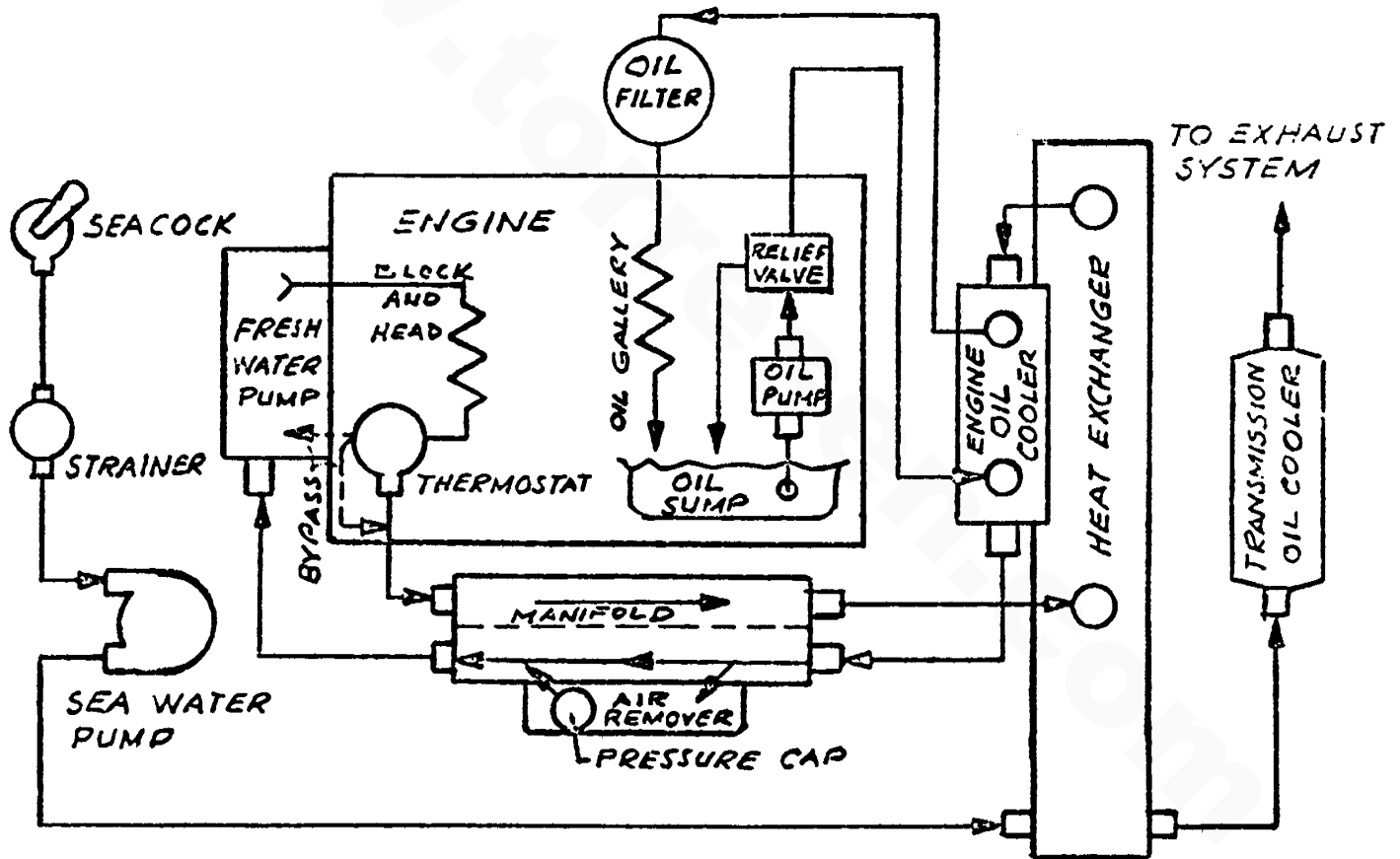

# SERVICE BULLETIN

**DATE:** May 20, 1980

**BULLETIN NUMBER:** 110

**MODEL:** A11

**SUBJECT:** Ammeter Wire Sizes

Ammeters may be installed in conjunction with any Westerbeke marine diesel engine or diesel generator set. The range of the ammeter must be appropriate for the maximum output of the alternator.

Additionally, the wire size for the alternator output circuit, including the ammeter, varies with the total length of that circuit. The table below shows the maximum current that can be carried various total distances by various wire sizes, to and from source to load.

System Volts	Total Length of wire in feet	WIRE SIZE TABLE						
		MAXIMUM CURRENT (AMPS)						
		35	40	55	60	70	85	120
12	1 to 5	12	12	12	8	8	8	6
12	5 to 10	10	10	8	6	6	6	4
12	10 to 20	6	6	6	6	3	2	1
12	20 to 30	6	4	4	2	1	1	1
12	30 to 40	4	2	2	1	1	0	0
24	1 to 5	14	14	12	12	10	10	8
24	5 to 10	12	12	10	10	8	8	6
24	10 to 20	10	8	8	6	6	4	4
24	20 to 30	8	6	6	4	4	4	2
24	30 to 40	6	6	4	4	2	2	0
32	1 to 5	14	14	12	12	10	10	8
32	5 to 10	12	12	10	10	8	8	6
32	10 to 20	10	8	8	6	6	4	4
32	20 to 30	8	6	6	4	4	4	2
32	30 to 40	6	6	4	4	2	2	0



**J. H. WESTERBEKE CORP.**

AVON INDUSTRIAL PARK, AVON, MASS. 02322 · (617) 588-7700  
CABLE: WESTCORP, AVON · TELEX: 92-4444

P/N: 24737

# SERVICE BULLETIN

DATE: December 8, 1983

BULLETIN NUMBER: 130

MODEL: W50

SUBJECT: On Engine Fuel System - Bleed Procedure

(REFER TO THE ILLUSTRATION WHEN FOLLOWING THE PROCEDURE BELOW)

1. After air has been bled from that portion of the fuel system between the fuel tank and engine, the use of the manual primer on the fuel lift pump can aid in accomplishing this, proceed to bleed point #1 with a 5/8" box wrench. Loosen this banjo bolt 1 - 2 turns. (Do not remove the bolt from the filter.) Work the manual priming lever on the fuel lift pump and purge all air out of the secondary filter until fuel free of air bubbles flows from around this banjo bolt. Once fuel free of air flows from around the bolt, retighten the bolt.

NOTE #1: You may want to place a small plastic garbage bag around and under the secondary filter with a few paper towels to catch the fuel.

NOTE #2: When working the manual priming lever on the fuel lift pump, move it with long and deliberate strokes - NOT rapidly. In some rare instances, the lift pump may internally be at or near the maximum pump stroke and no pumping action will be achieved using the manual external priming lever, making it necessary to turn the engine over slightly with the starter to reposition the pump internally.

2. With the aid of a 5/16" box wrench, or socket (1/4" Drive), open the bleedscrew #2 on the side of the fuel injection pump, 1 or 2 turns. DO NOT remove the screw. Again work the manual priming lever on the engine-mounted fuel lift pump; purge all air from this area of the fuel injection pump and when fuel free of air flows, retighten the bleedscrew #2.

NOTE: Models with pushbutton starting refer to the inset for point #2A located on the fuel pressure switch manifold mounted at bleed point #2 on the injection pump. Bleed #2A as above.

3. With the aid of 5/16" box wrench or socket (1/4" Drive) open the bleedscrew #3 and bleed this portion of the injection pump as in Step #2.

NOTE: Ensure that the throttle is full open and the engine shut-off lever is in the RUN position when proceeding to Step #4.

over.....



**J. H. WESTERBEKE CORP.**

AVON INDUSTRIAL PARK, AVON, MASS. 02322 · (617) 588-7700  
CABLE: WESTCORP, AVON · TELEX: 92-4444

P/N: 33547

-2-

4. With the aid of a 5/16" box wrench or socket (1/4" Drive), open the bleedscrew #4 located at the base of the high pressure line 1 to 2 turns.

NOTE: DO NOT remove this bleedscrew. At the same time with a 5/8" open-end wrench, loosen all four high pressure injector line nuts #5 at the base of each fuel injector 1 to 2 turns. With the engine starter, bleed Point #4 on the high pressure line by cranking the engine over with the starter motor and when fuel free of air flows from bleedscrew #4, stop cranking with the starter and retighten bleedscrew #4.

5. Again crank the engine over with the starter until fuel spurts between the 5/8" nut and the high pressure injector line at the base of each injector Bleed Point #5. When fuel spurts between the line and nut at each of these four points, stop cranking and re-secure these nuts with the 5/8" open-end wrench.

NOTE: Extensive torque is not required on these nuts to properly seat the high pressure injector lines to the base of the injectors.

6. The engine is now ready to start. Leaving the throttle in the FULL OPEN position and ensuring that the engine STOP lever is in the RUN position and the transmission is in NEUTRAL, proceed to start the engine. Preheat as required and crank the engine over with the starter. Once the engine fires, return the throttle to IDLE position, and ensure that proper engine oil pressure is achieved, and that raw water is being discharged with the exhaust.

Allow the engine to run at 1000-1200 RPM for five minutes, to be sure that all air has been bled from the fuel system.

NOTE: When routine servicing of the on-engine secondary fuel filter is being accomplished, bleed points #1 and #2 should only be bled to ensure that all air has been removed from the system. No other bleed points need be bled at this time.

Owners may find it advantageous to daub white paint onto each of the bleed points, so if an unexpected problem arises requiring engine fuel system bleeding, these points will be readily visible.

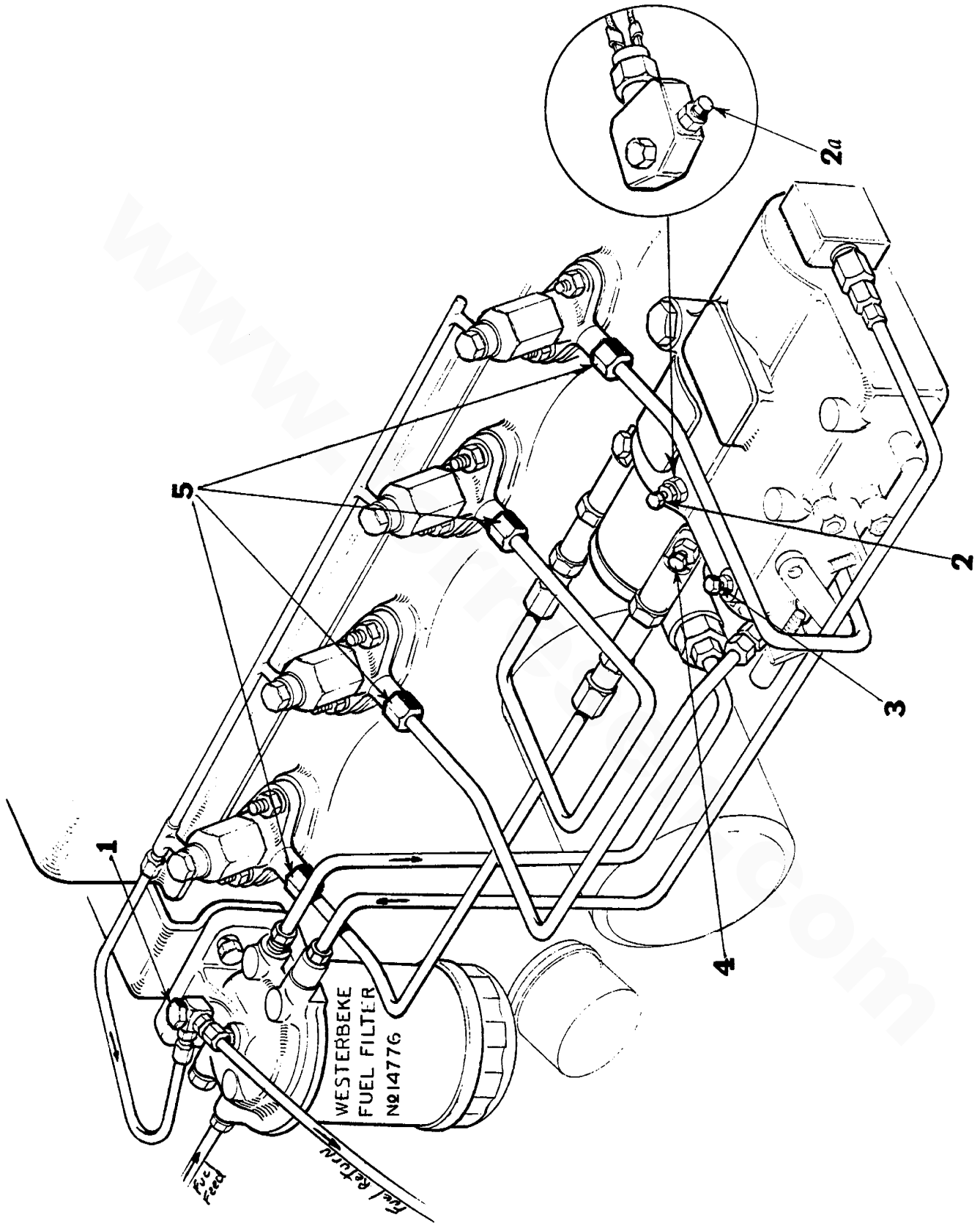

**DATE:** December 5, 1984

**BULLETIN NUMBER:** 139

**MODEL:** All Propulsion and Generator Models

**SUBJECT:** Hydro-Hush Muffler Installations

The illustrations shown with this text should be used as a guide when making an installation of a Hydro-Hush Muffler.

When used in conjunction with propulsion engine, the Hydro-Hush Muffler should be mounted close to the fore-aft center line of the boat. When used with a generator unit, the muffler should be as close as possible to the generator.

All installations should be such that the entry of water into the engine exhaust manifold and cylinders is prevented while under sail and at various angles of heel, from following seas, when backing down, or any other condition.

Units installed with the exhaust manifold/water injected exhaust elbow at or below the water line of the vessel must install a vent or syphon break in the sea water supply line to the water injected exhaust elbow. The seawater supply line must be looped above the water line a minimum of six (6) inches with the vent or syphon break installed at the top of this loop.

The vented loop, when used, can be a mechanical syphon break as shown in the illustration or a simple tee arrangement with a small hose or tube (3/16-1/4 inch I.D.) routed to the transom exhaust discharge or to a separate thru-hull fitting located above the water line. This hose or tube must be routed in such a way that it will drain of water when the engine is shut down and allow air into the sea water supply hose and injection elbow.

The syphon break or vent is installed to break the vacuum in the sea water cooling circuit and thereby discourage syphoning of sea water through this circuit, and subsequently filling of the exhaust and engine cylinders with sea water. When used, syphon breaks should be checked periodically for proper operation and should be installed in a location where, should they leak sea water, it would not leak onto the engine or its accessories.

The syphon break or vent must be located above the vessel's water line high enough so as to remain above the water line at all angles of vessel heel and pitch.

The Hydro-Hush Muffler remains approximately 30% full of water after engine shut-down when there is a maximum of 48 inches of lift on the discharge side.

The installation information given in this text is to be used as a guide only. Westerbeke cannot be responsible in any way for muffler installations. Westerbeke presumes the installer to have a basic knowledge of marine installation requirements.



**J. H. WESTERBEKE CORP.**

AVON INDUSTRIAL PARK, AVON, MASS. 02322 · (617) 588-7700  
CABLE: WESTCORP, AVON · TELEX: 92-4444

33934



Hydro-Hush Muffler Installations

Page 2

Use as few right angle fittings as possible. The use of wire reinforced hose is recommended and the hose should be routed to produce the bends needed.

The use of 90° and 45° fittings contribute to the rise of engine exhaust back pressure. (Refer to the Unit Technical Manual for back pressure specifications.)

The exhaust hose diameters shown are minimums. Exhaust hose diameter for the discharge hose will have to be increased if the length of run from the Hydro-Hush Muffler to the thru-hull discharge is excessive (25' to 30' depending on the number of bends).

CAUTION

THE SEA WATER PUMP WILL CONTINUE TO FILL THE EXHAUST SYSTEM WITH SEA WATER DURING CRANKING. THE ENGINE EXHAUST PRESSURE DURING CRANKING MAY NOT BE STRONG ENOUGH TO EXPEL THE WATER FROM THE MUFFLER AND PREVENT THE SYSTEM FROM FILLING UP WITH SEA WATER AND ENTERING THE EXHAUST MANIFOLD AND CYLINDERS.

IF ENGINE CRANKING EXCEEDS 30-40 SECONDS APPROXIMATELY, CLOSE THE SEA WATER THRU HULL AND OPEN IT IMMEDIATELY AFTER THE ENGINE STARTS.

ENGINE INSTALLATIONS

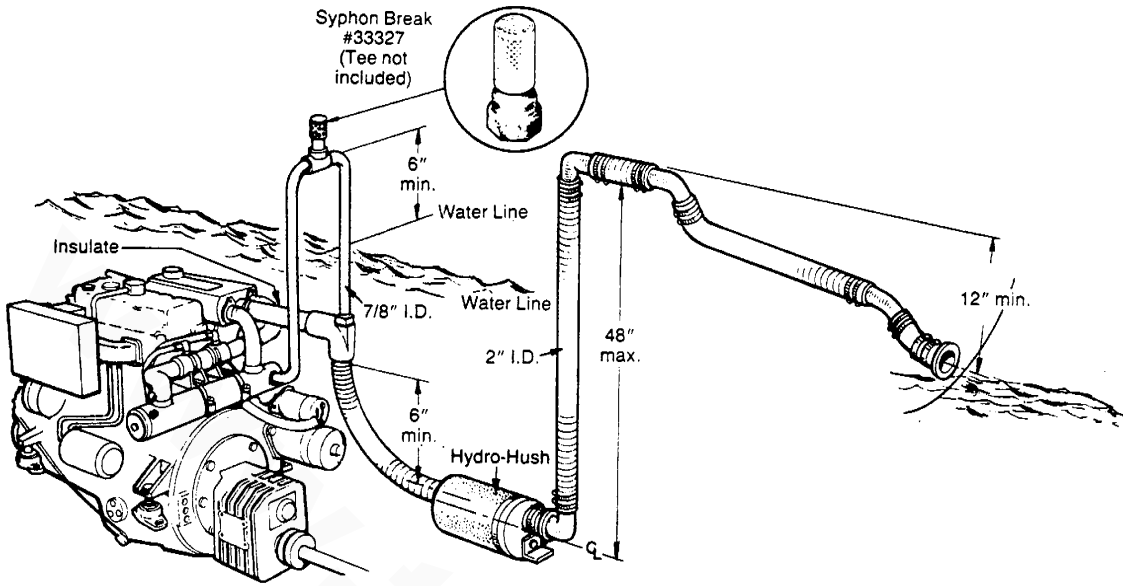

**ENGINE INSTALLATIONS WITH EXHAUST MANIFOLD/WATER INJECTED ELBOW AT OR BELOW VESSEL WATER LINE**

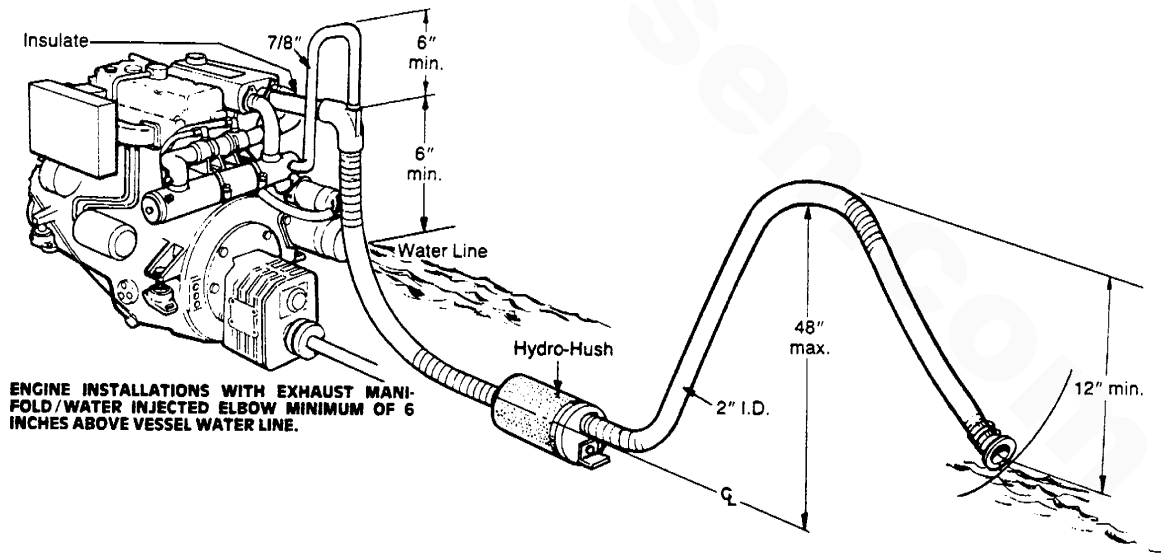

**ENGINE INSTALLATIONS WITH EXHAUST MANIFOLD/WATER INJECTED ELBOW MINIMUM OF 6 INCHES ABOVE VESSEL WATER LINE.**

GENERATOR INSTALLATIONS

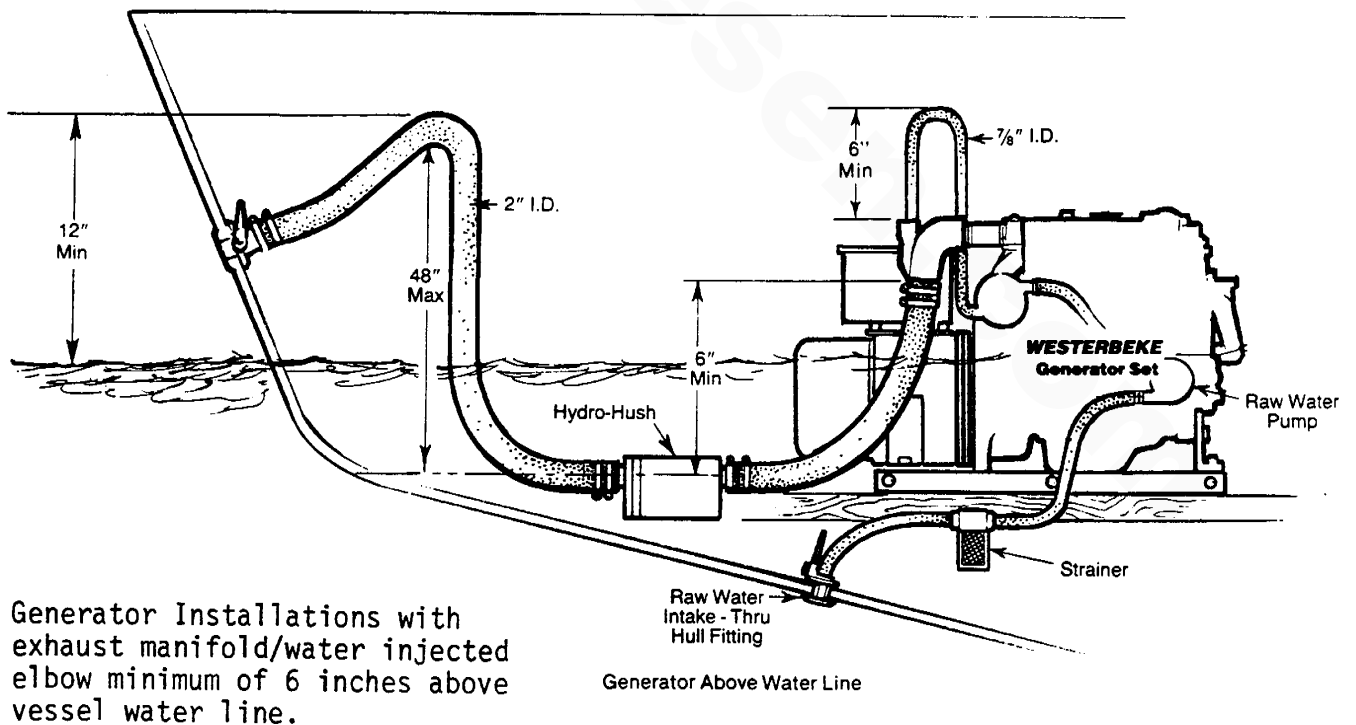
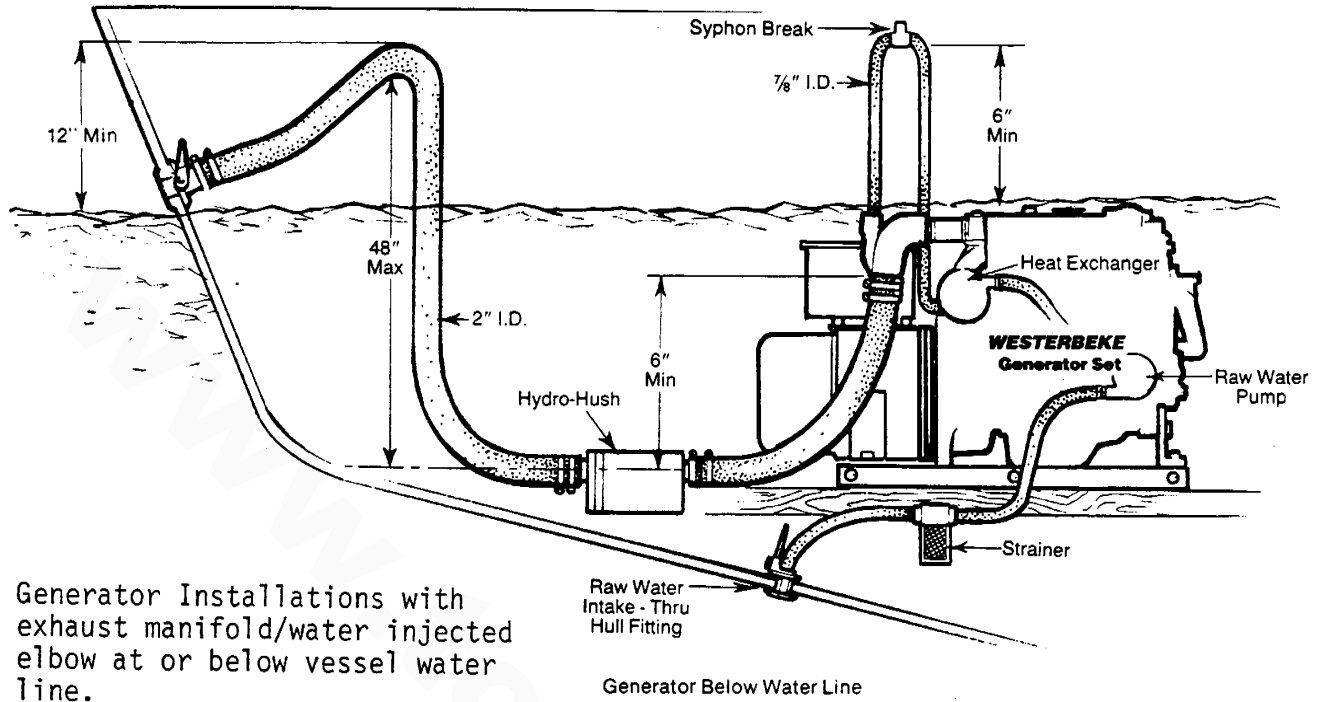

# SERVICE BULLETIN

DATE: 1/23/85

BULLETIN NUMBER: 148

MODEL: ALL PROPULSION ENGINES

SUBJECT: FIELD TROUBLESHOOTING TACHOMETER/HOURMETER PN 11917

The tachometer/hourmeter used in propulsion engine instrument panels contains two separate electrical circuits with a common ground. One circuit operates the hourmeter, and the other the tachometer. The hourmeter circuit operates on 12 volts/alternator charging voltage supplied to the (+) terminal on the back of the instrument.

The tachometer circuit operates on AC voltage 6-8 volts, fed from one of the diodes in the alternator and supplied to the "tach inp." terminal while the engine is running, and the alternator producing battery charging voltage 13.0-14.8 volts D.C.

The following are procedures to follow when troubleshooting a fault in either of the two circuits in the tachometer/hourmeter.

HOURMETER  
FAULT

CHECK

- 1. Inoperative
  - 1. Check for proper DC voltage between (+) and (-) terminals.
    - A. Voltage present - meter defective - repair or replace.
    - B. Voltage not present - trace (+) and (-) electrical connections for fault. (Jump 12 Volts DC to meter (+) terminal to verify operation.)

TACHOMETER  
FAULT

CHECK

- 1. Inoperative
  - 1. Check for proper AC voltage between "Tach Inp." terminal and (-) terminal with engine running.
    - A. Voltage present - attempt adjusting meter through calibration access hole. No results, repair or replace meter.
    - B. AC voltage not present - check for proper alternator D.C. output voltage.
    - C. Check for A.C. voltage at tach terminal on alternator to ground.
    - D. Check electrical connections from "tach Inp." terminal to alternator connection.



**J. H. WESTERBEKE CORP.**

AVON INDUSTRIAL PARK, AVON, MASS. 02322 · (617) 588-7700  
CABLE: WESTCORP, AVON · TELEX: 92-4444

2. Sticking

1. Check for proper A.C. voltage between "tach inp." terminal and (-) terminal.
2. Check for good ground connection between meter (-) Terminal and alternator.
3. Check alternator is well grounded to engine block at alternator pivot bolt.

3. Inaccurate

1. With hand-held tach on front crankshaft pulley retaining nut or strobe type tach read front crank shaft pulley R.P.M. Set engine R.P.M. with hand or strobe tach at 1500-1800 R.P.M.
2. Adjust tachometer with small Phillips type screwdriver through calibration access hole in rear of tachometer covered with translucent plug. Zero tach and bring to R.P.M. set by strobe or hand tach. (Verify R.P.M. at idle and at high speed 2500-3000 R.P.M.) (Adjust tach as needed.)

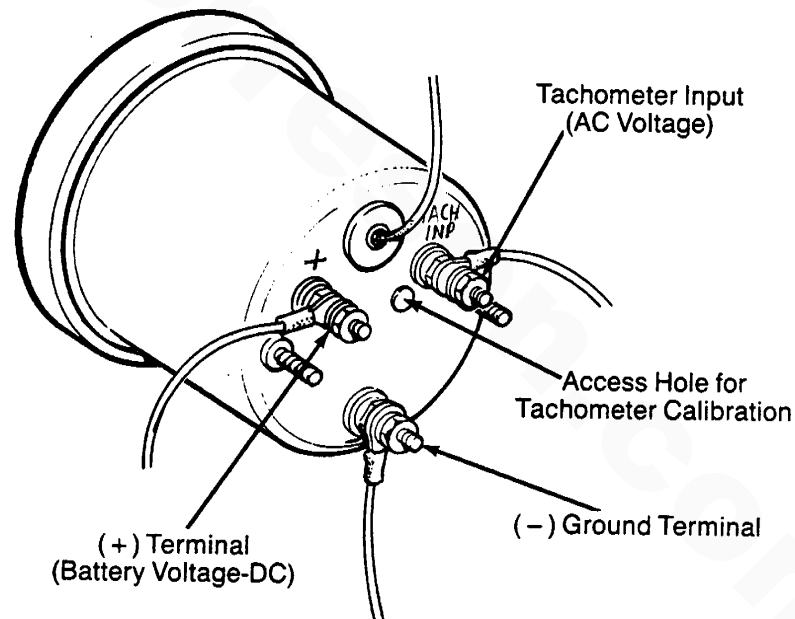

LATE MODEL TACHOMETER

Replaces Earlier Model as Shown on Page 2 of this Bulletin

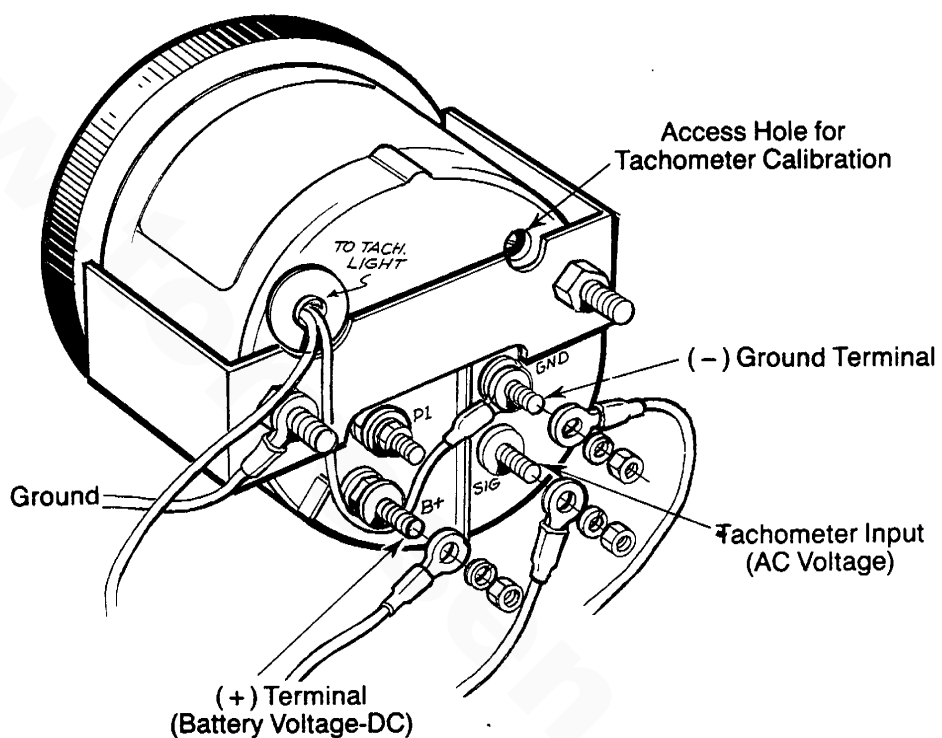

[www.torresen.com](http://www.torresen.com)