

# PARTS LIST

## **WESTERBEKE 50** **Marine Diesel Engine**

**Publication #23157**

Edition One

June 1978



NOTE

The Westerbeke policy is one of continuous improvement, and accordingly, the company reserves the right to alter specifications, weights and dimensions without prior notice.

In compiling this Parts List, every care has been taken, but specifications and details must not be regarded as binding.

Please, if you have a suggestion regarding this book, or feel there is an error, send a written note to the attention of Publications Department.

The unit of measure on linear commodities is the INCH (not feet or yards). The code in the quantity column "AR" indicates that quantity varies. Therefore, order amounts As Required.

TABLE OF CONTENTS

200	Cylinder Block - Piston
202	Cylinder Head
204	Crankcase - Rod - Camshaft
206	Rocker Shaft
208	Timing Cover
210	Sump - Lube Oil Pump
212	Crankcase Breather
214	Fuel System
218	Fuel Pressure Switch - Water Separator
220	Cooling System
224	Sea Water Pump
226	Mounts
226	Photographs of Engine
228	Back End Arrangement
230	Electrical System
234	Short Profile Sailing Gear - Model 10
238	Type SAO Manual Transmission
242	Miscellaneous

WESTERBEKE 50 - CYLINDER BLOCK - PISTON

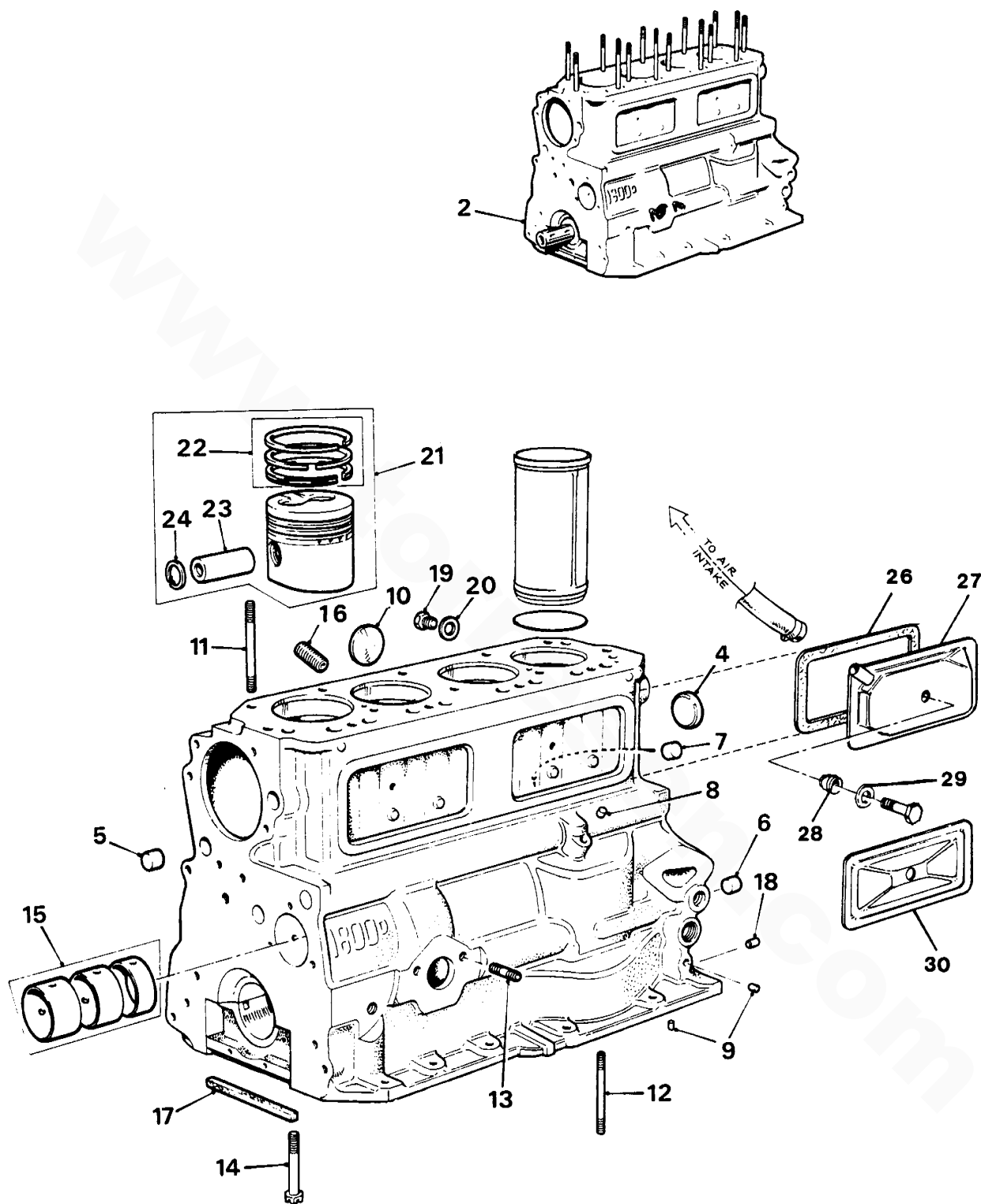

WESTERBEKE 50 - CYLINDER BLOCK - PISTON

REF	PN	NAME	REMARKS	QUAN
1	19404	ENGINE	ASSEMBLY	1
2- 1	23270	BLOCK	SHORT 738B/D101 THRU D459	1
2- 2	24045	BLOCK	SHORT 738B/D460 ON	1
4	23222	PLUG	CORE	2
5	23265	PLUG	OIL GALLERY	6
6	23266	PLUG	TAPER-OIL HOLE	1
7	14595	PLUG	TAPER-OIL HOLE	1
8	15481	PLUG	DRILLING TO CAMSHAFT BEARING	1
9	14561	PLUG	OIL RELIEF VALVE VENT HOLE	2
10	14553	PLUG	WELCH	3
11	14482	STUD	CYLINDER HEAD-SHORT	10
12	14558	STUD	OIL PUMP-NLA	
13	23264	STUD	FUEL PUMP	2
14	23263	BOLT	PLACE MAIN BEARING	10
15- 1	14606	LINER	CAMSHAFT BEARING 738B/D101 THRU D459	1
15- 2	24046	LINER	CAMSHAFT BEARING 738B/D460 ON	1
16- 1	23262	ADAPTER	OIL FILTER 738B/D101 THRU D459	1
16- 2	24047	ADAPTER	OIL FILTER 738B/D460 ON	1
17	17961	GASKET	MAIN BEARING END CAP	2
18	14437	DOWEL	BACKPLATE LOCATING	2
19	14649	PLUG	CYLINDER DRAIN	1
20	14453	WASHER		1
21- 1	23223	PISTON	ASSEMBLY STANDARD	4
21- 2	23260	PISTON	ASSEMBLY .020 O/S	AR
21- 3	23259	PISTON	ASSEMBLY .040 O/S	AR
22- 1	23258	RING SET	1 CYLINDER STANDARD	AR
22- 2	23257	RING SET	1 CYLINDER .020 OS	AR
22- 3	23256	RING SET	1 CYLINDER .040 OS	AR
23	23255	PIN	PISTON	4
27	14461	CIRCLIP		4
25	23254	LINER	CYLINDER	4
26	23189	GASKET	CYLINDER SIDE COVER-REAR-CORK	1
27	23362	COVER	CYLINDER SIDE-REAR	1
28	14563	BUSHING	RUBBER	1
29	14564	WASHER	CUP	1
30- 1	23190	COVER	CYLINDER SIDE COVER-FRONT	1
30- 2	14562	GASKET	CYLINDER SIDE COVER-FRONT-RUBBER	1

WESTERBEKE 50 - CYLINDER HEAD

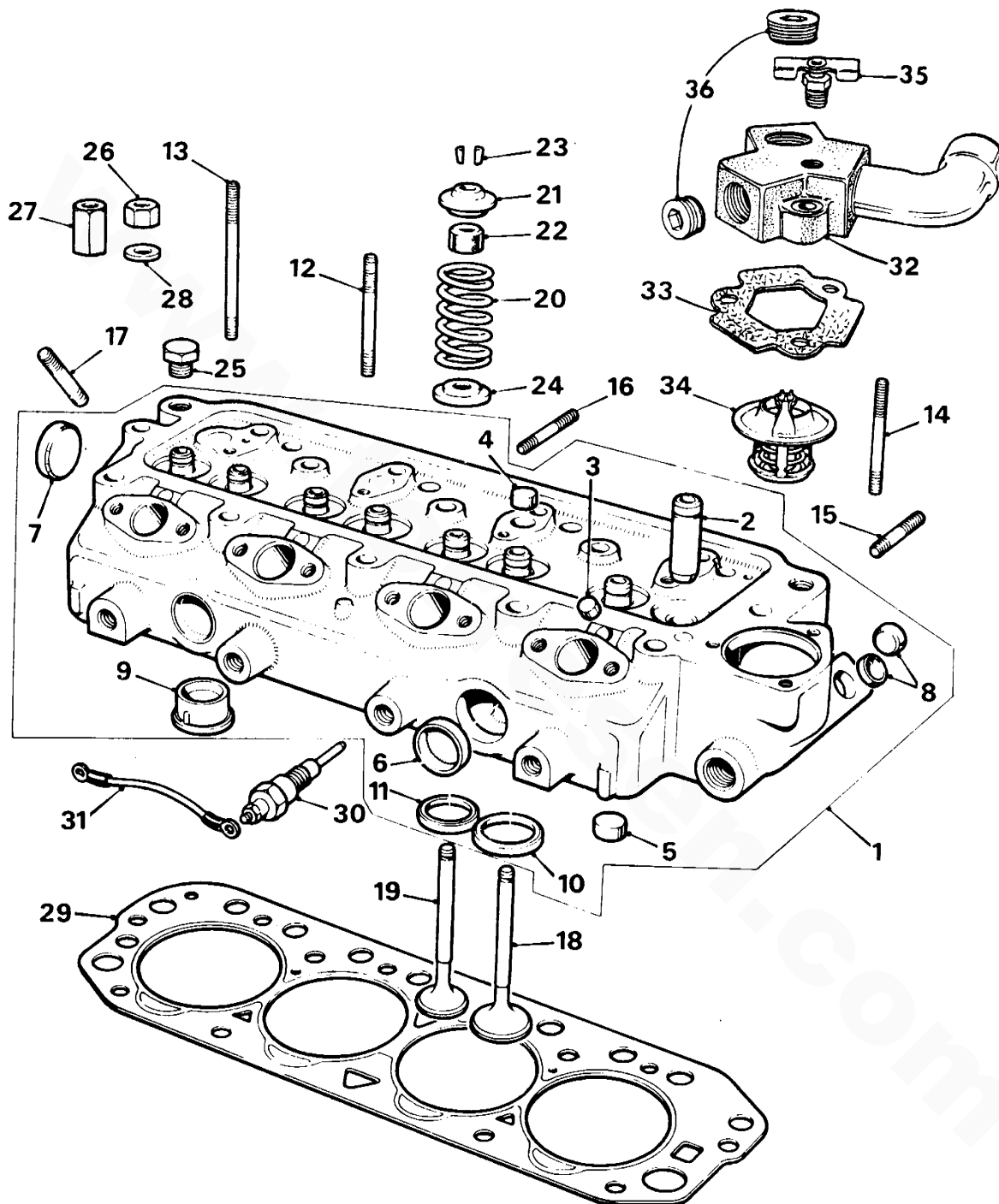

WESTERBEKE 50 - CYLINDER HEAD

REF	PN	NAME	REMARKS	QUAN
1- 1	23223	HEAD	ASSEMBLY-CYLINDER 738B/D101 THRU D459	1
1- 2	24048	HEAD	ASSEMBLY-CYLINDER 738B/D460 ON	1
2	14447	GUIDE	VALVE	8
3	14595	PLUG		5
4	23998	PLUG	CORE	1
5	14500	PLUG	CORE	7
6	14553	PLUG	CORE	3
7	14552	PLUG	OIL HOLE	1
8	23221	PLUG	CORE	2
9	23220	INSERT	COMBUSTION CHAMBER	4
10	23219	INSERT	VALVE SEAT-INTAKE	4
11	23218	INSERT	VALVE SEAT-EXHAUST	4
12	14556	STUD	ROCKER BRACKET-SHORT	2
13	14559	STUD	ROCKER BRACKET-LONG	2
14- 1	23995	STUD	THERMOSTAT HOUSING	3
14- 2	14440	WASHER		3
14- 3	14441	NUT		3
15	14637	STUD	EXHAUST MANIFOLD	2
16	23217	STUD	MANIFOLDS	4
17	14607	STUD	INJECTOR HOLDER	8
18	23216	VALVE	INTAKE	4
19	23215	VALVE	EXHAUST	4
20	23214	SPRING	VALVE	8
21	23213	COLLAR	VALVE SPRING	8
22	17729	SEAL	VALVE STEM OIL	4
23	20716	COTTER		8
24	23212	CUP	VALVE SPRING	8
25	14578	PLUG		2
26	14445	NUT	CYLINDER HEAD STUD	11
27	14511	NUT	PILLAR	3
28	23211	WASHER		14
29	23210	GASKET	HEAD	1
30	14529	PLUG	GLOW	4
31	14494	WIRE	GLOW PLUG	3
32	15760	HOUSING	THERMOSTAT	1
33	14501	GASKET	THERMOSTAT HOUSING	1
34	17926	THERMOSTAT	180F	1
35	11471	PETCOCK		1
36	11752	PLUG		2

WESTERBEKE 50 - CRANKCASE - ROD - CAMSHAFT

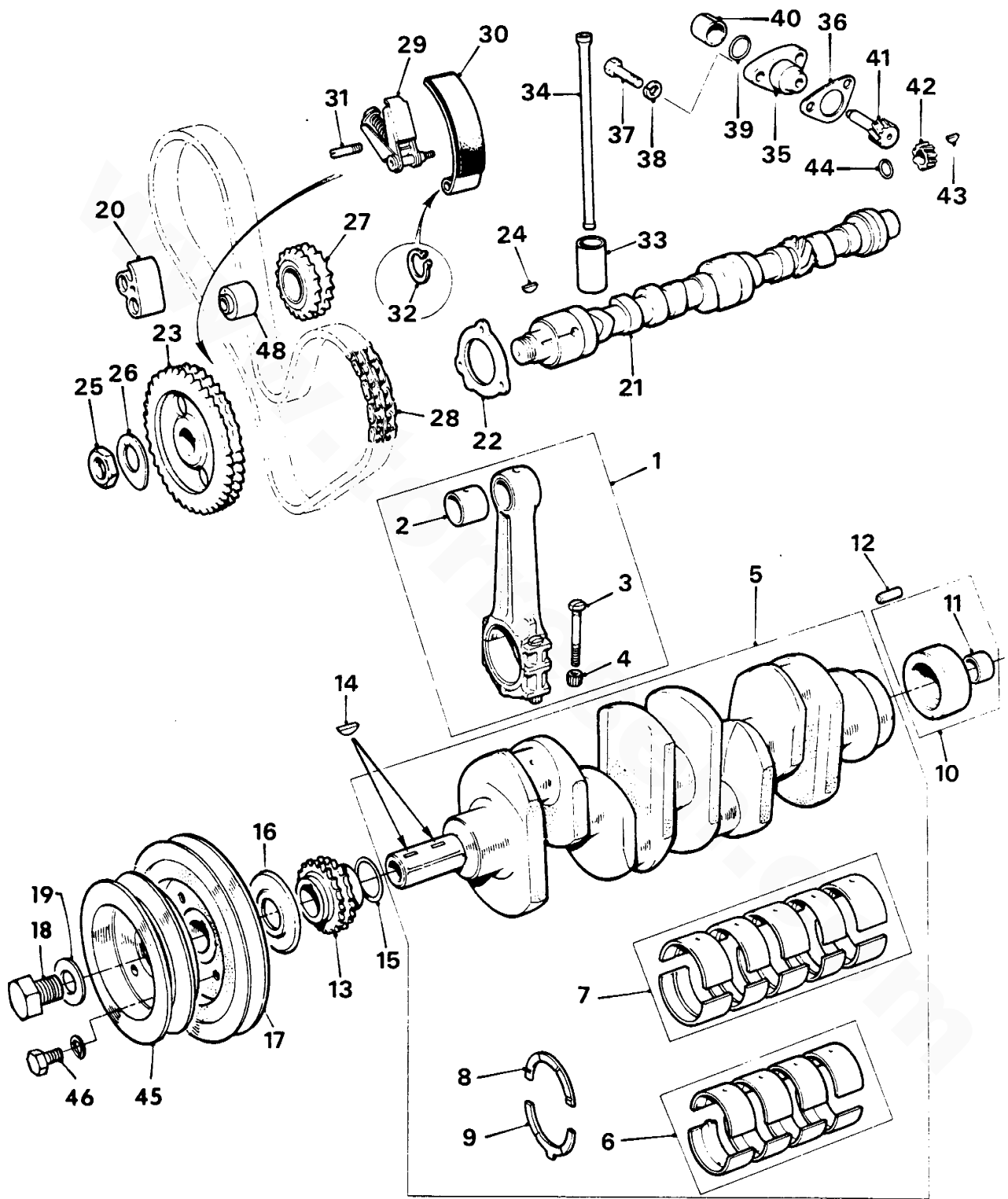



WESTERBEKE 50 - CRANKCASE - ROD - CAMSHAFT

REF	PN	NAME	REMARKS	QUAN
1	23253	ROD	CONNECTING,ASSEMBLY	4
2	14448	BUSHING		4
3	23252	CAPSCREW	CONNECTING ROD	8
4	23251	NUT		8
5	23248	CRANKSHAFT	ASSEMBLY	1
6- 1	23250	BEARING	CONNECTING ROD-STD-SET	1
6- 2	23249	BEARING	CONNECTING ROD-010-SET	1
7- 1	23244	BEARING	MAIN-STD-SET	1
7- 2	23243	BEARING	MAIN-010-SET	1
8- 1	23242	WASHER	THRUST-UPPER-STD	2
8- 2	23241	WASHER	THRUST-UPPER-010	2
9- 1	23240	WASHER	THRUST-LOWER-STD	2
9- 2	23239	WASHER	THRUST-LOWER-010	2
10	23247	PUSHING	CRANKSHAFT	1
11	23246	BUSHING		1
12	23245	DOWEL		1
13	14475	GEAR	CRANKSHAFT	1
14	23237	KEY		2
15	14654	SPACER	GEAR	AR 1
16	14598	SLINGER	CRANKSHAFT-FRONT	1
17	23148	PULLEY	CRANKSHAFT	1
18	23235	BOLT	PULLEY TO CRANKSHAFT	1
19	14574	TABWASHER		1
20	23233	DAMPER	VIBRATION	1
21- 1	23232	CAMSHAFT	738B/D101 THRU D460	1
21- 2	24049	CAMSHAFT	738B/D460 ON	1
22	14589	PLATE	CAMSHAFT LOCATING	1
23	14449	GEAR	CAMSHAFT	1
24	14531	KEY	CAMSHAFT GEAR	1
25	14540	NUT	CAMSHAFT GEAR RETAINING	1
26	14544	TABWASHER		1
27	23231	GEAR	IDLER	1
28	23230	CHAIN	TIMING	1
29	23229	TENSIONER	CHAIN	1
30	23228	SHOE	CHAIN TENSIONER	1
31	23227	PIN	STOP-TENSIONER	1
32	23226	CIRCLIP	SHOE TO PIN	1
33- 1	15302	TAPPET	STD	8
33- 2	15303	TAPPET	010	8
33- 3	23225	TAPPET	020	8
34	23224	PUSHROD		8
45	22324	PULLEY	DRIVE SEA WATER PUMP	1
46		CAPSCREW	5/16NF X 3/4 LG	4
48	23997	HUB	IDLER GEAR	1

WESTERBEKE 50 - ROCKER SHAFT

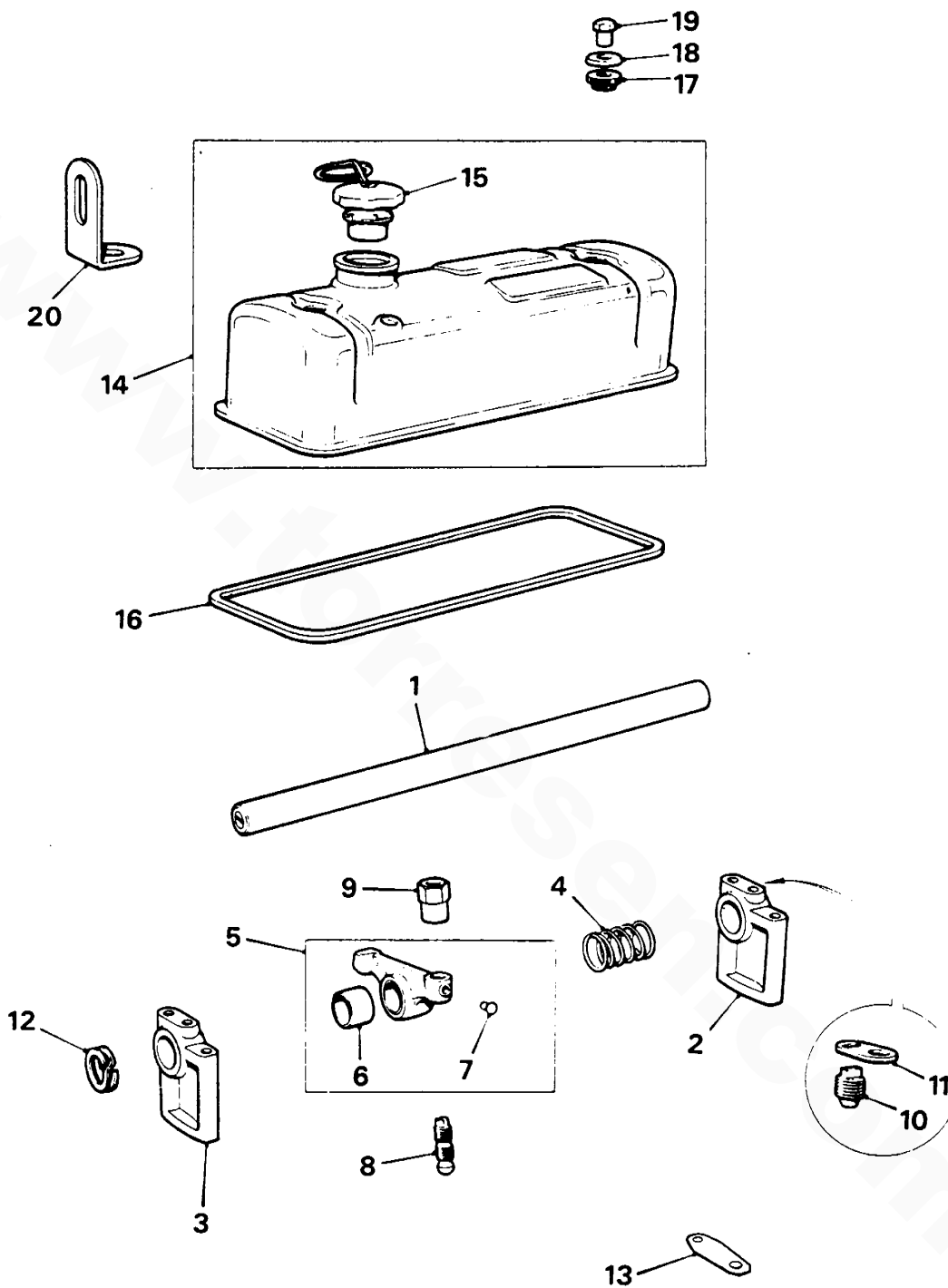

WESTERBEKE 50 - ROCKER SHAFT

REF	PN	NAME	REMARKS	QUAN
1	14438	SHAFT	VALVE ROCKER	1
2	14547	BRACKET	ROCKER SHAFT-TAPPED	1
3	14456	BRACKET	ROCKER SHAFT-PLAIN	3
4	14551	SPRING	ROCKER SHAFT	3
5	14603	ROCKER	ASSEMBLY	8
6	14612	BUSHING	ROCKER	8
7	14625	RIVET	ROCKER	8
8	23208	SCREW	TAPPET ADJUSTING	8
9	14476	NUT	LOCKING	8
10	14481	SCREW	ROCKER SHAFT LOCATING	1
11	14483	PLATE	LOCKING	1
12	14605	WASHER	DOUBLE COIL SPRING	2
13	23207	SHIM	CENTER ROCKER BRACKET	2
14	14479	COVER	ROCKER-VALVE	1
15	17935	CAP	OIL FILL	1
16	14436	GASKET	ROCKER COVER	1
17	14808	GROMMET		2
18	14809	WASHER	CUP-ROCKER COVER	2
19	14807	BUT	CAP	2
20- 1	15299	EYE	LIFTING	2
20- 2	14647	SPACER	WHEN EYE IS REMOVED	2

WESTERBEKE 50 - TIMING COVER

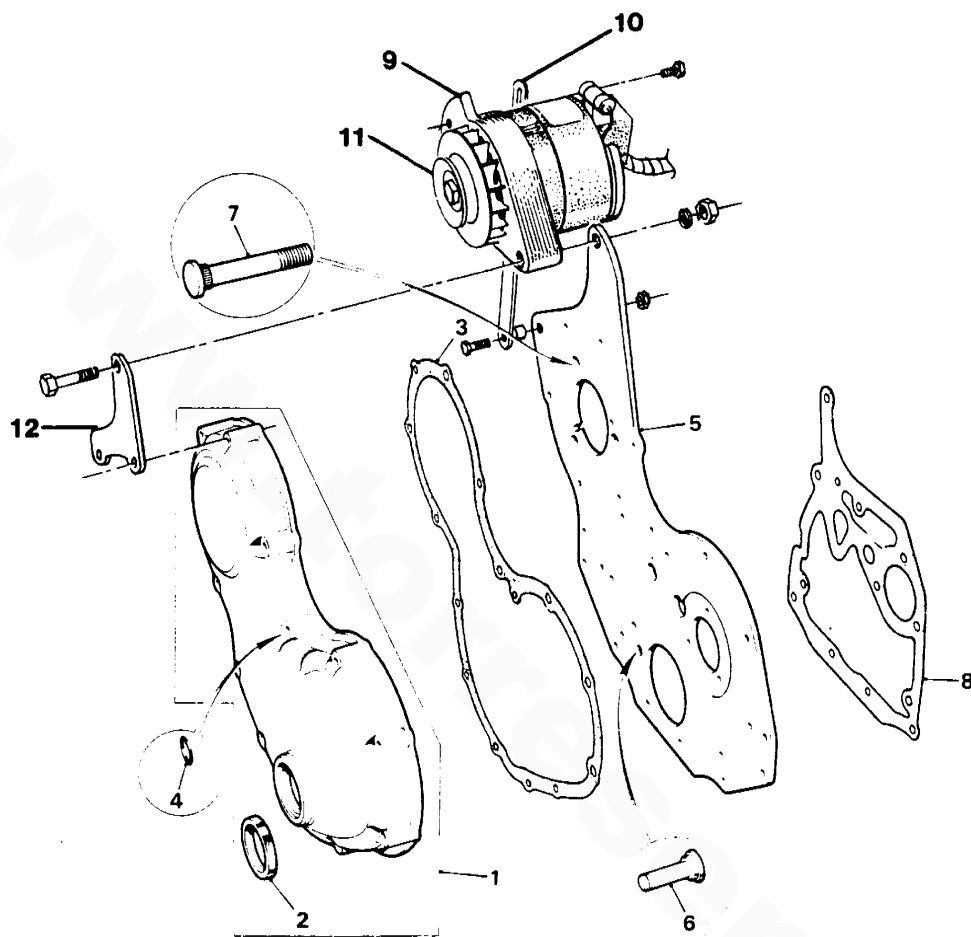

WESTERBEKE 50 - TIMING COVER

REF	PN	NAME	REMARKS	QUAN
1	23197	COVER	FRONT-ASSEMBLY	1
2	14643	SEAL	OIL-FRONT COVER	1
3	23196	GASKET	COVER TO PLATE	1
4	23195	O-RING	COVER TO PLATE BOLT	1
5	23194	PLATE	FRONT	1
6	23193	PIN	TENSIONER SHOE PIVOT	1
7	23192	BOLT	FUEL INJECTION PUMP AND HUB	3
8	23191	GASKET	PLATE TO BLOCK	1
9	19270	ALTERNATOR	55A 12VDC	1
10	11125	STRAP	ALTERNATOR ADJUSTING	1
11	11548	PULLEY	ALTERNATOR	1
12	22919	BRACKET	ALTERNATOR SUPPORT	1

WESTERBEKE 50 - SUMP - LUBE OIL PUMP

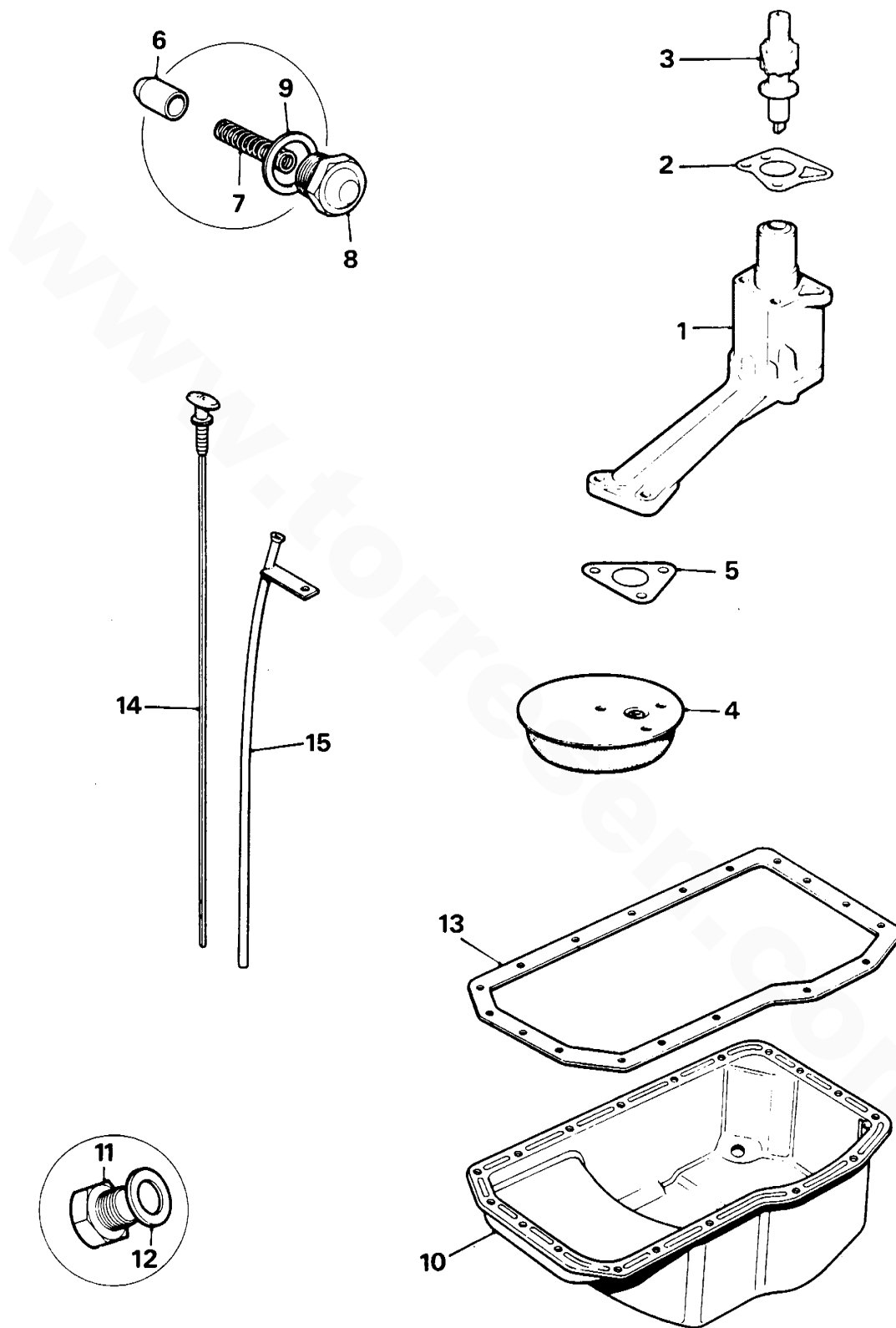

WESTERBEKE 50 - SUMP - LUBE OIL PUMP

REF	PN	NAME	REMARKS	QUAN
1	23206	PUMP	LUBE OIL	1
2- 1	23205	GASKET	PUMP TO CRANKCASE	1
2- 2	14440	WASHER	FLAT	3
2- 3	14497	WASHER	LOCK	3
3	23204	SHAFT	OIL PUMP DRIVING	1
4	14588	STRAINER	OIL PICKUP	1
5	14526	GASKET	STRAINER TO OIL PUMP	1
6	14550	VALVE	OIL RELIEF	1
7	23203	SPRING	OIL RELIEF VALVE	1
8	23202	NUT	CAP-OIL RELIEF VALVE	1
9	14528	WASHER	COPPER	1
10	23150	SUMP	LUBE OIL	1
11- 1	15452	PLUG	DRAIN	1
11- 2	13475	ELBOW		1
11- 3	22927	HOSE	LUBE OIL SUCTION-INCHES REQUIRED	24
11- 4	22929	ADAPTER	HOSE TO ELBOW	1
11- 5	12262	CLAMP	HOSE SUPPORT	2
11- 5	13736	CLAMP	HOSE SUPPORT	2
12	14541	WASHER	DRAIN PLUG	1
13	23200	GASKET	SUMP	1
14	23199	DIPSTICK		1
15	23198	TUBE	DIPSTICK	1
16	14517	WASHER	SUMP TO BLOCK	18

WESTERBEKE 50 - CRANKCASE BREATHER

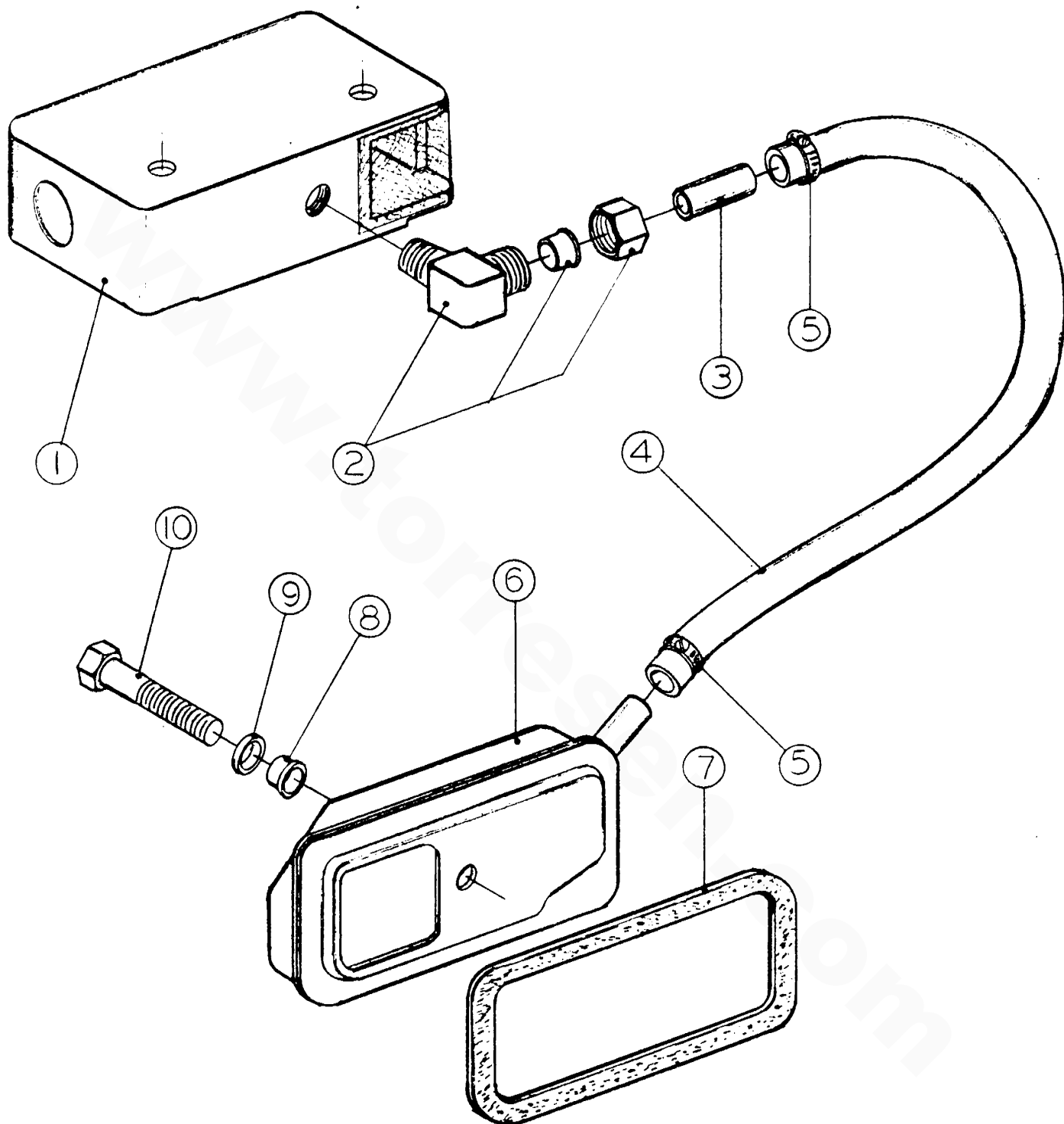



WESTERBEKE 50 - CRANKCASE BREATHER

REF	PN	NAME	REMARKS	QUAN
1	21536	SILENCER	AIR INTAKE	1
2	13335	ELBOW		1
3	16353	TUBING		AR
4	11775	HOSE	1/2 ID	16
5	17298	CLAMP	HOSE	2
6	23362	BREATHER		1
7	23189	GASKET		1
8	14563	BUSHING	RUBBER	1
9	14564	WASHER	CAP	1
10		CAPSCREW	5/16 UNF X 2-1/4 LG	1

www.torresen.com

WESTERBEKE 50 - FUEL SYSTEM

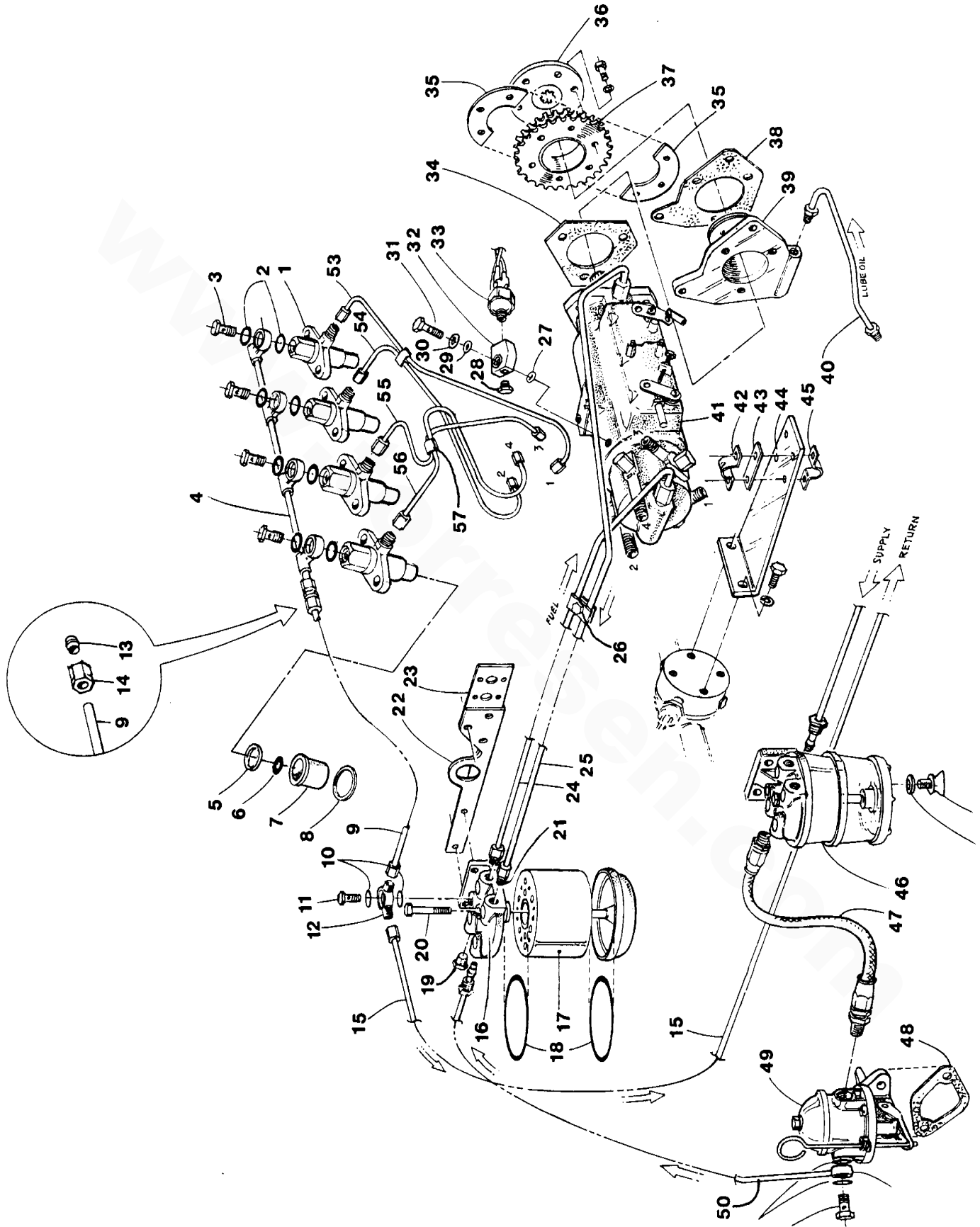

WESTERBEKE 50 - FUEL SYSTEM

REF	PN	NAME	REMARKS	QUAN
1- 1	23182	INJECTOR	ASSEMBLY	4
1- 2	23181	NOZZLE	INJECTOR	4
2	11943	WASHER	BANJO	8
3	11935	BOLT	BANJO	4
4	23844	LINE	INJECTOR RETURN	1
5	14490	WASHER	INJECTOR TO HEAT SHIELD-THICK	4
6	14464	WASHER	INJECTOR SEALING-STEEL	4
7	14462	SHIELD	HEAT	4
8	14463	WASHER	HEAT SHIELD TO HEAD	4
9	11783	TUBING	BUNDY	AR 2
10	11944	WASHER	BANJO	1
11	14663	BOLT	BANJO	1
12	11936	BANJO		1
13	13343	FERRULE	3/16 LINE	2
14	13344	NUT		2
15	20950	HOSE	FUEL RETURN	1
16	14777	FILTER	FUEL-COMPLETE	1
17	14776	ELEMENT	FUEL FILTER INCLUDING O-RINGS	1
18	21918	O-RING	SEAL ELEMENT IN FILTER	2
19- 1	14664	PLUG	FUEL FILTER PORT	1
19- 2	14541	WASHER	PLUG	1
20		BOLT	FILTER CENTER	1
21	14662	VALVE	CHECK	1
22	21739	BRACKET	FILTER MOUNTING	1
23	23919	BRACKET	CIRCUIT BREAKER MOUNT	1
24	23921	LINE	FILTER TO INJECTION PUMP	1
25	23922	LINE	INJECTION PUMP TO FILTER	1
26	23920	CLAMP	FUEL LINE	2
27	19321	O-RING		1
28	11615	PLUG		1
29	19320	O-RING		1
30	19442	WASHER	BANJO BOLT	1
31	19187	BOLT	BANJO	1
32	19185	ADAPTER		1
33	11383	SWITCH	FUEL PRESSURE	1
34	17749	GASKET	PUMP TO HUB	1
35	23184	PLATE	DRIVING FLANGE LOCATING	1
36	23185	FLANGE	DRIVING	1
37	23186	GEAR	DRIVING	1
38	23187	GASKET	HUB TO FRONT PLATE	1
39	23188	HUB	INJECTION PUMP	1
40	23999	LINE	OIL FROM CRANKCASE TO HUB	1
41	23271	PUMP	INJECTION	1
42	13325	CLAMP		1
43	13870	SHIM		1
44	23427	BRACKET	THROTTLE	1
45	13871	CLAMP		1
46	11598	FILTER	PRIMARY FUEL-SEDIMENTER	1

WESTERBEKE 50 - FUEL SYSTEM

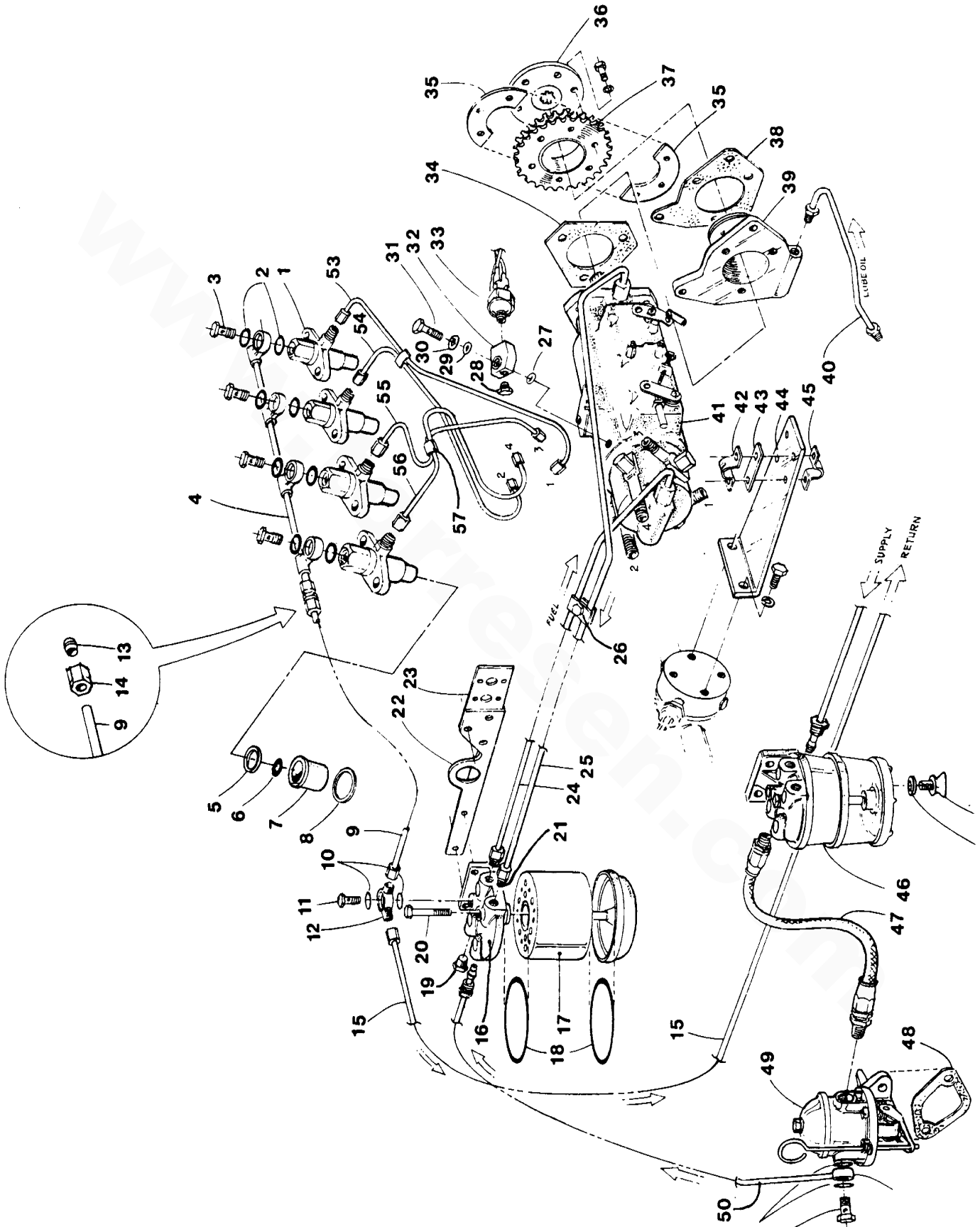

WESTERBEKE 50 - FUEL SYSTEM

REF	PN	NAME	REMARKS	QUAN
47- 1	20938	HOSE	FUEL SUPPLY 18 IN LONG-STD	1
47- 2	23909	HOSE	FUEL SUPPLY 26 IN LONG	1
47- 3	22222	HOSE	FUEL SUPPLY 55 IN LONG	1
48	14572	GASKET	LIFT PUMP TO BLOCK	1
49- 1	14566	PUMP	FUEL LIFT	1
49- 2	14660	KIT	FUEL LIFT PUMP REPAIR-MINOR	1
49- 3	14661	KIT	FUEL LIFT PUMP REPAIR-MAJOR	1
50	23279	LINE	LIFT PUMP TO FILTER	
51	11596	NUT	FOR REF 24,25 & 50	5
52	11597	FERRULE	FOR REF 24,25 & 50	5
53	23273	LINE	INJECTOR 1 HYDRAULIC PUMP	1
54	23274	LINE	INJECTOR 2 HYDRAULIC PUMP	1
55	23275	LINE	INJECTOR 3 HYDRAULIC PUMP	1
56	23276	LINE	INJECTOR 4 HYDRAULIC PUMP	1
57- 1	23277	CLAMP	FUEL LINE	4
57- 2	14493	BUSHING	FUEL LINE TO CLAMP	4

WESTERBEKE 50 - FUEL PRESSURE SWITCH - WATER SEPARATOR

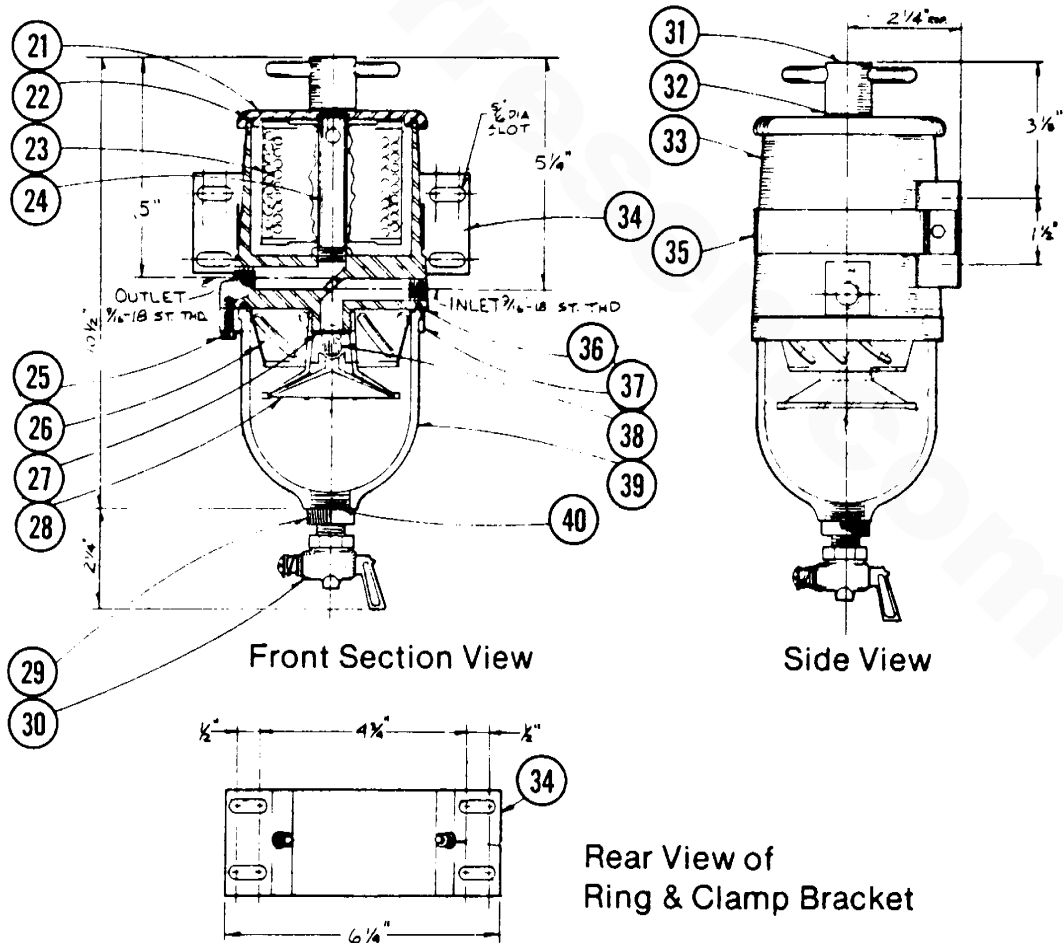
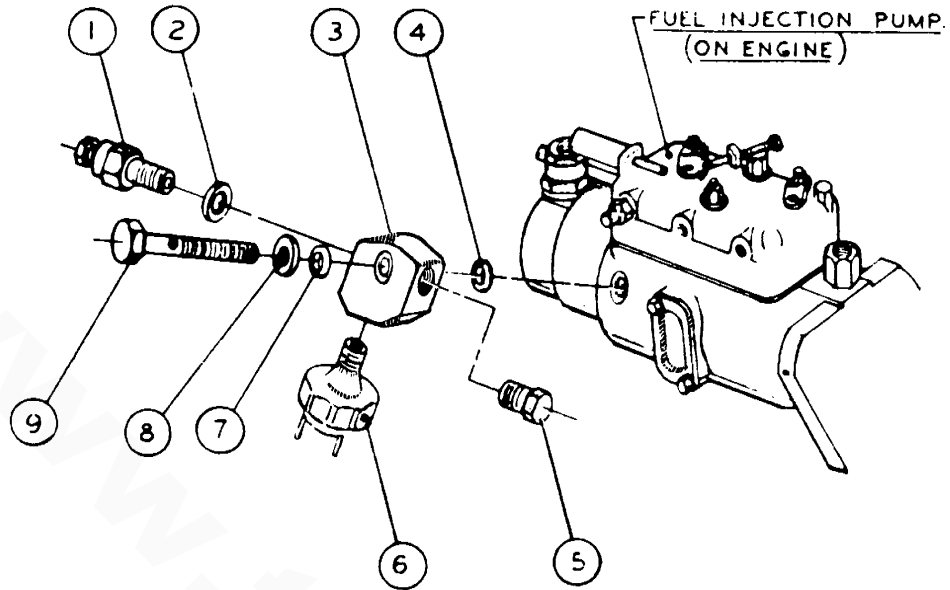

WESTERBEKE 50 - FUEL PRESSURE SWITCH - WATER SEPARATOR

REF	PN	NAME	REMARKS	QUAN
1	19204	SCREW	ASSEMBLY-BLEED	1
2	19261	WASHER	COPPER	1
3	19185	ADAPTER		1
4	19321	O-RING		1
5	11615	PLUG		1
6	11383	SWITCH	FUEL PRESSURE	1
7	19320	O-RING		1
8	19442	WASHER		1
9	19187	SCREW		1
20	22266	SEPARATOR	COMPLETE	1
21	22800	LID		1
22	22275	GASKET	LID	1
23	22258	ELEMENT		1
24	22801	TUBE	RETURN	1
25		SCREWS	10-32	4
26	22802	BAFFLE	CONICAL	1
27	22803	GASKET	CHECK BALL	1
28	22804	CENTRIFUGE		1
29	22622	PLUG	DRAIN BOWL	1
30		PETCOCK	1/4	1
31	22805	HANDLE		1
32	22273	GASKET	NYLON	1
33	22806	HOUSING		1
34	22807	BRACKET	MOUNTING	1
35	22808	CLAMP		1
36	22276	GASKET	BOWL O-RING	1
37	22809	RING	BOWL	1
38	22810	BALL	CHECK	1
39- 1	22277	BOWL		1
39- 2	22269	BOWL	WITH ALARM PROBES	1
40	22274	WASHER	BOWL DRAIN	1
41	22272	SENSOR	KIT FOR ALARM	1

WESTERBEKE 50 - COOLING SYSTEM

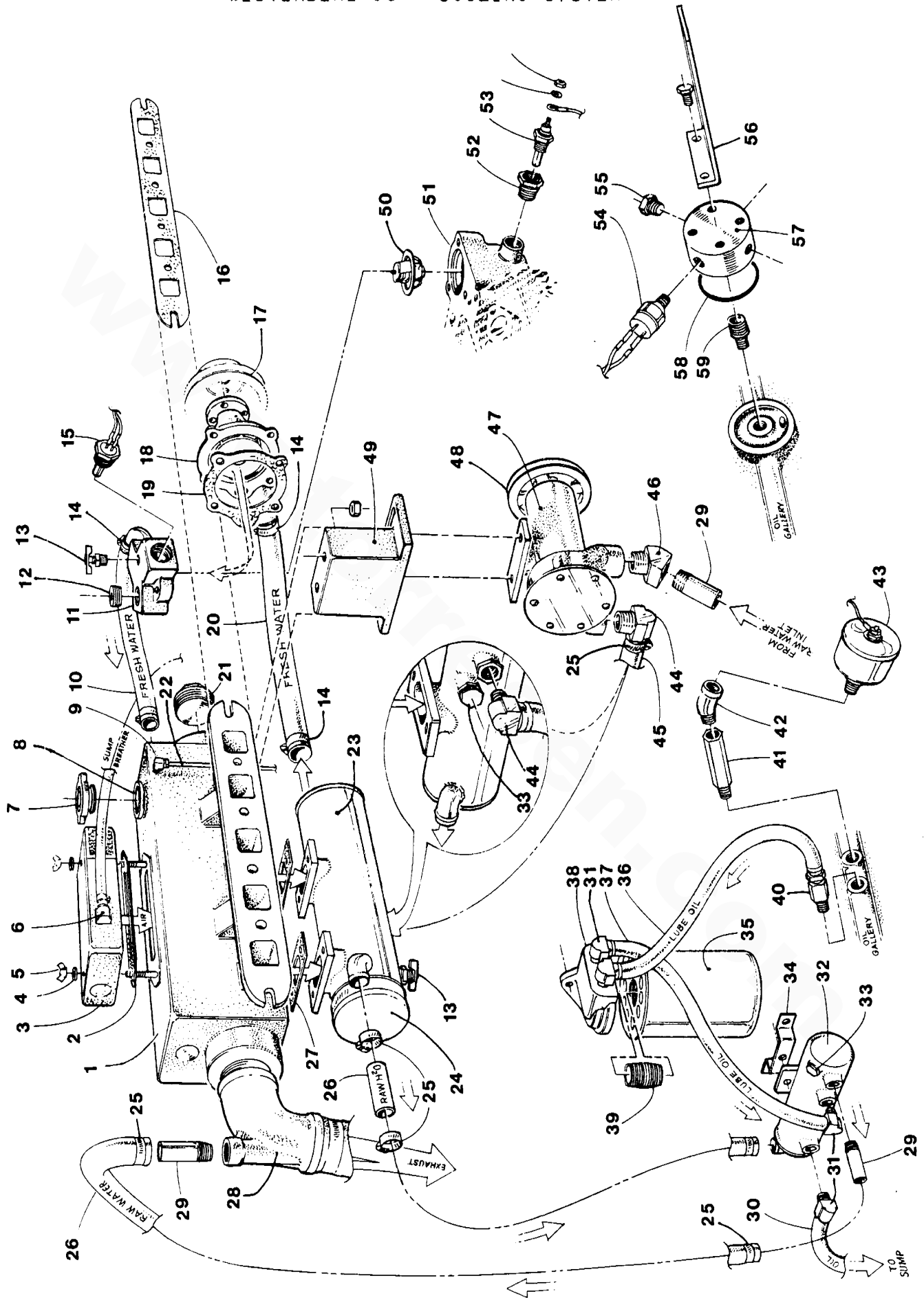



WESTERBEKE 50 - COOLING SYSTEM

REF	PN	NAME	REMARKS	QUAN
1	15784	MANIFOLD		1
2	13680	GASKET	SILENCER TO MANIFOLD	1
3	21536	SILENCER	AIR INTAKE	1
4	13567	WASHER		2
5	16035	WINGNUT		2
6	13335	ELBOW	BREATHER LINE	1
7	11499	CAP	PRESSURE 4PSI	1
8	11751	NECK	FILLER	1
9	13329	ELBOW	WATER OVERFLOW	1
10	21498	HOSE	THERMOSTAT TO MANIFOLD	1
11	15760	HOUSING	THERMOSTAT	1
12	11752	PLUG	THERMOSTAT HOUSING	AR
13	11471	PETCOCK		2
14	21878	CLAMP	HOSE-STAINLESS	4
15	13382	SWITCH	ALARM-WATER TEMPERATURE-OPTIONAL	1
16	11859	GASKET	MANIFOLD TO HEAD	1
17	23178	PULLEY	FRESH WATER PUMP	1
18	23180	PUMP	FRESH WATER	1
19	17888	GASKET	FRESH WATER PUMP TO BLOCK	1
20	13671	HOSE	EXCHANGER TO FRESH WATER PUMP	1
21	19324	PLUG	UNUSED EXHAUST OUTLET IN MANIFOLD	1
22	11500	TURING	WATER OVERFLOW-INCHES REQUIRED	10
23	15799	EXCHANGER	HEAT	1
24	23169	CAP	RUBBER END FOR HEAT EXCHANGER	1
25	11341	CLAMP	HOSE-STAINLESS	6
26	11517	HOSE	INCHES REQUIRED	AR
27	13663	GASKET	EXCHANGER TO MANIFOLD	2
28	15985	ELBOW	WATER INJECTED EXHAUST-90 DEGREE	1
29	13519	NIPPLE	HOSE	5
30	23566	LINE	LUBE OIL COOLER TO CRANKCASE	1
31	13330	ELBOW		4
32	11518	COOLER	LUBE OIL	1
33	11885	ZINC		2
34	23918	BRACKET	OIL COOLER	1
35	16655	ELEMENT	LUBE OIL FILTER	1
36	23561	LINE	BLOCK TO LUBE OIL FILTER	1
37	23566	LINE	LUBE OIL FILTER TO COOLER	1
38	21690	ADAPTER	LUBE OIL FILTER	1
39	13610	NIPPLE	ADAPTER TO ELEMENT	1
40	13348	ADAPTER		1
41	24006	ADAPTER	BLOCK TO OIL PRESSURE SENDER ELBOW	1
42	15122	ELBOW		1
43	11542	SENDER	OIL PRESSURE	1
44	13338	ELBOW		2
45	21516	HOSE	WIRE INSERTED-INCHES REQUIRED	13
46	13337	ELBOW		1
47	11830	PUMP	SEA WATER	1
48- 1	11373	PULLEY	SEA WATER PUMP	1
48- 2	13810	BELT	SEA WATER PUMP DRIVING	1
49	12919	BRACKET	SEA WATER PUMP MOUNTING	1
50	17926	THERMOSTAT		1



WESTERBEKE 50 - COOLING SYSTEM

REF	PN	NAME	REMARKS	QUAN
51	14501	GASKET	THERMOSTAT HOUSING	1
52	23572	BUSHING		1
53- 1	23571	SENDER	WATER TEMPERATURE 1/8NPT	1
53- 2	19369	PLUG	WHEN SENDER NOT INSTALLED	1
54	11552	SWITCH	ALARM-OIL PRESSURE-OPTIONAL	1
55	19369	PLUG		4
56	23427	BRACKET	THROTTLE CABLE	1
57	23913	ADAPTER	OIL FLOW	1
58	20455	O-RING		1
59- 1	23461	NIPPLE	OIL ADAPTER TO BLOCK 738B/D101 THRU D459	1
59- 2	24047	NIPPLE	OIL ADAPTER TO BLOCK 738B/D460 ON	1

www.torresen.com

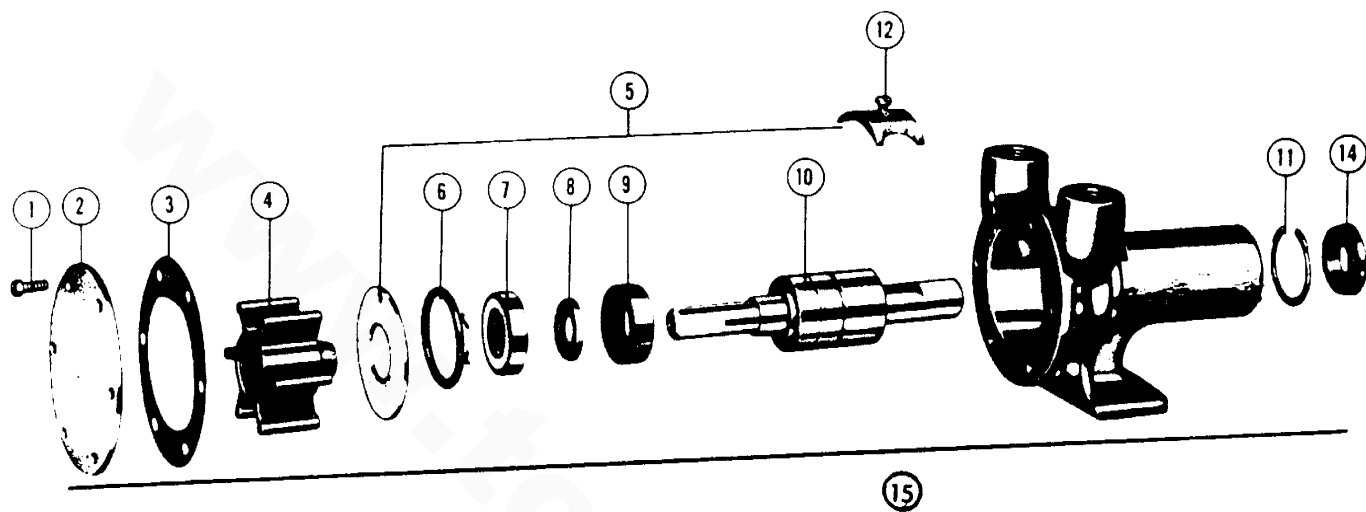

WESTERBEKE 50 - SEA WATER PUMP

REF	PN	NAME	REMARKS	QUAN
1	18188	SCREW	COVER	6
2	18183	COVER		1
3	18182	GASKET	COVER	1
4	18184	IMPELLER		1
5	18186	CAM	INCLUDING WEAR PLATE	1
6	16191	O-RING		1
7	18193	SEAL	SHAFT	1
8	18181	SLINGER		1
9	18194	SEAL	BEARING-INNER	1
10	16185	SHAFT		1
11	18190	SNAPRING		1
12	18189	SCREW	CAM	1
14	16192	SEAL	BEARING-OUTER	1
15- 1	11830	PUMP	COMPLETE	1
15- 2	14768	KIT	IMPELLER AND SEAL REPLACEMENT	1

WESTERBEKE 50 - MOUNTS

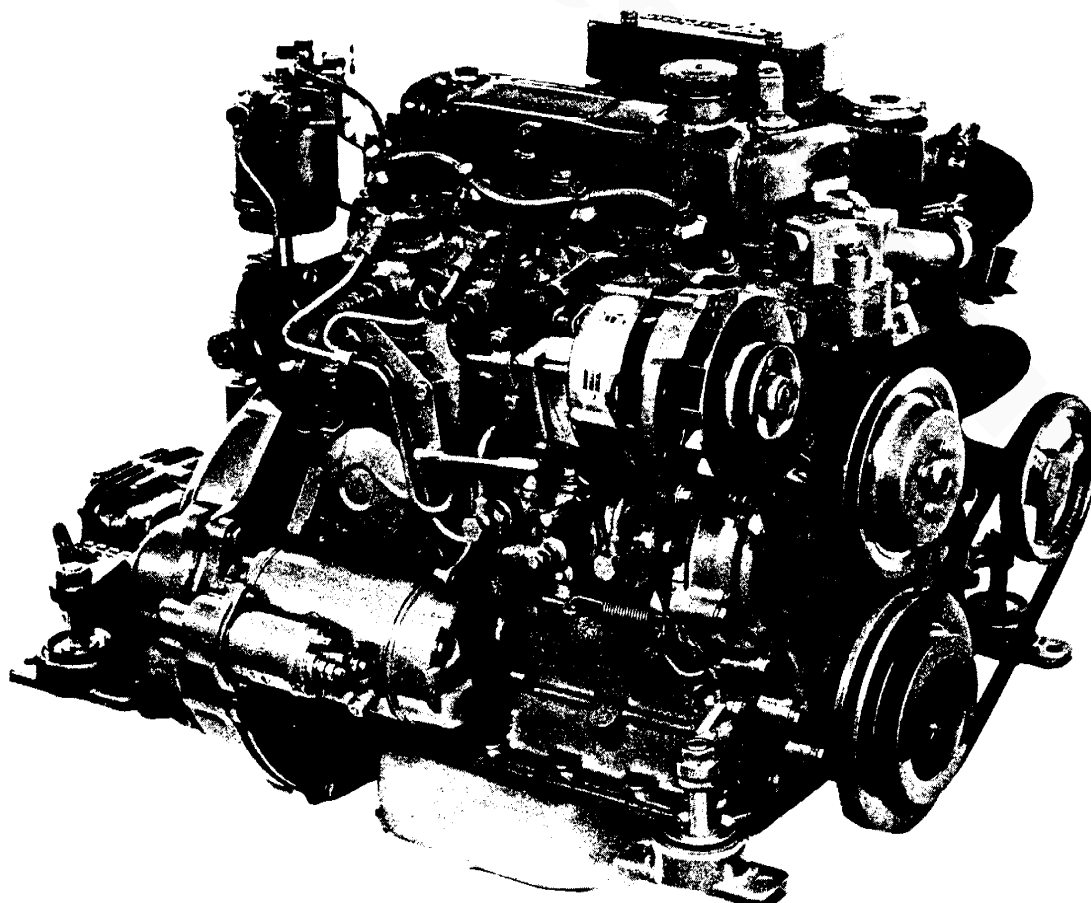
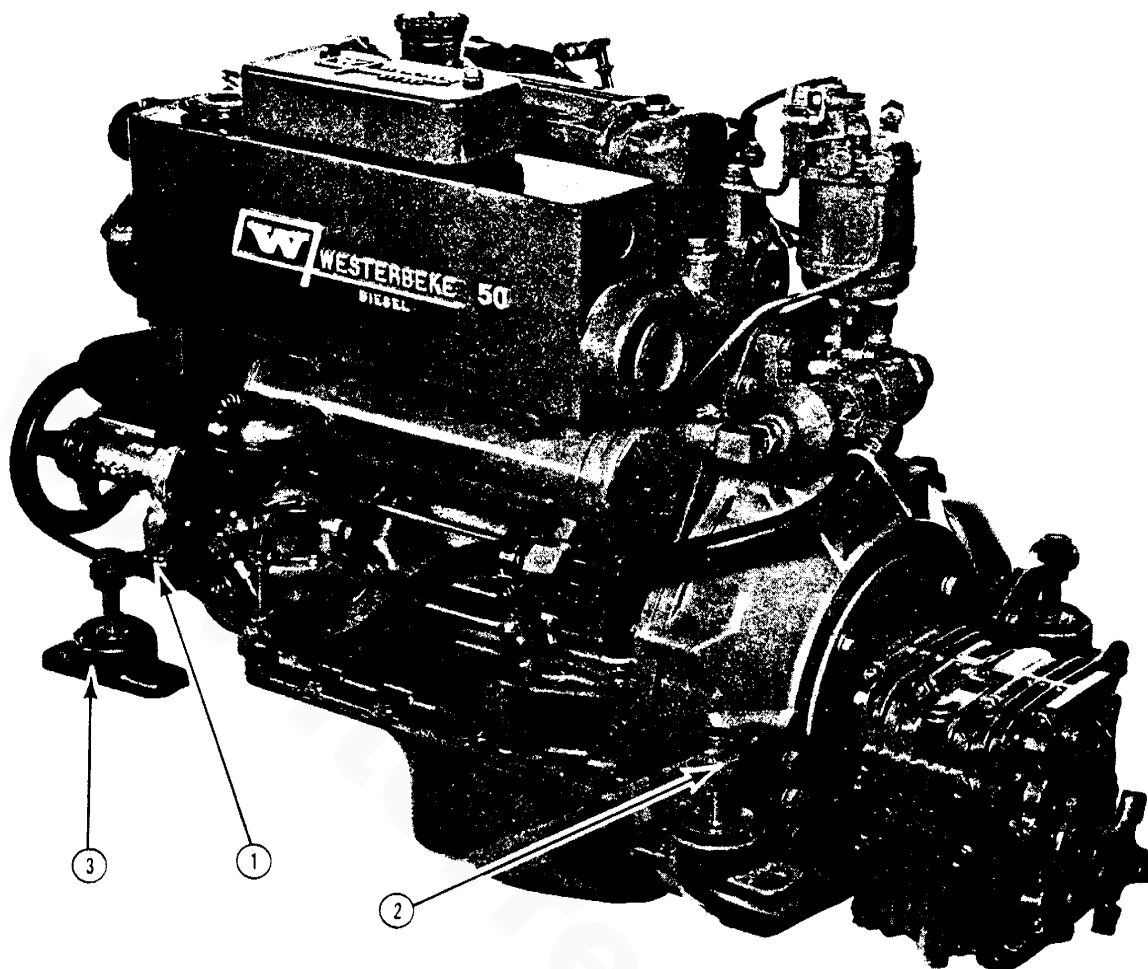

WESTERBEKE 50 - MOUNTS

REF	PN	NAME	REMARKS	QUAN
1	21896	MOUNT	FRONT LEFT & RIGHT-STANDARD	2
2	16040	MOUNT	REAR LEFT & RIGHT-STANDARD	2
3	11687	ISCLATOR		4
4	13470	MOUNT	REAR LEFT 3IN ABOVE CENTER	1
5	23554	MOUNT	REAR RIGHT 3IN ABOVE CENTER	1

www.torresen.com

WESTERBEKE 50 - BACK END

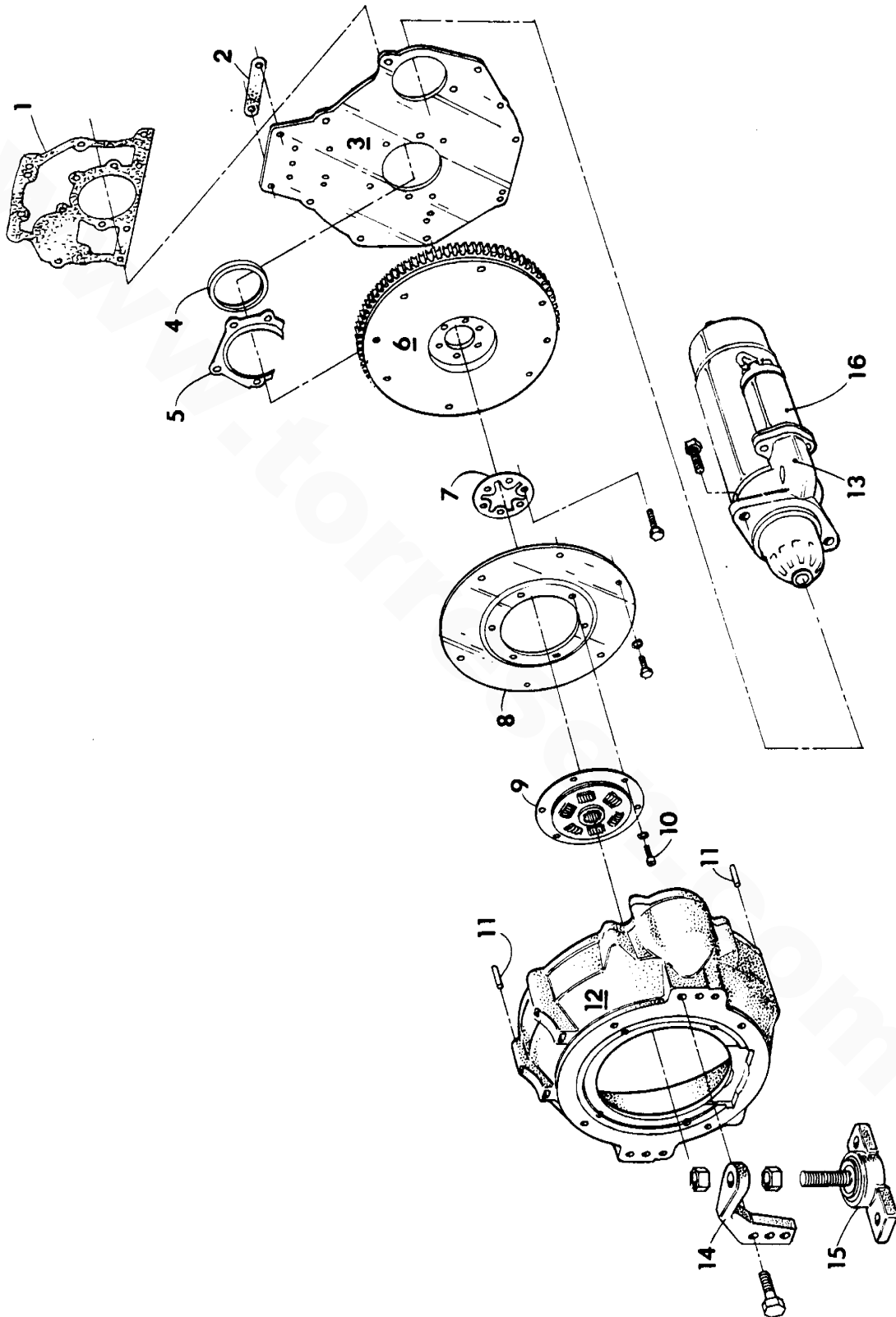



WESTERBEKE 50 - BACK END

REF	PN	NAME	REMARKS	QUAN
1	23175	GASKET	BLOCK TO BACKPLATE	1
2	23174	GASKET	BLOCK TO BACKPLATE-UPPER	1
3	23177	BACKPLATE		1
4	16519	SEAL	OIL	1
5	23173	RETAINER	OIL SEAL TO BACKPLATE	1
6	23172	FLYWHEEL	WITH RING GEAR	1
7	13072	TABWASHER		1
8	18623	ADAPTER	DAMPER TO FLYWHEEL	1
9- 1	19398	DAMPER	SHORT PROFILE SAILING GEAR	1
9- 2	11989	DAMPER	HYDRAULIC GEARS AND SAO MANUAL GEAR	1
10	23779	CAPSCREW	SOCKET HEAD	5
11	23147	DOWEL	HOUSING TO BACKPLATE	2
12	19422	HOUSING	FLYWHEEL	1
13	23122	MOTOR	STARTER INCLUDING SOLENOID	1
14	16040	MOUNT	REAR	2
15	11687	ISOLATOR	REAR	2
16	23942	SOLENOID	STARTER MOTOR	1



ELECTRICAL SYSTEM-MARINE ENGINE-PUSHBUTTON START

REF	PN	NAME	REMARKS	QUAN
1- 1	11581	AMMETER	60-0-60	1
1- 2	21890	AMMETER	100-0-100	1
1- 3	21891	SHUNT	USED WITH 21890 AMMETER	1
1- 4	23636	AMMETER	60-0-60	1
1- 5	23635	SHUNT	USED WITH 23636 AMMETER	1
2	11917	METER	TACHOMETER-HOURMETER	1
3	11544	GAUGE	OIL PRESSURE	1
4	11545	GAUGE	WATER TEMPERATURE	1
6- 1	11957	SWITCH	PUSHBUTTON	2
6- 2	19031	CAP	SWITCH PROTECTIVE COVER	2
9- 1	19270	ALTERNATOR	55 AMP NEG GROUND	1
9- 2	11548	PULLEY	ALTERNATOR DRIVE	1
9- 3	11534	ALTERNATOR	55 AMP 12 VOLT UNGROUNDED	1
9- 4	11125	STRAP	ALTERNATOR ADJUSTING	1
9- 5	22220	BRACKET	ADJUSTING STRAP MOUNTING-W60	1
9- 6	11671	ALTERNATOR	85 AMP NEG GROUND	1
9- 7	11677	ALTERNATOR	120 AMP NEG GROUND	1
9- 8	22219	PULLEY	ALTERNATOR DRIVE 2 GROOVE	1
9- 9	11676	RESISTOR	85-120 AMP ALTERNATOR	1
10- 1	11550	REGULATOR	55 AMP ALTERNATOR	1
10- 2	11682	REGULATOR	85-120 AMP ALTERNATOR	1
10- 3	23088	CABLE	REGULATOR TO ALTERNATOR CABLE	1
11	11383	SWITCH	FUEL - NORMALLY OPEN	1
12	11542	SENDER	OIL PRESSURE	1
13- 1	11543	SENDER	WATER TEMPERATURE 1/4 NPT	1
13- 2	23571	SENDER	WATER TEMPERATURE 1/8 NPT	1
14- 1	14529	GLOWPLUG	W30,W50,W60 AG-32,70 WATT	AR
14- 2	23769	GLOWPLUG	W60 AG-50,95 WATT	AR
14- 3	14494	WIRE	GLOWPLUG CONNECTING 4.25 LONG	AR
16- 1	17959	SOLENOID	START-FOR 17939 STARTER	1
16- 2	23338	SOLENOID	START-FOR 16762 STARTER	1
16- 3	23942	SOLENOID	START-FOR 23122 STARTER	1
17	11552	SWITCH	OIL PRESSURE-NC-OPTIONAL ALARM	1
18	13382	SWITCH	WATER TEMPERATURE-NO-OPTIONAL ALARM	1
19	13355	ALARM	OPTIONAL	1
20- 1	17939	MOTOR	STARTER-W60	1
20- 2	17927	KIT	BRUSH FOR 17939 STARTER	1
20- 3	17947	SPRING	BRUSH FOR 17939 STARTER	1
20- 4	16762	MOTOR	STARTER-W30	1
20- 5	11556	MOTOR	STARTER-FOUR 91-REPLACED BY 16762	1
20- 6	23122	MOTOR	STARTER-W50	1
22	19215	HARNESS	PANEL-GAUGE CONNECTING	2
25- 1	19209	CABLE	INSTRUMENT PANEL FROM ENGINE	1
25- 2	19210	CABLE	INSTRUMENT PANEL 10FT EXTENSION OPTION	1
26	19208	HARNESS	ENGINE PREWIRING	1
27- 1	19206	CABLE	START PANEL FROM ENGINE	1
27- 2	19207	CABLE	START PANEL 10FT EXTENSION OPTION	1
28	12959	KIT	ALTERNATOR MOD FOR ELEC TACHOMETER	1
29- 1	19285	PANEL	INSTRUMENT COMPLETE STANDARD	1
29- 2	22283	PANEL	INSTRUMENT COMPLETE 100AMP	1

ELECTRICAL SYSTEM-MARINE ENGINE-PUSHBUTTON START

WIRING DIAGRAM

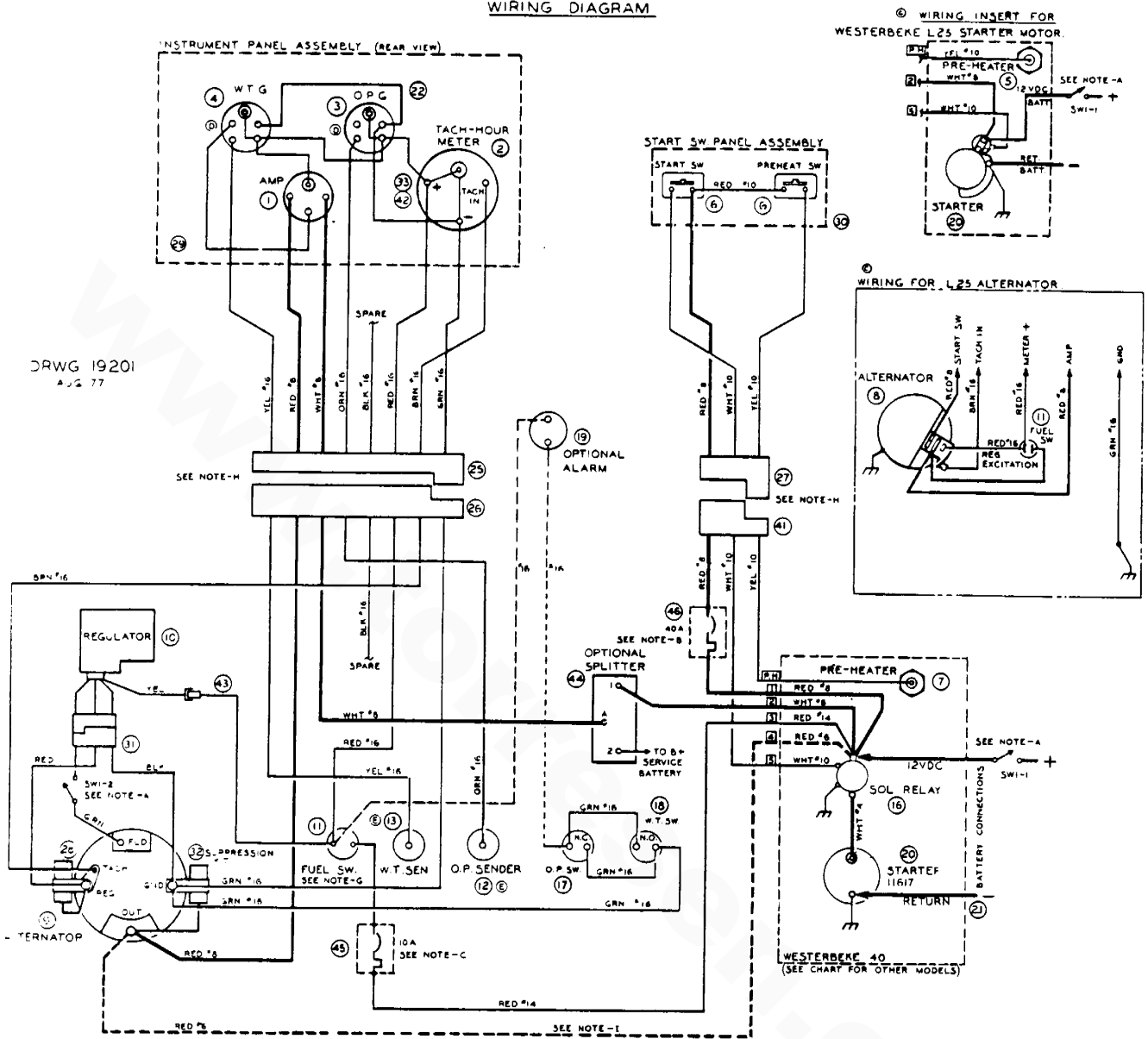

DRWG 19201  
AUG 77

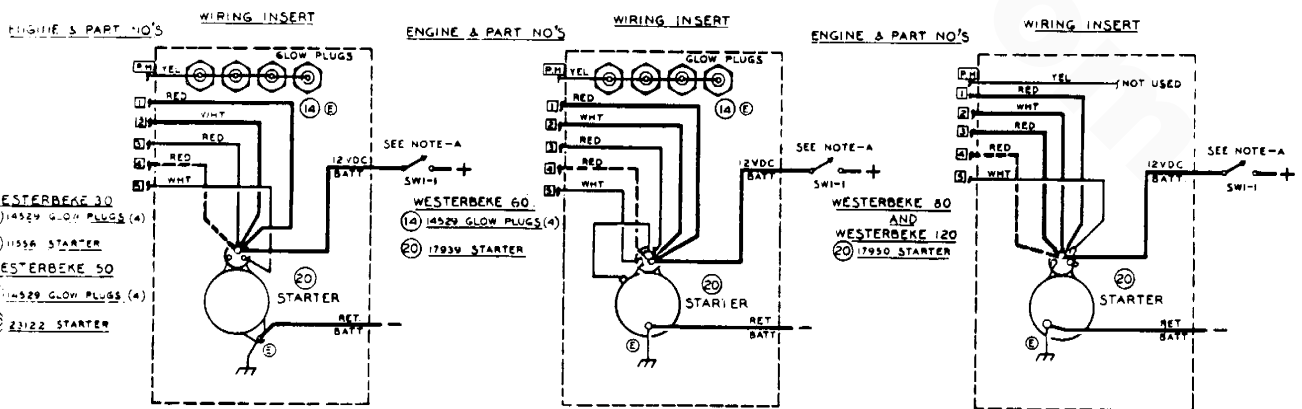

ELECTRICAL SYSTEM-MARINE ENGINE-PUSHBUTTON START

REF	PN	NAME	REMARKS	QUAN
30	19283	PANEL	START-PREHEAT COMPLETE	1
31	11549	CABLE	ALTERNATOR TO REGULATOR	1
32	11532	KIT	SUPPRESSION-ALTERNATOR	1
33	11432	LAMPS	METERS AND GAUGES	4
36- 1	21694	BRACKET	55A PRI ALT MOUNTING-W60	1
36- 2	23012	BRACKET	85-120A PRI ALT MOUNTING-W60	1
36- 3	23014	BRACKET	85-120A PRI ALT MOUNTING-W60	1
36- 4	23480	BRACKET	55A EXTRA ALT MOUNTING-W60	1
37- 1	22030	BELT	PRI ALT DRIVING-W60	1
37- 2	16654	BELT	55A ALT DRIVING-FOUR 154	1
37- 3	15147	BELT	55A ALT DRIVING-W30	1
37- 4	23898	BELT	55A ALT DRIVING-W50	1
41	19205	HARNESS	ENGINE-STARTING	1
42	19216	HOLDER	LAMP	1
43	11670	WIRE	REGULATOR EXCITATION	1
44	20654	SPLITTER	ALTERNATOR OUPUT-OPTION	1
45	20946	BREAKER	CIRCUIT - 10 AMP	1
46	20947	BREAKER	CIRCUIT - 40 AMP	1
70- 1	22251	BRACKET	CIRCUIT BREAKER MOUNTING-W60	1
70- 2	12976	BRACKET	REGULATOR & CIRCUIT BREAKER MOUNTING	1
70- 3	23919	BRACKET	CIRCUIT BREAKER MOUNTING-W50	1
71	11969	MANIFOLD	OIL PRESSURE FOR OPTIONAL SWITCHES	1
72	11981	HOSE	BLOCK TO OIL PRESSURE MANIFOLD	1

WESTERBEKE 50 - SHORT PROFILE SAILING GEAR-MODEL 10

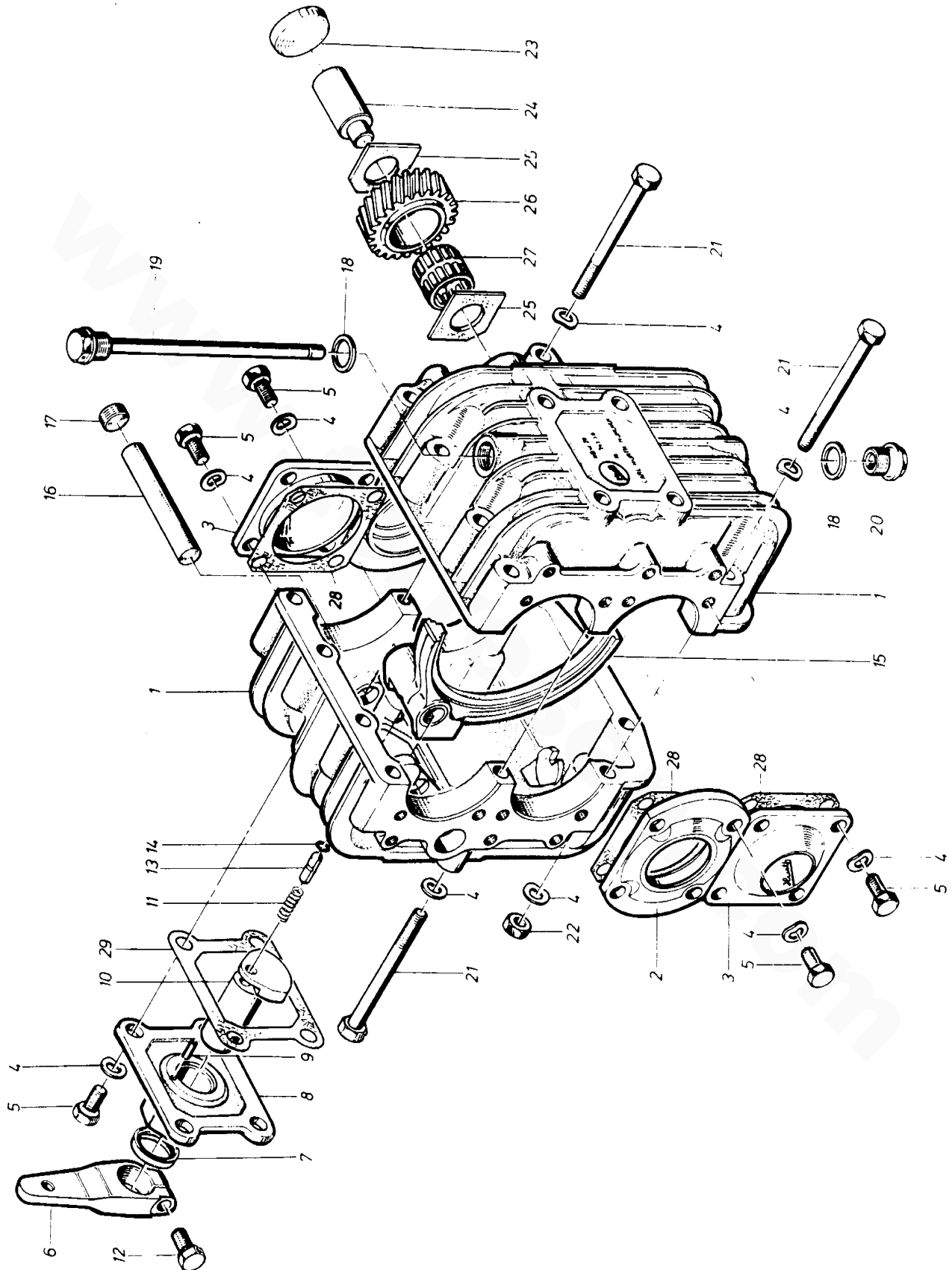

WESTERBEKE 50 - SHORT PROFILE SAILING GEAR-MODEL 10

REF	PN	NAME	REMARKS	QUAN
1	22139	HOUSING	ASSEMBLY	1
2	22179	COVER		2
3	22200	COVER		2
4	22209	WASHER	SPRING M8 DIN 137 VCAD	38
5	22208	CAPSCREW	M8X16 DIN 933 VCAD	20
6	22191	LEVER	SHIFTING	1
7	22195	SEAL	RING	1
8- 1	22188	COVER	SHIFTING CONTROL ASSEMBLY-REF 6 THRU 14	1
8- 2	22189	COVER		1
9	22196	SLEEVE	ADJUSTING	1
10	22190	CAM	CONTROL	1
11	22170	SPRING	PRESSURE	1
12	22193	CAPSCREW	M8X20 DIN 933 VCAD	1
13	22192	PIN	STOPPING	1
14	22194	RING	SEMI-CIRCULAR	1
15	22140	FORK	SHIFTING ASSEMBLY	1
16	22141	ROD	SHIFTING	1
17	22147	PLUG		1
18	22210	SEAL	RING	2
19	22197	DIPSTICK	VENT ASSEMBLY	1
20	22205	SCREW	LOCKING	1
21	22211	CAPSCREW	M8X90 DIN 931 VCAD	10
22	22206	NUT	HEX M8 DIN 934 VCAD	8
23	22146	O-RING		1
24	22142	SHAFT	GEAR, INTERMEDIATE	1
25	23486	DISC	STARTING	2
26	22143	GEAR	INTERMEDIATE, TEETH-25	1
27	22145	BEARING	NEEDLE TWIN CAGE	1
28	22187	GASKET		4
29	22207	GASKET		1
30	22199	SEAL	RING	1
31	22186	BEARING	TAPER, ROLLER ASRG	4
32	22150	BEARING	TAPER, ROLLER INTL	4
33	22149	SHAFT	INPUT, TEETH-22/22	1
34	22201	WASHER	0.1 MM	2
35	22202	WASHER	0.2 MM	2
36	22203	WASHER	0.5 MM	2
37	22204	WASHER	1.0 MM	2
38	23508	NUT	GROOVED	1
39	22185	DISC	FITTING	1
40	22181	DISC		2
41	22167	GEAR	TEETH-47	1
42	22165	BEARING	NEEDLE CAGE	2
43	22156	RING	NEEDLE BEARING	2
44	22157	SPACER		2
45	22154	SPRING	CUP	4
46	22155	DISC	PRESSURE	2
47	22164	RING	SNAP	2
48	22162	SHEET	STRIP, LAMINARY, INNER	8
49	22163	SHEET	STRIP, LAMINARY, OUTER	6

WESTERBEKE 50 - SHORT PROFILE SAILING GEAR-MODEL 10

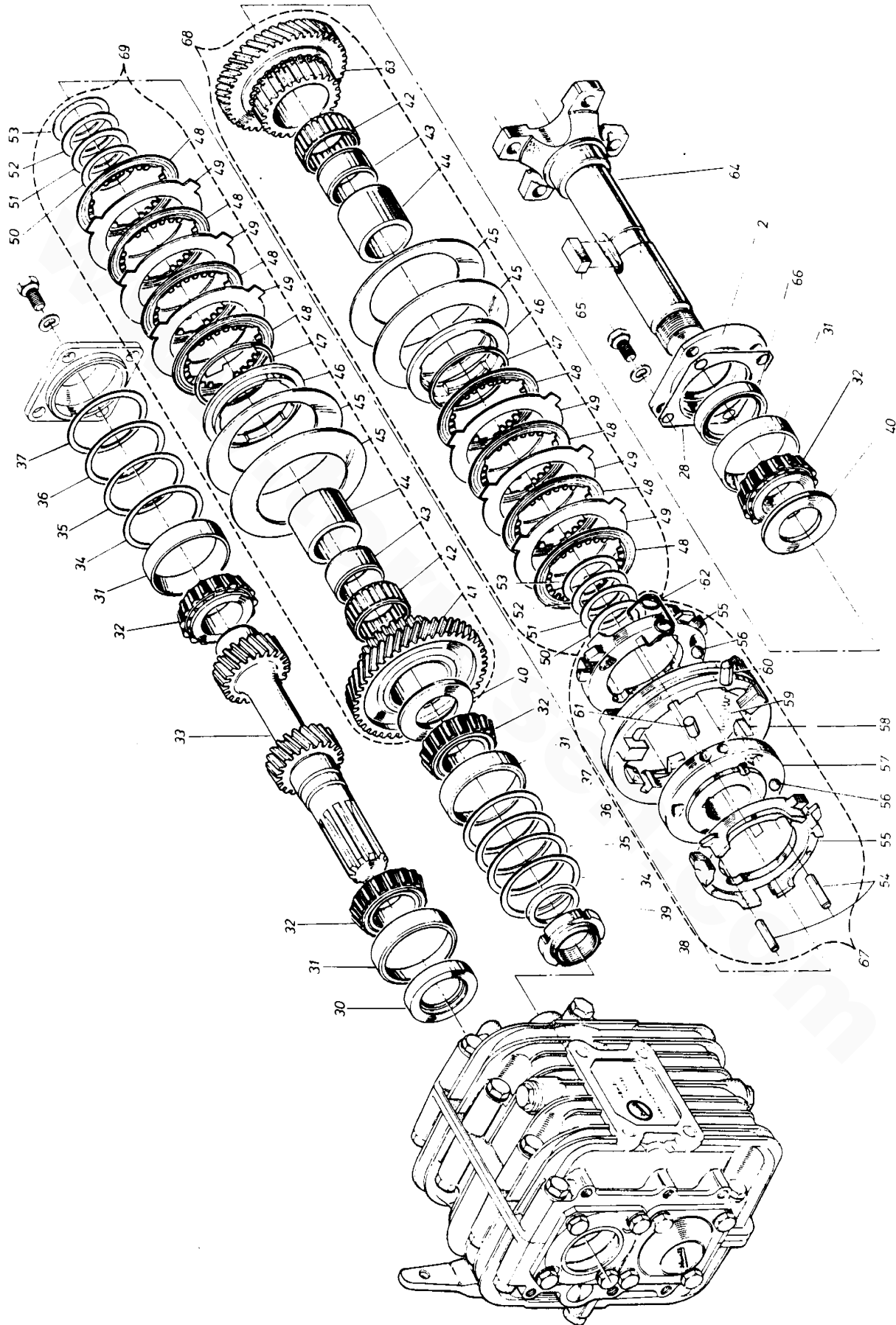



WESTERBEKE 50 - SHORT PROFILE SAILING GEAR-MODEL 10

REF	PN	NAME	REMARKS	QUAN
50	22158	WASHER	0.4 MM	2
51	22159	WASHER	0.5 MM	2
52	22160	WASHER	0.6 MM	2
53	22161	WASHER	0.7 MM	2
54	22172	PIN		2
55	22177	CARRIER	STRIP SHEET	2
56	22169	BALL		6
57	22174	SOCKET	GUIDE	1
58	22176	SOCKET	CONTROL	1
59	22170	SPRING	PRESSURE	3
60	22171	PIN	STOPPING	3
61	22173	PIN	DRIVING	3
62	22175	SPRING	TORSION	3
63	22153	GEAR	TEETH-43	1
64	22182	SHAFT	OUTPUT	1
65	22183	KEY	FITTING	1
66	22180	SEAL	RING	1
67	22168	SHIFTING	ASSEMBLY-REF 54 THRU 62	1
68	22152	GEAR	ASSEMBLY-43 TEETH	1
69	22166	GEAR	ASSEMBLY-47 TEETH	1
70	22151	SHAFT	OUTPUT-COMPLETE ASSEMBLY	1
80	18360	GEAR	COMPLETE TRANSMISSION 2 TO 1	1
90- 1	23679	COUPLING	BORED 3/4	1
90- 2	23680	COUPLING	BORED 7/8	1
90- 3	23681	COUPLING	BORED 1	1
90- 4	23682	COUPLING	BORED 1-1/8	1
90- 5	23683	COUPLING	BORED 1-1/4	1
90- 6	23684	COUPLING	BORED 1-3/8	1
90- 7	23685	COUPLING	BORED 1-1/2	1
91- 1	23450	SCREW	COUPLING-23679,23680 & 23685	2
91- 2	23652	SCREW	COUPLING-23681 & 23682	2
91- 3	23651	SCREW	COUPLING-23683 & 23684	2
95- 1	23449	KIT	SHIFTING BRACKET	1
95- 2	22322	BRACKET		1
95- 3	13325	CLAMP		1
95- 4	13870	SHIM		1
95- 5	19364	BALL JOINT		1
95- 6	13630	CAPSCREW	M8 X 25	2

WESTERBEKE 50 - TYPE SAO MANUAL TRANSMISSION

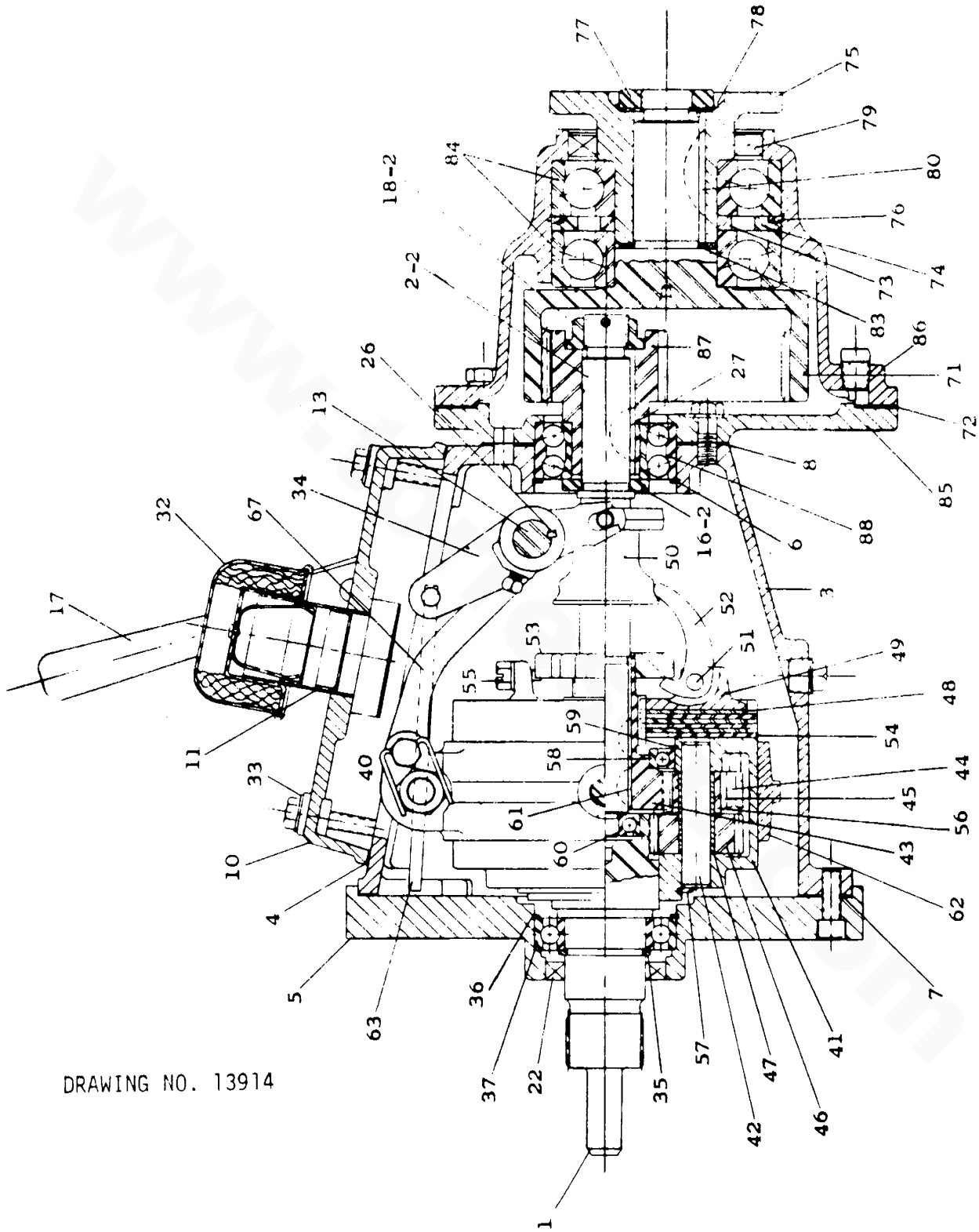

DRAWING NO. 13914

WESTERBEKE 50 - TYPE SAO MANUAL TRANSMISSION

REF	PN	NAME	REMARKS	QUAN
1	14894	GEAR	ENGINE	1
2- 1	14857	TAILSHAFT	REVERSE GEAR	1
2- 2	14858	TAILSHAFT	REVERSE GEAR	1
2- 3	14899	TAILSHAFT		1
3	14891	HOUSING	REVERSE GEAR	1
4	14868	GASKET	HAND HOLE COVER	1
5	14892	PLATE	FRONT END	1
6	14373	RING	RETAINING-REVERSE GEAR HOUSING	1
7	14893	GASKET	REVERSE GEAR HOUSING-FRONT	1
8	14876	GASKET	REAR-REVERSE GEAR HOUSING	1
9	14895	DIPSTICK	ASSEMBLY	1
10	14867	COVER	HAND HOLE	1
11	14883	TUBE	FILLER	1
12	14879	PIN	BRAKE BAND LOCK	1
13	14861	SHAFT	CROSS	1
14	14863	COUPLING	GEAR HALF	1
15	14864	RETAINER	OIL SEAL	1
16- 1	14865	WASHER	THRUST REVERSE GEAR TAILSHAFT	1
16- 2	14866	WASHER	THRUST REVERSE GEAR TAILSHAFT	1
17	14852	LEVER		1
18- 1	14377	NUT	REVERSE GEAR TAILSHAFT	1
18- 2	14323	NUT	REVERSE GEAR TAILSHAFT	1
19	14875	LOCKWASHER	REVERSE GEAR TAILSHAFT	1
20	14884	SEAL	OIL-CROSS SHAFT	1
21	14885	RETAINER	OIL SEAL	1
22	14896	SEAL	FRONT PLATE	1
23	14886	O-RING		1
24	14887	PIN	ROLL	1
25	14882	BEARING	BALL-REVERSE GEAR HOUSING-REAR	1
26	14316	KEY	WOODRUFF-CROSS SHAFT	1
27	14848	KEY	WOODRUFF-REVERSE GEAR TAILSHAFT	1
32	14880	BREATHER		1
33	14888	SEAL	COVER	1
34	14862	YOKE	ASSEMBLY	1
35	14903	RING	RETAINING-ENGINE GEAR	1
36	14897	RING	RETAINER-FRONT PLATE	1
37	14898	BEARING	BALL-ENGINE GEAR	1
38	14889	TUBE	DIPSTICK	1
40	14890	BAFFLE	COVER	1
41	14834	CASE	GEAR	1
42	14842	SHAFT	PINION	1
43	14836	GEAR	PROPELLER	1
44	14837	PINION	ASSEMBLY-LONG	1
45	14840	BUSHING	PINION	1
46	14838	PINION	ASSEMBLY-SHORT	1
47	14841	BUSHING	PINION	1
48	14845	PLATE	STEEL-CLUTCH	1
49	14846	PLATE	PRESSURE	1
50	14847	SLEEVE	OPERATING	1
51	14849	PIN	FINGER	1
52	14851	FINGER		1
53	14854	SCREW	COLLAR	1
54	14855	PLATE	BRONZE-CLUTCH	1
55	14859	LOCKSCREW	PRESSURE PLATE	1

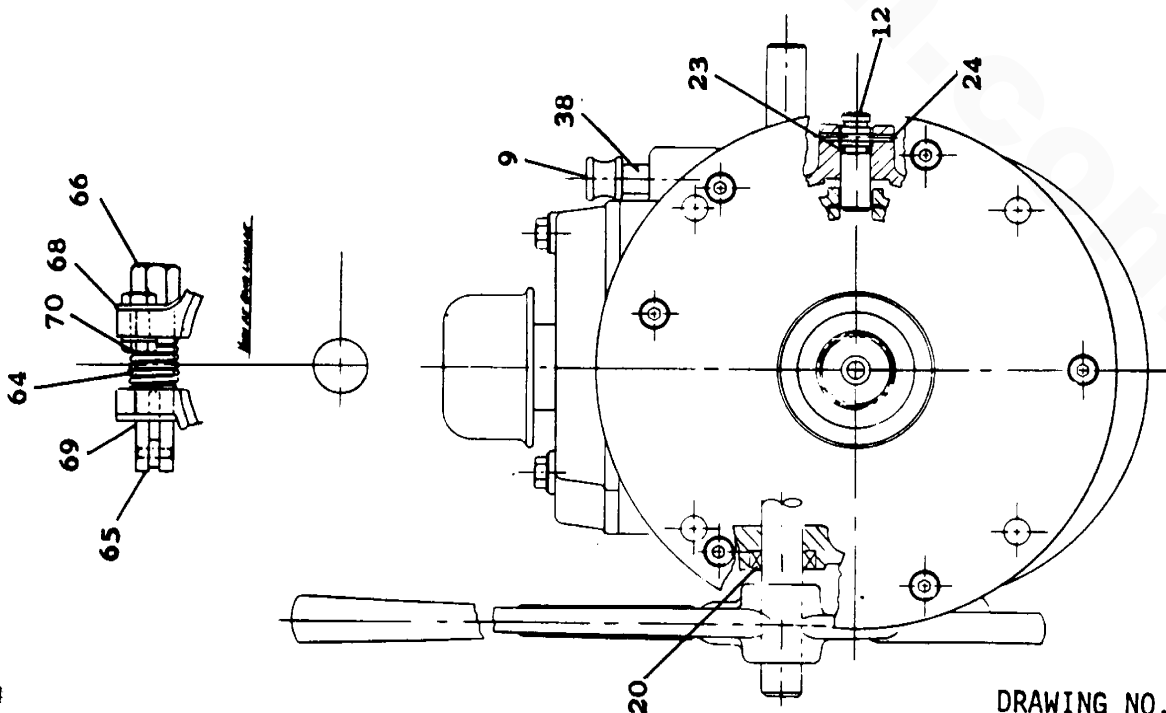

MINOR DIMENSIONS

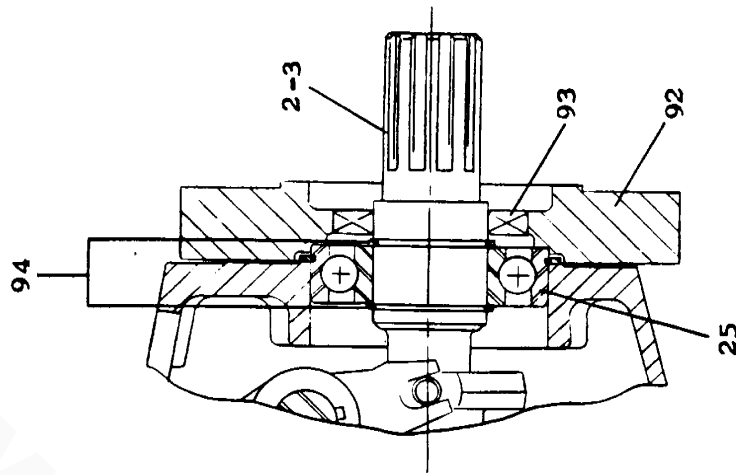

DIRECT DRIVE FOR WALTER'S "Y" DRIVE

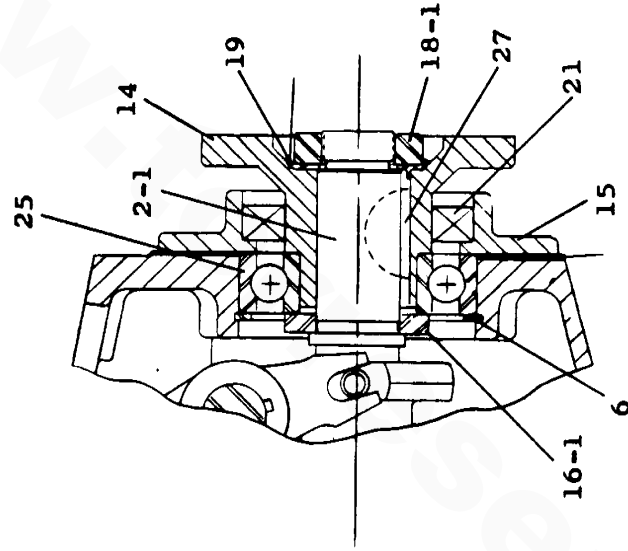

DIRECT DRIVE SAOD

WESTERBEKE 50 - TYPE SAO MANUAL TRANSMISSION

REF	PN	NAME	REMARKS	QUAN
56	14871	SPACER	SHORT PINION	1
57	14874	RING	RETAINING-PINION SHAFT GEAR CASE	1
58	14877	BEARING	BALL-GEAR CASE	1
59	14373	RING	RETAINING-GEAR CASE BALL BEARING	1
60	14881	BEARING	BALL-PILOT	1
61	14844	KEY	WOODRUFF-REVERSE GEAR-TAILSHAFT	1
62	14850	BAND	BRAKE	1
63	14860	SLIDE	REVERSE CAM	1
64	14870	SPRING		1
65	14853	CAM	REVERSE	1
66	14856	NUT		1
67	14869	BRACE		1
68	14872	LOCKSPRING		1
69	14878	PIN		1
70	14873	NUT		1
71	14299	GEAR	INTERNAL	1
72	14321	GASKET		1
73	14333	SPACER		1
74	14337	SPACER		1
75	14357	COUPLING		1
76	14375	SNAPRING		1
77	14378	NUT		1
78	14379	LOCKWASHER		1
79	14390	SEAL	OIL	1
80	14352	KEY		1
83	14334	SEAL	WASHER	1
84	14396	BEARING	BALL	2
85	14835	PLATE	REDUCTION ADAPTER	1
86- 1	14309	HOUSING	REDUCTION GEAR	1
86- 2	14904	REDUCTION	COMPLETE UNIT-2 1	1
87	14839	GEAR	REDUCTION DRIVING	1
88	14843	BEARING	BALL-REDUCTION ADAPTER PLATE	1
92	14900	PLATE	ADAPTER	1
93	14901	SEAL	OIL	1
94	14902	RINGS	RETAINING-TAILSHAFT	2
95- 1	12293	GEAR	COMPLETE TRANSMISSION 1 TO 1	1
95- 2	20441	GEAR	COMPLETE TRANSMISSION 1.5 TO 1	1
95- 3	12294	GEAR	COMPLETE TRANSMISSION 2 TO 1	1
95- 4	16246	GEAR	COMPLETE TRANSMISSION 2 TO 1 DROP	1
95- 5	20518	GEAR	COMPLETE TRANSMISSION 2.5 TO 1	1
95- 6	13976	GEAR	COMPLETE TRANSMISSION TO ACCEPT V-DRIVE	1
96- 1	23654	COUPLING	TRX 12293 BORED 3/4	1
96- 2	23655	COUPLING	TRX 12293 BORED 7/8	1
96- 3	23656	COUPLING	TRX 12293 BORED 1	1
96- 4	23657	COUPLING	TRX 12293 BORED 1-1/8	1
96- 5	23660	COUPLING	REDUCTION TRX BORED 3/4	1
96- 6	23661	COUPLING	REDUCTION TRX BORED 7/8	1
96- 7	23662	COUPLING	REDUCTION TRX BORED 1	1
96- 8	23663	COUPLING	REDUCTION TRX BORED 1-1/8	1
96- 9	23664	COUPLING	REDUCTION TRX BORED 1-1/4	1
96-10	23665	COUPLING	REDUCTION TRX BORED 1-3/8	1
97- 1	23450	SCREW	COUPLING 23660 THRU 23665	2
97- 2	22326	SCREW	COUPLING 23654 THRU 23657 3/8UNC	1

NOTE-SOME COUPLINGS USE 3/8UNF SCREWS

WESTERBEKE 50 - MISCELLANEOUS

REF	PN	NAME	REMARKS	QUAN
1- 1	23563	KIT A	SPARE PARTS	1
1- 2	23564	KIT B	SPARE PARTS-EXTENDED CRUISING	1
2- 1	23072	GASKET	SET-UPPER	1
2- 2	23078	GASKET	SET-LOWER	1
3	11592	PUMP	HAND-TO PUMP LUBE OIL FROM SUMP	1
4- 1	21501	FILTER	PRIMARY FUEL	1
4- 2	22266	SEPARATOR	WATER-FUEL	1
5	13174	MUFFLER	HYDRO-HUSH WATER LIFT	1
6	15010	STRAINER	SEA WATER	1
7	16506	TANK	REMOTE FRESH WATER SURGE	1
8- 1	17232	KIT	MORSE CABLE CONNECTING-PARAGON HYDRAULIC	1
8- 2	17252	KIT	MORSE CABLE CONNECTION-WARNER HYDRAULIC	1
9	20654	SPLITTER	ALTERNATOR OUTPUT TO 2 BATTERIES	1
10- 1	23309	SWITCH	NEUTRAL SAFETY-PARAGON HYDRAULIC	1
10- 2	23433	SWITCH	NEUTRAL SAFETY-WARNER HYDRAULIC	1
11	13758	PAINT	RED-AEROSOL SPRAY CAN	1
12	12169	LINE	FLEXIBLE EXHAUST 1-1/2 X 12	1
13	15985	ELBOW	WATER INJECTED EXHAUST-90 DEGREE	1
14- 1	23986	PULLEY	MODIFICATION TO ALLOW ACCESSORY PULLEYS	1
14- 2	23792	PULLEY	ACCESSORY CRANKSHAFT 2 GROOVE 5IN	1
14- 3	23790	PULLEY	ACCESSORY CRANKSHAFT 2 GROOVE 6IN	1
14- 4	23784	PULLEY	ACCESSORY CRANKSHAFT 2 GROOVE 7IN	1
15	21513	FILTER	REMOTE LUBE OIL	1

[www.torresen.com](http://www.torresen.com)