

# TECHNICAL MANUAL

## WESTERBEKE 58

Marine Diesel Engine

## WESTERBEKE

20.0 YD - 60 Hz

20.0 WTA - 60 Hz

16.0 WTA - 50 Hz

Marine Diesel Generators

Publication # 24331

Edition Three

November 1990



# TECHNICAL MANUAL

## WESTERBEKE 58

Marine Diesel Engine

## WESTERBEKE

20.0 YD - 60 Hz

20.0 WTA - 60 Hz

16.0 WTA - 50 Hz

Marine Diesel Generators

Publication # 24331

Edition Three

November 1990



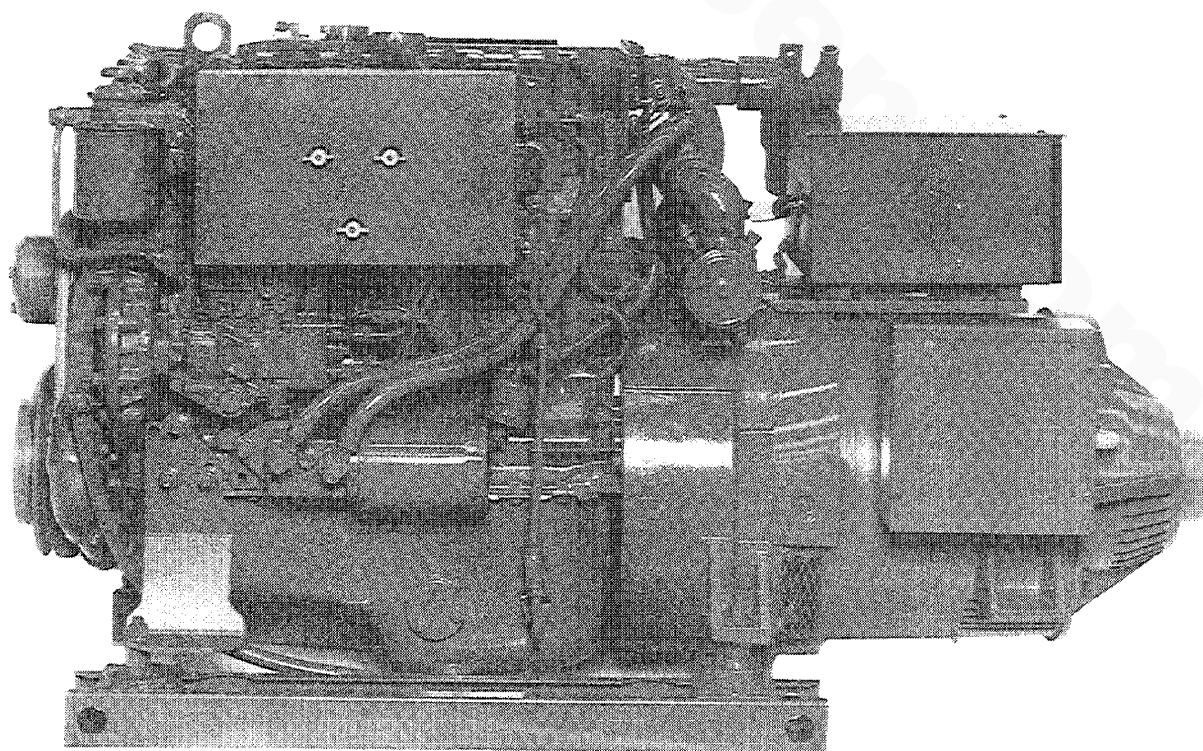
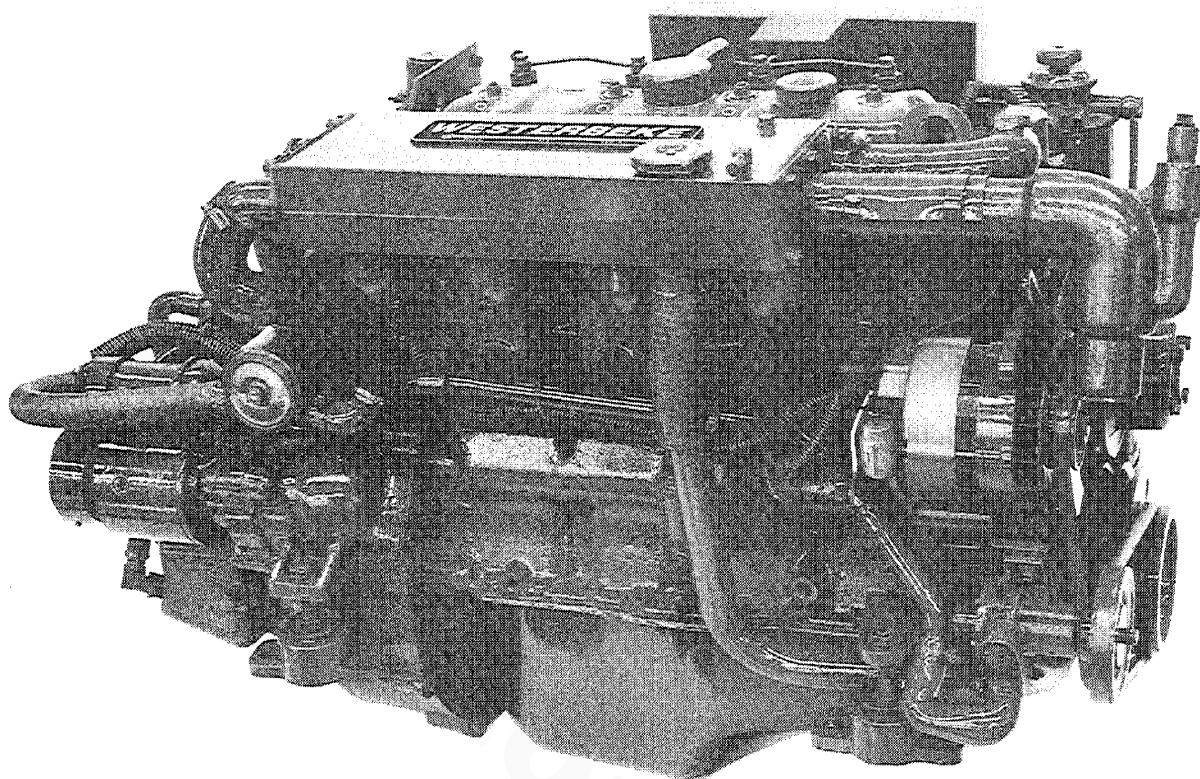

# **SECTION INDEX**

## **GENERAL**

Introduction	Operation
Installation	Maintenance

## **ENGINE OVERHAUL**

## **OTHER OVERHAUL**

- Marine Engine Electrical System
- Cooling System (External)
- Transmissions

## **GENERATOR SETS**

## **HYDRAULIC CRANKING SYSTEM**

## **SERVICE BULLETINS**

IMPORTANT

PRODUCT SOFTWARE NOTICE

Product software of all kinds, such as brochures, drawings, technical data, operator's and workshop manuals, parts lists and parts price lists, and other information, instructions and specifications provided from sources other than Westerbeke, is not within Westerbeke's control and, accordingly, is provided to Westerbeke customers only as a courtesy and service. WESTERBEKE CANNOT BE RESPONSIBLE FOR THE CONTENT OF SUCH SOFTWARE, MAKES NO WARRANTIES OR REPRESENTATIONS WITH RESPECT THERETO, INCLUDING THE ACCURACY, TIMELINESS OR COMPLETENESS THEREOF, AND WILL IN NO EVENT BE LIABLE FOR ANY TYPE OF DAMAGES OR INJURY INCURRED IN CONNECTION WITH, OR ARISING OUT OF, THE FURNISHING OR USE OF SUCH SOFTWARE.

For example, components and sub-assemblies incorporated in Westerbeke's products and supplied by others (such as engine blocks, fuel systems and components, transmissions, electrical components, pumps and other products) are generally supported by their manufacturers with their own software, and Westerbeke must depend on such software for the design of Westerbeke's own product software. Such software may be outdated and no longer accurate. Routine changes made by Westerbeke's suppliers, of which Westerbeke rarely has notice in advance, are frequently not reflected in the supplier's software until after such changes take place.

Westerbeke customers should also keep in mind the time span between printings of Westerbeke product software, and the unavoidable existence of earlier, non-current Westerbeke software editions in the field. Additionally, most Westerbeke products include customer-requested special features that frequently do not include complete documentation.

In sum, product software provided with Westerbeke products, whether from Westerbeke or other suppliers, must not and cannot be relied upon exclusively as the definitive authority on the respective product. It not only makes good sense, but is imperative that appropriate representatives of Westerbeke or the supplier in question be consulted to determine the accuracy and currency of the product software being consulted by the customer.

## INTRODUCTION

### IMPORTANT

THIS MANUAL IS A DETAILED GUIDE TO THE INSTALLATION, START-UP, OPERATION AND MAINTENANCE OF YOUR WESTERBEKE MARINE DIESEL ENGINE. THE INFORMATION IT CONTAINS IS VITAL TO THE ENGINE'S DEPENDABLE, LONG TERM OPERATION.

READ IT !

KEEP IT IN A SAFE PLACE !

KEEP IT HANDY FOR REFERENCE AT ALL TIMES !

FAILURE TO DO SO WILL INVITE SERIOUS RISK, NOT ONLY TO YOUR INVESTMENT BUT YOUR SAFETY AS WELL.

### UNDERSTANDING THE DIESEL....

The diesel engine closely resembles the gasoline engine inasmuch as the mechanism is essentially the same. Its cylinders are arranged above its closed crankcase; its crankshaft is of the same general type as that of a gasoline engine; it has the same sort of valves, camshaft, pistons, connecting rods, lubricating system and reverse and reduction gear.

Therefore, it follows to a great extent that a diesel engine requires the same preventative maintenance as that which any intelligent operator would give to a gasoline engine. The most important factors are proper maintenance of the fuel, lubricating and cooling systems. Replacement of fuel and lubricating filter elements at the time periods specified is a must, and frequent checking for contamination (i.e. water, sediment, etc.) in the fuel system is also essential. Another important factor is the use of the same brand of "high detergent" diesel lubricating oil designed specifically for diesel engines.

The diesel engine does differ from the gasoline engine, however, in the method of handling and firing its fuel. The carburetor and ignition systems are done away with and in their place is a single component - the Fuel Injection Pump - which performs the function of both.

Unremitting care and attention at the factory have resulted in a Westerbeke engine capable of many thousands of hours of dependable service. What the manufacturer cannot control, however, is the treatment it receives in service. This part rests with you!

### ORDERING PARTS

Whenever replacement parts are needed, always include the complete part description and part number (see separate Parts List furnished, if not part of this publication). Be sure to include the engine's model and serial number. Also, be sure to insist upon Westerbeke factory packaged parts, because "will fit" parts are frequently not made to the same specifications as original equipment.

### GENERATOR SETS

Westerbeke diesels are used for both the propulsion of boats and for generating electrical power. For generator set applications, all details of this Manual apply, except in regard to certain portions of the Installation, Operation and Maintenance sections. Additional information is provided in the section titled Generator Sets, Section T.

## YOUR NOTES

[www.torresen.com](http://www.torresen.com)

# INSTALLATION

## FOREWORD

Since the boats in which these engines are used are many and varied, details of engine installation are equally so. It is not the purpose of this section to advise boatyards and engine installers on the generally well understood and well developed procedures for installation of engines. However, the following outline of general procedure is included because it is valuable in explaining the functions of each component, the reasons why, the precautions to be watched and the relationship of the installation to the operation of the engine. There are details of the installation which should have a periodic check and of which the operator should have a thorough understanding to insure good operating conditions for the engine and correct procedure for its servicing.

## INSPECTION OF EQUIPMENT

The engine is shipped from the factory mounted securely and properly crated. Accessory equipment is shipped in a separate small box, usually packed with the engine crate.

Before accepting shipment from the transportation company, the crate should be opened and an inspection made for concealed damage. If either visible or concealed damage is noted, you should require the delivering agent to sign "Received in damaged condition". Also check contents of the shipment against the packing list and make sure note is made of any discrepancies. This is your protection against loss or damage. Claims for loss or damage must be made to the carrier, not to J. H. Westerbeke Corporation.

## RIGGING AND LIFTING

The engine is fitted with lifting rings.

Rope or chain slings should be attached to the rings and the engine lifted by means of tackle attached to this sling. The lifting rings have been designed to carry the full weight of the engine; therefore, auxiliary slings are not required or desired.

**CAUTION:** Slings must not be so short as to place the engine lifting eyes in significant sheer stress. Strain on the engine lifting eyes must not be in excess of 10° from the vertical. A spacer bar must be placed between the two lifting eyes, if supported by valve cover studs.

The general rule in moving engines is to see that all equipment used is amply strong and firmly fixed in place. Move the engine a little at a time and see that it is firmly supported. Eliminate possibility of accidents by avoiding haste. Do not lift from the propeller coupling, or pry against this with crowbar, as you may distort the coupling.

In some cases it may be necessary to lift the engine in other than the regular horizontal position. It may be that the engine must be lowered endwise through a small hatchway which cannot be made larger. If the opening is extremely restricted, it is possible to reduce, to some extent, the outside clearances such as generator, cooling piping, water tank, filters, mounting lugs, etc. This accessory equipment should be removed by a competent mechanic and special care should be



taken to avoid damage to any exposed parts and to avoid dirt entering openings. The parts which have been removed should be returned to position as soon as the restriction has been passed.

In case it is necessary to hoist the engine either front end upwards or reverse gear end upwards, the attachment of slings must be done very carefully to avoid the possibility of damage to the parts on which the weight may bear. It is best if special rigging work be done by someone experienced and competent in the handling of heavy machinery.

#### ENGINE BOLTS

It is recommended that bronze hanger bolts of appropriate size be used through the engine flexible mounts. Lag screws are less preferred because their hold on the wood is weakened every time they are moved, whereas the lag bolt stays in position and the nut on top is used to tighten the engine down or is removed to permit the engine to be lifted. The bolt itself stays in position at all times, as a stud, and the bond between the bolt and the wood is not weakened by its removal.

#### FOUNDATION FOR ENGINE

A good engine bed contributes much toward the satisfactory operation of the engine. The engine bed must be of rigid construction and neither deflect nor twist when subjected to the engine weight or the position the boat may have to take under the effects of rough seas. The bed must keep the engine within one or two thousandths of an inch of this position at all times. It has to withstand the forward push of the propeller which is applied to the propeller shaft, to the thrust washer bearing in the engine and finally to the engine bolts and engine bed.

In fiberglass hulls, we recommend that similar wooden stringers as in wooden hulls be formed and fitted, then glassed to the hull securely. This allows hanger bolts to be installed firmly in wood, thus reducing noise and transmitted vibration.

The temptation to install the engine on a pair of fiberglass "angle irons" should be resisted. Such construction will allow engine vibrations to pass through to the hull. Flexible mounts require a firm foundation against which to react if they are to do their job. When possible, follow bed design "A" and avoid bed design "B".

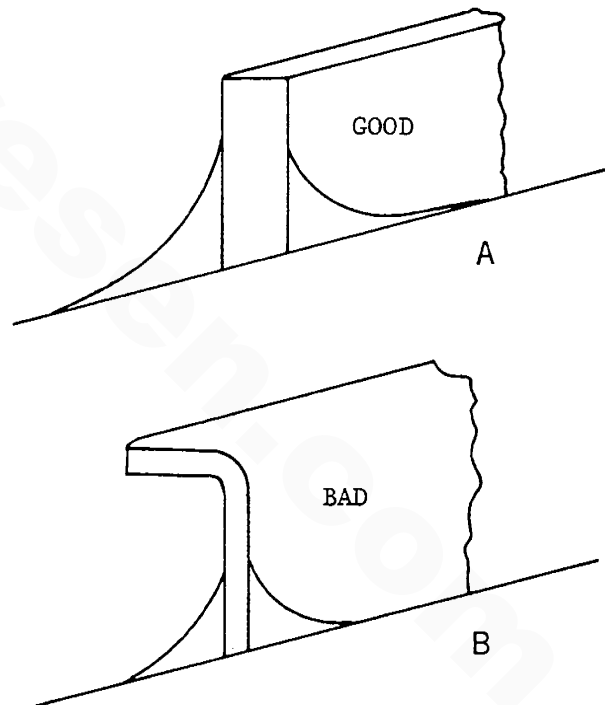

#### PROPELLER COUPLING

Each Westerbeke Diesel engine is regularly fitted with a suitable coupling connecting the propeller shaft to the engine.

The coupling must not only transmit the power of the engine to turn the shaft, but must also transmit the thrust either ahead or astern from the shaft to the thrust bearing which is built into the reduction gear housing of the engine. This coupling is very carefully machined for accurate fit.

For all engine models, a propeller half-coupling, bored to shaft size for the specific order, is supplied. The coupling either has a keyway with set screws or is of the clamping type.

The forward end of the propeller shaft has a long straight keyway. Any burrs should be removed from the shaft end. The coupling should be a light drive fit on the shaft and the shaft should not have to be scraped down or filed in order to get a fit. It is important that the key be properly fitted both to the shaft and the coupling. The key should fit the side of the keyway very closely, but should not touch the top of the keyway in the hub of the coupling.

If it seems difficult to drive the coupling over the shaft, the coupling can be expanded by heating in a pail of boiling water. The face of the propeller coupling must be exactly perpendicular to the centerline or axis of the propeller shaft.

#### PROPELLER

The type and size of propeller varies with the gear ratio and must be selected to fit the application based upon boat tests. To utilize the full power of the engine, and to achieve ideal loading conditions, it is desirable to use a propeller which will permit the engine to reach its full rated speed at full throttle under normal load.

#### ALIGNMENT OF ENGINE

The engine must be properly and exactly aligned with the propeller shaft. No matter what material is used to build a boat it will be found to be flexible to some extent and the boat hull will change its shape to a greater extent than is usually realized when it is launched and operated in the water. It is therefore very important to check the engine alignment at frequent intervals and to correct any errors when they may appear.

Misalignment between the engine and the propeller shaft is the cause of troubles which are blamed often on other causes. It will create excessive bearing wear, rapid shaft wear and will, in many cases, reduce the life of the hull by loosening the hull fastenings. A bent propeller shaft will have exactly the same effect and it is therefore necessary that the propeller shaft itself be perfectly straight.

One particularly annoying result of misalignment may be leakage of transmission oil through the rear oil seal. Check to make sure that alignment is within the limits prescribed.

The engine should be moved around on the bed and supported on the screw-jacks or shims until the two halves of the couplings can be brought together without using force and so that the flanges meet evenly all around. It is best not to drill the foundation for the foundation bolts until the approximate alignment has been accurately determined.

Never attempt a final alignment with the boat on land. The boat should be in the water and have had an opportunity to assume its final water form. It is best to do the alignment with the fuel and water tanks about half full and all the usual equipment on board and after the main mast has been stepped and final rigging has been

accomplished.

Take plenty of time in making this alignment and do not be satisfied with anything less than perfect results.

The alignment is correct when the shaft can be slipped backward and forward into the counterbore very easily and when a feeler gauge indicates that the flanges come exactly together at all points. The two halves of the propeller coupling should be parallel within 0.002 inches (A).

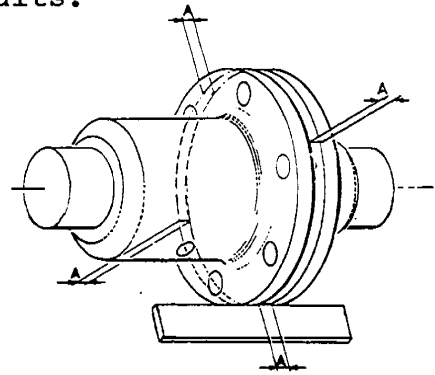

In making the final check for alignment, the engine half coupling should be held in one position and the alignment with the propeller coupling tested with the propeller coupling in each of four positions, rotated 90° between each position. This test will also check whether the propeller half coupling is in exact alignment on its shaft. Then, keeping the propeller coupling in one position, the alignment should be checked rotating the engine half coupling to full position each 90° from the next one.

The engine alignment should be rechecked after the boat has been in service for one to three weeks and, if necessary, the alignment remade. It will usually be found that the engine is no longer in alignment. This is not because the work was improperly done at first but because the boat has taken some time to take its final shape, and the engine bed and engine stringers have probably absorbed some moisture. It may even be necessary to re-align at a further period.

The coupling should always be opened up and the bolts removed whenever the boat is hauled out or moved from the land to the water, and during storage in a cradle. The flexibility of the boat often puts a very severe strain on the shaft or the coupling or both when it is being moved. In some cases the shaft has actually been bent by these strains. This does not apply to small boats that are hauled out of the water when not in use, unless they are dry for a considerable time.

#### EXHAUST SYSTEM

Exhaust line installations vary considerably and each must be designed for the particular job. The general requirements are to provide an outlet line with a minimum of restrictions and arranged so that sea water, rain water or condensation cannot get back into the engine. There should be a considerable fall in the line between the exhaust manifold flange and the discharge end. This slope in the pipe makes it difficult for water to be driven in very far by a wave, and a steep drop followed by a long slope is better than a straight gradual slope. Avoid any depression or trough to the line which would fill with water and obstruct the flow of exhaust gas. Also avoid any sharp bends.

Brass or copper is not acceptable for wet exhaust systems, as the combination of salt water and diesel exhaust gas will cause rapid deterioration. Galvanized iron fittings and galvanized iron pipe are recommended for the exhaust line. The exhaust line must be at least as large as the engine exhaust manifold flange and be increased in size if there is an especially long run and/or many elbows. It should be increased by 1/2" in I.D. for every 10 feet beyond the first

10 feet.

Most exhaust systems today use a water lift type muffler such as the Westerbeke "Hydro-Hush". In most installations there is a dry, insulated high loop after the engine manifold and before the muffler to prevent water flowing backwards into the engine during cranking.

It is essential not to hang too much weight in the form of exhaust system components rigidly from the engine manifold. Generally, it is permissible to directly connect a pipe nipple and a water jacketed exhaust elbow, which two components weigh about 8 pounds (4 kg). If there are more components to be rigidly connected to each other than will weigh 8 pounds, then a flexible exhaust section must be installed between the manifold outlet and the exhaust system.

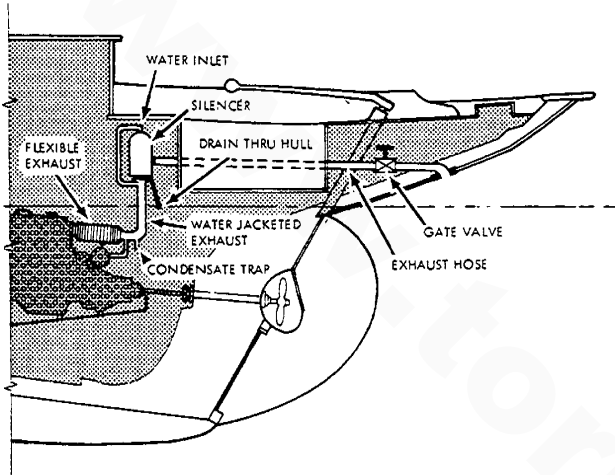

EXHAUST SYSTEM WITH WATER JACKETED STANDPIPE

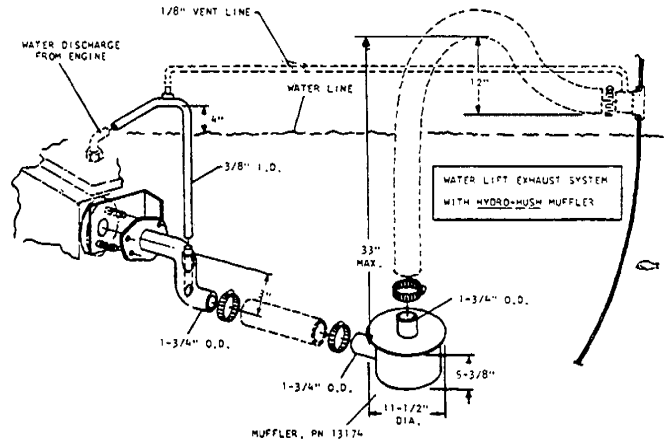

WATER LIFT EXHAUST SYSTEM WITH "HYDRO-HUSH MUFFLER"

The exhaust system must be supported or suspended independently of the engine manifold, usually using simple metal hangers secured to the overhead.

All dry portions of the exhaust system should be wrapped in suitable insulation material to keep surface temperatures as low as possible.

Many installations use flexible rubber exhaust hose for the water cooled section of the exhaust line because of the ease of installation and flexibility. Provide adequate support for the rubber hose to prevent sagging, bending and formation of water pockets.

Always arrange the rubber hose section so that water cannot possibly flow back into the engine. Also make sure that entering sea water cannot spray directly against the inside of the exhaust piping. Otherwise, excessive erosion will occur.

**MEASURING EXHAUST GAS BACK PRESSURE**

Back pressure must be measured on a straight section of the exhaust line and as near as possible to the engine exhaust manifold. The engine should be run at maximum load during the measurement period. Set-up should be as shown below.

1. For normally aspirated engines:

<u>Pressure Test</u>	<u>Mercury Test</u>	<u>Water Column</u>
1-1/2" Max PSI	3" Mercury	= 39"

2. For turbo-charged engines:

<u>Pressure Test</u>	<u>Mercury Test</u>	<u>Water Column</u>
0.75 Max PSI	1-1/2" Mercury	= 19-1/2"

### Checking The Back Pressure

1. Exhaust pipe flange
  2. Exhaust line
  3. Transparent plastic hose, partly filled with water.
- Measurement "A" may not exceed 39" for normally aspirated engines and 19.5" for turbo-charged engines.

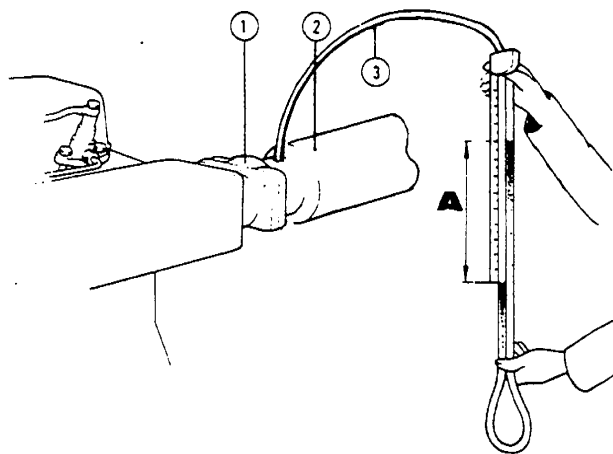

### WATER CONNECTIONS

Seacocks and strainers should be of the full flow type at least one size greater than the inlet thread of the sea water pump. The strainer should be of the type which may be withdrawn for cleaning while the vessel is at sea.

Water lines can be copper tubing or wire-wound, reinforced rubber hose. In any case, use a section of flexible hose that will not collapse under suction, between the hull inlet and engine and between the outlet and the exhaust system. This takes up vibration and permits the engine to be moved slightly when it is being re-aligned. Do not use street elbows in suction piping. All pipe and fittings should be of bronze. Use sealing compound at all connections to prevent air leaks. The neoprene impeller in the sea (raw) water pump should never be run dry.

### FUEL TANK AND FILTERS

Fuel tanks may be of fiberglas, monel, aluminum, plain steel or terne plate. If made of fiberglas, be certain that the interior is gel coated to prevent fibers from contaminating the fuel system. Copper or galvanized fuel tanks should not be used. It is not necessary to mount the tank above the engine level as the fuel lift pump provided will raise the fuel from the tank. The amount of lift should be kept minimum (6 feet being maximum). If a tank is already installed above the engine level, it can be utilized in this position. Great care should be taken to ensure that the fuel system is correctly installed so that airlocks are eliminated and precautions taken against dirt and water entering the fuel.

A primary fuel filter of the water collecting type should be installed between the fuel tank and the fuel lift pump. A recommended type is available from the list of accessories. The secondary fuel filter is fitted on the engine between the fuel lift pump and the injection pump and has a replaceable element.

As the fuel lift pump has a capacity in excess of that required by the injection pump, the overflow is piped to the fuel tank and should be connected to the top of the tank or as near the top as possible.

To insure satisfactory operation, a diesel engine must have a dependable supply of clean diesel fuel. For this reason, cleanliness and care are especially important at the time when the fuel tank is installed, because dirt left anywhere in the fuel lines or tank will certainly cause fouling of the injector nozzles when the engine is started for the first time.

### FUEL PIPING

We recommend copper tubing together with suitable fittings, both

for the supply line and the return line. Run the tubing in the longest pieces obtainable to avoid the use of unnecessary fittings and connectors. The shut off valve in the line between the fuel tank and engine should be of the fuel oil type, and it is important that all joints be free of pressure leaks.

Keep fuel lines as far as possible from exhaust pipe for minimum temperature, to eliminate "vapor locks".

The fuel piping leading from the tank to the engine compartment should always be securely anchored to prevent chafing. Usually the copper tubing is secured by means of copper straps.

The final connection to the engine should be through flexible rubber hoses.

#### ELECTRIC PANEL

The Westerbeke all-electric panel utilizes an electronic tachometer with a built-in hourmeter. Tachometer cables are no longer required, except for the Skipper mechanical panel. Mounted on the panel are a voltmeter, water temperature gauge and oil pressure gauge. Each instrument is lighted. The all-electric panel is isolated from ground and may be mounted where visible. It is normally pre-wired.

#### ELECTRICAL EQUIPMENT

Most Westebeke engines are supplied pre-wired and with plug-in connectors. Never make or break connections while the engine is running. Carefully follow all instructions on the wiring diagram supplied, especially those relating to fuse/circuit breaker requirements.

Starter batteries should be located as close to the engine as possible to avoid voltage drop through long leads. It is bad practice to use the starter batteries for other services unless they require low amperage or are intermittent. In cases where there are substantial loads (from lights, refrigerators, radios, depth sounders, etc.), it is essential to have a complete, separate system and to provide charging current for this by means of a second alternator or "alternator output splitter".

Starter batteries must be of a type which permits a high rate of discharge (Diesel starting).

Carefully follow the recommended wire sizes shown in the wiring diagrams. Plan installation so the battery is close to the engine and use the following cable sizes:

- #1 - for distances up to 8 feet
- #1/0 - for distances up to 10 feet
- #2/0 - for distances up to 13 feet
- #3/0 - for distances up to 16 feet

#### MECHANICAL CONTROLS

The recommended practice is to have the stop-run lever loaded to the run position and controlled by a sheathed cable to a push-pull knob at the pilot station. The throttle lever should be connected to a Morse type lever at the pilot station by a sheathed cable.

The transmission control lever may be connected to the pilot station by a flexible, sheathed cable and controlled by a Morse type lever. The single-lever type gives clutch and throttle control with full throttle range in neutral position. The two-lever type provides clutch control with one lever and throttle control with the other.

Any bends in the control cables should be gradual. End sections

at engine and transmission must be securely mounted. After linkages are completed, check the installation for full travel, making sure that, when the transmission control lever at the pilot station is in forward, neutral and reverse, the control lever on the transmission is on the respective detent. Check the throttle control lever and the stop-run lever on the fuel injection pump for full travel.

Some models do not require a stop cable because they have either a fuel solenoid or an electric fuel pump. Examples of such models are the W58 and the W52.

[www.torresen.com](http://www.torresen.com)

## OPERATION

### PREPARATION FOR FIRST START

The engine is shipped "dry"...with lubricating oil drained from the crankcase and fluid from the transmission. Therefore, be sure to follow these recommended procedures carefully before starting the engine for the first time.

1. Remove oil filler cap and fill oil sump with heavy duty, diesel lubricating oil to the highest mark on the dipstick. See table under Maintenance for an approved lubricating oil. Do not overfill. Select an approved grade from the listing and continue to use it.

2. Fill the reverse gear to the highest mark on the dipstick with TYPE A transmission fluid. Do not overfill. Refer to the Transmission Section of this manual for details.

Engine oil is not recommended because it can foam, and it can contain additives harmful to some transmissions.

If the engine is equipped with a V-drive, fill to the full mark on the dipstick with the recommended lubricant specified on the data tag on the V-drive housing.

3. Fill fresh water cooling system with a 50-50 antifreeze solution only after opening all petcocks and plugs until all entrapped air is expelled.

Fill surge tank to within one inch of the top. Check this level after engine has run for a few minutes. If trapped air is released, the water level may have dropped. If so, refill tank to within one inch of top and replace filler cap.

4. Ensure battery water level is at least 3/8" above the battery plates and battery is fully charged so that it is capable of the extra effort that may be required on the first start.

5. Fill fuel tank with clean diesel fuel oil; No. 2 diesel fuel oil is recommended. The use of No. 1 is permissible but No. 2 is preferred because of its higher lubricant content.

NOTE: If there is no filter in the filler of the fuel tank, the recommended procedure is to pour the fuel through a funnel of 200 mesh wire screen.

6. Fill grease cup on the sea water pump, if present, with a good grade of water pump grease.

### FUEL SYSTEM

The fuel injection system of a compression ignition engine depends upon very high fuel pressure during the injection stroke to function correctly. Relatively tiny movements of the pumping plungers produce this pressure and, if any air is present inside the high pressure line, then this air acts as a cushion and prevents the correct pressure, and therefore fuel injection, from being achieved.

In consequence, it is essential that all air is bled from the system whenever any part of the system has been opened for repair or servicing.



BLEEDING PROCEDURES BY MODEL

1. Initial Engine Start-up (Engine stoppage due to lack of fuel)
  - a. Insure that the fuel tank(s) is filled with the proper grade of diesel fuel.
  - b. Fill any large primary filter/water separator with clean diesel fuel that is installed between the fuel tank and engine. To attempt to fill any large primary filter using the manual priming lever on the engine mounted fuel lift pump may prove futile or require a considerable amount of priming.
  - c. Turn the fuel selector valve to "On". Systems with more than one tank insure that fuel returning is going to the tanks being used.

The above procedures are basic for all initial engine start-ups or for restarting engines stopping due to lack of fuel.

WESTERBEKE W7 AND WPD4 GENERATOR (3600 RPM) (Figure 1)

1. With the use of a 5/16 box wrench or common screw driver, open the bleed screw one or two turns on the outgoing side of the engine mounted secondary fuel filter (Bleed point A). With firm strokes on the lift pump priming lever, bleed until fuel free of air bubbles flows from this point. Stop priming and gently tighten the bleed screw.
2. With a 5/8 open end wrench loosen one to two turns the nut securing the injector line to the injector (Bleed point B).

Decompress the engine with the lever on the top of the cylinder head. Crank the engine over with the starter. (W7: ensure that the engine stop lever is in the run position and the throttle is full open.) (4KW: use the defeat position while cranking.) Crank the engine until fuel spurts by the nut and line. Stop cranking and tighten the 5/8 nut and proceed with normal starting procedures.

WESTERBEKE W30 (Figure 2), W40 & WPO10, 12 $\frac{1}{2}$ , 15 (Figure 3), W50 & WBO 15 (Figure 4), W80 & BR 30 (Figure 5), W120 & BR 45 (Figure 5)

1. Open the banjo bolt on top of the engine mounted secondary fuel filter 1-2 turns (Bleed Point A). With firm stroke on the fuel lift pump priming lever, bleed until fuel free of air bubbles flows from this point. Stop priming and tighten the bolt.
2. On the fuel injection pump body is a 5/16 bleed screw (Bleed Point B). This may be mounted on a manifold with a pressure switch. Open this one or two turns (do not remove it) and with the priming lever bleed until fuel free of air bubbles flows. Stop priming and tighten the bleed screw.
3. On the control cover of the injection pump (Bleed Point C) is a 5/16 bleed screw. Open this screw one to two turns and proceed as in Step 2. (Note: Bypass this bleed point on the W30 injection pump.)

4. W50 injection pump only. Open the 5/16 bleed screw (Bleed Point D) on the injector line banjo bolt one or two turns and, with the throttle full open and the engine stop lever in the run position, crank the engine over with the starter until clear fuel free of air flows from this point. Stop cranking and tighten this bleed screw.
5. With a 5/8 wrench loosen one to two turns the injector line attaching nuts at the base of each injector and, with the throttle full open and the engine stop control in the run position, crank the engine over with the starter until fuel spurts by the nuts and injector line at each injector. Stop cranking and tighten the nut and proceed with normal starting procedures.

WESTERBEKE W13, 4.4KW, W21, 7.7KW, W27, 11.1KW, W33, 12.5KW (Figure 6)

These units are self-bleeding.

1. Turn the ignition to the ON position and wait 15-20 seconds.
2. Start the engine following normal starting procedures.

WESTERBEKE W58 & WTO 20 (Figure 7)

1. Open the bleed screw on the top inboard side of the engine-mounted secondary fuel filter one to two turns using a 10mm box wrench (Bleed Point A). This fuel filter is equipped with a hand-operated priming pump. With the palm of your hand, pump this primer until fuel free of air flows from this point. Stop pumping and tighten the bleed screw.
2. With bleed screw A tightened, pump the hand primer several more times. This primes the injection pump which is self-bleeding. The injection pump incorporates a feed pump which keeps the fuel system primed when the engine is running; thus, no external lift pump is required.
3. Loosen the four injector line attaching nuts at the base of each injector (Bleed Point B) one to two turns with a 16mm open end wrench. Place the throttle in the full open position and crank the engine over with the the starter until fuel spurts by the nut and injector lines. Stop cranking and tighten each of the four nuts and proceed with normal starting procedure.

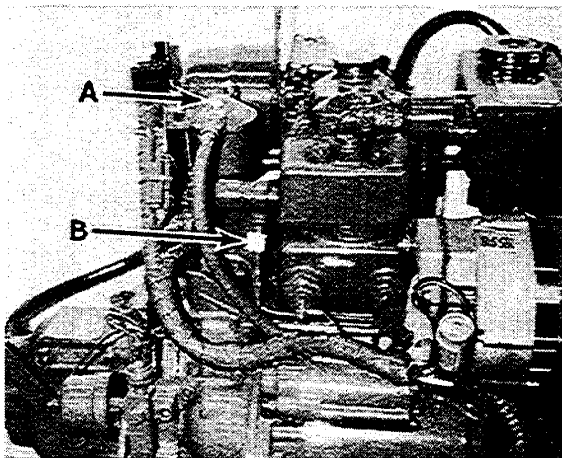

Figure 1

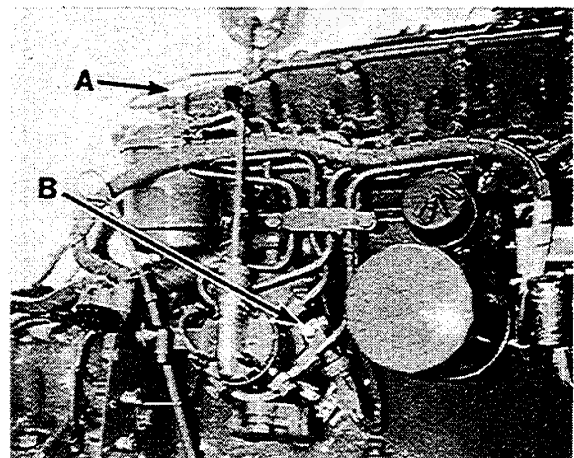

Figure 2

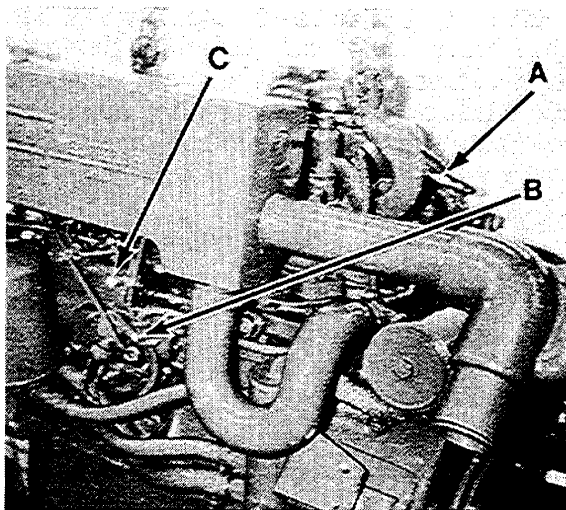

Figure 3

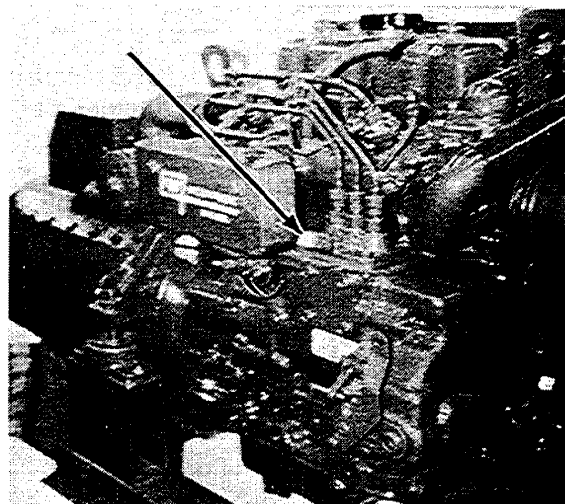

Figure 6

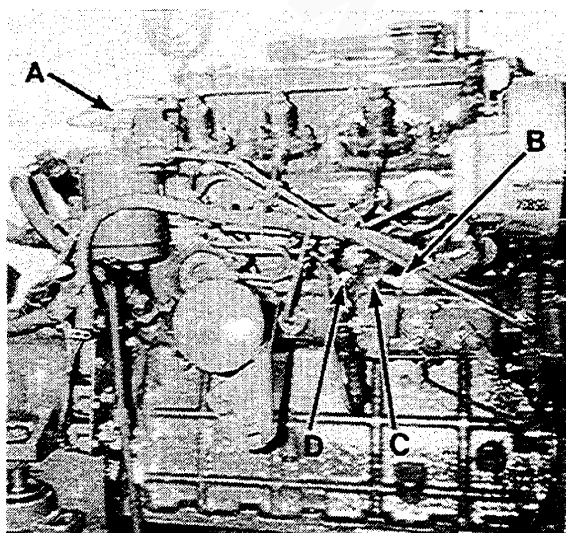

Figure 4

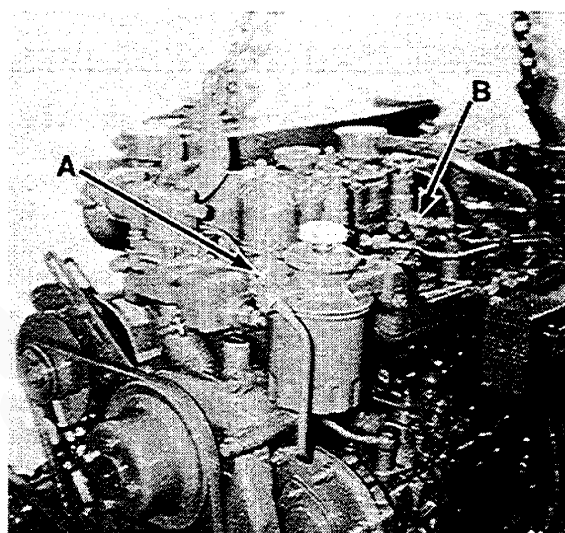

Figure 7

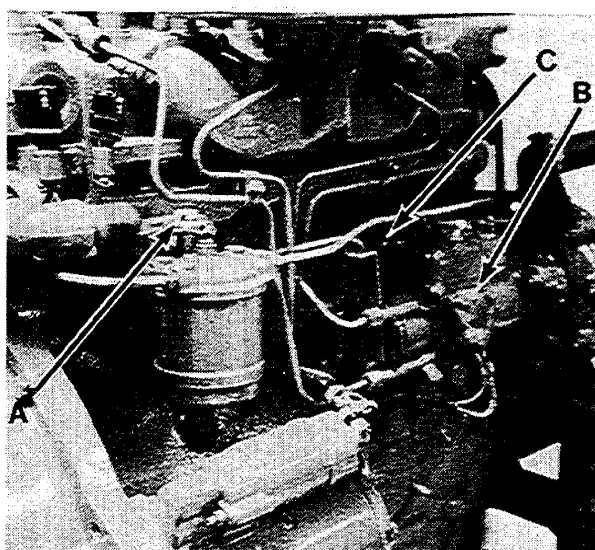
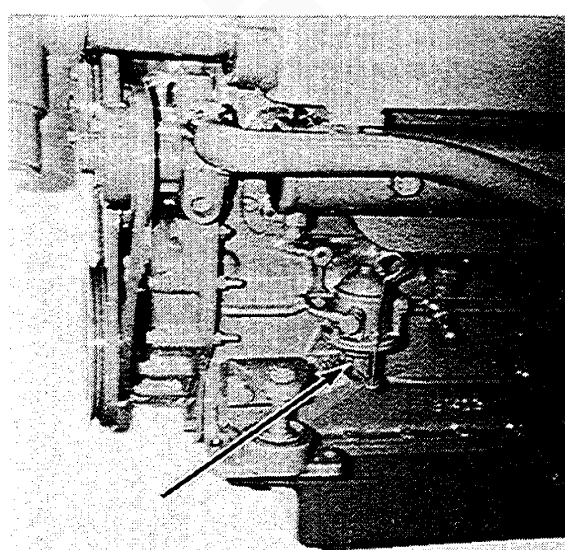

Figure 5



Typical Mechanical Fuel  
Lift Pump

### PREPARATION FOR STARTING

1. Check water level in expansion tank. It should be 1½ to 2 in. below the top of the tank when cold.
2. Check the engine sump oil level.
3. Check the transmission fluid level.
4. See that there is fuel in the tank and the fuel shut-off is open.
5. Check to see that the starting battery is fully charged, all electrical connections are properly made, all circuits in order and turn on the power at the battery disconnect.
6. Check the seacock and ensure that it is open.

### STARTING THE ENGINE (COLD)

Most Westerbeke marine diesel engines are equipped with a cold starting aid to ease in the starting of your engine when cold.

1. Check to see that the "stop" lever (if installed) is in the "run" position.
2. Place the throttle in the fully open position.
3. Press the "Preheat" button in and hold for 15 to 20 seconds.
4. While holding the "Preheat" button in, turn the keyswitch to the "ON" or "Run" position. This activates the panel gauges, lights and fuel solenoid or electric fuel pump if so equipped. Continue to turn the keyswitch to the "Start" position and hold for no more than 20 seconds. Some units may be equipped with a pushbutton to start rather than the keyswitch and in these cases the electrical system is activated by fuel pressure.
5. If the engine fails to start in 20 seconds, release start switch and preheat for an additional 15 to 20 seconds, then repeat step 4.
6. As soon as the engine starts, release the start switch and the preheat button and return the throttle to the "idle" position immediately.

**CAUTION:** Do not crank the engine more than 20 seconds when trying to start. Allow a rest period of at least twice the cranking period between the start cycles. Starter damage may occur by overworking the starter motor and the backfilling of the exhaust system is possible.

### STARTING THE ENGINE (WARM)

If the engine is warm and has only been stopped for a short time, place the throttle in the partially open position and engage the starter as above, eliminating the preheat step.

NOTE: Always be sure that the starter pinion has stopped revolving before again re-engaging the starter; otherwise, the flywheel ring gear or starter pinion may be damaged.

Ensure that the electrical connection to the cold starting aid is correct.

Extended use of the cold starting aid beyond the time periods stated should be avoided to prevent damage to the aid.

NEVER under any circumstances use or allow anyone to use ether to start your engine. If your engine will not start, then have a qualified Westerbeke marine mechanic check your engine.

#### WHEN ENGINE STARTS

1. Check for normal oil pressure immediately upon engine starting. Do not continue to run engine if oil pressure is not present within 15 seconds of starting the engine.
2. Check Sea Water Flow. Look for water at exhaust outlet. Do this without delay.
3. Recheck Crankcase Oil. After the engine has run 3 or 4 minutes, subsequent to an oil change or new installation, stop the engine and check the crankcase oil level. This is important as it may be necessary to add oil to compensate for the oil that is required to fill the engine's internal oil passages and oil filter. Add oil as necessary. Check oil level each day of operation.
4. Recheck Transmission Fluid level. (This applies only subsequent to a fluid change or new installation.) In such a case, stop the engine after running for several minutes at 800 RPM with one shift into forward and one into reverse, then add fluid as necessary. Check fluid level each day of operation.
5. Recheck Expansion Tank Water Level, if engine is fresh water cooled. (This applies after cooling system has been drained or filled for the first time.) Stop engine after it has reached operating temperature of 175°F and add water to within one inch of top of tank.

WARNING: The system is pressurized when overheated, and the pressure must be released gradually if the filler cap is to be removed. It is advisable to protect the hands against escaping steam and turn the cap slowly counter-clockwise until the resistance of the safety stops is felt. Leave the cap in this position until all pressure is released. Press the cap downward against the spring to clear the safety stops and continue turning until it can be lifted off.

6. Warm-up Instructions. As soon as possible, get the boat underway, but at reduced speed, until water temperature gauge indicates 130-150°F. If necessary, engine can be warmed up with the transmission in neutral at 1000 RPM. Warming up with the transmission in neutral takes longer and tends to overheat the transmission.

7. Reverse Operation. Always reduce engine to idle speed when shifting gears. However, when the transmission is engaged, it will carry full engine load.

NOTE: The SA0 transmission requires that when backing down, the shift lever must be held in the reverse position, since it has no positive overcenter locking mechanism.

#### STOPPING THE ENGINE

1. Position shift lever in neutral.
2. Idle the engine for 2 to 4 minutes to avoid boiling and to dissipate some of the heat.
3. If equipped with a stop lever, pull the knob and hold in this position until the engine stops. This stops the flow of fuel at the injection pump. After the engine stops, return the control to the run position to avoid difficulty when restarting the engine.
4. Turn off the keyswitch. Some models do not use the stop lever as they are equipped with a fuel solenoid or electric fuel pump which shuts off the fuel supply when the keyswitch is turned to the OFF position.
5. Close the seacock.
6. Disconnect power to system with battery switch.

#### OPERATING PRECAUTIONS

1. Never run engine for extended periods when excessive overheating occurs, as extensive internal damage can be caused.
2. DO NOT put cold water in an overheated engine. It can crack the cylinder head, block or manifold.
3. Keep intake silencer free from lint, etc.
4. Do not run engine at high RPM without clutch engaged.
5. Never Race a Cold Engine as internal damage can occur due to inadequate oil circulation.
6. Keep the engine and accessories clean.
7. Keep the fuel clean. Handle it with extreme care because water and dirt in fuel cause more trouble, and service life of the injection system is reduced.
8. Do not allow fuel to run low, because fuel intake may be uncovered long enough to allow air to enter the injection system, resulting in engine stoppage requiring system bleeding.

9. Do not be alarmed if temperature gauges show a high reading following a sudden stop after engine has been operating at full load. This is caused by the release of residual heat from the heavy metal masses near the combustion chamber. Prevention for this is to run engine at idle for a short period before stopping it. High temperature reading after a stop does not necessarily signal alarm against restarting. If there is no functional difficulty, temperatures will quickly return to normal when engine is operating.

[www.torresen.com](http://www.torresen.com)

## TEN MUST RULES

IMPORTANT

IMPORTANT

IMPORTANT

...for your safety and your engine's dependability.

### ALWAYS -

1. Keep this Manual handy and read it whenever in doubt.
2. Use only filtered fuel oil and check lube oil level daily.
3. Check cooling water temperature frequently to make sure it is 190° or less.
4. Close all drain cocks and refill with water before starting out.
5. Investigate any oil leaks immediately.

### NEVER -

6. Race the engine in neutral.
7. Run the engine unless the gauge shows proper oil pressure.
8. Break the fuel pump seals.
9. Use cotton waste or fluffy cloth for cleaning or store fuel in a galvanized container.
10. Subject the engine to prolonged overloading or continue to run it if black smoke comes from the exhaust.



## MAINTENANCE

### PERIODIC ATTENTION:

After you have taken delivery of your engine, it is important that you make the following checks right after the first fifty hours of its operation.

Note: Transmissions generally require fluid change after the first 25 to 30 hours of operation. Refer to the Transmission Section of this manual for details.

### FIFTY HOUR CHECKOUT (INITIAL)

Do the following:

1. Retorque the cylinder head bolts.
2. Retorque the rocker bracket nuts and adjust valve rocker clearance.
3. Check and adjust, if necessary, the forward drum assembly and the reverse band on manual SA0 and SA-1 transmissions.
4. Change engine lubricating oil and oil filter.
5. Check for fuel and lubricating oil leaks. Correct if necessary.
6. Check cooling system for leaks and inspect water level.
7. Check for loose fittings, clamps, connections, nuts, bolts, vee belt tensions, etc. Pay particular attention to loose engine mounts engine mount fittings. These could cause misalignment.

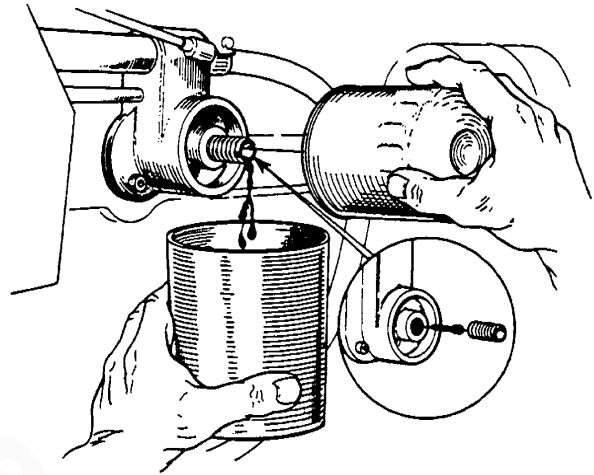

### DAILY CHECKOUT

Do the following:

1. Check the sea water strainer, if one has been installed.
2. Check water level in cooling system.
3. Check lubricating oil level in sump. Fill to highest mark on dipstick.
4. Turn down grease cup on water pump, if used, one full turn.
5. Check fluid level in transmission. Fill to highest mark on dipstick with proper fluid.

### SEASONAL CHECK-OUT (MORE OFTEN IF POSSIBLE)

Do the following:

1. Check generator, alternator and sea water pump "V" belts for proper tension.
2. Check water level in battery.
3. Change oil in sump. See Note.
4. Replace lubricating oil filter, Figure 2. See Note.
5. Fill sump with diesel lubricating oil to highest mark on dipstick. Refer to Specification page for proper quantity of oil. Do Not Overfill. See Note.

**CAUTION:** The use of different brands of lubricating oils during oil changes has been known to cause extensive oil sludging and may in many instances cause complete oil starvation.

6. Start engine and run for 3 or 4 minutes. Stop engine and check oil filter gasket for leaks. Check oil sump level. This is important as it may be necessary to add oil to compensate for the oil that is required to fill the engine's internal oil passages and oil filter. Add oil as necessary. See Note.

#### IMPORTANT NOTE

IT IS MANDATORY THAT THE CHECKS 3, 4, 5 AND 6 BE ATTENDED TO WHEN TOTAL OPERATING TIME REACHES 150 HOURS. IN SOME INSTANCES, THIS TOTAL IS REACHED BEFORE END OF SEASON.

7. Clean Air Filter if supplied. (Most models have an air silencer that does not require cleaning.) The time period for replacing the air filter depends on operating conditions; therefore, under extremely dirty conditions, the seasonal frequency should be increased. The correct time periods for replacing the filter will greatly assist in reducing bore wear, thereby extending the life of the engine.

8. Check engine for loose bolts, nuts, etc.

9. Check sea water pump for leaks.

10. Wash primary filter bowl and screen. If filter bowl contains water or sediment, filter bowl and secondary oil fuel filter need be cleaned more frequently.

11. Replace secondary fuel filter element.

12. Replace air filter.

13. Change the fluid in the transmission. Refer to the Transmission Section of this manual for details.

#### END OF SEASON SERVICE

1. Drain fresh water cooling system by removing the surge tank pressure cap and opening all water system petcocks.

2. Remove zinc rod (usually located in heat exchanger) and see if it needs replacing. The zinc rod will take care of any electrolysis that may occur between dissimilar metals. Insert new zinc if necessary.

3. Fill fresh water cooling system with antifreeze of a reputable make. (Refer to Cold Weather Precautions.)

4. Start engine. When temperature gauge indicates 175°F, shut engine down and drain lubricating oil. Remove and replace filter. Fill sump with High Detergent Lubricating Oil.

5. Carefully seal air intake opening with waterproofed adhesive tape or some other suitable medium.

6. Seal the exhaust outlet at the most accessible location as close to the engine as possible.

7. Remove injectors and spray oil into cylinders.

8. Replace injectors with new sealing washer under each injector. Turn engine slowly over compression.

9. Top off fuel tank completely so that no air space remains, thereby preventing water formation by condensation.

10. Leave fuel system full of fuel.

11. Change fuel filters before putting the engine back in service.

12. Wipe engine with a coat of oil or grease.

13. Change fluid in transmission. Refer to the Transmission Section of this manual for details.

14. Disconnect battery and store in fully charged condition. Before

storing the battery, the battery terminals and cable connectors should be treated to prevent corrosion. Recharge battery every 30 days.  
15. Check alignment.

[www.torresen.com](http://www.torresen.com)

LUBRICATING OILS

Lubricating oils are available for Westerbeke Diesel engines which offer an improved standard of performance to meet the requirements of modern operating conditions such as sustained high speeds and temperatures.

These oils meet the requirements of the U. S. Ordnance Specifications MIL-L-2104B (API Service CC). Any other oils which also conform to these specifications, but are not listed here, are, of course, also suitable.

COMPANY	BRAND	S.A.E. DESIGNATION		
		0°/45°F	45°/80°F	OVER 80°F
American Oil Co.	American Supermil Motor Oil	10W	20W/20	30
BP Canada Ltd.	BP Vanellus	10W	20W/20	30
	BP Vanellus	10W/30	10W/30	10W/30
Chevron Oil Co.	RPM DELO Multi service Oil	10W	20W/20	30
Cities Service Oil Co.	CITGO Extra Range	10W	20W/20	30
Continental Oil Co.	CONOCO TRACON OIL	10W	20W/20	30
Gulf Oil Corporation	Gulflube Motor Oil X.H.D.	10W	20W/20	30
Mobil Oil Company	Delvac 1200 Series	1210	1220	1230
Shell Oil Company	Shell Rotella T Oil	10W	20W/20	30
Sun Oil Company	Subfleet MIL-B	10W	20W/20	30
Texaco, Inc.	Ursa Oil Extra Duty	10W	20W/20	30

## YOUR NOTES

[www.torresen.com](http://www.torresen.com)

## ENGINE OVERHAUL

The following sections contain detailed information relating to the proper operation characteristics of the major components and systems of the engine. Included are disassembly, rework and reassembly instructions for the guidance of suitably equipped and staffed marine engine service and rebuilding facilities. The necessary procedures should be undertaken only by such facilities.

Additional operating characteristics are included in the Operation Section of this manual.

Any replacements should be made only with genuine Westerbeke parts.

### ENGINE DISASSEMBLY

Take the following precautions:

- A. Clean the exterior of the engine of any deposits of dirt and oil.
- B. Be careful not to damage each disassembled component part.
- C. Arrange parts in the order of disassembly. Mark or label parts as needed to insure proper mating and reassembly. Keep parts clean.

- 1. Mount the engine on a suitable engine stand for disassembly.

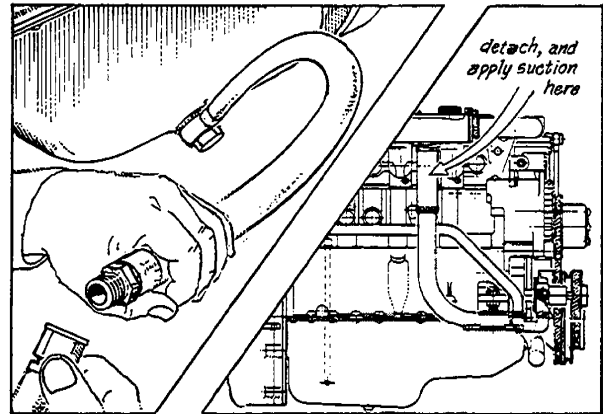

- 2. Drain the engine oil and coolant from the engine and heat exchangers.

- 3. Drain all lubricant from the transmission.

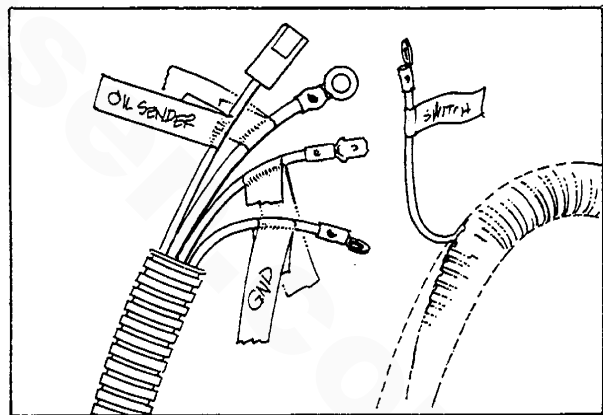

- 4. Remove engine wiring harness in its entirety. Label terminal connections to insure proper reattachment.

- 5. (a) Remove marine transmission and related hardware.
- (b) Remove starter motor.
- (c) Remove engine heat exchanger and engine oil cooler. If possible, leave one end of each hose connection attached to the part being removed.
- (d) Remove engine bellhousing.

- (e) Remove transmission damper plate.
- (f) Remove flywheel.

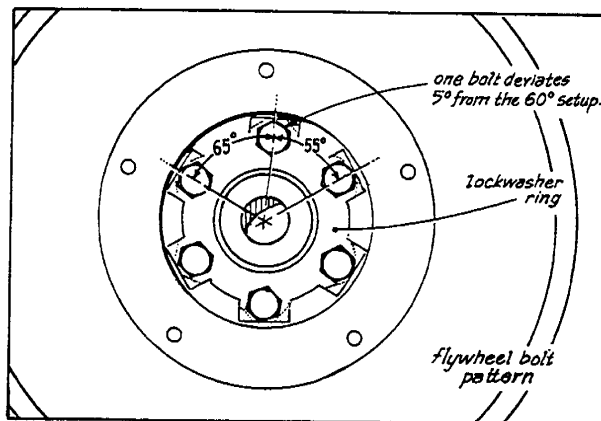
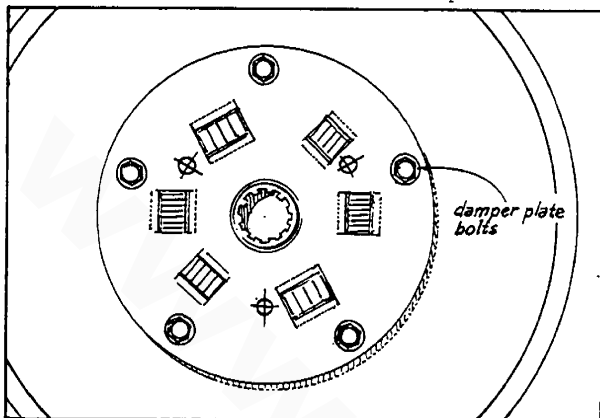

6. Remove engine backing plate.

7. Unbolt elbows at head and remove the exhaust manifold in its entirety.

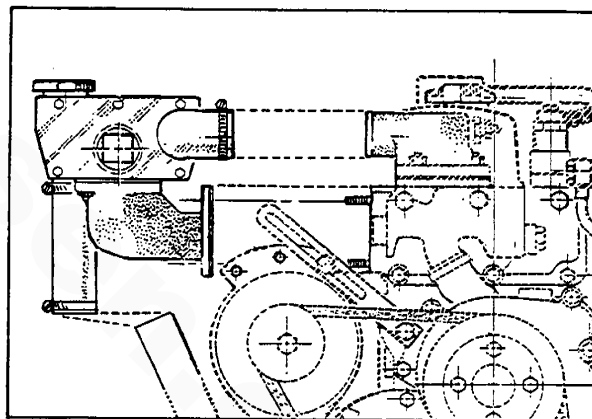

- 8. Remove the engine alternator and sea water pump.
- 9. Remove the engine mounted fuel filter and fuel line to injection pump. (Note arrangement of sealing washers on banjo bolts at fuel filter and injection pump.)
- 10. Remove the thermostat cover and the thermostat. Leave temperature sending unit in place.
- 11. Remove the fresh water circulating pump.



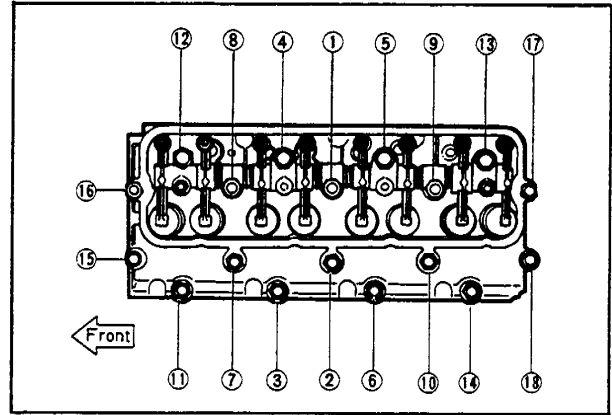
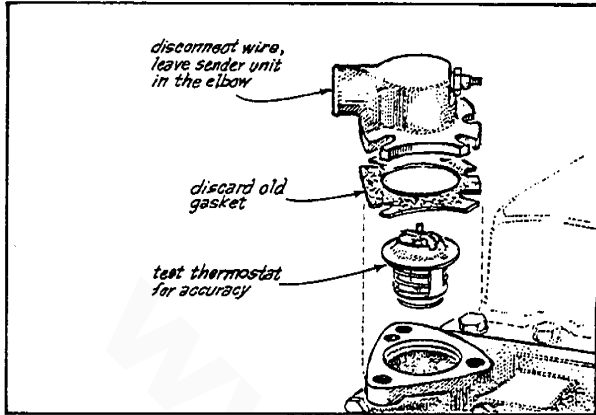

12. Remove the air intake silencer.

13. Remove all the high pressure injector lines from the injection pump to the injectors. Leave the two upper line clamps in place.

Note: Cap ends of the lines and the connections at the injection pump and at the injectors to prevent entry of foreign material.

14. Remove the intake manifold.

15. (a) Remove the fuel return line from the top of the injectors and from the fuel injection pump. (Note washer arrangement on fuel return line banjo bolts. Cap all openings on fuel return line, injectors and injection pump.)

(b) Remove the fuel injectors, dust seals and sealing washers from the cylinder head.

(c) Remove the glow plugs.

16. Remove the crankcase breather hose and rocker arm cover.

17. Remove the cylinder head.

Note: Loosen the cylinder head bolts equally and gradually in the order shown in the figure.

(a) Remove the rocker arm assembly.

(b) Remove the valve stem caps so as not to lose them when removing the cylinder head. Label each cap as to which valve it belongs.

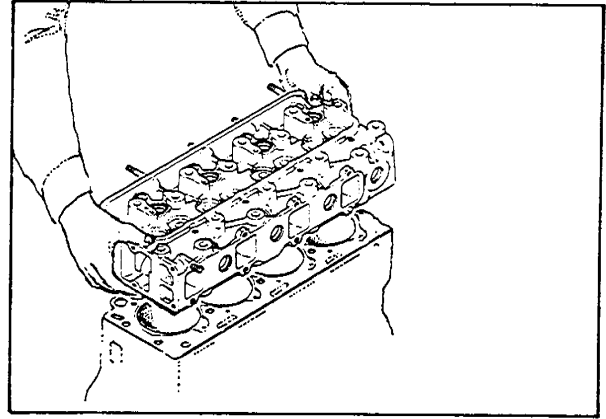
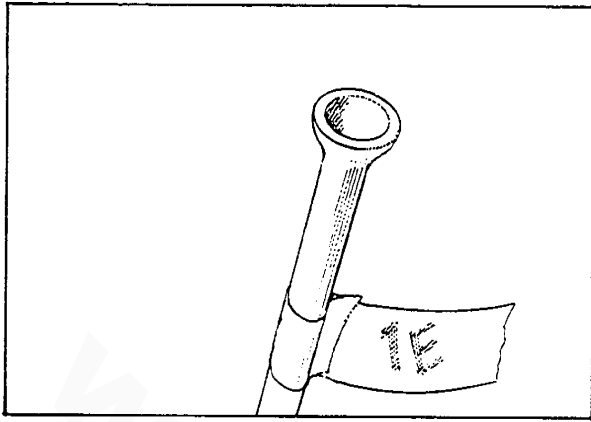

- (c) Remove the push rods. Label each rod as to which valve it belongs.
- (d) Lift the cylinder head off the engine.

18. Remove the oil filter assembly.

19. Removal of the injection pump:

Note: Scribe mating marks on pump body flange and the timing gear case before removal.

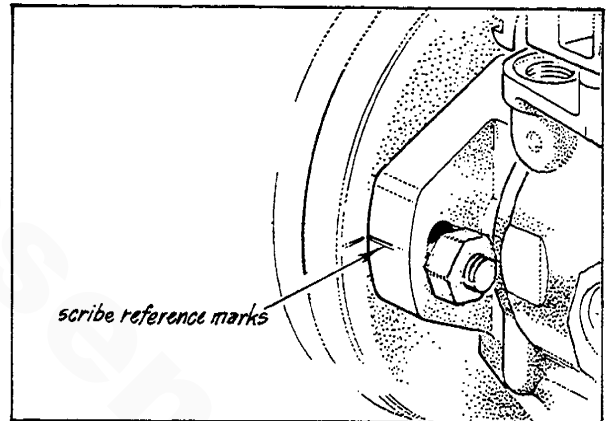

- (a) Remove the cover (1) and the lock nuts (2).

(b) Loosen the two injection pump hold down nuts (3). Do not remove entirely. The hold down nut on the engine side of the pump can be gotten at by using a 1/4" universal socket and extension with ratchet.

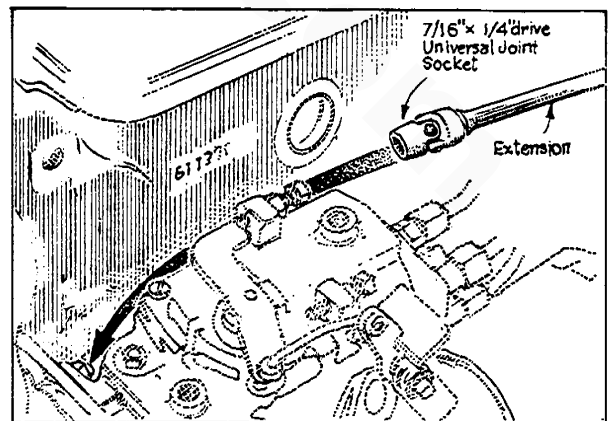

- (c) Remove the nut (4) and lockwasher (5) from the injection pump shaft.

Note: Take care not to drop nut and washer into timing gear case.

(d) Place the keyway on the injection pump shaft in the 12:00 position with the aid of the front crankshaft pulley bolt before attempting to remove the injection pump.

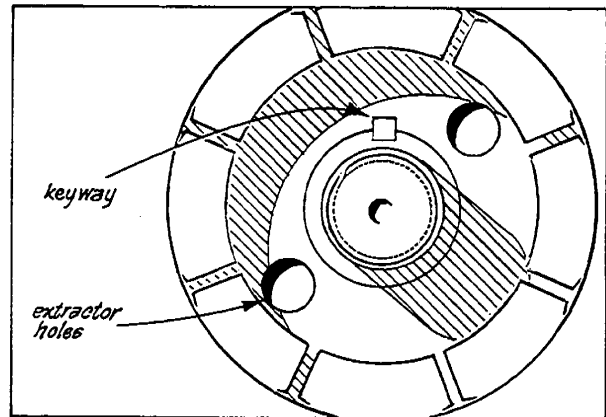

(e) With the use of extractor #49 SE01 157 apply sufficient pressure to loosen the pump from the keyed gear. The loose hold down nuts will prevent the pump from falling from the engine.

Note: If an extractor is not available, replace the nut on the injection pump shaft loosely and with a nylon drift and hammer gently tap the injection pump shaft to dislodge it from the keyed drive gear.

(f) Once loosened, remove the hold down nuts (3) and washers and carefully withdraw the pump from the drive gear and engine so as to avoid losing the injection pump drive key inside the timing case.

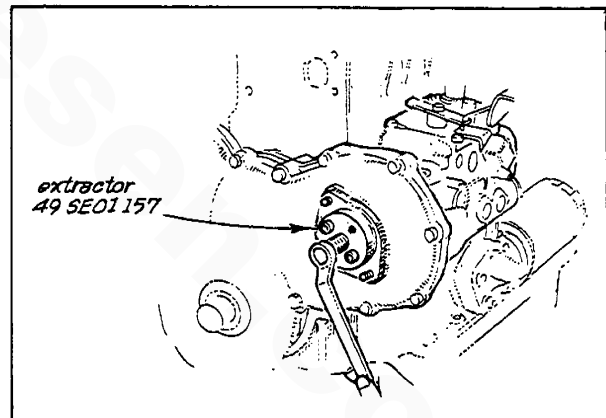

20. Remove the front crankshaft pulley attachment bolt with the aid of a 38 mm socket and draw the pulley off the front crankshaft.
21. Remove the front timing gear cover.
22. Remove the injection pump drive gear (1) and the oil baffle plate (2).
23. Remove the central idler gear and idler gear spindle.

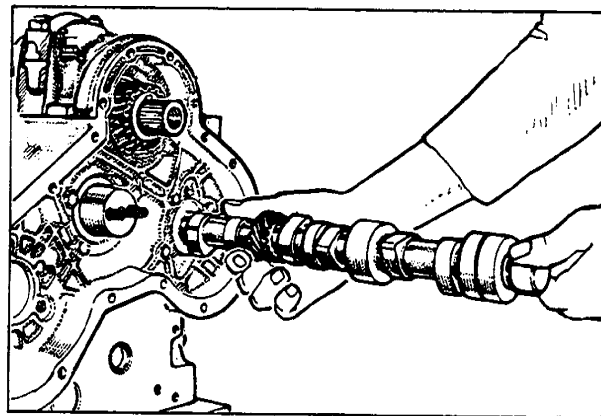
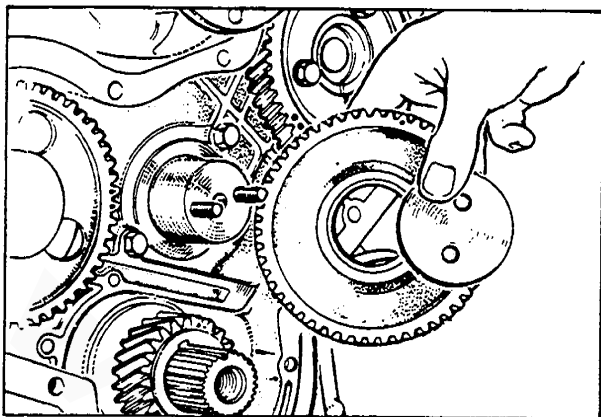

24. With a suitable puller remove crankshaft gear and key.
25. Remove camshaft gear using a suitable puller.
26. Turn the engine over and remove the oil pan.
27. Loosen the set screw (1), then remove the oil pump assembly.
28. Remove the camshaft carefully. Insure that all the pushrod tappets are seated into the engine block prior to attempting to remove the camshaft from the block.

29. Remove the timing gear case from the front of the engine block. Discard the old gasket.

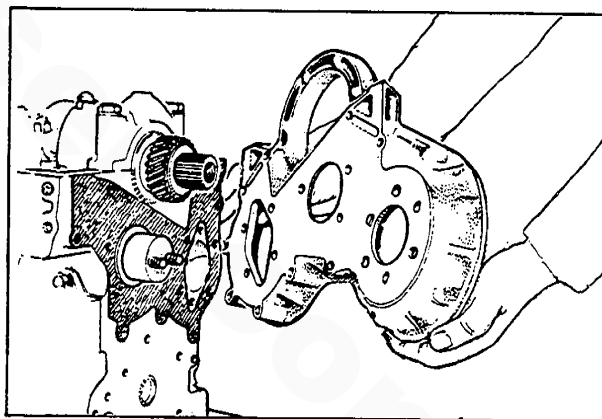

30. Remove the rear oil seal.
31. Remove the connecting rod bearing caps.
32. Remove the piston and connecting rod assemblies from the top of the cylinder block.
33. Remove the main bearing caps.

Note: Mark bearing caps to insure proper reassembly.

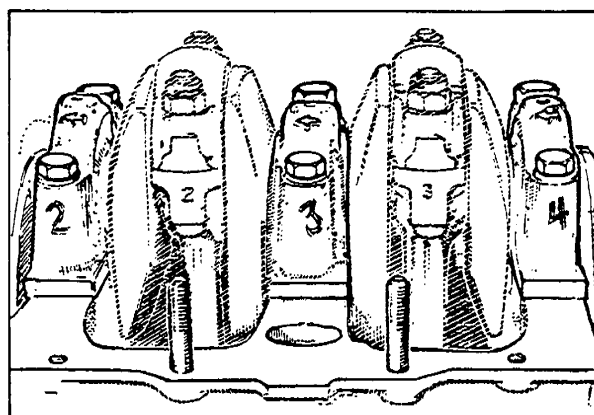
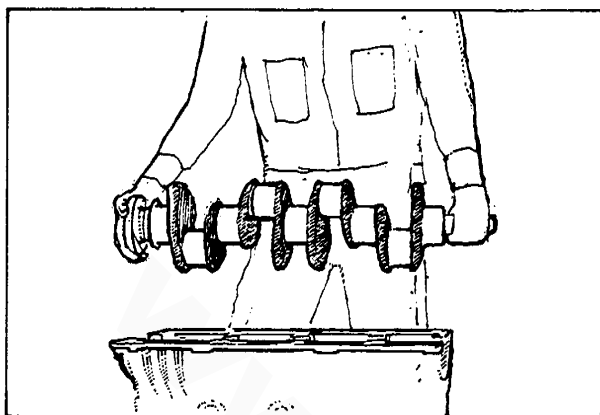

34. Remove the crankshaft.

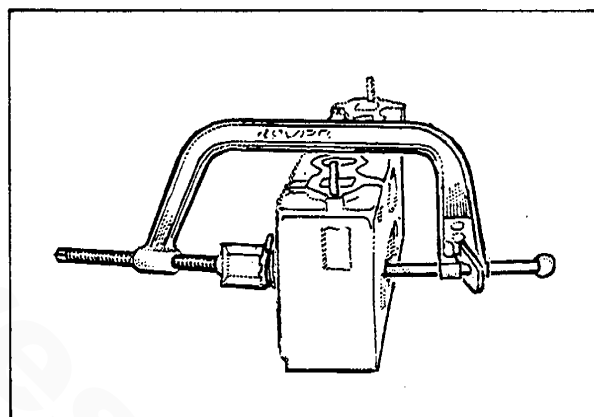

35. Remove each valve from the cylinder head assembly. Use appropriate valve spring compressor to aid in disassembly. Arrange or label valves so as to replace them in the cylinder and guide from which they were removed.

36. Disassemble the rocker arm assembly.

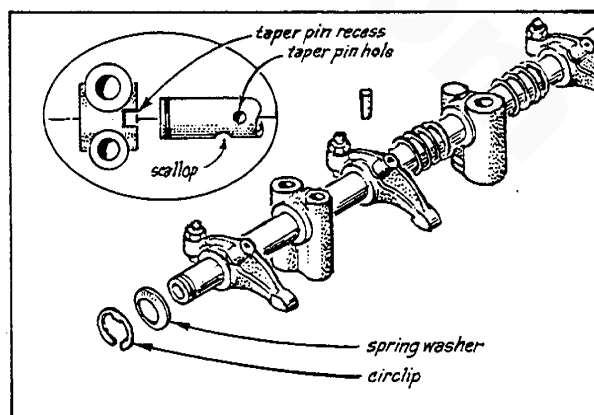

37. Disassemble the piston assembly.

(a) Using the piston ring remover, remove the piston rings.

(b) Remove the wrist pin snap rings.

(c) Using a nylon drift, drive the wrist pin from the piston and rod.

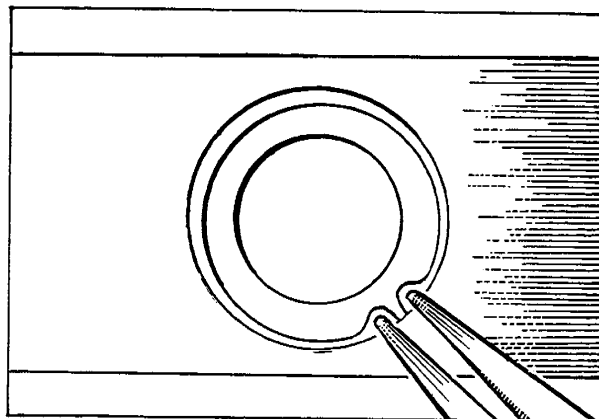

Note: If the piston pin is tightly fitted, heat the piston head with the aid of a hot plate or similar device.

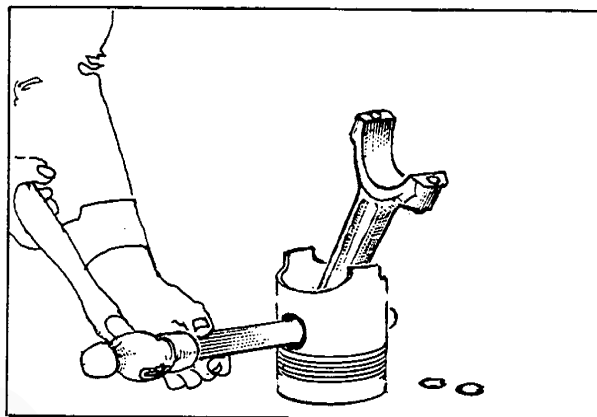

ENGINE INSPECTION AND REPAIR

Cylinder Head

1. Visual inspection  
Check the cylinder head for cracks or any other damage and, if necessary, repair or replace it.
2. Distortion inspection  
(a) Measure the cylinder head surface distortion with a straight edge and the thickness gauge. Take 6 measuring positions as shown in the figure.  
(b) If the distortion exceeds permissible limit, replace the cylinder head. (The head has no allowance for planing and must be replaced, not renewed.)

Distortion limit: 1,2.....0.10 mm (0.004 in)  
3,4,5,6.....0.25 mm (0.010 in)

3. Insert inspection  
Check for cracks or damage on the insert and, if detected, replace it.

4. Insert replacement:  
(a) To remove the insert, place a suitable drift into the injection nozzle hole, then tap the drift with a hammer.  
(b) To install, set the insert in position and insert the welch washer into the insert guide hole. Secure the welch washer by tapping the raised center of the welch washer.

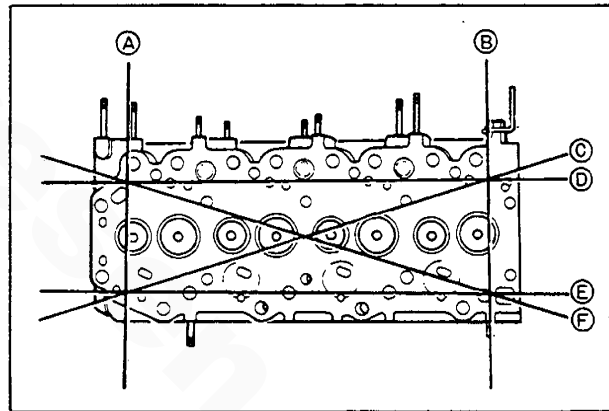

Note:

- (1) Use new welch washer.
- (2) Insert the welch washer so that its convex surface is toward the cylinder head gasket side.
- (3) After installation, check to see if the insert is completely fixed in place.

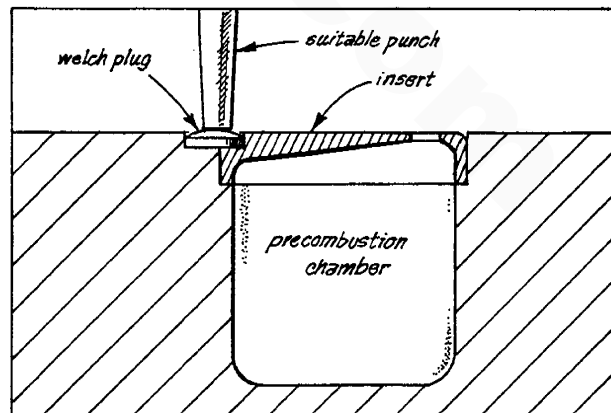

Valve Seat

Note: Valve seat inserts cannot be fitted to this engine.

1. Valve seat angle  
(a) Valve seat angle is 45° and 30° respectively for intake and exhaust sides. The standard contact width of valve seat is 2.0 mm (0.08 in) for both intake and exhaust sides.  
(b) If the valve margin is less than the permissible limit, replace the valve.

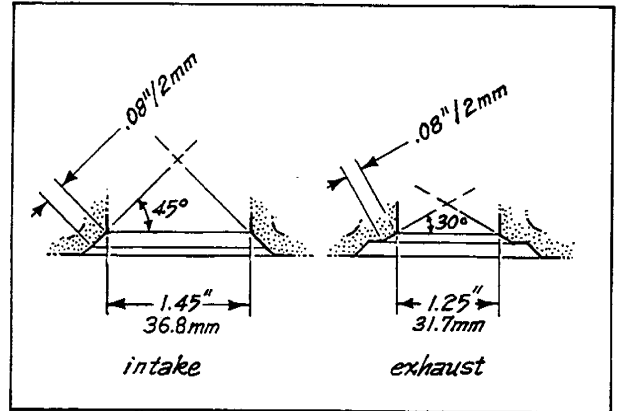

Valve margin limit: 1.35 mm (0.053 in)

2. Stem wear inspection  
If the valve stem is bent or its diameter is less than the limit, replace the valve.

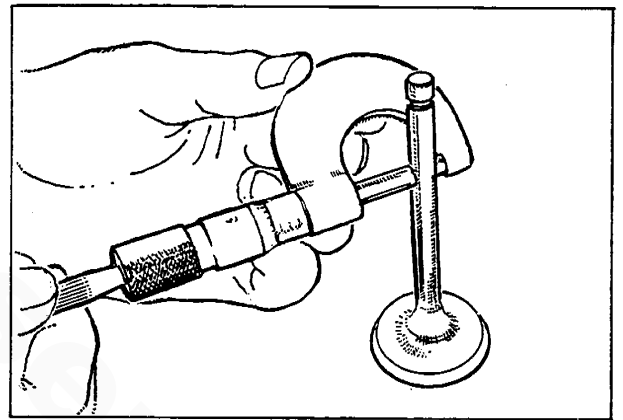

Stem diameter limit:  
Intake.....7.880 mm (0.3102 in)  
Exhaust.....7.867 mm (0.3097 in)



Valve Spring

1. Free length check  
Measure the free length of the valve spring and if free length is less than the limit, replace it.

Limit:

Inner spring: 43.6mm (1.717 in)

Outer spring: 52.9mm (2.083 in)

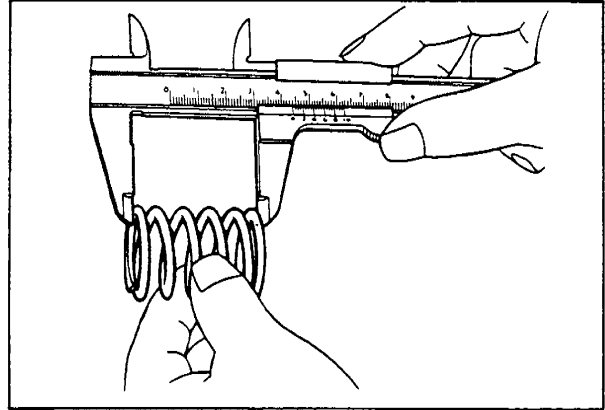

2. Squareness check  
Check the squareness of the valve spring and, if it is more than the limit, replace the spring.

Limit:

Inner spring: 1.25mm (0.049 in)

Outer spring: 1.37mm (0.054 in)

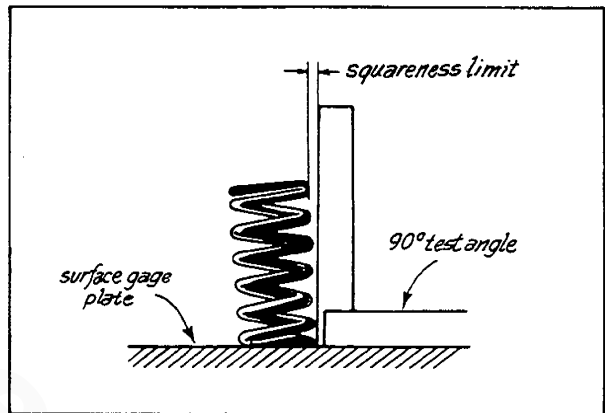

3. Fitting pressure check  
Check the valve spring fitting pressure with a valve spring tester and, if the pressure is less than the limit, replace the spring.

Note: Measure the fitting pressure after compressing the spring several times.

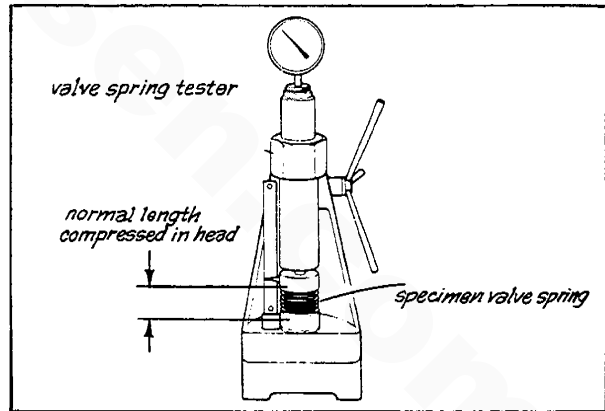

Inner spring

Outer spring

Fitting length	37.8 mm (1.49 in)	40.3 mm (1.59 in)
Fitting pressure limit	10.3 kg (22.7 lb)	14.5 kg (32.0 lb)

### Valve Guide

1. Inspecting clearance between valve and guide:  
Check the clearance between the valve stem and the valve guide. If the clearance is more than the limit, replace the valve or valve guide.

Limit: 0.127 mm (0.005 in)

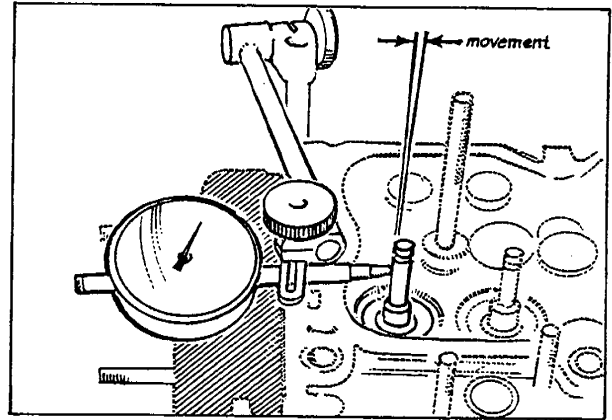

2. Valve guide replacement
  - (a) To remove the valve guide, press out the valve guide towards the combustion chamber side, using the valve guide installer.
  - (b) Using the valve guide installer, press in the valve guide into the cylinder head until the valve guide height reaches the indicated scale on the valve guide installer.

Note: Be sure to press in the valve guide so that the inside chamber on the valve guide end faces to combustion chamber side.

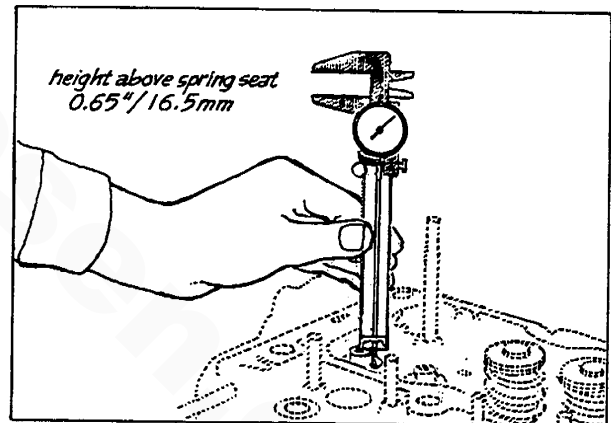
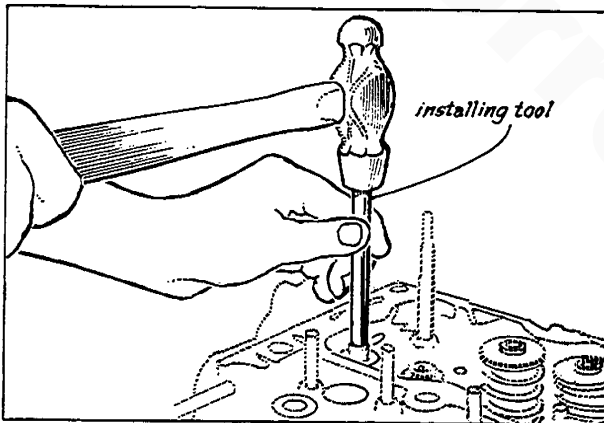

Valve guide remover and installer tool #49 0636 165A  
#49 0636 165

### Rocker Arm

1. Visual inspection
  - (a) Check each component part of rocker arm assembly for cracks or other damage.
  - (b) Check if oil passages of rocker arm and shaft are clogging and, if necessary, repair or replace it.
2. Inspecting clearance between rocker arm and shaft  
Check the clearance between the rocker arm and shaft and, if it exceeds the limit, replace the rocker arm bushing or shaft.

Clearance: Standard - 0.016-0.061 mm (0.0006-0.0024 in)  
Limit - 0.07 mm (0.003 in)

3. Rocker arm bushing replacement
  - (a) Using the suitable mandrel, press out the bushing.
  - (b) Aligning the oil passages of the rocker arm and bushing, press the bushing into the rocker arm.
  - (c) After the rocker arm bushing has been replaced, ream the bushing bore with a reamer so that the clearance between the bushing and shaft becomes equal to the standard clearance.

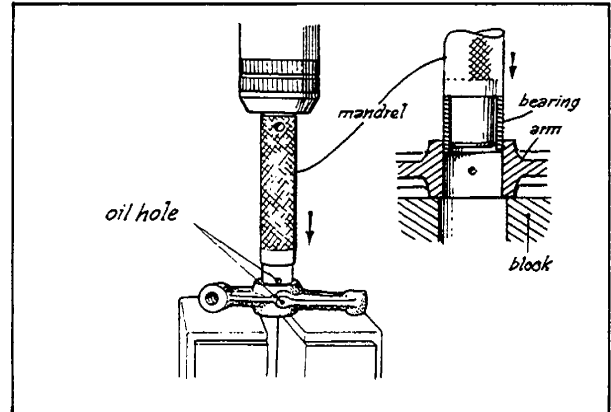

### Tappet

1. Visual inspection
  - (a) Check the tappet for cracks and other damage and, if damaged, replace the tappet.

(b) Check for abnormal wear of portion of tappets that contact with cam, and if any one is abnormally worn, replace the tappet.

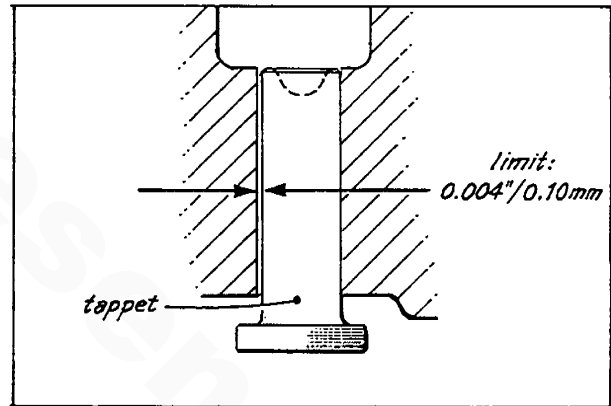

2. Inspecting clearance between tappet and tappet bore  
Check the clearance between the tappet and tappet bore and, if the clearance is greater than the limit, replace the tappet or cylinder block.

Clearance Limit: 0.10 mm (0.004 in)

Cylinder Block

1. Visual inspection

(a) Check the cylinder block for cracks and damage. If necessary, repair or replace it entirely.

(b) Check to see that oil or cooling water passages are not clogged and, if clogged, remove with compressed air or a wire probe.

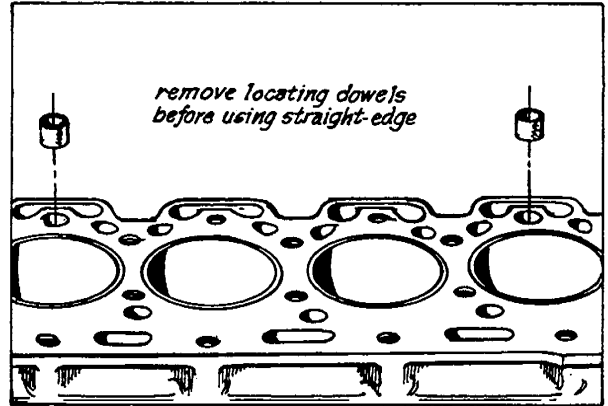

2. Distortion inspection

Check the gasket face distortion of the cylinder block and if it exceeds the limit, repair or replace it.

Distortion limit:

(1) (2) 0.10 mm (0.004 in)

(3) (4) 0.25 mm 0.010 in)

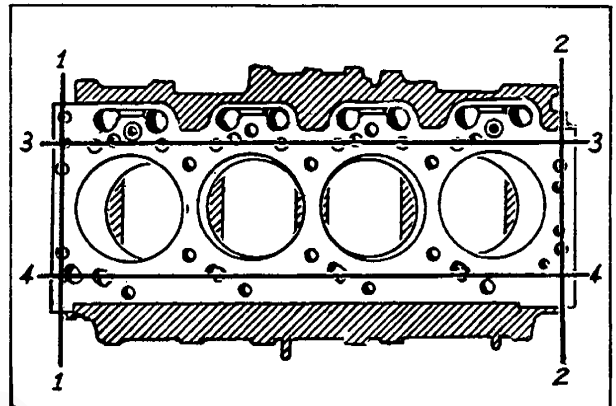

Cylinder Liner

1. Wear inspection

(a) Measure the liner bore at three positions of upper, middle and lower portions with cylinder gauge in X-X' and Y-Y' directions as shown in figure.

(b) If wearing exceeds the limit, replace the liner.

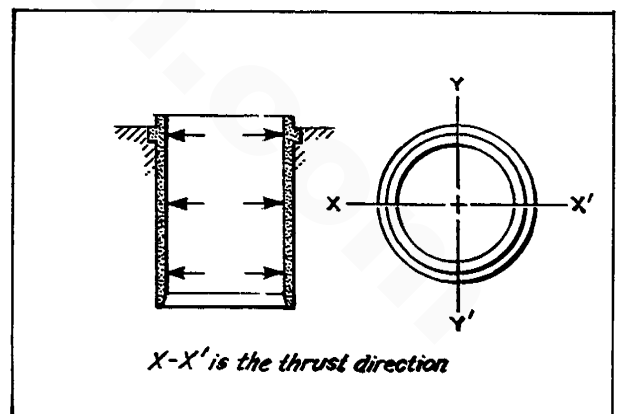

Cylinder liner bore:

Standard 88.925-88.950 mm (3.5010-3.5020 in)

Wear Limit 0.20 mm (0.008 in)

2. Cylinder liner replacement

(Hydraulic press or similar device is needed)

- (a) Attach the cylinder liner puller and installer to the lower rim of the cylinder liner, then press out the liner.
- (b) Check for scratches on the cylinder block side and, if any, remove them by using extremely fine emery paper with engine oil.
- (c) To install the liner, apply the engine oil on the cylinder block bore and the liner exterior, then set the liner on the cylinder block.
- (d) Using the cylinder liner puller and installer, press the liner into the cylinder block.

Note: 1) Press in the liner straight.  
2) When press fitting the liner, keep the pressure within a range of 1-3 tons (2,200-6,600 lb).

- (e) Measure the liner protrusion and correct it if necessary.

Protrusion - 0.101-0.000 mm (0.0040-0.0000 in)

### Piston and Piston Ring

#### 1. Visual inspection

Check the sliding surface and ring groove of piston for wear, scratches or any other damage.

#### 2. Inspecting clearance between piston and cylinder liner

(a) Check the clearance between the piston and the cylinder liner by measuring the cylinder bore and piston diameter and, if the clearance exceeds the limit, replace the cylinder liner or piston.

(b) To measure the piston diameter, measure 18 mm (0.7 in) above from the piston bottom at right angle to the piston pin.

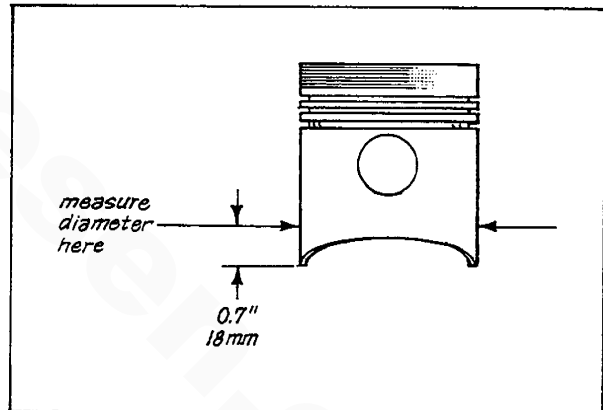

Piston and cylinder clearance	0.044-0.070 mm (0.0017-0.0028 in)
Standard piston diameter	88.872-88.898 mm (3.479-3.500 in)

#### 3. Piston ring inspection

Check the piston ring for breaks, seizure and wear and, if any of these conditions exist, replace the ring.

#### 4. Inspecting clearance between piston ring and ring groove

Check the clearance between the piston ring and the ring groove and, if it exceeds the limit, replace the ring.

Clearance limit: 0.30 mm (0.0118 in)

#### 5. Inspecting piston ring end gap

(a) Position the piston ring into the bottom of the cylinder

liner.

(b) Measure the piston ring end gap and, if it exceeds the limit, replace the ring.

Piston ring end gap limit:

1.5 mm (0.591 in)

Be sure to position the piston ring below the ring sliding surface of the cylinder liner.

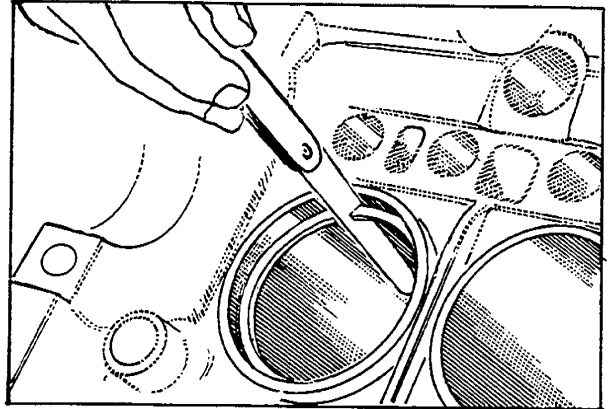

### Connecting Rod

#### 1. Visual inspection

Check the connecting rod for cracks or other damage and, if necessary, replace it.

#### 2. Bend inspection

Using a connecting rod aligner, check the bend and twist of the connecting rod and, if exceeding the limit, repair it with a press or replace it.

Bend limit:

0.05 mm (0.002 in)  
per 100 mm (3.9 in)

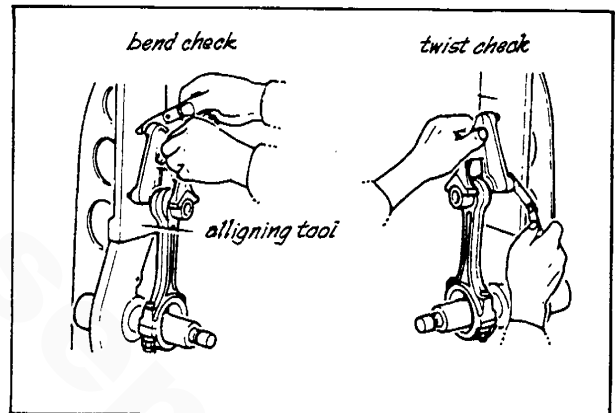

#### 3. Inspecting clearance between the piston pin and small end bushing

Check the clearance between the piston pin and the small end bushing and, if it exceeds the limit, replace the piston pin or small end bushing.

Clearance:

Standard: 0.012-0.039 mm  
(0.0005-0.0015 in)  
Limit: 0.05 mm (0.002 in)

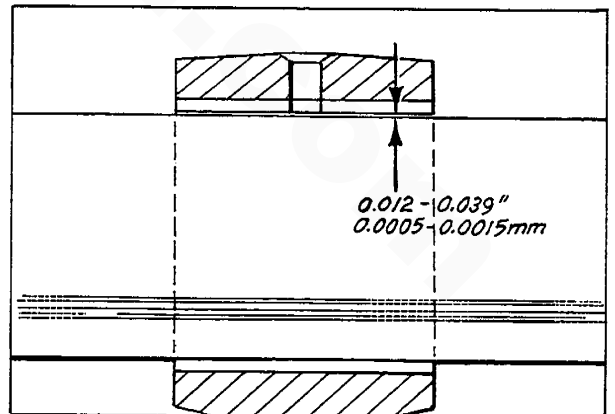

4. Small end bushing replacement
- (a) Using a press, press out the bushing.
  - (b) Align the oil passages of the connecting rod and the small end bushing; press in the bushing to the connecting rod bore.
  - (c) After a small end bushing has been replaced, ream the bushing bore to obtain the specified clearance between the small end bushing and the piston pin.

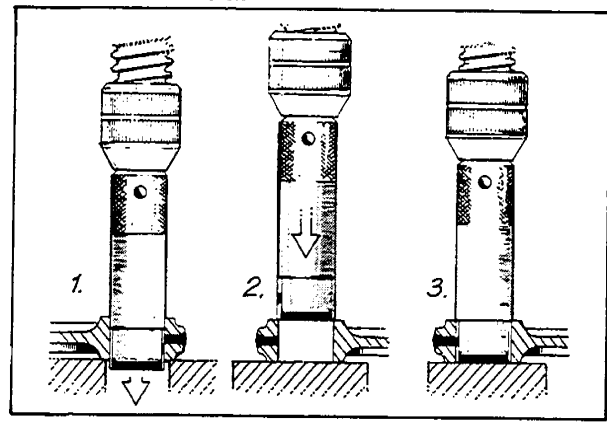

5. Inspecting connecting rod side play
- Check the connecting rod side play with the dial gauge and, if it exceeds the limit, replace the connecting rod and crankshaft.

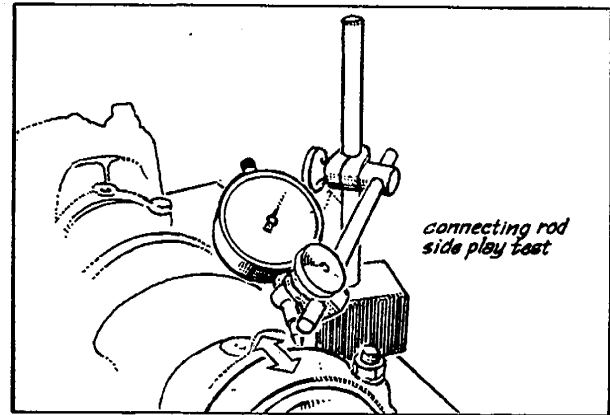

Side play limit: 0.40 mm (0.016 in)

6. Inspecting connecting rod bearing
- Check the connecting rod bearing for peeling and thermal damage. If it is severe, replace the bearing.

7. Inspecting connecting rod bearing clearance
- Using the plastigauge, measure the oil clearance of the connecting rod bearing and, if it exceeds the limit, replace the connecting rod bearing.

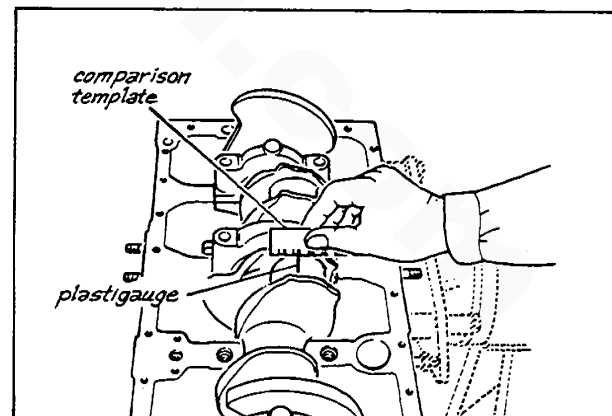

Connecting rod cap

Tightening torque: 7.8-8.0 m-kG (56-58 ft-lb)

Oil Clearance

Standard: 0.012-0.031 mm (0.0005-0.0012 in)

Limit: 0.05 mm (0.002 in)

Crankshaft

1. Visual inspection

- (a) Check the crankshaft for cracks or other damage. If necessary, replace the crankshaft.
- (b) Check for clogging of oil passages and, if clogged, remove with compressed air or wire.

2. Runout inspection

Check the crankshaft runout and, if it exceeds the limit, replace the crankshaft.

Runout limit: 0.05 mm  
(0.0012 in)

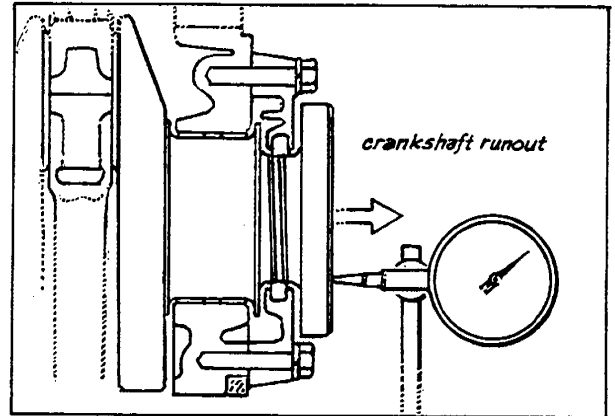

3. Inspecting crank pin and journal

Measure the diameter of each crank pin and crankshaft main journal and, if the diameter is less than the limit, refinish the crank pin and main journal to size for the next undersize bearing.

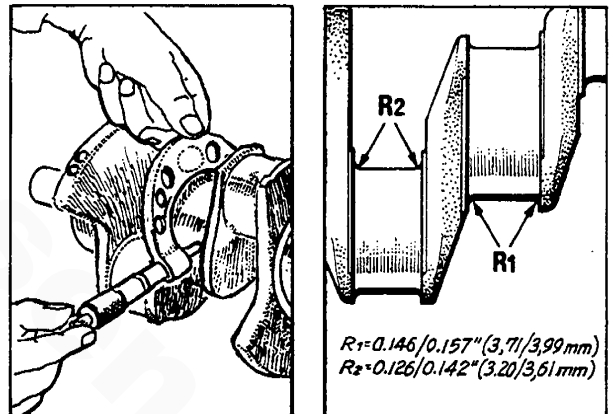

Crank pin standard diameter  
57.112 - 57.125 mm  
(2.2485 - 2.2491 in)

Wear limit  
0.05 mm  
(0.002 in)

Main journal standard diameter  
69.812 - 69.825 mm  
(2.7485 - 2.7491 in)

Wear limit  
0.05 mm  
(0.002 in)

Note:

- (1) For the measurement on both crank pin and main journal, measure them at vertical and horizontal directions on front and rear places.
- (2) When refinishing the crankshaft, finish "R" portion as shown in the figure.
- (3) Refer to the table for refinishing dimensions of crankshaft where undersize bearing is used.



Undersize bearing	Crank pin diameter
0.254 mm (0.01 in)	56.868-56.871 mm (2.2389-2.2391 in)
0.508 mm (0.02 in)	56.604-56.617 mm (2.2285-2.2312 in)
0.762 mm (0.03 in)	56.350-56.363 mm (2.2185-2.2191 in)

Undersize bearing	Main journal diameter
0.254 mm (0.01 in)	69.558-69.571 mm (2.7385-2.7391 in)
0.508 mm (0.02 in)	69.304-69.317 mm (2.7182-2.7291 in)
0.762 mm (0.03 in)	69.050-69.063 mm (2.7185-2.7191 in)

4. Inspecting crankshaft end play  
 Check the end play of the crankshaft and, if the end play exceeds the limit, replace the thrustwasher with 0.178 mm (0.007 in) over-size.

Standard: 0.14 - 0.39 mm (0.0055 - 0.0153 in)  
 End play limit: 0.40 mm (0.0157 in)

5. Inspecting main bearing  
 Check the main bearing for peeling, seizure or fusion and, if necessary, replace the bearing.

6. Inspecting main bearing clearance  
 Using the plastigauge, measure the oil clearance and, if it exceeds the limit, replace the main bearing.

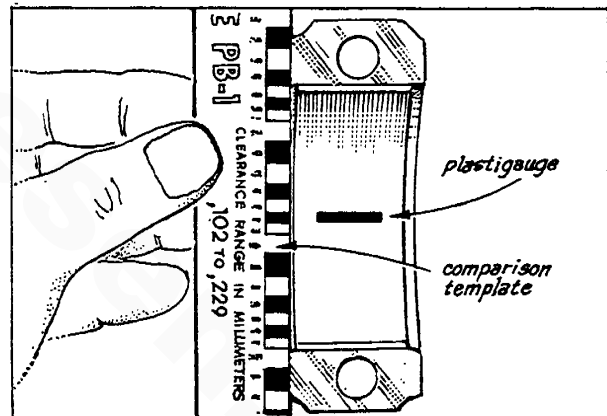

Main bearing cap:  
 Tightening torque: 11.0-11.7 m-kg (80-85 ft-lb)

Oil clearance:  
 Standard: 0.059-0.090 mm (0.0020-0.0040 in)  
 Limit: 0.12 mm (0.005 in)

### Camshaft

1. Visual inspection  
 Check the camshaft for cracks and damage. If necessary, replace the camshaft.

2. Inspecting cam height  
Measure the cam height and, if it is less than the limit, replace the camshaft.

Cam height limit:

42.478 mm (1.6724 in)

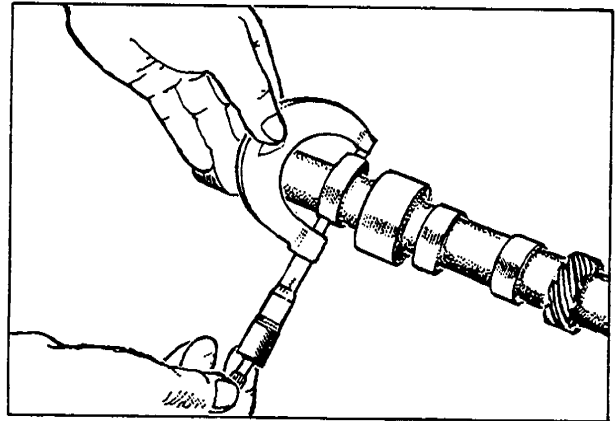

3. Inspecting camshaft journal  
Check the camshaft journal and, if wearing exceeds the limit, replace the camshaft.

	Diameter of Journal	Wear Limit
No. 1	51.910 - 51.940 mm (2.0437 - 2.0449 in)	
No. 2	51.660 - 51.690 mm (2.0339 - 2.0351 in)	0.008 mm (0.0003 in)
No. 3	51.410 - 51.440 mm (2.0240 - 2.0252 in)	
No. 4	51.160 - 51.190 mm (2.0142 - 2.0154 in)	

4. Inspecting camshaft oil clearance  
Check the oil clearance of camshaft by measuring the camshaft bore in the cylinder block and camshaft journal diameter. If the oil clearance is more than the limit, replace the camshaft or cylinder block.

Oil clearance limit: 0.145 mm (0.0057 in)

5. Inspecting camshaft runout  
Check the camshaft runout and, if it exceeds the limit, replace the camshaft.

Runout limit: 0.08 mm (0.003 in)

6. Camshaft front bearing replacement
  - (a) Mount the camshaft assembly in a vise equipped with copper or aluminum plate, then remove the bolt (1), lock plate (2), cam gear (3), thrust plate (4), bearing outer face (5) and key (6).
  - (b) Using a press, press out the bearing.
  - (c) Check the removed parts for wear or other damage and replace the parts as necessary.
  - (d) Install the bearing onto the camshaft with a press.
  - (e) Assemble the thrust plate and camshaft gear onto the camshaft.

Camshaft gear tightening torque: 6.4-9.5 m-kG (46-69 ft-lb)

7. Inspecting camshaft end play  
Measure the end play of camshaft with the thickness gauge and if the end play is more than the limit, replace the thrust plate.

End play limit:

0.3 mm (0.012 in)

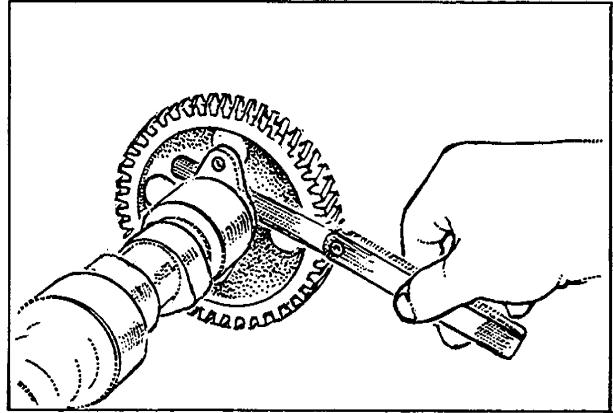

### Idler Gear and Idler Gear Spindle

1. Visual inspection
  - (a) Check the damage on bushing inner surface of idler gear and the spindle sliding surface and, if necessary, replace the idler gear or spindle.
  - (b) Check the oil passage for clogging and, if necessary, clean the passage with compressed air or wire.

2. Inspecting clearance between bushing and spindle  
Check the clearance between the idler gear bushing and the spindle and, if it exceeds the limit, replace the idler gear or spindle.

Clearance

Standard: 0.034-0.084 mm  
(0.0013-0.0033 in)

Limit: 0.15 mm (0.004 in)

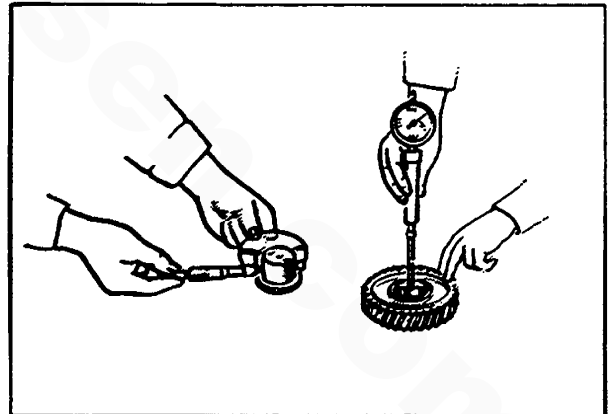

### Gears

1. Visual inspection  
Check each gear tooth for cracks or other damage.

2. Inspecting end play of idler gear

Check the end play of the idler gear and, if it exceeds the limit, replace the thrust plate or idler gear.

Thrust plate idler gear  
tightening torque:

2.3-3.2 m·kg (16.6-23.1 ft·lb)

Standard end play:

0.15-0.30 mm (0.0059-0.0118 in)

3. Inspecting backlash between gears

Check the backlash between each gear and, if it exceeds the limit, replace the gears.

Note: Before inspecting the backlash, check the end play of the idler gear and clearance between the idler gear bushing and spindle.

Standard: 0.10 - 0.17 mm (0.004 - 0.007 in)

Backlash limit: 0.30 mm (0.012 in)

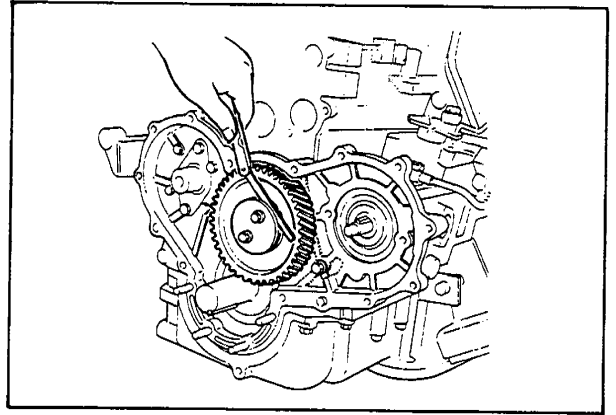

Push Rod

1. Visual inspection

Check the push rod for damage on both ends. If it is severe, replace it.

2. Bend inspection

Check the push rod for bend and, if it exceeds the limit, replace it.

Bend limit: 0.19 mm (0.0075 in)

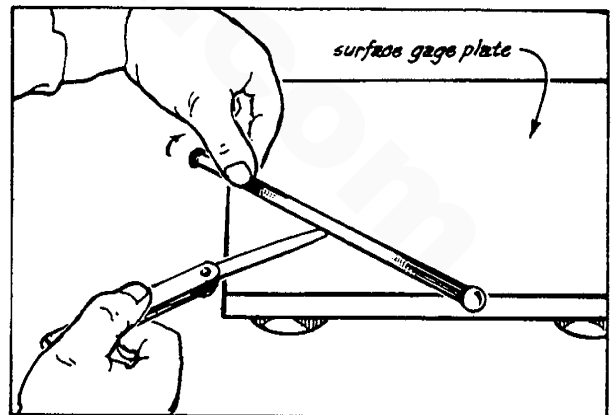

### Timing Gear Cover

1. Inspecting timing gear cover  
Check the timing gear cover and oil seal for any damage. If necessary, replace the cover or oil seal.

2. Oil seal replacement
  - (a) To remove the oil seal, use the oil seal puller and installer and pull out the oil seal.
  - (b) To install, apply the engine oil on the outer periphery of the oil seal, then press in the oil seal with oil seal puller and installer.

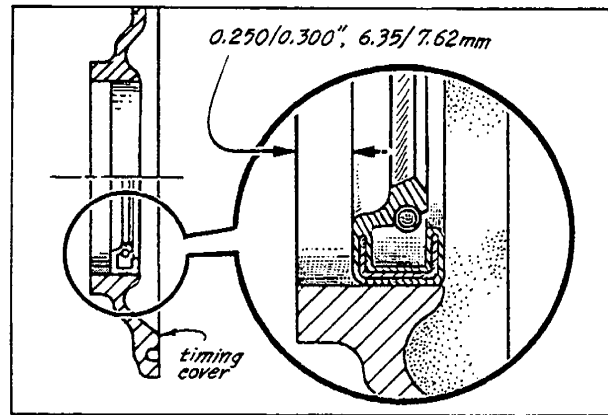

### Rear Oil Seal

1. Inspecting oil seal  
Check the oil seal lip for wear or other damage and, if necessary, replace it.

2. Oil seal replacement
  - (a) Upon inspection, finding the existing seal worn or frayed, pick the old seal halves out of their grooves and thoroughly clean the half-housings.
  - (b) With half-housing held in a soft-jawed vise and the seal recess uppermost, settle one inch (25 mm) of the seal wick at each end into the groove. Make certain that each end of the seal projects 0.010/0.020 inches (0.25/0.51 mm) beyond the joining faces of the two-piece housing.

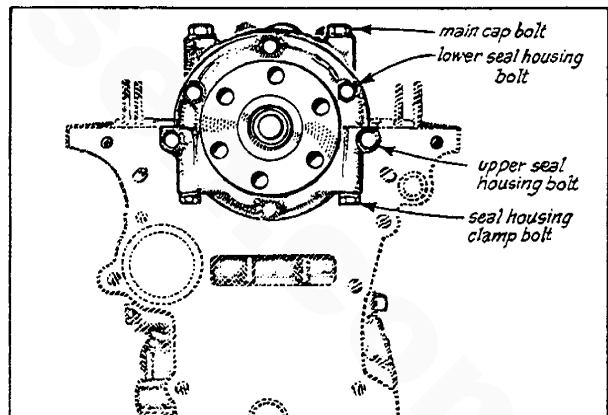

- (c) Press the remainder of the seal wick into the groove starting from the center and working outwards.
- (d) Using a suitable round bar, roll and press the seal into place in both half-housings.

To refit the assembly:

- (a) Thoroughly clean the butt joint between the half-housings.
- (b) Lightly coat the butt joint faces with a liquid gasket com-

pound similar to Dow Corning "Silastic 732 RTV" adhesive/sealant. Lubricate the exposed diameter of the wick seals with graphite grease.

(c) Oil the crankshaft at the oil return groove. Place the half-housings in position against the gasket and the engine block and locate all the bolts into the block and bearing cap face finger tight only.

(d) Tighten the clamping bolts to a temporary torque of 0.55 - 0.83 kgf m (4 - 6 lbf ft).

(e) Tighten the bolts in the block and cap to a torque of 1.66 kgf m (12 lbf ft).

(f) Finally, tighten the clamping bolts to a torque of 1.66 kgf m (12 lbf ft).

### Oil Pump

#### 1. Checking

Visually check the disassembled parts and replace faulty parts. Check the sliding surface of pump cover with special care and replace the cover if the surface has steps or excessive streaks. (Minor steps and streaks may be repaired by rubbing them with a compound on a surface plate.

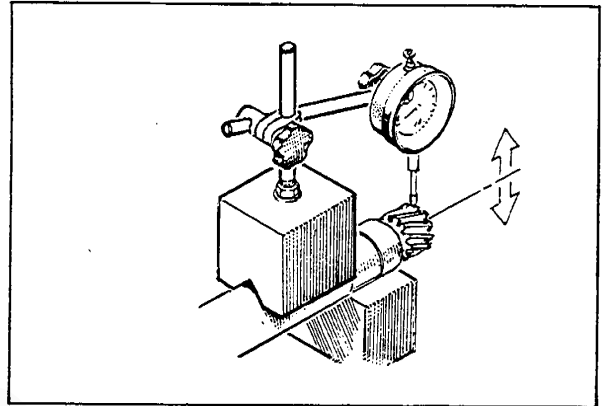

#### 2. Clearance between pump body and shaft

Measure the above clearance with a dial gauge and magnet base.

Clearance limit: 0.1 mm (0.0039 in)

When the clearance exceeds the limit, replace the pump drive shaft inner rotor, pump body and drive gear.

#### 3. Clearance between inner rotor and outer rotor

Check the clearance between the lobes of the rotors with a feeler gauge. If the clearance exceeds the limit, replace both rotors.

Clearance limit:

0.3 mm (0.012 in)

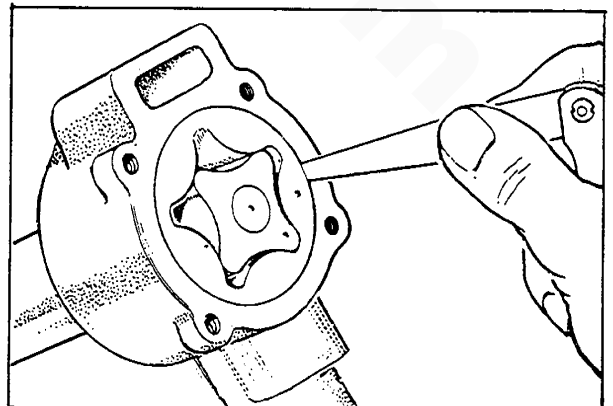

4. Clearance between outer rotor and pump body  
Check the clearance between the outer rotor and pump body with a feeler gauge. If the clearance exceeds the limit, replace the rotor or pump body.

Clearance limit: 0.3 mm (0.012 in)

5. Clearance between rotor and pump cover

Check the end float of the rotors. Place a straight edge across the pump body and measure the clearance between the rotor and straight edge with a feeler gauge. If the clearance exceeds the limit, replace the drive gear, drive shaft, inner rotor, outer rotor and pump body.

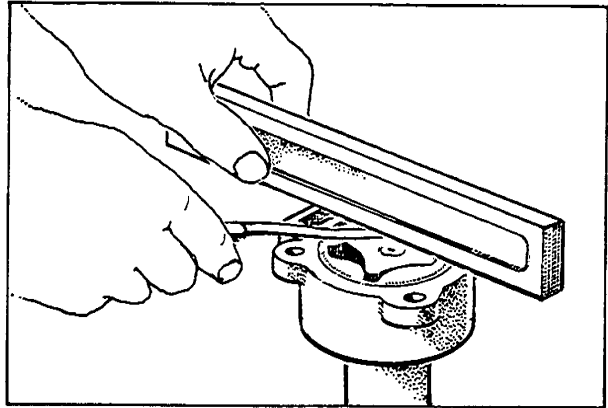

Clearance limit:

0.15 mm (0.006 in)

6. Free length of plunger spring  
Check the relief valve for worn plunger and fatigued spring.

Spring free limit:

40 mm (1.61 in)

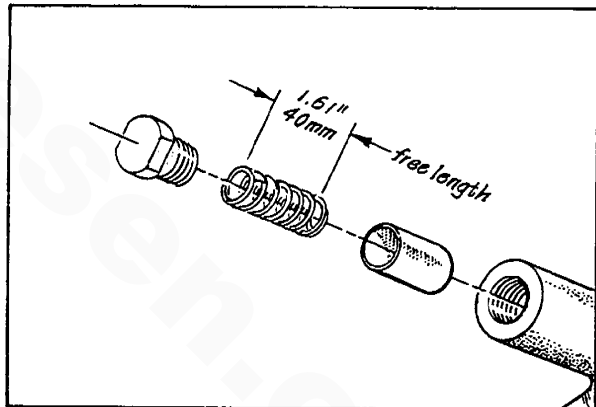

## Assembly

Assemble in the reverse order of disassembly.

Note: When installing the rotors into the body, be sure that the tally marks on the rotors are positioned toward the cover.

Cover tightening torque:

0.8 - 1.2 m-kg  
(5.8 - 8.7 ft-lb)

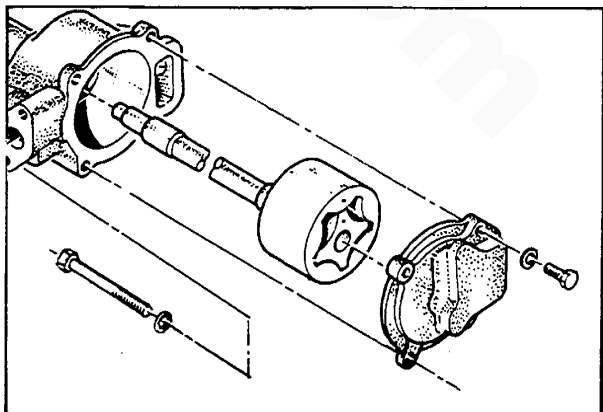

### Installation

Install in the reverse order of removal.

### Oil Pressure

1. Remove the oil pressure sender, then install a mechanical oil pressure gauge instead of the sender.
2. After warming up engine, set the engine speed to 2400 RPM, then read the oil pressure gauge.

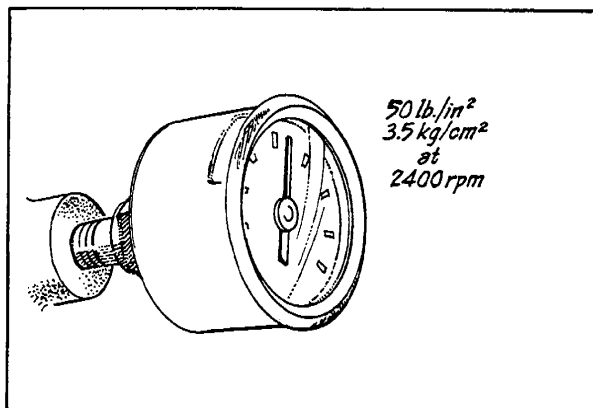

Oil pressure: 3.5 kg/cm<sup>2</sup> (50 lb/in<sup>2</sup>) or more at 2400 RPM



## ENGINE ASSEMBLY

Take the following precautions:

- A. Be careful not to mix bolts and nuts. Metric and S.A.E. bolts are used on various engine assemblies.
- B. During assembly, recheck clearances and insure parts are being assembled in their proper order and facing in the correct direction in relation to the engine block, e.g., pistons, piston rings, bearings and bearing caps.
- C. Apply lubricating oil to moving parts during assembly. Insure that moving parts, when assembled on the engine, rotate or slide and are not subject to binding or excessive tension.
- D. If there are mating marks scribed during disassembly, reference them correctly for assembly.
- E. Use new gaskets, lockwashers, o-rings, etc.
- F. Tighten the bolts and nuts on important parts of engine to specified torques using a reliable torque wrench.
- G. Use liquid sealants when required on nuts, bolts and gaskets. Refrain from using tape sealants.

1. Install the valves in cylinder head.  
Using the valve spring lifter arm and pivot, assemble the valve, lower spring seat, oil deflector, inner valve spring, outer valve spring, upper spring seat and taper sleeve in this order.

Note: The oil deflector should be installed on the intake valve only.

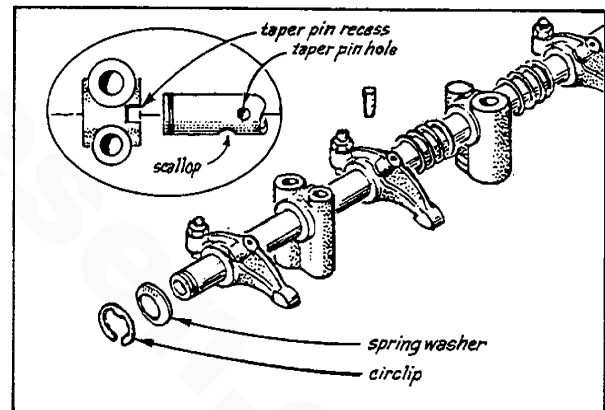

2. Assemble the rocker arm shaft, rocker shaft brackets and rocker arms. Note that the front end of the rocker shaft is identified by a pin protruding from the top and a larger oil hole between the supply holes serving #1 and 2 rocker arms. This pin fits a slot in the #1 rocker shaft support which prevents the shaft from turning and cutting off the lube oil to the rocker arms and valves.

3. Assemble the connecting rod, piston and piston rings.
  - (a) Arrange the piston and the connecting rod as shown in the figure and, using the piston pin installer, insert the piston pin through the piston and connecting rod until the piston pin circlips can be fitted.
  - (b) Fit the piston pin circlips to their respective grooves.

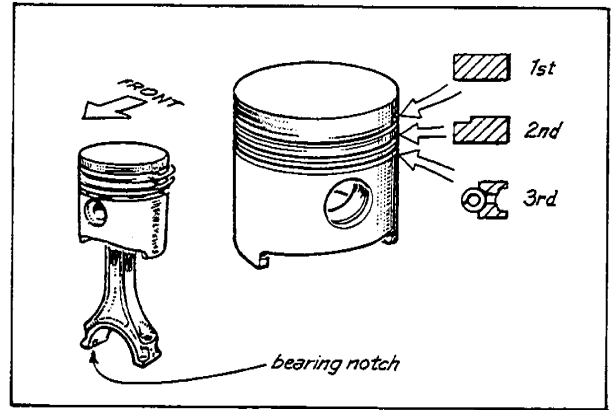

- (c) Install the piston rings to ring grooves on the piston with the inscription mark on ring upward.

4. Install the crankshaft.

Note: Do not apply oil to the backsides of main bearing shells.

- (a) Fit the main bearings on the cylinder block and the bearing caps respectively. Check that the oilways align perfectly with those in the block.

- (b) Fit the thrustwashers to the cylinder block so that the oil grooves on thrustwashers face to crankshaft side.

- (c) Position the crankshaft to the cylinder block, being careful not to drop the thrustwashers as the crankshaft settles into place.

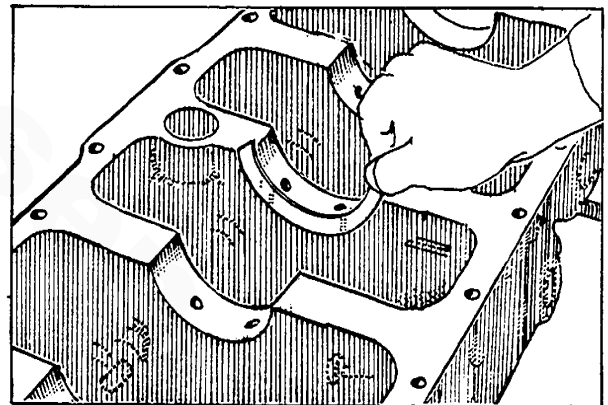

- (d) Fit the thrustwasher to the main bearing cap so that the oil grooves on thrustwasher face to crankshaft side. Then install the main bearing cap to the cylinder block with arrow mark of the main bearing cap facing the crankshaft pulley side.

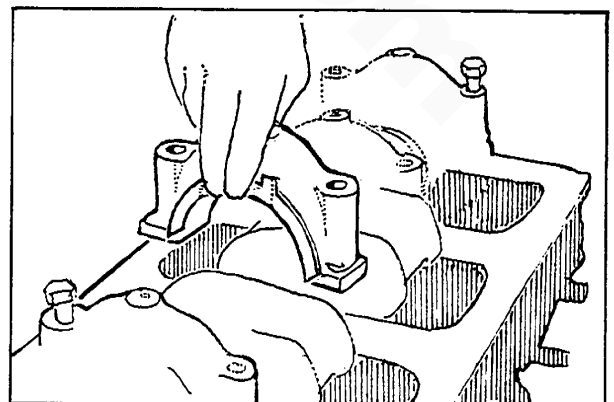

Main bearing cap tightening torque:

11.0-11.7 m-k<sub>g</sub> (80-85 ft-lb)

5. Install the rear oil seal. Apply engine oil to oil seal lip.
6. Install the piston and connecting rod assembly.
  - (a) Place the piston rings so that the ring ends are properly spaced around the circumference of the piston as shown.
  - (b) Using a ring compressor, fit the piston into the cylinder in the position as is shown in Figure

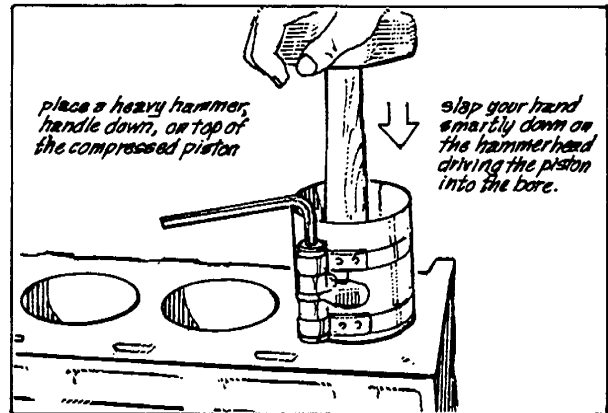
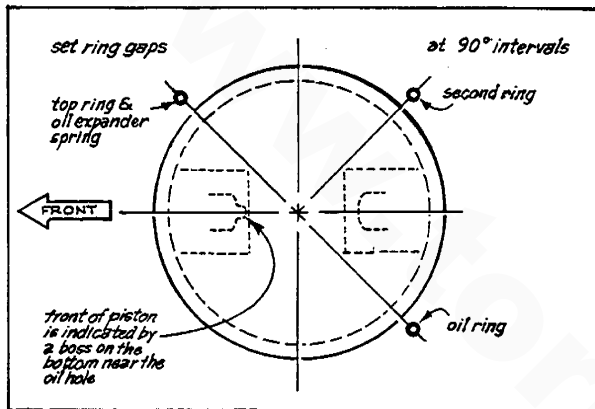

(c) Install the caps to the connecting rods, ensuring that the identification numbers on the cap and connecting rod are matched.

Cap tightening torque:

8.2 - 9.0 m-k<sub>g</sub>  
(59 - 65 ft-lb)

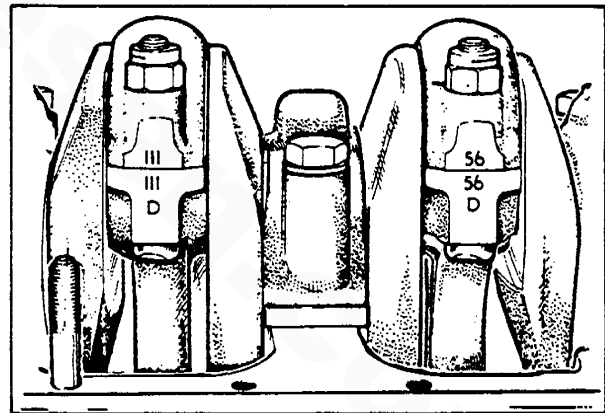

7. Install the idler gear spindle. Align the oil passages of the idler gear spindle and cylinder block.
8. Install the timing gear case. Attach the straight edge on the cylinder block, then match the surfaces of the timing gear case end and that of the cylinder block. If the gasket protrudes from the mating surface, cut away the excess with a knife.

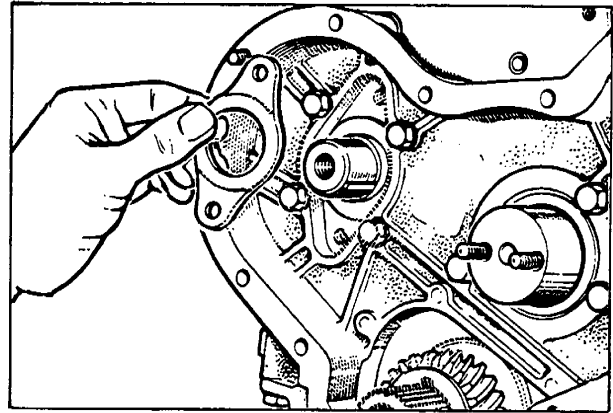
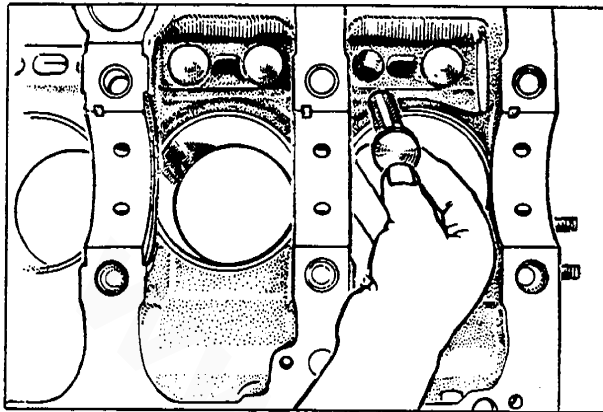

9. Installation of the crankshaft
- (a) Insert the tappet into the cylinder block.
  - (b) Insert the camshaft into the cylinder block.
  - (c) Install the camshaft thrust plate.

Thrust plate tightening torque:

1.6-2.4 m-kg  
(11.6-17.4 ft-lb)

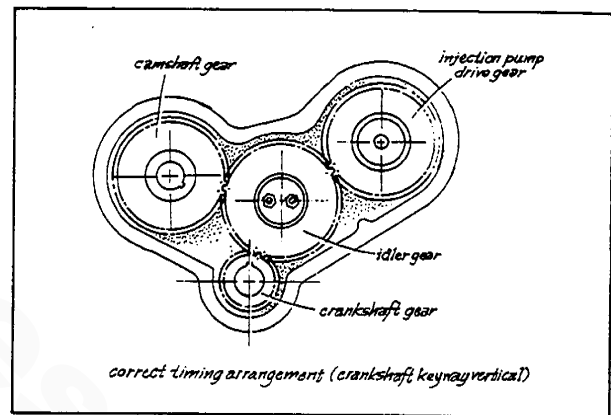

10. Install each gear.
- (a) While aligning the timing mark of each gear, install the following gears on each position.
    - (1) Timing gear
    - (2) Cam gear
    - (3) Idler gear
    - (4) Injection pump drive gear
  - (b) Install the idler gear thrust plate, then tighten the nuts.

Tightening torque: 2.3 - 3.2 m-kg (16.6 - 23.1 ft-lb)

- (c) Tighten the camshaft gear attaching bolts.

Tightening torque: 6.4 - 9.5 m-kg (45 - 51 ft-lb)

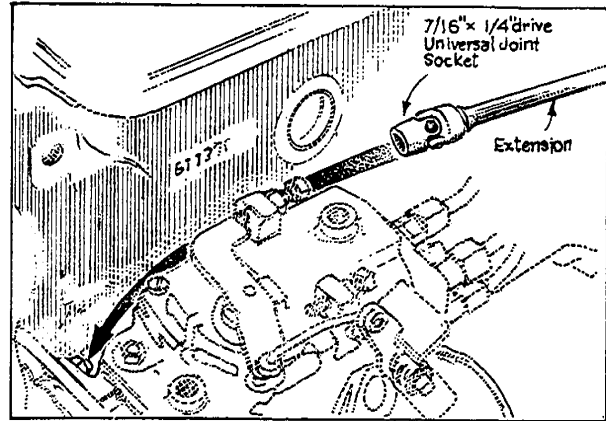
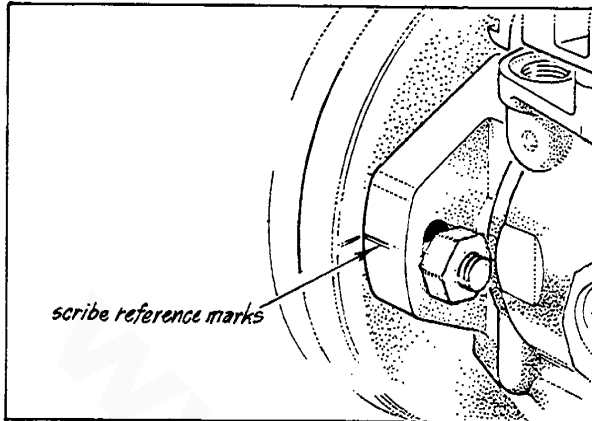

(d) Mount the injection pump on the gear case, then tighten the pump drive gear attaching nuts.

Tightening torque: 4.0 - 7.0 m-kg (29 - 51 ft-lb)

(e) Install the oil deflector on the crankshaft.

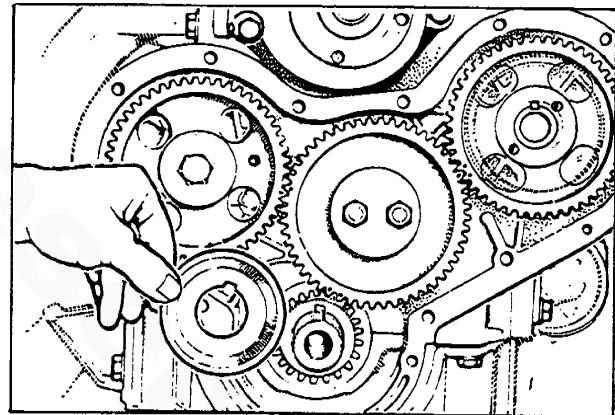

11. Install the timing gear cover.

(a) Install the bearing housing cover on the timing gear cover.

(b) Install the injection pump drive gear cover on the timing gear cover.

(c) Install the timing gear cover and tighten the timing gear cover attaching nuts and bolts after the crankshaft pulley has been installed temporarily to center the seal.

Timing gear cover tightening torque: 1.6-2.4 m-kg  
(11.6-17.4 ft-lb)

12. Install the crankshaft pulley, then temporarily tighten the pulley attaching bolt.

13. Mount the oil pump. Apply the sealing agent on set screw thread and tighten the screw.

14. Position the oil pan gasket set.  
(a) Position the gasket ends (A) on the gaskets (B) and (C).  
(b) Apply the sealing agent on mating surfaces of gasket and that between the cylinder block and the timing gear case.

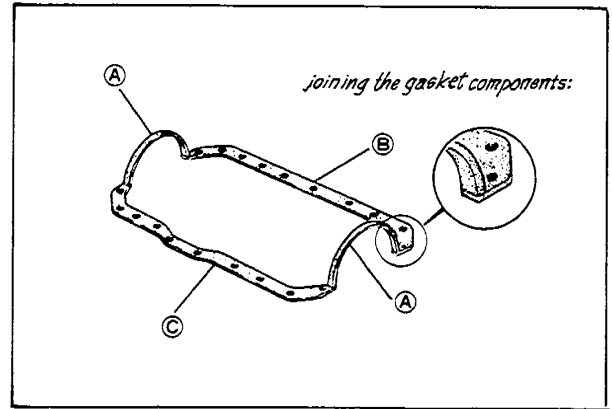

15. Install the oil pan.

Tightening torque: 1.60-2.30 m-k $g$  (12-17 ft-lb)

16. Attach the backing plate.

Tightening torque:

3.3-4.8 m-k $g$   
(23.9-34.7 ft-lb)

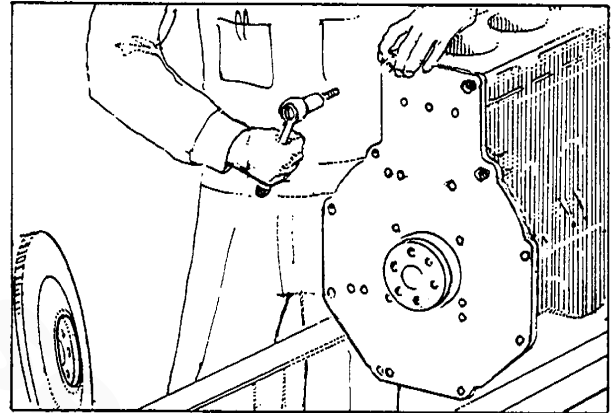

17. Install the flywheel.  
(a) Install the flywheel onto the rear end of the crankshaft.  
(b) Install the tabwasher plate (PN 31166) and the flywheel bolts and torque the bolts. Bend the tabwasher to lock the bolts in place.

Tightening torque: 80-85 ft-lb

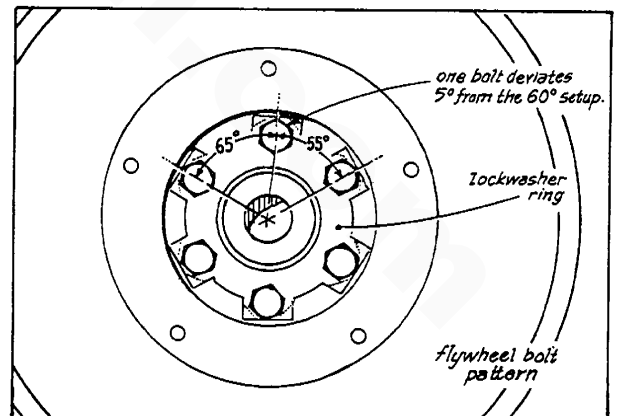

- (c) Tighten the front crankshaft pulley bolt.

Tightening torque: 35-40 m-k $g$  (253-289 ft-lb)

18. Install the two tubular dowels adjacent to cylinders 1 and 4 if they were removed earlier during disassembly. Position the gasket on cylinder block. Do not use any liquid seal or cement.
19. Position the cylinder head.
20. Insert the pushrod. Check if push rod is securely set in the tappet concavity.

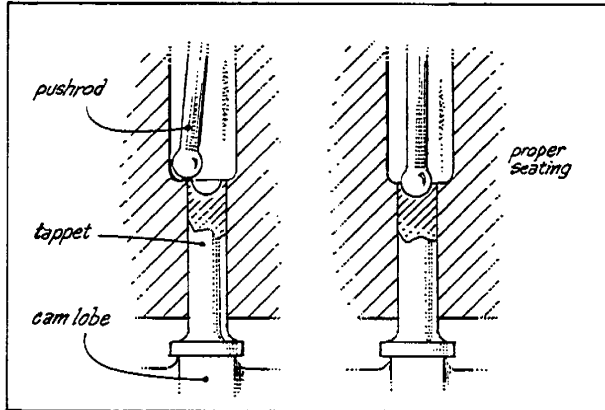
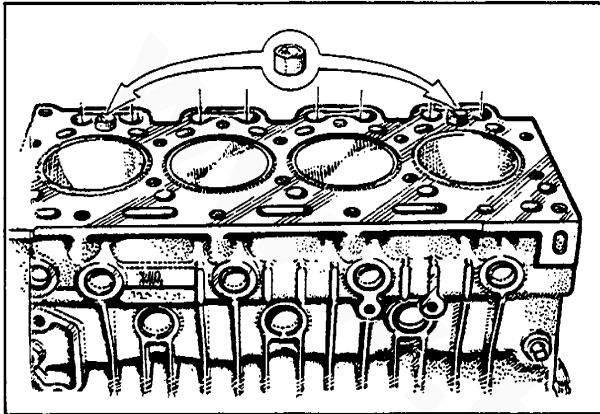

21. Position the valve cap on the top of valve stem.
22. Install the rocker arm assembly onto the cylinder head. Remember that the end of the rocker shaft having the pin occupying the slot in #1 rocker support points toward the front (fan pulley) end of the engine.

23. Tighten the cylinder head bolts. Tighten the cylinder head bolts evenly in the sequence shown in the figure.

Tightening torque:

11.8-12.5 m-kg  
(85-90 ft-lb)

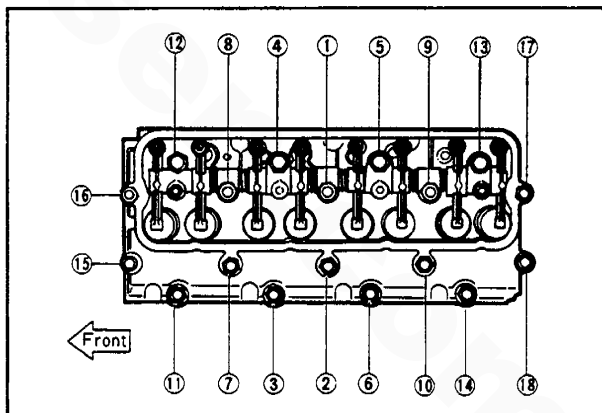

24. Adjust valve clearance.  
(a) Set the piston of No. 1 cylinder at TDC of compression stroke and adjust the valve clearances on 1, 2, 3 and 6 valves.  
(b) Set the piston of No. 4 cylinder at TDC of compression stroke and adjust valve clearances on 4, 5, 7 and 8.

Note: Valves are numbered 1 - 8 from front of engine.

Valve clearance (cold)  
Intake .30 mm (0.12 in)  
Exhaust .30 mm (0.12 in)

AFTER THE ENGINE HAS BEEN REASSEMBLED, WARM UP THE ENGINE AND READJUST THE VALVE CLEARANCES.

25. Install the thermostat and thermostat housing.  
26. Install the fresh water pump assembly.  
Tightening torque: 1.6-2.3 m-kG (12-17 ft-lb)

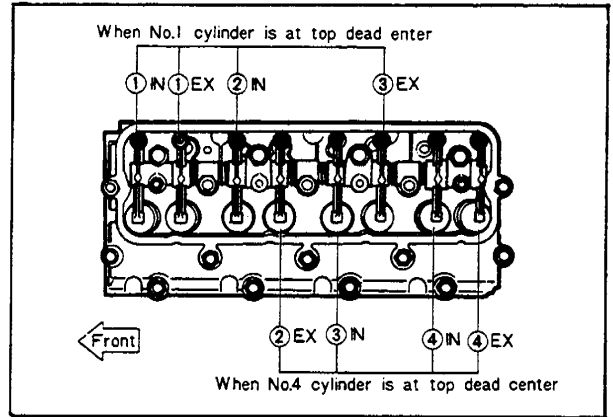

27. Adjust the injection timing.

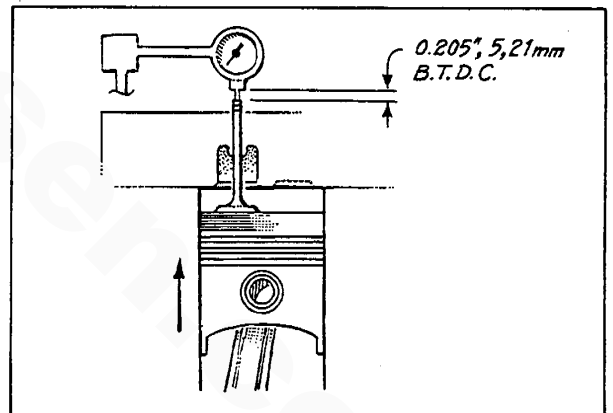

28. Mount the oil filter bracket and oil filter. Install new filter cartridge.  
29. Mount the front engine mounting bracket.  
Tightening torque: 4.6-6.8 m-kG (33-49 ft-lb)



30. Install the intake manifold.

Tightening torque:

1.6-2.4 m-kg  
(11.6-17.4 ft-lb)

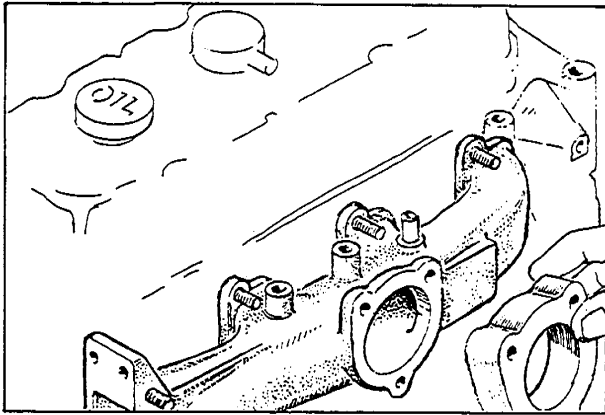

31. Mount the fuel filter assembly.

32. Install the fuel injection nozzles and fuel overflow pipe. Use new sealing washers throughout, in the same order as were the old washers.

Injection nozzle hold down nuts torque: 1.6-2.4 m-kg  
(11.6-17.4 ft-lb)

33. Install the glow plugs and connectors.

Glow plug tightening torque: 1.0-1.5 m-kg (7.2-10.8 ft-lb)

34. Mount the rocker arm cover and crankcase vent hose.

Rocker arm cover tightening torque: 0.25-0.40 m-kg  
(1.8-2.9 ft-lb)

35. Connect the fuel line to the engine mounted fuel filter and the line to the injection pump. (Use new sealing washers.)

36. Connect the high pressure injector lines from the injection pump to injectors. Reinstall line clamp.

Torque attaching nuts: 2.5-3.0 m-kg (18-22 ft-lb)

37. Install the bellhousing.

38. Install the air intake silencer.

39. Mount the engine heat exchanger and engine oil cooler on the flywheel bellhousing.

40. Install the alternator and drive belt. Insure the belt is in proper alignment with the fresh water circulating pump pulley and crankshaft pulley. Check tension.

41. Install the raw water pump and drive belt. Insure that it is in proper alignment with the crankshaft pulley. Check tension.

42. Install oil and water senders and switches. (See Figure for locations).

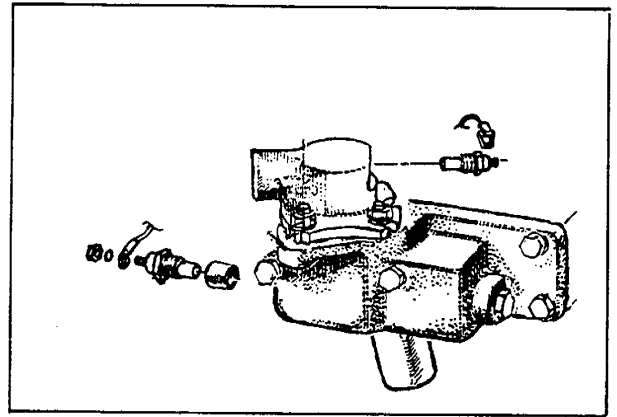

43. Install starter motor.
44. Install breaker panel and preheat solenoid.
45. Reinstall engine electrical harness.
46. Mount complete exhaust manifold/expansion tank to cylinder head.  
Torque mounting bolts: 2.7-3.3m-kg (20-24 ft-lb)
47. Install new hose connections and clamps for cooling system.
48. Reinstall the marine transmission and fill with proper lubricant.
49. Fill the engine cooling system with antifreeze mixture and the engine oil sump with lube oil (A.P.I. spec. CC or better).

The engine should be test run under load prior to reinstalling. At this time readjust the valve clearances on the hot engine.

FRESH WATER CIRCULATING PUMP

DISASSEMBLING

- (a) Remove the pump pulley boss by using a support and press.
- (b) Remove the bearing shaft from the impeller and bearing housing by using a support block and press.

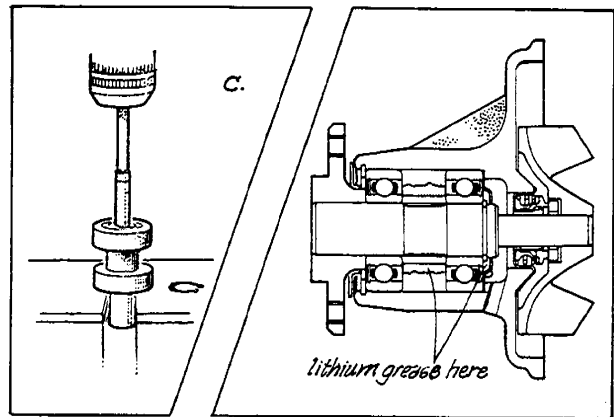
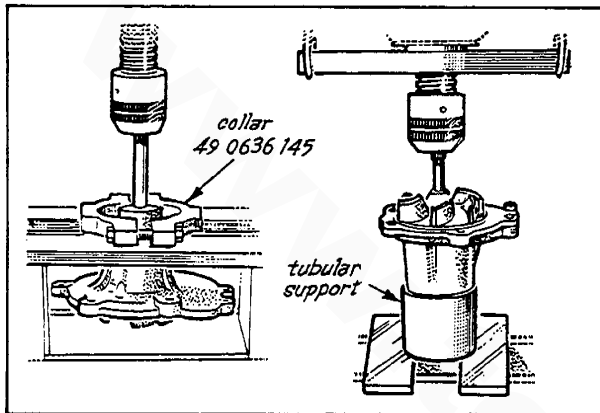

- (c) Remove the snap ring with snap ring pliers and press out the water pump shaft from the bearings.

ASSEMBLING

Assemble the water pump in the reverse order of disassembly, taking the following precautions:

- (a) Fill lithium grease (lithium base NLGI No. 2) into the following positions.
  - \*Ball bearings
  - \*Approx. 1/3 space between both ball bearings
  - \*Space between the ball bearing and water baffle plate

- (b) Apply thinly engine oil to press fit surface of water seal and press the larger end into the proper aperture of the pump using a tubular mandrel.

DO NOT ALLOW OIL OR GREASE TO CONTAMINATE THE SURFACES OF THE CERAMIC RING OR THE GRAPHITE (SMALL END) OF THE SPRING-LOADED SEAL.

- (c) After the water pump has been assembled, check if the pump shaft rotates smoothly.

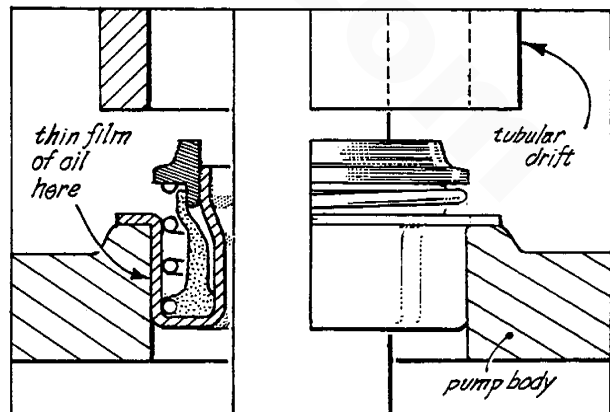

## FUEL INJECTION PUMP

For the disassembling, inspecting, reassembling and internal adjusting of the injection pump, it is recommended that the pump be given to a qualified injection service shop authorized to service Diesel KiKi injection equipment.

The only adjustment the servicing mechanic should make to the injection pump is the adjustment for engine idle speed.

### 1. Checking Idle Speed

- (a) Warm up the engine.
- (b) Remove any specks on the crankshaft pulley with a clean cloth and place a piece of suitable reflecting tape on the pulley to facilitate use of a photo-electric type tachometer.
- (c) Start and idle the engine.
- (d) Aim the light of the tachometer onto the reflecting tape to confirm the engine speed.
- (e) Adjust the idle speed if the engine speed is not within the specified value.

Normal idle speed: 600-700 RPM

2. To adjust engine idle speed, loosen the lock nut (3) of the idle adjustment bolt and turn the bolt clockwise to increase idle speed and counter-clockwise to reduce.

Note: Should engine RPM be in question, verify tachometer readings as shown at the instrument panel with a mechanical or strobe type tachometer at the engine crankshaft.

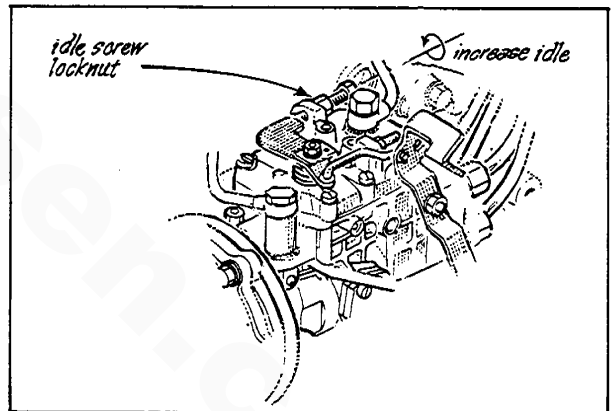

### 3. Inspecting and adjusting injection pump timing

- (a) Remove the air intake/silencer assembly.
- (b) Remove the 4 high pressure injector lines that connect between the injection pump and injectors.
- (c) Remove the bolt and gasket installed on the distributor head of the injection pump.
- (d) Remove the valve rocker cover.
- (e) Rotate the crankshaft in normal direction of rotation (use front crankshaft pulley nut) and place No. 1 piston at TDC of its compression stroke.

Note: To verify, the rocker arms of No. 4 cylinder should be rocking (one opening, the other closing).

- (f) Remove the snap ring circlip from the end of the rocker shaft at cylinder No. 1 along with the retaining washer.
- (g) Loosen the rocker arm adjusting bolt so as to allow the arm to be removed from the push rod and slide it off the rocker shaft.
- (h) Press down on the valve and spring assembly and note that the valve is hitting the top of No. 1 piston. Then remove the cap, keepers and valve springs from the No. 1 valve.

Note: Insure the valve moves freely in its guide. Take care not to drop keepers down push rod hole.

(i) Position a dial indicator gauge on the valve stem and with the front crankshaft pulley nut, rock the crankshaft counter-clockwise and clockwise to locate exact TDC of the compression stroke for No. 1 piston and then zero the dial indicator gauge to the valve stem. (The gauge should be able to measure up to .300 inch of valve movement.)

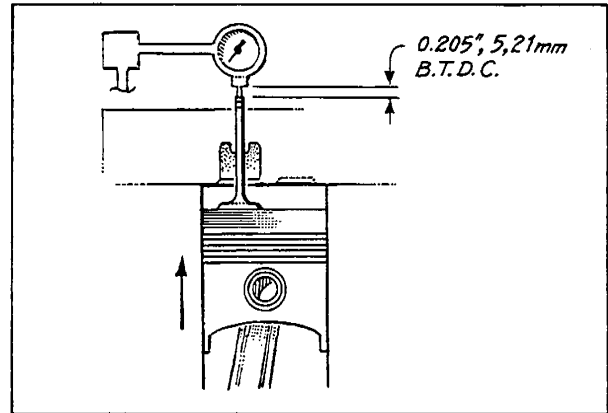

(j) Turn the crankshaft until the indicator shows the valve drop to be at .264 inch. This is 30 degrees BTDC.

(k) Install the measuring device (Diesel Kiki #57828-3520) in the bolt hole of the injection pump distributor head. (Refer to step c.) Insure that the feeler needle of the measuring device is in contact with the plunger inside of the pump. Zero the measuring device scale.

(l) Turn the crankshaft in the direction of normal rotation until the No. 1 piston is at TDC by referencing the indicator on the valve stem.

(m) The measuring device indicator needle should move 1.00 mm from the zero setting.

Beginning of static injection:  
Cam lift 1.00 mm (0.0394 in)

Note: If the measuring device shows movement at the plunger to be more or less than specified above, the injection pump must be adjusted to correct the movement.

## 5. Adjusting the injection pump

- (a) Disconnect the fuel supply and return line connections from the pump.
- (b) Disconnect the support bracket at the back of the injection pump as it attaches to the lube oil filter adapter.
- (c) Loosen the two injection pump hold down nuts that secure the injection pump to the engine.
- (d) Rotate the injection pump either towards the engine or away from the engine to adjust the measuring device indicator to show 1.0 mm of movement.
- (e) Secure the pump by tightening the two hold down nuts.

(f) Remove the measuring device and replace the bolt and gasket and reattach all fuel lines using new sealing washer.

6. Installing injection pump

Install the injection pump in the reverse order of removal, noting the following points:

(a) Tighten the lock nut of injection pump drive gear to the specified torque.

Tightening torque: 4.0-7.0m-kg (29-51 ft-lb)

(b) After the injection pump has been installed, loosen the overflow valve, and bleed the air by operating the priming pump.

## FUEL INJECTORS

1. Removing fuel injectors

(a) Disconnect the high pressure lines from the injectors and loosen the lines at their attachment to the injection pump and move them out of the way of the injectors. Avoid bending the lines.

(b) Remove the fuel return line in its entirety from the top of the injectors. Take care not to lose the two sealing washers and banjo bolt that attaches the fuel return line to each injector.

(c) Remove the two nuts and washers that hold the injector on the cylinder head.

(d) Lift the injector out of the cylinder head.

Note: Clean the area around the base of the injector prior to lifting it out of the cylinder head to help prevent any rust or debris from falling down into the injector hole. If the injector will not lift out easily and is held in by carbon build up or the like, work the injector side to side with the aid of an adjustable or open end wrench to free it and then lift it out.

(e) The injector seats in the cylinder head on a copper sealing washer. This washer should be removed with the injector and replaced with a new washer when the injector is reinstalled.

2. Injection testing

(a) The injector should be tested on an injector pipe tester for proper spray pattern and pressure setting.

Injection start pressure: 135-140 kg/cm<sup>2</sup>  
(1919.7-1990.8 lb/in<sup>2</sup>)

3. Inspecting and adjusting nozzle injection starting pressure

Using the nozzle tester, check the spray pattern and injection starting pressure of nozzle and, if it exceeds the limit, adjust or replace the nozzle.

When using nozzle tester, take the following precautions:

1. The spray injected from the nozzle is of such velocity that it may penetrate deeply into the skin of fingers and hands, destroying tissue.

If it enters the bloodstream, it may cause blood poisoning.

2. If the diesel fuel of the nozzle tester is stained, replace it. At the same time, clean or replace the filter.

3. Set the nozzle tester in a clean place where there is no dust or dirt.

(a) Mount the nozzle and nozzle holder on the nozzle tester.

(b) Operate the hand lever of nozzle tester several times to bleed the air in the nozzle line, then move the hand lever at intervals of one stroke per second while reading the injection starting pressure.

Start to injection: 135-140 kg/cm<sup>2</sup> (1920-1990 lb/in<sup>2</sup>)

(c) If the injection starting pressure of the nozzle is not within the limit, loosen the cap nut on the nozzle holder, insert flat screwdriver through the bolt hole of cap nut, then turn the pressure adjusting screw to set the injection starting pressure to 200 kg/cm<sup>2</sup> (2.844 lb/in<sup>2</sup>). Then, gradually decrease the pressure until the injection starting pressure is 135 kg/cm<sup>2</sup> (1920 lb/in<sup>2</sup>).

(d) After the injection starting pressure has been adjusted, hold the pressure adjusting screw with flat screwdriver, then tighten the cap nut. Then check the injection starting pressure again if it does not change.

3. Inspecting spray pattern

(a) Operate the hand lever of the nozzle tester at intervals of one stroke per second to check if the fuel is injected correctly in its axial direction.

A nozzle is defective if it injects fuel in an oblique direction or in several separate strips. Also, a spray in the form of particles indicates a defect. These defects may sometimes be caused by clogging with dust and, therefore, all parts should be carefully cleaned before reassembly. (Care should be taken not to expose one's skin to this spray as it may penetrate the skin and cause infection.)

(b) Apply the pressure of 115 kg/cm<sup>2</sup> (1635 lb/in<sup>2</sup>) to nozzle by operating the hand lever, and check the drips from the nozzle tip. If it drips or has a large accumulation of fuel on the bottom, it

is considered defective and should be replaced. A very small amount of fuel may sometimes remain on the tip of the nozzle; however, this does not indicate a defect.

(c) Operate the tester handle at intervals of 4-6 strokes per second while checking if it injects uniformly. If it does not, overhaul the nozzle or replace it.

4. Disassembling and inspecting

(a) Clamp the nozzle holder in a vise, then remove the cap nut.

(b) Remove the pressure adjusting screw, then pull out the upper seat, spring and the push rod.

(c) Clamp the nozzle holder in a vise, remove the nozzle nut then pull the nozzle out.

(d) Clean the disassembled parts with clean diesel fuel, then remove the carbon adhering on the nozzle.

Note: Do not use a metal tool to remove the carbon.

(e) After cleaning, check to see if the needle valve comes down into the valve seat by its own weight when setting the nozzle body upright position and inserting needle valve.

(f) Check that there is no flaw or other damage on mating surfaces and sliding surfaces of nozzle body and needle valve and, if present, replace the nozzle assembly.

5. Assembling

Assemble in the reverse order of disassembly, noting the following points:

(a) To assemble the nozzle and nozzle holder, first assemble the pressure adjusting nut side, and temporarily tighten the nut. Mount the nozzle and set the needle valve to proper position, then mount the nozzle nut.

(b) After the nozzle and nozzle holder have been assembled, check the injection starting pressure and spray condition.

Nozzle nut tightening torque: 8-10 m-kg (58-72 ft-lb)

Cap nut tightening torque: 4-5 m-kg (29-36 ft-lb)

6. Installing

Install the nozzle and nozzle holder assembly in the reverse order of removal, noting the following points:

(a) When installing the nozzle and nozzle holder assembly, use a new copper washer.

(b) Tighten the nozzle and nozzle holder assembly to the specified torque. Switch back and forth between the nuts; do not tighten one completely with the other loose.

Tightening torque: 1.6-2.4 m-kg (11.6-17.4 ft-lb)

## FUEL INJECTION NOZZLE

1. Removing injection nozzle

Remove in the following order:



- (a) Fuel injection lines.
  - (b) Fuel leak line attaching nuts.
  - (c) Fuel leak line (disconnect).
  - (d) Injection nozzles.
  - (e) Copper washers.
2. Removing nozzle holder  
Remove in the following order:
- (a) Fuel leak line.
  - (b) Injection lines (disconnect).
  - (c) Attaching nuts and nozzle holders.
  - (d) Gasket and dust seal.

3. Components of injection nozzle

1. Bolt
2. Gasket
3. Nut
4. Gasket
5. Screw
6. Nozzle spring upper seat
7. Spring
8. Push rod
9. Connector
10. Washer
11. Body
12. Nozzle
13. Nut

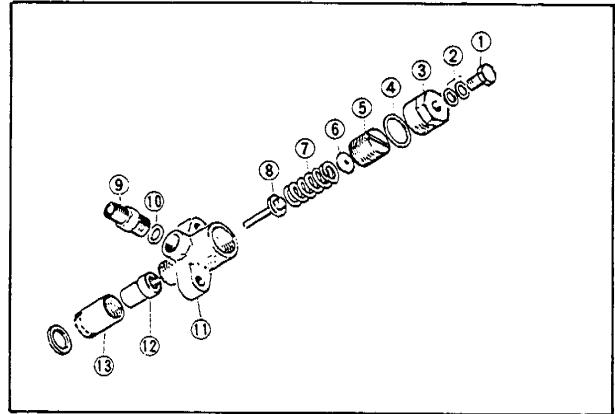

### INJECTOR TESTING

Test the injectors using diesel fuel at approximate temperature of 20°C (68°F).

1. Injection starting pressure
  - (a) Set the injector on the injector pop.
  - (b) Air-bleed by pumping the injector pop tester handle several times.
  - (c) Slowly lower the injector pop tester handle and check the value shown on the pressure gauge when injection is started.

Injection start pressure: 135-140 kg/cm<sup>2</sup>  
(1919.7-1990.8 lb/in<sup>2</sup>)

If the injection start pressure is not at the specified pressure, adjust it.

Loosen the cap nut on the injector holder and adjust by turning the pressure adjusting screw with a screwdriver.

- (a) Increase the injection starting pressure to about 200 kg/cm<sup>2</sup> (2844 lb/in<sup>2</sup>) once.
- (b) Gradually lower the injection starting pressure to the specified pressure.
- (c) When the injection starting pressure has been adjusted, keep the pressure adjusting screw stationary with a screwdriver passed through the cap nut bolt hole and tighten the cap nut to 4-5 m-kp

(8.82-11.02 lb).

(d) Check the injection starting pressure again.

2. Oil tightness of valve seat

Apply pressure 20 kg/cm<sup>2</sup> lower than the specified injection pressure, and see if the fuel leaks from the nozzle injection hole.

If the fuel leaks, it is necessary to disassemble, wash and recheck the injector nozzle or replace it.

3. Atomizing condition

(a) Set the nozzle on the nozzle tester.

(b) Air bleed by operating the nozzle tester handle several times.

(c) Keeping the pressure gauge of the nozzle tester in the non-functioning condition, quickly lower the handle (lower the handle as quickly as possible so that a pulsating whistling sound can be heard.) Repeat this operation several times and check the atomizing condition. Avoid the spray.

\*Make sure that the fuel is atomized uniformly and properly.

\*Make sure that the injection angle and direction are normal.

(d) If the atomizing condition is incorrect, it is necessary to disassemble, wash and recheck the nozzle or to replace it.

#### CHECKING INJECTOR NOZZLE

Assemble in the reverse order or disassembly.

Note: After assembling the nozzle holder, test it.

Tighten the nozzle nut and cap nut to the specified torque.

Specified torques:

Nozzle nut: 6-10 m-kg (43-72 ft-lb)

Cap nut: 4-5 m-kg (29-36 ft-lb)

#### FUEL FILTER

1. Replacing fuel filter

(a) Remove the fuel filter cartridge with suitable wrench.

(b) Apply some fuel to the O-ring on the new filter cartridge, then tighten the filter cartridge fully by hand. Do not use a wrench.

(c) Loosen the bleeder screw on filter body, then bleed the air by pushing the priming pump on top of the filter housing.

## YOUR NOTES

[www.torresen.com](http://www.torresen.com)

## OTHER OVERHAUL

CONTENTS	SECTION	PAGE
MARINE ENGINE ELECTRICAL SYSTEM.....	Q	
Activation by Keyswitch (1980 onwards).....		74
COOLING SYSTEM EXTERNAL.....	R	
TRANSMISSIONS.....	S	
Type HBW Short Profile Sailing Gear.....		84
Type BW Transmission.....		93
Warner Hydraulic.....		94
Paragon Hydraulic.....		99

## SECTION Q

### MARINE ENGINE ELECTRICAL SYSTEM

#### ACTIVATION BY KEYSWITCH

This system is supplied on most Westerbeke engines beginning May, 1980. Essentially, activation of the circuit is accomplished by the ignition position of the keyswitch. No oil pressure switch is required. The engine is preheated by turning the keyswitch to the ON position, then depressing the key. The engine is cranked by turning the keyswitch to the right-most momentary position.

Voltage is maintained to the instruments, fuel solenoid or fuel lift pump, if supplied, and to other electrical devices via the ON position of the keyswitch.

Models which have a fuel solenoid may be turned off via the keyswitch. Models with mechanical fuel lift pumps or no fuel solenoid are stopped by pulling a stop cable. Some models have a combined throttle/shut-off control.

The circuit is protected by a circuit breaker located on the engine. Any time excessive current flows, the circuit breaker will trip. This is a manual reset breaker which must be reset before the engine will operate electrically again.

**CAUTION:** The builder/owner must ensure that the instrument panel, wiring and engine are installed so that electrical devices cannot come in contact with sea water.

The latest information regarding your engine's electrical system is included on the wiring diagram shipped with the engine. Be sure to study this wiring diagram and all notes thereon.

SECTION Q

ACTIVATION BY KEYSWITCH

SCHMATIC DIAGRAM

WIRING DIAGRAM

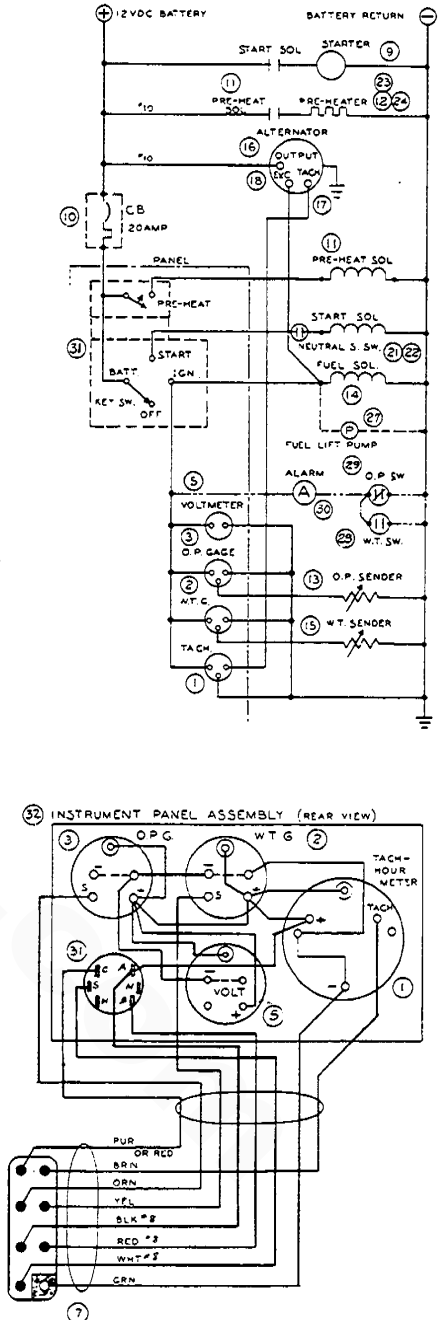
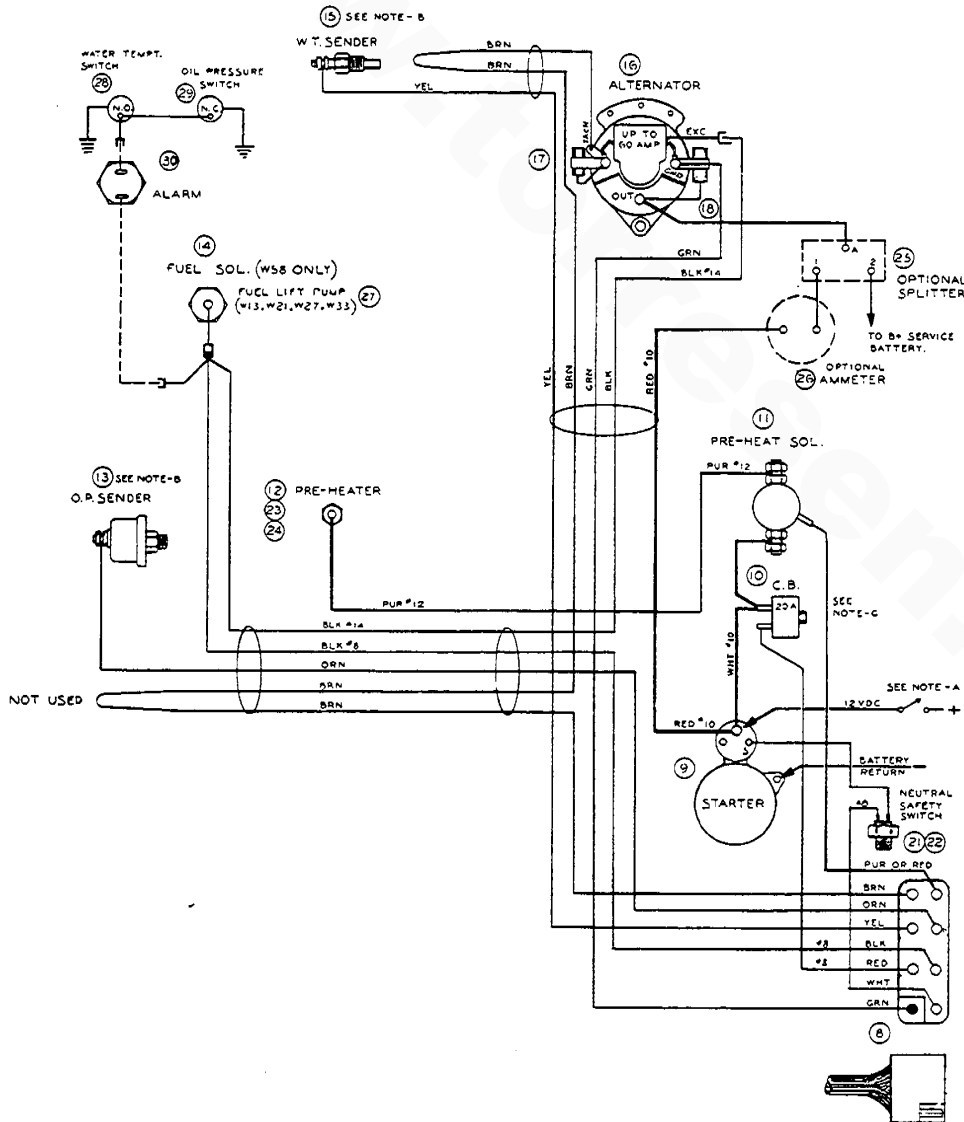

## YOUR NOTES

[www.torresen.com](http://www.torresen.com)

## SECTION R

### COOLING SYSTEM (EXTERNAL)

#### 1. DESCRIPTION

Westerbeke marine diesel engines are equipped with fresh water cooling. Transfer of heat from engine fresh water to sea water is accomplished by a heat exchanger, similar in function to an automotive radiator. Sea water flows through the tubes of the heat exchanger while fresh water flows around the tubes. The sea water and fresh water never mix with the result that the cooling water passages in the engine stay clean.

#### 2. FRESH WATER CIRCUIT

Heat rejected during combustion, as well as heat developed by friction, is absorbed by the fresh water whose flow is created by a fresh water circulating pump. The fresh water flows from the engine through a fresh water cooled exhaust manifold, a heat exchanger, in most cases an oil cooler, and returns to the suction side of the fresh water circulating pump. The flow is not necessarily in this order in every model. When starting a cold engine, most of the external flow to the heat exchanger is prevented by the closed thermostat. Some amount of by-pass is maintained to prevent overheating in the exhaust manifold. As the engine warms up, the thermostat begins to open up allowing full flow of engine fresh water through the external cooling system.

#### 3. SEA WATER CIRCUIT

The sea water flow is created by a positive displacement neoprene impeller pump (gear pump in certain special cases). Normally the pump draws sea water directly from the ocean via the sea cock and sea water strainer. Sometimes a transmission oil cooler, or perhaps a V-drive, will be piped on the suction side of the sea water pump. Generally, it is better to have as few devices on the suction side of the sea water pump as possible to preclude priming difficulties. Usually sea water flows directly from the discharge of the sea water pump to the heat exchanger sea water inlet. After passing through the tubes of the heat exchanger, the sea water may enter a transmission oil cooler, if present and if sea water cooled. Ultimately, the sea water enters a water injected, wet exhaust system, the most popular type of exhaust system in use. In the case of larger engines the sea water flow is divided prior to entering the exhaust systems so that a portion is used to cool the exhaust system. Full sea water flow would create unnecessary exhaust back pressure.

#### 4. SEA WATER PUMP

The sea water pump is self priming and positive displacement. It is a rotary pump with a non-ferrous housing and a neoprene impeller. The impeller has flexible vanes which wipe against a curved cam plate within the impeller housing, producing the pumping action. On no account should this pump be run dry. There should always be a spare impeller and impeller cover gasket aboard.



## 5. SEA WATER PUMP IMPELLER REPLACEMENT

The following instructions are general and indicative only. Specific instructions where applicable may be packaged with your replacement impeller.

- a. Remove the front cover gasket taking care to salvage the gasket.
- b. Remove the impeller by pulling straight outwards, parallel to the pump shaft. This is best done with a pair of pliers applied to the impeller hub.
- c. Coat the replacement impeller and the chamber into which it mounts with grease.
- d. Carefully align the impeller key way, or other locking mechanism, with the shaft. Take care that all the impeller blades bend in the same direction and trailing.
- e. Inspect the front cover for wear. A worn front cover should ultimately be replaced. Sometimes it can be reversed as an emergency measure, but not when stamped markings would break the seal between the cover and the impeller blades.
- f. Reinstall the end cover with a new gasket.
- g. Be doubly sure to check quickly for sea water flow when starting the engine. The absence of flow indicates that the pump may not be priming itself properly. This situation must be investigated immediately or damage to the new impeller will result from overheating.

## 6. ENGINE FRESH WATER

It is preferable to fill your engine with a 50% antifreeze-water mixture. This precludes the necessity of draining coolant in the winter. Since most antifreezes contain preservative agents of one kind or another, rusting within the engine is minimized. Also, the antifreeze mixture boils at a higher temperature than water, giving cooling system "head room".

When draining the engine, open the pressure cap first to relieve the vacuum created by draining.

## 7. FILLING THE FRESH WATER SYSTEM

It is very important to completely fill the fresh water system before starting the engine. It is normal for air to become trapped in various passages so all high points must be opened to atmosphere to bleed entrapped air. When an engine is started after filling with coolant, the system may look deceptively full until the thermostat opens. At this time when water flows through the external cooling circuit for the first time, pockets of air can be exposed and rise to the fill point. Be sure to add coolant at this time.

## 8. THERMOSTAT

Generally, thermostats are of two types. One is simply a choking device which opens and closes as the engine temperature rises and falls. The second type has a by-pass mechanism. Usually this is a disc on the bottom of the thermostat which moves downward to close off

an internal by-pass passage within the head. Both types of thermostats, from 1980 onwards, have a hole punched through them to serve as a by-pass while the engine is warming up. This prevents overheating in the exhaust manifold during engine warm-up. Replacement thermostats must be equal in this design characteristic.

When replacing a thermostat, be sure that it is rotated so as to not strike the thermostat housing, projections inside the head, temperature senders or temperature switches which may be installed close to the thermostat. Also insure the by-pass hole is not blocked by any part of the housing.

A thermostat can be checked for proper operation by placing it in a pan of cold water and then raising the temperature of the water to a boil. The thermostat should open noticeably (with travel on the order of 1/4" - 1/2") and be fully opened when the water is boiling.

#### 9. ENGINE LUBE OIL COOLER

Lubricating oil carries heat away from the engine bearings and other friction surfaces. The oil circulates from the lube oil pump, through the engine, through the engine oil cooler, and back to the oil pump.

The oil cooler may be cooled either by engine fresh water or by sea water.

#### 10. TRANSMISSION OIL COOLER

Certain transmissions require oil cooling. In these cases, the transmission oil cooler is usually cooled by sea water.

Normally, sea water enters this cooler after exiting the heat exchanger, but not always.

#### 11. EXHAUST MANIFOLD - EXTRUDED TYPE

##### REMOVAL

Removal of the exhaust manifold from the engine should be done as a complete assembly in the following manner.

- a. Drain the engine and cooling system of all coolant.
- b. Remove the exhaust connection.
- c. Loosen and remove all hose connections to the manifold.
- d. Loosen and remove the nuts or bolts attaching the manifold assembly to the cylinder head.
- e. Remove the manifold from the cylinder head as a complete unit.

##### SERVICING

- a. Remove the exhaust elbows from the lower surface of the manifold. Clean and inspect for cracks and defects. Replace as needed.
- b. Remove exhaust nipples, elbows and plugs from the manifold.
- c. Remove water connectors from the ends of the manifold and the end plates. Be sure to note the proper location and arrangement of each for proper replacement.
- d. Examine all parts for defects, corrosion and wear and replace as needed.

**REASSEMBLY**

- a. If the manifold was removed as an assembly and left intact, it can be replaced on the cylinder head in the reverse order of removal. Do not reuse the gaskets; install new ones and torque the bolts or nuts to the proper specification (10-12 lb-ft).
- b. If the manifold has been disassembled, follow the steps below.
  1. Loosely attach the elbows to the cylinder head and the manifold using new gaskets. Do not use any gasket sealant.
  2. Gradually tighten each fitting to make sure of proper alignment of all the parts. This should be done in three steps. Torque to 10-12 lb-ft.
  3. Reassemble the end plates, connectors on the manifold. Be sure to use new gaskets and coat the gasket surfaces with a suitable gasket cement such as "High Tack". Torque the nuts to 8-10 lb-ft.
  4. Reinstall the exhaust connections and plug into the manifold using "Locktite-Anti-Seize" on the threads.
  5. Reconnect all hoses, replacing them as needed.
  6. Refill the system with coolant as detailed above.
  7. Pressure test system and check for leaks.

**TWO PASS MANIFOLD**

Note: Drawing is indicative only. Specific models may vary in detail.

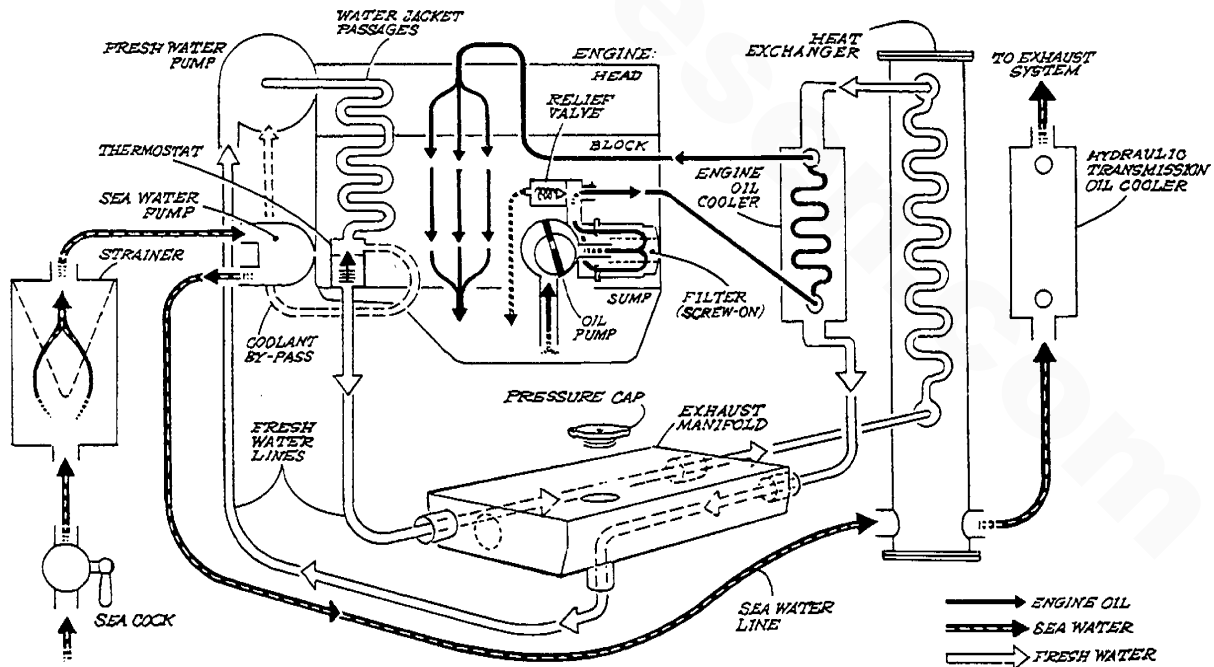

SINGLE PASS MANIFOLD

Note: Drawing is indicative only. Specific models may vary in detail.

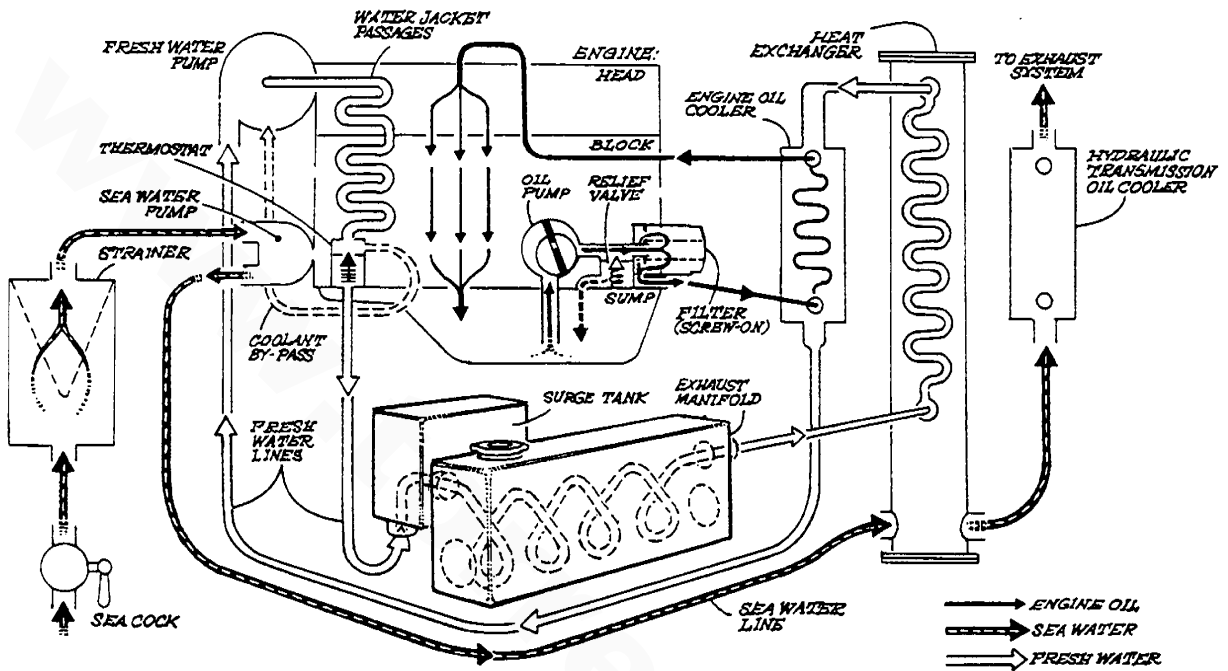

## **YOUR NOTES**

[www.torresen.com](http://www.torresen.com)

## **SECTION S**

### **TRANSMISSIONS**

## HBW SHORT PROFILE SAILING GEAR

### DESCRIPTION

#### 1. BRIEF DESCRIPTION

The Type HBW Short Profile Sailing Gears are equipped with a positively driven, mechanically operated helical gearing system. The servo-operated multiple-disc clutch requires only minimum effort for gear changing, making the transmission suitable for single-lever remote control via a rod linkage, Morse or Bowden cable.

The torque transmission capacity of the clutch is exactly rated, preventing shock loads from exceeding a predetermined value and thus ensuring maximum protection of the engine.

The transmission units are characterized by low weight and small overall dimensions. The gearbox castings are made of a high-strength, corrosion-resistant aluminum alloy, chromized for improved sea water resistance and optimum adhesion of paint.

The transmissions are immersion-lubricated. Maintenance is restricted to oil level checks (see "Maintenance").

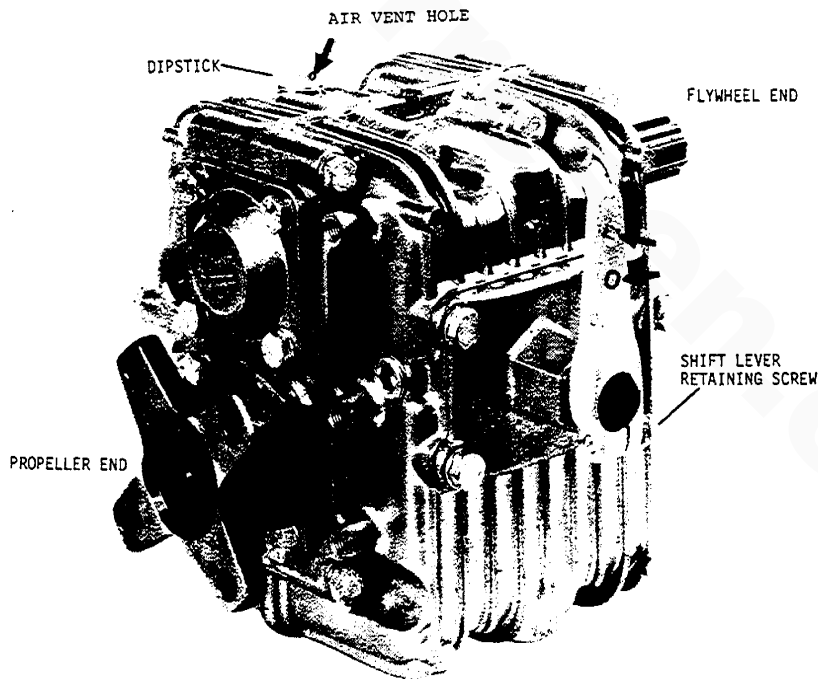

#### 2. GEAR CASING

The rotating parts of the HBW transmission are accommodated in an oil-tight casing divided into two halves in the plane of the vertical axis. Amply dimensioned cooling ribs ensure good heat dissipation and mechanical rigidity.

An oil filler screw with dipstick and an oil drain plug are screwed into the gear casing. The filler screw is provided with a breather hole.

The shaft for actuating the multiple-disc clutch extends through a cover on the side of the gear casing.

### 3. GEAR SETS

The transmission is equipped with shaved, casehardened helical gears made of forged low-carbon alloy steel. The multi-spline driving shaft connecting the transmission with the engine is hardened as well.

The driven shaft (propeller side) of the transmission is fitted with a forged coupling flange, except on the V-drive model.

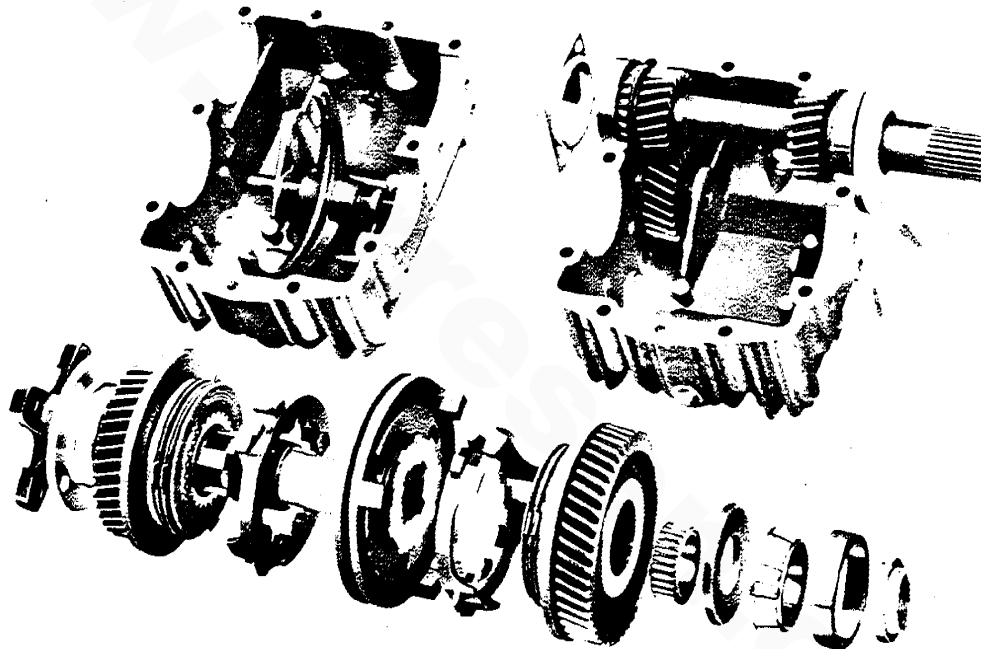

### 4. MULTIPLE-DISC CLUTCH INCLUDING OPERATION - POWER TRAIN

The engine torque is applied to the input shaft (36) in the specified direction of rotation and, IN SHIFTING POSITION A (forward), via gear (44), the frictionally engaged clutch discs (51 and 52) to the external disc carrier (57) and from there via the guide sleeve (59) to the output shaft (66).

IN SHIFTING POSITION B (reverse), the torque is transmitted from the input shaft (36) via intermediate gear (26), gear (65), clutch discs (51 and 52) to the external disc carrier (57), the guide sleeve (59) and the output shaft (66).



- FUNCTION

The transmission uses a positively driven, mechanically operated multiple-disc clutch system mounted on the output shaft.

The thrust force required for obtaining positive frictional engagement between the clutch discs is provided by a servo system. This essentially comprises a number of balls which, by the rotary movement of the external disc carrier, are urged against inclined surfaces provided in pockets between the guide sleeve and the external disc carrier and in this manner exert axial pressure. The thrust force and, as a result, the transmittable friction torque are thus proportional to the input torque applied. Due to the cup springs (48) supporting the clutch disc stack and a limitation of the range of axial travel of the external disc carrier (57), the thrust force cannot exceed a predetermined value.

The actuating sleeve (60) is held in the middle position by spring-loaded pins. To initiate the shifting operation, the actuating sleeve (60) need merely be displaced axially by a shifting fork until the arresting force has been overcome. Then the actuating sleeve (60) is moved automatically by the spring-loaded pins, while the external disc carrier, which follows this movement, is rotated by the frictional forces exerted by the clutch discs, and the shifting operation is completed as described above.

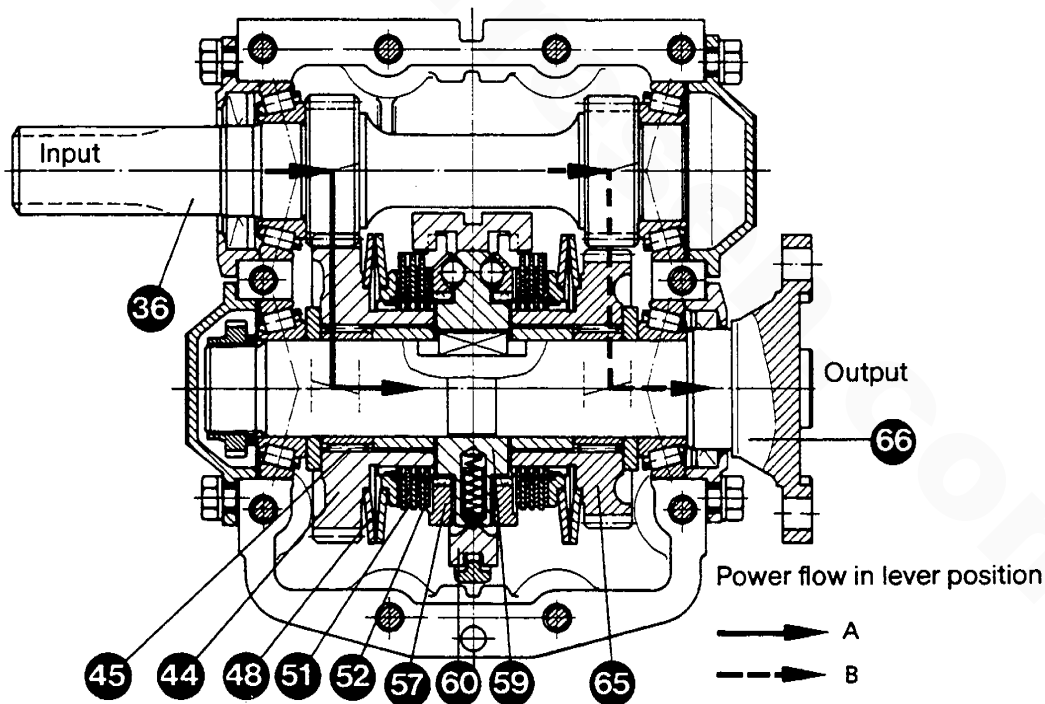

## 5. SHAFT BEARINGS

Both the input and the output shafts are carried in amply dimensioned taper roll bearings.

The intermediate gear and the movable gears are carried in sturdy needle roller bearings.

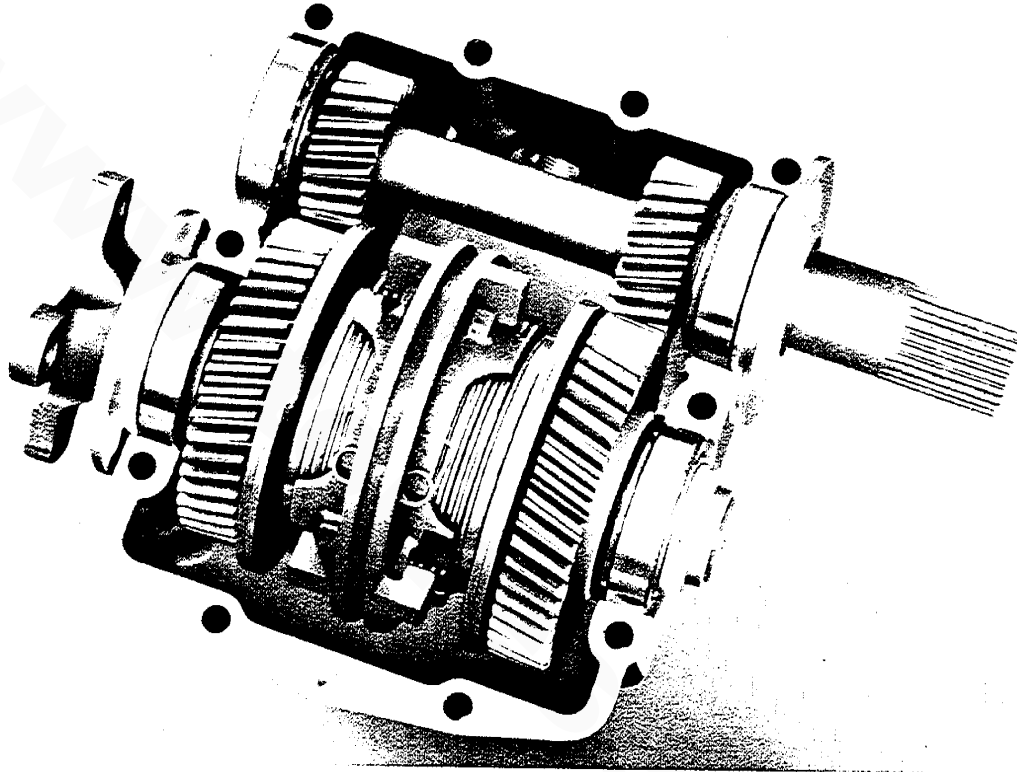

## 6. SHAFT SEALS

External sealing of the input and output shafts is provided by radial sealing rings. The running surface on the shafts is casehardened.

## 7. LUBRICATION

The transmissions are immersion-lubricated. The bearings are generously supplied with splash oil and oil mist.

## INSTALLATION

### 1. DELIVERY CONDITION

For safety reasons, the gearbox is NOT filled with oil for shipment. The actuating lever is mounted on the actuating shaft.

Before leaving the factory, each transmission is subjected to a test run with the prescribed ATF oil. The residual oil remaining in the

transmission after draining acts as a preservative and provides reliable protection against corrosion for at least 1 year if the units are properly stored.

## 2. PAINTING THE GEARBOX

ALWAYS COVER THE RUNNING SURFACES AND SEALING LIPS OF THE RADIAL SEALING RINGS ON BOTH SHAFTS BEFORE PAINTING. Make certain that the breather hole on the oil filler screw is not closed by the paint. Indicating plates should remain clearly legible.

## 3. CONNECTION OF GEARBOX WITH ENGINE

A torsio-elastic damping plate between the engine and the transmission is to compensate for minor alignment errors and to protect the input shaft from external forces and loads. Radial play should be at least 0.5 mm.

## 4. SUSPENSION OF ENGINE-GEARBOX ASSEMBLY IN THE BOAT

To protect the gearbox from detrimental stresses and loads, provision should be made for elastic suspension of the engine-gearbox assembly in the boat or craft.

The oil drain plug of the gearbox should be conveniently accessible.

## 5. POSITION OF GEARBOX IN THE BOAT

The inclination of the gearbox unit in the direction of the shafts should not permanently exceed an angle of 20 degrees (15 degrees for the V-drive model). (See illustration.)

The gearbox can also be mounted with the output shaft in the UPWARD position. Interchange the oil dipstick and the oil drain plug in this case.

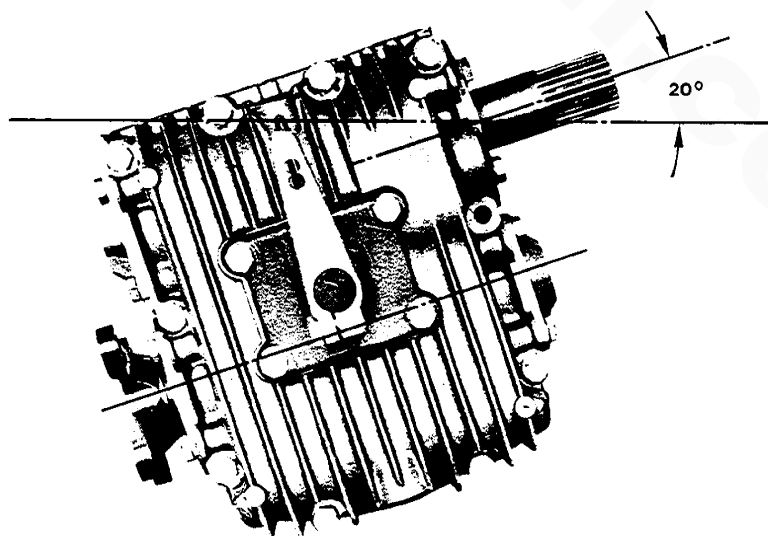

6. OPERATION OF GEARBOX

Gear changing requires only minimum effort. The gearbox is suitable for single lever remote control. Upon loosening the retaining screw, the actuating lever (see illustration) can be moved to any position required for the control elements (cable or rod linkage). Make certain that the lever does not contact the actuating lever cover plate (9): the minimum distance between lever and cover should be 0.5 mm.

The control cable or rod should be arranged at right angles to the actuating lever in the neutral position of the lever.

A larger amount of lever travel is in no way detrimental.

However, if the lever travel is shorter, proper gear engagement might be impeded which, in turn, would mean premature wear, excessive heat generation and resulting damage.

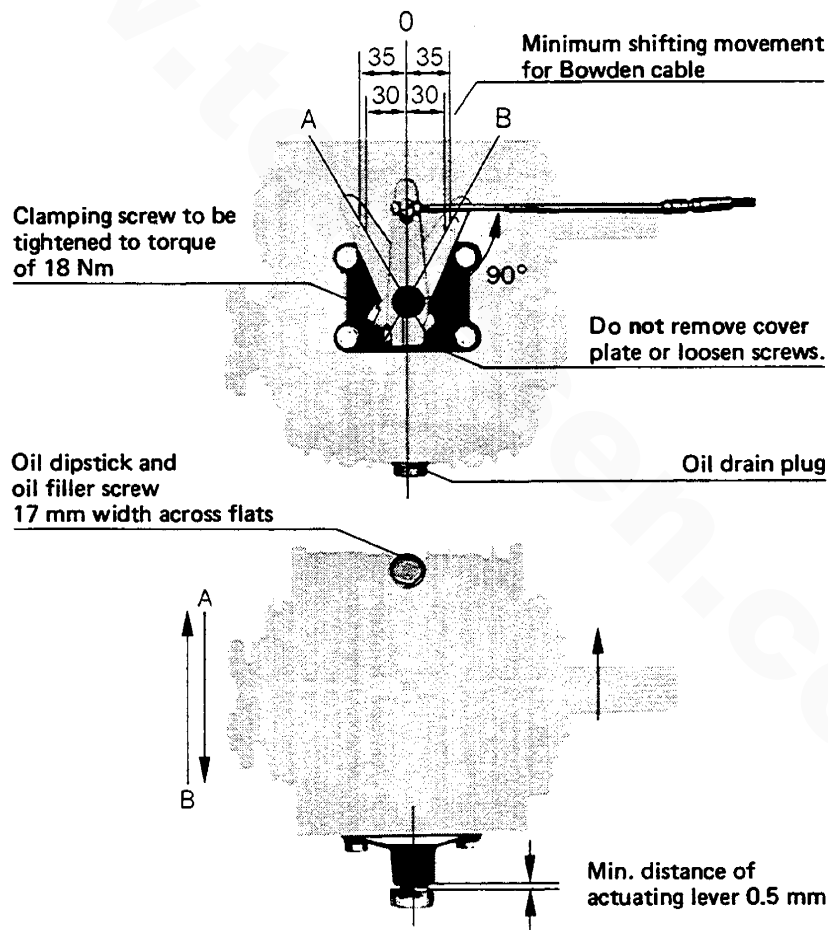

The position of the cover plate underneath the actuating lever is factory-adjusted to ensure equal lever travel from neutral position to A and B. Therefore, do not loosen the capscrews mounting this assembly.

When installing the gearbox, make certain that shifting is not impeded e.g. by restricted movability of the cable or rod linkage, by unsuitably positioned guide sheaves, too small bending radius, etc.

## 7. ENGINE-GEARBOX COMPARTMENT

Care should be taken that the engine-gearbox compartment is properly ventilated.

### OPERATION

#### 1. INITIAL OPERATION

Fill the gearbox with automatic transmission fluid. The oil level should be the index mark on the dipstick (see illustration).

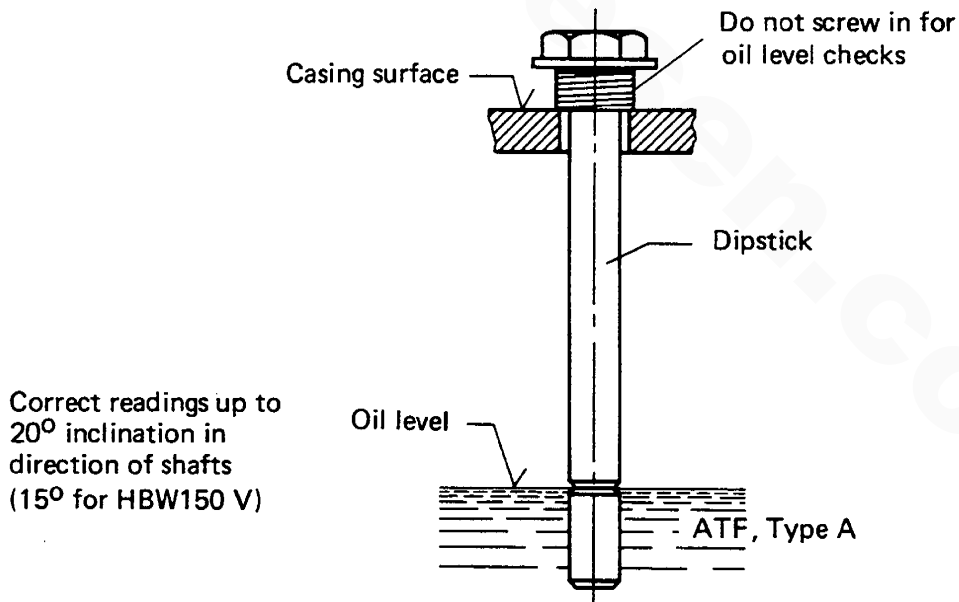

To check the oil level, just insert the dipstick; DO NOT SCREW IN. Retighten the hex screw with the dipstick after the oil level check. Do not omit the o-ring seal.

## 2. OPERATING TEMPERATURE

The maximum permissible temperature of the transmission oil is 130°C. If this temperature is to be exceeded, an optional oil cooler is available.

## 3. OPERATION OF GEARBOX

The zero position of the operating lever on the control console must coincide with the zero position of the actuating lever on the transmission. Shifting is initiated by a cable or rod linkage via the actuating lever and an actuating cam. The completion of the gear changing operation is servo-automatically controlled.

Gear changing should be smooth, not too slow, and continuous (without interruption). Direct changes from forward to reverse are permissible, since the multiple-disc clutch permits gear changing at high RPM, including sudden reversing at top speeds in the event of danger.

## 4. OPERATION WITHOUT LOAD

Rotation of the propeller without load, e.g. while the boat is sailing, being towed, or anchored in a river, as well as idling of the engine with the propeller stopped, will have no detrimental effects on the gearbox.

Locking of the propeller shaft by an additional brake is not required, since locking is possible by engaging the reverse gear. Do not sail while engaged in forward.

## 5. LAY-UP PERIODS

If the transmission is not used for periods of more than 1 year, it should be COMPLETELY filled with oil of the same grade to prevent corrosion. Protect the input shaft and the output flange by means of an anticorrosive coating if required.

## 6. PREPARATION FOR RE-USE

Drain the transmission of all oil and refill to the proper level with the prescribed oil.

## MAINTENANCE

### 1. TRANSMISSION OIL

To ensure trouble-free operation of the clutch, use only automatic transmission fluid (ATF).

Under no circumstances should the oil contain any additives such as molybdenum sulphite.

We recommend commercial Automatic Transmission Fluid (ATF), Type A or Dexron II.

## 2. OIL QUANTITY

HBW 5 approximately 0.4 liter  
HBW 10 approximately 0.6 liter  
HBW 20 approximately 0.8 liter  
HBW 50 approximately 0.3 liter  
HBW 100 approximately 0.35 liter  
HBW 150 approximately 0.55 liter  
HBW 150V approximately 1.0 liter  
HBW 220 approximately 0.75 liter  
Use the index mark on the dipstick as a reference.

## 3. OIL LEVEL CHECKS

Check the oil level in the transmission daily. Correct oil level is the index mark on the dipstick (see item 1 under OPERATION). Always use the same oil grade when topping up.

## 4. OIL CHANGE

Change the oil for the first time after about 25 hours of operation, then at intervals of at least once per year.

## 5. CHECKING THE CABLE OR ROD LINKAGE

The cable or rod linkage should be checked at shorter time intervals. Check the zero position of the operating lever (on the control console) and of the actuating lever (on the gearbox) on this occasion. The minimum lever travel from the neutral position to the operating positions ( $\overset{\wedge}{A} = 0-B$ ) should be 35 mm for the outer and 30 mm for the inner pivot point. Make certain that these minimum values are safely reached. Check the cable or rod linkage for easy movability (see item 6 under INSTALLATION).

## 6. OVERHAUL

Disassembly of the transmission in the field is not recommended. If an overhaul or repair is needed, the work should be done by Westerbeke or an authorized Westerbeke service center.

BW TRANSMISSIONS  
(BW3, BW7, BW12)

These manual transmissions rotate opposite to the engine when in forward gear. Shifting effort is very low. The input power on the BW3 is transmitted to the output shaft by helical spur gears when in forward. In reverse this task is taken over by a high performance roller chain. The unit also incorporates a servo cone-type clutch. The BW7 and BW12 transmit their power with casehardened helical gears and in reverse there is an intermediate gear. The reversing process on these is carried out by a servo double disc system.

LUBRICATION

1. Fill the transmission with 20 to 40 SAE weight engine oil, the same as is used in the engine.
2. Oil capacity  
BW3 approximately 0.35 liter  
BW7 approximately 1.0 liter  
BW12 approximately 1.0 liter
3. Check the oil level daily with the engine stopped. The level must be between the upper and lower dipstick marks when the dipstick is completely screwed/inserted into the housing.
4. Change the oil initially after the first 30 hours, thereafter every 250 hours, once per year minimum. The BW7 and BW12 have a drain plug for oil removal. Oil may also be removed by suction through the dipstick tube, where oil is added.
5. Operating oil temperature must not exceed 120°C (250°F).

OPERATION

1. Normal shifting should be done below 1500 RPM.
2. The BW3 may be locked in reverse when sailing or freewheeled in neutral.
3. The BW7 and BW12 may be locked in either forward or reverse when sailing or freewheeled in neutral.

SERVICE

1. Never loosen the shift lever cover screws, except in the course of qualified servicing, as this upsets a critical adjustment.
2. Disassembly of the transmission in the field is not recommended. If an overhaul or repair is needed, the work should be done by Westerbeke or an authorized Westerbeke service center.



## WARNER HYDRAULIC

### 1. DESCRIPTION

Westerbeke engines are also furnished with Warner hydraulic direct drive and reduction gear assemblies.

The direct drive transmission consists of a planetary gear set, a forward clutch, a reverse clutch, an oil pump and a pressure regulator and rotary control valve. All of these are contained in a cast iron housing along with necessary shafts and connectors, to provide forward, reverse and neutral operation. A direct drive ratio is used for all forward operation. In reverse, the speed of the output shaft is equal to the input shaft speed, but in the opposite direction. Helical gearing is used to provide quieter operation that can be obtained with spur gearing.

Oil pressure is provided by the crescent type pump, the drive gear of which is keyed to the drive shaft and operates at transmission input speed to provide screened oil to the pressure regulator.

From the regulator valve the oil is directed through the proper circuits to the bushings and anti-friction bearings requiring lubrication. A flow of lubricant is present at the required parts whenever the front pump is turning and, it should be noted that supply is positive in forward, neutral and reverse conditions.

The unit has seals to prevent the escape of oil.

Both the input and output shafts are coaxial, with the input shaft splined for the installation of a drive damper, and the output shaft provided with a flange for connecting to the propeller shaft.

### 2. CONTROL LEVER POSITION

The position of the control lever on transmission when in forward should be shifted to the point where it covers the letter "F" on the case casting, and is located in its proper position by the poppet ball. The Warranty is cancelled if the shift lever poppet spring and/or ball is permanently removed, or if the the control lever is changed in any manner, or repositioned, or if linkage between remote control and transmission shift lever does not have sufficient travel in both directions. This does not apply to transmissions equipped with Warner Gear electrical shift control.

### 3. LUBRICATION

The properties of the oil used in the transmission are extremely important to the proper function of the hydraulic system. Therefore, it is extremely important that the recommended oil, automatic transmission fluid (ATF), Type A be used.

NOTE: Be sure the cooler is properly installed and the transmission contains oil before cranking or starting the engine.

#### 4. CHECKING OIL LEVEL

The oil level should be maintained at the full mark on the dipstick. Check oil level prior to starting engine.

#### 5. FILLING AND CHECKING THE HYDRAULIC SYSTEM

Check daily before starting engine. The hydraulic circuit includes the transmission, oil cooler, cooler lines and any gauge lines connected to the circuit. The complete hydraulic circuit must be filled when filling the transmission and this requires purging the system of air before the oil level check can be made. The air will be purged from the system if the oil level is maintained above the pump suction opening while the engine is running at approximately 1500 RPM. The presence of air bubbles on the dipstick indicates that the system has not been purged of air.

New applications or a problem installation should be checked to insure that the oil does not drain back into the transmission from the cooler and cooler lines. Check the oil level for this drain back check only, immediately after the engine has been shut off and again after the engine has been stopped for more than one hour (overnight is excellent). A noticeable increase in the oil level after this waiting period indicates that the oil is draining from the cooler and cooler lines. The external plumbing should be changed to prevent any drain back.

#### 6. STARTING ENGINE

Place transmission selector in neutral before starting engine. Shifts from any selector position to any other selector position may be made at any time and in any order if the engine speed is below 1000 RPM; however, it is recommended that all shifts be made at the lowest feasible engine speed.

#### 7. NEUTRAL

Move the shift lever to the center position where the spring-loaded ball enters the chamfered hole in the side of the shift lever and properly locates lever in neutral position. With shift lever so positioned, flow of oil to clutches is blocked at the control valve. The clutches are exhausted by a portion of the valve and complete interruption of power transmission is insured.

#### 8. FORWARD

Move the shift lever to the extreme forward position where the spring-loaded ball enters the chamfered hole in the side of the shift lever and properly locates lever in forward position.

## 9. REVERSE

Move transmission shift lever to the extreme rearward position where the spring-loaded ball enters the chamfered hole in the side of the shift lever and properly locates it in the reverse position.

## 10. FREEWHEELING

Under sail with the propeller turning, or at trolling speeds with one of two engines shut down, the design of the gear maintains adequate cooling and lubrication.

## 11. COOLING PROBLEMS

Water passages inside of the cooler will sometimes become clogged, and this will reduce cooling capacity and cause overpressuring. Back flushing of the cooler will sometimes help to flush the foreign material from the cooler passages. The cooler and hose should be thoroughly flushed or replaced in the event a failure has occurred. Metallic particles from the failure tend to collect in the case of the cooler and gradually flow back into the lube system. Replace oil cooler to prevent contamination of the new transmission.

Water hoses may collapse and reduce or completely shut off all flow to the cooler. Collapsed hoses are usually caused by aging of the hoses or improper hose installation. Hose installation should be made with no sharp bends. Hoses should be routed so there is no possibility for engine shifting to cause hoses to pull loose or become pinched. A visual inspection of hoses while under way will sometimes allow detection of faulty hoses.

Reduction or complete loss of water flow can be caused by a faulty water pump. A rubber water pump impeller will sometimes fail and after such a failure the cooler passages may be restricted by the particles of rubber from the failed impeller. Water pump cavitation may be caused by improper or faulty plumbing or an air leak on the inlet side of the pump. The water pump may not prime itself or may lose its prime when inlet plumbing is not properly installed.

It is possible for cross leaks to occur inside the cooler, permitting oil to flow into the water or water flow into the oil.

## ROUTINE CHECKS AND MAINTENANCE

### ANNUAL CHECKS

1. PROPELLER AND OUTPUT SHAFT ALIGNMENT: This check should also be made anytime the propeller strikes a heavy object and after any accident where the boat is stopped suddenly. Shaft alignment should also be checked after the boat has been lifted by a hoist or moved on a trailer.
2. SHIFT LEVER POSITIONING: The selector controls must position the shift lever exactly in F, N and R selection positions with the ball poppet centered in the shift lever hole for each position.
3. BOLT TORQUE: Check all bolts for tightness.
4. COOLER CONNECTIONS: Check water lines, oil lines and connections for leakage. Make sure lines are securely fastened to prevent shifting.
5. CHANGING OIL: A seasonal oil change is recommended in pleasure boats. Work boats require more frequent changes. Change oil anytime the oil becomes contaminated, changes color or becomes rancid smelling.
6. TRANSMISSION FLUID: Automatic transmission fluids are recommended for use in all transmissions.

### DAILY CHECKS

1. Check transmission oil level.
2. Check for any signs of oil leakage in the bellhousing, at gasket sealing surfaces or at the output shaft oil seal.
3. A quick visual check of the general condition of the equipment may cause faulty equipment to be detected.
4. Listen for any unusual noises and investigate to determine the cause of any such noises.

### WINTER STORAGE

1. Drain water from transmission oil cooler. This will prevent freezing in cooler climates, and prevent harmful deposits from collecting.

### GENERAL CHECKS

1. Check coupling alignment each time a transmission is replaced in the boat.

2. Check shift linkage adjustment to insure that the transmission shift lever is positioned so that the spring loaded ball enters the chamfered hole in the side of the shift lever.
3. Connect an oil cooler into the cooler circuit before cranking or starting the engine. Various cooler circuits have been used and the correct cooler connections should be found from service literature prior to making the cooler installation.
4. Use a cooler of sufficient size to insure proper cooling.
5. Check engine rotation and transmission pump setting and the propeller rotation prior to assembling the transmission to engine.
6. Check oil pressure and temperature when transmission function indicates that a problem exists.
7. Use the recommended fluid for filling the transmission.
8. Fill the transmission prior to starting the engine.
9. Check oil level immediately after the engine has been shut off.
10. Use a clean container for handling transmission fluid.
11. Replace cooler line after a transmission failure, prior to installing a new or rebuilt transmission.
12. Check fluid level at operating temperature.

PARAGON HYDRAULIC

1. INSTALLATION

The installation instructions below are for use when the original transmission has been removed for servicing and must be reinstalled, or when the transmission unit is to be adapted as non-original equipment to a marine engine.

It is important that the engine and transmission rotations are matched. The direction of rotation of an engine is defined in this manual as the direction of rotation of the engine crankshaft as viewed from the output end of the transmission. A clockwise rotation of the engine is a right hand rotation and a counter-clockwise rotation of the engine is a left hand rotation.

A letter "R" or "L" appearing on the transmission serial number plate indicates whether the transmission is for use with a right or left hand rotating engine.

The hydraulic transmission is attached to the engine in the following manner:

- A. Insert two 3-1/2" studs in opposite transmission mounting holes in the flywheel housing.
- B. Place the transmission against the studs so that the studs go through two of the matching holes in the transmission housing flange.
- C. Slide the transmission along the studs toward the engine so that the spline on the shaft at the front of the transmission enters the matching splined hole in the engine vibration dampener.
- D. Install and tighten four bolts with lockwashers through the transmission housing flange into the flywheel housing. Remove the 3-1/2" studs. Install and tighten the two remaining bolts with lockwashers through the transmission housing flange.

The transmission and propeller shaft coupling must be carefully aligned before the propeller shaft is connected to the transmission, in order to avoid vibration and consequent damage to the transmission, engine and boat hull during operation. To align the coupling, move the propeller shaft, with attached coupling flange, toward the transmission so that the faces of the propeller shaft coupling flange and transmission shaft coupling flange are in contact. The coupling flange faces should be in contact throughout their entire circumference. The total runout or gap between the faces should not exceed .002" at any point. If the runout exceeds .002", reposition the engine and attached transmission by loosening the engine support bolts and adding or removing shims to raise or lower either end of the engine. If necessary, move the engine sideways to adjust the runout or to align the coupling flange faces laterally. Tighten the engine

support bolts and recheck the alignment of the coupling before bolting the coupling flanges together. Connect the coupling flanges with bolts, lockwashers and nuts.

Connect the oil cooler lines to the transmission.

Connect the shift control cable from the cockpit control station to the transmission control valve lever. Place the transmission control valve lever in the neutral position and adjust the shaft control cable length until the cockpit control station hand lever is in the neutral position. Move the cockpit control hand lever to forward and reverse positions several times while observing the transmission control valve lever motion. The transmission control valve lever should move fully into forward or reverse position when the hand lever is moved into forward or reverse position, and should return exactly to the neutral position when the hand lever is in the neutral position.

Remove the oil dipstick and fill the transmission with Type A transmission fluid to the mark on the dipstick. Replace the dipstick in the transmission housing.

## 2. OPERATION

**PRINCIPLE OF OPERATION:** The transmission forward and reverse drives are operated by transmission oil under pressure. An internal gear type oil pump delivers the transmission oil, under pressure to the external oil cooler. The transmission oil is returned, still under pressure, to the oil distribution tube and relief valve. The relief valve maintains the oil pressure by remaining closed until the oil pressure reaches 60 PSI. When the control lever is shifted to the forward position, oil under pressure is delivered to the multiple disc clutch piston, which moves to clamp the clutch discs and planetary reverse gear case together. The discs and case then revolve as a solid coupling in the direction of engine rotation. The reverse drive is engaged by shifting the control lever to the reverse position, so that oil under pressure is delivered to the reverse piston. The reverse piston moves to clamp the reverse band around the planetary gear case, preventing the planetary gear case from moving but allowing the planetary gears to revolve to drive the output or propeller shaft in a direction opposite to the rotation of the engine. With the control lever in the neutral position, pressurized oil is prevented from entering the clutch piston or reverse band piston and the propeller shaft remains stationary.

### STARTING PROCEDURE:

- A. Always start the engine with the transmission in NEUTRAL to avoid moving the boat suddenly forward or back.
- B. When the engine is first started, allow it to idle for a few moments. Stop the engine and check the transmission oil level. Add oil if necessary to bring the oil level up to the mark on the transmission dipstick.

**NOTE:** ON SUBSEQUENT START-UPS, THE TRANSMISSION OIL LEVEL MAY BE CHECKED BEFORE RUNNING THE ENGINE, WHEN ENGINE OIL IS CHECKED.

- C. Start the engine again, with the transmission in NEUTRAL, and allow the engine to warm up to operating temperature.
- D. Shift the transmission into FORWARD or REVERSE as desired. If the engine should stall when the transmission is shifted to FORWARD or REVERSE, place the transmission in neutral before restarting the engine.

It is recommended that shifting be done at speeds below 1000 RPM, and preferable in the 800 RPM or idle engine range, to prolong the life of the engine, transmission and boat. EMERGENCY shifts may be made at higher engine speeds, but this is not a recommended practice.

### 3. MAINTENANCE

**LUBRICATION:** The transmissions are self-contained units, independent of the engine lubricating systems. The units are lubricated by pressure and by splash from its own oil. The type of oil recommended is "Transmission Fluid, Type A", commonly used for automatic transmissions in automobiles.

The quantity of oil depends upon the angle of installation as well as the reduction model. The level must be maintained at the mark on the dipstick and should be checked periodically to ensure satisfactory operation.

When filling for the first time or refilling after an oil change, check the level after running for a few minutes to make certain that the oil cooler and the various passages are full. If necessary, refill to the mark on the dipstick to ensure proper operation of the transmission. The transmission oil level should be checked each time the engine oil level is checked, before running the engine.

The oil in the transmission should be changed every 100 hours, or each season under normal conditions. However, the number of hours that can be run between oil changes varies with the operating conditions. Drain plugs are located at the bottom of the reverse gear housing and the reduction gear housing.

**ADJUSTMENTS:** No adjustment is necessary for the FORWARD drive multiple disc clutches, and the reverse band is self-adjusting to compensate for lining wear, so that no external reverse band adjustment is necessary.



Trouble Shooting Chart

PROBLEM	POSSIBLE CAUSES AND METHODS OF CORRECTION
<p><b>GEAR INOPERATIVE</b></p> <p>Drive Shaft does not operate with selector valve in forward or reverse.</p>	<ol style="list-style-type: none"> <li>1. Low Oil Pressure.                             <ol style="list-style-type: none"> <li>a. Low oil supply. Add oil, refer to lubrication.</li> <li>b. Faulty oil gauge. Replace gauge. Oil gauge slow to register, air or obstruction in oil gauge line. Clean and bleed oil gauge line.</li> <li>c. Plugged oil lines or passages. Clean lines or passages.</li> <li>d. Oil pressure relief valve scored and sticking. Remove relief valve. Clean valve and valve bore in control valve housing with crocus cloth to free valve, or replace.</li> <li>e. Defective pistons and oil distributor seal rings. Replace seal rings.</li> <li>f. Defective oil pump. Check for wear and replace if necessary.</li> </ol> </li> <li>2. High Oil Temperature                             <ol style="list-style-type: none"> <li>a. Low oil supply. Add oil, refer to lubrication.</li> <li>b. Low water level in cooling system. Add water, and check for leaks.</li> <li>c. Plugged raw water inlet screen. Clean screen.</li> <li>d. Collapsed or disintegrated water inlet hose. Replace hose.</li> <li>e. Air leak in cooling water suction line. Replace suction line.</li> <li>f. Raw water pump impeller worn or damaged. Replace impeller.</li> <li>g. Clogged or dirty oil cooler element. Remove and clean</li> </ol> </li> <li>3. Reverse Band not engaging Planetary Gear Cage.                             <ol style="list-style-type: none"> <li>a. Reverse band lining worn out. Replace lining.</li> <li>b. Defective reverse piston "O" ring. Replace "O" ring.</li> </ol> </li> <li>4. Failure of Planetary Assembly.                             <p>Remove gear case assembly, and check for defective or damaged parts. Replace defective or damaged parts.</p> </li> <li>5. Failure of Reduction Gear.                             <p>Remove reduction gear assembly and check for defective or damaged parts. Replace defective or damaged parts.</p> </li> </ol>

PROBLEM	POSSIBLE CAUSES AND METHODS OF CORRECTION								
<p><b>GEAR DRAGGING</b></p> <p>Drive Shaft rotates either forward or reverse with Selector Valve in neutral position.</p>	<table border="0"> <tr> <td style="vertical-align: top;">1. Defective forward Clutch Plates.</td> <td>Forward clutch plates warped and sticking. Remove clutch plates and replace.</td> </tr> <tr> <td style="vertical-align: top;">2. Defective forward Clutch Piston Release Spring.</td> <td>Forward clutch piston release spring broken or weak. Replace spring.</td> </tr> <tr> <td style="vertical-align: top;">3. Binding in Planetary Assembly.</td> <td>                     a. Bearings and gears worn excessively in gear case. Replace necessary parts.                       b. Input shaft bearings worn excessively, causing misalignment of input shaft. Replace necessary parts.                 </td> </tr> </table>	1. Defective forward Clutch Plates.	Forward clutch plates warped and sticking. Remove clutch plates and replace.	2. Defective forward Clutch Piston Release Spring.	Forward clutch piston release spring broken or weak. Replace spring.	3. Binding in Planetary Assembly.	a. Bearings and gears worn excessively in gear case. Replace necessary parts.  b. Input shaft bearings worn excessively, causing misalignment of input shaft. Replace necessary parts.		
1. Defective forward Clutch Plates.	Forward clutch plates warped and sticking. Remove clutch plates and replace.								
2. Defective forward Clutch Piston Release Spring.	Forward clutch piston release spring broken or weak. Replace spring.								
3. Binding in Planetary Assembly.	a. Bearings and gears worn excessively in gear case. Replace necessary parts.  b. Input shaft bearings worn excessively, causing misalignment of input shaft. Replace necessary parts.								
<p><b>GEAR SLIPPING OR SLOW TO ENGAGE</b></p> <p>With Selector Valve in forward or reverse position.</p>	<table border="0"> <tr> <td style="vertical-align: top;">1. Low Oil Pressure.</td> <td>See "Gear Inoperative," (1).</td> </tr> <tr> <td style="vertical-align: top;">2. Worn forward Clutch Plates.</td> <td>Remove forward clutch plates and check for wear excessively, replace clutch plates.</td> </tr> <tr> <td style="vertical-align: top;">3. Reverse Band not engaging Gear Case.</td> <td>See "Gear Inoperative", (3).</td> </tr> </table>	1. Low Oil Pressure.	See "Gear Inoperative," (1).	2. Worn forward Clutch Plates.	Remove forward clutch plates and check for wear excessively, replace clutch plates.	3. Reverse Band not engaging Gear Case.	See "Gear Inoperative", (3).		
1. Low Oil Pressure.	See "Gear Inoperative," (1).								
2. Worn forward Clutch Plates.	Remove forward clutch plates and check for wear excessively, replace clutch plates.								
3. Reverse Band not engaging Gear Case.	See "Gear Inoperative", (3).								
<p><b>INTERNAL AND EXTERNAL LEAKS</b></p>	<table border="0"> <tr> <td style="vertical-align: top;">1. Water in Lubricating Oil.</td> <td>                     a. Hole in oil cooler element permitting water to seep into oil compartment. Replace oil cooler element.                       b. Oil cooler gaskets. Check gaskets and replace.                 </td> </tr> <tr> <td style="vertical-align: top;">2. Excessive Oil in Engine Crankcase or Flywheel Housing.</td> <td>Defective front end plate oil seal. Replace oil seal.</td> </tr> <tr> <td style="vertical-align: top;">3. Oil on Exterior of Marine Gear.</td> <td>                     a. Oil seeping from breather. Check for too high oil level.                       b. Defective rear end oil seal. Replace oil seal.                 </td> </tr> <tr> <td style="vertical-align: top;">4. Loss of Oil from Transmission.</td> <td>a. Check for defective gaskets and seal.</td> </tr> </table>	1. Water in Lubricating Oil.	a. Hole in oil cooler element permitting water to seep into oil compartment. Replace oil cooler element.  b. Oil cooler gaskets. Check gaskets and replace.	2. Excessive Oil in Engine Crankcase or Flywheel Housing.	Defective front end plate oil seal. Replace oil seal.	3. Oil on Exterior of Marine Gear.	a. Oil seeping from breather. Check for too high oil level.  b. Defective rear end oil seal. Replace oil seal.	4. Loss of Oil from Transmission.	a. Check for defective gaskets and seal.
1. Water in Lubricating Oil.	a. Hole in oil cooler element permitting water to seep into oil compartment. Replace oil cooler element.  b. Oil cooler gaskets. Check gaskets and replace.								
2. Excessive Oil in Engine Crankcase or Flywheel Housing.	Defective front end plate oil seal. Replace oil seal.								
3. Oil on Exterior of Marine Gear.	a. Oil seeping from breather. Check for too high oil level.  b. Defective rear end oil seal. Replace oil seal.								
4. Loss of Oil from Transmission.	a. Check for defective gaskets and seal.								

## **YOUR NOTES**

[www.torresen.com](http://www.torresen.com)

## **GENERATOR SETS**

CONTENTS	PAGE
Controls:	
Manual Starter Disconnect (Toggle Switches).....	106
Generator - 15 - 20KW - from September 1981.....	112
Generator - 15 - 20KW - YD Series to September 1981.....	123

MANUAL STARTER DISCONNECT (TOGGLE SWITCHES)

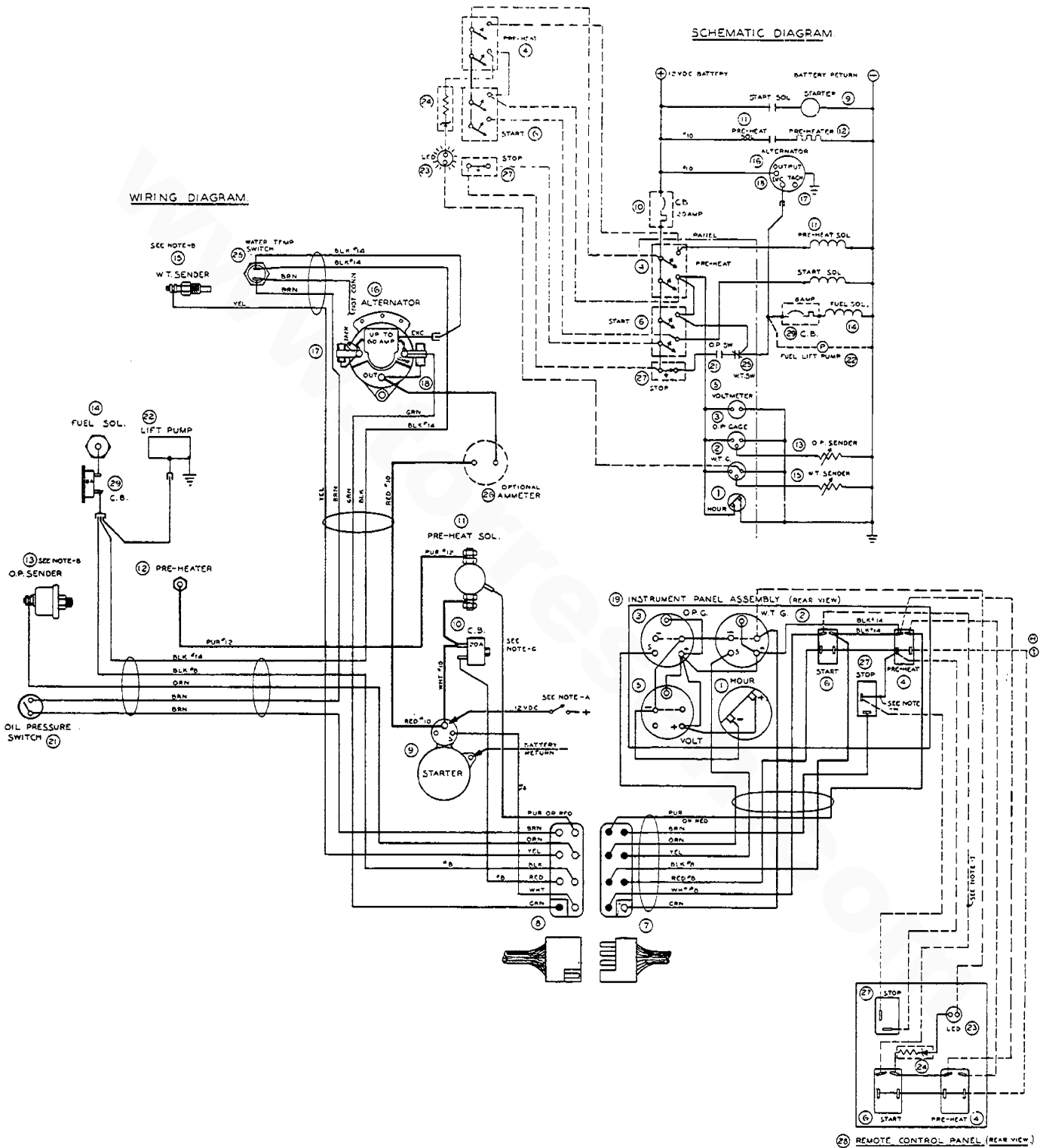

MANUAL STARTER DISCONNECT (TOGGLE SWITCHES)

GENERAL:

This manually controlled series of Westerbeke marine diesel generators is equipped with toggle switches on the engine control panel and, optionally, at remote panels. The following instructions and methods of correcting minor problems apply only to such toggle switch controls.

All three switches are momentary contact type and serve the following functions:

1. Preheat: The PREHEAT/DEFEAT toggle switch is a double pole, single throw switch. The switch serves two purposes: preheating the engine for easy starting and defeating or bypassing the engine protective oil pressure switch. The defeat function turns on the fuel solenoid, instrument power and alternator excitation.
2. Start: The START/DEFEAT toggle switch is a double pole, single throw switch. The switch also serves two purposes: starting the engine and defeating or bypassing the oil pressure switch. The latter pole serves the same function as in the preheat switch.
3. Stop: The STOP toggle switch is a single pole, single throw, normally closed switch. This switch provides power to the fuel solenoid, instrument cluster and alternator excitation, after the oil pressure switch has closed upon starting. Opening of this switch opens the power circuit to the fuel solenoid, thus stopping the flow of fuel to the engine and stopping the engine.

ENGINE OPERATION:

1. Preheat: Depress the PREHEAT switch. The voltmeter, panel lights, gauges and meters and fuel solenoid will activate. The PREHEAT switch should be depressed for twenty seconds in conjunction with thermostarts (installed in intake manifold) and forty to sixty seconds in conjunction with glowplugs.
2. Start: While still depressing the PREHEAT switch, depress the START switch. This will engage the start solenoid. Panel power and the fuel solenoid will be activated. Upon engine firing, release the start switch. Do not release the PREHEAT switch until oil pressure reaches 15 psi. Then as long as the high water temperature and low oil pressure protective circuit does not activate, the set will remain energized and continue to run.
3. Stop: Depress the STOP switch to stop the engine. This opens the power feed to the fuel solenoid, stopping the fuel flow to the engine. It must be depressed until the generator stops rotating.

REMOTE ENGINE OPERATION:

For remote operation of the generator system, the same three switches are used. The PREHEAT and START switches are connected in parallel with the local panel switches and serve the same functions as in the local panel. The STOP switch is in series with the local panel STOP switch, and serves the same functions as in the local panel. The generator may be stopped from local or remote positions.

AC GENERATORS:

Once the diesel generator sets have been placed in operation, there is little or no control adjustment required by the A.C. Generator. When starting the generator, it is always a good plan to switch off all A.C. loads, especially large motors, until the engine has come up to speed and, in cold climates, starts to warm up. These precautions will prevent damage by unanticipated operation of A.C. machinery and prevent a cold engine from being stalled.

OVERSPEED (If equipped with this option):

If the engine governor loses control and the engine speed accelerates, a relay is actuated that de-energizes the fuel solenoid and stops the engine. A red light on the panel illuminates and remains lighted. To extinguish the light, reset the overspeed relay by depressing the engine STOP switch. When the reason for the overspeed shutdown is corrected, the engine is ready to be restarted.

TROUBLESHOOTING

MANUAL STARTER DISCONNECT (TOGGLE SWITCHES)

CIRCUIT PROTECTION:

The engine control system is protected by a 20 amp manual reset circuit breaker located on the engine as close as possible to the power source. An additional circuit breaker is located at the fuel solenoid (P/N 23041) when this solenoid is used. (This solenoid is not used on models which have a solenoid built into the injection pump.)

Manual Control (toggle switch) troubleshooting.

<u>Problem</u>	<u>Probable Cause</u>	<u>Verification</u>
Preheat depressed, no panel indications, fuel solenoid not energized.	Battery switch or power not on  20 amp circuit breaker tripped	Check switch and/or battery connections.  Reset breaker if opens again, check preheat solenoid circuit and "run" circuit for shorts to ground.
Start depressed, no panel indications, fuel solenoid not energized. Start solenoid not engaged.	Battery switch or power not on  20 amp circuit breaker tripped	Check switch and/or battery connections.  Reset breaker. If opens again check start solenoid circuit and "run" circuit for shorts to ground.
Start depressed, panel indications O.K. Start solenoid O.K. Fuel solenoid not functioning.	Fuel solenoid (P/N 23041) circuit breaker tripped	1. Check mechanical positioning of fuel solenoid for plunger bottoming. 2. Reset breaker and repeat start cycle. 3. If repeated tripping, check for defective breaker or fuel solenoid.
No ignition, cranks, does not start. Fuel solenoid energized.	Faulty fueling system	1. Check for fuel to generator system. 2. Check for air in fuel system (bleed system). 3. Fuel lift pump failure.



Failure to stop.	Fuel solenoid (P/N 23041) return spring	Stop engine by freeing fuel pump lever. That failing, shut off fuel. Check fuel solenoid linkage and repair for free movement.
	Stop switch failure	Disconnect power leads thru stop switch. Test switch for proper oper- by continuity test.
	Fuel injection pump failure	Stop engine with fuel line shut off.
Engine stops.	Low oil pressure or overheated	Check oil, fresh water and sea water cooling.
	Low oil pressure switch fails to close	Check for satisfactory operation with switch bypassed.
	High water tempera- ture switch open at too low a temperature	Same as above.
	Switch and wiring	Inspect all wiring for loose connections and short circuits.
Not charging battery.	Alternator drive	Check drivebelt and its tension. Be sure alter- nator turns freely. Check for loose connec- tions.
	Regulator unit and alternator ("MA" series only)	With engine running, mo- mentarily connect B+ to field. A good alternator will produce a high charge (50 amps). If no response, replace alter- nator. Check for short- ing of alternator output connections to ground.
Battery runs down	Oil pressure switch	Observe if gauges and light are on when engine is not running. Test the normally open oil pressure switch by dis- connecting one lead. If lights go out, replace oil pressure switch.

Battery runs down	High resistance leak to ground	Check wiring. Insert sensitive (0-.25 amp) meter in battery lines. (Do not start engine.) Remove connections and replace until short is located.
	Low resistance leak to ground	Check all wires for temperature rise to locate fault.
	Alternator	Disconnect alternator at output, after a good battery charging. If leakage stops, replace alternator protective diode plate. That failing, replace alternator.

OPERATING INSTRUCTIONS  
60 HZ SINGLE BEARING ALTERNATORS  
SINGLE AND THREE PHASE

GENERAL

The solid state voltage regulated alternators described herein have been built to give lasting and reliable maintenance free service in their intended application(s) and are SCA certified. Should a situation arise where the alternator fails to operate properly and all mechanical conditions are found to be satisfactory, refer to the electrical section of this manual as an aid in analyzing the cause and effecting a repair.

INSTALLATION

1. The alternator intake and exhaust airways must be kept free of obstructions during operation of the alternator. If the flow of cooling intake air or heated exhaust air is inhibited, eventual alternator overheating and subsequent failure of the alternator to operate may occur.
2. Care should be exercised during the electrical hookup to the alternator output, so as not to damage the voltage regulating circuits found within the control box. See figure 4 for alternator connection diagram.

OPERATION

NOTE:

1. Do not exceed the maximum alternator shaft speed of 2200 RPM as permanent alternator damage may result.
2. If there are unusual noises from the alternator at any time during its operation, shut it down and check for internal mechanical wear and/or damage.
3. For the protection of line frequency sensitive loads that may be connected to the alternator, only operate at an alternator shaft speed of 1800 RPM (60 Hz).

These alternators are classed drip proof. The air intake and outlets are covered with an expanded metal screen to protect against the ingestion of airborne litter. These screens need not be removed for cleaning. DO NOT operate the alternator without these screens in place.

There are no set up adjustments for the alternator. However, if the value of the output voltage is inconsistent with given specific requirements, then it may be adjusted over a narrow  $\pm 5\%$  range and will not normally require readjustment.

To adjust the output voltage, remove the cover from the control box and locate the voltage setting control per figure 1. Using an insulated tool, operate this control to obtain the desired output voltage. Right hand rotation of this control increases the output voltage.

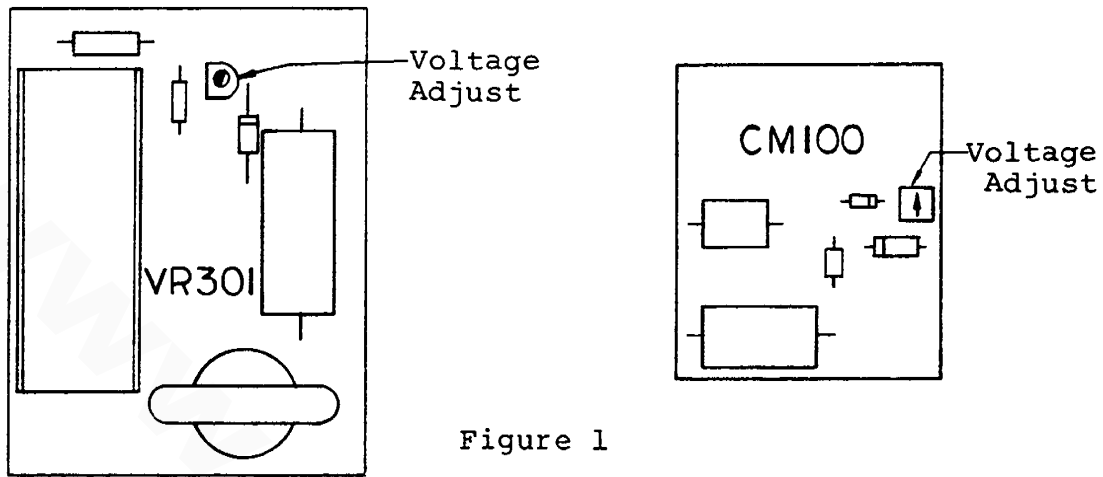

Figure 1

CAUTION

TERMINALS AND COMPONENTS CARRYING LINE VOLTAGE MAY BE EXPOSED WITHIN THE CONTROL BOX AND VOLTAGE REGULATING CIRCUITS WHEN THE ALTERNATOR IS OPERATING. THEREFORE THE USE OF NON-CONDUCTING TOOLS IS ESSENTIAL FOR SAFETY REASONS. ONLY QUALIFIED ELECTRICIANS OR PERSONS THOROUGHLY FAMILIAR WITH ELECTRICAL EQUIPMENT SHOULD ATTEMPT THIS ADJUSTMENT

PREVENTATIVE MAINTENANCE - MECHANICAL

The alternator is virtually maintenance free and is designed to give 5000 hours of trouble free service. Periodic inspection is suggested to assure the alternator airways do not become obstructed.

CORRECTIVE MAINTENANCE

The alternator can be dismantled from the engine using standard hand tools. See figure 2 for dismantling information.

Some minor repairs and tests can be done without dismantling the alternator. One example is the shaft mounted rectifier. See figure 3 for the checking and/or replacing procedure.

## INSTALL RECTIFIER

With heatsink compound (DC #340 or equivalent) tighten to maximum torque of 30 inch pounds.

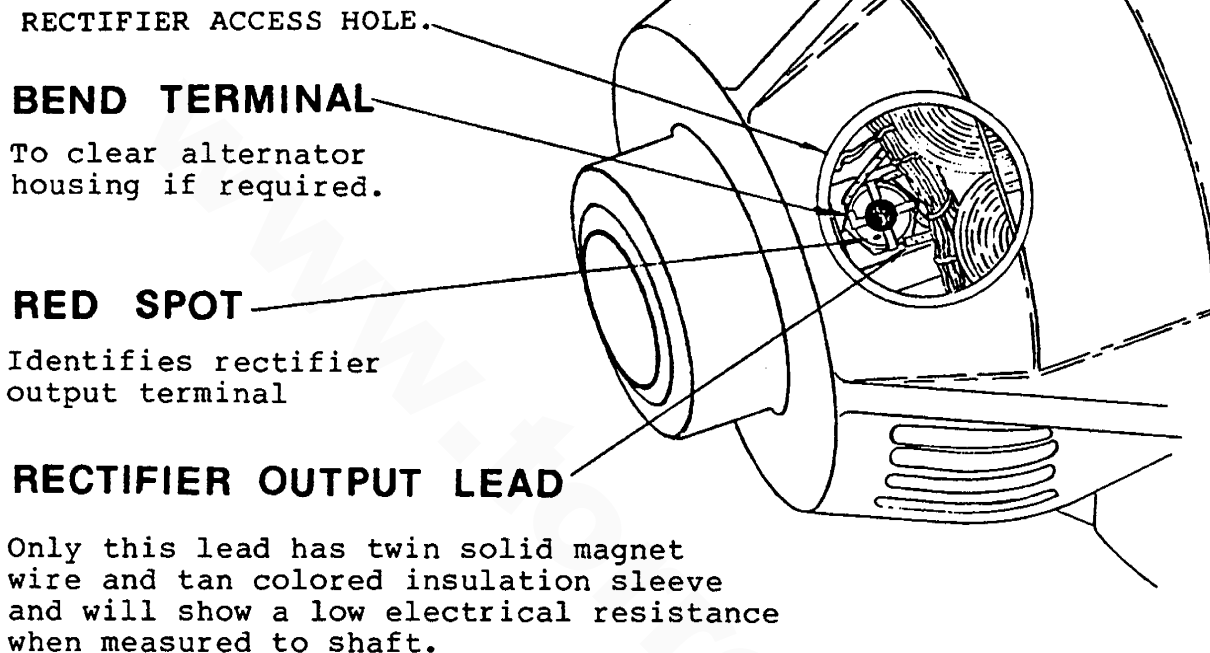

1. Remove the hole cover (item 10) on top anti-drive end of the alternator.
2. Crank engine until the rectifier comes into view and lock to prevent engine from turning the shaft.
3. Unsolder the four wires from the rectifier.
4. Remove the rectifier by unscrewing in counter-clockwise direction then follow testing and replacement procedures described under alternator disassembly above.
5. Replace or reinstall the rectifier reversing the above procedure.

FIGURE 3. BRIDGE RECTIFIER ACCESS

ELECTRICAL FAULT ANALYSIS

An understanding of the alternator's principle of operation may be useful before attempting to analyze an electrical failure; therefore a brief description follows. See figure 4, Schematic Diagram.

The alternator is a brushless, self-excited type requiring only driving force.

One permanent magnet in the six pole exciter stator is responsible for the self-exciting feature of the alternator. Its magnetic field causes a voltage to be induced into the associated exciter rotor coils during rotation. This AC voltage is full wave rectified and applied to the main rotating field coil. The resulting electro-magnetic field induces an alternating voltage into the associated main stator coils and a resulting current will flow to the output terminals.

Simultaneously, an auxiliary coil on the main stator generates an AC voltage which is full wave rectified and employed as a source of supply for the remaining five electro-magnetic poles on the exciter stator. The voltage regulator controls the current flow to these poles, thereby effecting voltage regulation.

FAULT ANALYSIS

<u>SYMPTOM</u>	<u>PROBABLE CAUSE</u>	<u>REPAIR PROCEDURE</u>
1. Mechanical Noise	a) Defective bearing.	Replace bearing.
	b) Worn bearing.	Replace bearing.
	c) Loose or misaligned coupling.	Align and/or tighten.
	d) Foreign objects within.	Remove and check further for possible damage.
2. No Output	a) Short or open circuits in any stator or rotor coil, or associated leads.	Contact Westerbeke if repair is beyond local facilities. Check grounding lead and terminal on shaft behind main rotor coil.
	b) Defective bridge rectifier on shaft (see figure 3).	Replace if faulty and check further for cause.
	c) Faulty voltage regulating circuit.	Repair or replace if faulty and check further for cause.
3. High Output Voltage	a) Misadjusted output voltage control (see figure 1).	Set output voltage to desired value. CAUTION: SOME COMPONENTS CARRY LIVE VOLTAGE AND THE USE OF INSULATED TOOLS IS RECOMMENDED.

- b) Wire T2 (120/240V) or T6 (120/208) or T12 (120/208 /416 - 120/240) unground. Clean and/or remake this ground connection.
- c) Faulty voltage regulating circuit Repair or replace if faulty and check further for cause.
4. Low Output Voltage
- a) Misadjusted output voltage control (see figure 1). Set output voltage to desired value. CAUTION: SOME COMPONENTS CARRY LIVE VOLTAGE AND THE USE OF INSULATED TOOLS IS RECOMMENDED.
- b) High line loss if voltage is low only at load(s). Increase the size of the wiring leading to the load(s) as required. Load wires should not run hot at continuous full load if properly sized. Do not run a greater length of wire than required as losses increase with distance. If wire is correctly sized and is not too long, check for poor connections and/or partly broken wires that may be indicated by hot spots in the wire or at terminals of switches, etc.
- c) Partially shorted main rotor field coil. Contact Westerbeke if repair is beyond local facilities.
- d) Electrical overload, and/or poor power factor connected to alternator The total load at the prescribed power factor (see identification plate on alternator) should not be exceeded.
- e) Alternator shaft RPM too low. Check engine speed.
- f) Faulty voltage regulating circuit. Repair or replace if faulty and check further for cause.
5. Unstable Output Voltage
- a) Irregular engine speed. Check engine and loads for transient operation and/or overloads.

- |                            |  |  |
|----------------------------|--|--|
|                            | b) Loose electrical connections.   | Tighten connections as required in load wiring and voltage regulating connector.   |
|                            | c) Faulty voltage regulating circuit or connector                        | Repair or replace if faulty and check further for cause.   |
|                            | d) Higher than required engine speed.                                    | Check speed is 1800 RPM.   |
| 6. Overheating             | a) Airways blocked.  | Remove obstruction.  |
|                            | b) High ambient temperature.   | Do not permit ambient temperature to exceed 40°C (104°F) and operate in a well ventilated and shaded area if necessary.  |
|                            | c) Electrical overload and/or poor power factor connected to alternator. | The total load at the prescribed power factor (see identification plate on alternator) should not be exceeded.   |
|                            | d) Engine exhaust being drawn into alternator air intake.                | Redirect engine exhaust as required to prevent this from happening.  |
| 7. Alternator Housing Live | a) Static charge.  | Properly ground frame of alternator.   |
|                            | b) Open circuit at ground bar in control box.                            | Ensure alternator neutral has continuity from stator to ground bar. CAUTION: SOME ELEMENTS WITHIN THE CONTROL BOX CARRY LIVE VOLTAGE WHEN ALTERNATOR IS RUNNING. |



**BASIC SCHEMATIC**

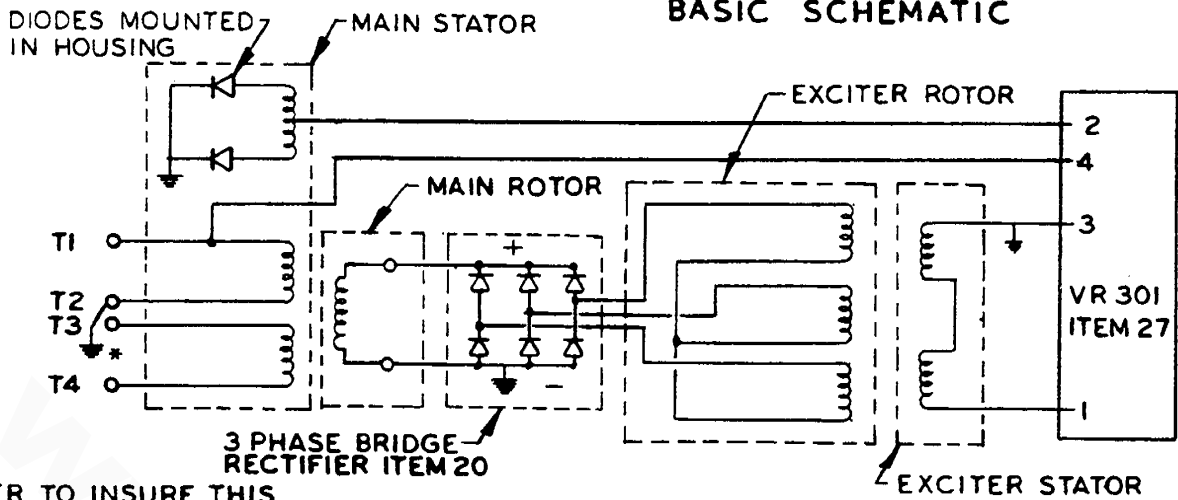

\* USER TO INSURE THIS GROUND CONNECTION IS MADE. **SINGLE PHASE (ALL)**

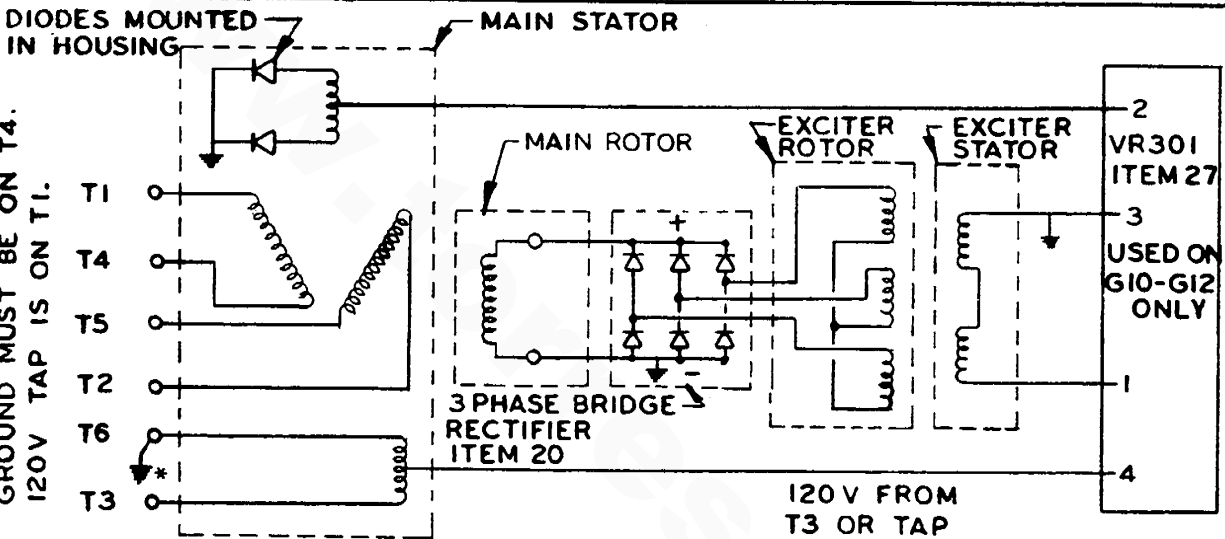

NOTE: 60Hz - 200 UNITS USE CM100 CONTROL MODULE & USER'S GROUND MUST BE ON T4. 120V TAP IS ON T1.

\* USER TO ENSURE THIS GROUND CONNECTION IS MADE. **THREE PHASE (TYPICAL 6 WIRE) EXCEPT -200 SERIES 60 H.z. SEE NOTE**

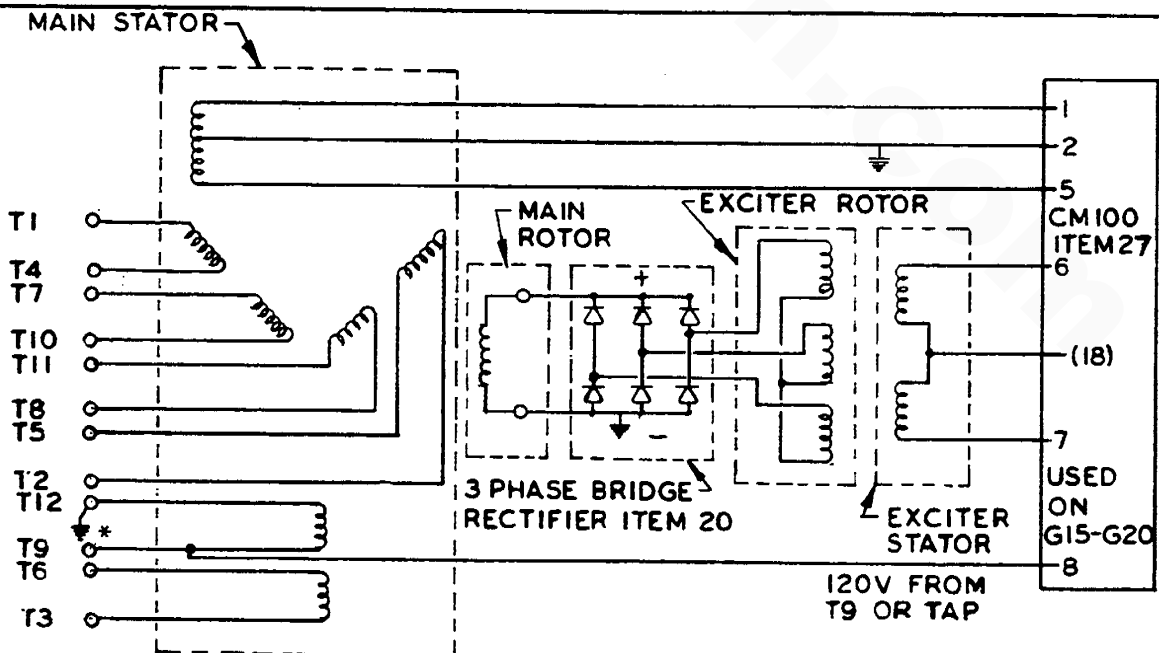

\*USER TO ENSURE THIS GROUND CONNECTION IS MADE. **THREE PHASE (TYPICAL 12 WIRE)**

ALTERNATOR CONNECTION DIAGRAM

6 WIRE 3 PHASE ALTERNATOR

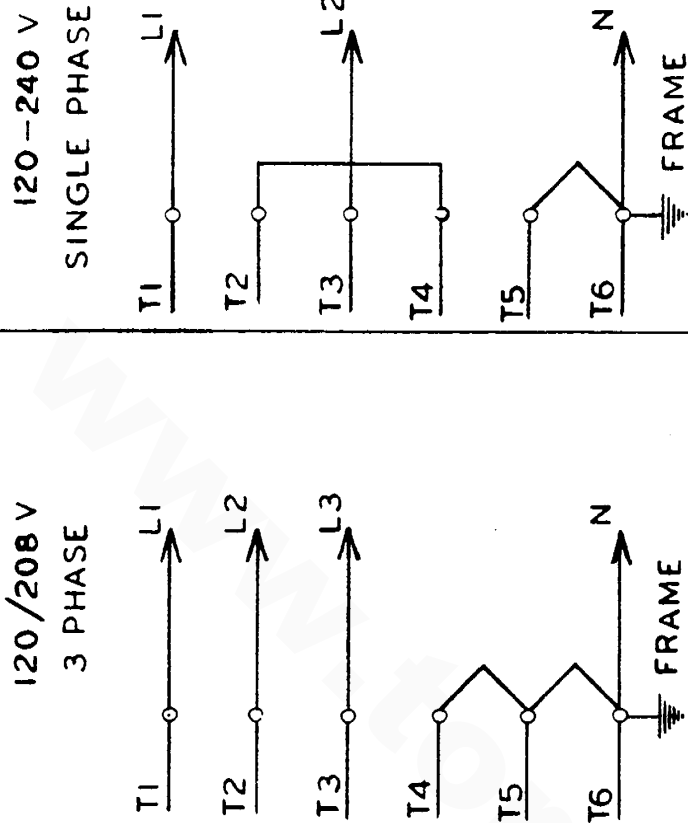

SINGLE PHASE ALTERNATOR

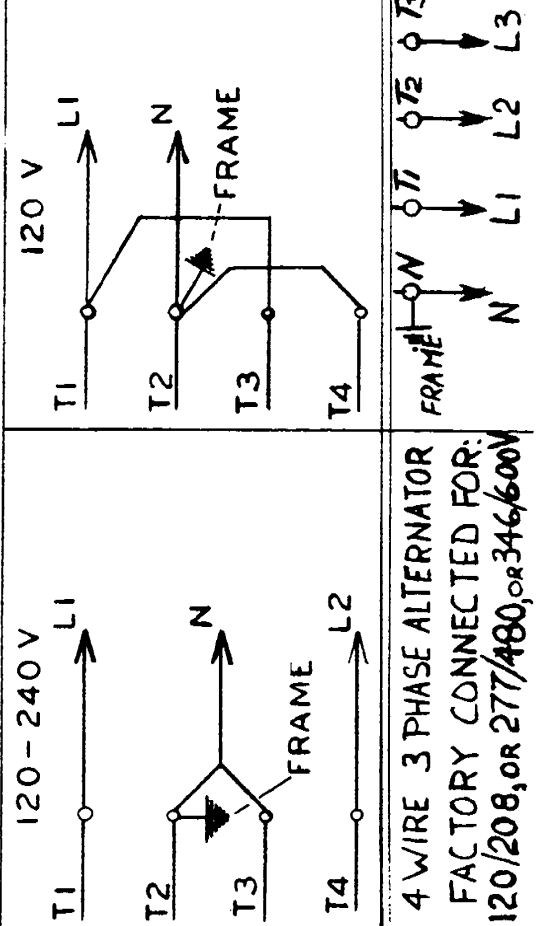

12 WIRE 3 PHASE ALTERNATOR

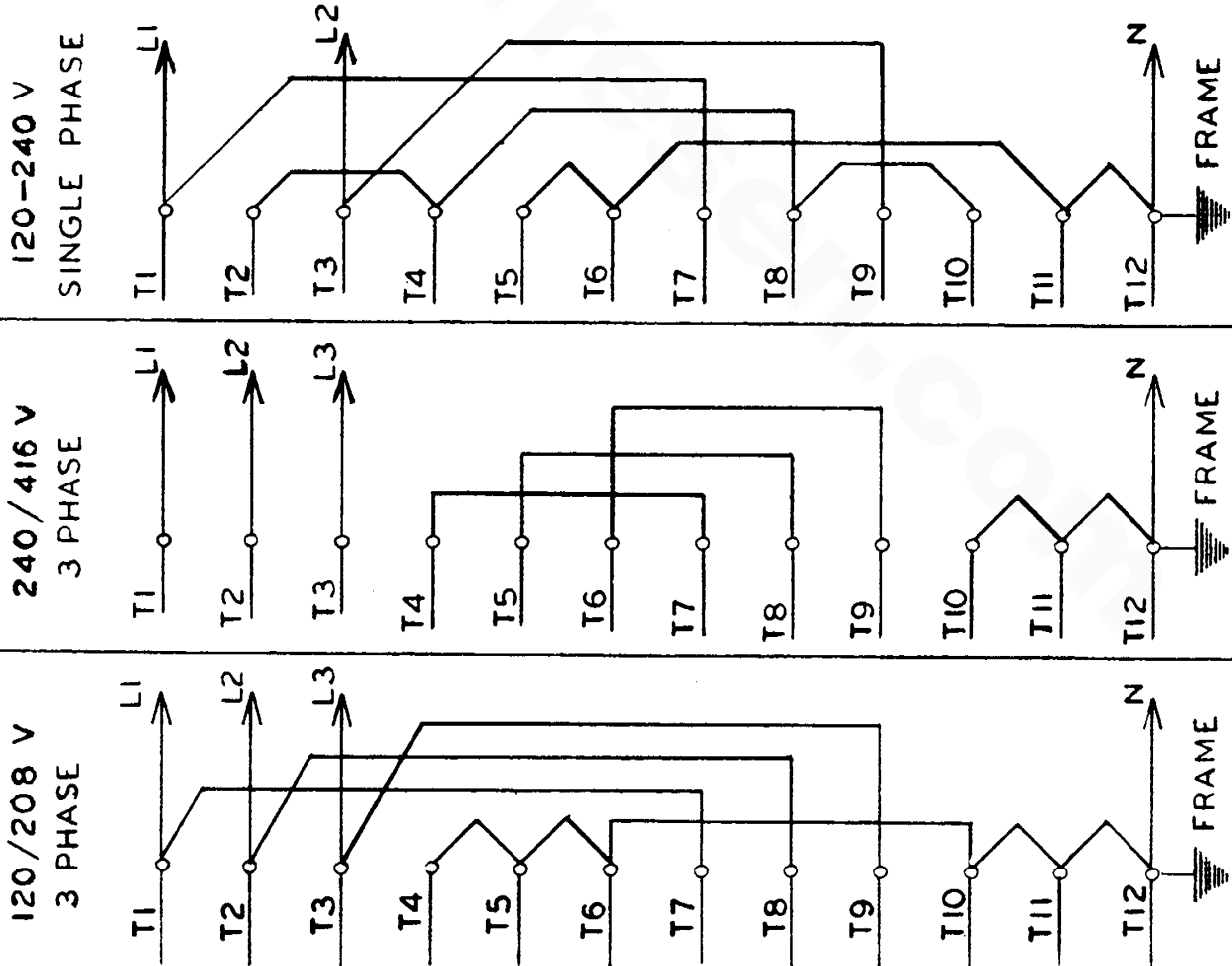

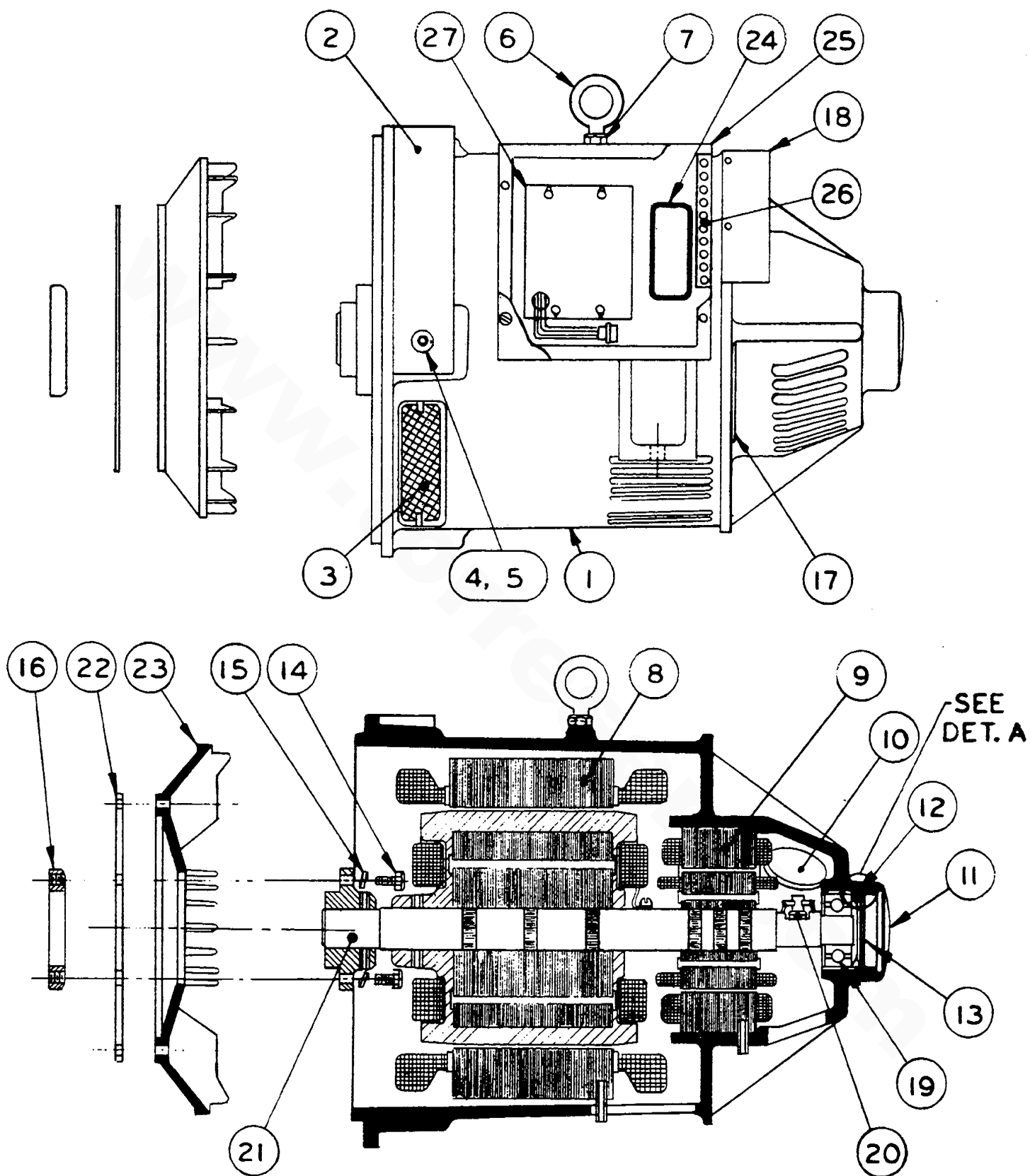
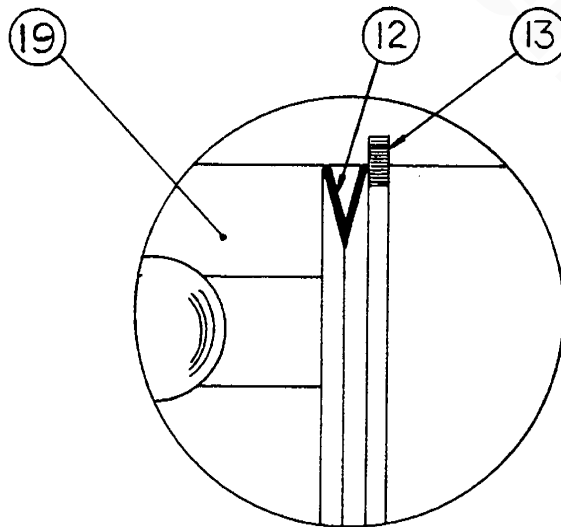

Figure 2

PARTS IDENTIFICATION

- 1 Stator Housing
- 2 Drip Shroud - Exhaust Air
- 3 Exhaust Air Screen (4)
- 4 Helical Lockwasher, 0.25 (3)
- 5 Round Head Screw, 0.25-20 x 0.5" (3)
- 6 Eyebolt
- 7 Nut, 0.375-16 UNC
- 8 Main Stator
- 9 Excitor Stator
- 10 Snap Cover 2.25" Dia.
- 11 Snap Cover 3.00" Dia.
- 12 Belleville Washer
- 13 Retaining Ring
- 14 Cap Screw, 0.312-18 UNC x 1.25" (6)
- 15 Lockwasher Split, 0.313 (6)
- 16 Clamping Ring
- 17 Inlet Air Screen (4)
- 18 Drip Shroud - Inlet Air
- 19 Ball Bearing (Anti-drive End)
- 20 Bridge Rectifier
- 21 Complete Rotor/Shaft Assembly
- 22 Disc Drive (4) or (5)
- 23 Fan
- 24 Continuous Grommet
- 25 Steel Control Box (incl. Cover)
- 26 Neutral (Ground) Terminal Strip
- 27 Voltage Regulator

NOTE: When ordering spare parts, please give reference number, description, model and serial number of both engine and generator.



DETAIL A

## **YOUR NOTES**

[www.torresen.com](http://www.torresen.com)

# YD GENERATORS

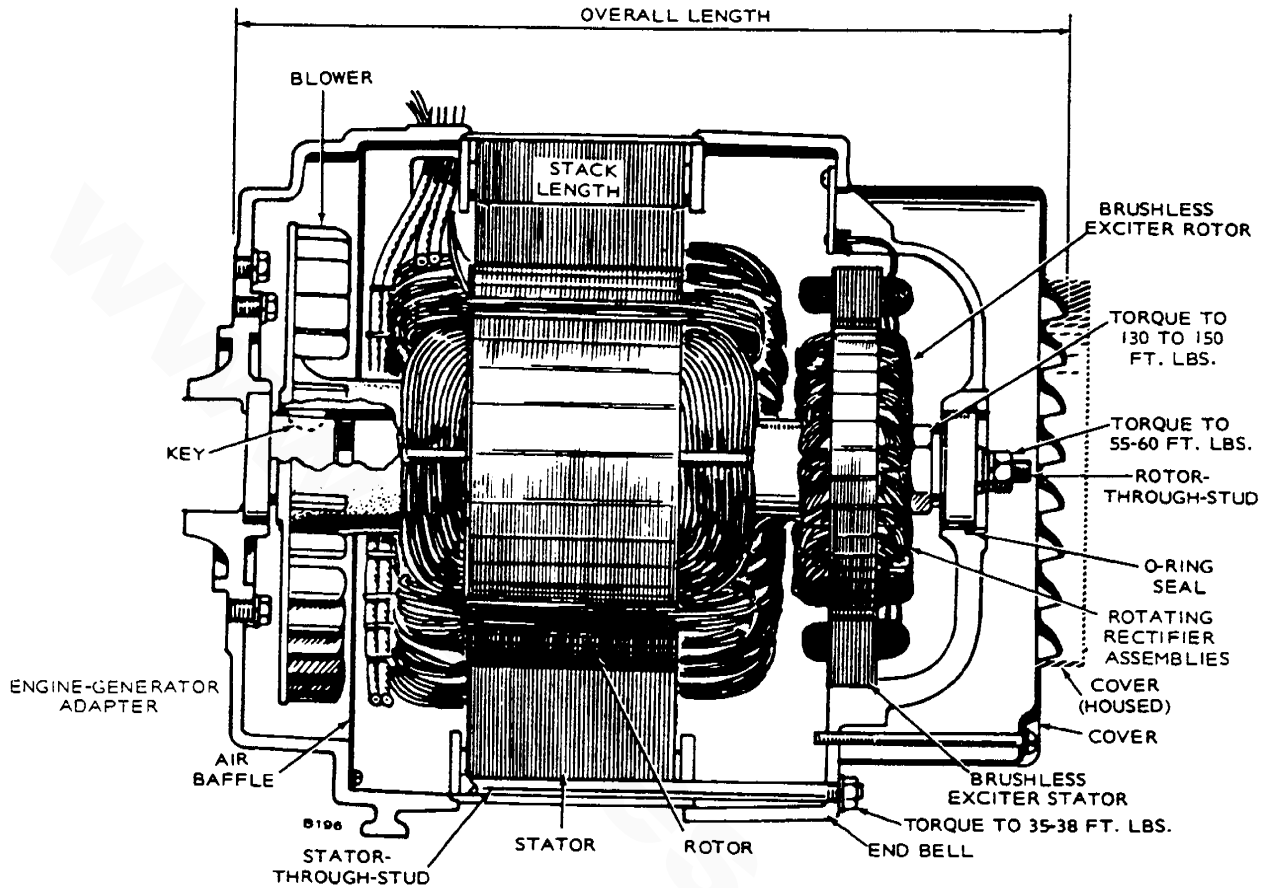

FIGURE 1. GENERATOR (SECTIONAL VIEW)

## AC GENERATOR DESCRIPTION

The YD generators beginning with Spec AA (Figure 1) are four-pole, revolving field, brushless exciter, reconnectable models of drip-proof construction. Generator design includes both single and three-phase, 60 and 50 hertz type generators. The generator rotor connects directly to the engine crankshaft with a tapered shaft and key. The generator is fastened to the engine by the rotor-through-stud which passes through the rotor shaft; it has a nut on the outside of the end bell. A centrifugal blower, on the front end of the rotor shaft, circulates the generator cooling air which is drawn in through the end bell cover and discharged through an outlet at the blower end.

A ball bearing in the end bell supports the outer end of the rotor shaft. The end bell and generator stator housing are attached by four-through-studs which pass through the stator assembly to the engine-generator adapter. The brushless exciter stator mounts in the end bell while the exciter rotor and its rotating rectifier assemblies mount on the generator rotor shaft.

F<sup>1+</sup> and F<sup>2-</sup> are from the exciter field winding and are

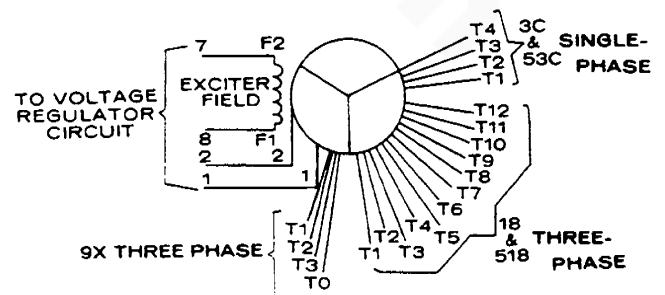

FIGURE 2. SINGLE AND THREE PHASE GENERATOR SCHEMATIC (COMPOSITE)

connected to the output terminals of the voltage regulator. Leads 1 and 2 are connected to the stator windings and provide reference voltage and input power to the voltage regulator. These five leads are connected at the factory.

Figure 2 is a composite illustration showing four output leads for single-phase units, 12 output leads for 3-phase broad range units, and four output leads for code 9X 3-phase 347/600 volt generators.

### GENERATOR OPERATION

The basic operation of the generator and voltage regulator involves the stator, voltage regulator, exciter field and armature, a full wave bridge rectifier, and the generator rotor, Figure 3. Residual magnetism in the generator rotor and a permanent magnet embedded in one exciter field pole begin the voltage build-up process as the generator set starts running. Single-phase AC voltage, taken from one of the stator windings, is fed to the voltage regulator as a reference voltage for maintaining the generator output voltage. The AC reference voltage is converted to DC by a silicon controlled rectifier bridge on the voltage regulator printed circuit board and fed into the exciter field windings. The exciter armature produces three-phase AC voltage that is converted to DC by the rotating rectifier assembly. The resultant DC voltage excites the generator rotor winding to produce the stator output voltage for the AC load.

The generator rotor also produces AC voltage in the charging winding of the stator which is converted to direct current for battery charging.

### VOLTAGE REGULATOR

The line-voltage regulator (VR22 or VR23) on the Spec AA J-Series generator sets is an all solid state device; that is, no relays or tubes are needed. Basic components of the voltage regulator are:

- Printed circuit board VR21
- Voltage reference transformer T21
- Commutating reactor CMR21
- Field circuit breaker CB21
- Voltage adjust rheostat R22 (Optional)

Figure 4 shows the above components and voltage regulator wiring diagrams for typical control boxes on electric generating sets. The electrical schematic and printed circuit board are shown in Figure 5.

The voltage adjust rheostat (R<sup>22</sup>) is optional on either VR<sup>22</sup> or VR<sup>23</sup> voltage regulator assembly. When R<sup>22</sup> is used, it is connected between VR<sup>21-1</sup> and VR<sup>21-3</sup> (Figure 5) and the jumper between VR<sup>21-1</sup> and VR<sup>21-2</sup> (Figure 4) is removed.

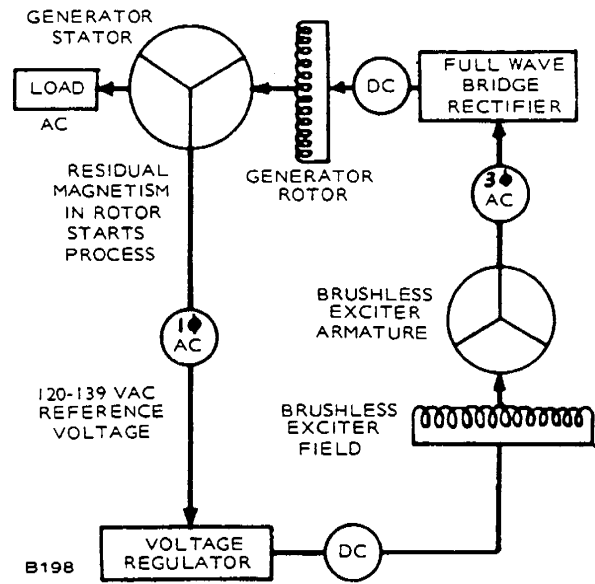

FIGURE 3. EXCITATION BLOCK DIAGRAM

### INSTALLATION AND RECONNECTION CAPABILITIES

YD generators have the capability of being operated in a number of different voltage connections, and at different voltages in a single connection. The connections and voltages which can be obtained from a given generator are defined by the generator voltage code on the nameplate and listed in Figure 6.

**CAUTION** To prevent generator damage, do not attempt to operate a generator with a given voltage code in any connection or at any voltage not listed for that voltage code.

**NOTE 1.** When connecting the generator output leads for a new or different connection or when the operating voltage of a single voltage connection is to be changed, be sure that jumper wire W10 on VR<sup>21</sup> is properly connected from terminal V<sup>4</sup> to V<sup>1</sup>, V<sup>2</sup>, or V<sup>3</sup> as listed in Figure 6 to provide the correct reference voltage.

**NOTE 2.** Connect the wire from transformer T<sup>21</sup>-X<sup>1</sup> to terminal VR<sup>21-5</sup> for code -53C and -518 (50 Hertz) generators. Connect T<sup>21</sup>-X<sup>1</sup> to VR<sup>21-6</sup> for code -3C, -18, and -9X (60 Hertz) generators. Connect the rest of the wires on the voltage regulator assembly according to the wiring diagram and wiring tabulation chart which applies to your generator set.

Generator sets without a control panel or switchboard containing AC instruments such as voltmeters, ammeters, running time meter, frequency meters, and line circuit breakers are shipped from the factory with the AC output leads separated in the output box. On generator sets with switchboards containing AC instruments, the AC output leads are wired as specified on the customer's purchase order to deliver only the voltage specified.

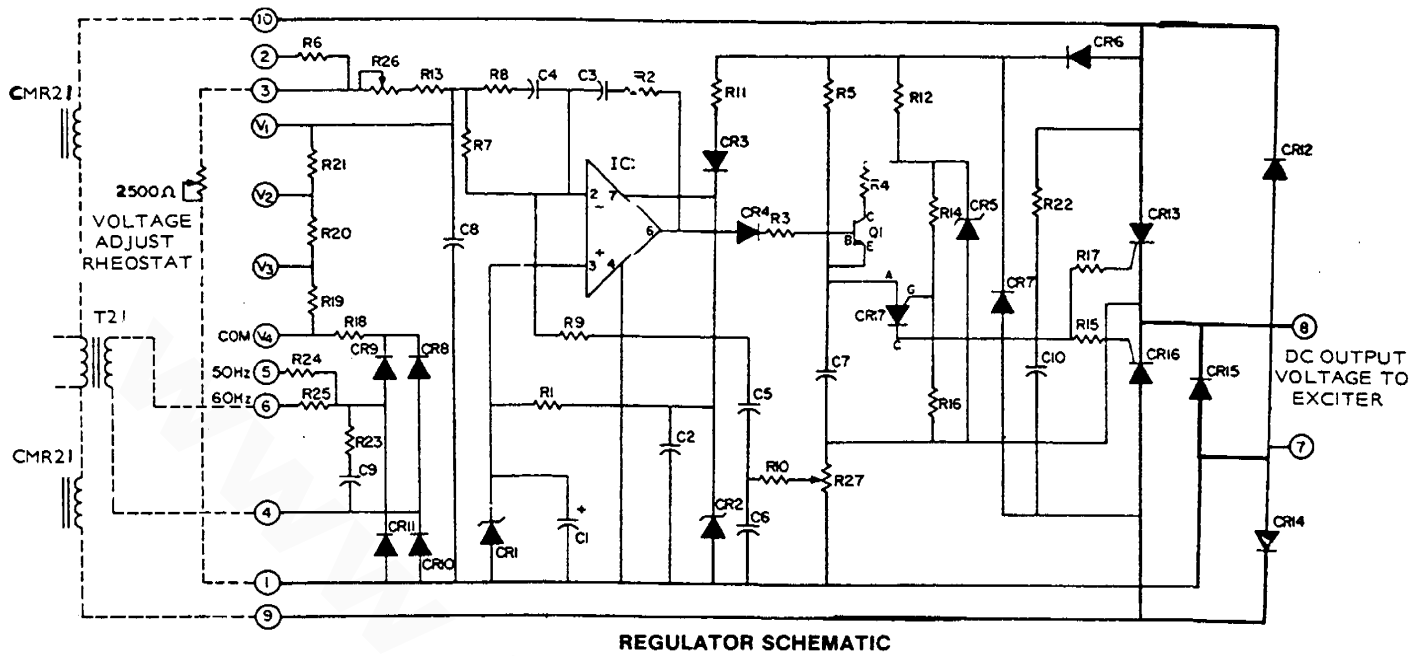

REGULATOR SCHEMATIC

REF. DES.	DESCRIPTION
IC1	Integrated Circuit
Q1	Transistor-NPN
T21	Transformer, Reference Voltage
CMR21	Commutating Reactor
R27	Potentiometer W.W. 8K-Ohm
R26	Potentiometer W.W. 2.5K-Ohm
R25	Resistor-Film 42.2K-Ohm, 1/4W
R24	Resistor-Film 46.4K-Ohm, 1/4W
R23	Resistor 10-Ohm, 1/2W
R22	Resistor 820-Ohm, 2W
R21	Resistor-Film 2.67K, 1/4W
R20	Resistor-Film 1.53K, 1/4W
R19	Resistor-Film 3.09K, 1/4W
R18	Resistor-Film 28.0K, 1/4W
R16	Resistor 8.2K-Ohm, 1/2W
R15,17	Resistor 180K-Ohm, 1/2W
R14	Resistor 2700-Ohm, 1/2W
R13	Resistor-Film 12.1K-Ohm, 1/4W
R11,12	Resistor-Wire Wound 4K, 5W
R9	Resistor 1 MEG Ohm, 1/2W
R8-10	Resistor 100K-Ohm, 1/4W
R7	Resistor 270K-Ohm, 1/2W
R6	Resistor-Film 1.74K-Ohm, 1/4W
R5	Resistor 2 MEG Ohm, 1/2W
R4	Resistor 3K-Ohm, 1/2W
R3	Resistor 330K-Ohm, 1/2W
R2	Resistor 220K-Ohm, 1/2W
R1	Resistor 33K-Ohm, 1/2W
CR17	Transistor-Unijunction
CR13,16	Rectifier-Gate Control
CR12,14,15	Rectifier-Diode
CR5	Diode-Zener 18V
CR3,4,6-11	Rectifier-Diode 400MA 400V
CR2	Diode-Zener 20V
CR1	Diode-Zener 5.6V
C10	Capacitor .47MFD 400V
C9	Capacitor .39MFD 100V
C8	Capacitor 1MFD 100V
C4, C5	Capacitor .1MFD 200V
C3, C7	Capacitor .22MFD 200V
C2, C6	Capacitor .47MFD 100V
C1	Capacitor-Electrolytic 100MFD 10V

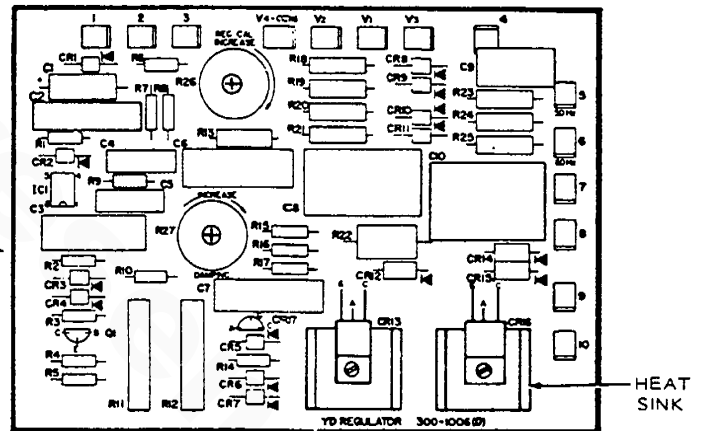

PRINTED CIRCUIT BOARD, VR21

NOTE: The 2500 ohm external voltage adjust potentiometer connects between pin 1 and pin 3. See regulator schematic. If your set does not have an external voltage adjust potentiometer, pin 1 is jumpered to pin 2. See Figure 4.

FIGURE 5. VOLTAGE REGULATOR PRINTED CIRCUIT BOARD



NAMEPLATE VOLTAGE CODE	VOLTAGE	PHASE	FREQUENCY	CONNECT W/IO JUMPER WIRE FROM V1 TO:	GENERATOR CONNECTION	GENERATOR CONNECTION SCHEMATIC DIAGRAM	LOAD TO GENERATOR CONNECTION WIRING DIAGRAM
3C	120/240	1	60	V1	A		<p>LOAD TO GENERATOR CONNECTION WIRING DIAGRAM</p> <p>CONNECT X1 TO VR21-5 FOR 50 HERTZ; CONNECT X1 TO VR21-6 FOR 60 HERTZ GENERATORS.</p>
53C	120/240	1	50	V1			
	115/230	1	50	V2			
	110/220	1	50	V3	B		
18	120/208 127/220 139/240	3	60	V1	PARALLEL WYE		
518	110/190 115/200 120/208 127/220	3	50	V1			
		3	50	V2			
18	240/416 254/440 277/480	3	60	V1	SERIES WYE		
518	220/380 230/400 240/416 254/440	3	50	V1			
		3	50	V2			
18	120/240	3	60	V1	SERIES DELTA		
518	110/220 115/230 120/240	3	50	V1			
		3	50	V2			
18	120/240	1	60	V1	DOUBLE DELTA		
518	110/220 115/230 120/240	1	50	V1			
		1	50	V2			
18	120	1	60	V1	PARALLEL DELTA		
518	110 115 120	1	50	V1			
		1	50	V2			
9X	347/600	3	60	V4	WYE		

FIGURE 6. GENERATOR WIRING AND RECONNECTION DIAGRAMS

### **VOLTAGE RECONNECTION WITH OPTIONAL INSTRUMENTS**

The optional AC instruments on the control panel (such as voltmeters, ammeters, transformers, and running time meters) are intended for use with specific nameplate voltages. Control components may have to be changed to match new current ratings when field reconnection for other voltage codes or voltages are made.

**Under no circumstances shall the generator be connected in any other manner than shown in Figure 6.**

**Severe damage will result if leads are incorrectly connected or improperly insulated. Use extreme care in checking leads to assure proper connections.**



# ADJUSTMENTS AND TESTS

## GENERAL

The adjustment and test procedures herein are referenced in the generator troubleshooting tables, pages 18-20. The following information is needed by servicemen to effectively service or repair J-series generators beginning with Spec AA.

### [A]

#### VOLTAGE CALIBRATION ADJUSTMENT

The calibration adjustment is made using an accurate AC voltmeter to observe generator output voltage and to set the correct no load voltage. If voltage regulator VR<sup>21</sup> printed circuit board has been replaced, it may be necessary to make a calibration adjustment. To obtain the correct output voltage, proceed as follows:

1. If set has a voltage adjust potentiometer (R<sup>22</sup>) on the meter panel, set pointer halfway between minimum and maximum positions.
2. With unit running at no load, turn generator voltage potentiometer R<sup>26</sup> on VR<sup>21</sup> (Figure 4) clockwise to increase output voltage; turn R<sup>26</sup> counterclockwise to decrease output voltage.

### [B]

#### VOLTAGE STABILITY ADJUSTMENT

Voltage stability is set at the factory, but if printed circuit board VR<sup>21</sup> has been replaced or if damping potentiometer R<sup>27</sup> has been unnecessarily adjusted it may be necessary to reset stability. Set stability as follows:

1. With generator set running at no load, turn potentiometer R<sup>27</sup> (Figure 4) to a position where voltage tends to be unstable or hunt.
2. Turn R<sup>27</sup> clockwise slowly until voltage first stabilizes. This setting will result in stable voltage under all conditions in maximum voltage regulator response time.

### [D]

#### VOLTAGE REGULATOR CHECKOUT

The solid state voltage regulators (VR<sup>21</sup>) can be checked out on the bench for proper operation or location of faulty components. The following test equipment (one-each) is required for a proper checkout.

REF. DESIGNATION	TEST EQUIPMENT
S	Switch
CMR21	Reactor
F	Fuse, 5 Amps
T1	Transformer, Variable 2 Amp 0-150V
V2	Voltmeter, DC $\pm 2\%$ of Full Scale 3, Scale 0-50 and 0-150V and 0-10V
V1	Voltmeter, AC $\pm 2\%$ @ 10VAC, 1% @ 150V
R1	Resistor, 100-Ohm 400 W
T21	Transformer, Input 315-0386

#### Bench Check:

1. Remove voltage regulator from unit according to procedure given for voltage regulator replacement.
2. Referring to Figure 7 and Table 1, connect test equipment to the printed circuit board VR<sup>21</sup> terminals as follows:

[E]

CONNECT	FROM	TO
Jumper	VR21-V1	VR21-V4
Jumper	VR21-1	VR21-2
Lead	CMR21-1	VR21-10
Lead	CMR21-4	VR21-9
Lead	T21-X1	VR21-6
Lead	T21-X2	VR21-4
AC Voltmeter	Across	T21-H1 & H2
DC Voltmeter	Across	CR21-7 & 8
VARIAC	Across	T21-H1 (fused) and H2

**FLASHING THE FIELD**

The following procedure is used for momentarily flashing the exciter field with a low voltage which restores the residual magnetism in the alternator rotor. Flashing the field is usually necessary when installing a new brushless exciter stator wound assembly, but seldom is necessary under other circumstances. Always check generator residual voltage at terminals 1 and 2 to be certain whether or not flashing the field is necessary. Generator residual voltage should be at least 20 VAC at rated speed. If residual is too low and the output voltage will not build up, flash the field as follows:

3. Open switch in 120 VAC supply to VARIAC.
4. Plug VARIAC into 120 VAC source.
5. Proceed with checkout according to steps in Table 1.

1. Locate terminals 7(-) and 8(+) on voltage

**TABLE 1. VOLTAGE REGULATOR CHECKOUT**

STEP NO.	TEST NAME	PROCEDURE	REQUIREMENTS
			(> = LESS THAN) $V_1$ AC INPUT VOLTAGE $V_2$ DC OUTPUT VOLTAGE (<= MORE THAN)
1	BUILD UP	SET $V_1$ TO 25 VAC	$V_2$ SHALL BE > 12 VDC
2	CALIBRATION	SET $V_1$ TO 120 VAC	SET POT R26 TO HOLD $V_2$ BETWEEN 50-70 VDC
3	RANGE	A. SET $V_1$ TO 123 VAC B. SET $V_1$ TO 125 VAC	$V_2$ SHALL BE < 30 VDC $V_2$ SHALL BE < 10 VDC
4	RANGE	A. SET $V_1$ TO 115 VAC B. SET $V_1$ TO 117 VAC	$V_2$ SHALL BE > 85 VDC $V_2$ SHALL BE > 80 VDC
5	MAX VOLTAGE	SET $V_1$ TO 150 V	$V_2$ < 10 VOLTS
6	DAMPING	SET $V_1$ SO $V_2$ IS NEAR MAXIMUM RAPIDLY TURN POT R27 FROM FULL COUNTER CLOCKWISE POSITION TO FULL CLOCKWISE POSITION. RETURN R27 TO MIDDLE POSITION AFTER TEST	$V_2$ SHOULD DROP TO < 50 VOLTS THEN RISE TO ORIGINAL VALUE.

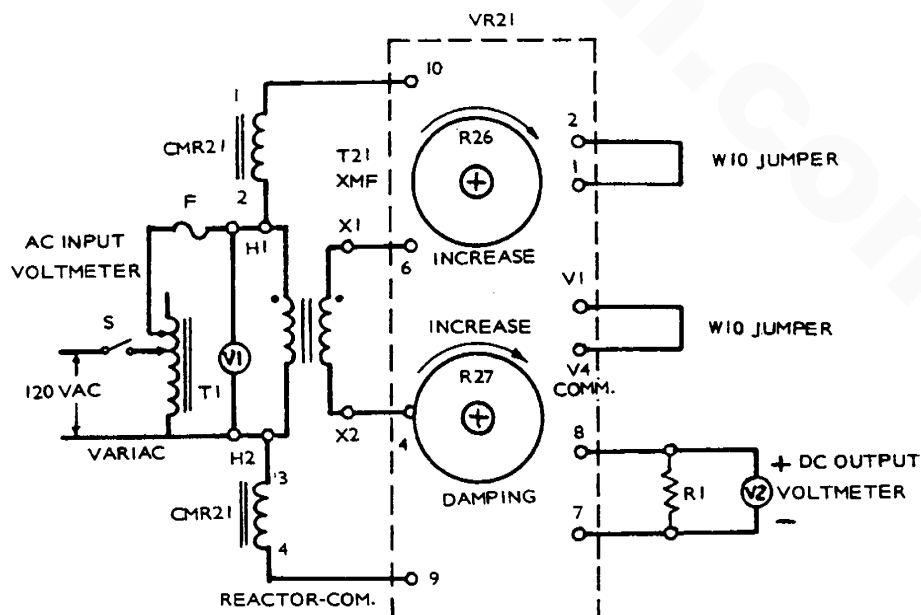

**FIGURE 7. VOLTAGE REGULATOR CHECKOUT TEST EQUIPMENT CONNECTIONS**

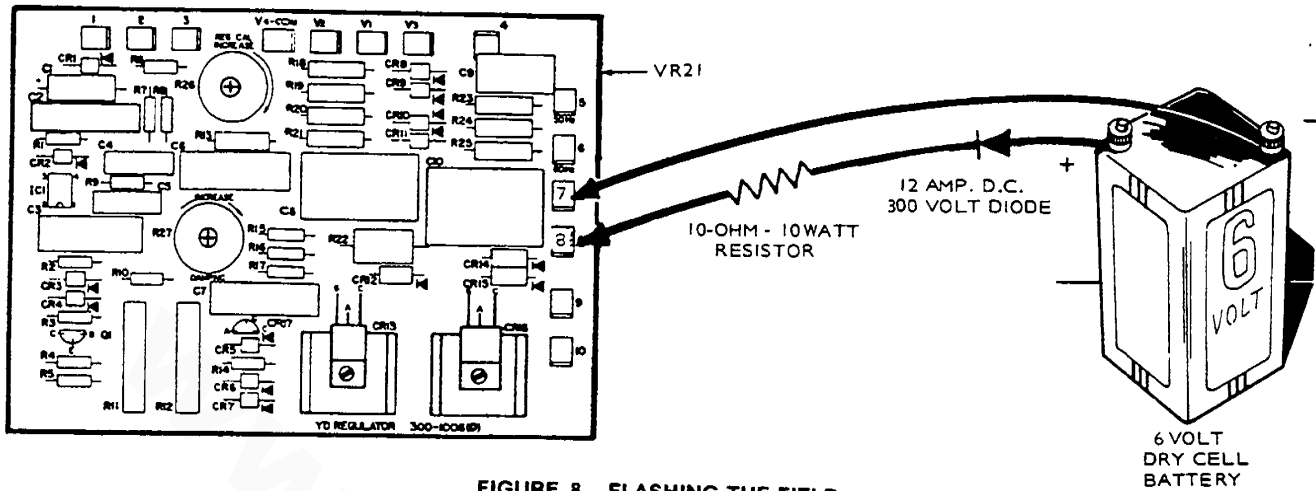

FIGURE 8. FLASHING THE FIELD

regulator printed circuit board (VR<sup>21</sup>).

2. Use a six volt dry cell battery with two clip leads, a 12 amp DC, 300 volt avalanche diode, and a 10-ohm resistor as shown in Figure 8. If a six volt battery is not available, a 12 volt automotive battery can be used by increasing the 10-ohm resistance to 20-ohms; or a 24 volt automotive battery can be used by increasing the resistance to 40-ohms.

**CAUTION** A series resistor **MUST** be used to protect the meter. Polarity must be observed.

3. After starting engine, touch positive (+) battery lead to VR<sup>21-6</sup> and negative (-) lead to VR<sup>21-7</sup>, contact terminals just long enough until voltage starts to build up or damage may occur to exciter-regulator system.

**WARNING** Be cautious when working on a generator that is running to avoid electrical shocks.

## TEST PROCEDURES

All of the following tests can be performed without disassembly of the generator as shown in the illustrations herein. Use the following test procedures for testing generator components in conjunction with the troubleshooting tables.

## [F]

### TESTING ROTATING RECTIFIERS

Two different rectifier assemblies make up the rotating rectifier bridge assembly, Figure 9. Using an accurate ohmmeter, test each CR using negative and positive polarities. Test rectifiers as follows:

1. Disconnect all leads from assembly to be tested.
2. Connect one test lead to F<sup>1+</sup> stud and connect

- other lead to CR<sup>1</sup>, CR<sup>2</sup>, and CR<sup>3</sup> in turn; record resistance value of each rectifier.
3. Connect one lead to F<sup>2-</sup> stud and connect other lead to CR<sup>3</sup>, CR<sup>4</sup> and CR<sup>5</sup> in turn; record resistance value of each rectifier.
4. Reverse ohmmeter leads from step 2 and record resistance value of each rectifier F<sup>1+</sup> to CR<sup>1</sup>, CR<sup>2</sup>, and CR<sup>3</sup> and F<sup>2-</sup> to CR<sup>4</sup>, CR<sup>5</sup>, and CR<sup>6</sup>.
5. All three resistance readings should be high in one test and low in the other test. If any reading is high or low in both tests, rectifier assembly is defective.
6. Replace defective rectifier assembly with new, identical part.

Use 24 lbs-in. torque when replacing nuts on F<sup>1+</sup> and F<sup>2-</sup>, CR<sup>1</sup>, CR<sup>2</sup>, CR<sup>3</sup>, CR<sup>4</sup>, CR<sup>5</sup>, and CR<sup>6</sup>.

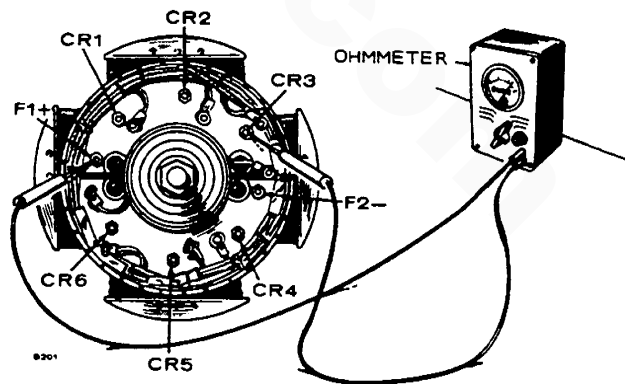

FIGURE 9. TESTING ROTATING RECTIFIERS

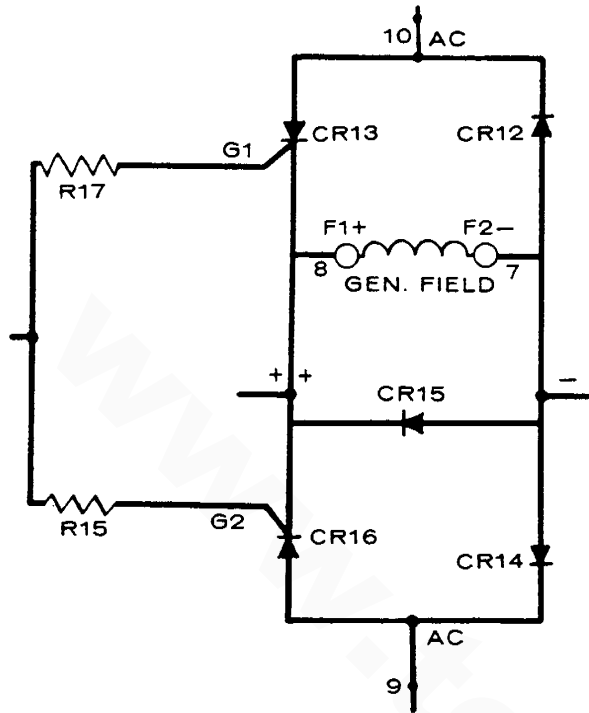

FIGURE 10. SILICON CONTROLLED RECTIFIER BRIDGE

## [G]

### TESTING OUTPUT BRIDGE DIODES

The output bridge rectifier diodes (Figure 10), CR<sup>12</sup>, CR<sup>14</sup>, and CR<sup>15</sup>, are located on the voltage regulator printed circuit board. Using an accurate ohmmeter, test diodes CR<sup>12</sup>, CR<sup>14</sup>, and CR<sup>15</sup> as follows:

1. Disconnect at least one lead of diode.
2. Connect one lead to each end of diode and observe resistance reading, Figure 11.
3. Reverse ohmmeter leads and again observe resistance readings.

**A good diode has a higher reading in one direction than the other. If both readings are high, or low, diode is defective.**

4. Replace defective diodes with new, identical parts.

## [H]

### TESTING SCR'S

Two identical silicon controlled rectifiers (SCR'S), CR<sup>13</sup> and CR<sup>16</sup>, control the DC output voltage to the exciter field. These SCR'S are mounted in heat sinks on the voltage regulator and are tested as follows:

1. Unsolder leads from CR<sup>13</sup> and CR<sup>16</sup>.
2. Using high scale on ohmmeter, connect ohmmeter leads to anode and cathode of the SCR

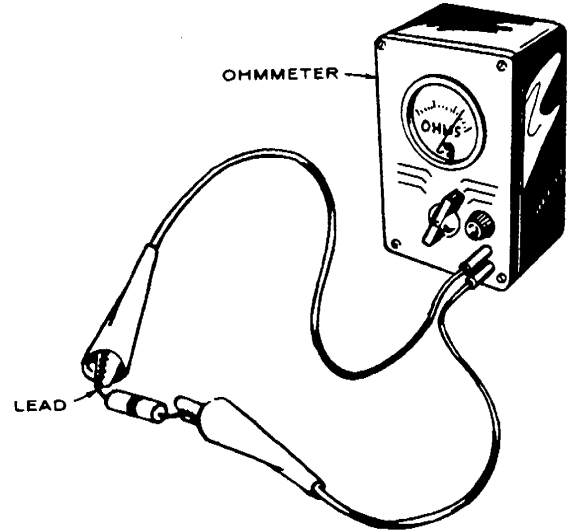

FIGURE 11. TESTING DIODES

as shown in Figure 12. The resistance reading should be one megohm or greater. Reverse ohmmeter leads to anode and cathode; resistance should again be one megohm or greater.

3. Using a 6-volt dry cell battery and a 200-ohm series resistor, observe correct polarity and connect battery leads to anode and cathode as shown in Figure 13. Observe polarity and connect a DC voltmeter across the 200 ohm resistor. The voltmeter should now read zero. Jumper anode to gate; voltmeter should now read 6-volts. Remove jumper; voltmeter should still read 6-volts because the SCR remains turned on until voltage is removed from anode to cathode.

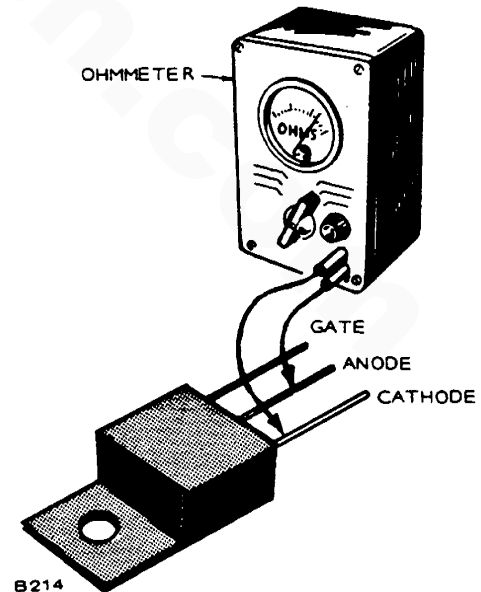

FIGURE 12. SCR RESISTANCE TEST

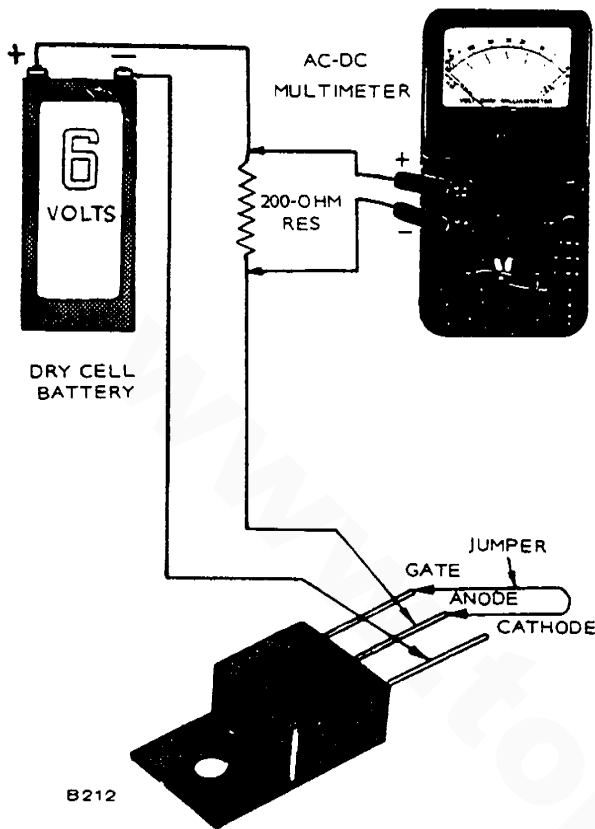

FIGURE 13. SCR VOLTAGE TEST

because the SCR remains turned on until voltage is removed from anode to cathode.

- If the SCR does not pass either test, it is defective. Replace defective SCR with a new, identical part.

## [I]

### TESTING REACTOR

The reactor assembly CMR<sup>21</sup> leads are marked 1, 2, 3 and 4. Wires 1-2 and 3-4 are wound on the same iron core.

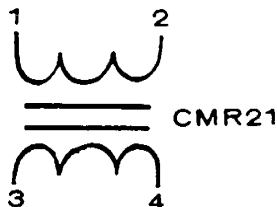

- Resistance between 1-2 and 3-4 should be about 0.4-ohms.
- Resistance between 1-3, 2-3, 1-4, or 2-4 should be infinity (∞).
- Resistance from any terminal to reactor frame should be infinity.
- If any of the above conditions are not met, install a new reactor.

## [J]

### TESTING REFERENCE TRANSFORMER

The transformer T<sup>21</sup> has four leads marked H<sup>1</sup>, H<sup>2</sup>, X<sup>1</sup>, and X<sup>2</sup>. H<sup>1</sup>-H<sup>2</sup> are the primary leads. X<sup>1</sup>-X<sup>2</sup> are the secondary leads.

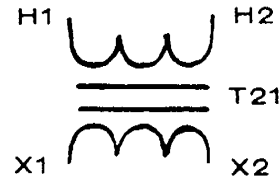

- Resistance between H<sup>1</sup>-H<sup>2</sup> should be 122 to 150-ohms.
- Resistance between X<sup>1</sup>-X<sup>2</sup> should be 157 to 192-ohms.
- Resistance between H<sup>1</sup>-X<sup>1</sup>, H<sup>1</sup>-X<sup>2</sup>, H<sup>2</sup>-X<sup>1</sup> and H<sup>2</sup>-X<sup>2</sup> should be infinity.
- Resistance from any terminal to transformer frame should be infinity.
- If any of the above conditions are not met, install a new reference transformer.

## [K]

### TESTING BRUSHLESS EXCITER STATOR

Like the generator, the brushless exciter stator (Figure 14) can be tested for open or shorted windings and grounds.

#### Testing for Open or Shorted Windings:

Disconnect F<sup>1+</sup> and F<sup>2-</sup> exciter field leads from terminal block in generator end bell. The resistance between field leads should be 12.2 ± 10% at 20 C (68 F.).

#### Testing for Grounds:

Connect ohmmeter between either field lead and exciter stator laminations. Use ohmmeter set at RX 100 scale. An ohmmeter reading of less than infinity (∞) indicates defective ground insulation.



OHMMETER RESISTANCE BETWEEN F1 AND F2 SHOULD BE 12.2 OHMS (± 10%)

FIGURE 14. TESTING EXCITER FIELD

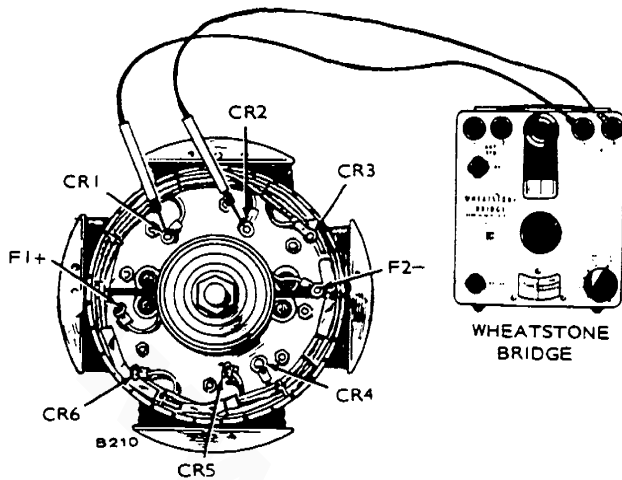

FIGURE 15. TESTING EXCITER ARMATURE

[L]

**TESTING BRUSHLESS EXCITER ROTOR (ARMATURE)**

The brushless exciter rotor (Figure 15), can be tested for open or shorted windings or grounds.

**Testing for Open or Shorted Windings:**

Use a Wheatstone Bridge for this test. Disconnect main rotor field leads which connect to rotating rectifier assemblies at F1+ and F2-. Disconnect lead wires from diodes CR1, CR2, CR3, CR4, CR5 and CR6. Test between exciter lead pairs T1-T2, T2-T3 and T1-T3. Resistance should be 0.5 to 0.6 ohms at 20 C (68 F.).

**Testing for Grounds:**

Connect leads of ohmmeter between each CR lead and exciter rotor laminations; use RX 100 scale on ohmmeter. An ohmmeter reading less than infinity (∞) indicates defective ground insulation.

[M]

**TESTING GENERATOR ROTOR**

For these tests, use an ohmmeter on RX 100 scale.

**Testing for Grounds:**

On brushless type generators, check for grounds between each rotor lead and the rotor shaft, Figure 16. Perform tests as follows:

1. Remove rotor leads F1+ and F2- from rotating rectifier assemblies.
2. Connect ohmmeter leads between F1+ and rotor shaft and between F2- and rotor shaft. Meter should not register.
3. If meter registers, rotor is grounded.

4. Replace grounded rotor with new, identical part.

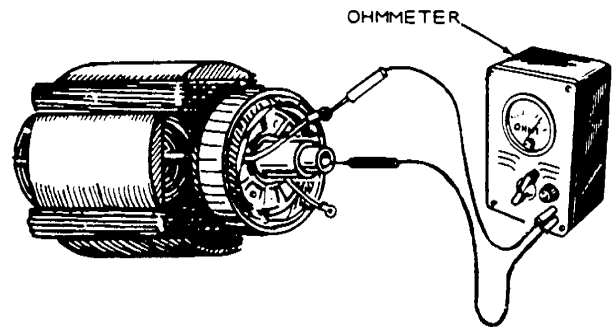

CONTACT ONE PROD TO EACH OF THE FIELD LEADS AND OTHER PROD TO ROTOR SHAFT. IF ROTOR IS GOOD, THERE WILL BE NO READING ON OHMMETER.  
B215

FIGURE 16. TESTING ROTOR FOR GROUNDS

**Testing for Open or Shorted Winding:**

All resistance values should be within ± 10% of values specified in Table 2 at 20°C. (68°F). Perform tests as follows:

1. Remove rotor leads F1+ and F2- from rotating rectifier assemblies.
2. Using ohmmeter, check resistance between F1 and F2 leads, Figure 17. See Table 2 for proper resistance values.

If resistance is low, there are shorted turns. If resistance is high, rotor winding is open. In either case, rotor must be replaced.

3. Replace defective rotor with new, identical part.

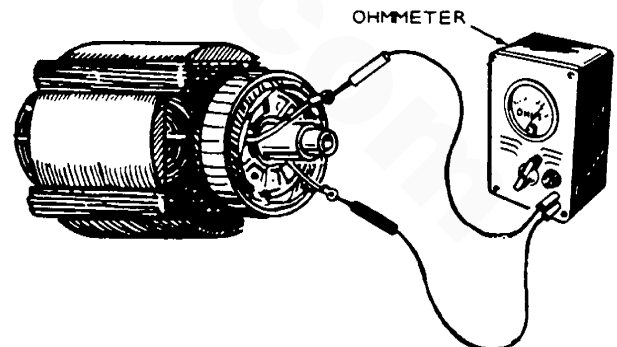

CONTACT ONE PROD TO ONE FIELD LEAD AND OTHER PROD TO OTHER FIELD LEAD. RESISTANCE VALUES ARE GIVEN IN TABLE 2.  
B213

FIGURE 17. TESTING ROTOR FOR AN OPEN CIRCUIT

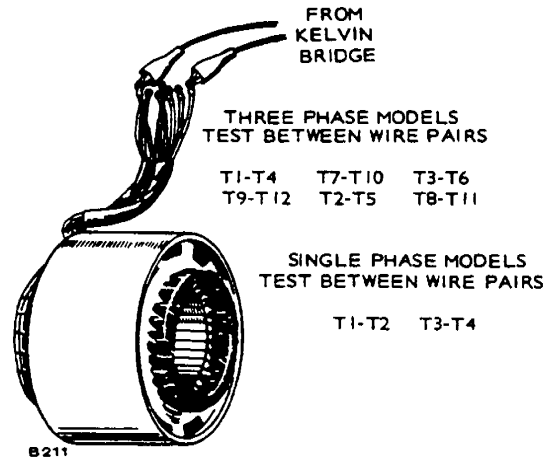

**TABLE 2. RESISTANCE VALUES FOR ROTORS**

Resistance in Ohms at 25C (77F)

10 KW 60 HZ 2.05-2.09

15 KW 60 HZ 2.50-2.55



**FIGURE 18. TESTING STATOR WINDINGS**

**[N]**

**TESTING GENERATOR STATOR**

Using proper test equipment, check the stator for grounds, opens, and shorts in the windings.

**Testing for Grounds:**

Some generators have ground connections to the frame. Check wiring diagram.

Using an ohmmeter set at RX 100, test each stator winding for shorts to laminations. A reading less than one megohm indicates a ground.

**Testing for Open or Shorted Windings:**

Test for continuity between coil leads shown in Figure 18; all pairs should have equal resistance. Use an

accurate instrument for this test such as a Kelvin Bridge. The proper resistance values are given in Table 3 according to KW ratings and voltage codes. All resistances should be  $\pm 10\%$  of value shown at 20°C. (68°F).

If any windings are shorted, open or grounded, replace the stator assembly. Before replacing the assembly, check the leads for broken wires or insulation.

**[O]**

**WIRING HARNESS CHECK**

Carefully check wiring harnesses as follows:

1. Inspect all wires for breaks, loose connections, and reversed connections. Refer to applicable wiring diagram.

**TABLE 3. RESISTANCE VALUES FOR STATORS**

10 KW	60 HZ	1 PH	.172
10 KW	60 HZ	3 PH	.340
15 KW	60 HZ	1 PH	.087
15 KW	60 HZ	3 PH	.220

2. Remove wires from terminals at each end and using an ohmmeter, check each wire end to end for continuity or opens.
3. Using an ohmmeter, check each wire against each of the other wires for possible shorts or insulation breaks under areas covered by wrapping material.
4. Reconnect or replace wires according to applicable wiring diagram.

## [P]

### VR<sup>21</sup> REPLACEMENT

Use the following procedure for replacing the voltage regulator PC board.

1. Stop engine.
2. Disconnect and if necessary, label the following wires: 3, 4, 5 or 6, 7, 8, 9, and 10.
3. Remove four screws at corners.
4. Remove used PC board.
5. Install new PC board; secure with four screws.
6. Reconnect wires removed in step 2 at the proper terminals.
7. Place jumper W10 at proper terminals for your particular voltage code and voltage connection. See Figure 6.
8. Perform voltage calibration and stability adjustment procedures to obtain the correct generator output voltage and stability with new PC board in set.

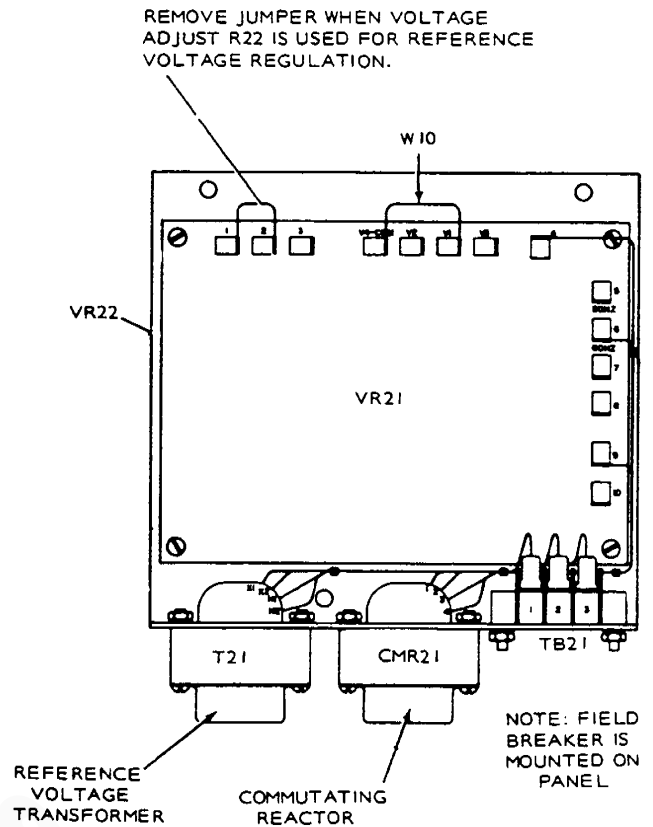

## GENERATOR DISASSEMBLY

Disconnect battery to prevent accidental starting of engine.

Remove end bell cover to reveal rotor-through-stud nut.

Remove stator-through-stud nuts, end bell, and stator assembly, Figure 20. Screwdriver slots in adapter provide a means for prying stator loose. Be careful not to let stator touch or drag on rotor.

Remove baffle ring from adapter. Turn rotor-through-stud nut to end of stud. While pulling rotor outward with one hand, strike nut a sharp blow. Support rotor with hoist and sling to avoid bending rotor-through-stud, Figure 21. Use a heavy, soft faced hammer to loosen the rotor from its tapered shaft fit. If rotor does not come loose, strike it a sharp downward blow in center of lamination stack. Rotate rotor and repeat until it comes loose. Be careful not to hit bearing or windings.

After disassembly, all parts should be wiped clean and visually inspected.

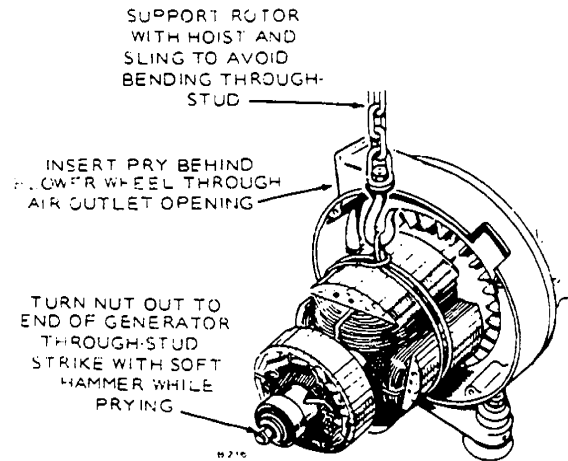

FIGURE 21. ROTOR REMOVAL

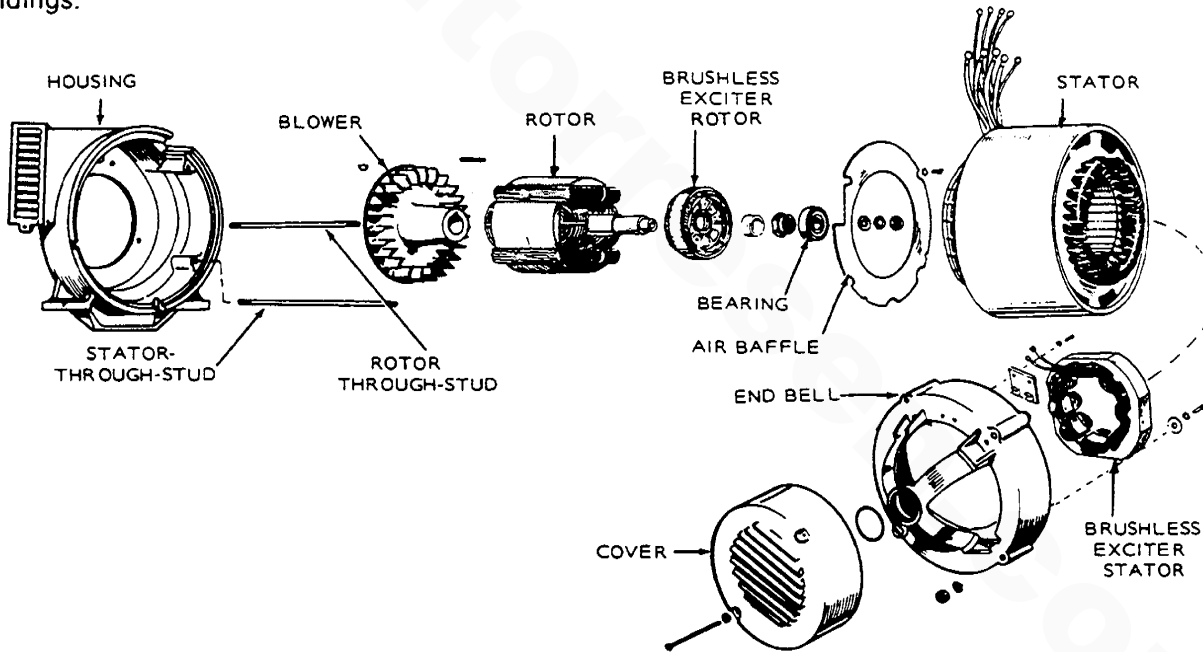

FIGURE 20. GENERATOR DISASSEMBLY

### GENERATOR ASSEMBLY

Clean and inspect all mating surfaces.

Coat mating area between generator bearing and end bell bearing hole with a thin film of Molykote or equal.

Install rotor-through-stud in engine crankshaft.

Install key in the crankshaft.

Slide rotor over through-stud and onto crankshaft. Be careful not to let weight of rotor rest on or bend the through-stud.

Install baffle ring.

Install stator through-studs in adapter.

Install stator and end bell. Torque nuts on through-studs to 35 to 38 ft-lbs.

Torque down rotor-through-stud nut (55-60 ft. lb.). The rotor and stator are automatically aligned because stator and bearing support were tightened in step 8.

Tap end bell to align at horizontal and vertical plane; use a lead hammer to relieve stresses in components (recheck torque).

Install end cover.

# GENERATOR TROUBLESHOOTING

## PREPARATION

A few simple checks and a proper troubleshooting procedure can locate the probable source of trouble and cut down troubleshooting time.

1. Check all modifications, repairs, replacements performed since last satisfactory operation of set to be sure that connection of generator leads are correct. A loose wire connection, overlooked when installing a replacement part could cause problems. An incorrect connection, an opened circuit breaker, or a loose plug-in printed circuit board are all potential malfunction areas to be eliminated by a visual check.
2. Unless absolutely sure that panel instruments are accurate, use portable test meters for troubleshooting.
3. Visually inspect components on VR<sup>21</sup>. Look for dirt, dust, or moisture and cracks in the printed solder conductors. Burned resistors, arcing tracks are all identifiable. Do not mark on printed circuit boards with a pencil. Graphite lines are conductive and can cause short circuits between components.

The question and answer troubleshooting guide which follows, gives a step-by-step procedure for checking the generator components. Refer to Figure 22 for an electrical schematic of the generator and voltage regulator connections.

## TROUBLESHOOTING PROCEDURES

This troubleshooting information is divided into tables, A, B, C, and D as follows:

- A. No build up of AC output voltage.
- B. AC output voltage builds up, but is unstable.
- C. AC output voltage builds up, but is high or low.

D. AC output voltage builds up, but field breaker trips.

To correct a problem, answer the question of the step either YES or NO. Then refer to the step number in the answer column and proceed to that step next.

Letters A through P in the Test Procedure column refer to detailed procedures in the Adjustments and Tests section,

TABLE A. No Build Up of AC Output Voltage	Yes	No	Test Proc.
1. Is Field Breaker CB21 on control panel ON?	2	3	
2. Connect jumper wire across terminals of Field Breaker, CB21. Does AC output voltage build up? If voltage builds up REPLACE FIELD BREAKER.	—	4	
3. Push to reset Field Breaker. Does AC output voltage build up? If voltage builds up but is high, low, unstable, or causes tripping of Field Breaker, refer to Tables B, C, or D.	—	4	
4. Disconnect alternator stator leads 1 & 2 from TB21-1 and TB21-2 on VR22. Is reference voltage across 1 & 2 20 VAC or more?	14	13	

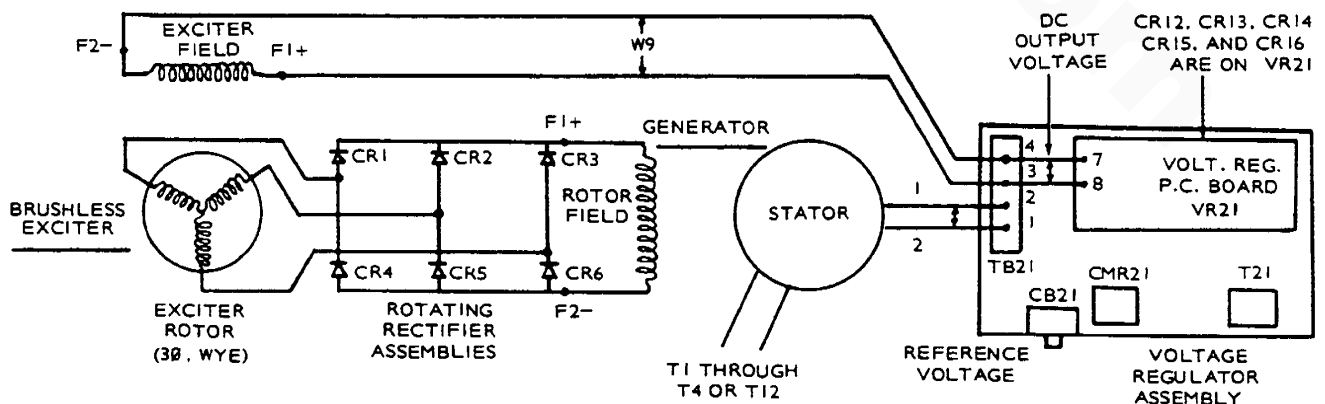

FIGURE 22. GENERATOR-REGULATOR ELECTRICAL SCHEMATIC

TABLE A. (continued)	Yes	No	Test Proc.
5. Is exciter field voltage across F1+ and F2- on endbell terminal block 7.0 VDC or more? If not, check wiring harness W9 from end bell to VR22 terminals 3 and 4.	6	—	
6. Is brushless exciter stator (field) winding OK?	7	—	K
7. Are diodes CR1, CR2, CR3, CR4, CR5, CR6 in rotating rectifier assemblies OK? Check all diodes - more than one may be defective.	8	—	F
8. Are brushless exciter rotor windings OK?	9	—	L
9. Is generator rotor field winding OK?	10	—	M
10. Are generator stator windings OK?	11	—	N
11. Is commutating reactor CMR21 OK?	12	—	I
12. Is reference transformer T21 OK?	18	—	J
13. Flash exciter field. Is reference voltage across 1 and 2 now 20 VAC or more?	14	5	E
14. Reconnect generator leads 1 & 2 to TB21-1 and TB21-2 on VR22. Does reference voltage build up?	—	15	
15. Is regulator DC output voltage across VR21-7 and VR21-8 7 VDC or more? See Figure 22.	5	16	
16. Are SCR's CR13 and CR16 OK?	17	—	H
17. Are diodes CR12, CR14, and CR15 OK?	18	—	G
18. Replace voltage regulator PC board (VR21)	—	—	P

TABLE B. AC Output Voltage Builds Up, But Is Unstable	Yes	No	Test Proc.
1. Are there any loose or broken wires or connections on voltage regulator assembly VR22?	—	2	
2. Is W9 (exciter field) wiring harness from VR22 to End bell OK?	3	—	
3. Does adjustment of Damping Control R27 potentiometer on VR21 result in stable voltage?	—	4	A
4. Replace PC Board VR21.	—	—	P

**CAUTION** Do not replace the printed circuit board until the trouble not on the PC board has been located and corrected to avoid damage to new PC board.

TABLE C. AC Output Voltage Builds Up, But is High or Low	Yes	No	Test Proc.
1. Is set running at correct RPM? (See appropriate engine manual to set RPM)	2	—	
2. Does adjustment of Voltage Adjusting knob for R22 on VR22 result in correct output voltage?	—	3	A
3. Does adjustment of potentiometer R26 on VR21 result in correct output voltage?	—	4	A
4. Is correct voltage reference V4 to V1, V2, or V3 on VR21 being used? Refer to Figure 6.	5	—	
5. Are generator output leads properly connected? Refer to Figure 6.	6	—	
6. Replace voltage regulator, PC board VR21	—	—	P

**CAUTION** Do not replace the printed circuit board until the trouble not on the PC board has been located and corrected to avoid damage to new PC board.

TABLE D. AC Output Voltage Builds Up, But Field Breaker Trips	Yes	No	Test Proc.
1. Does AC output voltage build up to 140% or more of rated voltage before Field Breaker trips?	2	7	—
2. Are there any loose or broken wires or connections on VR22?	—	3	
3. Is diode CR15 on VR21 OK?	4	—	G
4. Are T21 windings and connections OK?	5	—	J
5. Are generator stator leads properly connected? Refer to Figure 6.	6	—	—
6. Replace VR21.	—	—	P
7. Are diodes CR1, CR2, CR3, CR4, CR5, CR6 in rotating rectifier assemblies OK? Check all diodes - more than one may be defective.	8	—	F
8. Is brushless exciter stator winding OK?	9	—	K
9. Is generator rotor field winding OK?	10	—	M
10. Is brushless exciter rotor OK?	11	—	L
11. Are generator stator windings OK?	6	—	N

**ADJUSTMENTS AND TESTS — REFERENCE LIST**

- A. VOLTAGE CALIBRATION ADJUSTMENT
- B. VOLTAGE STABILITY ADJUSTMENT
- C. BATTERY CHARGE RATE ADJUSTMENT
- D. VOLTAGE REGULATOR CHECKOUT
- E. FLASHING THE FIELD
- F. TESTING ROTATING RECTIFIERS
- G. TESTING OUTPUT BRIDGE DIODES
- H. TESTING SCR'S
- I. TESTING REACTOR
- J. TESTING REFERENCE TRANSFORMER
- K. TESTING EXCITER STATOR
- L. TESTING BRUSHLESS EXCITER ROTOR (ARMATURE)
- M. TESTING GENERATOR ROTOR
- N. TESTING GENERATOR STATOR
- O. WIRING HARNESS CHECK
- P. VR21 REPLACEMENT

## YOUR NOTES

[www.torresen.com](http://www.torresen.com)

## SECTION V

# SERVICE BULLETINS

The following Bulletins contain supplementary and updated information about various components and service procedures which are important to the proper functioning of your engine and its support systems.

You should familiarize yourself with the subjects and make sure that you consult the appropriate Bulletin(s) whenever your engine requires service or overhaul.



# SERVICE BULLETIN

DATE: 6/15/69

BULLETIN NUMBER: 20

MODEL: All Engines

SUBJECT: Connecting Pressure Sensing Devices to Oil Galleries

Oil pressure sensing devices, such as senders and switches, must never be connected directly to any oil gallery of an engine. The reason is simply that continued engine vibration causes fatigue of the fittings used to make such a connection. If these fittings fail, the engine loses its oil pressure and very quickly seizes.

Such pressure sensing devices must be bulkhead mounted and connected to the oil gallery using an appropriate grade of lubricating oil hose. Any fittings used to connect the hose to the gallery must be of steel or malleable iron. Brass must not be used for this purpose.



**J. H. WESTERBEKE CORP.**

AVON INDUSTRIAL PARK, AVON, MASS. 02322 · (617) 598-7700  
CABLE: WESTCORP, AVON · TELEX: 92-4444

P/N: 11967

# SERVICE BULLETIN

V.3

DATE: 5/6/74

BULLETIN NUMBER: 69

MODEL: All marine generators and marine engines

SUBJECT: Exhaust system failures

When engine sea water is fed into an exhaust system so that the full stream strikes a surface, erosion may cause premature failures.

Proper design of either a water jacketed or a water injected ("wet") exhaust system to prevent this problem requires that the sea water inlet be positioned so that the entering stream of sea water does not strike a surface directly. Also, the velocity of the entering sea water stream should be as low as possible which is achieved by having inlet fittings as big in diameter as possible.

In addition to the above design considerations, it is usually advantageous to divide the sea water flow at the point of entry to the exhaust system so that only a portion of it enters the exhaust system. The remainder is normally piped directly over the side. The proper proportion of the sea water flow to pass through the exhaust system can only be determined by trial and error. The goal is to prevent excessive exhaust temperatures with the least amount of sea water.



**J. H. WESTERBEKE CORP.**

AVON INDUSTRIAL PARK, AVON, MASS. 02322 (617) 588-7700  
CABLE: WESTCORP, AVON-TELEX: 92-4444

V.4

# SERVICE BULLETIN

DATE: May 19, 1980

BULLETIN NUMBER: 82

MODEL: A11

SUBJECT: Battery Recommendations

## BATTERY RECOMMENDATIONS

<u>MODEL</u>	<u>BATTERY AMPERE HOURS</u>	<u>VOLTAGE</u>
W-7, & WPD4	60-90	12 V.D.C.
W-13 & 4.4 KW	90-125	12 V.D.C.
W-21 & 7.7 KW	90-125	12 V.D.C.
W-27 & 11 KW	90-125	12 V.D.C.
W-33	90-125	12 V.D.C.
W-30	125-150	12 V.D.C.
W-40, & WPD-10-15 KW	125-150	12 V.D.C.
W-50	125-150	12 V.D.C.
W-58 & WTO-20 KW	125-150	12 V.D.C.
W-60 & WBO-20 KW	150-170	12 V.D.C.
W-80 & 30KW	170-200	12 V.D.C.
W-120 & 45 KW	200 minimum	12 V.D.C.

The ampere hour range shown is minimum. There is no real maximum.



**J. H. WESTERBEKE CORP.**

AVON INDUSTRIAL PARK, AVON, MASS. 02322 · (617) 588-7700  
CABLE: WESTCORP, AVON · TELEX: 92-4444

# SERVICE BULLETIN

DATE: April 4, 1983

BULLETIN NUMBER: 87

MODEL: All Marine Engines

SUBJECT: Alternator Output Splitter

GENERAL DESCRIPTION: The splitter is a solid state device which allows two batteries to be recharged and brought to the same ultimate voltage from a single alternator as large as 120 amp and, at the same time, isolates each battery so that discharging one will have no effect on the other. Charging rates are in proportion to the batteries' voltage (state of discharge.) This method precludes the necessity, and even the desirability, of a rotary switch for selecting which battery is to be charged. It also assures that ships services cannot drain the engine starting battery.

INSTALLATION:

1. Mount splitter on metal surface other than the engine, preferably in an air stream if available. Do not install near engine exhaust system. Install with cooling fins aligned vertically.
2. Be sure to use a wire size appropriate to the output of the associated alternator. In full power systems number 4 wire is recommended from the alternator to the splitter and from the splitter to the batteries.
3. Connect the alternator output terminal to the center splitter terminal.
4. Connect one splitter side terminal to one battery (s).
5. Connect the other splitter side terminal to the other battery(s).
6. When the splitter is installed, both batteries will see a charging voltage 8/10 volts less than usual. This voltage drop can be regained, if desired, by connecting the regulator wire directly to the alternator output terminal instead of the regulator terminal.

TEST INFORMATION: When the engine is not running, the side splitter terminals should read the voltage of the respective battery. The center splitter should read zero voltage.

With the engine running and alternator charging, the side splitter terminals should read the same voltage which should be the voltage of the regulator or somewhat less. The center splitter terminal should read .82 volts higher than the readings of the side terminals.

Continued.....



**J. H. WESTERBEKE CORP.**

AVON INDUSTRIAL PARK, AVON, MASS. 02322 · (617) 588-7700  
CABLE: WESTCORP, AVON · TELEX: 92-4444

P/N:

This unit is sealed for maximum life and is not repairable.

BY-PASSING SPLITTER; In the event of failure, batteries may be charged directly from alternator by connecting either splitter terminal #1 or #2 to terminal A, bypassing the splitter itself. This should not be done simultaneously for both batteries unless they are, and will remain at, the same voltage (state of charge.)

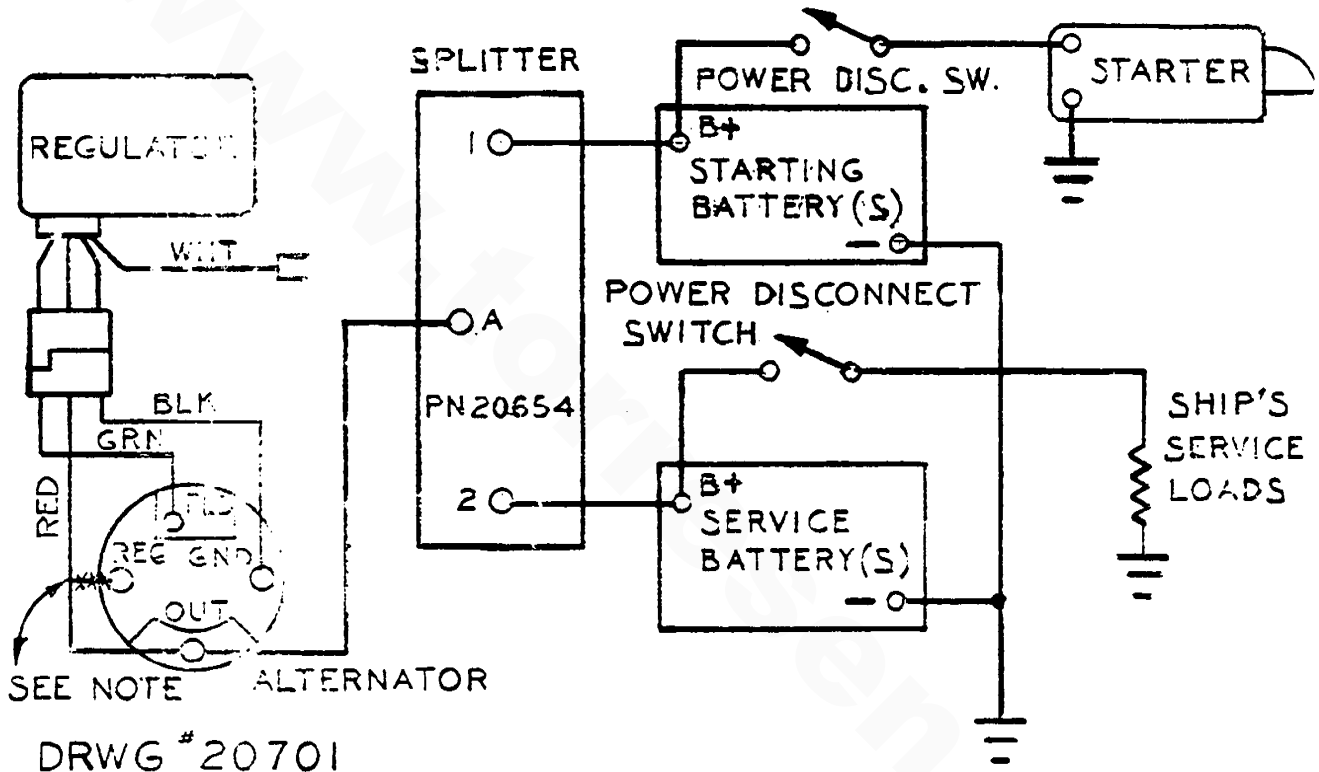

NOTE: On Alternators which have an isolation diode between their output and regulator terminals, such as the Motorola units used with most WESTERBEKE engines, the regulator wire should be removed from the REG terminal and reconnected to the OUTPUT terminal as shown. The diode in the splitter will provide an equivalent voltage drop.

# SERVICE BULLETIN

DATE: April 28, 1976

BULLETIN NUMBER: 92

MODEL: A11

SUBJECT: Troubleshooting Water Temperature and Oil Pressure Gauges

Given a presumably faulty gauge indication with the instrument panel energized, the first step is to check for 12 VDC between the ign. (B+) and neg. (B-) terminals of the gauge.

Assuming there is 12 volts as required, leave the instrument panel energized and perform the following steps:

1. Disconnect the sender wire at the gauge and see if the gauge reads zero, the normal reading for this situation.
2. Connect the sender terminal at the gauge to ground and see if the gauge reads full scale, the normal reading for this situation.

If both of the above gauge tests are positive, the gauge is undoubtedly O.K. and the problem lies either with the conductor from the sender to the gauge, or with the sender.

If either of the above gauge tests is negative, the gauge is probably defective and should be replaced.

Assuming the gauge is O.K., proceed as follows. Check the conductor from the sender to the sender terminal at the gauge for continuity.

Check that the engine block is connected to ground. Some starters have isolated ground terminals and if the battery is connected to the starter (both plus and minus) the ground side will not necessarily be connected to the block.

If the sender to gauge conductor is O.K. and the engine block is grounded, the sender is probably defective and should be replaced.



**J. H. WESTERBEKE CORP.**

AVON INDUSTRIAL PARK, AVON, MASS. 02322 • (617) 588-7700  
CABLE: WESTCORP, AVON • TELEX: 92-4444

P/N: 21616

# SERVICE BULLETIN

DATE: 7 July 80 Reissued

BULLETIN NUMBER: 95

MODEL: A11

SUBJECT: Domestic Hot Water Heaters

## Principle

The heater is connected in series with the engine's freshwater circuit. This allows full water flow for maximum heat transfer to the heater. The series installation also avoids several potential pitfalls of installations in which the heater is in parallel with either the engine's by-pass or its internal freshwater circuit.

The only potential disadvantage of a series installation is flow restriction due either to a restrictive heater design, a large engine water flow (such as models W58, W80, W120), or a combination of both.

## Installation

The shorter the length of piping to and from the heater, the better. The elevation of the heater should assure that the top of its internal coil is no higher than the engine pressure cap. If the heater must be higher than this at any heel angle, then the optional remote fill tank must be installed to be the highest point of the circuit.

Piping between the engine and heater should rise continuously from the heater to the engine so that trapped air will rise automatically from the heater to the engine. If trapped air can rise to the heater, then a petcock or other convenient method of bleeding that air is a necessity.

Study the attached sketches. A convenient place to interrupt the engine cooling circuit is between the thermostat housing outlet and the exhaust manifold inlet. This is also the hottest water available. CAUTION: While most owners want the hottest water available, it is possible for scalding water or even steam to come from the faucets.

Since the heater is in series with the engine cooling water, any other convenient point of the circuit can also be interrupted for heater installation.

Some engine/heater combinations require that a "by-pass" nipple be installed in parallel with the heater. This is required to maintain an adequate fresh water flow for cooling capability. The table below shows the minimum diameter of "by-pass" nipples in these situations:

MODEL	SENDURE	ALLCRAFT	RARITAN	HEATER			
				MODEL	SENDURE	ALLCRAFT	RARITAN
W13	None	None	None	W50	None	None	1/2" NPT
W21	None	None	None	W52	None	None	1/2" NPT
W27	None	None	None	W58	1/2" NPT	1/2" NPT	3/4" NPT
W33	None	None	3/8" NPT	W80	1/2" NPT	1/2" NPT	3/4" NPT
W30	None	None	3/8" NPT	W120	1/2" NPT	1/2" NPT	3/4" NPT
W40	None	None	3/8" NPT				

Please see sketches on reverse.



**J. H. WESTERBEKE CORP.**

AVON INDUSTRIAL PARK, AVON, MASS. 02322 · (617) 588-7700  
 CABLE: WESTCORP, AVON · TELEX: 92-4444

P/N: 21814

SKETCH A

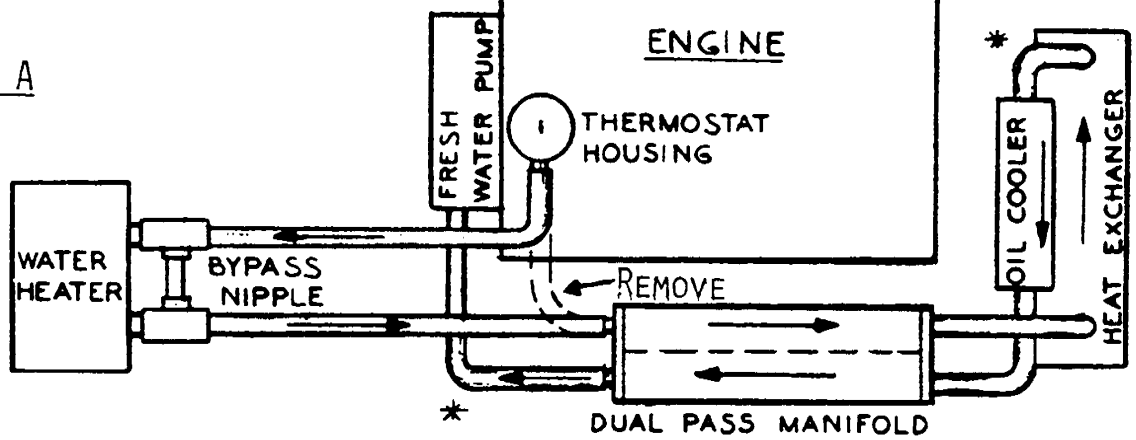

\* ALTERNATE PLACES TO INTERRUPT CIRCUIT AND CONNECT HEATER IN SERIES.

SKETCH B

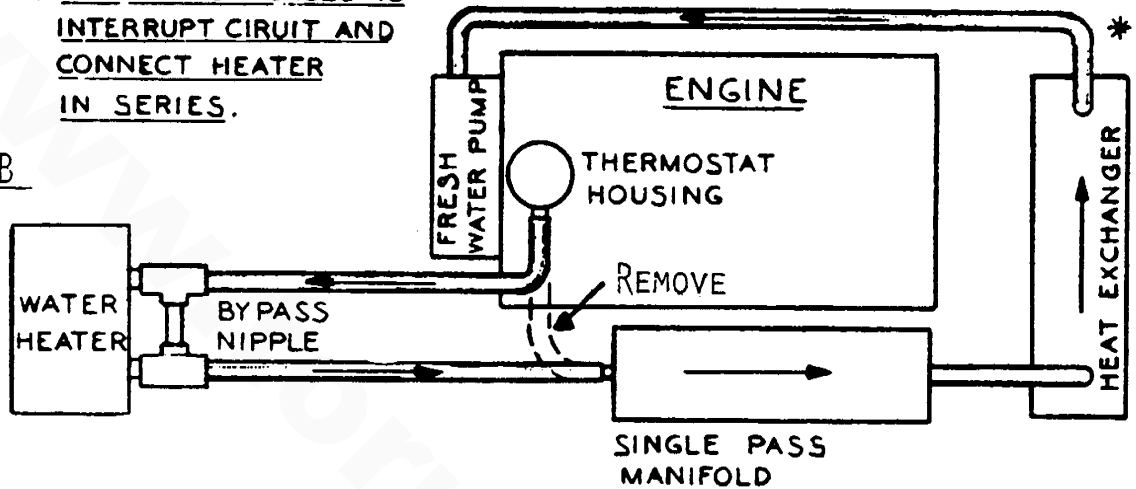

SKETCH C

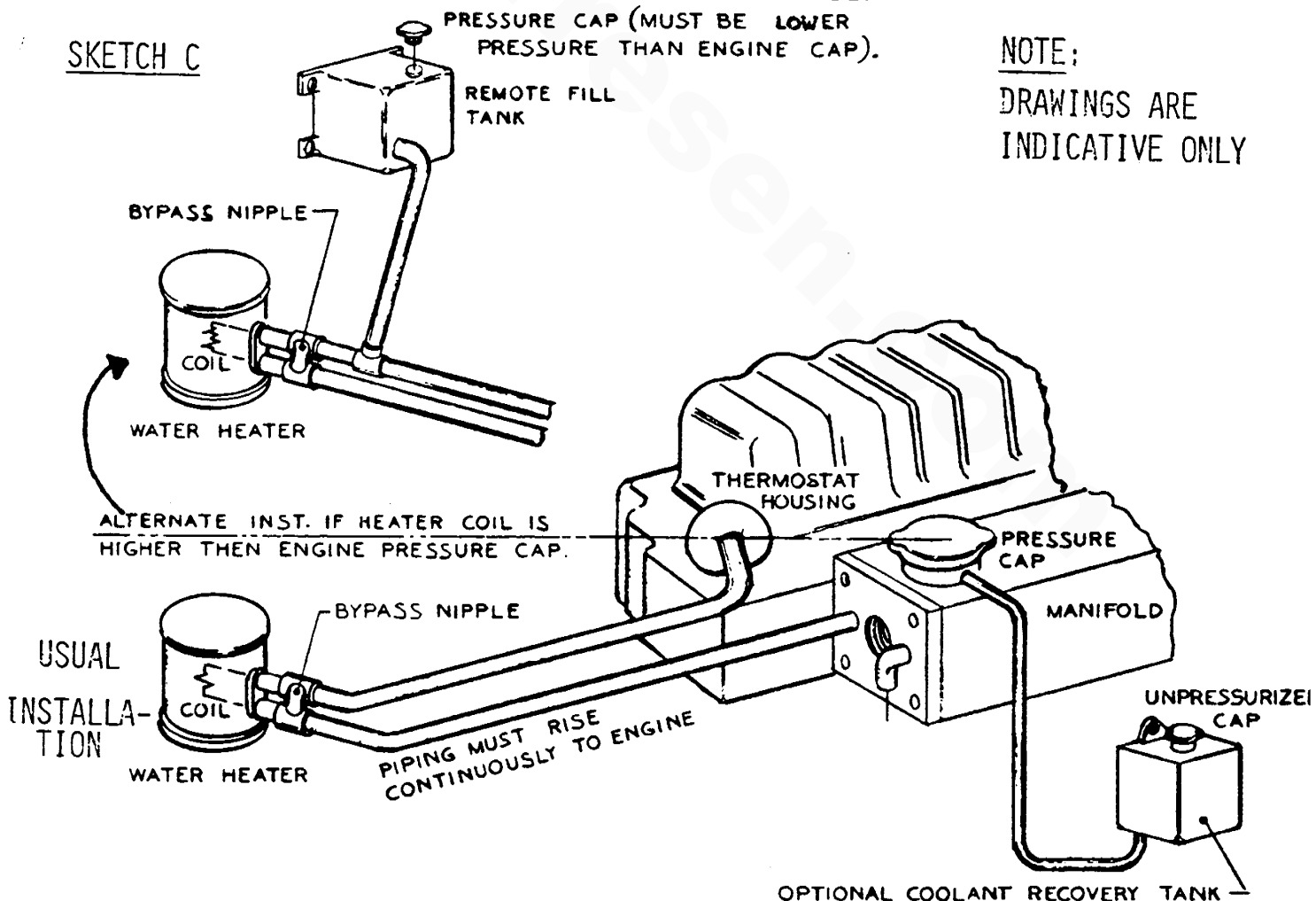

NOTE:  
DRAWINGS ARE  
INDICATIVE ONLY



# SERVICE BULLETIN

DATE: January 22, 1980

BULLETIN NUMBER: 104

MODEL: W30, W50, W58

SUBJECT: Sea Water Pump Pulley Set Screw P.N. 11357

The sea water pump pulley on the Westerbeke 30 and 50 engines is keyed to the sea water pump shaft and locked in position with a heat treated 5/32" Allen head set screw, Westerbeke P.N. 11357.

Particular attention should be paid to this set screw at the time of commissioning of the engine and during regular servicing of the engine. Ensure that it is tight. If not, remove the set screw and apply a good locking liquid to the set screw threads and reinstall and tighten with the aid of a 5/32" Allen wrench.

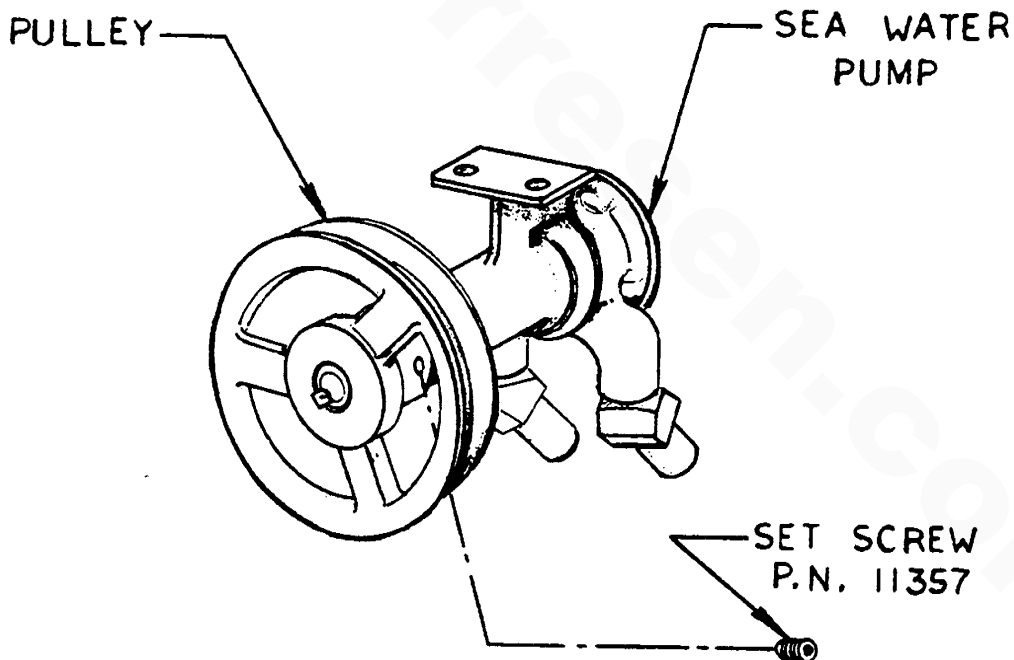

**J. H. WESTERBEKE CORP.**

AVON INDUSTRIAL PARK, AVON, MASS. 02322 - (617) 588-7700  
CABLE: WESTCORP, AVON - TELEX: 92-4444

P/N: 24293

# SERVICE BULLETIN

**DATE:** May 20, 1980  
**MODEL:** A11  
**SUBJECT:** Ammeter Wire Sizes

**BULLETIN NUMBER:** 110

Ammeters may be installed in conjunction with any Westerbeke marine diesel engine or diesel generator set. The range of the ammeter must be appropriate for the maximum output of the alternator.

Additionally, the wire size for the alternator output circuit, including the ammeter, varies with the total length of that circuit. The table below shows the maximum current that can be carried various total distances by various wire sizes, to and from source to load.

WIRE SIZE TABLE

System Volts	Total Length of wire in feet	MAXIMUM CURRENT (AMPS)						
		35	40	55	60	70	85	120
12	1 to 5	12	12	12	8	8	8	6
12	5 to 10	10	10	8	6	6	6	4
12	10 to 20	6	6	6	6	3	2	1
12	20 to 30	6	4	4	2	1	1	1
12	30 to 40	4	2	2	1	1	0	0
24	1 to 5	14	14	12	12	10	10	8
24	5 to 10	12	12	10	10	8	8	6
24	10 to 20	10	8	8	6	6	4	4
24	20 to 30	8	6	6	4	4	4	2
24	30 to 40	6	6	4	4	2	2	0
32	1 to 5	14	14	12	12	10	10	8
32	5 to 10	12	12	10	10	8	8	6
32	10 to 20	10	8	8	6	6	4	4
32	20 to 30	8	6	6	4	4	4	2
32	30 to 40	6	6	4	4	2	2	0



**J. H. WESTERBEKE CORP.**

AVON INDUSTRIAL PARK, AVON, MASS. 02322 · (617) 588-7700  
 CABLE: WESTCORP, AVON · TELEX: 92-4444

P/N: 24737

# SERVICE BULLETIN

**DATE:** May 6, 1982

**BULLETIN NUMBER:** #114

**MODEL:** All Marine Engines

**SUBJECT:** Domestic Water Heater Installation  
Using Westerbeke FLOWCONTROLLER

Principle: There are two 7/8" hose connections at the end of the manifold which provide a parallel flow of engine cooling water to and from the heater. These connections are part of the FLOWCONTROLLER which assures a flow of hot water through the heater at all times and yet precludes excessive restriction of engine cooling water flow caused by the heater - all simply and automatically.

Installation: Remove the returnbend which normally connects the 7/8" hose spuds on engines as shipped from the factory. Connect these spuds to the heater with 7/8" ID wire inserted hose. The spud marked "out" indicates the flow from the engine and the spud marked "in" indicates the flow returning to the engine.

Hoses should rise continuously from their low point at the heater and to the engine so that trapped air will rise naturally from the heater to the engine. If trapped air can rise to the heater, then an air bleed petcock must be installed at the higher fitting at the heater for bleeding the air while filling the system. Avoid loops in hose runs which will trap air.

If any portion of the engine cooling water circuit to or from the heater rises above the engine's own pressure cap, then the pressurized remote expansion tank must be installed in the circuit to be the highest point. The tank kit Part Number is 24177. Install the remote expansion tank in a convenient location such as a sail locker for ease of checking fresh water coolant level.

The cap on the engine mounted expansion tank/manifold should not be opened once the system is installed and filled.

The hose connection from the heater to the remote expansion tank should be routed and supported so as to rise continuously from the heater to the tank enabling any air in the system to rise.

FLOWCONTROLLER kits are available for retro-fit to late 1980, 1981 and 1982 Westerbeke marine engines which employ the "two-pass" exhaust manifold. The kit numbers are:

Kit #32276 for engines whose exhaust manifold is on the left side of cylinder head (W21, RD60, W27, RD80, W33).

Kit #32274 for W13 and Kit #32275 for W52 and W58 engines whose exhaust manifold is on the right side of the cylinder head.



**J. H. WESTERBEKE CORP.**

AVON INDUSTRIAL PARK, AVON, MASS. 02322 · (617) 588-7700  
CABLE: WESTCORP, AVON · TELEX: 92-4444

P/N: #32277

## HEATER BELOW ENGINE

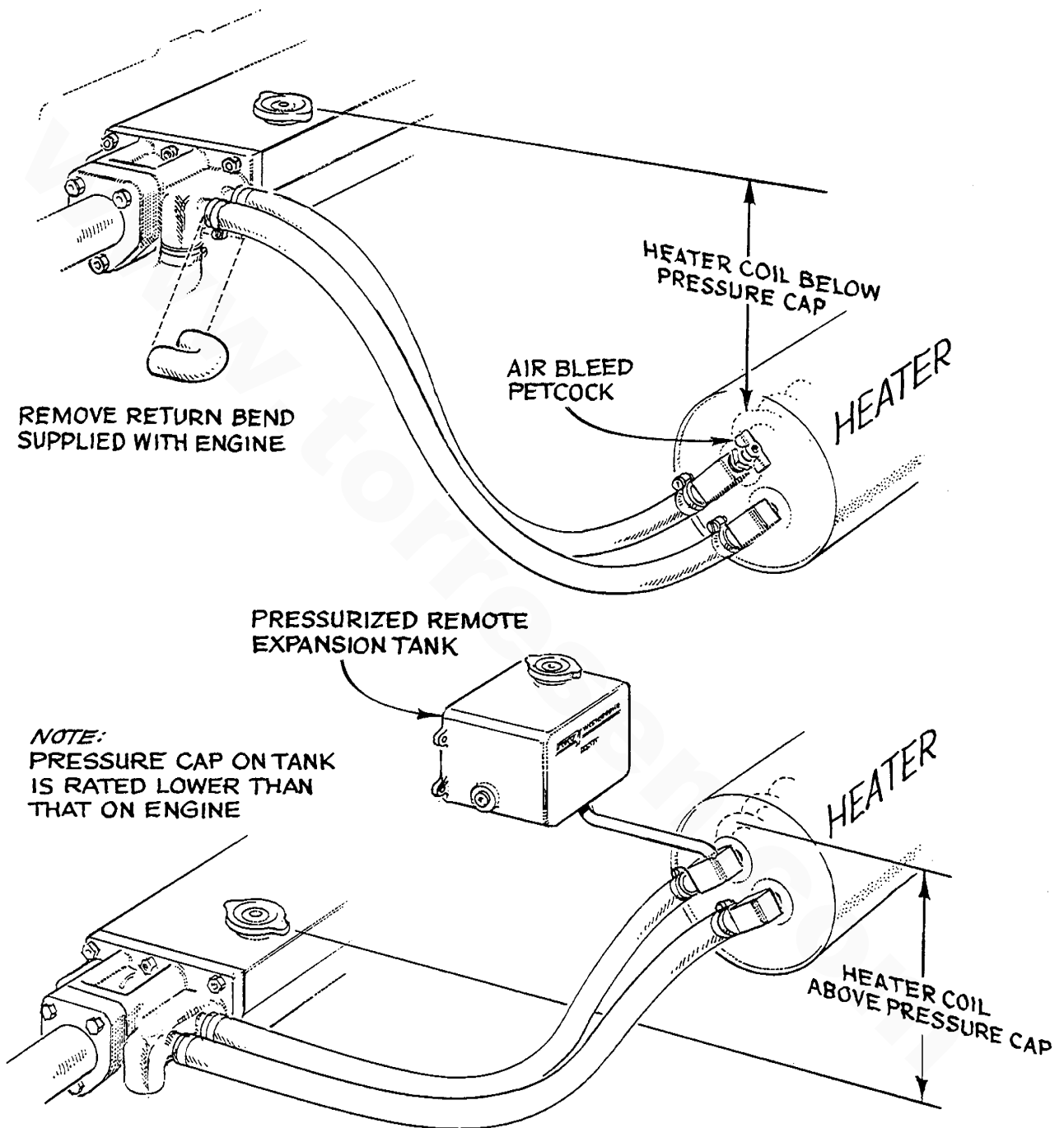

## HEATER ABOVE ENGINE

[www.torresen.com](http://www.torresen.com)

# SERVICE BULLETIN

DATE: March 18,1983

BULLETIN NUMBER: 121

MODEL: All Marine Engines

SUBJECT: Shift Cover Sealing

Shift covers on all HBW-Transmissions are now being mounted on the transmission by the manufacturer with loctite (orange) thus eliminating the use of the shift cover gasket (PN #22207).

This sealant will prevent the shift cover from moving out of its factory adjusted position even after removal of the 4 mounting bolts (PN #22208) and thus allow for the original factory adjusted shift pattern to be maintained.

#### IMPORTANT

Removal or disturbing of the shift cover will void all warranty responsibility by Westerbeke.

Any HBW-Transmission suspect to defect during the warranty period specified by Westerbeke must be returned with the shift cover undisturbed and in its original position. Prior approval must be obtained for all HBW-Transmissions to be removed, repaired or returned (R.G.A.) under warranty.

To: Master Distributors  
Registered Manual List



**J. H. WESTERBEKE CORP.**

AVON INDUSTRIAL PARK, AVON, MASS. 02322 · (617) 588-7700  
CABLE: WESTCORP, AVON · TELEX: 92-4444

P/N: 33074

# SERVICE BULLETIN

DATE: November 16, 1983

BULLETIN NUMBER: 129

MODEL: Models WTA 15, 20, 25KW

SUBJECT: Resistance Values WTA Model Generators

Provided below are resistance values for early and late model WTA generator units:

## SINGLE PHASE ELECTRICAL RESISTANCES FOR MODELS WTA 15, 20, 25KW

MODEL WTA	MAIN STATOR		AUX. COILS			EXC. STATOR		MAIN ROTOR	EXC. ROTOR
	T1-T2	T3-T4	A1-A2	A2-A3	A1-A3	F1-F3	F2-F4		
15 & 20	0.05	0.05	0.15	0.09	0.09	2.0	3.0	3.2*	0.7*
15,20,25	0.04	0.04	0.14	0.08	0.08	2.3	3.4	3.0*	0.8*

(REFER TO FIGURE C GENERATOR SCHEMATIC)

(Values are in Ohms)

### NOTES

\*These values represent measurements taken with leads connected to bridge rectifier. Measurements for main rotor are taken from red dot terminal on rectifier to ground. Exciter measurements can be taken from terminal to terminal, refer to operating manual for rectifier testing.

(1) The above chart is intended for reference use only, as a 10 percent tolerance on these figures is common. Comparison of ratios of actual readings to the above figures is often a more accurate method of troubleshooting.

(2) If any abnormal variations cannot be isolated and symptoms are still evident, contact your Distributor.

(3) Early model WTA 15 & 20KW generator units can be distinguished from later model WTA 15, 20 & 25KW generators when checking resistance values by removing one of the screens from the generator exhaust fan area and visually looking squarely into the generator. On early model WTA 15 & 20KW units, no windings will be visible extending beyond the opening exposed when this screen is removed.

Later model WTA 15, 20 & 25KW units will have about 1/2 - 5/8 inches of windings visible in the opening. Reference the drawing attached. Figure A (early models 15 & 20KW). Figure B (later models 15, 20 & 25KW).



**J. H. WESTERBEKE CORP.**

AVON INDUSTRIAL PARK, AVON, MASS. 02322 · (617) 588-7700  
 CABLE: WESTCORP, AVON · TELEX: 92-4444

33544

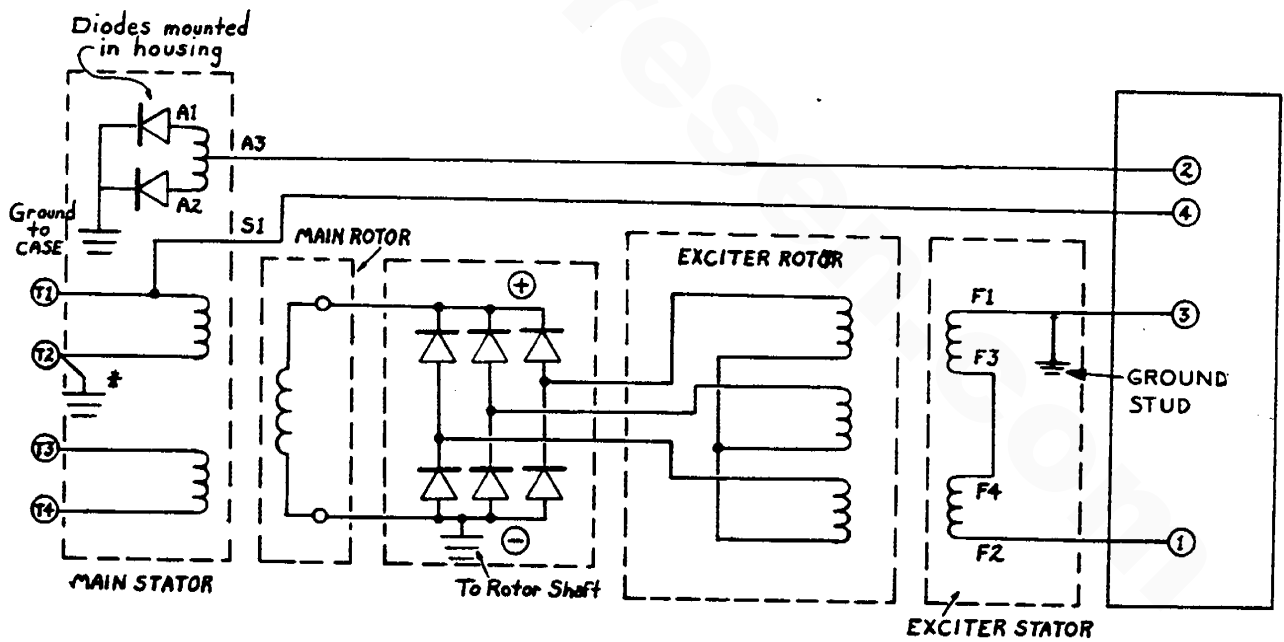
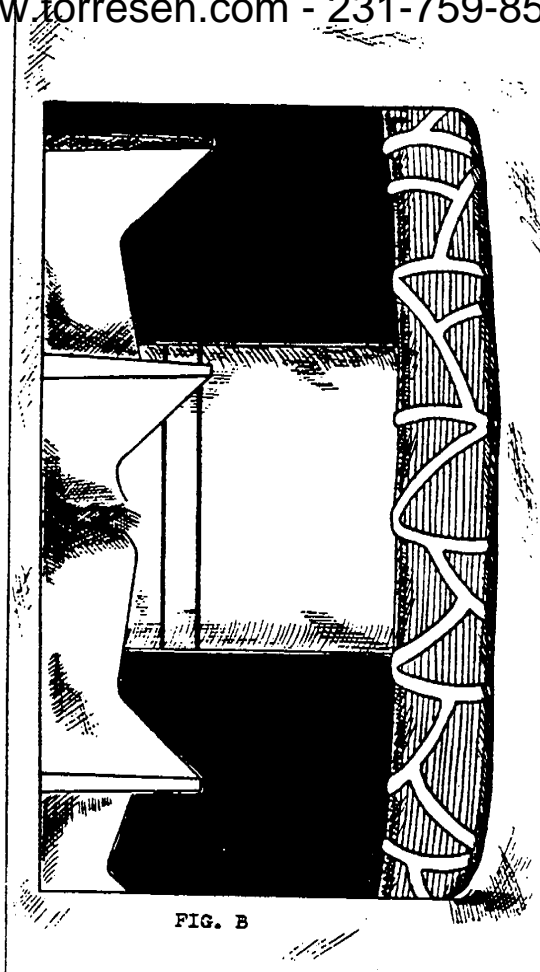
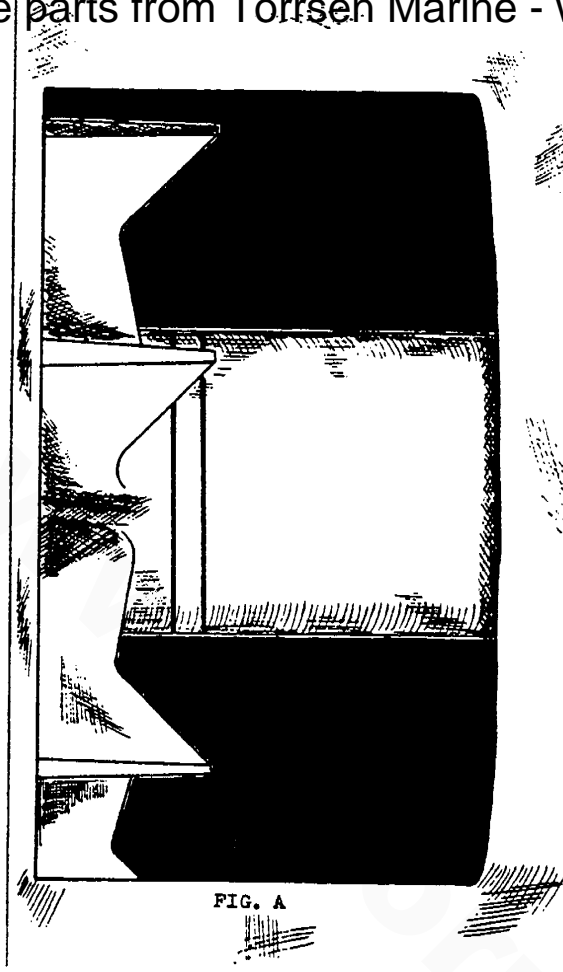

\*User to insure this ground connection is made.

NOTES: F3 & F4 are tied together with butt connector in harness from generator to control panel.

A1 & A2 are accessible only at diodes located in generator housing.

F1 black #16 wire connected to ground stud.

#3 white #16 wire from regulator plug connected to ground stud.



# SERVICE BULLETIN

**DATE:** December 6, 1983

**BULLETIN NUMBER:** 133

**MODEL:** W10-Two, W-13, W-21, W-27, W-30, W-33, W-40, W-50, W-52, W-58  
W-70, W-80, W-100, W-120 (All related Generators)

**SUBJECT:** Zinc Pencil - #11885

A zinc pencil PN #11885 is located in the sea water cooling circuit of all primary heat exchangers on the above models. The purpose of the zinc pencil is to sacrifice itself to electrolysis action taking place in the salt water cooling circuit. This zinc pencil should be periodically checked by unscrewing it from its mounting boss on the exchanger. For the location of the zinc on your model, refer to the cooling system section in your parts manual. Replace the zinc pencil as inspection dictates (refer to Illustration A).

Should material be flaking off the zinc, it should be scraped clean, or be replaced by a good solid zinc pencil.

If it appears that a lot of material has been flaking off the zinc, then it is advised that the end cap of the exchanger be removed, and the flaked material be cleaned from that area of the exchanger. A new end cap gasket should be on hand in case it is needed when replacing the end cap.

Refer to Service Bulletin #84 when removing end caps made of rubber.

ILLUSTRATION A

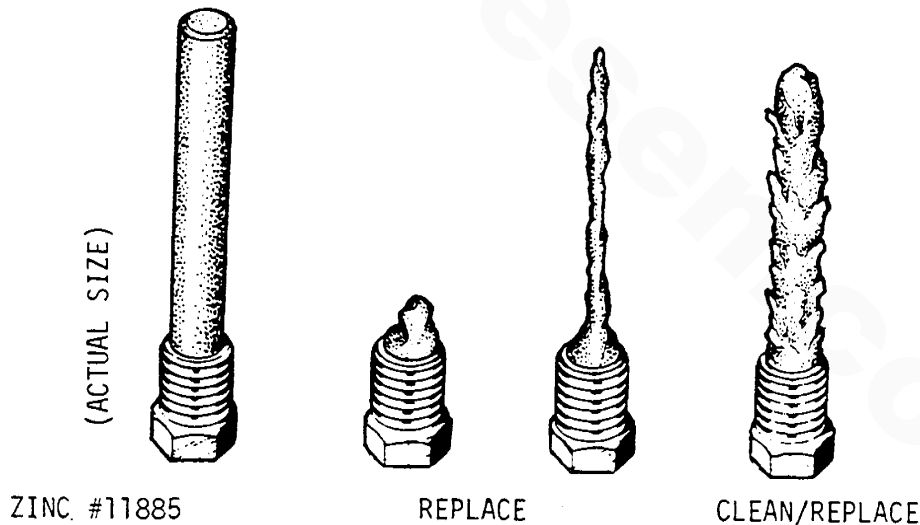

**J. H. WESTERBEKE CORP.**

AVON INDUSTRIAL PARK, AVON, MASS. 02322 · (617) 588-7700  
CABLE: WESTCORP, AVON · TELEX: 92-4444

P/N:

33577

[www.torresen.com](http://www.torresen.com)

[www.torresen.com](http://www.torresen.com)

[www.torresen.com](http://www.torresen.com)