

PARTS LIST

WESTERBEKE 52
Marine Diesel Engine

WESTERBEKE 15 KW
Marine Diesel Generator

Publication # 32416

Edition One

August 1982



PARTS LIST

WESTERBEKE 52
Marine Diesel Engine

WESTERBEKE 15 KW
Marine Diesel Generator

Publication # 32416

Edition One

August 1982



IMPORTANT

PRODUCT SOFTWARE NOTICE

Product software of all kinds, such as brochures, drawings, technical data, operator's and workshop manuals, parts lists and parts price lists, and other information, instructions and specifications provided from sources other than Westerbeke, is not within Westerbeke's control and, accordingly, is provided to Westerbeke customers only as a courtesy and service. WESTERBEKE CANNOT BE RESPONSIBLE FOR THE CONTENT OF SUCH SOFTWARE, MAKES NO WARRANTIES OR REPRESENTATIONS WITH RESPECT THERETO, INCLUDING THE ACCURACY, TIMELINESS OR COMPLETENESS THEREOF, AND WILL IN NO EVENT BE LIABLE FOR ANY TYPE OF DAMAGES OR INJURY INCURRED IN CONNECTION WITH, OR ARISING OUT OF, THE FURNISHING OR USE OF SUCH SOFTWARE.

For example, components and sub-assemblies incorporated in Westerbeke's products and supplied by others (such as engine blocks, fuel systems and components, transmissions, electrical components, pumps and other products) are generally supported by their manufacturers with their own software, and Westerbeke must depend on such software for the design of Westerbeke's own product software. Such software may be outdated and no longer accurate. Routine changes made by Westerbeke's suppliers, of which Westerbeke rarely has notice in advance, are frequently not reflected in the supplier's software until after such changes take place.

Westerbeke customers should also keep in mind the time span between printings of Westerbeke product software, and the unavoidable existence of earlier, non-current Westerbeke software editions in the field. Additionally, most Westerbeke products include customer-requested special features that frequently do not include complete documentation.

In sum, product software provided with Westerbeke products, whether from Westerbeke or other suppliers, must not and cannot be relied upon exclusively as the definitive authority on the respective product. It not only makes good sense, but is imperative that appropriate representatives of Westerbeke or the supplier in question be consulted to determine the accuracy and currency of the product software being consulted by the customer.

TABLE OF CONTENTS

200	Cylinder Block
202	Cylinder Head
204	Crankshaft - Piston
206	Valves - Camshaft - Rocker Shaft
208	Timing Gear Cover
210	Intake Manifold
212	Oil Sump
214	Lube Oil Pump
216	Oil Filter - Solenoid Bracket
218	Exhaust Manifold
222	Flowcontroller
224	Exhaust Connection
226	Cooling System
230	Hydraulic Transmission Oil Cooler
232	Sea Water Pump
234	Fresh Water Pump
236	Fuel System
240	Fuel Injection Pump
242	Primary Fuel Filter
244	Common Back End
248	Alternator Mount
250	Extra 55 Amp Alternator
252	Electrical System - Marine
256	Marine Instrument Panel
258	Electrical System - Generator
260	Generator Control Panel
262	Transmission - Coupling
264	HBW Shift Connection
266	Generator and Back End
270	Miscellaneous

WESTERBEKE 52 - CYLINDER BLOCK

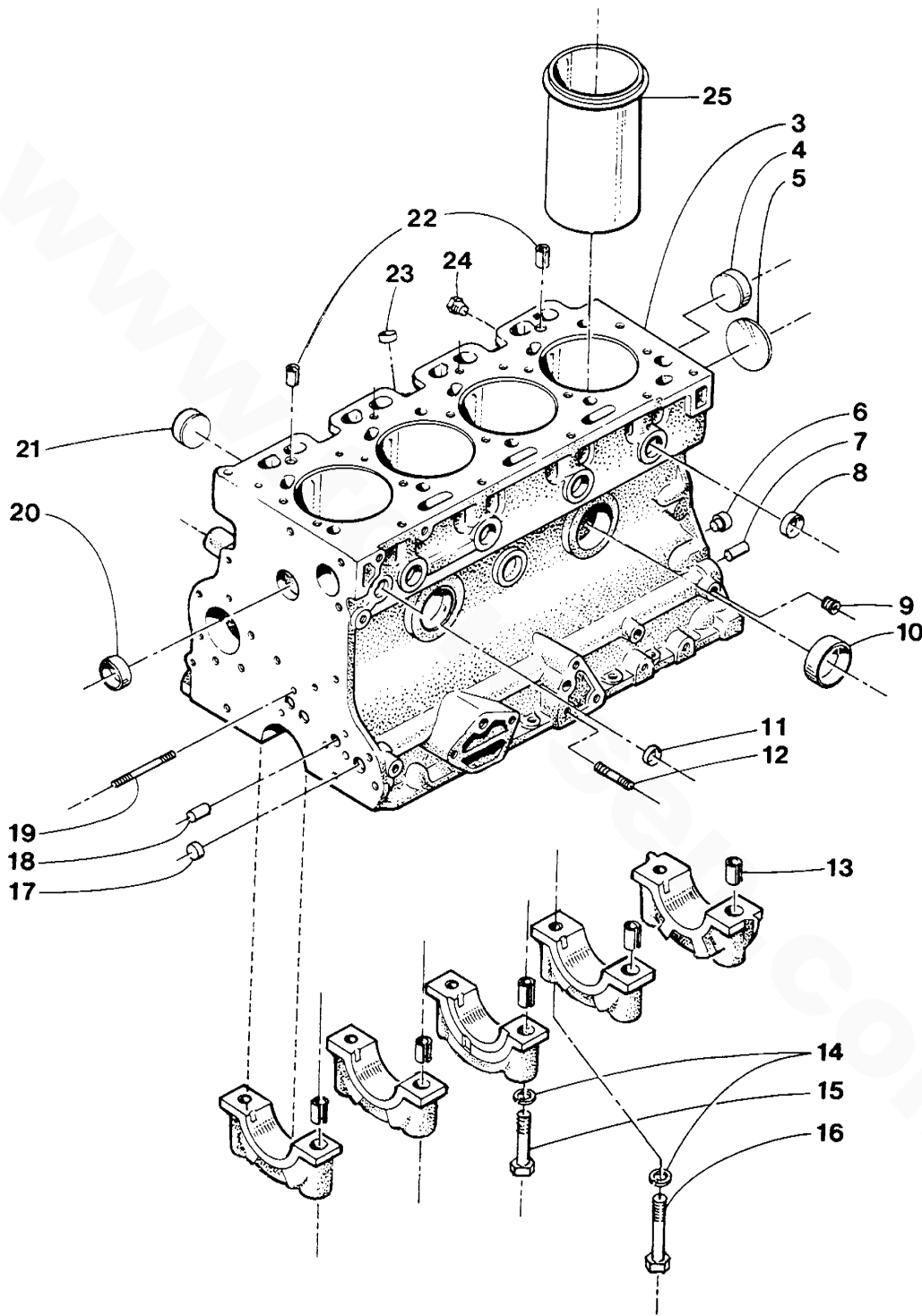

WESTERBEKE 52 - CYLINDER BLOCK

REF	PN	NAME	REMARKS	QUAN
1	24830	BLOCK	ASSEMBLY	1
2	31060	BLOCK	SHORT	1
3	31057	BLOCK	CYLINDER WITH LINERS & PLUGS	1
4	24374	PLUG	EXPANSION	1
5	24379	PLUG	CAMSHAFT	1
6	19039	DOWEL	BLOCK TO BACKPLATE	2
7	24393	PLUG	OIL GALLERY-REAR OF BLOCK	2
8	24373	PLUG	EXPANSION	4
9	24523	PLUG	1/8NPT	4
10	24378	PLUG	EXPANSION	2
11	24369	PLUG	EXPANSION	1
12	32369	STUD	7/16NF X 1-5/16	2
13	24383	DOWEL	TUBULAR	10
14	17849	WASHER	FLAT	10
15	24371	BOLT	MAIN BEARING CAP	2
16	24386	BOLT	MAIN BEARING CAP	8
17	24364	FLUG		2
18	32368	PLUG		2
19	30967	STUD	IDLER GEAR	4
20	24374	PLUG	EXPANSION	1
21	24374	PLUG	EXPANSION	5
22	24383	DOWEL	TUBULAR	2
23	24380	PLUG	OIL PUMP	1
24	24601	PLUG	1/4NPT SOCKET HEAD	1
25	30988	LINER	CYLINDER	4

WESTERBEKE 52 - CYLINDER HEAD

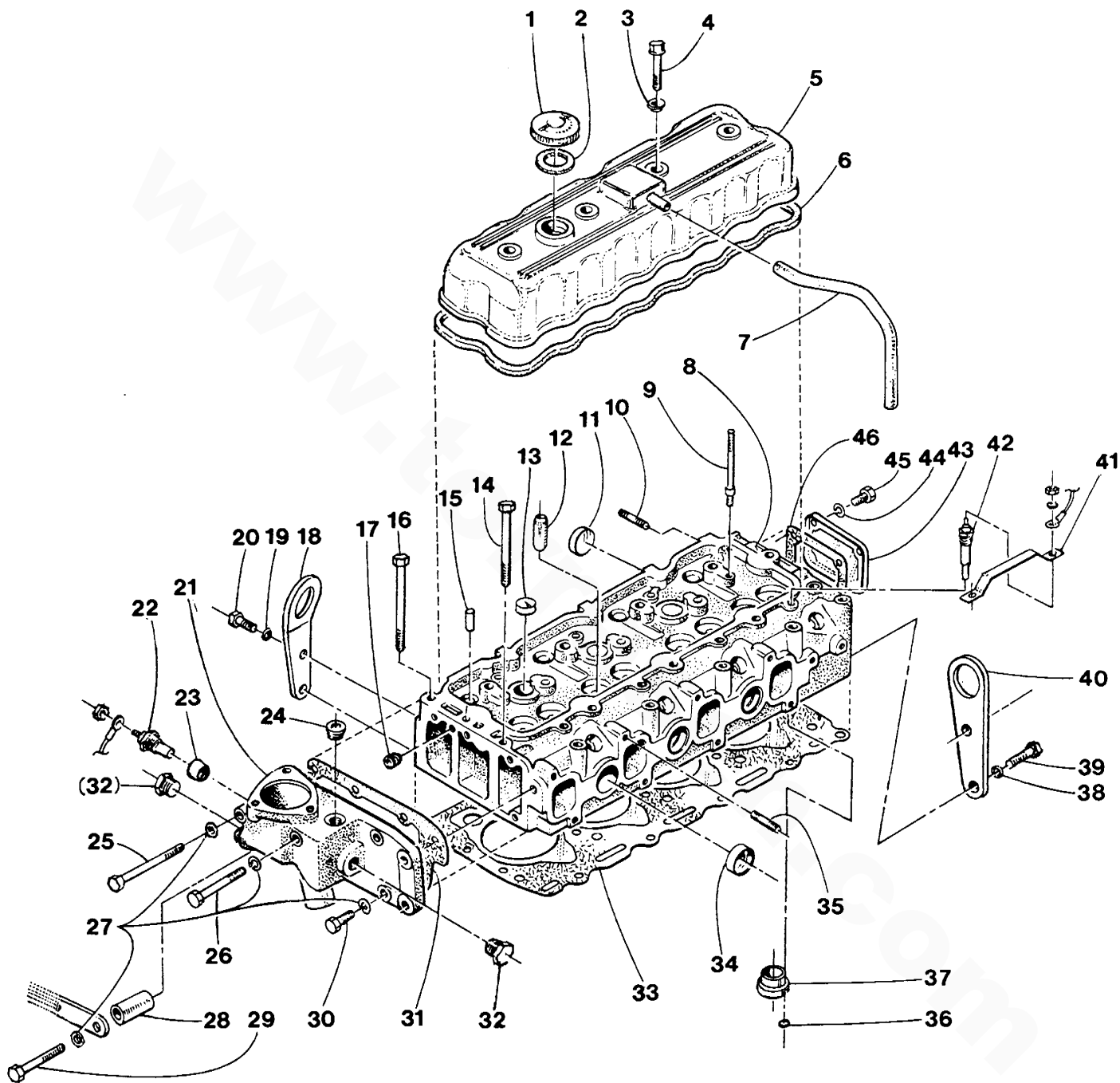

WESTERBEKE 52 - CYLINDER HEAD

REF	PN	NAME	REMARKS	QUAN
1	30986	CAP	OIL FILLER WITH GASKET	1
2		GASKET	OIL FILLER CAP-SEE REF 1	1
3	30985	SEAL		4
4	31577	CAPSCREW	5/16NF X 5/8	4
5	30983	COVER	ROCKER	1
6	30984	GASKET	ROCKER COVER	1
7	32367	HOSE	BREATHER	1
8	30978	HEAD	CYLINDER	1
9	30979	STUD		2
10	12493	STUD	5/16NF X 1 1/4	8
11	24349	PLUG	EXPANSION	4
12	24366	GUIDE	VALVE	8
13	24336	PLUG	BLIND	3
14	24371	BOLT	CYLINDER HEAD 4-1/8LG	13
15	24370	CAP	WATER JET	4
16	24372	BOLT	CYLINDER HEAD 5-7/8LG	7
17	24345	PLUG	OIL GALLERY	1
18	30131	EYE	LIFTING	1
19	31764	LOCKWASHER	3/8	2
20	31628	CAPSCREW	3/8NF X 3/4	2
21	30981	HOUSING	LOWER THERMOSTAT	1
22	23571	SENDER	WATER TEMPERATURE	1
23	24672	BUSHING	HOUSING TO 1/8NPT FOR SENDER	1
24	24903	PLUG	3/8-19 BSPT DIN 916	1
25	31592	CAPSCREW	5/16NF X 3-7/8	1
26	31590	CAPSCREW	5/16NF X 3-3/8	1
27	31758	LOCKWASHER	5/16	6
28	31318	SPACER		1
29	31584	CAPSCREW	5/16NF X 2	1
30	31580	CAPSCREW	5/16NF X 1	3
31	30982	GASKET	THERMOSTAT HOUSING TO HEAD	1
32	22205	PLUG	M16 DIN 910	2
33	30987	GASKET	CYLINDER HEAD	1
34	24349	PLUG	EXPANSION	3
35	12493	STUD	5/16NF X 1-1/4	7
36	24368	WASHER	WELCH	4
37	30980	INSERT	COMBUSTION	4
38	31764	LOCKWASHER	3/8	2
39	31628	CAPSCREW	3/8NF X 3/4	2
40	24521	EYE	LIFTING	1
41	32366	WIRE	GLOWPLUG CONNECTING	1
42	24353	GLOWPLUG		4
43	24376	PLATE	CYLINDER HEAD REAR	1
44	31758	LOCKWASHER	5/16	4
45	31577	CAPSCREW	5/16NF X 5/8	4
46	24377	GASKET	HEAD TO REAR PLATE	1

WESTERBEKE 52 - CRANKSHAFT - PISTON

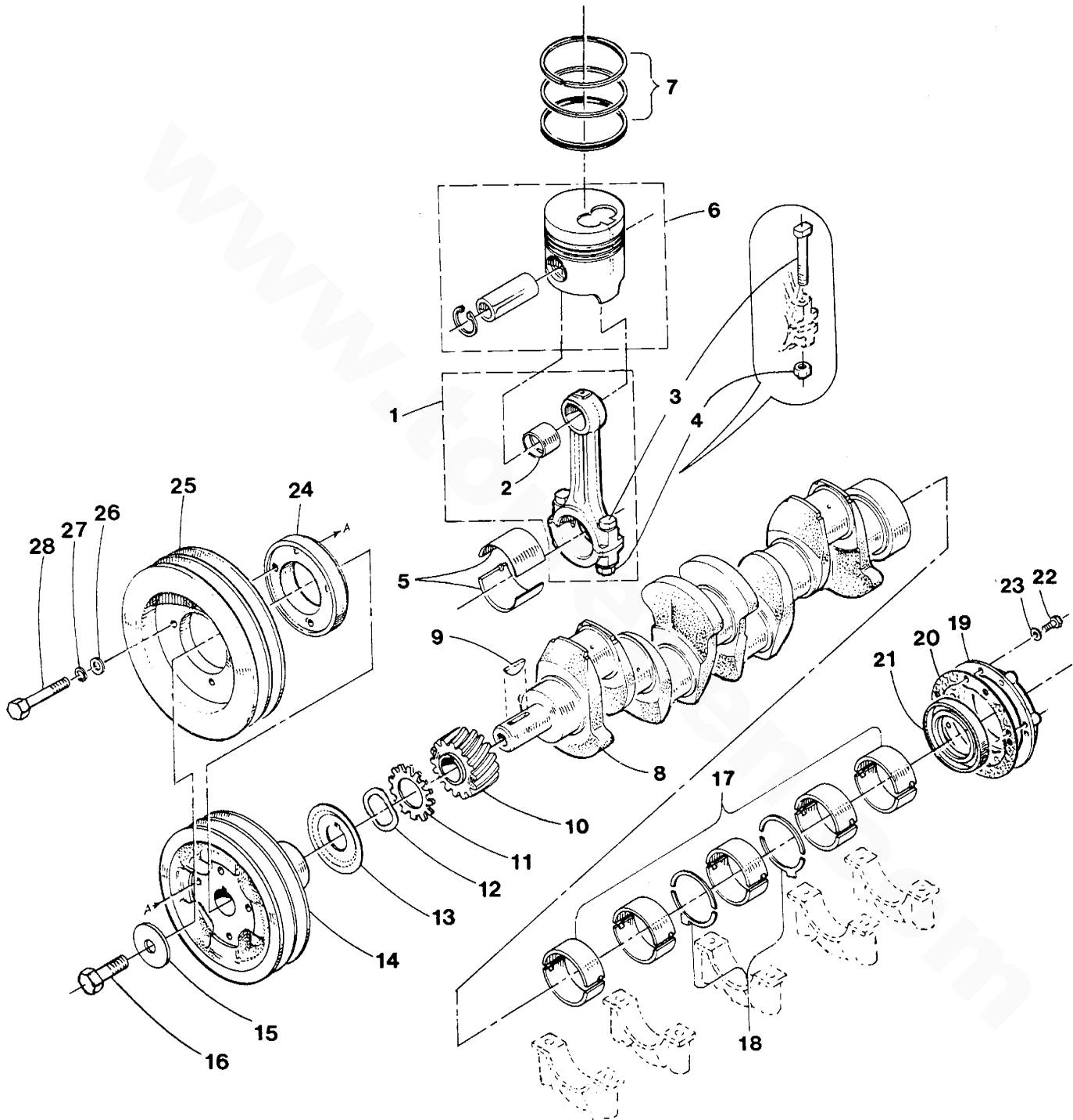

WESTERBEKE 52 - CRANKSHAFT - PISTON

REF	PN	NAME	REMARKS	QUAN
1	30997	ROD	CONNECTING	4
2	32372	BUSHING	CONNECTING ROD	4
3	30998	BOLT	CONNECTING ROD	8
4	30999	NUT	CONNECTING ROD BOLT	8
5- 1	31038	BEARING	SET-CONNECTING ROD-STD	1
5- 2	31039	BEARING	SET-CONNECTING ROD-0.254MM	1
5- 3	31040	BEARING	SET-CONNECTING ROD-0.508MM	1
5- 4	31041	BEARING	SET-CONNECTING ROD-0.762MM	1
6	31059	PISTON	STD	4
7	31048	RING SET	STD	4
8	31000	CRANKSHAFT		1
9	24407	KEY	WOODRUFF	1
10	31001	GEAR	CRANKSHAFT	1
11	31003	GEAR	FRICTION	1
12	31002	SPRING	FRICTION GEAR	1
13	31004	SLINGER	CRANKSHAFT FRONT	1
14	31102	PULLEY	CRANKSHAFT	1
15	24409	WASHER	CRANKSHAFT PULLEY	1
16	12613	BOLT	CRANKSHAFT PULLEY	1
17- 1	31042	BEARING	SET-MAIN-STD	1
17- 2	31043	BEARING	SET-MAIN-0.254MM	1
17- 3	31044	BEARING	SET-MAIN-0.508MM	1
17- 4	31045	BEARING	SET-MAIN-0.762MM	1
18- 1	31046	WASHER	THRUST-SET-STD	1
18- 2	31047	WASHER	THRUST-SET-0.356MM	1
19	30974	FLANGE	OIL SEAL-CRANKSHAFT REAR	1
20	30975	GASKET	CRANKSHAFT OIL SEAL FLANGE	1
21	30976	SEAL	OIL-CRANKSHAFT REAR	1
22		CAPSCREW	5/16NF X 1-3/8	8
23	31758	LOCKWASHER	5/16	8
24	31104	SPACER	ACCESSORY PULLEY TO CRANKSHAFT PULLEY	1
25- 1	23792	PULLEY	ACCESSORY CRANKSHAFT 3 GROOVE 5 INCH	1
25- 2	23790	PULLEY	ACCESSORY CRANKSHAFT 2 GROOVE 6 INCH	1
25- 3	23784	PULLEY	ACCESSORY CRANKSHAFT 2 GROOVE 7 INCH	1
25- 4	23478	PULLEY	ACCESSORY CRANKSHAFT 1 GROOVE 9 INCH	1
26	31759	WASHER	FLAT 5/16	4
27	31758	LOCKWASHER	5/16	4
28- 1	31590	CAPSCREW	5/16NF X 3-1/2 FOR 23792 PULLEY	4
28- 2	31584	CAPSCREW	5/16NF X 2 FOR 23784-23790 PULLEY	4
29	30996	CIRCLIP	PISTON PIN RETAINING	8

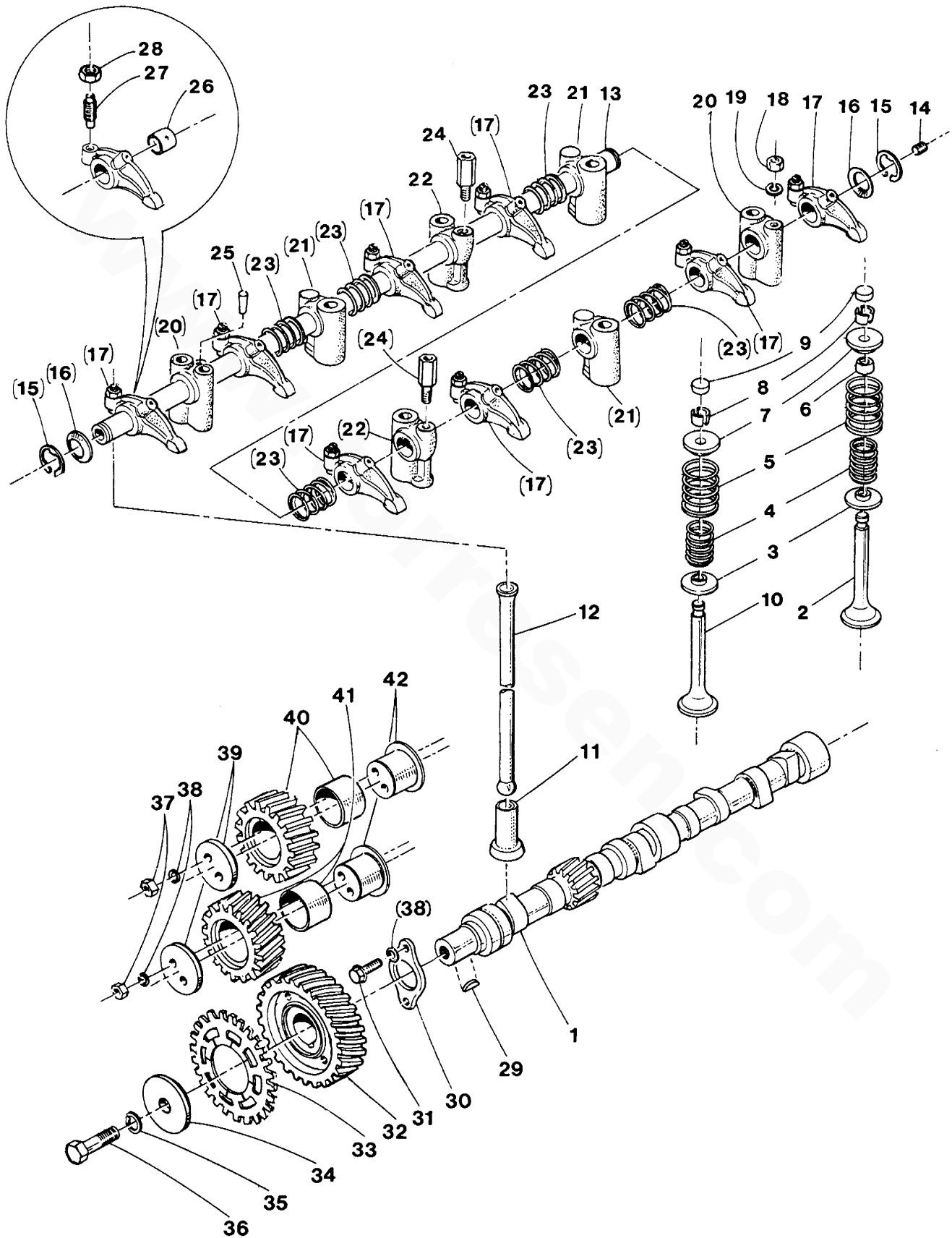

WESTERBEKE 52 - VALVES - CAMSHAFT - ROCKER SHAFT

REF	PN	NAME	REMARKS	QUAN
1	31017	CAMSHAFT		1
2	24423	VALVE	INTAKE	4
3	24427	COLLAR	VALVE SPRING-LOWER	8
4	24426	SPRING	VALVE-INNER	8
5	24425	SPRING	VALVE-OUTER	8
6	24428	SEAL	OIL-VALVE STEM	4
7	24424	COLLAR	VALVE SPRING-UPPER	8
8	24429	COTTER	VALVE	16
9	24351	CAP	VALVE STEM	8
10	24348	VALVE	EXHAUST	4
11	24348	TAPPET		8
12	31010	PUSHROD		8
13	24433	SHAFT	ROCKER INCLUDES 2 PLUGS	1
14	12446	FLUG	ROCKER SHAFT END	2
15		CIRCLIP		2
16	24437	WASHER	ROCKER SHAFT	2
17	24430	ROCKER	ARM-INCLUDES BUSHING,SCREW,LOCKNUT	8
18		NUT	3/8NF SELF-LOCKING	2
19	31764	LOCKWASHER	3/8	2
20	24434	BRACKET	ROCKER SHAFT	2
21	24435	BRACKET	ROCKER SHAFT	3
22	31008	BRACKET	ROCKER SHAFT	2
23	24436	SPRING	ROCKER SHAFT	6
24	31009	ADAPTER	ROCKER COVER	2
25	32384	PIN	TAPER	1
26	24431	BUSHING	ROCKER ARM	8
27	24432	SCREW	TAPPET ADJUSTING	8
28	12433	NUT	5/16NF JAM SELF-LOCKING	8
29	24445	KEY	WOODRUFF	1
30	24446	PLATE	CAMSHAFT RETAINING	1
31	31577	CAPSCREW	5/16NF X 5/8	2
32	31013	GEAR	CAMSHAFT	1
33	31015	GEAR	FRICTION	1
34	31014	PLATE	LOCK CAMSHAFT GEAR	1
35	17849	WASHER		1
36	24384	CAPSCREW	CAMSHAFT GEAR	1
37	31760	NUT	5/16NF	4
38	31758	LOCKWASHER	5/16	6
39	24443	PLATE	IDLER GEAR	2
40	31011	GEAR	IDLER-RIGHT	1
41	31012	GEAR	IDLER-LEFT	1
42	30968	HUB	IDLER GEAR	2

WESTERBEKE 52 - TIMING GEAR COVER

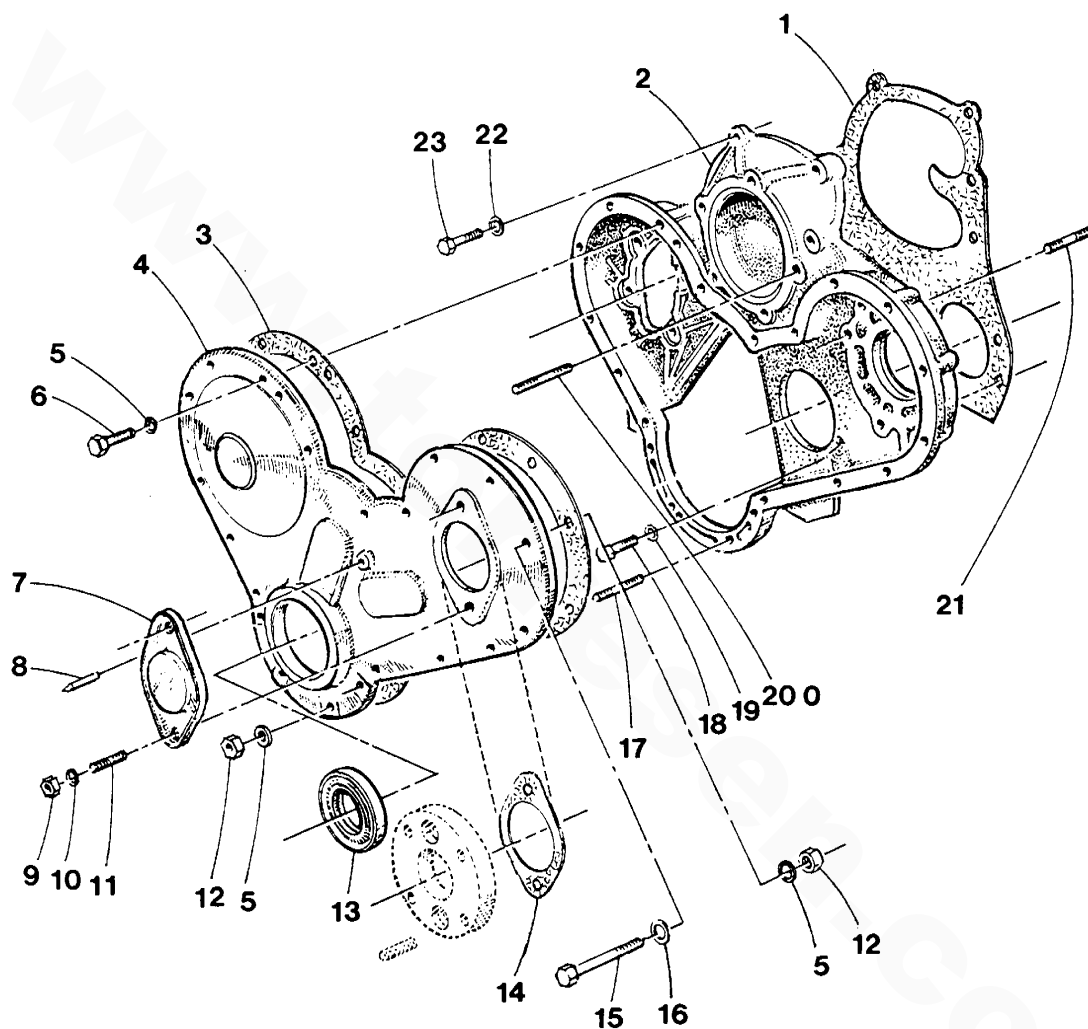

WESTERBEKE 52 - TIMING GEAR COVER

REF	PN	NAME	REMARKS	QUAN
1	30993	GASKET	BLOCK TO TIMING CASE	1
2	30992	CASE	TIMING GEAR	1
3	30995	GASKET	TIMING COVER TO CASE	1
4	30994	COVER	TIMING CASE	1
5	31758	LOCKWASHER	5/16	20
6	31585	CAPSCREW	5/16NF X 2 1/4	9
7	24398	COVER	WHEN NO SEA WATER PUMP IS USED	1
8	30965	POINTER	TIMING	1
9	12433	NUT	5/16NF JAM LOCKING	2
10	31758	LOCKWASHER	5/16	2
11	32381	STUD	5/16NF X 3/4	2
12	31760	NUT	5/16NF	11
13	31056	SEAL	OIL	1
14	24399	GASKET	TIMING COVER TO PUMP ADAPTER	1
15	31587	CAPSCREW	5/16NF X 2-3/4	2
16	31759	WASHER	FLAT 5/16	2
17	32379	STUD	5/16NF X 1-5/8	9
18	31579	CAPSCREW	5/16NF X 7/8	5
19	31758	LOCKWASHER	5/16	5
20	32383	STUD	5/16NF X 2-1/4	5
21	32379	STUD	5/16NF X 1-5/8	2
22	31758	LOCKWASHER	5/16	3
23		CAPSCREW	5/16NF X 1-3/8	3

WESTERBEKE 52 - INTAKE MANIFOLD

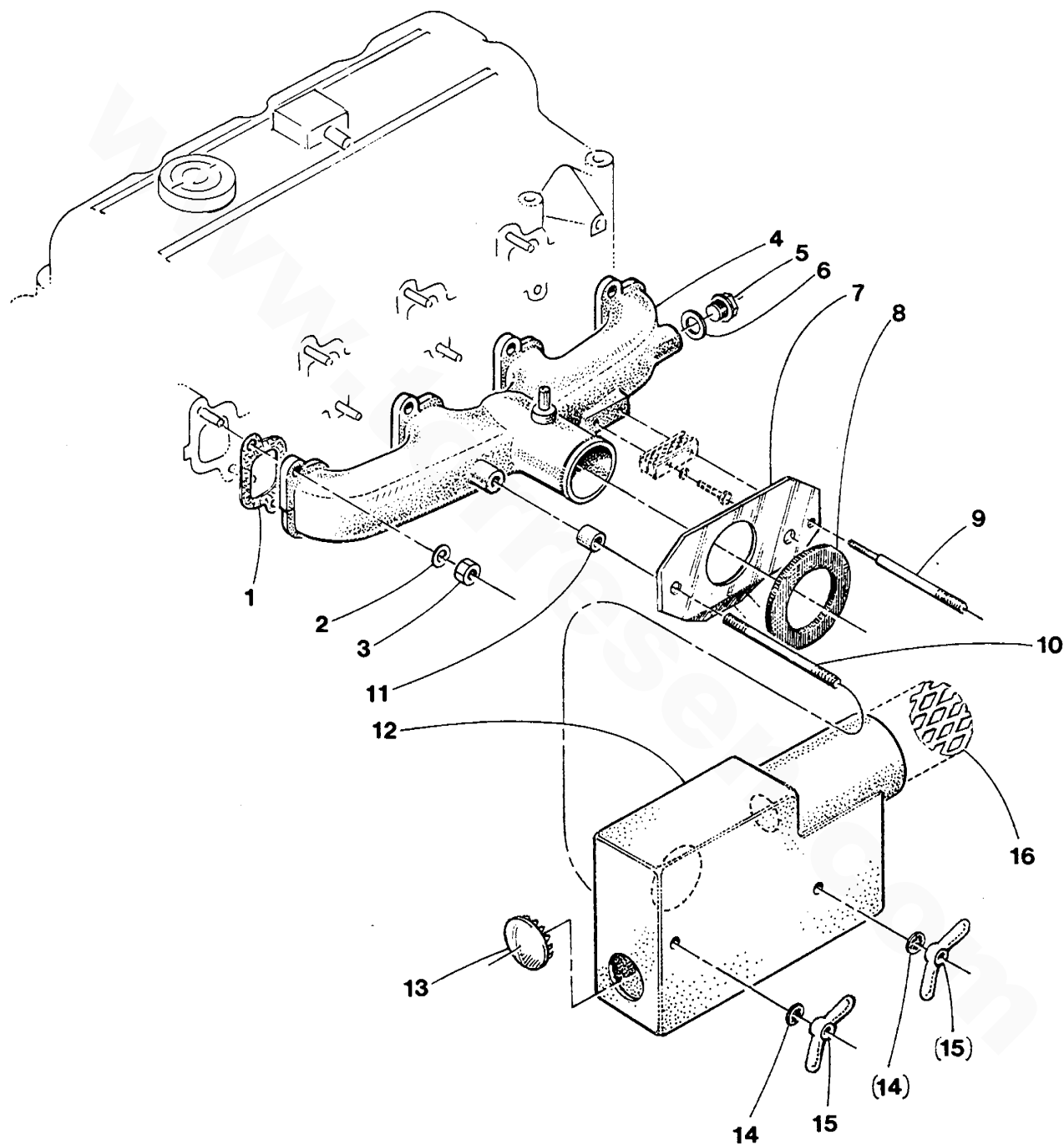

WESTERBEKE 52 - INTAKE MANIFOLD

REF	PN	NAME	REMARKS	QUAN
1	24453	GASKET	INTAKE MANIFOLD TO HEAD	4
2	31758	LOCKWASHER	5/16	7
3	31760	NUT	5/16NF	7
4	31018	MANIFOLD	INTAKE	1
5	32365	PLUG	M18 X 1.5 DIN 910	1
6	24973	WASHER	M18	1
7	30136	PLATE	SILENCER	1
8	30103	GASKET	SILENCER TO PLATE	1
9	30158	STANDOFF	SILENCER	1
10	30114	STUD	SILENCER	1
11	21885	SPACER		1
12- 1	30936	SILENCER	AIR INTAKE-MARINE	1
12- 2	31174	SILENCER	AIR INTAKE-GENSET	1
13	31145	PLUG	INCLUDED IN REF 12	1
14	13567	LOCKWASHER	AIR SILENCER STUD	2
15	16035	WINGNUT	AIR SILENCER STUD	2
16	30167	SCREEN	INCLUDED IN REF 12	1

WESTERBEKE 52 - OIL SUMP

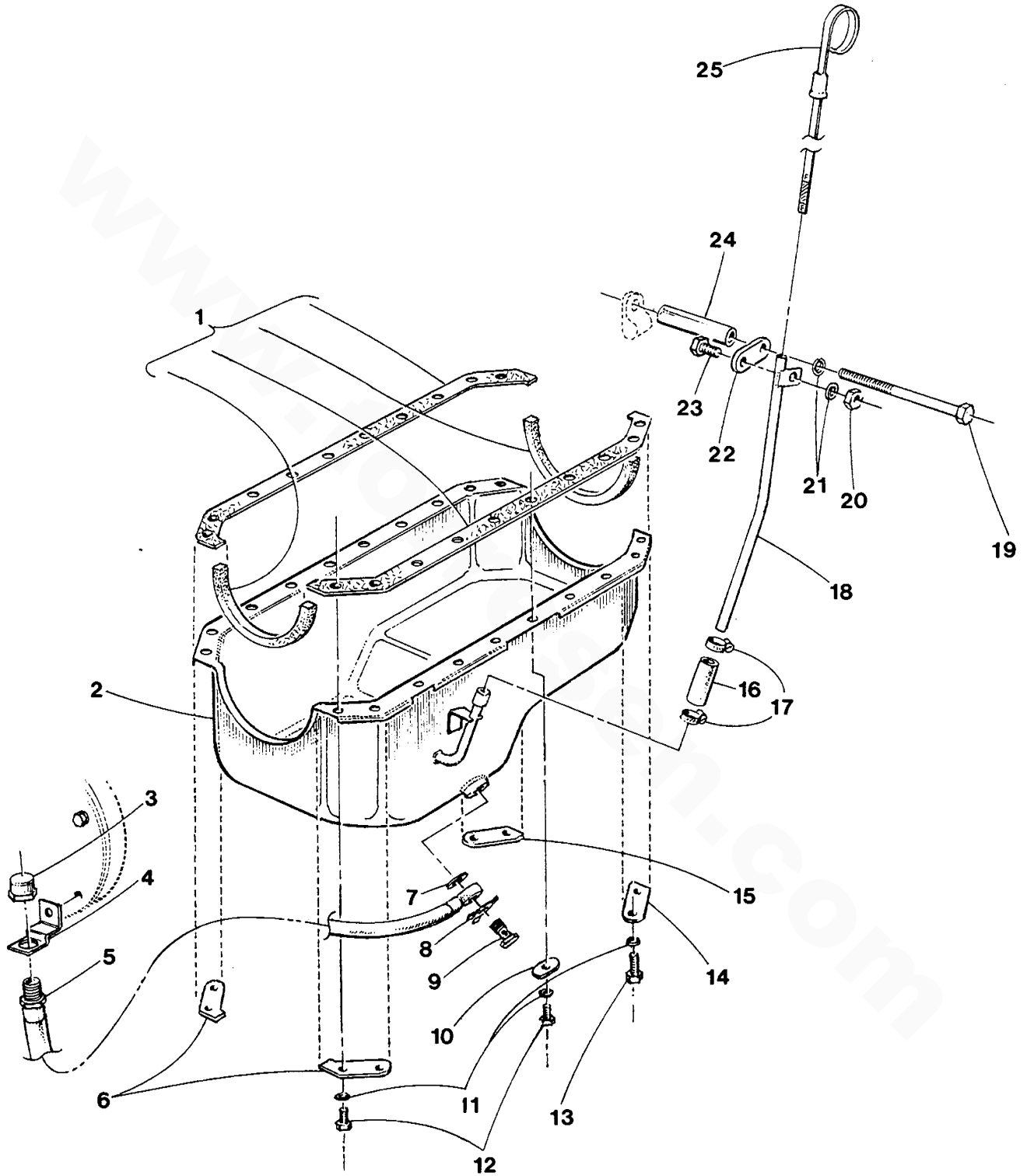

WESTERBEKE 52 - OIL SUMP

REF	PN	NAME	REMARKS	QUAN
1	31051	GASKET SET	SUMP	1
2	31058	SUMP	OIL	1
3	24905	CAP	SUMP DRAIN HOSE	1
4	24922	BRACKET	SUMP DRAIN HOSE	1
5	31173	HOSE	ASSEMBLY-SUMP DRAIN	1
6	30989	STIFFENER	FRONT	2
7	30291	WASHER	BANJO	1
8	24913	TABWASHER		1
9	24901	BOLT	BANJO	1
10	24391	STIFFENER	SIDE	12
11	31758	LOCKWASHER	5/16	20
12	31577	CAPSCREW	5/16NF X 5/8	18
13	31578	CAPSCREW	5/16NF X 3/4	2
14	30973	STIFFENER	REAR	1
15	30972	STIFFENER	REAR	1
16	16694	HOSE	INCHES REQUIRED	2
17	17298	CLAMP	HOSE	2
18	30917	TUBE	DIPSTICK	
19	31592	CAPSCREW	5/16NF X 4	1
20	31756	NUT	5/16NC	1
21	31758	LOCKWASHER	5/16	2
22	11242	STRAP		1
23	31553	CAPSCREW	5/16NC X 3/4	1
24	30956	SPACER		1
25	30991	DIPSTICK		1

WESTERBEKE 52 - LUBE OIL PUMP

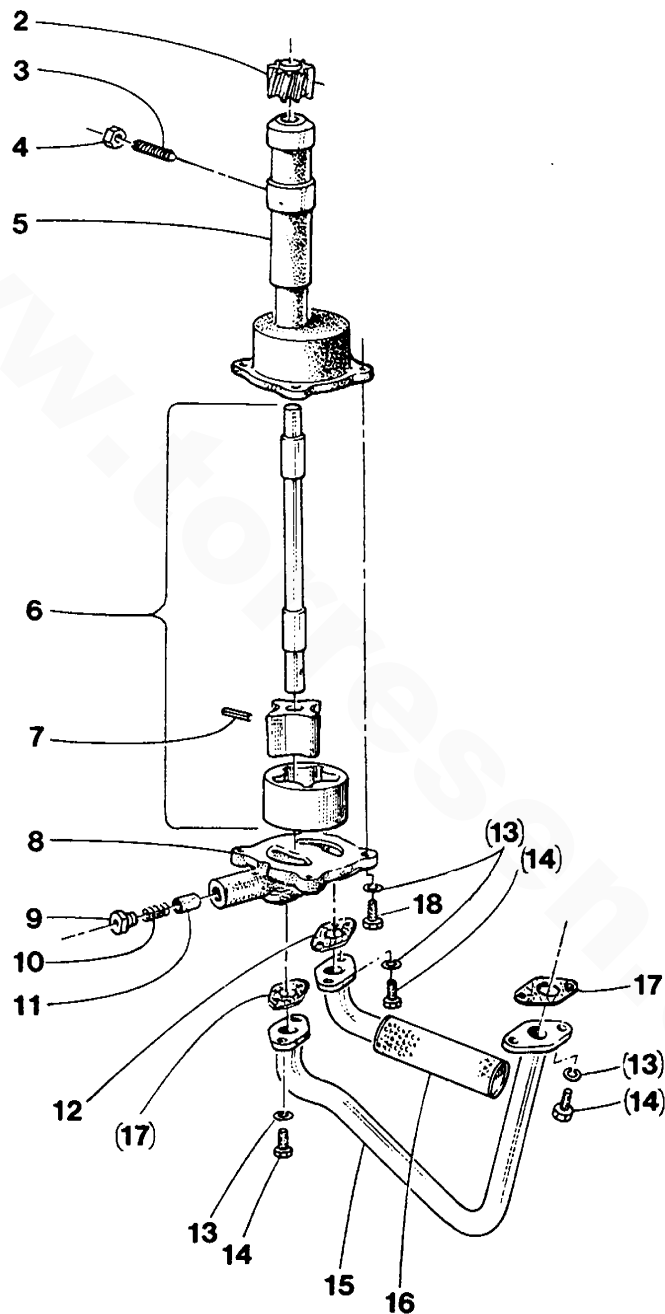

WESTERBEKE 52 - LUBE OIL PUMP

REF	PN	NAME	REMARKS	QUAN
1	31029	PUMP	OIL REF 2 THRU 11	1
2	24469	GEAR	PUMP DRIVE	1
3	24350	SETSCREW	OIL PUMP RETAINING	1
4	31773	NUT	SETSCREW 7/16NF-JAM	1
5		HOUSING	PUMP-SEE REF 1	1
6	31031	SHAFT	DRIVE	1
7	24468	PIN		1
8	31030	COVER	OIL PUMP	1
9	30977	PLUG		1
10	24517	SPRING		1
11	24470	PLUNGER	CONTROL	1
12	30969	GASKET	STRAINER TO PUMP	1
13	31752	LOCKWASHER	1/4	10
14	31527	CAPSCREW	1/4NF X 5/8	6
15	31033	LINE	OIL	1
16	31032	STRAINER	OIL	1
17	24472	GASKET	OIL LINE	2
18	31528	CAPSCREW	1/4NF X 3/4	4

WESTERBEKE 52 - OIL FILTER-SOLENOID BRACKET

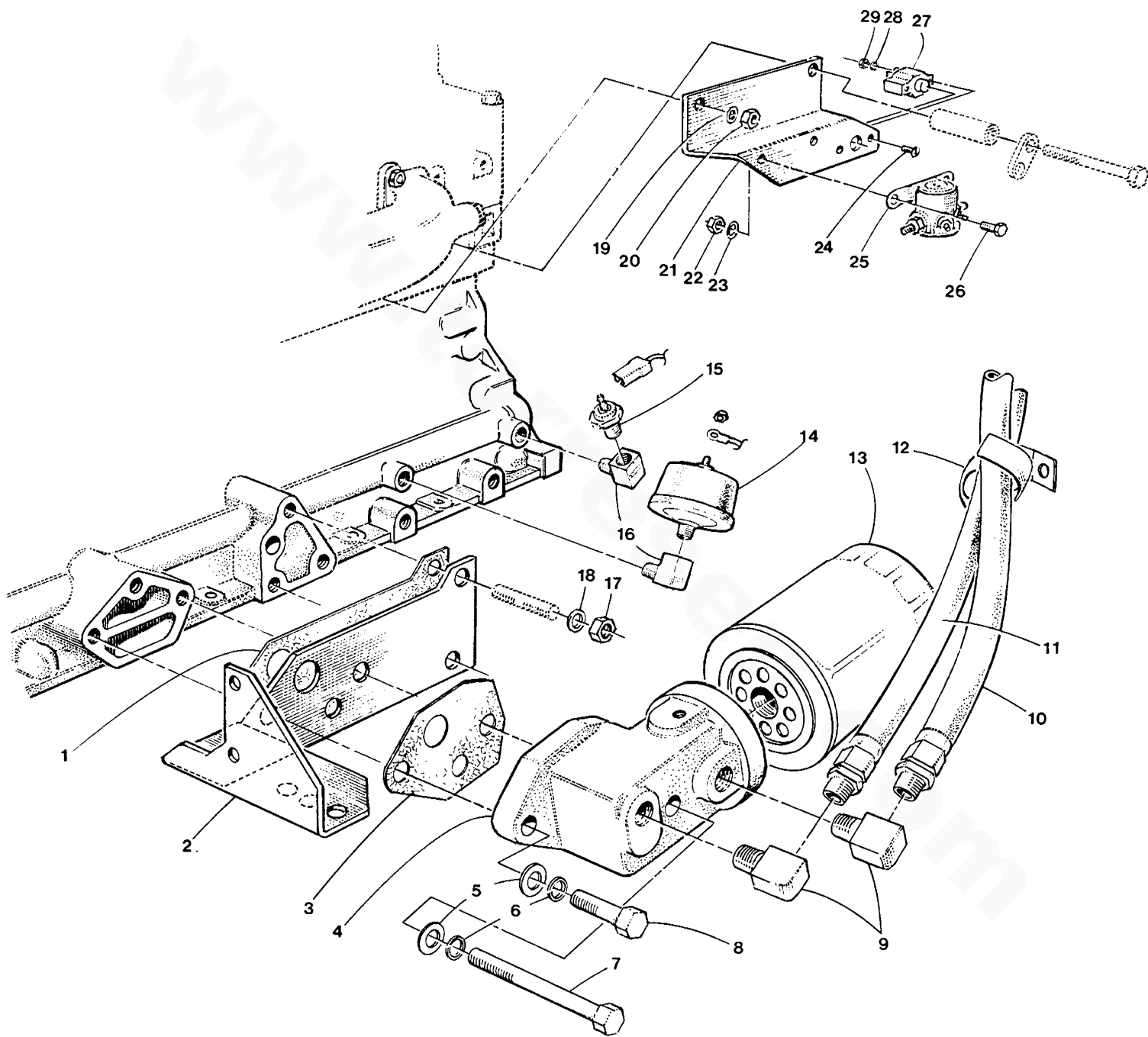

WESTERBEKE 52 - OIL FILTER-SOLENOID BRACKET

REF	PN	NAME	REMARKS	QUAN
1	31496	GASKET	BLOCK TO MOUNT	1
2	30133	MOUNT	FRONT LEFT	1
3	30963	GASKET	MOUNT TO FILTER ADAPTER	1
4	30776	ADAPTER	LUBE OIL FILTER	1
5	31771	WASHER	FLAT 7/16	2
6	31770	LOCKWASHER	7/16	2
7	31692	CAPSCREW	7/16NF X 4	1
8	31683	CAPSCREW	7/16NF X 1-3/4	1
9	13330	ELBOW		2
10	30957	HOSE	OIL 27IN LONG	1
11	30958	HOSE	OIL 31IN LONG	1
12	13741	CLAMP	SUPPORT HOSES	1
13	16655	ELEMENT	LUBE OIL FILTER	1
14	24132	SENDER	OIL PRESSURE	1
15 - 1	30944	SWITCH	OIL PRESSURE-NC-MARINE ALARM	1
15 - 2	32364	SWITCH	OIL PRESSURE-NO-GENSET SAFETY	1
16	11984	ELBOW	STREET 1/8NPT STEEL	2
17	31772	NUT	7/16NF	2
18	31770	LOCKWASHER	7/16	2
19	31758	LOCKWASHER	5/16	1
20	31760	NUT	5/16NF	1
21	30753	BRACKET	GLOWPLUG SOLENOID AND CIRCUIT BREAKER	1
22	31750	NUT	1/4NC	2
23	31752	LOCKWASHER	1/4	2
24		SCREW	8-32 X 1	2
25	24639	SOLENOID	GLOWPLUG	1
26	31501	CAPSCREW	1/4NC X 1/2	2
27	24683	BREAKER	CIRCUIT 20 AMP	1
28		LOCKWASHER	8	2
29		NUT	8-32	2

WESTERBEKE EXTRUDED EXHAUST MANIFOLD

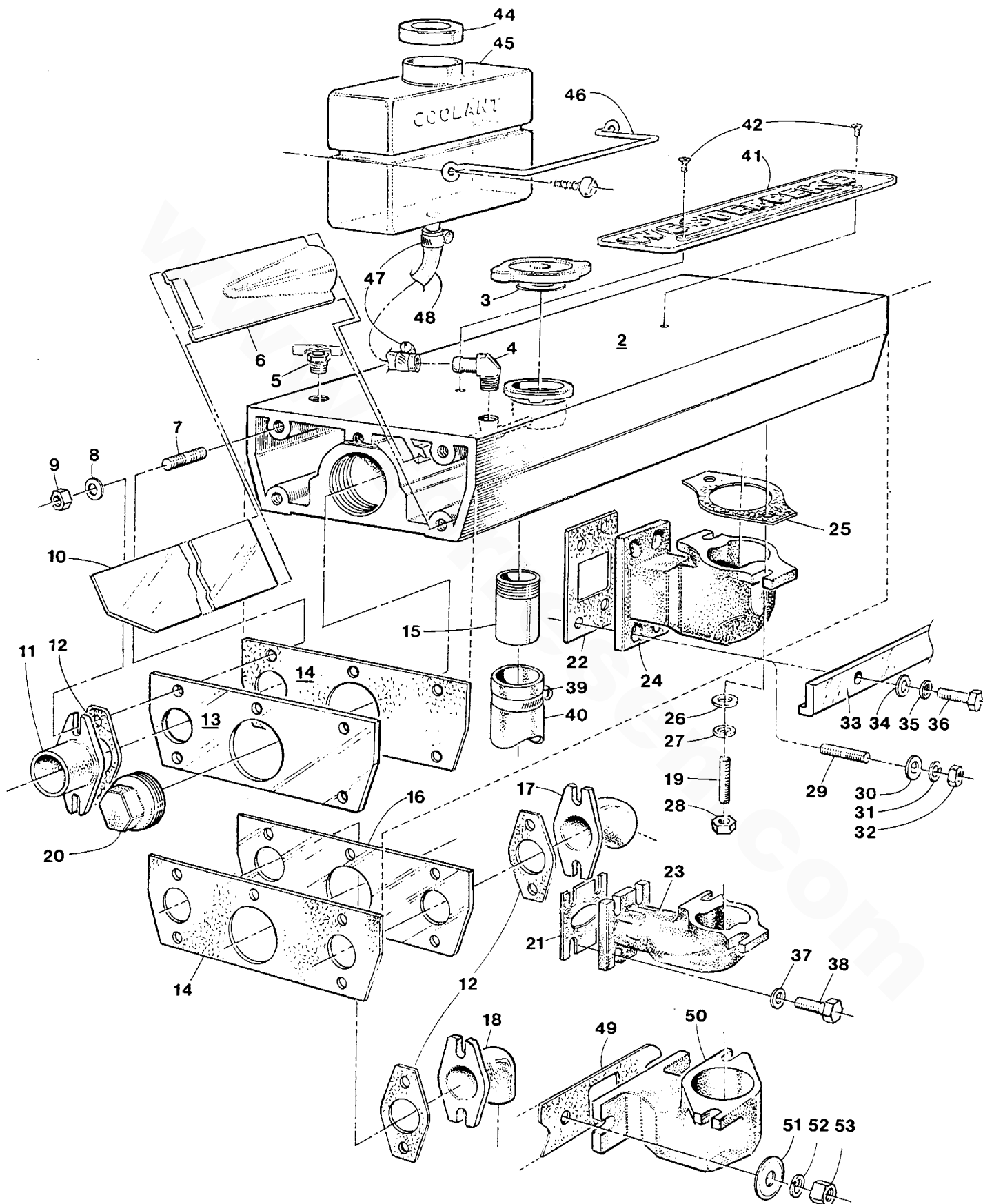

WESTERBEKE EXTRUDED EXHAUST MANIFOLD

REF	PN	NAME	REMARKS	QUAN
2- 1	24298	MANIFOLD	WITH NECK-W13	1
2- 2	24276	MANIFOLD	WITH NECK-W21	1
2- 3	24294	MANIFOLD	WITH NECK-W27	1
2- 4	24300	MANIFOLD	WITH NECK-W33	1
2- 5	30012	MANIFOLD	WITH NECK-W52-58	1
2- 6	30122	MANIFOLD	WITH NECK-W50	1
3	24306	CAP	FILLER	1
4	24907	ELBOW	MANIFOLD TO RECOVERY TANK HOSE	1
5- 1	11471	PETCOCK	MANIFOLD BLEED	1
5- 2	19369	PLUG	BRASS-MANIFOLD BLEED	1
6	24748	DIVERTER		1
7	24838	STUD	MANIFOLD END	10
8	31752	LOCKWASHER	1/4	16
9	31750	NUT	1/4NC	16
10- 1	24843	BAFFLE	W13-21	1
10- 2	30015	BAFFLE	W27	1
10- 3	30016	BAFFLE	W33	1
10- 4	30154	BAFFLE	W52-58	1
10- 5	30153	BAFFLE	W50	1
11	24770	CONNECTOR	FRESH WATER TO MANIFOLD-STRAIGHT	1
12	24763	GASKET	FRESH WATER CONNECTOR	3
13	24779	COVER	MANIFOLD END-FRONT	1
14	24780	GASKET	COVER TO MANIFOLD	2
15	31160	NIPPLE	HOSE	1
16	24775	COVER	MANIFOLD END-REAR	1
17- 1	24772	CONNECTOR	FRESH WATER 45 DEG-W21-27-33-50-52-58	2
17- 2	24772	CONNECTOR	FRESH WATER 45 DEG-W13	1
18	30116	CONNECTOR	FRESH WATER 90 DEG-W13	1
19- 1	11263	STUD	W13	4
19- 2	11263	STUD	W21-50	6
19- 3	11263	STUD	W27-33-52-58	8
20- 1	19324	PLUG	UNUSED EXHAUST OUTLET	1
20- 2		LOC-TITE	ANTI-SEIZE MUST BE USED ON THREADS	
21	30937	GASKET	ELBOW TO HEAD-W13	2
22- 1	24663	GASKET	ELBOW TO HEAD-W21	3
22- 2	24663	GASKET	ELBOW TO HEAD-W27-33-52-58	4
23	24784	ELBOW	MANIFOLD TO HEAD-W13	2
24- 1	24270	ELBOW	MANIFOLD TO HEAD-W21	3
24- 2	24270	ELBOW	MANIFOLD TO HEAD-W27-33-52-58	4
25- 1	24662	GASKET	MANIFOLD TO ELBOW-W13	2
25- 2	24662	GASKET	MANIFOLD TO ELBOW-W21-50	3
25- 3	24662	GASKET	MANIFOLD TO ELBOW-W27-33-52-58	4
26- 1	31759	WASHER	FLAT 5/16-W13	4
26- 2	31759	WASHER	FLAT 5/16-W21-50	6
26- 3	31759	WASHER	FLAT 5/16-W27-33-52-58	8
27- 1	31758	LOCKWASHER	5/16-W13	4
27- 2	31758	LOCKWASHER	5/16-W21-50	6
27- 3	31758	LOCKWASHER	5/16-W27-33-52-58	8
28- 1	31760	NUT	5/16NF-W13	4
28- 2	31760	NUT	5/16NF-W21-50	6
28- 3	31760	NUT	5/16NF-W27-33-52-58	8

WESTERBEKE EXTRUDED EXHAUST MANIFOLD

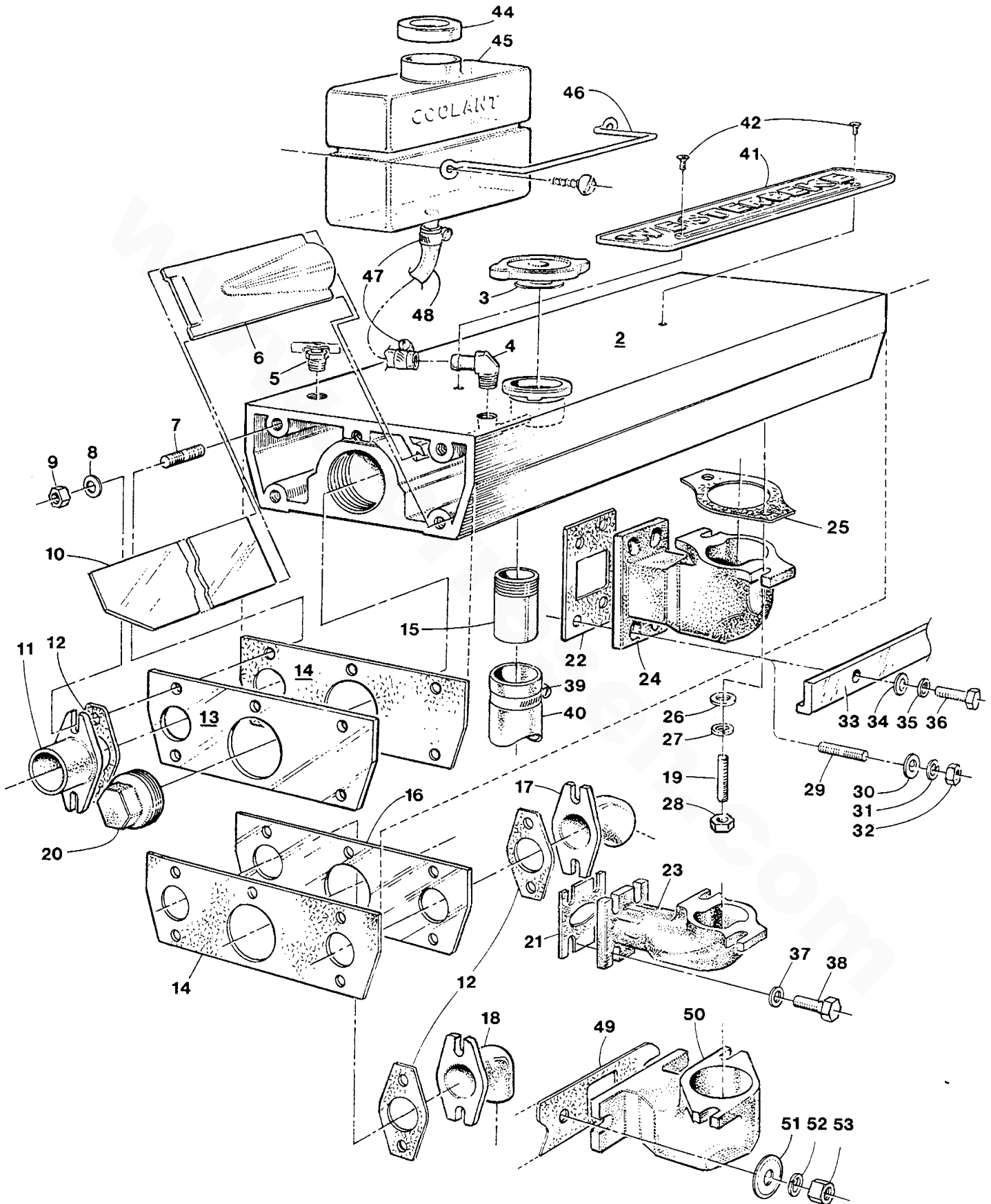

WESTERBEKE EXTRUDED EXHAUST MANIFOLD

REF	PN	NAME	REMARKS	QUAN
29- 1	15830	STUD	ELBOW TO HEAD-W21	6
29- 2	15830	STUD	ELBOW TO HEAD-W27	8
29- 3	12493	STUD	5/16NF X 1-1/4-W52-58	8
30- 1	32273	WASHER	EXHAUST ELBOW-D SHAPE-W21	6
30- 2	32273	WASHER	EXHAUST ELBOW-D SHAPE-W27	8
30- 3	31759	WASHER	FLAT 5/16-W52-58	8
31- 1	31786	LOCKWASHER	M8 DIN 127-W21	6
31- 2	31786	LOCKWASHER	M8 DIN 127-W27	8
31- 3	31758	LOCKWASHER	5/16-W52-58	8
32- 1	18242	NUT	M8 DIN 934-W21	6
32- 2	18242	NUT	M8 DIN 934-W27	8
32- 3	31760	NUT	5/16NF-W52-58	8
33	30027	BRACE	ELBOW CLAMPING-W33	1
34	31789	WASHER	M10 DIN 125-W33	4
35	19262	LOCKWASHER	M10 DIN 127-W33	6
36	31083	CAPSCREW	M10X1.25X30 JIS-W33	6
37- 1	31789	WASHER	M10 DIN 125-W13	4
37- 2	19262	LOCKWASHER	M10 DIN 127-W13	4
38	31083	CAPSCREW	M10X1.25X30 JIS-W13	4
39	21878	CLAMP	HOSE	1
40		HOSE	MANIFOLD TO TUBE-REFER TO COOLING SYSTEM	
41	24986	NAMEPLATE		1
42		SCREW	8-32X1/4 OVAL HEAD SS	2
43	24977	KIT	COOLANT RECOVERY REF 44-48	1
44	24858	CAP	COOLANT RECOVERY TANK	1
45	24704	TANK	COOLANT RECOVERY	1
46	24786	STRAP	TANK MOUNTING	1
47	24906	CLAMP	HOSE	2
48	24637	TUBING	INCHES REQUIRED	30
49	11859	GASKET	HEAD TO MANIFOLD ELBOWS AND SILENCER-W50	1
50- 1	24744	ELBOW	MANIFOLD TO HEAD-ENDS-W50	2
50- 2	24226	ELBOW	MANIFOLD TO HEAD-CENTER-W50	1
51- 1	15441	WASHER	ELBOW AND SILENCER RETAINING	4
51- 2	31759	WASHER	5/16 FLAT-W50	2
52	31758	LOCKWASHER	5/16-W50	6
53	31760	NUT	5/16NF-W50	6

WESTERBEKE 52 - FLOWCONTROLLER

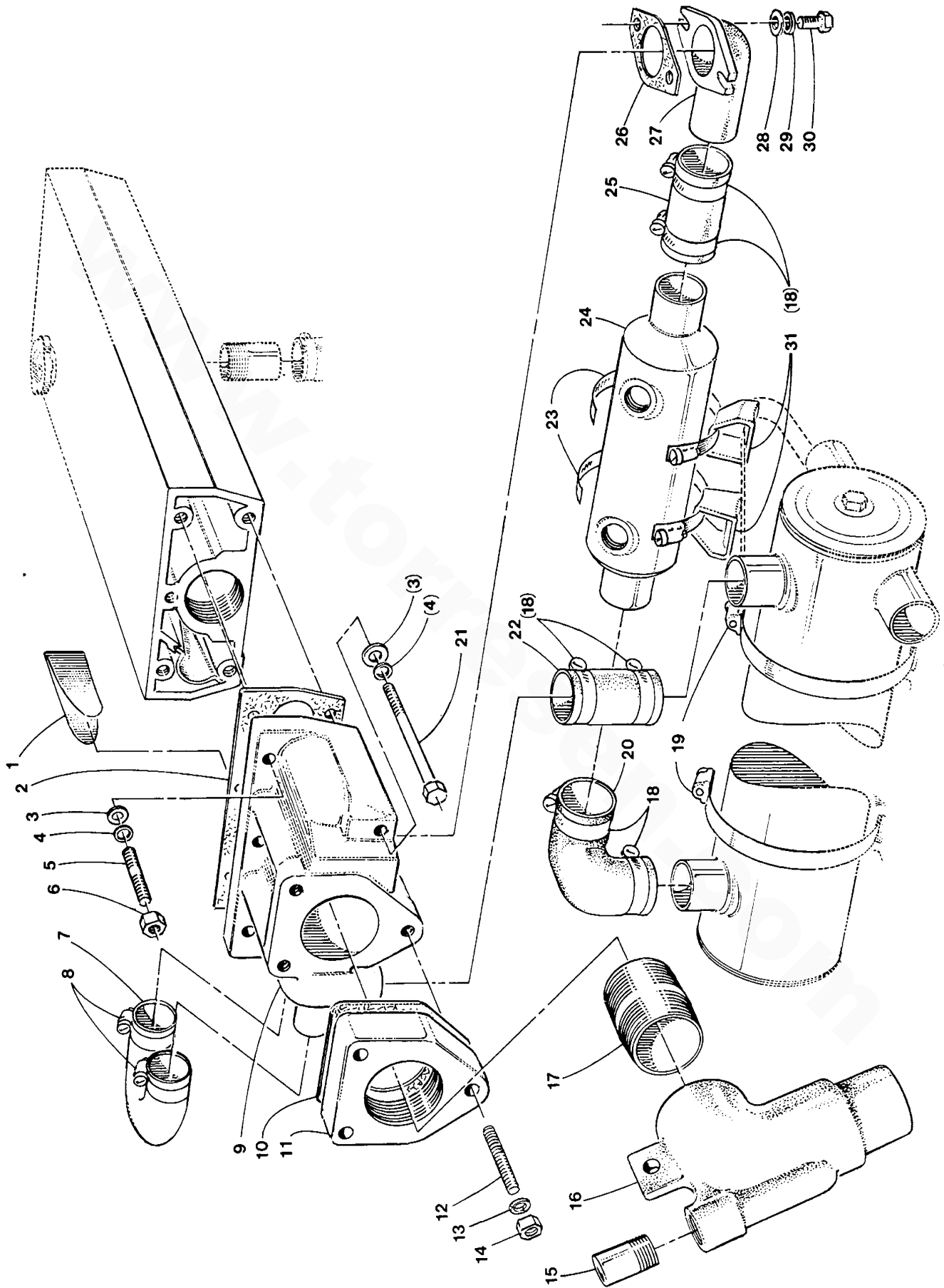

WESTERBEKE 52 - FLOWCONTROLLER

REF	PN	NAME	REMARKS	QUAN
1	30165	SPRING	FLOWCONTROLLER	1
2	24780	GASKET	MANIFOLD TO FLOWCONTROLLER	1
3	31753	WASHER	FLAT 1/4	5
4	31750	LOCKWASHER	1/4	5
5	24832	STUD	MANIFOLD END	4
6	31750	NUT	1/4NC	4
7	30962	RETURNBEND	HOSE-WHEN WATER HEATER NOT INSTALLED	1
8	11386	CLAMP	HOSE 12	2
9	31202	HOUSING	FLOWCONTROLLER	1
10	31206	GASKET	ADAPTER TO FLOWCONTROLLER	1
11	31204	ADAPTER	EXHAUST NIPPLE TO FLOWCONTROLLER	1
12	31492	STUD	5/16NC X 1-7/8	3
13	31758	LOCKWASHER	5/16	3
14	31756	NUT	5/16NC	3
15	32230	NIPPLE	1/2NPT TO 7/8ID HOSE	1
16	15985	ELBOW	WATER INJECTED EXHAUST	1
17	20439	NIPPLE	1.5NPT CLOSE	1
18	21878	CLAMP	HOSE 20	6
19	30047	CLAMP	MOUNT EXCHANGER TO HOUSING	2
20	24305	HOSE	ELBOW	1
21	31514	CAPSCREW	1/4NC X 3-1/4	1
22	24974	HOSE	WIRE INSERTED 1-3/8ID INCHES REQD	6
23	11411	CLAMP	HOSE 32	2
24	24309	COOLER	OIL	1
25	24974	HOSE	WIRE INSERTED 1-3/8ID INCHES REQD	3
26	24763	GASKET	ELBOW TO FLOWCONTROLLER	1
27	31491	ELBOW		1
28	31753	WASHER	FLAT 1/4	2
29	31752	LOCKWASHER	1/4	2
30	31505	CAPSCREW	1/4NC X 1	2
31	24295	ADAPTER	COOLER TO EXCHANGER	2
50- 1		LOC-TITE	ANTI-SEIZE MUST BE USED ON THREADS FOR	
50- 2			EXHAUST CONNECTIONS	

WESTERBEKE 52 - EXHAUST CONNECTION

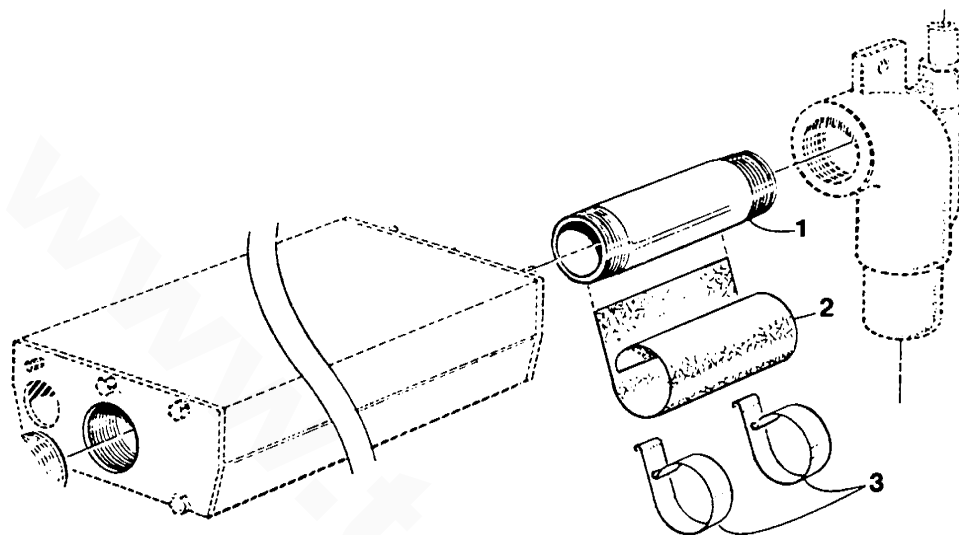

WESTERBEKE 52 - EXHAUST CONNECTION

REF	PN	NAME	REMARKS	QUAN
1- 1	22923	NIPPLE	1.5NPT X 6-REAR EXHAUST-NO FLOWCONTROLLE	1
1- 2	24207	NIPPLE	1.5NPT X 8-FRONT EXHAUST	1
2	30060	INSULATOR	PROTECTS HOSE FROM HEAT	1
3	30058	SPRING	INSULATOR RETAINER	2

www.torresen.com

WESTERBEKE 52 - COOLING SYSTEM

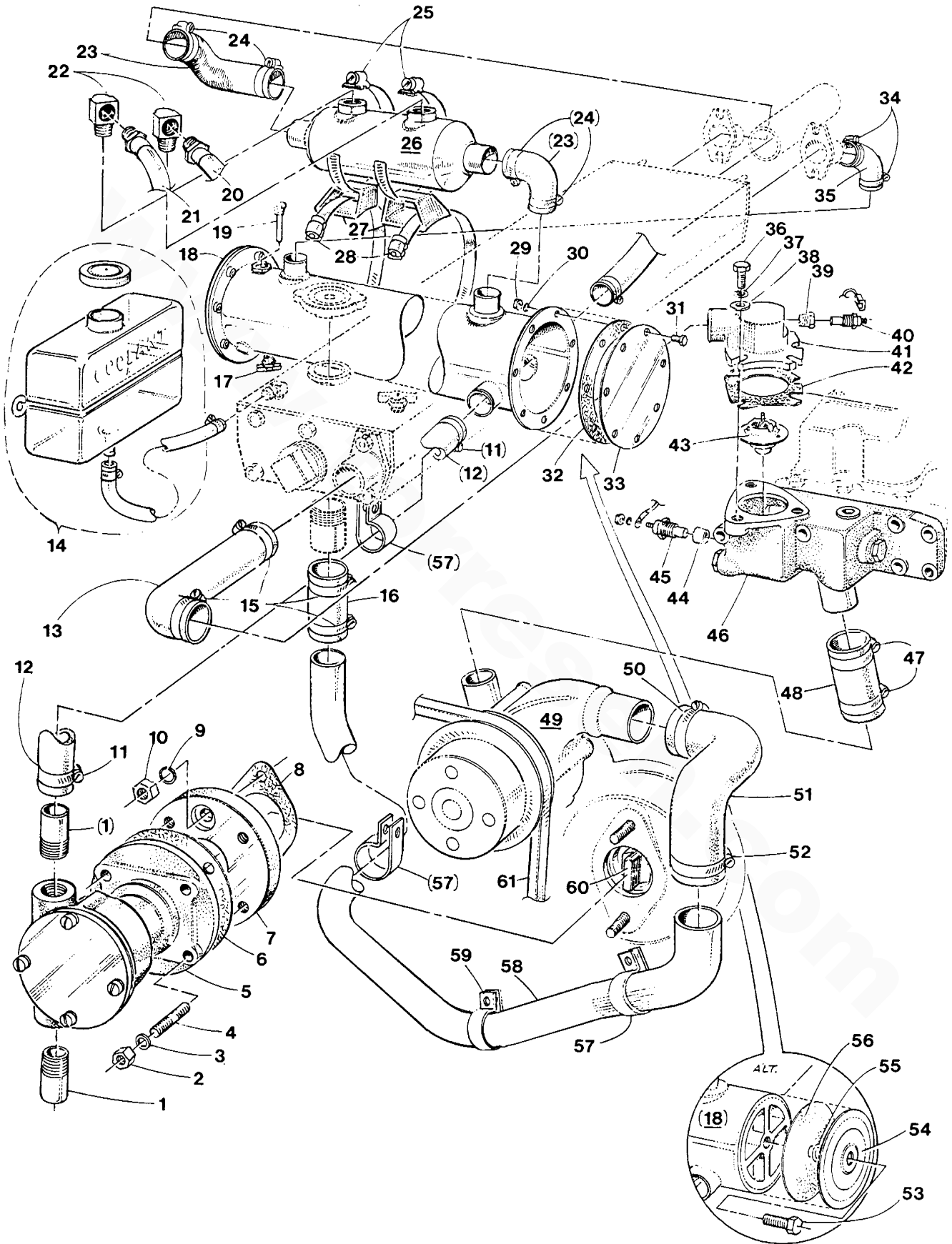

WESTERBEKE 52 - COOLING SYSTEM

REF	PN	NAME	REMARKS	QUAN
1	32230	NIPPLE	1/2NPT TO 7/8ID HOSE	2
2	31760	NUT	5/16NF	4
3	31758	LOCKWASHER	5/16	4
4	11263	STUD		4
5	16423	PUMP	SEA WATER	1
6	11143	GASKET	SEA WATER PUMP TO ADAPTER	1
7	30104	ADAPTER	SEA WATER PUMP TO TIMING COVER	1
8	24399	GASKET	ADAPTER TO TIMING COVER	1
9	31758	LOCKWASHER	5/16	2
10	31761	NUT	5/16NF JAM	2
11	11384	CLAMP	HOSE 12	2
12	19059	HOSE	WIRE INSERTED 7/8ID INCHES REQD	32
13	24334	HOSE	ELBOW	1
14	24977	KIT	COOLANT RECOVERY TANK	1
15	21878	CLAMP	HOSE 20	4
16	24974	HOSE	WIRE INSERTED 1-3/8ID INCHES REQD	4
17	11471	PETCOCK		1
18	24308	EXCHANGER	HEAT	1
19	11885	ZINC		1
20	30957	HOSE	OIL 27IN LONG	1
21	30958	HOSE	OIL 31IN LONG	1
22	13330	ELBOW		2
23	24305	HOSE	ELBOW	2
24	21878	CLAMP	HOSE 20	4
25	11411	CLAMP	HOSE 32	2
26	24309	COOLER	OIL	1
27	24295	ADAPTER	COOLER TO EXCHANGER	2
28	30047	CLAMP	MOUNT EXCHANGER TO HOUSING	2
29	31750	NUT	1/4NC	14
30	31752	LOCKWASHER	1/4	14
31	31500	CAPSCREW	1/4NC X 5/8	14
32	31291	GASKET	EXCHANGER END COVER	2
33	31290	COVER	EXCHANGER END	2
34	21878	CLAMP	HOSE 20	2
35	24974	HOSE	WIRE INSERTED 1-3/8ID INCHES REQD	7
36	31580	CAPSCREW	5/16NF X 1	3
37	31758	LOCKWASHER	5/16	3
38	31759	WASHER	FLAT 5/16	3
39	22131	BUSHING	1/4NPT TO 1/8NPT	1
40- 1	30125	SWITCH	WATER TEMPERATURE FOR ALARM	1
40- 2	30096	SWITCH	WATER TEMPERATURE FOR SAFETY-GENSET	1
41	24258	HOUSING	UPPER THERMOSTAT	1
42	24323	GASKET	THERMOSTAT	1
43	24690	THERMOSTAT	WITH BOTTOM BYPASS AND BLEED HOLE	1
44	24672	BUSHING	HOUSING TO 1/8NPT FOR SENDER	1
45	23571	SENDER	WATER TEMPERATURE	1
46	30981	HOUSING	LOWER THERMOSTAT	1
47	11405	CLAMP	HOSE 16	2
48	24415	HOSE	THERMOSTAT HOUSING TO FRESH WATER PUMP	1
49	32213	PUMP	FRESH WATER	1

WESTERBEKE 52 - COOLING SYSTEM

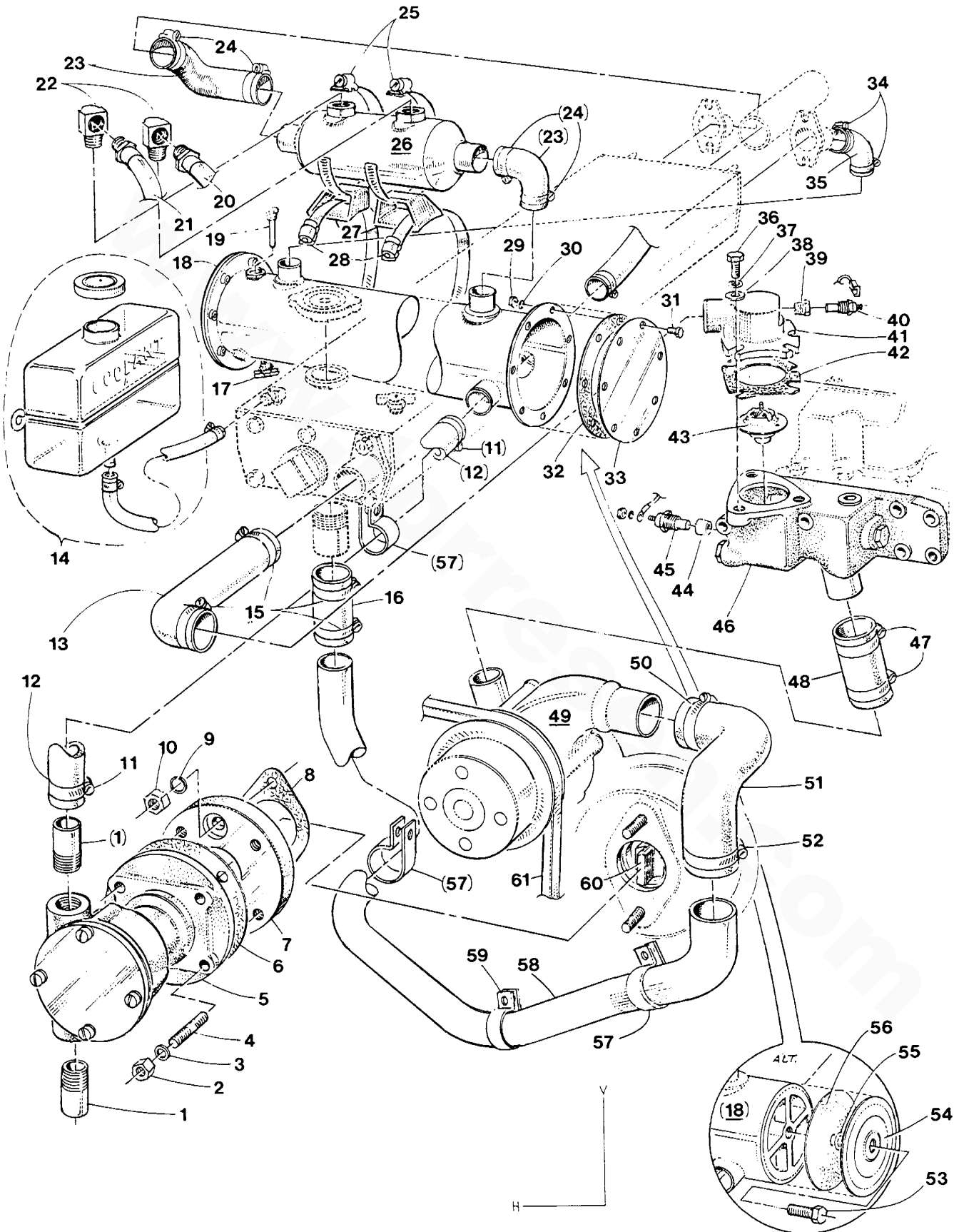

WESTERBEKE 52 - COOLING SYSTEM

REF	PN	NAME	REMARKS	QJAN
50	21122	CLAMP	HOSE 24	1
51	24304	HOSE	ELBOW	1
52	21878	CLAMP	HOSE 20	1
53	22852	CAPSCREW	3/8NC X 1/2 BRASS	2
54	22850	COVER	EXCHANGER END	2
55	19321	O-RING		2
56	22851	GASKET	EXCHANGER END COVER	2
57	13741	CLAMP	SUPPORT TUBE AND HOSE	3
58	30149	TUBE	MANIFOLD TO FRESH WATER PUMP	1
59	12292	CLAMP	SUPPORT TUBE	1
60	30062	TANG	SEA WATER PUMP DRIVE	1
61	19001	BELT	ALTERNATOR AND FRESH WATER PUMP DRIVE	1

HYDRAULIC TRANSMISSION OIL COOLER SYSTEM

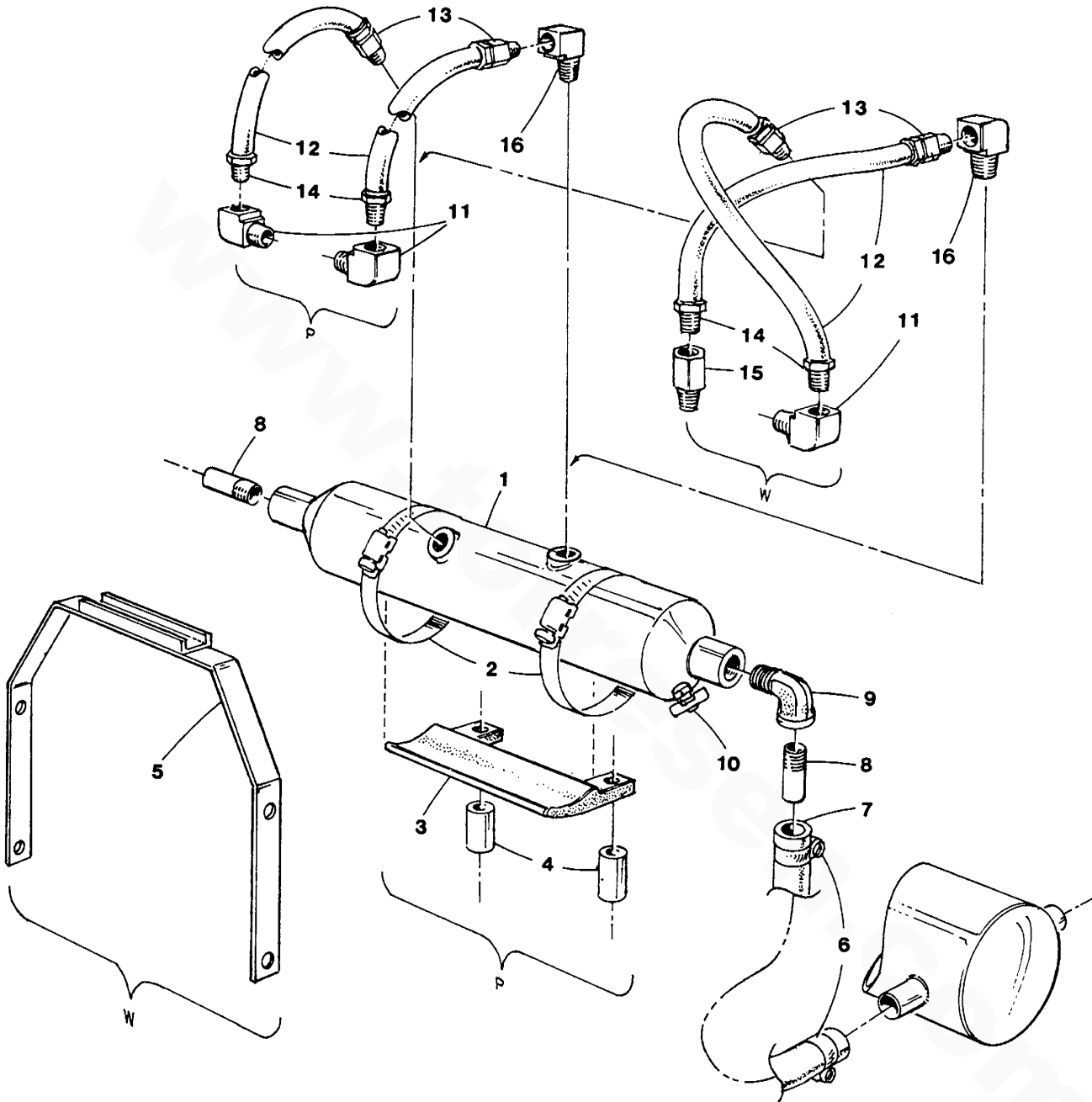

HYDRAULIC TRANSMISSION OIL COOLER SYSTEM

REF	PN	NAME	REMARKS	QUAN
1	11657	COOLER	OIL	1
2	11411	CLAMP	HOSE-MOUNT COOLER TO BRACKET	2
3	11917	BRACKET	OIL COOLER MOUNT ON PARAGON HYDRAULIC	1
4	13621	SPACER	OIL COOLER MOUNT ON PARAGON HYDRAULIC	2
5	13057	BRACKET	OIL COOLER MOUNT ON WARNER HYDRAULIC	1
6	11341	CLAMP	HOSE	2
7	19059	HOSE	INCHES REQUIRED	16
8	32230	NIPPLE	HOSE	2
9	24693	ELBOW		2
10	11471	PETCOCK		1
11- 1	13330	ADAPTER	ELBOW-WARNER HYDRAULIC	1
11- 2	13330	ADAPTER	ELBOW-PARAGON HYDRAULIC	3
12	11775	HOSE	INCHES REQUIRED	AR
13	11777	CONNECTOR	HOSE	2
14	11776	CONNECTOR	HOSE-SWIVEL	2
15	13348	ADAPTER	WARNER HYDRAULIC	1
16	13338	ELBOW	3/4INPT BRASS-STREET	2

WESTERBEKE 52 - SEA WATER PUMP

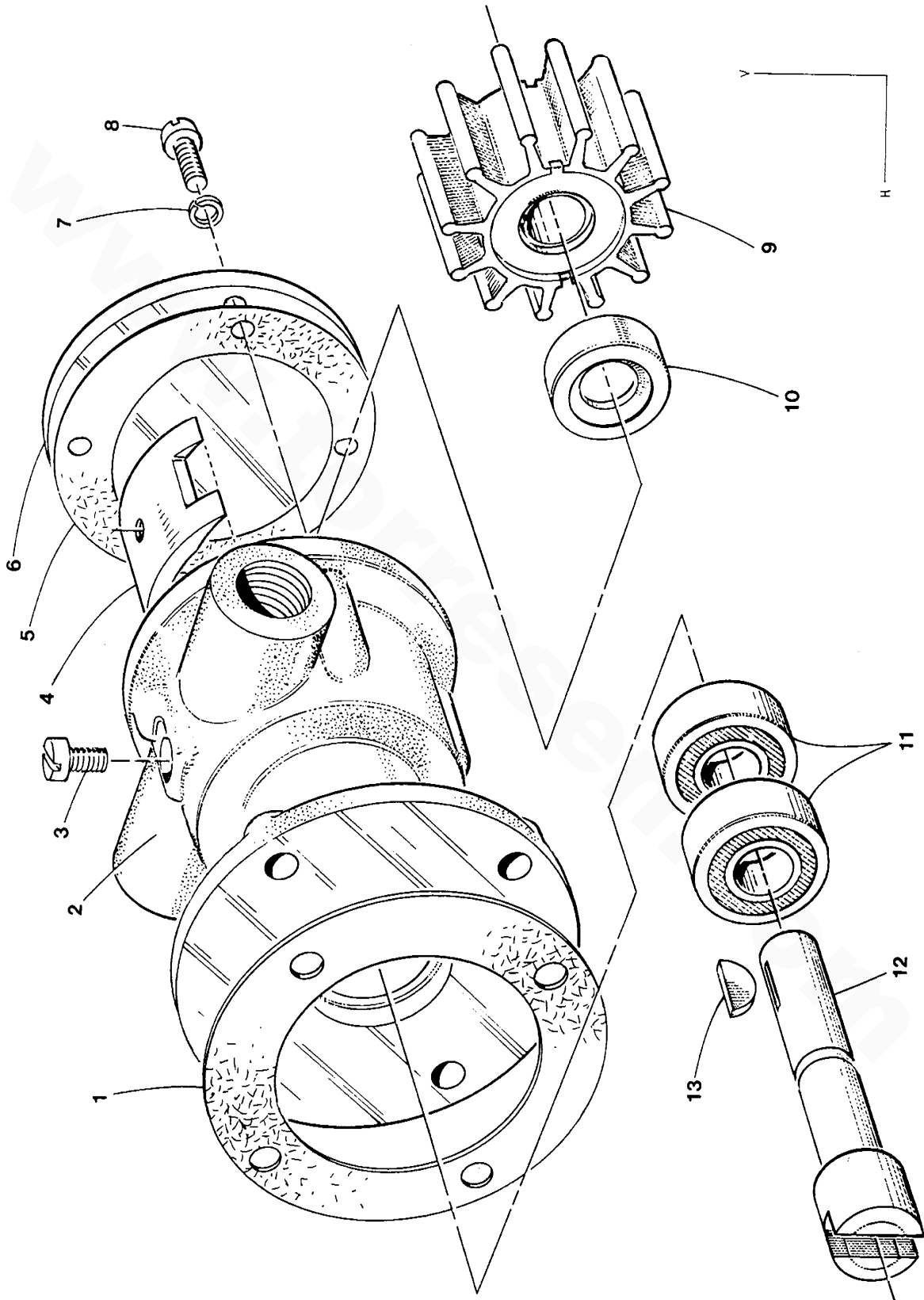

WESTERBEKE 52 - SEA WATER PUMP

REF	PN	NAME	REMARKS	QUAN
1	11143	GASKET	PUMP TO TIMING CASE	1
2- 1	16423	PUMP	COMPLETE	1
2- 2	18169	HOUSING	PUMP BODY	1
2- 3	18172	KIT	MAJOR REPAIR	1
3	18167	SCREW	BRASS-PUMP HOUSING TO CAM	1
4	18152	CAM		1
5	18153	GASKET	IMPELLER COVER	1
6	18171	COVER	IMPELLER	1
7	32183	LOCK WASHER	IMPELLER	4
8	18151	SCREW	BRASS-IMPELLER COVER	4
9	11418	IMPELLER		1
10	18159	SEAL		1
11	1817	BEARING		2
12	18176	SHAFT		1
13	18148	KEY	IMPELLER TO SHAFT	1

WESTERBEKE 52 - FRESH WATER PUMP

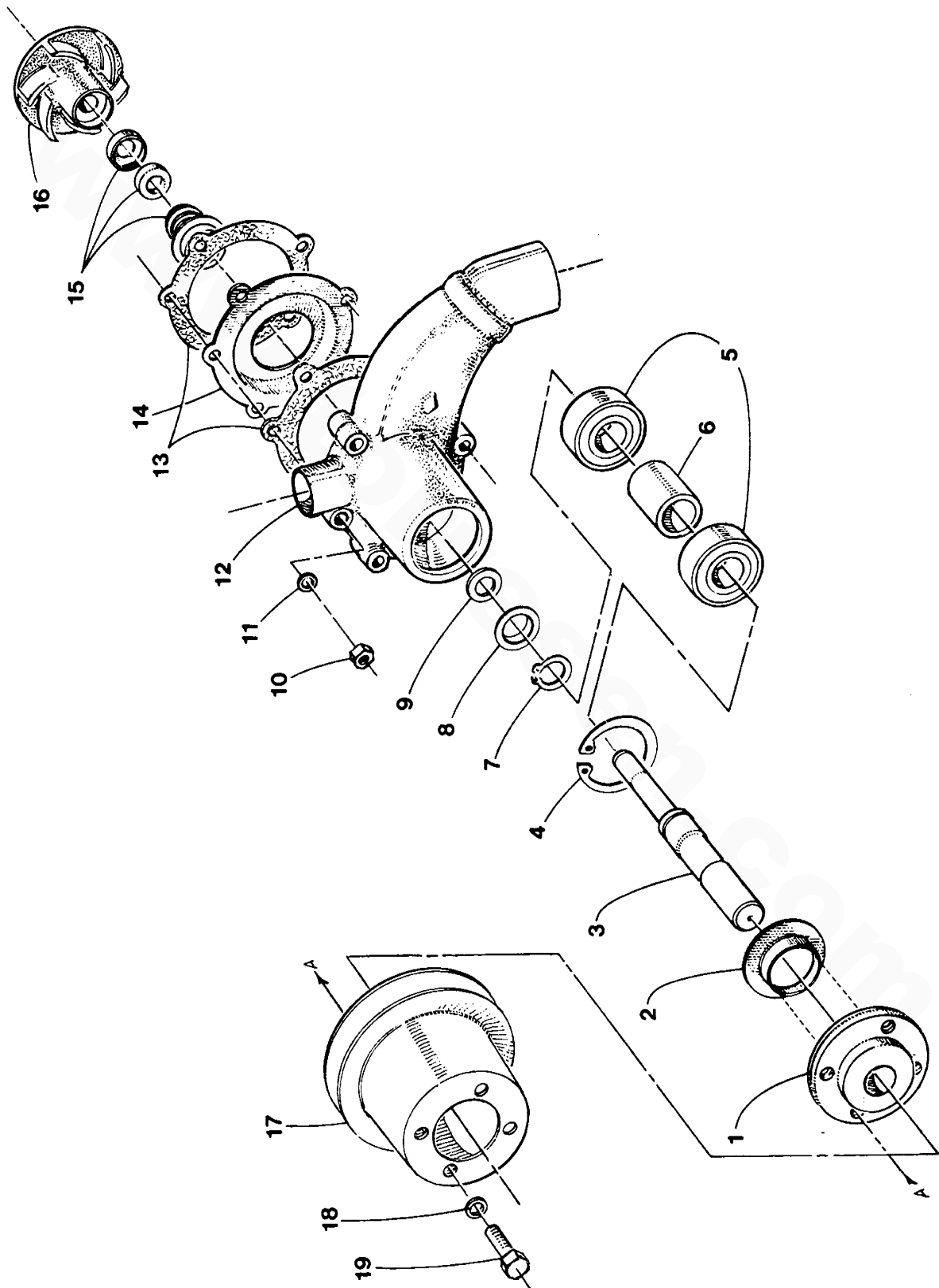

WESTERBEKE 52 - FRESH WATER PUMP

REF	PN	NAME	REMARKS	QUAN
1	24518	FLANGE	WATER PUMP PULLEY	1
2		PLATE	SEE REF 27	1
3	32382	SHAFT		1
4	24413	CIRCLIP		1
5	24568	BEARING		2
6	32380	SPACER	BEARING	1
7	24414	CIRCLIP		1
8	24479	PLATE	DUST SEAL	1
9	24481	SLINGER		1
10	31760	NUT	5/16NF	5
11	31758	LOCKWASHER	5/16	5
12	32217	PUMP	FRESH WATER	1
13	31836	GASKET		2
14	31835	PLATE		1
15	24480	SEAL		1
16	32378	IMPELLER		1
17- 1	31837	PULLEY	SINGLE GROOVE	1
17- 2	31810	PULLEY	2 GROOVE FOR 2 BELT ALTERNATOR DRIVE	1
18	31759	LOCKWASHER	5/16	4
19	31576	CAPSCREW	5/16NF X 1/2	4
20	31854	KIT	PUMP REBUILD	1

WESTERBEKE 52 - FUEL SYSTEM

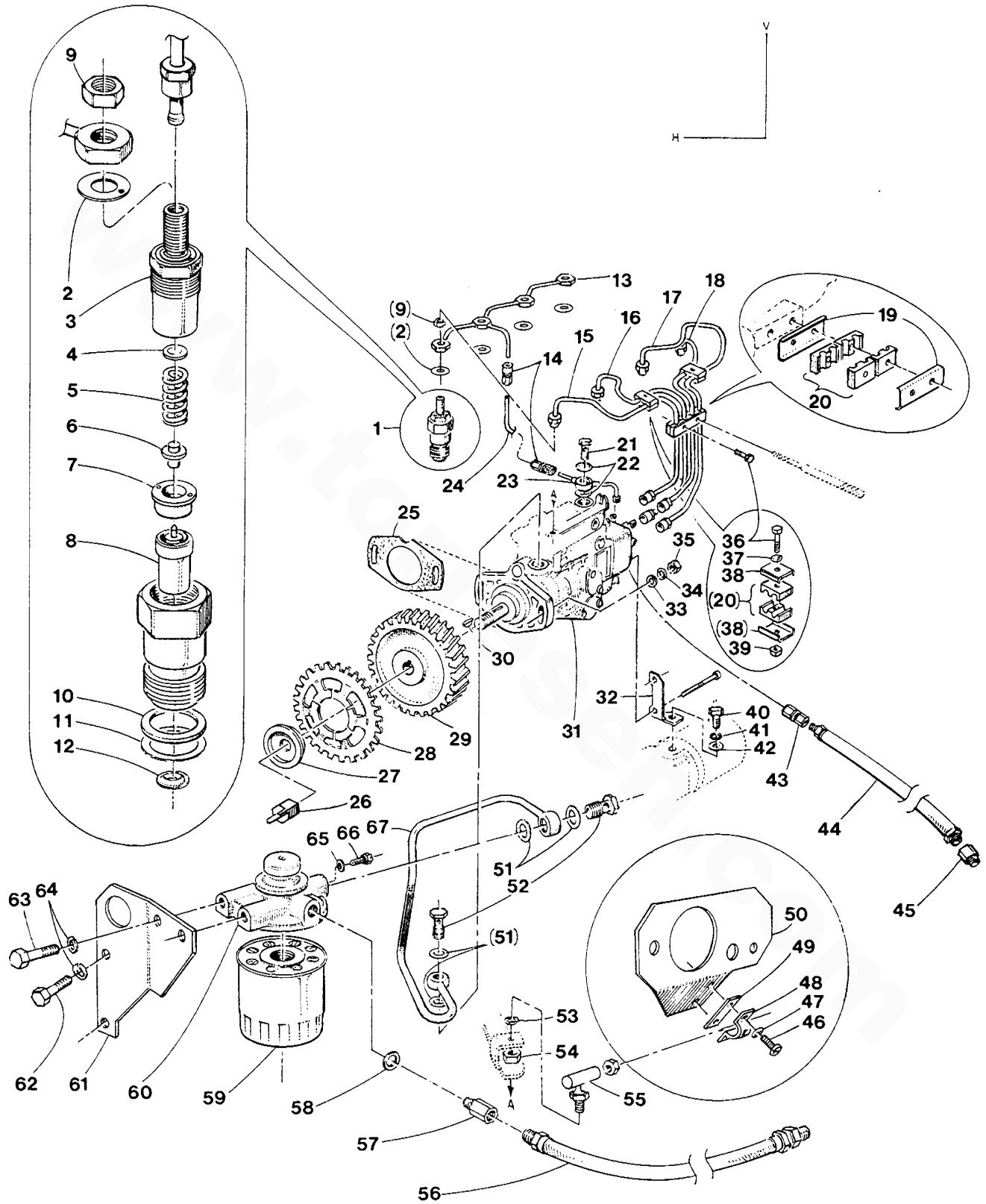

WESTERBEKE 52 - FUEL SYSTEM

REF	PN	NAME	REMARKS	QUAN
1	31019	INJECTOR	ASSEMBLY INCLUDES REF 3 THRU 9	4
2	31021	GASKET	RETURN LINE TO INJECTOR	4
3		HOLDER	SEE REF 1	
4		SHIM	SEE REF 1	
5		SPRING	SEE REF 1	
6		PUSHROD	SEE REF 1	
7		SEAT	NOZZLE SPRING-SEE REF 1	
8	24565	NOZZLE		4
9	31050	NUT	LINE TO INJECTOR	4
10	24454	WASHER	INJECTOR NOZZLE	4
11	14464	WASHER	INJECTOR	4
12	30970	WASHER		4
13	31020	LINE	INJECTOR RETURN	1
14	24600	UNION	COMPRESSION	2
15	31022	LINE	INJECTOR 1	1
16	31023	LINE	INJECTOR 2	1
17	31024	LINE	INJECTOR 3	1
18	31025	LINE	INJECTOR 4	1
19	24460	CLAMP	CHANNEL	1
20	24455	CLAMP	INJECTOR LINES	8
21	24501	BOLT	BANJO	1
22	24498	WASHER	BANJO	2
23	32370	BANJO	INJECTION PUMP OUTLET	1
24	32121	LINE	INJECTOR RETURN TO PUMP	1
25	24461	GASKET	INJECTION PUMP TO TIMING CASE	1
26	30062	TANG	SEA WATER PUMP DRIVE	1
27	31028	WASHER	INJECTION PUMP	1
28	31016	GEAR	FRICTION	1
29	31027	GEAR	INJECTION PUMP DRIVE	1
30	24515	KEY	WOODRUFF	1
31	31026	PUMP	INJECTION	1
32	30159	BRACKET	INJECTION PUMP SUPPORT	1
33	31759	WASHER	FLAT 5/16	2
34	31758	LOCKWASHER	5/16	2
35	31756	NUT	5/16NF	2
36		CAPSCREW	10-32 X 1	3
37		LOCKWASHER	10	4
38	24456	CLAMP	CHANNEL	4
39		NUT	10-32	2
40	31553	CAPSCREW	5/16NC X 3/4	1
41	31758	LOCKWASHER	5/16	1
42	31759	WASHER	FLAT 5/16	1
43	24633	CONNECTOR	BANJO TO RETURN HOSE	1
44	20950	HOSE	FUEL RETURN 24 IN LONG	1
45	15289	ADAPTER		2
46		SCREW	10-32 X 1/2	2
47		LOCKWASHER	10	2
48	13325	CLAMP	THROTTLE CABLE	1
49	13870	SHIM	THROTTLE CABLE	1

WESTERBEKE 52 - FUEL SYSTEM

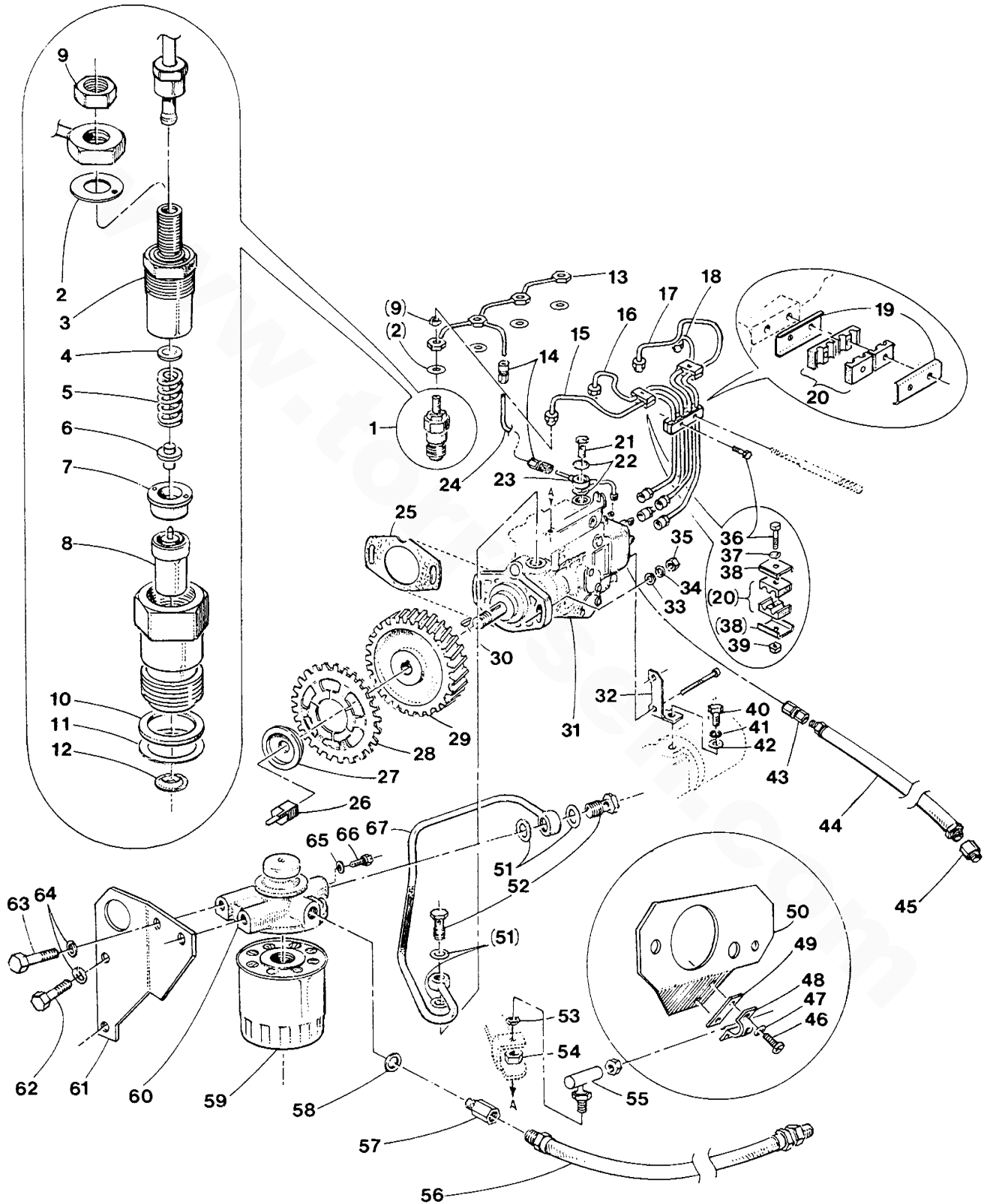

WESTERBEKE 52 - FUEL SYSTEM

REF	PN	NAME	REMARKS	QUAN
50	30136	PLATE	SILENCER AND THROTTLE CABLE	1
51	30291	WASHER	BANJO M14	4
52	30139	BOLT	BANJO	2
53		LOCKWASHER	10	1
54		NUT	11-32	1
55	19364	BALL JOINT	THROTTLE CABLE	1
56	30125	HOSE	FUEL SUPPLY 36IN LONG	1
57	30766	ADAPTER	FUEL FILTER TO 1/8NPT	1
58	30290	WASHER	BANJO M12	1
59	24363	ELEMENT	FUEL FILTER	1
60	24549	FILTER	FUEL WITH PRIMING PUMP	1
61	30155	BRACKET	FUEL FILTER	1
62	31631	CAPSCREW	3/8NF X 1-1/4	1
63	31630	CAPSCREW	3/8NF X 1	3
64	31764	LOCKWASHER	3/8	4
65	17567	WASHER	BLEED SCREW	1
66		SCREW	BLEED	1
67	30755	LINE	FUEL FILTER TO INJECTION PUMP	1

WESTERBEKE 52 - FUEL INJECTION PUMP

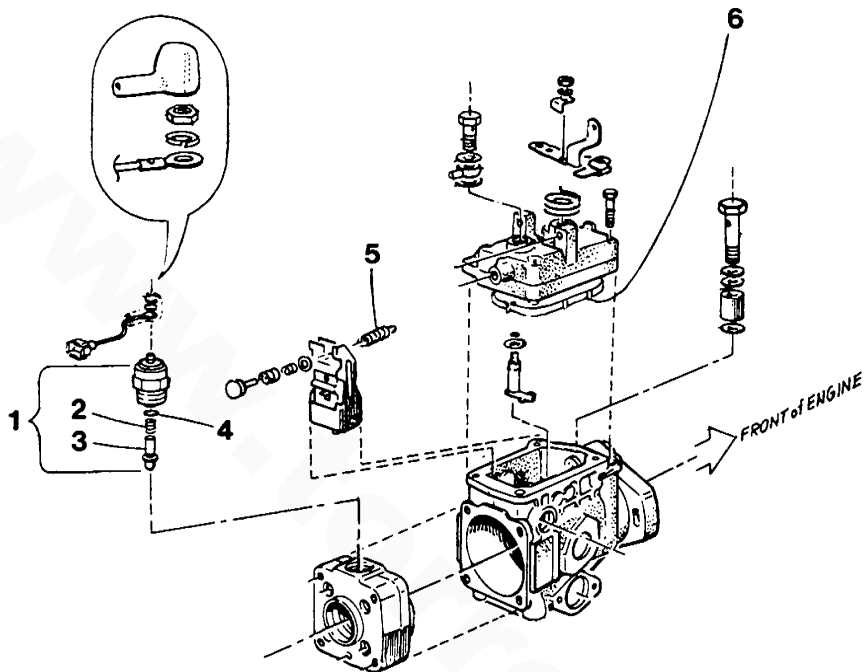

WESTERBEKE 52 - FUEL INJECTION PUMP

REF	PN	NAME	REMARKS	QUAN
1	24338	SOLENOID	FUEL SHUT-OFF INCLUDES REF 2 AND 3	1
2	32131	SPRING	FUEL SOLENOID PLUNGER	1
3	32114	PLUNGER	FUEL SOLENOID	1
4	24339	C-RING	FUEL SOLENOID	1
5 - 1	31049	SPRING	GOVERNOR-MARINE ENGINE	1
5 - 2	24585	SPRING	GOVERNOR-GENERATOR	1
6	24542	GASKET	PUMP GOVERNOR COVER	1

www.torresen.com

WESTERBEKE PRIMARY FUEL FILTER

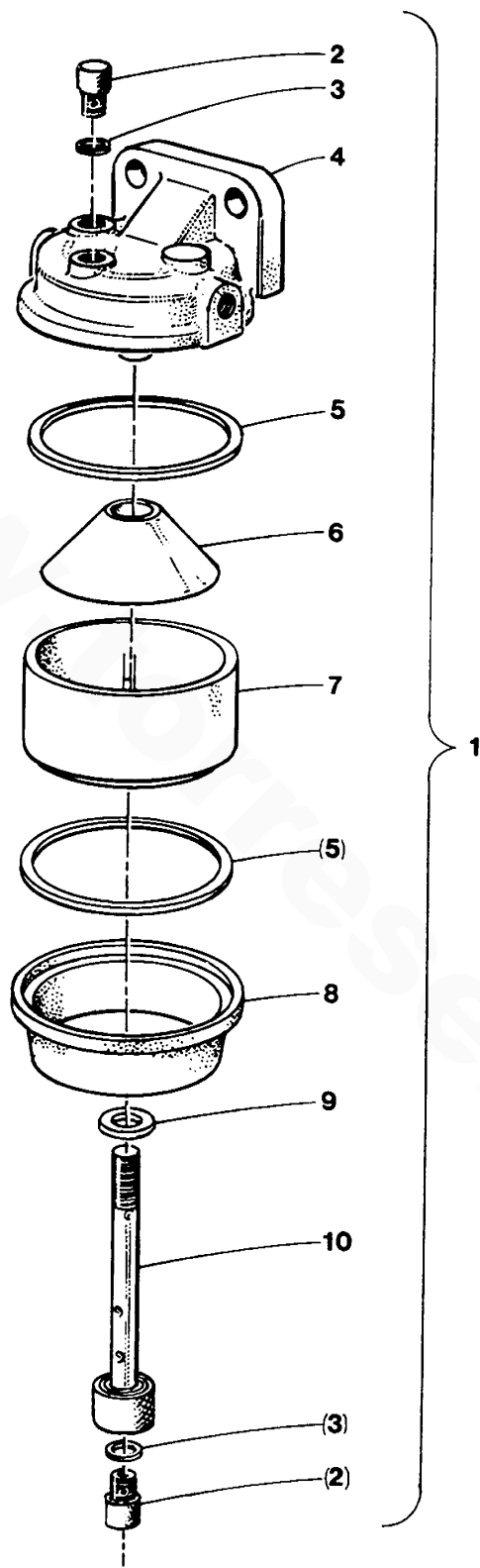

WESTERBEKE PRIMARY FUEL FILTER

REF	PN	NAME	REMARKS	QUAN
1	24985	FILTER	PRIMARY FUEL - WATER SEPARATOR	1
2	31176	SCREW	VENT AND DRAIN	2
3	31175	SEAL	VENT AND DRAIN SCREW	2
4	31183	HEAD	FILTER	1
5	31176	GASKET		2
6	31181	CONE		1
7	31180	BODY		1
8	31177	BOWL	SEDIMENT	1
9	31179	SEAL	BOWL SCREW	1
10	31182	SCREW	BOWL	1

www.torresen.com

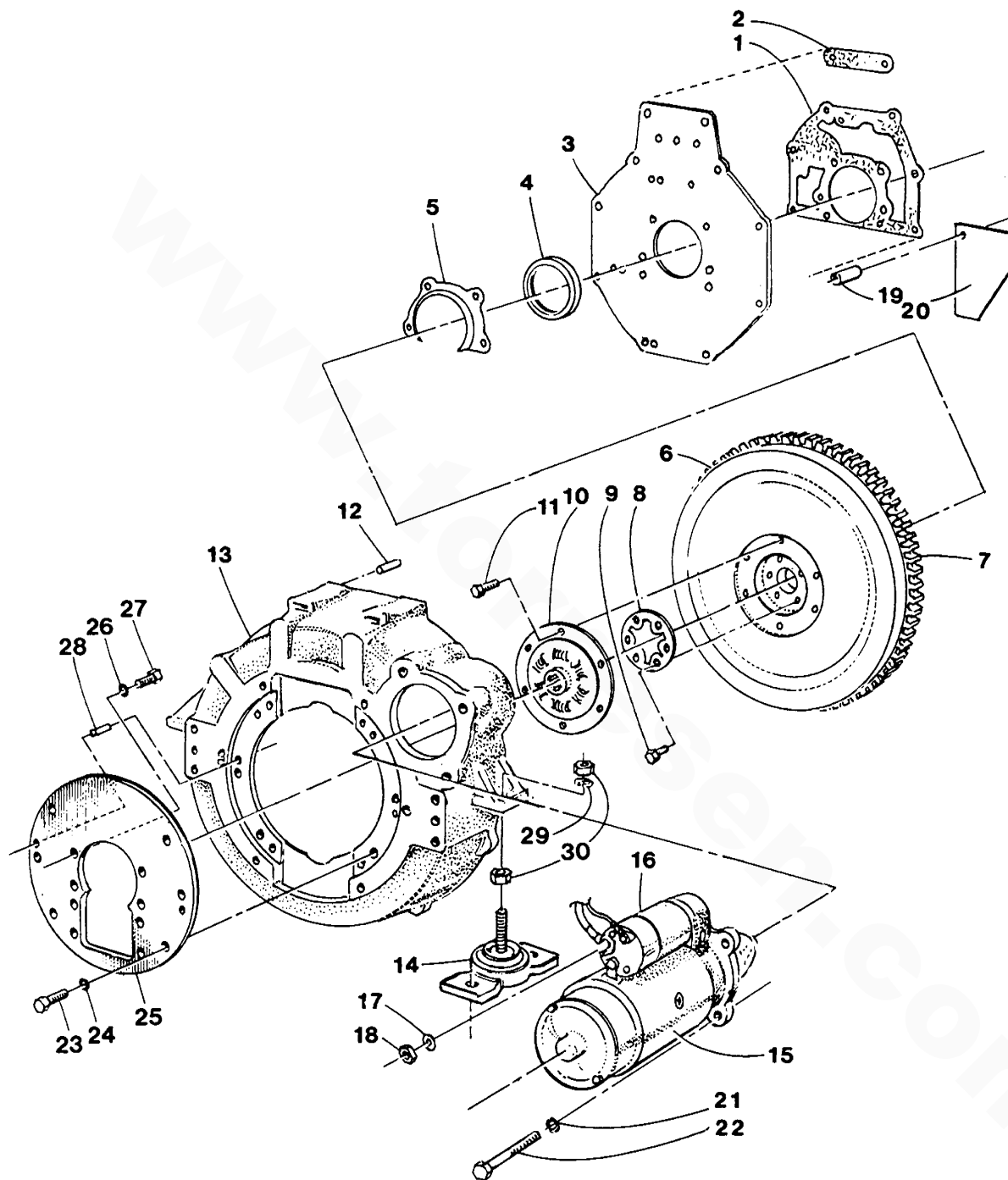

WESTERBEKE 30-40-50-52-58-60 - COMMON BACK END

REF	PN	NAME	REMARKS	QUAN
		NOTE	ABSENCE OF A LISTING INDICATE NO PART USED ON THAT MODEL	
1- 1	30130	GASKET	BACKPLATE TO BLOCK-W30,W50	1
1- 2	17583	GASKET	BACKPLATE TO BLOCK-W60	1
2- 1	23174	GASKET	BACKPLATE TO BLOCK-UPPER-W50	1
2- 2	17742	GASKET	BACKPLATE TO BLOCK-UPPER-W60	1
3- 1	23788	BACKPLATE	W30,W50,W60	1
3- 2	23948	BACKPLATE	W40,W52,W58	1
4	16519	SEAL	OIL-W50,W60	1
5	23173	RETAINER	OIL SEAL TO BACKPLATE-W50	1
6- 1	24722	FLYWHEEL	WITH RING GEAR-W30	1
6- 2	24723	FLYWHEEL	WITH RING GEAR-W40	1
6- 3	24724	FLYWHEEL	WITH RING GEAR-W50	1
6- 4	24725	FLYWHEEL	WITH RING GEAR-W52,W58	1
6- 5	24726	FLYWHEEL	WITH RING GEAP-W60	1
7	23579	GEAR	RING	1
8- 1	24142	TABWASHER	W30	1
8- 2	14720	TABWASHER	W40	1
8- 3	13072	TABWASHER	W50,W60	1
8- 4	31166	TABWASHER	W52,W58	1
9- 1	24124	NUT	FLYWHEEL-W30	6
9- 2		BOLT	FLYWHEEL-W40-7/16NF X 1-1/8 GR-5	5
9- 3	31684	BOLT	FLYWHEEL-W50-7/16NF X 2 GR-5	5
9- 4	24411	BOLT	FLYWHEEL-W52,W58	6
9- 5	17727	BOLT	FLYWHEEL-W60	6
10- 1	11618	DAMPER	HYDRAULIC,HBW20,HBW220	1
10- 2	19398	DAMPER	HBW10,50,100,150,150V	1
10- 3	30940	DAMPER	BW7	1
11	24770	CAPSCREW	DAMPER TO FLYWHEEL	5
12	19039	DOWEL	HOUSING TO BACKPLATE	2
13- 1	32260	HOUSING	FLYWHEEL-MOUNT 18-20-22.5IN CENTERS	1
13- 2	23608	HOUSING	FLYWHEEL-TO JUNE 82-OBS-USE 32260	1
14- 1	32013	ISOLATOR	REAR-W30,W40,W50,W52	2
14- 2	11687	ISOLATOR	REAR-W58,W60	2
15	16762	MOTOR	STARTER INCLUDING SOLENOID	1
16	23338	SOLENOID	STARTER MOTOR	1
17	16502	LOCKWASHER	BRASS-SOLENOID BATTERY TERMINAL	1
18	16091	NUT	BRASS-SOLENOID BATTERY TERMINAL	1
19	21722	SPACER	BACKPLATE TO CIRCUIT BREAKER BRACKET	2
20	24065	BRACKET	CIRCUIT BREAKER	1

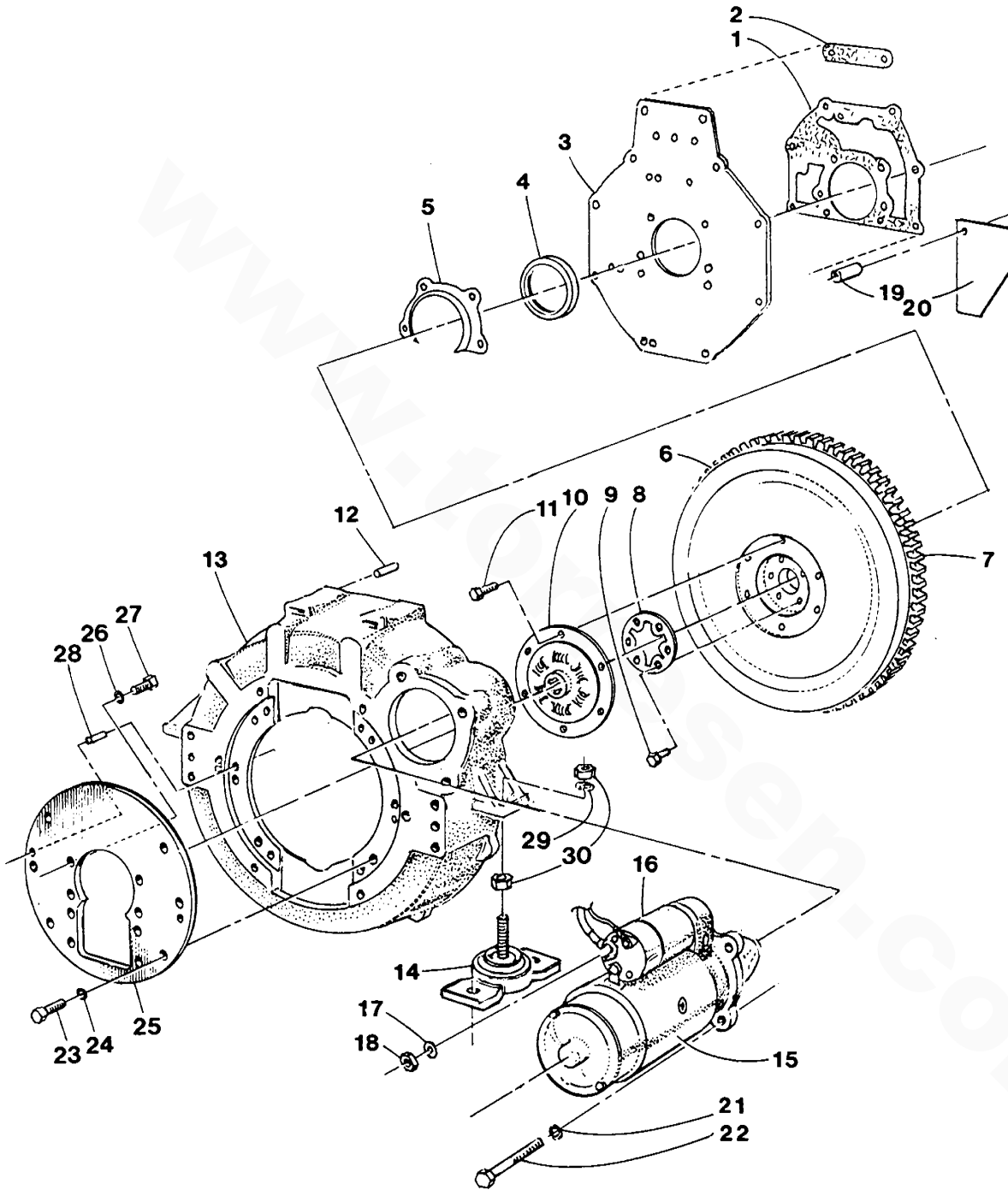

WESTERBEKE 30-40-50-52-58-60 - COMMON BACK END

REF	PN	NAME	REMARKS	QUAN
21	31764	LOCKWASHER	3/8	3
22	31606	CAPSCREW	3/8NC X 1-1/4	3
23	31655	CAPSCREW	7/16NC X 1	6
24	31770	LOCKWASHER	7/16	6
25- 1	31267	ADAPTER	HBW10,50,100,150,BW7	1
25- 2	30063	ADAPTER	HBW150V	1
25- 3	31256	ADAPTER	HBW20,HBW220	1
25- 4	19309	ADAPTER	HBW10,50,100,150-TO NOV 81-NO DOWELS	1
26- 1	31788	LOCKWASHER	M 8 DIN 137B-HBW-BW	6
26- 2	31790	LOCKWASHER	M 10 DIN 137B-HBW150V	6
27- 1	20650	CAPSCREW	M 8 X 19 DIN 933-HBW10,50,100,150	6
27- 2	31452	CAPSCREW	M8 X 22 DIN 933-BW7	6
27- 3	13630	CAPSCREW	M 8 X 25 DIN 933-HBW20,HBW220	6
27- 4	13429	CAPSCREW	M 10 X 25 DIN 933-HBW150V	6
28	19039	DOWEL	ALIGN 31267 ADAPTER TO HOUSING	2
29	31827	LOCKWASHER	5/8	2
30	31826	NUT	5/8NF JAM	6

WESTERBEKE 52 - ALTERNATOR MOUNT

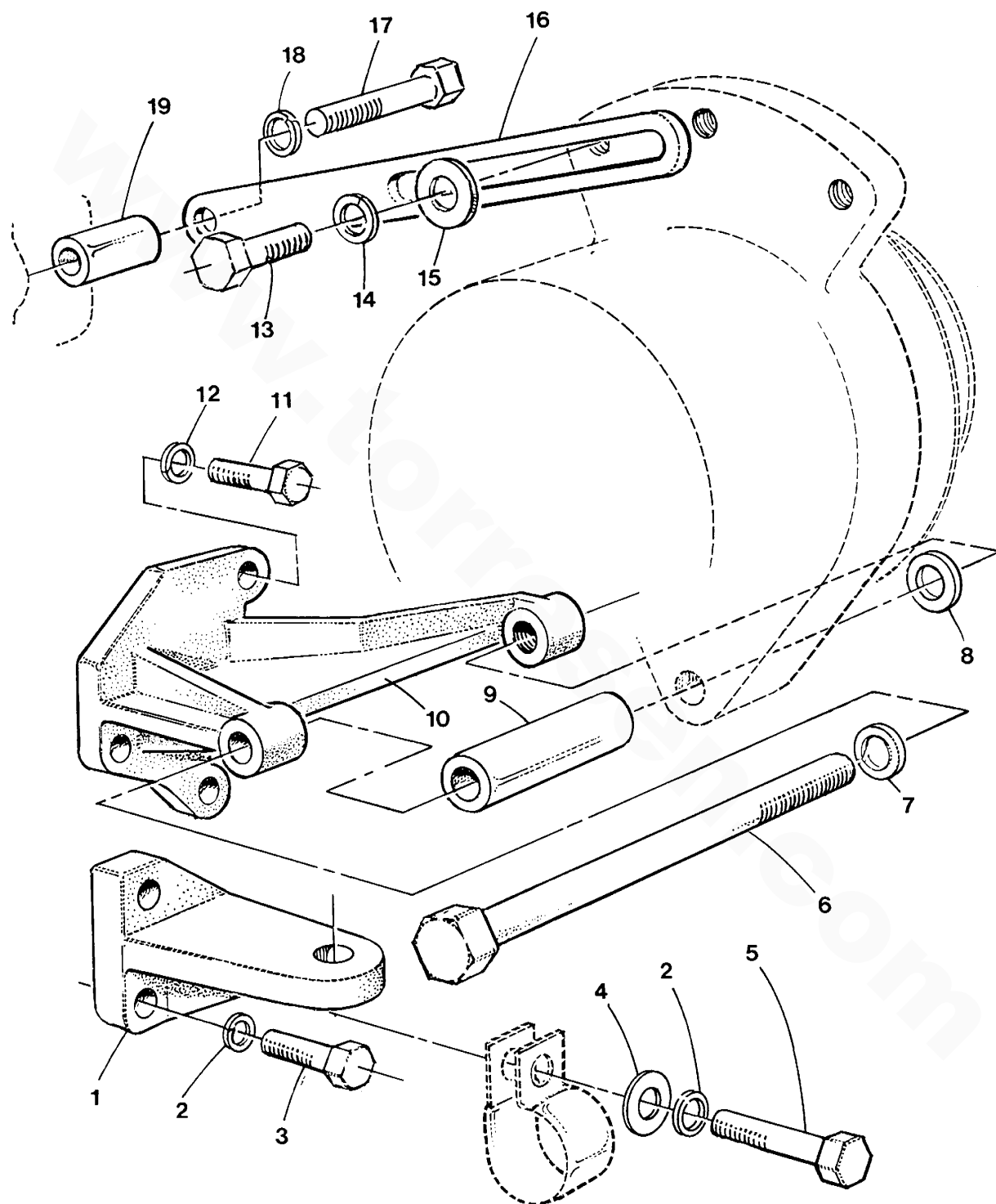

WESTERBEKE 52 - ALTERNATOR MOUNT

REF	PN	NAME	REMARKS	QUAN
1	23954	MOUNT	FRONT RIGHT	1
2	31770	LOCKWASHER	7/16	3
3	31681	CAPSCREW	7/16NF X 1-1/4	2
4	31771	WASHER	FLAT 7/16	1
5	31682	CAPSCREW	7/16NF X 1-1/2	1
6- 1	31722	CAPSCREW	1/2NC X 5-1/4 BRACKET 30128	1
6- 2	31622	CAPSCREW	3/8NC X 5-1/4 BRACKET 31170	1
7- 1	31776	LOCKWASHER	1/2	1
7- 2	31764	LOCKWASHER	3/8	1
8- 1	30168	SPACER	55AMP	1
8- 2	31159	SPACER	120AMP	1
9- 1	30182	SPACER	55AMP	1
9- 2	31169	SPACER	90AMP	1
10- 1	30128	BRACKET	ALTERNATOR 55AMP	1
10- 2	31170	BRACKET	ALTERNATOR 90AMP	1
11	31631	CAPSCREW	3/8NF X 1-1/4	3
12	31764	LOCKWASHER	3/8	3
13	31554	CAPSCREW	5/16NC X 7/8	1
14	31758	LOCKWASHER	5/16	1
15	31759	WASHER	FLAT 5/16	1
16	1112F	STRAP	ALTERNATOR ADJUSTING	1
17	31584	CAPSCREW	5/16NF X 2	1
18	31758	LOCKWASHER	5/16	1
19	31318	SPACER		1

WESTERBEKE 52 - EXTRA 55 AMP ALTERNATOR

www.torrsen.com

WESTERBEKE 52 - EXTRA 55 AMP ALTERNATOR

REF	PN	NAME	REMARKS	QUAN
1	31210	BRACKET	ALTERNATOR	1
2	31632	CAPSCREW	3/8NF X 1-1/2	2
3	31764	LOCKWASHER	3/8	2
4	24684	ALTERNATOR	55AMP 12VDC NEG GROUND WITH REGULATOR	1
5	11548	PULLEY	ALTERNATOR DRIVE	1
6	31710	CAPSCREW	1/2NC X 2-1/4	1
7	31776	LOCKWASHER	1/2	1
8	11195	BELT	ALTERNATOR DRIVE	1
9	12245	STRAP	ALTERNATOR ADJUSTING	1
10	21722	SPACER	STRAP TO ALTERNATOR	1
11	31556	CAPSCREW	5/16NC X 1-1/4	1
12	31758	LOCKWASHER	5/16	2
13	31759	WASHER	FLAT 5/16	2
14	31592	CAPSCREW	5/16NF X 4	1

ELECTRICAL SYSTEM-MARINE ENGINE-ACTIVATION BY KEYSWITCH

SCHEMATIC DIAGRAM

WIRING DIAGRAM

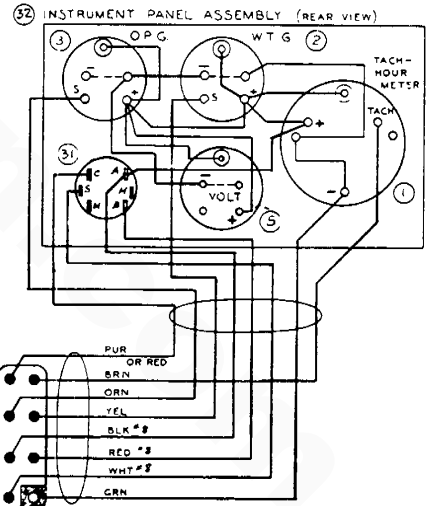
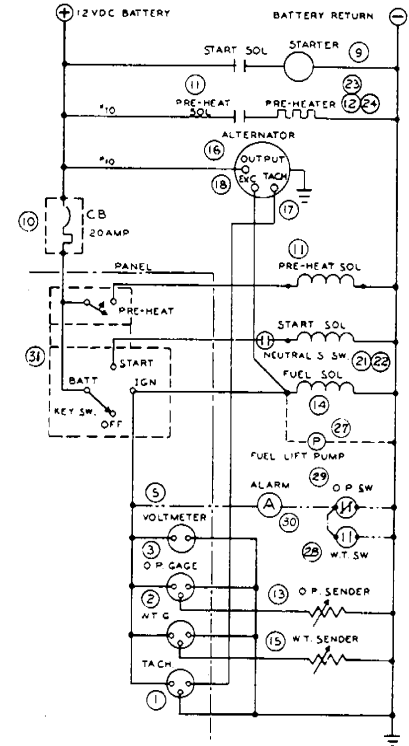
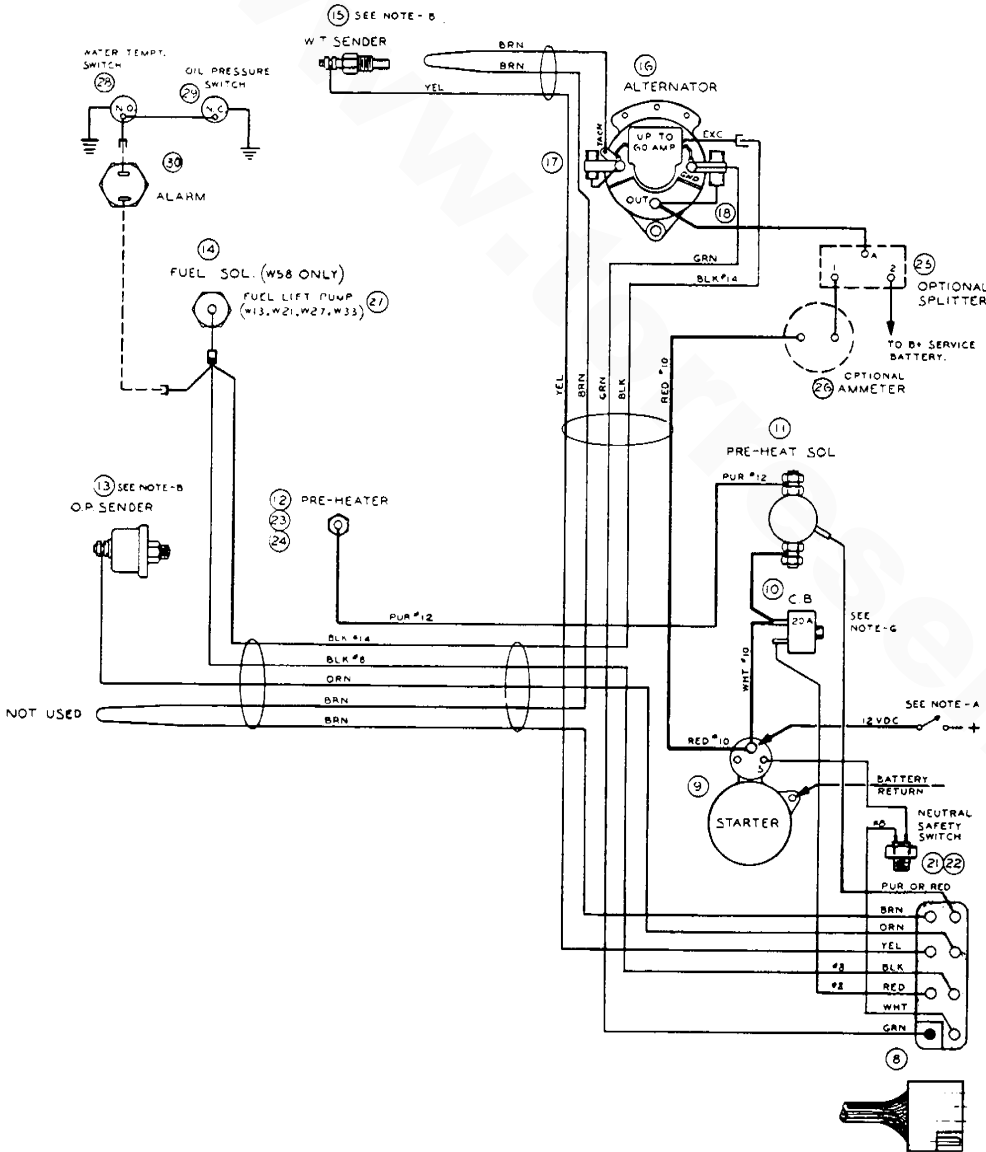

ELECTRICAL SYSTEM-MARINE ENGINE-ACTIVATION BY KEYSWITCH

REF	PN	NAME	REMARKS	QJAN
1	11917	METER	TACHOMETER-HOURMETER	1
2	11545	GAUGE	WATER TEMPERATURE	1
3	24133	GAUGE	OIL PRESSURE 0-100 PSI	1
4- 1	11957	SWITCH	PUSHBUTTON PRE-HEAT	1
4- 2	19031	CAP	SWITCH PROTECTIVE COVER	1
5	23190	VOLTMETER	12VDC NEG GROUND	1
7	30148	CABLE	PANEL	1
8- 1	31127	HARNESS	ENGINE WIRING-W30,W40,W50	1
8- 2	31128	HARNESS	ENGINE WIRING-W52	1
8- 3	31129	HARNESS	ENGINE WIRING-W58	1
9- 1	16762	MOTOR	STARTER	1
9- 2	23338	SOLENOID	START-FOR 16762 STARTER	1
10	24683	BREAKER	CIRCUIT-20 AMP	1
11	24639	SOLENOID	PRE-HEAT	1
12- 1	24353	GLOWPLUG	W52,W58	4
12- 2	24354	STRAP	GLOWPLUG CONNECTING-W58	3
12- 3	32366	WIRE	GLOWPLUG CONNECTING-W52	1
13	24132	SENDER	OIL PRESSURE 0-100 PSI	1
14	24338	SOLENOID	FUEL SHUT-OFF-W52,W58	1
15	23571	SENDER	WATER TEMPERATURE 1/8 NPT	1
16- 1	24684	ALTERNATOR	55AMP NEG GROUND WITH REGULATOR	1
16- 2	11548	PULLEY	ALTERNATOR DRIVE	1
16- 3	24579	REGULATOR	55 AMP	1
16- 4	24580	GASKET	ALTERNATOR TO REGULATOR	1
16- 5	11677	ALTERNATOR	120AMP-12VDC	1
16- 6	11682	REGULATOR	120AMP	1
16- 7	23086	CABLE	REGULATOR 11682	1
16- 8	11675	CABLE	ALTERNATOR TO REGULATOR	1
16- 9	11676	RESISTOR	75 OHM	1
16-10	11674	PULLEY	ALTERNATOR DRIVE-W40-50-80-120	1
16-11	22219	PULLEY	ALTERNATOR DRIVE-W58	1
16-12	31109	PULLEY	ALTERNATOR DRIVE-W52	1
16-13	11231	DIAGRAM	WIRING 120AMP ALTERNATOR	1
16-14	23603	DIAGRAM	WIRING 120AMP REGULATOR	1
16-15	30735	ALTERNATOR	90AMP-12VDC	1
16-16	31168	PULLEY	ALTERNATOR DRIVE-W52	1
16-17	31201	DIAGRAM	WIRING 90AMP ALTERNATOR	1
17	12959	KIT	ALTERNATOR MOD FOR ELEC TACHOMETER	1
18	11532	KIT	ALTERNATOR SUPPRESSION	1
21	23433	SWITCH	NEUTRAL SAFETY WARNER TRANSMISSION	1
22	23309	SWITCH	NEUTRAL SAFETY PARAGON TRANSMISSION P200	1
23	11530	PREHEATER	MANIFOLD W40	1
24- 1	14529	GLOWPLUG	W30,W50	4
24- 2	14494	WIRE	GLOWPLUG CONNECTING 4.25 LONG-W30,W50	AR
25	20654	SPLITTER	ALTERNATOR OUTPUT-OPTIONAL	1

ELECTRICAL SYSTEM-MARINE ENGINE-ACTIVATION BY KEYSWITCH

WIRING DIAGRAM

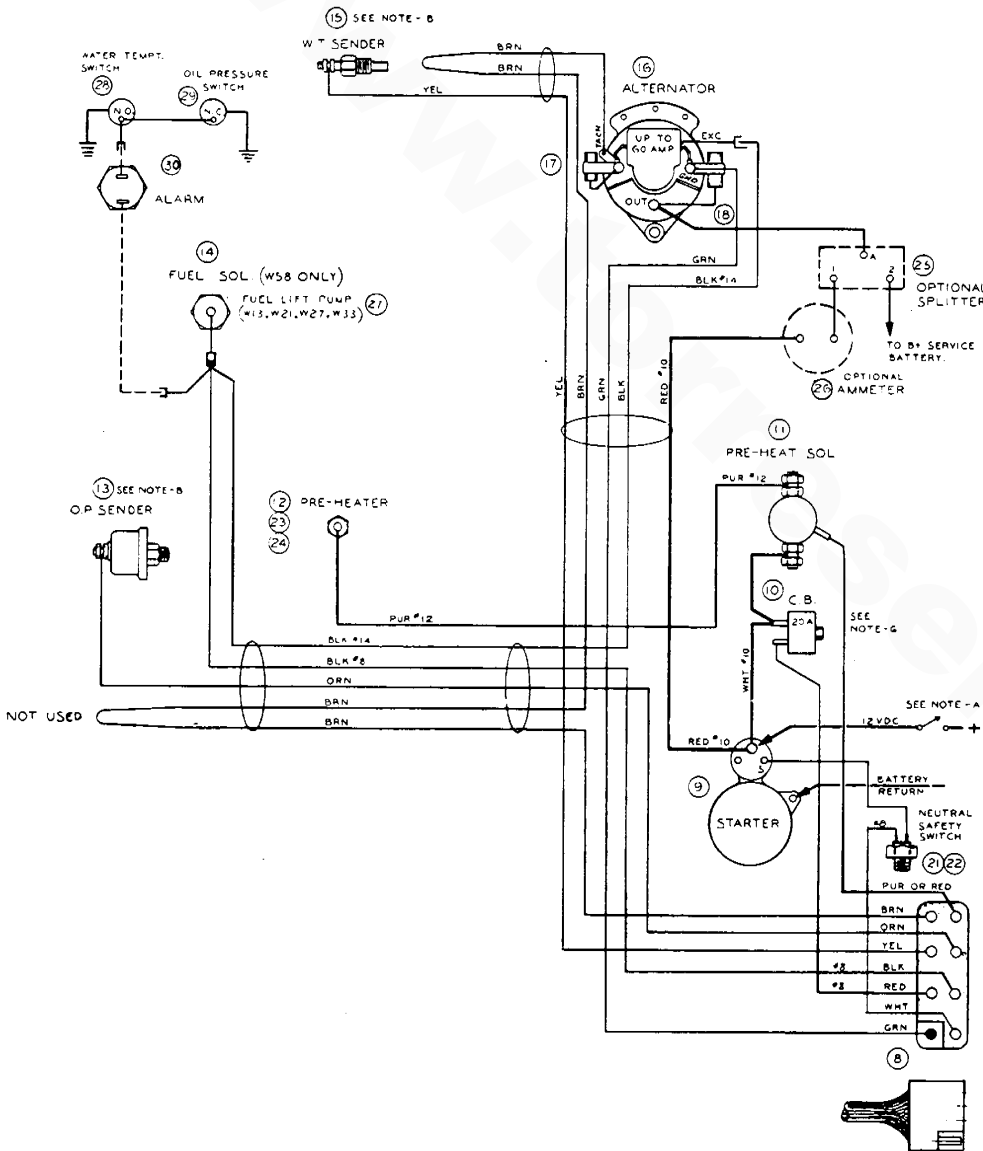

SCHEMATIC DIAGRAM

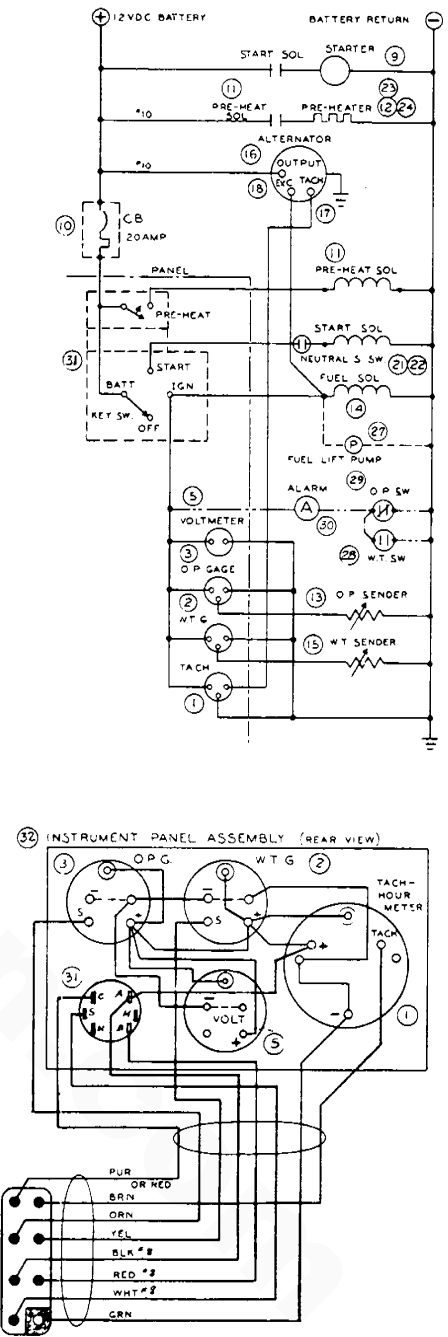

ELECTRICAL SYSTEM-MARINE ENGINE-ACTIVATION BY KEYSWITCH

REF	PN	NAME	REMARKS	QUAN
26	11581	AMMETER	60-0-60-OPTIONAL	1
28	30125	SWITCH	WATER TEMPERATURE-NO-ALARM	1
29	30944	SWITCH	OIL PRESSURE-NC-ALARM	1
30	13355	ALARM	BUZZER	1
31	24777	KEYSWITCH	OFF-ON-START-PUSH TO PRE-HEAT	1
32	24880	PANEL	INSTRUMENT-COMPLETE	1
33	24751	PANEL	INSTRUMENT-PLATE ONLY	1
50	31086	BOOT	ALTERNATOR OUTPUT TERMINAL	1
51- 1	30065	CONDUIT	FLEX-GARD 0.35ID-INCHES REQD	AR
51- 2	30066	CONDUIT	FLEX-GARD 0.50ID-INCHES REQD	AR
51- 3	30067	CONDUIT	FLEX-GARD 0.75ID-INCHES REQD	AR

WESTERBEKE MARINE INSTRUMENT PANEL

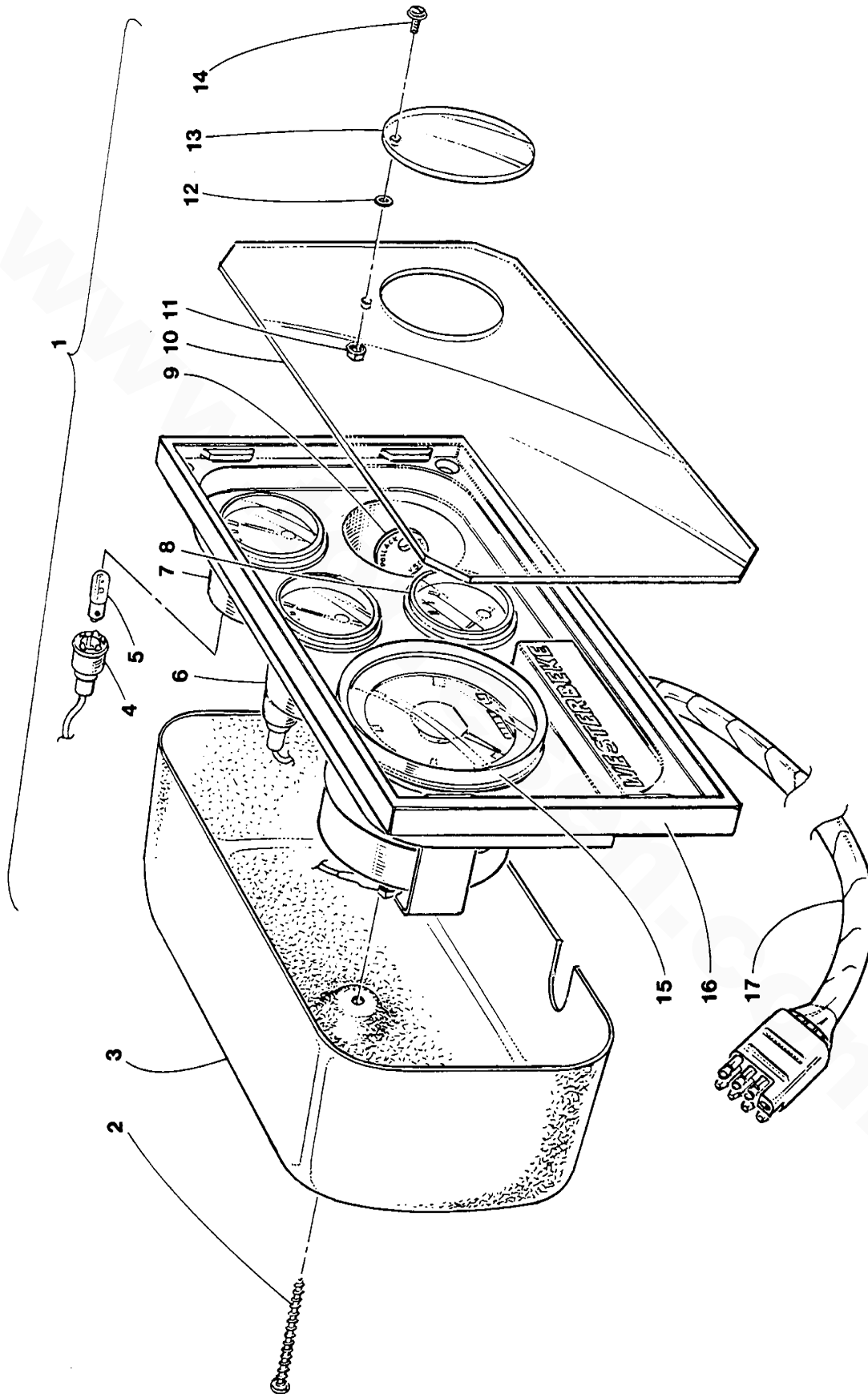

WESTERBEKE MARINE INSTRUMENT PANEL

REF	PN	NAME	REMARKS	QUAN
1	24880	PANEL	INSTRUMENT-ASSEMBLY	1
2	30913	SCREW		1
3	30119	COVER	PANEL REAR	1
4	24946	HOLDER	LAMP	4
5	24947	LAMP	INSTRUMENT METERS	4
6	11545	METER	WATER TEMPERATURE	1
7	24133	METER	OIL PRESSURE 0-100 PSI	1
8	23090	VOLTMETER	12 VDC NEG GROUND	1
9	24777	SWITCH	KEY	1
10	24994	COVER	FACEPLATE WINDOW	1
11	30003	NUT	NYLON LOCKING 6-32	1
12	30002	SPACER	NYLON	1
13	24996	WINDOW	KEYSWITCH COVER	1
14	30001	SCREW	NYLON 6-32 X 1/2 WASHER HEAD	1
15	11917	METER	TACHOMETER-HOUR	1
16	24751	PANEL	FACEPLATE	1
17	30148	CABLE	PANEL TO ENGINE	1
18	24999	DRAWING	TEMPLATE TO INSTALL PANEL	1

GENERATOR CONTROL-MANUAL START DISCONNECT-TOGGLE SWITCHES

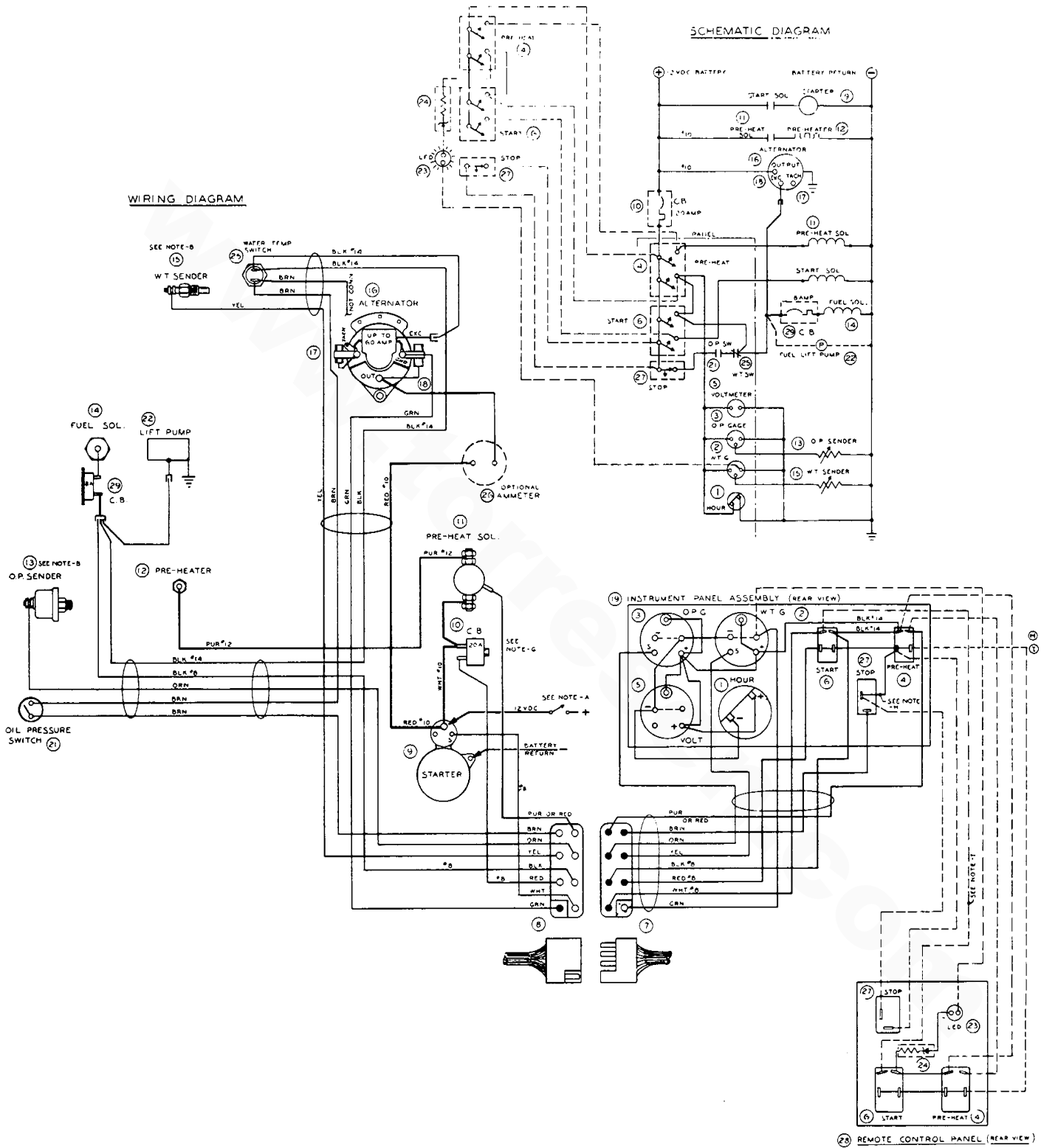

GENERATOR CONTROL-MANUAL START DISCONNECT-TOGGLE SWITCHES

REF	PN	NAME	REMARKS	QJAN
1	12892	METER	HOUR	1
2	11545	GAUGE	WATER TEMPERATURE	1
3	24133	GAUGE	OIL PRESSURE 0-100 PSI	1
4	24732	SWITCH	PRE-HEAT	1
5	23090	VOLTMETER	12VDC NEG GROUND	1
6	24732	SWITCH	START	1
7	30147	CABLE	PANEL	1
8- 1	31137	HARNESS	ENGINE-W52 15KW	1
8- 2	31139	HARNESS	ENGINE-W58 20KW	1
9- 1	23953	MOTOR	STARTER	1
9- 2	23338	SOLENOID	START-FOR 23953 STARTER	1
10	24683	BREAKER	CIRCUIT-20 AMP	1
11	24639	SOLENOID	PRE-HEAT	1
12- 1	24353	GLOWPLUG	W52 15KW-W58 20KW	4
12- 2	24354	STRAP	GLOWPLUG CONNECTING-W58-20KW	1
12- 3	32366	WIRE	GLOWPLUG CONNECTING-W52-15KW	1
13	24132	SENDER	OIL PRESSURE 0-100 PSI	1
14	24338	SOLENOID	FUEL SHUT-OFF-W52,W58	1
15	23571	SENDER	WATER TEMPERATURE 1/2 NPT	1
16- 1	24684	ALTERNATOR	55 AMP NEG GROUND WITH REGULATOR	1
16- 2	11548	PULLEY	ALTERNATOR DRIVE	1
16- 3	24579	REGULATOR		1
16- 4	24580	GASKET	ALTERNATOR TO REGULATOR	1
17	12959	KIT	ALTERNATOR MOD FOR ELEC TACHOMETER	1
18	11532	KIT	ALTERNATOR SUPPRESSION	1
19- 1	24873	PANEL	COMPLETE-15KW,20KW	1
19- 2	30781	PANEL	COMPLETE-15-20KW YD INCL VOLT REGULATOR	1
20	24751	PANEL	PLATE ONLY	1
21	32364	SWITCH	OIL PRESSURE-NO	1
22	24831	PUMP	ELECTRIC FUEL LIFT	1
23	15243	LED	REMOTE CONTROL PANEL	1
24- 1	13723	RESISTOR	REMOTE CONTROL PANEL	1
24- 2	13724	DIODE	REMOTE CONTROL PANEL	1
25	30096	SWITCH	WATER TEMPERATURE-NC	1
26	11581	AMMETER	60-0-60-OPTIONAL	1
27	24731	SWITCH	STOP	1
28- 1	24943	PANEL	REMOTE CONTROL-OPTIONAL	1
28- 2	24918	PLATE	REMOTE CONTROL PANEL	1
29	24762	BREAKER	CIRCUIT-8 AMP	1
50	24968	DECAL	GENERATOR OPERATING INSTRUCTIONS	1
51	31086	BOOT	ALTERNATOR OUTPUT TERMINAL	1
52- 1	30065	CONDUIT	FLEX-GARD 0.35ID-INCHES REQD	AR
52- 2	30066	CONDUIT	FLEX-GARD 0.50ID-INCHES REQD	AR
52- 3	30067	CONDUIT	FLEX-GARD 0.75ID-INCHES REQD	AR

WESTERBEKE GENERATOR CONTROL PANEL

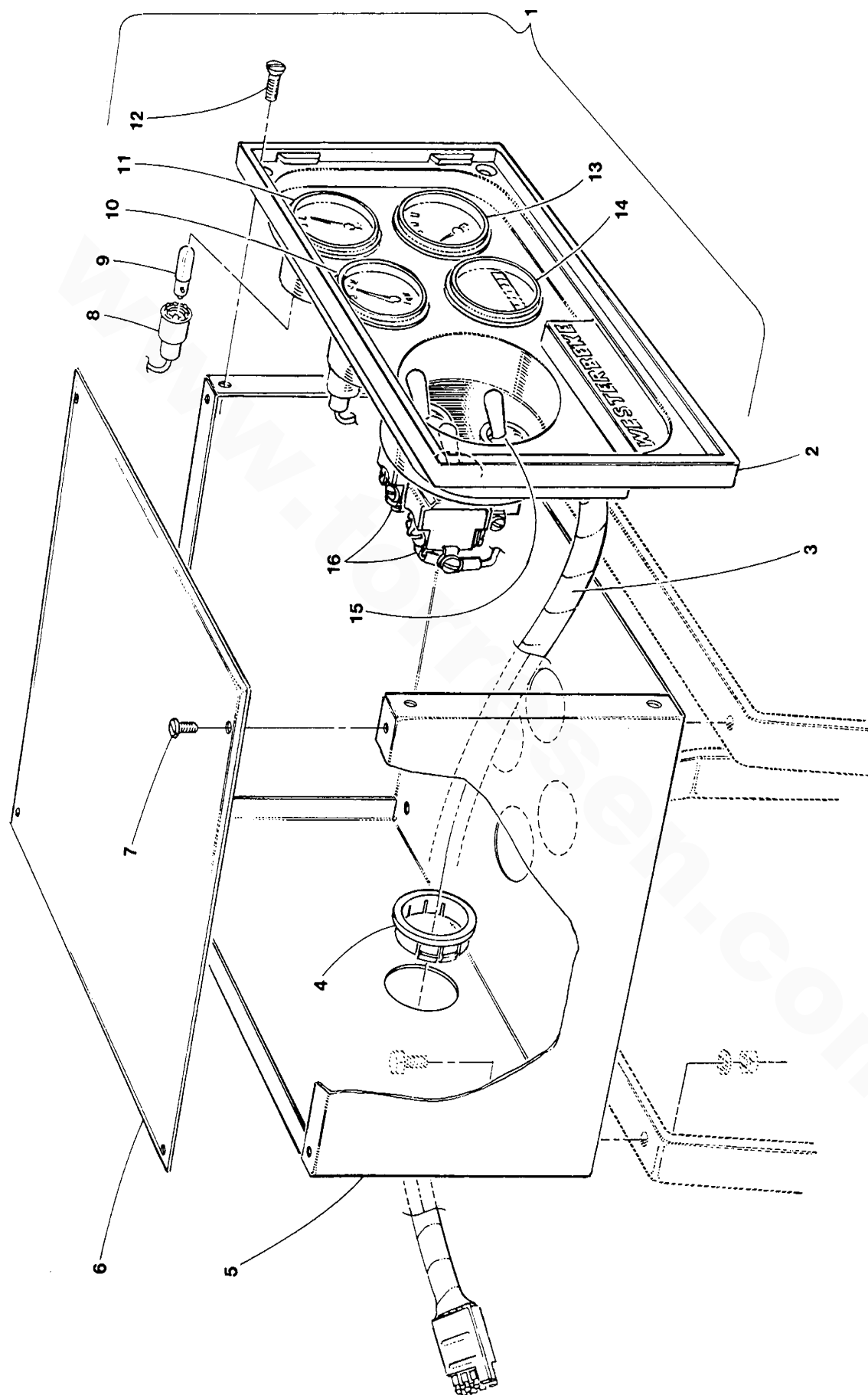

WESTERBEKE GENERATOR CONTROL PANEL

REF	PN	NAME	REMARKS	QUAN
1	24873	PANEL	ASSEMBLY INCLUDING BOX	1
2	24751	PANEL	FACEPLATE	1
3	30147	CABLE	PANEL TO ENGINE	1
4	23535	RUSHING	1-3/4 HOLE	3
5	24794	BOX	PANEL	1
6	24795	COVER	PANEL BOX	1
7		SCREW	8-32 X 3/8 RH SS	4
8	24946	HOLDER	LAMP	3
9	24947	LAMP	INSTRUMENT METERS	3
10	11545	METER	WATER TEMPERATURE	1
11	24133	METER	OIL PRESSURE 0-100 PSI	1
12		SCREW	8-32 X 3/8 OVAL HD SS	4
13	23590	VOLTMETER	12 VDC NEG GROUND	1
14	12892	METER	HOUR	1
15	24731	SWITCH	STOP	1
16	24732	SWITCH	START-PREHEAT	2
17	32031	COVER	PANEL BOX WHEN FACEPLATE REMOTE MOUNTED	1

WESTERBEKE 52 - TRANSMISSION - COUPLING

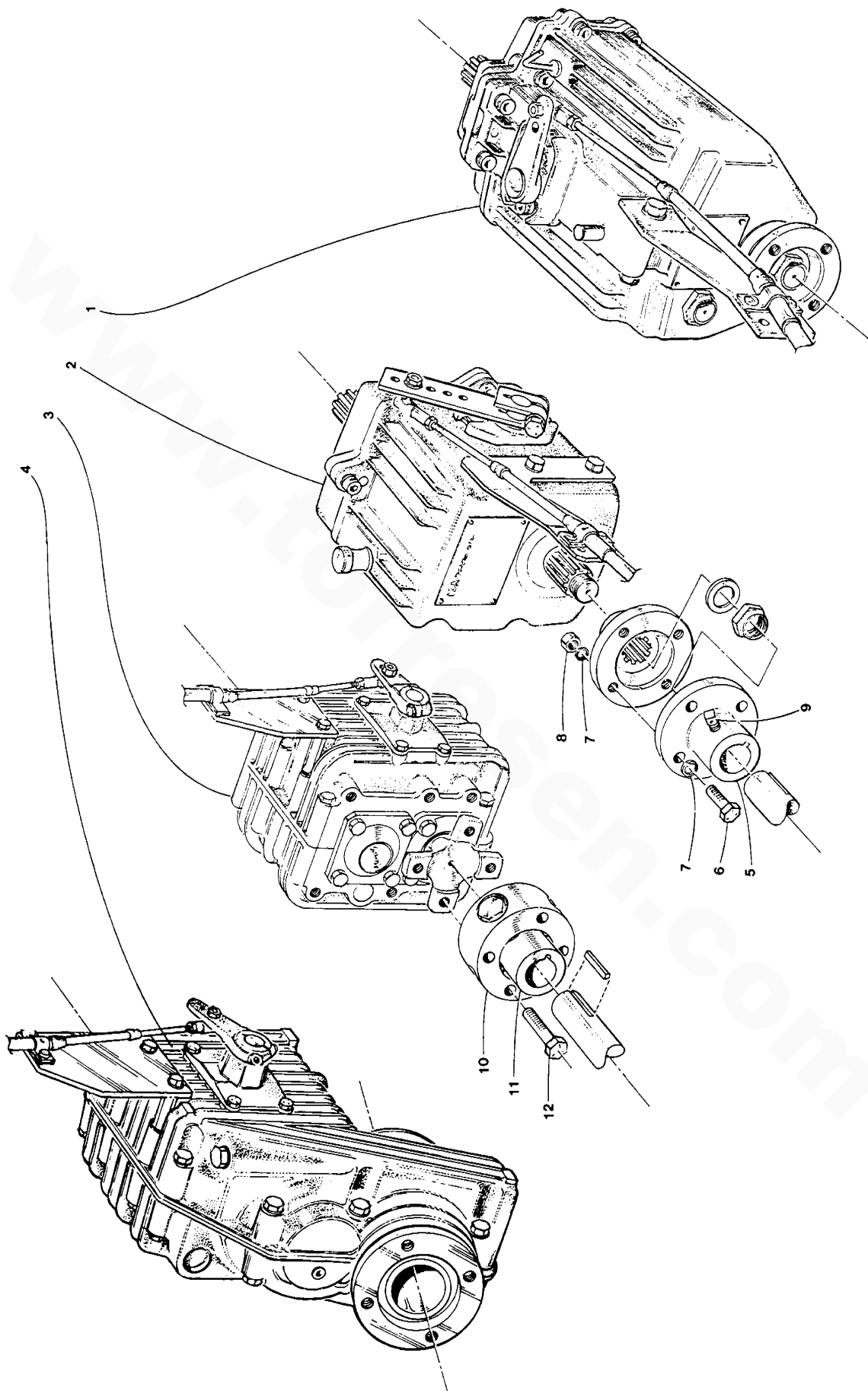

WESTERBEKE 52 - TRANSMISSION - COUPLING

REF	PN	NAME	REMARKS	QUAN
1	30951	BW GEAR	2.0 TO 1	1
3- 1	31248	HBW GEAR	MODEL 150 1.6 TO 1	1
3- 2	24631	HBW GEAR	MODEL 150 1.9 TO 1	1
3- 3	31252	HBW GEAR	MODEL 220 2.7 TO 1	1
4- 1	31249	HBW GEAR	V-DRIVE 1.8 TO 1	1
4- 2	30042	HBW GEAR	V-DRIVE 2.1 TO 1	1
5- 1	23679	COUPLING	BW-HBW-S1000-BORE 0.75	1
5- 2	23680	COUPLING	BW-HBW-S1000-BORE 0.875	1
5- 3	23681	COUPLING	BW-HBW-S1000-BORE 1.0	1
5- 4	23682	COUPLING	BW-HBW-S1000-BORE 1.125	1
5- 5	23683	COUPLING	BW-HBW-S1000-BORE 1.25	1
5- 6	23684	COUPLING	BW-HBW-S1000-BORE 1.375	1
5- 7	23685	COUPLING	BW-HBW-S1000-BORE 1.5	1
5- 8	23706	COUPLING	HBW V-DRIVE-BORE 0.75	1
5- 9	23707	COUPLING	HBW V-DRIVE-BORE 0.875	1
5-10	23708	COUPLING	HBW V-DRIVE-BORE 1.0	1
5-11	23709	COUPLING	HBW V-DRIVE-BORE 1.125	1
5-12	23710	COUPLING	HBW V-DRIVE-BORE 1.25	1
5-13	23711	COUPLING	HBW V-DRIVE-BORE 1.375	1
5-14	23712	COUPLING	HBW V-DRIVE-BORE 1.5	1
5-15	23686	COUPLING	WARNER HYDRAULIC 5IN FLANGE-BORE 1.0	1
5-16	23687	COUPLING	WARNER HYDRAULIC 5IN FLANGE-BORE 1.125	1
5-17	23688	COUPLING	WARNER HYDRAULIC 5IN FLANGE-BORE 1.25	1
5-18	23689	COUPLING	WARNER HYDRAULIC 5IN FLANGE-BORE 1.375	1
5-19	23690	COUPLING	WARNER HYDRAULIC 5IN FLANGE-BORE 1.5	1
6- 1	31606	CAPSCREW	3/8NC X 1-1/4	4
6- 2	18813	CAPSCREW	M10 X 20 DIN 933-HBW V-DRIVE	4
7- 1	31764	LOCKWASHER	3/8	8
7- 2	31790	LOCKWASHER	M10 DIN 137B-HBW V-DRIVE	4
8	31762	NUT	3/8NC	4
9- 1	23450	SETSCREW	COUPLING 7/16NC X 1	2
9- 2	23651	SETSCREW	COUPLING 3/8NC X 3/4	2
9- 3	23652	SETSCREW	COUPLING 3/8NC X 1	2
10- 1	11877	FLANGE	FLEXIBLE COUPLING-BW-HBW-WARNER 4IN	1
10- 2	12862	FLANGE	FLEXIBLE COUPLING-WARNER 5IN	1
11- 1	11878	HUB	FLEXIBLE COUPLING-BORE 0.875	1
11- 2	11879	HUB	FLEXIBLE COUPLING-BORE 1.0	1
11- 3	11880	HUB	FLEXIBLE COUPLING-BORE 1.125	1
11- 4	11881	HUB	FLEXIBLE COUPLING-BORE 1.25	1
11- 5	11882	HUB	FLEXIBLE COUPLING-BORE 1.375	1
11- 6	11883	HUB	FLEXIBLE COUPLING-BORE 1.5	1
11- 7	23364	HUB	FLEXIBLE COUPLING-BORE 1.0-5IN FLANGE	1
11- 8	19193	HUB	FLEXIBLE COUPLING-BORE 1.25-5IN FLANGE	1
11- 9	19194	HUB	FLEXIBLE COUPLING-BORE 1.375-5IN FLANGE	1
11-10	19195	HUB	FLEXIBLE COUPLING-BORE 1.5-5IN FLANGE	1
12	31612	CAPSCREW	3/8NC X 2-3/4	4
		NOTE	SEE NEXT PAGE FOR SHIFTING BRACKET	

WESTERBEKE SHIFT CONNECTION ON HBW

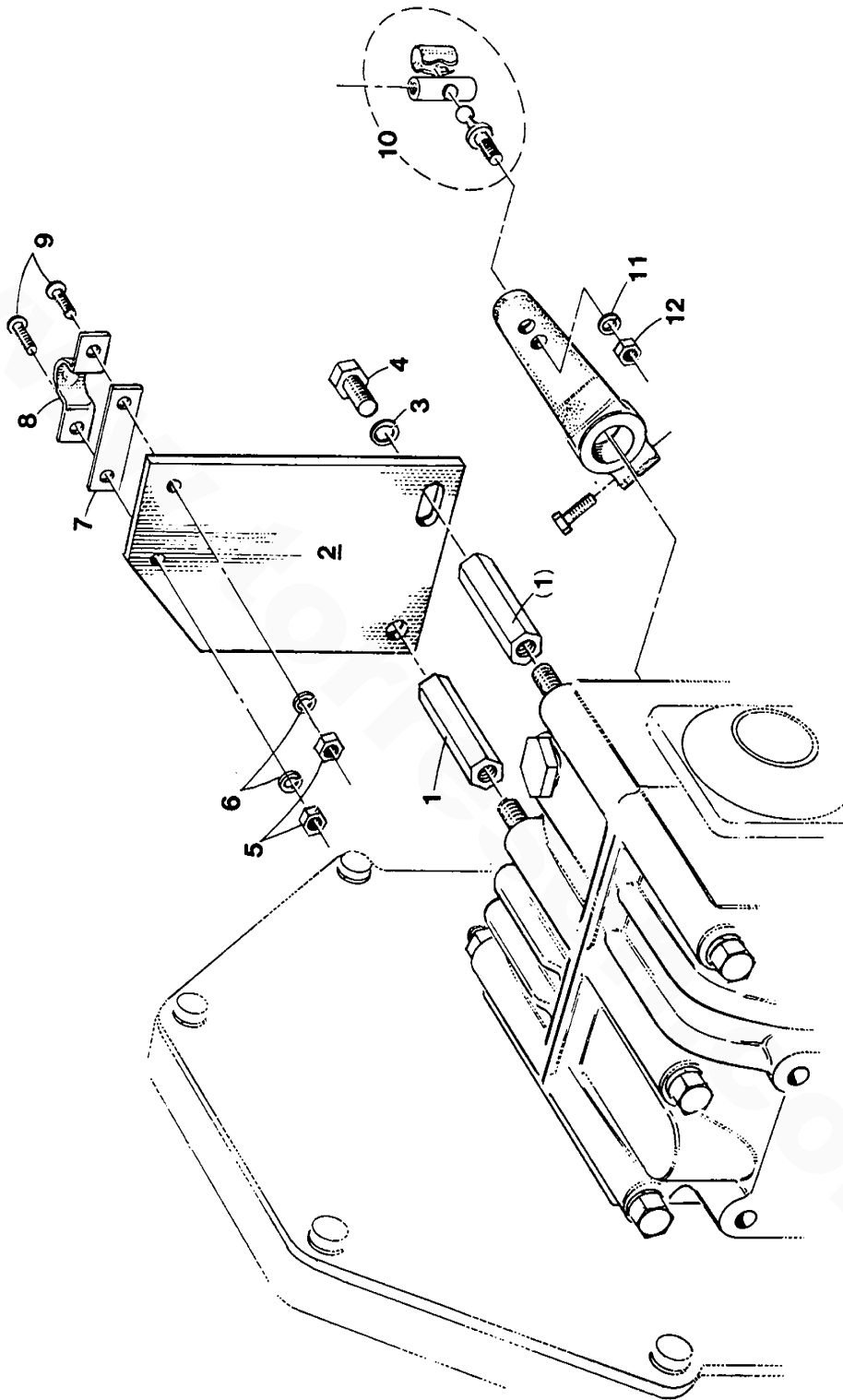

WESTERBEKE SHIFT CONNECTION ON HBW

REF	PN	NAME	REMARKS	QTY
1	30756	NUT	PILLAR-M8	2
2	30151	BRACKET	MOUNT SHIFTING CABLE TO HBW GEARS	1
3	31786	LOCKWASHER	M8 DIN 127	2
4	13630	CAPSCREW	M8 X 25 DIN 933	2
5		NUT	10-32	2
6		LOCKWASHER	10	2
7	13875	SHIM	CABLE CLAMP	1
8	13325	CLAMP	CABLE	1
9		SCREW	10-32 X 5/8	2
10	19364	BALL JOINT		1
11		LOCKWASHER	10	1
12		NUT	10-32	1

WESTERBEKE 15-20KW GENERATOR AND BACK END

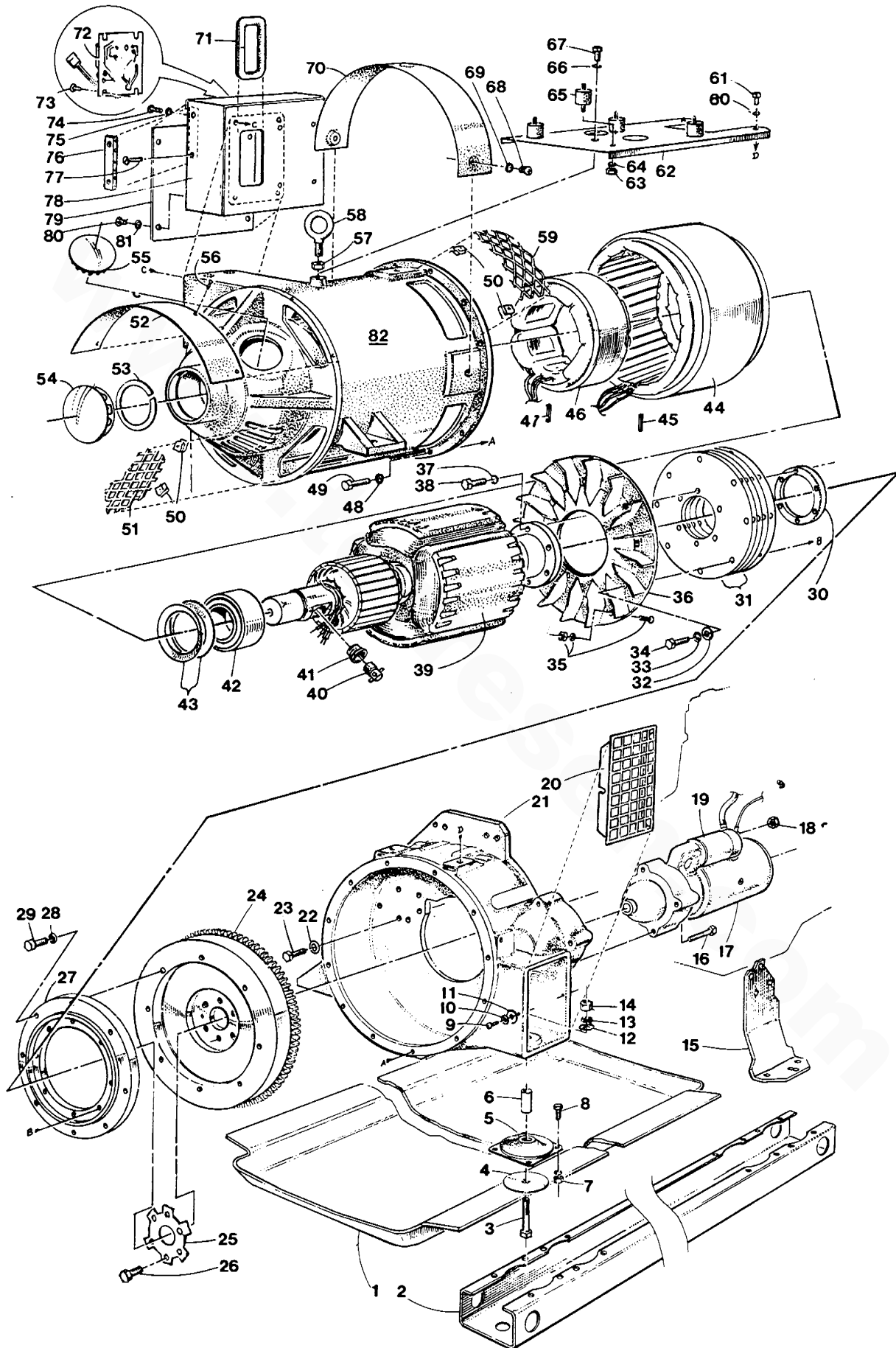

WESTERBEKE 15-20KW GENERATOR AND BACK END

REF	PN	NAME	REMARKS	QUAN
1	24675	DRIPTRAY		1
2	24701	RAIL		2
3- 1	31714	CAPSCREW	FRONT 1/2NC X 3-1/4	2
3- 2	31721	CAPSCREW	REAR 1/2NC X 5	2
4	24674	WASHER	SNUBBING	4
5- 1	21529	ISOLATOR	FRONT	2
5- 2	15239	ISOLATOR	REAR	2
6	16714	SPACER	ISOLATOR TO MOUNT	4
7	31756	NUT	5/16NC	16
8	31553	CAPSCREW	5/16NC X 3/4	16
9		SCREW	10-32 X 1/2	2
10		LOCKWASHER	10	2
11		WASHER	FLAT 10	2
12	31777	WASHER	FLAT 1/2	2
13	31776	LOCKWASHER	1/2	4
14	31774	NUT	1/2NC	4
15- 1	24703	MOUNT	FRONT-RIGHT 15KW	1
15- 2	30134	MOUNT	FRONT-LEFT 15KW	1
15- 3	24703	MOUNT	FRONT 20KW	2
16	31606	CAPSCREW	3/8NC X 1-1/4	3
17	23953	MOTOR	STARTER INCLUDING SOLENOID	1
18- 1	16891	NUT	3/8NC JAM BRASS	1
18- 2	16892	LOCKWASHER	BRASS 3/8	1
19	23338	SOLENOID	STARTER MOTOR	1
20	24783	GUARD	AIR DUCT	1
21	24257	HOUSING	FLYWHEEL	1
22	31764	LOCKWASHER	3/8	8
23	31630	CAPSCREW	3/8NF X 1	8
24	24728	FLYWHEEL	WITH RING GEAR	1
25	31166	TABWASHER		1
26	24411	BOLT	FLYWHEEL	6
27	32244	ADAPTER	FLYWHEEL TO GENERATOR DRIVE DISC	1
28	31764	LOCKWASHER	3/8	8
29	31608	CAPSCREW	3/8NC X 1-3/4	8
30	32245	RING	CLAMPING	1
31	32246	DISC	DRIVE	5
32	31759	WASHER	FLAT 5/16	8
33	31758	LOCKWASHER	5/16	8
34	31556	CAPSCREW	5/16NC X 1-1/4	8
35- 1		NOTE	SCREW-WASHERS-NUT ARE PART OF FACTORY	
35- 2			BALANCING-DO NOT REMOVE	
36	32247	FAN		1
37	31758	LOCKWASHER	5/16	6
38	31556	CAPSCREW	5/16NC X 1 1/4	6
39	32238	ROTOR		1
40	32242	RECTIFIER	BRIDGE	1
42	32243	BEARING		1
43	32233	WASHER	BELLEVILLE	2
44	32236	STATOR		1
45	32186	PIN	SPRING	1

WESTERBEKE 15-20KW GENERATOR AND BACK END

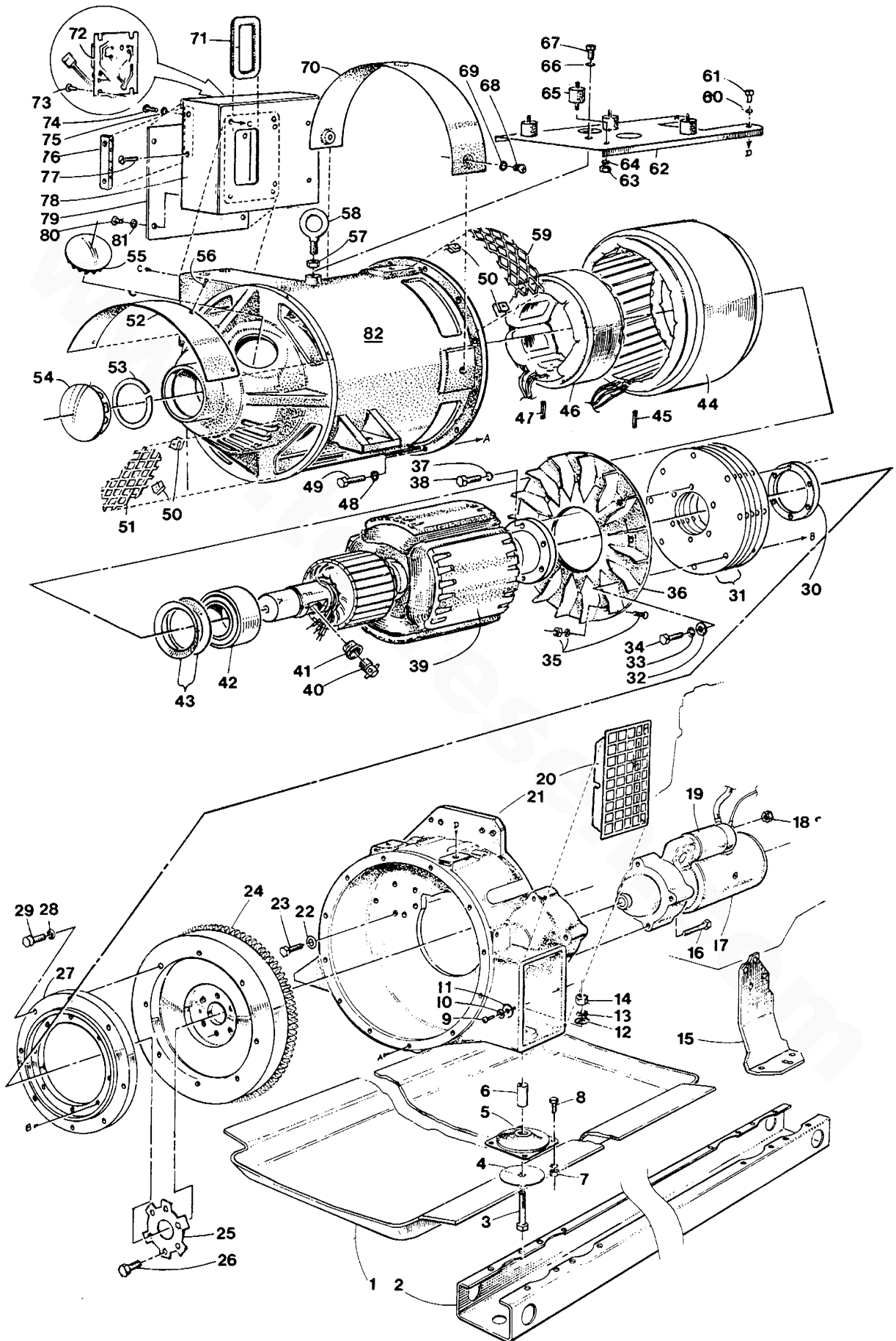

WESTERBEKE 15-20KW GENERATOR AND BACK END

REF	PN	NAME	REMARKS	QUAN
46	32237	STATOR	EXCITER	1
47	32186	PIN	SPRING	1
48	31764	LOCKWASHER	3/8	12
49	31607	CAPSCREW	3/8NC X 1-1/4	12
50	32185	CLIP	SCREEN RETAINING	16
51	32250	SCREEN	INLET AIR	4
52	32253	SHROUD	INLET AIR	1
53	32241	RING	RETAINING	1
54	32232	PLUG	BUTTON 3 DIA	1
55	32231	FLUG	BUTTON 2-1/4 DIA	1
56	32188	SCREW	DRIVE	4
57	31762	NUT	3/8NC	1
58	32234	EYEBOLT		1
59	32249	SCREEN	EXHAUST AIR	4
60	31758	LOCKWASHER	5/16	2
61	31553	CAPSCREW	5/16NX X 3/4	2
62	31167	BRACKET	PANEL MOUNT	1
63	31750	NUT	1/4NC	8
64	31752	LOCKWASHER	1/4	8
65	19024	ISOLATOR	PANEL MOUNT	4
66	31764	LOCKWASHER	3/8	1
67	31603	CAPSCREW	3/8NC X 3/4	1
68		SCREW	1/4NC X 1/2	3
69	31752	LOCKWASHER	1/4	3
70	32251	SHROUD	EXHAUST AIR	1
71	32252	GROMMET	BOX TO HOUSING	1
72 - 1	32240	REGULATOR	VOLTAGE 60HZ	1
72 - 2	32409	REGULATOR	VOLTAGE 50HZ	1
73	32187	STANDOFF	VOLTAGE REGULATOR MOUNT	4
74		SCREW	1/4NC X 1/2	4
75	31752	LOCKWASHER	1/4	4
76	32248	BLOCK	TERMINAL, NEUTRAL-GROUND	1
77		SCREW	1/4NF X 7/8	2
78	32239	BOX		1
79		COVER	INCL IN REF 52	
80		SCREW	10-32	4
81		LOCKWASHER	10	4
82 - 1	30875	GENERATOR		1
82 - 2	32235	HOUSING	STATOR	1
83	32290	STRAP	GROUND GENSET TO RAIL	1
84	32291	STRAP	GROUND PANEL TO GENSET	1

WESTERBEKE 52 - MISCELLANEOUS

REF	PN	NAME	REMARKS	QUAN
1- 1	32052	KIT A	SPARE PARTS	1
1- 2	32053	KIT B	SPARE PARTS-EXTENDED CRUISING	1
2- 1	32051	GASKET SET	UPPER	1
2- 2	32082	GASKET SET	COMPLETE	1
3	11592	PUMP	HAND-TO PUMP LUBE OIL FROM SUMP	1
4- 1	24993	FILTER	PRIMARY FUEL	1
4- 2	22266	SEPARATOR	WATER-FUEL	1
5	13174	MUFFLER	HYDRO HUSH WATER LIFT	1
6	15010	STRAINER	SEA WATER	1
7	24177	KIT	REMOTE FRESH WATER SURGE TANK	1
8- 1	17232	KIT	MORSE CABLE CONNECTING-PARAGON HYDRAULIC	1
8- 2	17252	KIT	MORSE CABLE CONNECTING-WARNER HYDRAULIC	1
9	13758	PAINT	RED-AEROSOL SPRAY CAN	1
10	12169	LINE	FLEXIBLE EXHAUST 1-1/2 X 12	1
11	21513	FILTER	REMOTE LUBE OIL	1
12	20654	SPLITTER	ALTERNATOR OUTPUT	1
13	30760	HARNESS	15 FOOT PANEL EXTENSION	1
14- 1	32009	SWITCH	GENERATOR SHIP-SHORE-15KW-3 WIRE	1
14- 2	32010	SWITCH	GENERATOR SHIP-SHORE-15KW-2 WIRE	1