

TECHNICAL MANUAL

**WESTERBEKE 70 • 100
Marine Diesel Engines**

**WESTERBEKE 25 • 32KW
Marine Diesel Generators**

**Publication no. 33355
Edition One
July 1983**



TECHNICAL MANUAL

**WESTERBEKE 70 • 100
Marine Diesel Engines**

**WESTERBEKE 25 • 32KW
Marine Diesel Generators**

**Publication no. 33355
Edition One
July 1983**



SECTION INDEX

GENERAL

Introduction	Operation
Installation	Maintenance

ENGINE OVERHAUL

OTHER OVERHAUL

- Marine Engine Electrical System
- Cooling System (External)
- Transmissions

GENERATOR SETS

HYDRAULIC CRANKING SYSTEM

SERVICE BULLETINS

IMPORTANT

PRODUCT SOFTWARE NOTICE

Product software of all kinds, such as brochures, drawings, technical data, operator's and workshop manuals, parts lists and parts price lists, and other information, instructions and specifications provided from sources other than Westerbeke, is not within Westerbeke's control and, accordingly, is provided to Westerbeke customers only as a courtesy and service. WESTERBEKE CANNOT BE RESPONSIBLE FOR THE CONTENT OF SUCH SOFTWARE, MAKES NO WARRANTIES OR REPRESENTATIONS WITH RESPECT THERETO, INCLUDING THE ACCURACY, TIMELINESS OR COMPLETENESS THEREOF, AND WILL IN NO EVENT BE LIABLE FOR ANY TYPE OF DAMAGES OR INJURY INCURRED IN CONNECTION WITH, OR ARISING OUT OF, THE FURNISHING OR USE OF SUCH SOFTWARE.

For example, components and sub-assemblies incorporated in Westerbeke's products and supplied by others (such as engine blocks, fuel systems and components, transmissions, electrical components, pumps and other products) are generally supported by their manufacturers with their own software, and Westerbeke must depend on such software for the design of Westerbeke's own product software. Such software may be outdated and no longer accurate. Routine changes made by Westerbeke's suppliers, of which Westerbeke rarely has notice in advance, are frequently not reflected in the supplier's software until after such changes take place.

Westerbeke customers should also keep in mind the time span between printings of Westerbeke product software, and the unavoidable existence of earlier, non-current Westerbeke software editions in the field. Additionally, most Westerbeke products include customer-requested special features that frequently do not include complete documentation.

In sum, product software provided with Westerbeke products, whether from Westerbeke or other suppliers, must not and cannot be relied upon exclusively as the definitive authority on the respective product. It not only makes good sense, but is imperative that appropriate representatives of Westerbeke or the supplier in question be consulted to determine the accuracy and currency of the product software being consulted by the customer.

INTRODUCTION

IMPORTANT

THIS MANUAL IS A DETAILED GUIDE TO THE INSTALLATION, START-UP, OPERATION AND MAINTENANCE OF YOUR WESTERBEKE MARINE DIESEL ENGINE. THE INFORMATION IT CONTAINS IS VITAL TO THE ENGINE'S DEPENDABLE, LONG TERM OPERATION.

READ IT !

KEEP IT IN A SAFE PLACE !

KEEP IT HANDY FOR REFERENCE AT ALL TIMES !

FAILURE TO DO SO WILL INVITE SERIOUS RISK, NOT ONLY TO YOUR INVESTMENT BUT YOUR SAFETY AS WELL.

UNDERSTANDING THE DIESEL....

The diesel engine closely resembles the gasoline engine inasmuch as the mechanism is essentially the same. Its cylinders are arranged above its closed crankcase; its crankshaft is of the same general type as that of a gasoline engine; it has the same sort of valves, camshaft, pistons, connecting rods, lubricating system and reverse and reduction gear.

Therefore, it follows to a great extent that a diesel engine requires the same preventative maintenance as that which any intelligent operator would give to a gasoline engine. The most important factors are proper maintenance of the fuel, lubricating and cooling systems. Replacement of fuel and lubricating filter elements at the time periods specified is a must, and frequent checking for contamination (i.e. water, sediment, etc.) in the fuel system is also essential. Another important factor is the use of the same brand of "high detergent" diesel lubricating oil designed specifically for diesel engines.

The diesel engine does differ from the gasoline engine, however, in the method of handling and firing its fuel. The carburetor and ignition systems are done away with and in their place is a single component - the Fuel Injection Pump - which performs the function of both.

Unremitting care and attention at the factory have resulted in a Westerbeke engine capable of many thousands of hours of dependable service. What the manufacturer cannot control, however, is the treatment it receives in service. This part rests with you!

ORDERING PARTS

Whenever replacement parts are needed, always include the complete part description and part number (see separate Parts List furnished, if not part of this publication). Be sure to include the engine's model and serial number. Also, be sure to insist upon Westerbeke factory packaged parts, because "will fit" parts are frequently not made to the same specifications as original equipment.

GENERATOR SETS

Westerbeke diesels are used for both the propulsion of boats and for generating electrical power. For generator set applications, all details of this Manual apply, except in regard to certain portions of the Installation, Operation and Maintenance sections. Additional information is provided in the section titled Generator Sets, Section T.

YOUR NOTES

www.torresen.com

INSTALLATION

FOREWORD

Since the boats in which these engines are used are many and varied, details of engine installation are equally so. It is not the purpose of this section to advise boatyards and engine installers on the generally well understood and well developed procedures for installation of engines. However, the following outline of general procedure is included because it is valuable in explaining the functions of each component, the reasons why, the precautions to be watched and the relationship of the installation to the operation of the engine. There are details of the installation which should have a periodic check and of which the operator should have a thorough understanding to insure good operating conditions for the engine and correct procedure for its servicing.

INSPECTION OF EQUIPMENT

The engine is shipped from the factory mounted securely and properly crated. Accessory equipment is shipped in a separate small box, usually packed with the engine crate.

Before accepting shipment from the transportation company, the crate should be opened and an inspection made for concealed damage. If either visible or concealed damage is noted, you should require the delivering agent to sign "Received in damaged condition". Also check contents of the shipment against the packing list and make sure note is made of any discrepancies. This is your protection against loss or damage. Claims for loss or damage must be made to the carrier, not to J. H. Westerbeke Corporation.

RIGGING AND LIFTING

The engine is fitted with lifting rings.

Rope or chain slings should be attached to the rings and the engine lifted by means of tackle attached to this sling. The lifting rings have been designed to carry the full weight of the engine; therefore, auxiliary slings are not required or desired.

CAUTION: Slings must not be so short as to place the engine lifting eyes in significant sheer stress. Strain on the engine lifting eyes must not be in excess of 10° from the vertical.

The general rule in moving engines is to see that all equipment used is amply strong and firmly fixed in place. Move the engine a little at a time and see that it is firmly supported. Eliminate possibility of accidents by avoiding haste. Do not lift from the propeller coupling, or pry against this with a crowbar, as you may distort the coupling.

In some cases it may be necessary to lift the engine in other than the regular horizontal position. It may be that the engine must be lowered endwise through a small hatchway which cannot be made larger. If the opening is extremely restricted, it is possible to reduce, to some extent, the outside clearances such as alternator, cooling piping, manifold, filters, mounting lugs, etc. This accessory equipment should be removed by a competent mechanic and special care should be taken to avoid damage to any exposed parts and to avoid dirt entering openings. The parts which have been removed should be returned to position as soon as the restriction has been passed.

In case it is necessary to hoist the engine either front end upwards or reverse gear end upwards, the attachment of slings must be done very carefully to avoid the possibility of damage to the parts on which the weight may bear. It is best if special rigging work be done by someone experienced and competent in the handling of heavy machinery.

ENGINE HOLD DOWN BOLTS

It is recommended that bronze or stainless steel hanger bolts of appropriate size be used through the engine flexible mounts. Lag screws are less preferred because their hold on the wood is weakened every time they are moved, whereas the lag bolt stays in position and the nut on top is used to tighten the engine down or is removed to permit the engine to be lifted. The bolt itself stays in position at all times, as a stud, and the bond between the bolt and the wood is not weakened by its removal.

FOUNDATION FOR ENGINE

A good engine bed contributes much toward the satisfactory operation of the engine. The engine bed must be of rigid construction and neither deflect nor twist when subjected to the engine weight or the position the boat may have to take under the effects of rough seas. The bed must keep the engine within one or two thousandths of an inch of this position at all times. It has to withstand the forward push of the propeller which is applied to the propeller shaft, to the thrust washer bearing in the engine and finally to the engine bolts and engine bed.

In fiberglass hulls, we recommend that engine stringers be of wood or preformed fiberglass and be thoroughly glassed to the hull. This should allow for the engine isolator hold down bolts to be firmly installed in the beds, thus reducing noise and transmitted vibration.

The temptation to install the engine on a pair of fiberglass "angle irons" should be resisted. Such construction will allow engine vibrations to pass through to the hull. Flexible mounts require a firm foundation against which to react if they are to do their job. When possible, follow bed design "A" and avoid bed design "B".

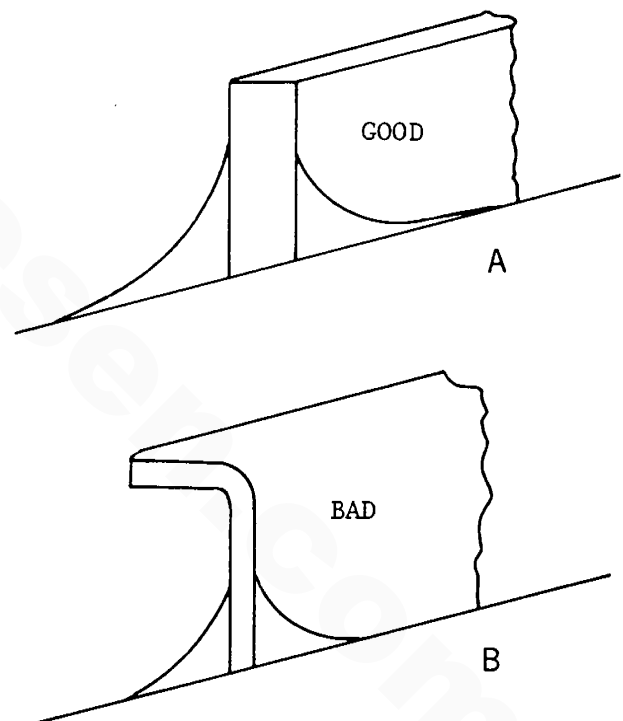

PROPELLER COUPLING

Each Westerbeke Diesel engine is regularly fitted with a suitable coupling connecting the propeller shaft to the engine.

The coupling must not only transmit the power of the engine to

turn the shaft, but must also transmit the thrust either ahead or astern from the shaft to the thrust bearing which is built into the reduction gear housing of the engine. This coupling is very carefully machined for accurate fit.

For all engine models, a propeller half-coupling, bored to shaft size for the specific order, is supplied. The coupling either has a keyway with set screws or is of the clamping type.

The forward end of the propeller shaft has a long straight keyway. Any burrs should be removed from the shaft end. The coupling should be a light drive fit on the shaft and the shaft should not have to be scraped down or filed in order to get a fit. It is important that the key be properly fitted both to the shaft and the coupling. The key should fit the side of the keyway very closely, but should not touch the top of the keyway in the hub of the coupling.

If it seems difficult to drive the coupling over the shaft, the coupling can be expanded by heating in a pail of boiling water. The face of the propeller coupling must be exactly perpendicular to the centerline or axis of the propeller shaft. The coupling set screw(s) heads are drilled and should be lock-wired once secured to prevent their loosening.

PROPELLER

The type and size of propeller varies with the gear ratio and must be selected to fit the application based upon boat tests. To utilize the full power of the engine, and to achieve ideal loading conditions, it is desirable to use a propeller which will permit the engine to reach its full rated RPM at full throttle under normal load.

ALIGNMENT OF ENGINE

The engine must be properly and exactly aligned with the propeller shaft. No matter what material is used to build a boat it will be found to be flexible to some extent and the boat hull will change its shape to a greater extent than is usually realized when it is launched and operated in the water. It is therefore very important to check the engine alignment at frequent intervals and to correct any errors when they may appear.

Misalignment between the engine and the propeller shaft is the cause of troubles which are often blamed on other causes. It will create excessive bearing wear, rapid shaft wear and will, in many cases, reduce the life of the hull by loosening the hull fastenings. A bent propeller shaft will have exactly the same effect and it is therefore necessary that the propeller shaft itself be perfectly straight.

One particularly annoying result of misalignment may be leakage of transmission oil through the rear oil seal. Check to make sure that alignment is within the limits prescribed.

The engine should be moved around on the bed and supported on the isolators until the two halves of the couplings can be brought together without using force and so that the flanges meet evenly all around. It is best not to drill the foundation for the foundation bolts until the approximate alignment has been accurately determined.

Never attempt a final alignment with the boat on land. The boat should be in the water and have had an opportunity to assume its final water form. It is best to do the alignment with the fuel and water tanks about half full and all the usual equipment on board and after

the main mast has been stepped and final rigging has been accomplished.

Take plenty of time in making this alignment and do not be satisfied with anything less than perfect results.

The alignment is correct when the shaft can be slipped backward and forward into the counterbore very easily and when a feeler gauge indicates that the flanges come exactly together at all points. The two halves of the propeller coupling should be parallel within 0.001 inches (A) per inch of coupling diameter.

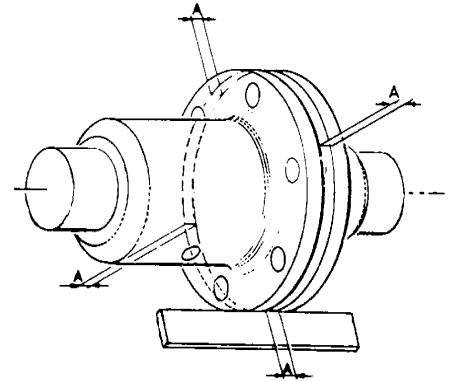

In making the final check for alignment, the engine half coupling should be held in one position and the alignment with the propeller coupling tested with the propeller coupling in each of four positions, rotated 90° between each position. This test will also check whether the propeller half coupling is in exact alignment on its shaft. Then, keeping the propeller coupling in one position, the alignment should be checked rotating the engine half coupling to full position each 90° from the next one.

The engine alignment should be rechecked after the boat has been in service for one to three weeks and, if necessary, the alignment remade. It will usually be found that the engine is no longer in alignment. This is not because the work was improperly done at first but because the boat has taken some time to take its final shape, and the engine bed and engine stringers when made of wood have probably absorbed some moisture. It may even be necessary to re-align at a further period.

The coupling should always be opened up and the bolts removed whenever the boat is hauled out or moved from the land to the water, and during storage in a cradle. The flexibility of the boat often puts a very severe strain on the shaft or the coupling or both when it is being moved. In some cases the shaft has actually been bent by these strains. This does not apply to small boats that are hauled out of the water when not in use, unless they are dry for a considerable time.

EXHAUST SYSTEM

Exhaust line installations vary considerably and each must be designed for the particular job. The general requirements are to provide an outlet line with a minimum of restrictions and arranged so that sea water, rain water or condensation cannot get back into the engine. There should be a considerable fall in the line between the exhaust manifold flange and the discharge end. This slope in the pipe makes it difficult for water to be driven in very far by a wave, and a steep drop followed by a long slope is better than a straight gradual slope. Avoid any depression or trough to the line which would fill with water and obstruct the flow of exhaust gas. Also avoid any sharp bends or the use of 90° fittings.

Brass or copper is not acceptable for wet exhaust systems, as the combination of salt water and diesel exhaust gas will cause rapid deterioration. Galvanized iron fittings and galvanized iron pipe are recommended for the exhaust line. The exhaust line must be at least

as large as the engine exhaust manifold flange and be increased in size if there is an especially long run. It should be increased by 1/2" in I.D. for every 10 feet beyond the first 10 feet.

Most exhaust systems today use a water lift type muffler such as the Westerbeke "Hydro-Hush". In most installations there is a dry, insulated high loop after the engine manifold and before the muffler to prevent water flowing backwards into the engine during cranking.

It is essential not to hang too much weight in the form of exhaust system components rigidly from the engine manifold. Generally, it is permissible to directly connect a pipe nipple and a water jacketed exhaust elbow, which two components weigh about 8 pounds (4 kg). If there are more components to be rigidly connected to each other than will weigh 8 pounds, then a flexible exhaust section must be installed between the manifold outlet and the exhaust system.

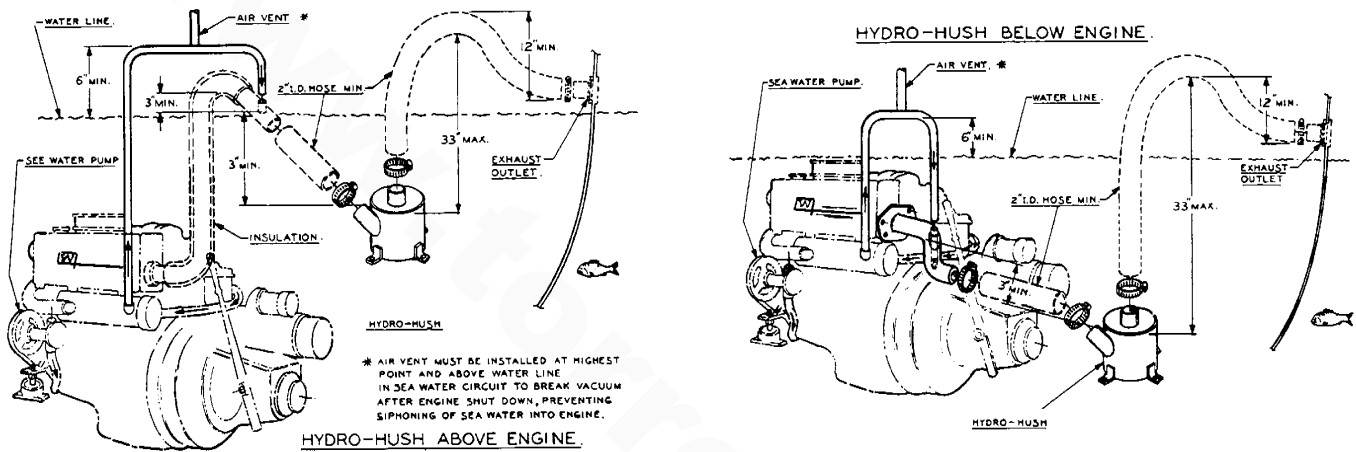

WATER LIFT EXHAUST SYSTEM WITH "HYDRO-HUSH MUFFLER"

The exhaust system must be supported or suspended independently of the engine manifold, usually using simple metal hangers secured to the overhead.

All dry portions of the exhaust system should be wrapped in suitable insulation material to keep surface temperatures as low as possible.

Many installations use flexible rubber exhaust hose for the water cooled section of the exhaust line because of the ease of installation and flexibility. Provide adequate support for the rubber hose to prevent sagging, bending and formation of water pockets.

Always arrange the rubber hose section so that water cannot possibly flow back into the engine. Also make sure that entering sea water cannot spray directly against the inside of the exhaust piping. Otherwise, excessive erosion will occur.

MEASURING EXHAUST GAS BACK PRESSURE

Back pressure must be measured on a straight section of the exhaust line and as near as possible to the engine exhaust manifold. The engine should be run at maximum load during the measurement period. Set-up should be as shown below.

1. For normally aspirated engines:

<u>Pressure Test</u>	<u>Mercury Test</u>	<u>Water Column</u>
1-1/2" Max PSI	3" Mercury	= 39"

Checking The Back Pressure

1. Exhaust pipe flange
 2. Exhaust line
 3. Transparent plastic hose, partly filled with water.
- Measurement "A" may not exceed 39" for normally aspirated engines.

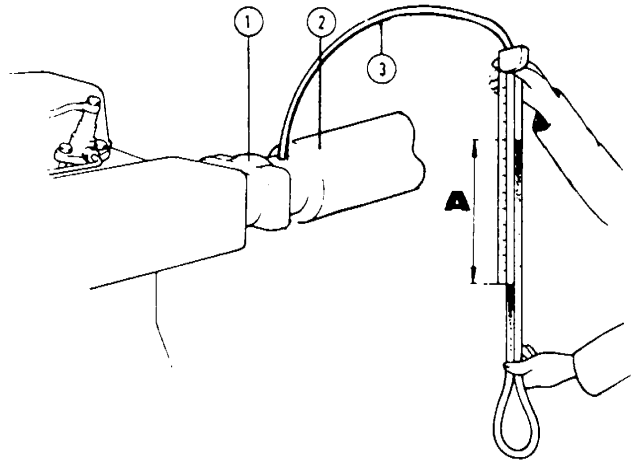

WATER CONNECTIONS

Seacocks and strainers should be of the full flow type at least one size greater than the inlet thread of the sea water pump. The strainer should be of the type which may be withdrawn for cleaning while the vessel is at sea.

Water lines can be copper tubing or wire-wound, reinforced rubber hose. In any case, use a section of flexible hose that will not collapse under suction, between the hull inlet and engine and between the outlet and the exhaust system. This takes up vibration and permits the engine to be moved slightly when it is being re-aligned. Do not use street elbows in suction piping. All pipe and fittings should be of bronze. Use sealing compound at all connections to prevent air leaks. The neoprene impeller in the sea (raw) water pump should never be run dry.

W100 SEA WATER CONNECTIONS

This engine requires a 21.5 GPM sea water flow at 3400 RPM for proper cooling.

In power boat applications with boat speeds over 10 knots, an intake scoop **MUST** be installed to force cooling water through the sea-cock at high speeds. The minimum seacock size is 1" and the minimum I.D. of hose connecting the sea cock and sea water pump is 7/8". The sea water pump **MUST** be connected directly to the intake (or strainer) without restrictive reducers or elbows.

Sea water flow from the heat exchanger **MUST** be divided by a 1/2" or larger tee at the inlet to the injected exhaust elbow so that only the necessary portion flows through the exhaust and so that the remaining portion has an unrestricted run back to the ocean. It is the installer's responsibility to balance these two flows so that adequate cooling water flows through the exhaust to cool it at full load and speed.

FUEL TANK AND FILTERS

Fuel tanks may be of fiberglass, monel, aluminum, plain steel or terne plate. If made of fiberglass, be certain that the interior is gel coated to prevent fibers from contaminating the fuel system. Copper or galvanized fuel tanks should not be used. Fuel tank(s) should be located as close to the engine as possible. The addition of an electric fuel pump to supply fuel to engines may be required when tanks are below engine level such as being an integral part of the vessel's keel or the tanks are distant from the engine.

Plumbing for the fuel supply and fuel return should not restrict fuel flow. 5/16" O.D. tubing is minimum and 3/8" O.D. tubing is

generally preferred. It is recommended that the fuel return be returned to the tank and that the return connection at the tank be extended down into the tank as if it were a fuel pick up. This is particularly important in those installations where tanks are below engine level to prevent air from entering the fuel system via the return system. Return fuel carries with it heat removed from the injection equipment on the engine during operation. It is important that this fuel be returned to the tank so that this heat carried by the fuel will be dispersed by the cool fuel in the tank.

A primary fuel filter/separator should be installed between the fuel tank and the engine. A secondary fuel filter is fitted on the engine and has a replaceable filter element.

To insure satisfactory operation, a diesel engine must have a dependable supply of clean diesel fuel. For this reason, cleanliness and care are especially important at the time when the fuel tank is installed, because dirt left anywhere in the fuel lines or tank will certainly cause fouling of the injector nozzles when the engine is started for the first time.

FUEL PIPING

Fuel supply and return lines should be fabricated of Coast Guard approved hose material or copper tubing using flared connections. The hose or tubing should be used in as long a length as possible to eliminate the use of unnecessary fittings and connections. A fuel shut off should be installed in the line between the fuel tank and primary fuel filter/separator and should be of the fuel oil type.

The fuel line plumbing from the tank to the engine compartment should be properly supported to prevent its chafing.

The final connection to the engine should be through flexible fuel hose to absorb engine movement and vibration.

ELECTRIC PANEL - PROPULSION

The Westerbeke all-electric panel utilizes an electronic tachometer with a built-in hourmeter. Mounted on the panel are a voltmeter, water temperature gauge, oil pressure gauge and keyswitch. Each instrument is lighted. The all-electric panel is isolated from ground and may be mounted where visible.

The generator panel in lieu of the tachometer has just an hourmeter along with the other gauges used in the propulsion panel and three switches to activate the start or stop circuits.

ELECTRICAL EQUIPMENT

All Westerbeke engines are supplied pre-wired and with plug-in connectors. Never make or break connections while the engine is running. Carefully follow all instructions on the wiring diagram supplied, especially those relating to the wiring of loads to generator.

Starter batteries should be located as close to the engine as possible to avoid voltage drop through long leads. It is bad practice to use the starter batteries for other services unless they require low amperage or are intermittent. In cases where there are substantial loads (from lights, refrigerators, radios, depth sounders, etc.), it is essential to have a complete, separate system and to provide charging current for this by means of a second alternator or "alternator output splitter".

Starter batteries must be of a type which permits a high rate of discharge (Diesel starting).

Carefully follow the recommended wire sizes shown in the wiring diagrams. Plan installation so the battery is close to the engine and use the following cable sizes:

- #1 - for distances up to 8 feet
- #1/0 - for distances up to 10 feet
- #2/0 - for distances up to 13 feet
- #3/0 - for distances up to 16 feet

CONTROLS

A keyswitch is used to start and stop propulsion engine models. Toggle switches are used to start and stop generator models.

The throttle and shift lever should be connected to a Morse type lever at the pilot's station by sheathed cables following cable manufacturer's routine recommendations regarding bonds to insure smooth cable operation.

The single-lever type control gives clutch and throttle control with full throttle range in the neutral position. The two-lever type provides clutch control with one lever and throttle control with the other, each independent of the other.

Control connections at engine and transmission must be securely mounted. After linkages are completed, check the installation for full travel, making sure that, when the transmission control lever at the pilot station is in forward, neutral and reverse, the shift lever on the transmission has sufficient travel to properly engage the transmission in the gear selected. Check the throttle control lever fuel injection pump for full travel from idle to the full throttle stop.

OPERATION

PREPARATION FOR FIRST START

The engine is shipped "dry"...with lubricating oil drained from the engine crankcase, lubricants from the transmission and coolant from the cooling system. Therefore, be sure to follow these recommended procedures carefully before attempting to start the engine for the first time.

1. Remove the oil fill cap and fill oil sump with a good grade of diesel lubricating oil having an API Spec code of CC or CD. Install the correct amount of oil as specified in the engine technical manual or Owner's/Operator's Manual.

NOTE: Installation angles will effect the oil level readings on the dipstick.

2. Fill the marine transmission and V-drive when applicable with the correct lubricant according to the gear model as specified in the engine technical manual or Owner's/Operator's Manual.

3. Fill the fresh water cooling system with a mixture of antifreeze and fresh water; a 50-50 mixture is recommended for year round use. The mixture should be concentrated enough to prevent freezing in your area of operation and during winter lay up.

The coolant level should be monitored once the engine is started to insure that all air is purged from the cooling system and coolant added as needed. Domestic water heaters plumbed off the heater should be checked for good coolant circulation to and from the engine and that all air has also been purged from the domestic water heater. Failure to do so can result in an unexpected overheating.

The surge tank on the engine should be maintained to within 1-1/2" of the filler neck. When the plastic recovery tank is used, the engine surge tank should be completely filled and the cap installed and the recovery tank filled half full.

4. Ensure battery water level is at least 3/8" above the battery plates and battery is fully charged so that it is capable of the extra effort that may be required on the first start.

5. Fill fuel tank with clean diesel fuel oil; No. 2 diesel fuel oil is recommended. The use of No. 1 is permissible but No. 2 is preferred because of its higher lubricant content.

FUEL SYSTEM

The fuel injection system of a compression ignition engine depends upon very high fuel pressure during the injection stroke to function correctly. Relatively tiny movements of the pumping plungers produce this pressure and, if any air is present inside the high pressure line, then this air acts as a cushion and prevents the correct pressure, and therefore fuel injection, from being properly achieved.

In consequence, it is essential that all air is bled from the system whenever any part of the system has been opened for repair or servicing.

BLEEDING PROCEDURES FOR W52, 15KW, W58, 20KW, W70, 25KW, W100 AND 32KW

Initial Engine Start-up (Engine stoppage due to lack of fuel)

1. Insure that the fuel tank(s) is filled with the proper grade of diesel fuel.
2. To attempt to fill any large primary filter/separator using the manual priming pump on the engine-mounted secondary fuel filter may prove futile and/or require a considerable amount of priming.
3. Insure that the fuel selector valve is "ON". Fuel systems with more than one tank make certain that the tank feeding the engine is the tank to which fuel is being returned.

The above procedures are basic for all initial engine start-ups or for restarting engines stopping due to lack of fuel.

WESTERBEKE W52, 15KW, W58, 20KW, W70, 25KW, W100 AND 32KW

1. Open the bleed screw on the top inboard side of the engine-mounted secondary fuel filter one to two turns using a 10mm box wrench (Bleed Point A). This fuel filter is equipped with a hand-operated priming pump. With the palm of your hand, pump this primer until fuel free of air flows from this point. Stop pumping and tighten the bleed screw.
2. With bleed screw A tightened, pump the hand primer several more times. This primes the injection pump. The injection pump incorporates a fuel supply pump which keeps the fuel system primed when the engine is running.
3. Loosen the four injector line attaching nuts at the base of each injector (Bleed Point B) one to two turns with a 16mm open end wrench. Place the throttle in the full open position and crank the engine over with the starter until fuel spurts by the nut and injector lines. Stop cranking and tighten each of the four nuts and proceed with normal starting procedure.

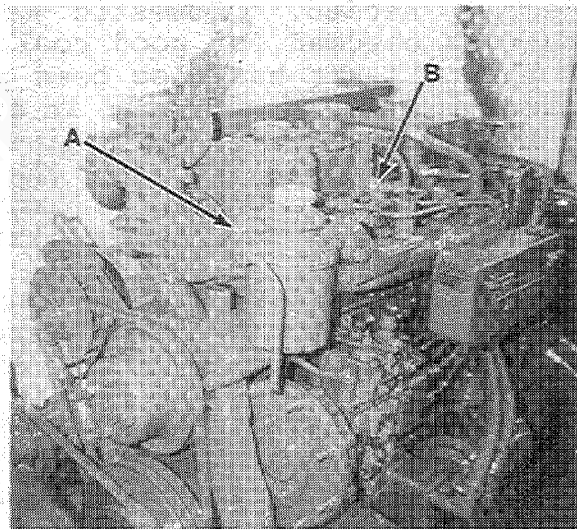

PREPARATION FOR STARTING

1. Check water level in expansion tank. It should be 1/2 to 1 inch below the top of the tank when cold.
2. Check the engine sump oil level.
3. Check the transmission fluid level and V-drive when applicable.
4. See that there is fuel in the tank and the fuel shut-off valve is open.
5. Check to see that the starting battery is fully charged, all electrical connections are properly made, all circuits in order and turn on the power at the battery disconnect switch.
6. Check the seacock and ensure that it is open.

STARTING THE ENGINE (COLD)

Most Westerbeke marine diesel engines are equipped with a cold starting aid to ease in the starting of your cold engine.

Propulsion Engines:

1. Check to see that the "STOP" lever (if installed) is in the "RUN" position.
2. Turn the keyswitch to the "ON" position. This will activate the instrument panel. (Note: Oil pressure and water temperature gauges will zero, the voltmeter will show battery voltage, the hourmeter will activate and the engine alarm will buzz.)
3. Push the key in to preheat the engine 15 - 20 seconds or more if ambient temperature requires. (Note: Do not use preheaters longer than 60 seconds prior to starting.)
4. Continuing to hold the key in for preheat, turn to the "START" position. This will energize the starter, cranking the engine over to start. Once the engine starts, release the key which will return to the on position and de-energize the preheat circuit. Retard the throttle to 800 - 1000 RPM and check oil pressure and raw water discharge. The alarm buzzer should shut off once oil pressure reaches 20 - 25 PSI.
5. If the engine fails to start in 20 - 30 seconds, release the key and turn it to the "OFF" position. Allow a few moments to pass and then repeat steps 2 through 4. Starter damage may occur from excessive cranking with the starter motor and filling of the exhaust system with raw water is possible.

Generator:

1. Depress the preheat switch on the panel for 15 - 20 seconds or more if ambient temperature requires. (Note: Do not use preheaters longer than 60 seconds prior to starting.)

2. Continuing to hold the preheat on, depress the start switch. When the engine starts, release the start switch but continue to hold the preheat switch on until gauge oil pressure reaches 20 - 25 PSI then release the preheat switch. (Note: Should the generator fail to start after 20 - 30 seconds of cranking, stop cranking and release the preheat. Allow a few moments to pass and repeat steps 1 and 2.

STARTING THE PROPULSION ENGINE (WARM)

If the engine is warm and has only been stopped for a short time, place the throttle in the partially open position and engage the starter as above, using preheat if necessary.

NOTE: Always be sure that the starter pinion has stopped revolving before again re-engaging the starter; otherwise, the flywheel ring gear or starter pinion may be damaged.

Extended use of the preheater beyond the time periods stated should be avoided to prevent damage to the glow plugs.

NEVER under any circumstances use or allow anyone to use ether to start your engine. If your engine will not start, have a qualified Westerbeke marine mechanic check your engine.

STARTING THE GENERATOR (WARM)

For starting a generator whose engine has only been shut down for a short period of time and is still warm:

1. Depress the preheat switch on the panel; hold for 5 - 10 seconds.
2. Continue to hold the preheat switch and depress the starter switch.

When the engine starts, release the starter switch but continue to hold the preheat switch until oil pressure reaches 20 - 25 PSI, then release it.

WHEN THE PROPULSION ENGINE AND GENERATOR START

1. Check for normal oil pressure immediately upon engine starting. Do not continue to run engine if oil pressure is not present within 15 seconds of starting the engine. On a generator unit, immediately release preheat switch and depress stop switch if necessary.
2. Check Sea Water Flow. Look for water at exhaust outlet. Do this without delay.
3. Recheck Crankcase Oil. After the engine has run 3 or 4 minutes, subsequent to an oil change or new installation, stop the engine and check the crankcase oil level. This is important as it may be

necessary to add oil to compensate for the oil that is required to fill the engine's internal oil passages and oil filter. Add oil as necessary. Check oil level each day of operation.

4. Recheck Transmission Fluid level. (This applies only subsequent to a fluid change or new installation.) In such a case, stop the engine after running for several minutes at 800 RPM with one shift into forward and one into reverse, then add fluid as necessary. Check fluid level each day of operation.
5. Recheck Expansion Tank Water Level, if engine is fresh water cooled. (This applies after cooling system has been drained or filled for the first time.) Stop engine after it has reached operating temperature of 170° - 190°F and add water to within one half to one inch of top of tank.

WARNING: The system is pressurized when overheated, and the pressure must be released gradually if the filler cap is to be removed. It is advisable to protect the hands against escaping steam and turn the cap slowly counter-clockwise until the resistance of the safety stops is felt. Leave the cap in this position until all pressure is released. Press the cap downward against the spring to clear the safety stops and continue turning until it can be lifted off.

6. Warm-up Instructions. As soon as possible, get the boat underway, but at reduced speed, until water temperature gauge indicates 130-150°F. If necessary, engine can be warmed up with the transmission in neutral at 1000 RPM.
7. Reverse Operation. Always reduce engine to idle speed when shifting gears. However, when the transmission is engaged, it will carry full engine load.

STOPPING THE PROPULSION ENGINE

1. Position shift lever in neutral.
2. Idle the engine for 2 to 4 minutes to avoid boiling and to dissipate some of the heat.
3. Turn off the keyswitch. The injection pumps are equipped with an electrical shut-off solenoid. When the key is turned off, the engine will stop immediately. (Note: Water temperature and oil pressure gauges will continue to show a reading.)

STOPPING THE GENERATOR

1. Remove the load from the generator.
2. Allow the generator to operate a few minutes with no load to dissipate some of the heat.
3. Depress the stop switch until the engine stops completely.

OPERATING PRECAUTIONS

1. Never run the engine for extended periods when excessive overheating occurs, as extensive internal damage can be caused. Engines operated in this manner will void the warranty.
2. DO NOT put cold water in an overheated engine. It can crack the cylinder head, block or manifold.
3. Keep intake silencer unobstructed.
4. Do not run engine at high RPM without clutch engaged.
5. Never Race a Cold Engine as internal damage can occur due to inadequate oil circulation.
6. Keep the engine and accessories clean.
7. Keep the fuel clean. Handle it with extreme care because water and dirt in fuel cause more trouble, and service life of the injection system is reduced. Maintain a good filter/separator between the engine and fuel tanks. Monitor it for water.
8. Do not allow fuel to run low, because fuel intake may be uncovered long enough to allow air to enter the injection system, resulting in engine stoppage requiring system bleeding.
9. Do not operate the engine with low or no oil pressure. Internal damage will result. This will void your engine warranty.
10. Do not be alarmed if temperature gauges show a high reading following a sudden stop after engine has been operating at full load. This is caused by the release of residual heat from the heavy metal masses near the combustion chamber. Prevention for this is to run engine at idle for a short period before stopping it. High temperature reading after a stop does not necessarily signal alarm against restarting. If there is no functional difficulty, temperatures will quickly return to normal when engine is operating.

ENGINE OPERATING RPM

1. Idle range: 700 - 900 RPM
This will vary with installations due to harmonics and vibrations.
2. Cruising range: 2000 - 2500 RPM
Hull shape, keel and hull displacement affect the horsepower needed to move the hull efficiently through the water at or near hull speed in a tolerable RPM range for lengthy cruising.
3. Maximum RPM (under load): 3000 RPM
The propeller should be selected that will allow the engine to achieve its maximum rated RPM + 100 RPM. Transmission reduction ratios will affect greatly the size propeller an engine can turn.

TEN MUST RULES

IMPORTANT

IMPORTANT

IMPORTANT

...for your safety and your engine's dependability.

ALWAYS -

1. Keep this Manual handy and read it whenever in doubt.
2. Use only filtered fuel oil and check lube oil level daily.
3. Check cooling water temperature frequently to make sure it is between 170° and 190°F.
4. Check engine coolant at least once daily.
5. Check transmission lubricant levels at least once daily.

NEVER -

6. Race a cold engine in neutral.
7. Run the engine unless the gauge shows proper oil pressure.
8. Break the injection pump seals.
9. Use cotton waste or fluffy cloth for cleaning or store diesel fuel in a galvanized container.
10. Subject the engine to prolonged overloading or continue to run it if excessive black smoke comes from the exhaust.

MAINTENANCE

PERIODIC ATTENTION:

After you have taken delivery of your engine, it is important that you make the following checks right after the first fifty hours of its operation.

Note: Check engine belt tensions periodically after initial engine start up. New belts will stretch.

FIFTY HOUR CHECKOUT (INITIAL)

Do the following:

1. Retorque the cylinder head bolts.
2. Retorque the rocker bracket nuts and adjust valve rocker clearance.
3. Change engine fuel filter.
4. Change engine lubricating oil and oil filter. Use a good grade of diesel oil, API Spec CC or better.
5. Check for fuel and lubricating oil leaks. Correct if necessary.
6. Check cooling system for leaks and inspect water level.
7. Check for loose fittings, clamps, connections, nuts, bolts, vee belt tensions, etc. Pay particular attention to loose engine mounts and engine mount fittings. Check engine alignment and make sure the propeller shaft is secure in the propeller shaft coupling.
8. Check the zinc anode (PN 11885) and replace as needed. If flaking, scrape down to solid zinc.
9. Check hose and electrical routing to and from the engine for security and that these hoses or wiring are not chafing on fiberglass or when passing through bulkheads.

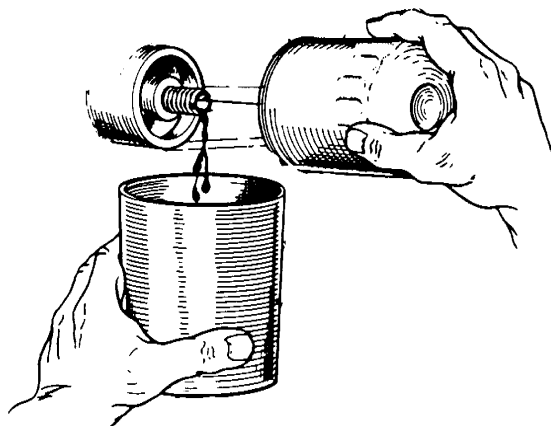

DAILY CHECKS

Do the following:

1. Check engine oil level with the dipstick. Maintain oil level between the low and the high mark on the dipstick.
2. Check engine coolant level. Add as necessary. Maintain coolant level between 1/2 and 1 inch of filler neck.

Note: With plastic coolant recovery tank, keep level between ADD and MAXI.)

3. Check transmission lubricant level and V-drive if applicable. Add lubricant as needed.

Note: Checking these fluid levels once each day prior to initial engine usage will help to spot losses before an unexpected problem arises.

SEASONAL CHECKS

Do the following:

1. Change engine lube oil and lube oil filter at least once a season or every 100 hours of engine operation.
2. Check belt tensions. Belts should be sufficiently tight when the alternator pulley can be grasped with the hand and cannot be slipped on the belt.
3. Check sea water pumps to insure no leakage is evident at the weep holes. Correct if leakage is noted. (Sea water pump should be visually checked as often as possible.)
4. Check fluid level in the battery(s) and insure connections are secure and clean.
5. Check the zinc anode in the main engine heat exchanger. Clean and replace as needed.
6. Check for loose fittings, clamps, electrical connections, nuts and bolts and coolant circulating hoses for good condition.
7. Change fuel oil filters once a season or every 200 hours.
8. Engine alignment should be checked at the beginning of each season, especially on those boats which are kept in dry storage during winter months and then returned to the water.

Note: This alignment check should be done with the boat in the water with mast stepped and rigging tuned.

9. Check condition and strength of antifreeze mixture in the engine coolant. Note color of coolant and, if scale or discoloration of coolant is noted, drain coolant from block and replace.
10. Wash primary filter bowl and screen. If filter bowl contains water or sediment, filter bowl and secondary oil fuel filter need be cleaned more frequently.
11. Check air intake silencer and insure that the inlet is unobstructed.
12. Change the transmission lubricant once a season or any time that it becomes discolored or rancid smelling. (Commercial or work vessels require more frequent changes.)

Refer to the transmission section of this manual for details on the correct lubricant for the different model gears.

END OF SEASON SERVICE (WINTERIZATION)

1. Check engine coolant for proper freeze protection. Drain and add antifreeze as needed. Run engine to insure complete circulation of antifreeze and recheck.
2. Check zinc anode (PN 11885) in heat exchanger and replace as needed. (Keep spares.)
3. Change and clean primary fuel filter/separators.
4. Replace secondary fuel filter mounted on engine.
5. Change engine lube oil and filter.
6. Flush raw water system with fresh water then run an antifreeze mixture through the raw water system to protect it against freezing.

Note: Feed the raw water system out of a bucket to flush the raw water system and to circulate antifreeze.

7. Remove the raw water pump impeller and examine it for cracks and insure that it is in serviceable condition for next season. Leave the impeller out of the pump until the engine is recommissioned. (Keep one or two spares.)
8. Close off the air intake to the engine with a well-oiled cloth.

- Note: In some instances the intake silencer will have to be removed to accomplish this. Be sure to remove at recommissioning.
9. Check belts on engine for good condition. Order replacements and/or spares as needed.
 10. Fill fuel tanks. Add additives to combat algae growth and fuel conditioners.

Note: Fuel additives with an alcohol base should not be used with fuel systems having Racor fuel filters/separators.

11. Shut off the fuel supply.
12. Change transmission lubricant.
13. Boats being hauled for dry storage should have the propeller shaft coupling disconnected from the transmission.
14. Check batteries for a full state of charge. Batteries with a low state of charge are susceptible to freezing. Turn off battery power to engine.
15. Close off exhaust openings on the outside of the hull.
16. Lubricate all linkage to throttle and shifting.
17. Remove starter and lubricate bendix drive and replace starter.

ENGINE OVERHAUL

The following sections contain detailed information relating to the proper operation characteristics of the major components and systems of the engine. Included are disassembly, rework and reassembly instructions for the guidance of suitable equipped and staffed marine engine service and rebuilding facilities. The necessary procedures should be undertaken only by such facilities.

Additional operating characteristics are included in the Operation Section of this manual.

Any replacements should be made only with genuine Westerbeke parts.

Engine Disassembly.....	25
Engine Inspection and Repair.....	34
Engine Assembly.....	53
Compression Pressure.....	68
Engine Lubricating System.....	69
Fresh Water Pump.....	75
Fuel System.....	78
Injection Pump.....	79
Fuel Injectors.....	81
Fuel System Troubleshooting.....	85
Technical Data.....	88

YOUR NOTES

www.torresen.com

ENGINE DISASSEMBLY

PREPARATION FOR DISASSEMBLY

- A. Clean the exterior of the engine of any deposits of dirt and oil.
- B. Be careful not to damage each disassembled component part.
- C. Arrange parts in the order of disassembly. Mark or label parts as needed to insure proper mating and reassembly. Keep parts clean.
- D. Drain all fluids and oil from engine block and transmission prior to engine disassembly.
- E. Place the engine on a suitable stand or bench for disassembly.
- F. Remove the engine electrical harness in its entirety. Tag terminal ends to help insure proper refitting.
- G. Metric threads are used for the W70 engine while inch threads (unified threads) are used for the W100 engine.

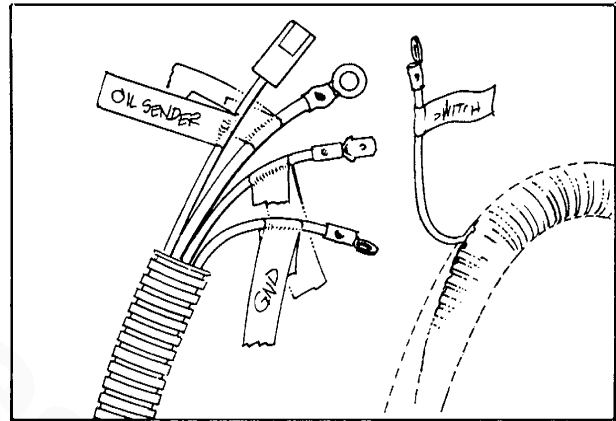
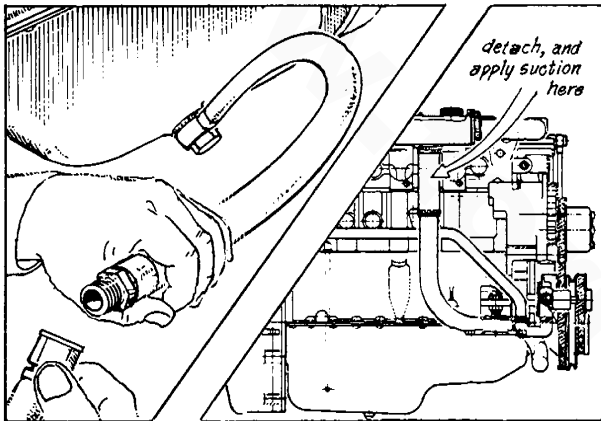

REMOVING ENGINE EQUIPMENT AND PARTS

Remove parts in the following order:

1. Remove the engine starting motor.
2. Remove the transmission and related hardware.

3. Remove the transmission damper plate from the engine flywheel.

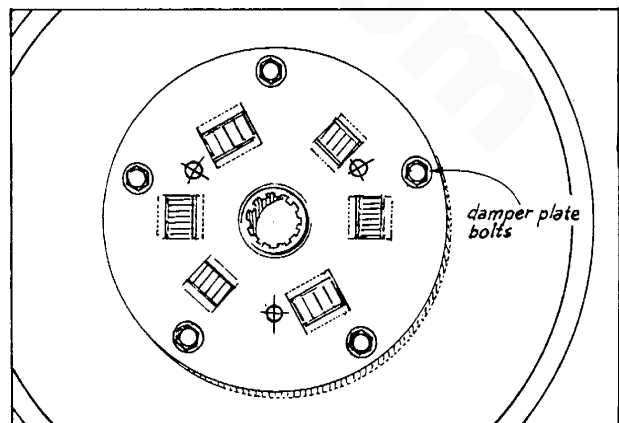

4. Remove the engine oil cooler and oil hoses. Note oil hose connections on oil filter engine mounting bracket.
5. Remove engine heat exchanger.
6. Remove the engine bellhousing and circuit breaker-preheat solenoid mounting plate.

7. Remove the engine flywheel.

NOTE: Loosen the front crankshaft pulley nut before removing the flywheel.

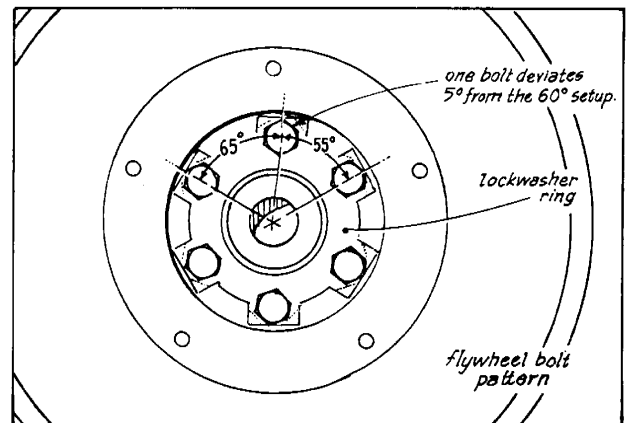

8. Remove engine backplate.
9. Remove the engine alternator, drive belt, support bracket and adjusting strap.
10. Remove the engine mounted sea water pump, drive belt and support bracket from the front cover.

11. Remove the thermostat cover, hose and thermostat. Leave temperature switch in place.

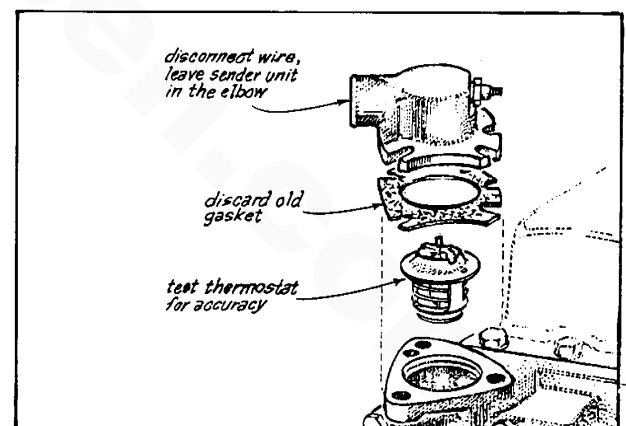

12. Remove the fresh water circulating pump with connecting hoses and formed tube to the exhaust manifold/expansion tank.

13. Remove the exhaust manifold - expansion tank in its entirety.

Remove the return pipe on the W100.

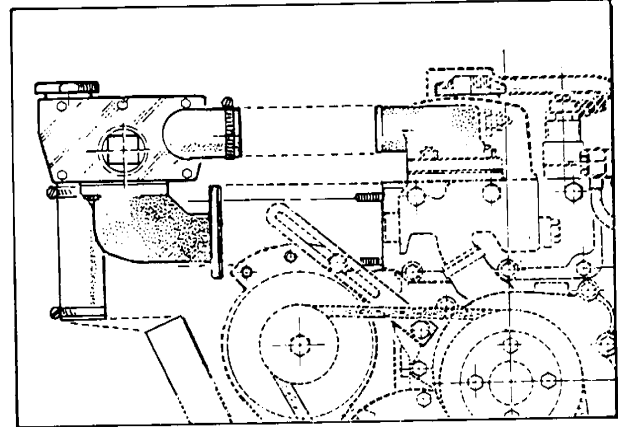

14. Remove the air intake silencer.
15. Remove the high pressure injection lines.
16. Remove the engine dipstick tube from the block and sump.
17. Remove the air intake manifold and breather hose.
18. Remove the engine oil filter and mounting bracket from the engine block.
19. Remove the engine mounted fuel filter with related lines. Note the positions of sealing washers that attach fuel lines to the fuel filter and the injection pump.
20. Remove the fuel injection pump:

NOTE: Scribe mating marks on pump body flange and the timing gear case before removal.

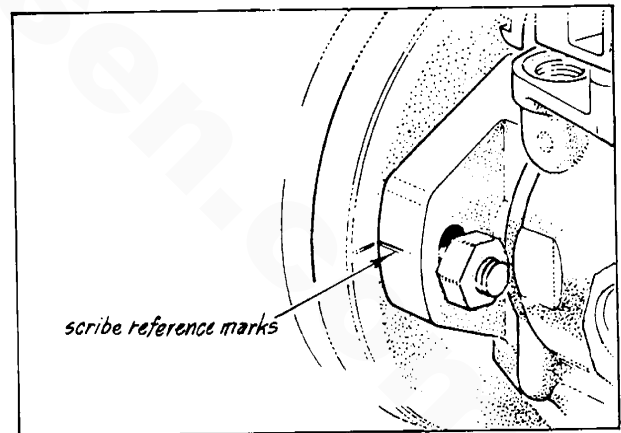

(a) Loosen the two injection pump hold down nuts. Do not remove entirely. The hold down nut on the engine side of the pump can be gotten at by using a 1/4" universal socket and extension with ratchet.

(b) Place the keyway on the injection pump shaft in the 12:00 position with the aid of the front crankshaft pulley bolt before attempting to remove the injection pump.

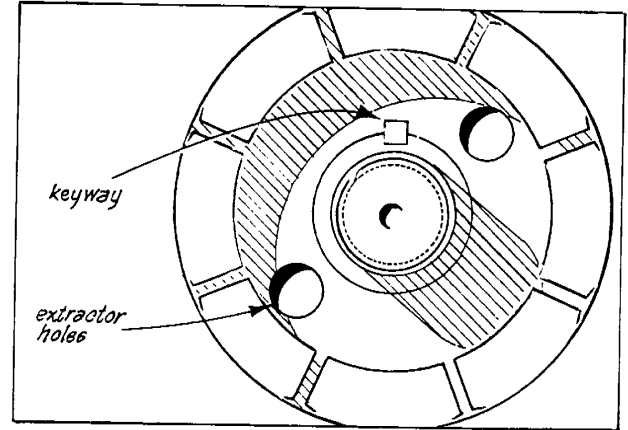
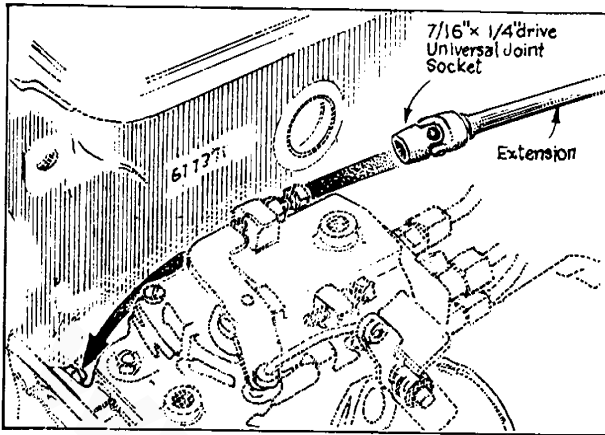

(c) With a suitable nylon drift and hammer, gently tap the injection pump shaft to dislodge it from the keyed drive gear. The loose hold down nuts will prevent the pump from falling from the engine.

(d) Once loosened, remove the hold down nuts and washers and carefully withdraw the pump from the drive gear and engine so as to avoid losing the injection pump drive key inside the timing case.

21. Removal of the fuel injectors:

(a) Remove the fuel return line from the top of the injectors by removing the four attaching bolts.

NOTE: There are sealing washers under these bolts which should be replaced upon reassembling.

(b) With a suitable 27 mm deep socket, unscrew the injectors from the cylinder head on the W70. On the W100, remove the nuts from the retaining flange and lift injectors out.

(c) Remove the injector sealing washer from the head once the injectors are removed.

NOTE: These should be replaced upon reassembly.

DISASSEMBLING ENGINE

Disassemble in the following order:

1. Cylinder head rocker cover

2. Cylinder head bolts

NOTE: Loosen the cylinder head bolts equally and gradually in the order shown in the figure.

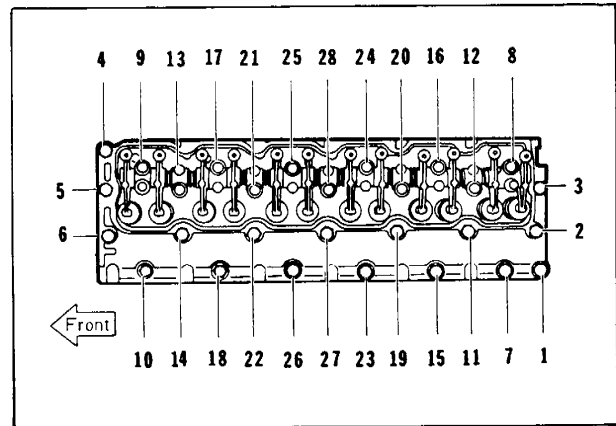
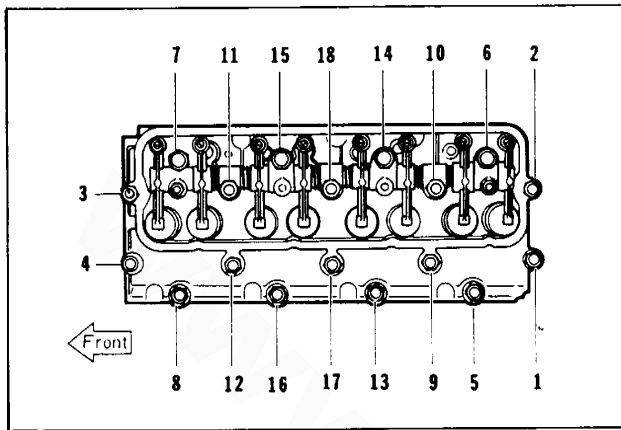

3. Rocker arm assembly

4. Valve stem caps. Label each cap as to which valve it belongs so as not to lose them when removing the cylinder head.
5. Push rods. Label each rod as to which valve it belongs.
6. Cylinder head
7. Cylinder head gasket

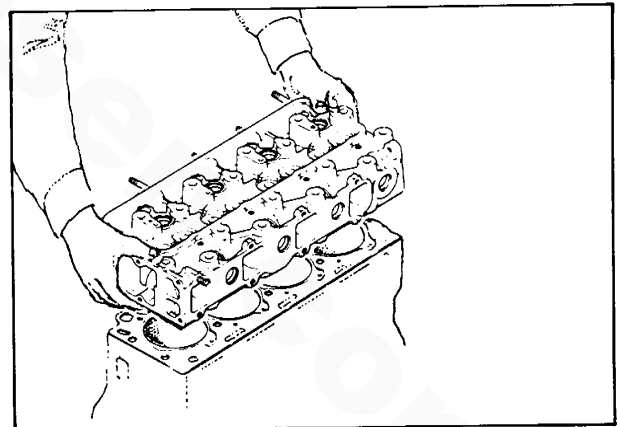
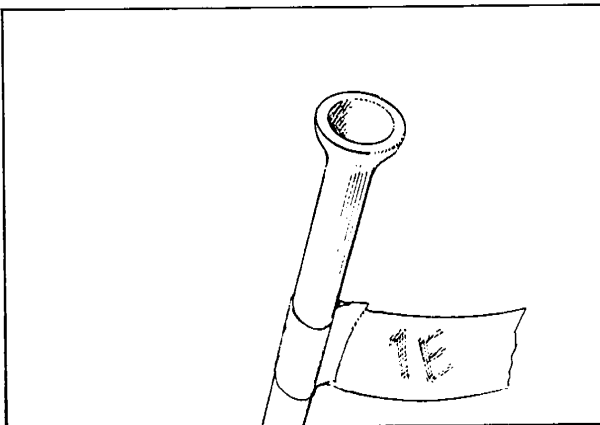

8. Disassembling rocker arm assembly

- (a) Stop ring
- (b) Wave washer
- (c) Rocker arm
- (d) Rocker bracket
- (e) Rocker arm
- (f) Spring

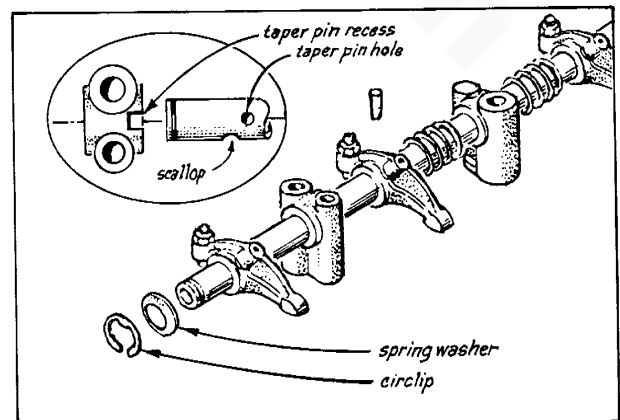

9. Intake and exhaust valves
With the aid of a suitable valve spring compressor tool, remove the valves from the cylinder head.

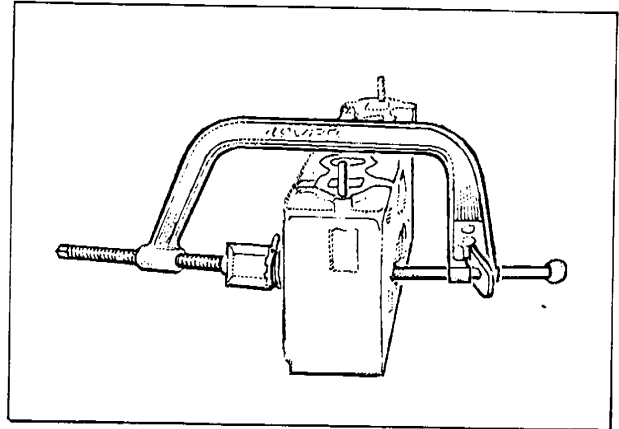

NOTE: After removing the valve assemblies, arrange or label them in the order of removal so that they can be reinstalled in their original positions.

10. Crankshaft pulley using the taper ring remover
11. Timing gear cover

12. Injection pump drive gear

- (a) Friction gear
(b) Drive gear

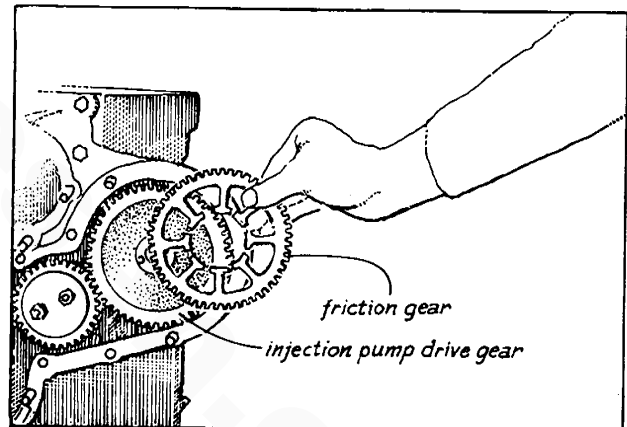

13. Camshaft gear

- (a) Wedge a clean cloth between the camshaft gear and idler gear; remove the retaining bolt.
(b) Retaining plate
(c) Friction gear
(d) Using a suitable bearing puller, remove the camshaft gear.

14. Idler gear

- (a) Attaching nuts
(b) Thrust plate
(c) Idler gear
(d) Idler gear hub

15. Crankshaft gear

- (a) Wave washer
- (b) Friction gear
- (c) Using a suitable puller, remove the crankshaft gear and key.

16. Oil pan and oil pan upper block

17. Oil pump assembly

NOTE: Remove the oil pump assembly after loosening the oil pump set screw located on the side of the block.

18. Oil jets on the W70

19. Timing gear case

20. Camshaft

NOTE: Turn the engine upside down for removing the camshaft. This will allow the valve lifters to seat on the block bosses away from the cam lobes.

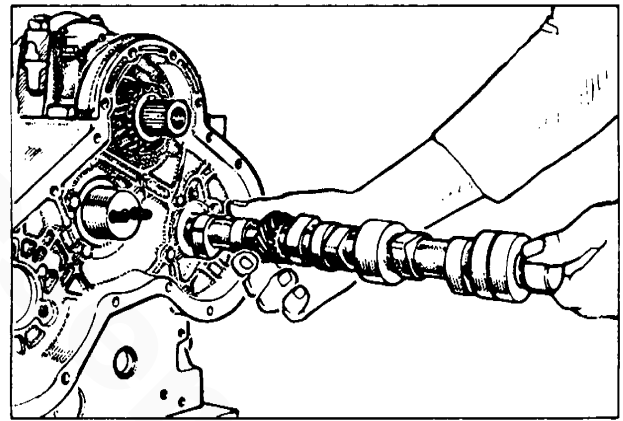
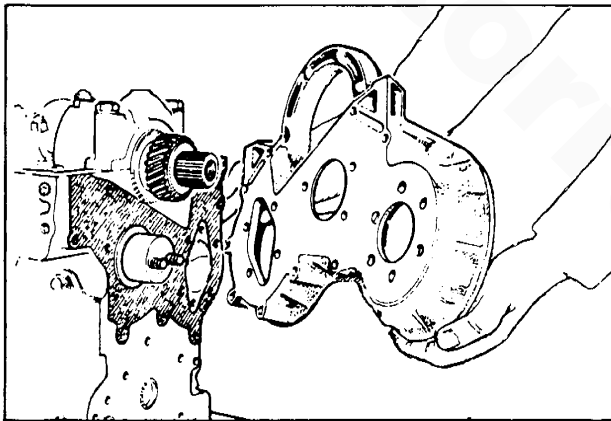

21. Rear oil seal assembly

22. Connecting rod bearing caps

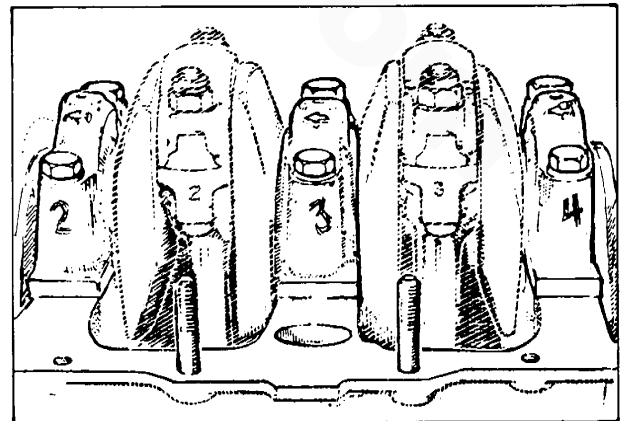

23. Piston and connecting rod assemblies

NOTE: After removing the piston and connecting rod assemblies, install the connecting rod cap on the connecting rod temporarily. Do not mix rods and caps.

24. Piston rings using a suitable ring expander

NOTE: After removing the piston rings, note the order that they are removed and which side of the ring faces the piston crown.

25. Piston pin

- (a) Remove the wrist pin snap rings.
- (b) Using a nylon drift, drive the wrist pin from the piston and rod.

NOTE: If the piston pin is tightly fitted, heat the piston head with the aid of a hot plate or similar device.

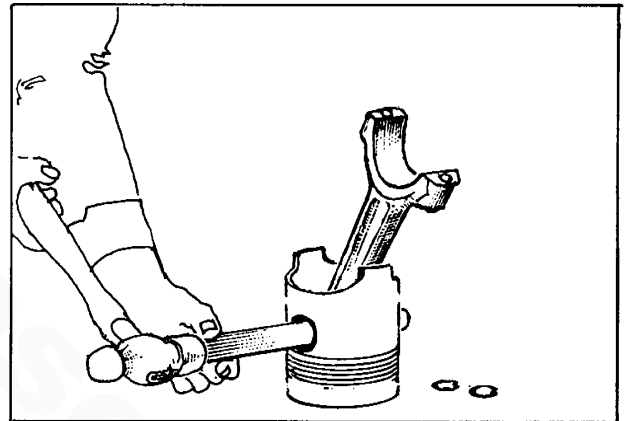
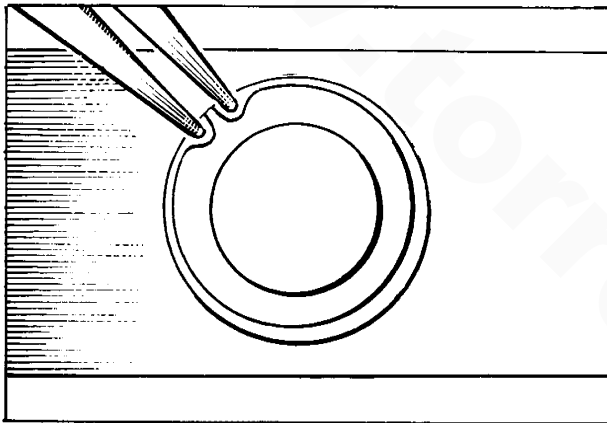

26. Main bearing caps

27. Main bearings

28. Thrust bearings

29. Crankshaft

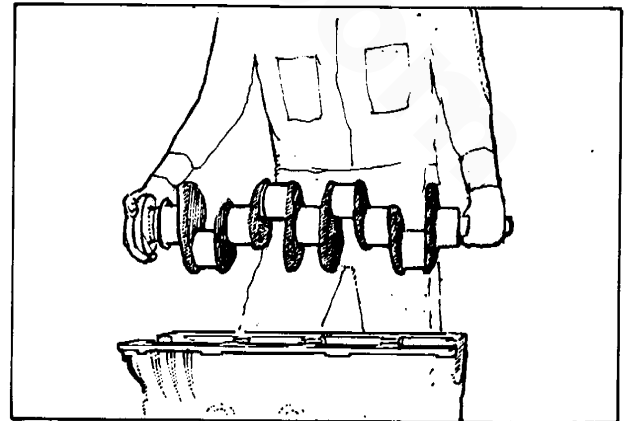

30. Tappets

NOTE: After removing the main bearings and bearing caps arrange them in order of removal. Do not mix caps.
After removing the thrust bearings, note their positioning for proper reinstallation.

www.torresen.com

ENGINE INSPECTION AND REPAIR

Checking Cylinder Head

1. Check the cylinder head for damage or cracks. If found, repair or replace the cylinder head.
2. Check the cylinder head for distortion. If it exceeds the limit, replace the cylinder head with a new one.

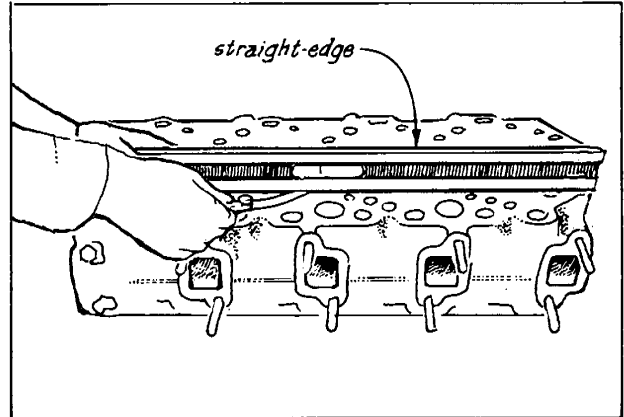
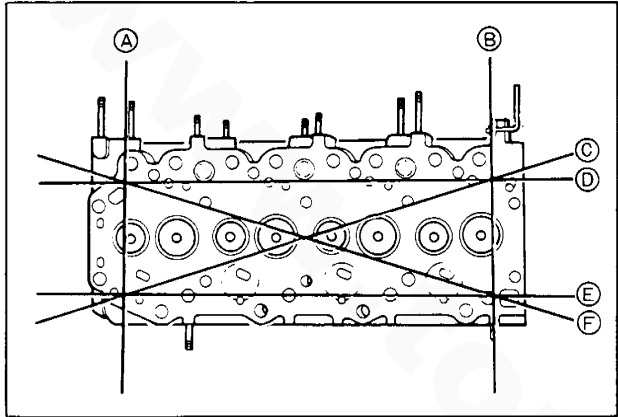

Maximum permissible distortion:

A, B	0.10 mm (0.004 in)
C, D, E, F	0.25 mm (0.010 in)

3. Check the insert for damage or cracks and, if detected, replace with a new one.

Replacing Combustion Chamber Insert

1. To remove the insert, place a suitable drift into the glow plug hole, then tap the drift with a hammer.
2. To install, set the insert in position and insert the welch washer into the insert guide hole. Secure the welch washer by tapping the raised center of the welch washer.

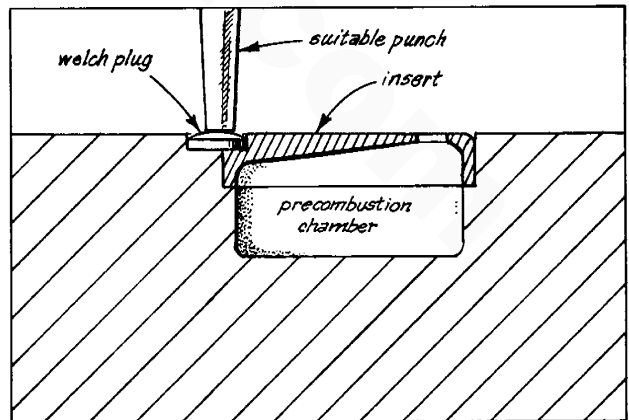

NOTE:

- (1) Use new welch washer.
- (2) Insert the welch washer so that its convex surface is toward the cylinder head gasket side.
- (3) After installation, check to see if the insert is completely fixed in place.

Checking Valve Spring

1. Check the spring for corrosion or damage. If it is defective, replace with a new one.
2. Check the spring length and replace the spring if the free length is less than the following dimension.

Free length limit:

W70:

Inner spring: 42.0mm (1.654in)

Outer spring: 52.9mm (2.083in)

W100:

Inner spring: 42.0mm (1.654in)

Outer spring: 43.6mm (1.717in)

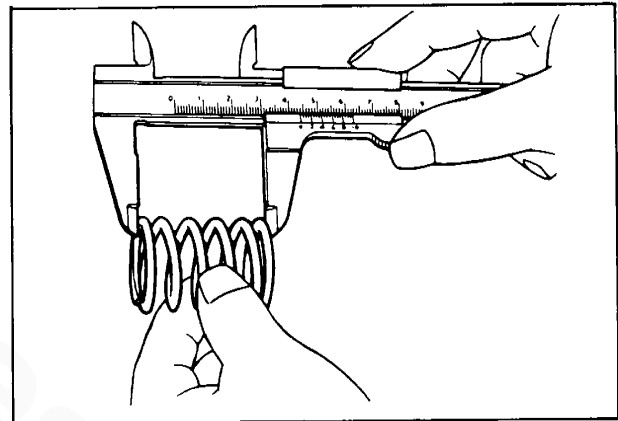

3. Check the squareness of valve spring. If it exceeds the limit, replace with a new one.

Squareness Limit:

Inner spring: 1.25mm (0.049in)

Outer spring: 1.37mm (0.054in)

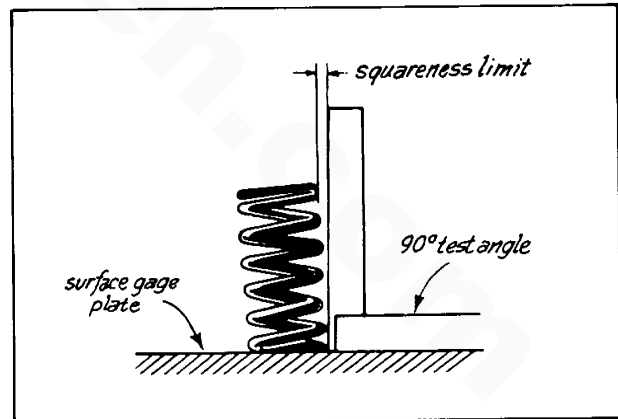

4. Check the fitting tension of the valve spring as follows:

- (a) Install the valve on a valve spring tester.
- (b) Measure the spring tension at the specified fitting length. If it is not within the specification, the spring must be replaced.

NOTE: Measure the spring tension after compressing the spring several times.

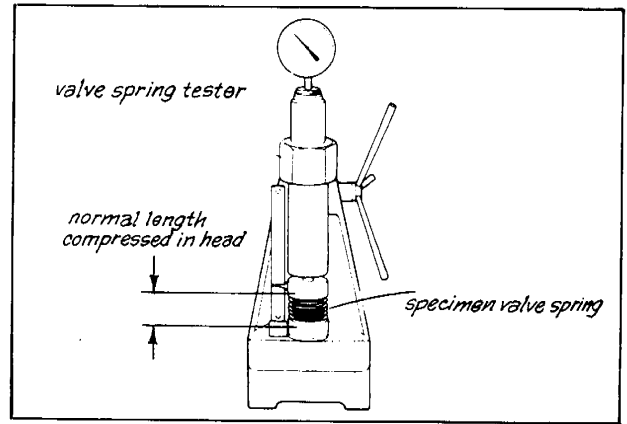

Fitting tension:

Fitting length	Inner 37.8 mm (1.488 in)	Outer 40.3 mm (1.587 in)
Fitting tension limit	11.3 kg (24.92 lb)	30.1 kg (66.36 lb)

Checking Valve

1. Check all valves for bends, cracks or excessive burning and replace them if any of these conditions are found.
2. Check the valve stem diameter with a micrometer; if the wear exceeds the limit, replace the valve.

Valve stem diameter limit:

- W70:
- Intake valve: 8.904 mm (0.351 in)
 - Exhaust valve: 8.884 mm (0.350 in)
- W100:
- Intake valve: 7.867 mm (0.310 In)
 - Exhaust valve: 7.854 mm (0.309 in)

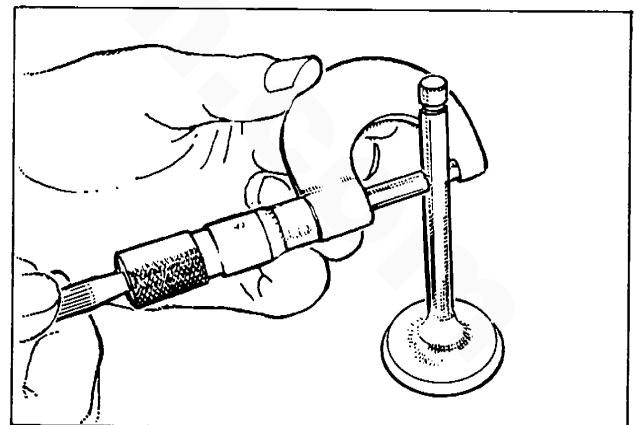

Checking Valve Guide

1. Check the clearance between the valve stem and guide with a mounted dial indicator by moving the valve stem from side to side. If the clearance exceeds the limit, replace the valve and guide.

Clearance Limit:

0.127 mm (0.0050 in)

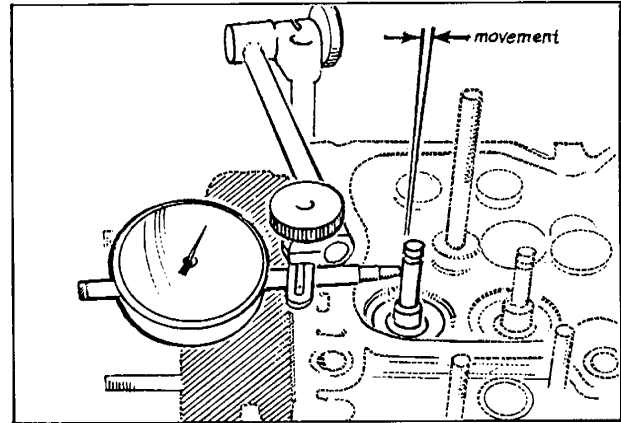

2. Check the protruding length of the valve guide. If it is not the specification, correct it.

Protruding length:

16.5 mm (0.65 in)

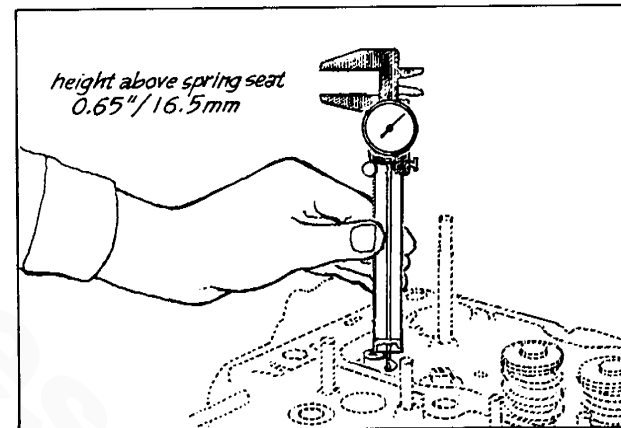

Replacing Valve Guide

1. To remove the valve guide, press out the guide with the valve guide installer, tool #49 0636 165 or its equivalent.
2. To install the valve guide press fit a new guide in the cylinder head with the valve guide installer and adapter, until the adapter comes in contact with the cylinder head.

NOTE: After installing the valve guide, check the protruding length of the valve guide.

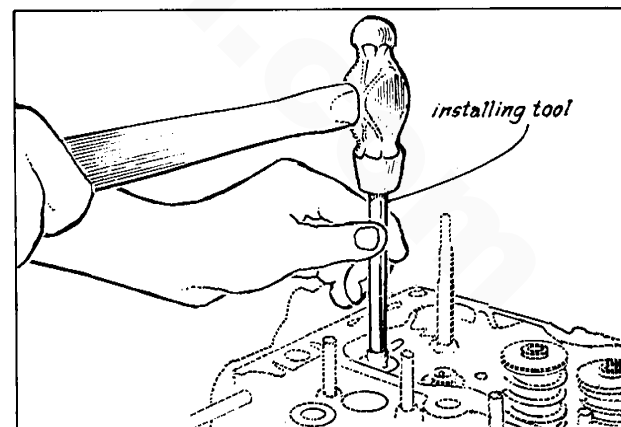

Checking Valve Seat

1. Check the protruding length of the valve stem (dimension "L"). If it exceeds the specification, correct it as follows.

Dimension "L" (standard):

W70: 48.05 mm (1.892 in)

W100: 48.04 mm (1.891 in)

When the dimension "L" is 0-0.5 mm (0 - 0.020 in) larger than the standard, it may be used as is.

When the dimension "L" becomes 0.5-1.5 mm (0.020-0.059 in) larger than the standard, replace the valve and adjust the dimension "L" to the standard by adding some washers (12.8 mm I.D. 39 mm O.D.) between the lower spring seat and cylinder head.

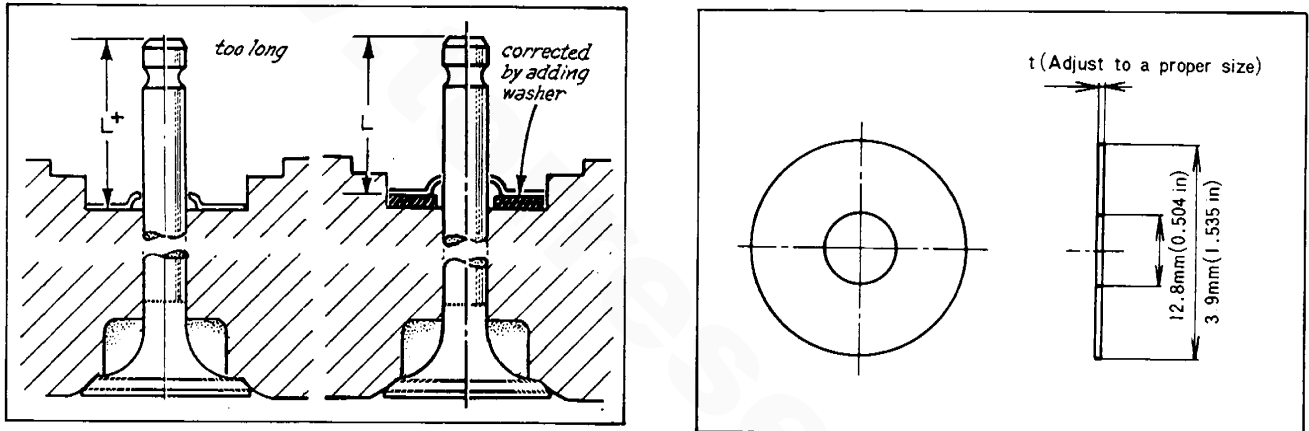

When the dimension "L" becomes more than 1.5 mm (0.059 in) larger than the standard, replace both the valve and cylinder head.

2. Check for contact between the valve and valve seat as follows:
 - a. Apply a thin coat of Prussian Blue (or Redlead) on the valve seat contact face.
 - b. Insert the valve into the valve guide and press fit the valve on the valve seat.

NOTE: Do not rotate the valve.

- c. Check if the valve seat contact face contacts the center position of the valve contact face. If the contact position is not centered, recut and surface the valve seat and valve.

Refacing Valve and Valve Seat

Reface in the following order:

1. Reface the valve with a valve grinder to the specified angle.

Valve face angle:

Intake valve	45°
Exhaust valve	30°

2. Reface the valve seat with a valve seat cutter while checking the contact between the valve and valve seat.

NOTE: Reface the valve seat taking care that the valve seat contacts the center position of the valve.

Valve seat angle	Intake 45°	Exhaust 30°
Valve seat width	2.0 mm (0.079 in)	2.0 mm (0.079 in)

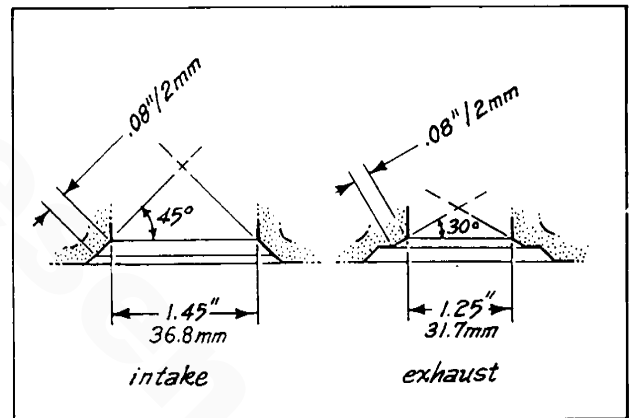
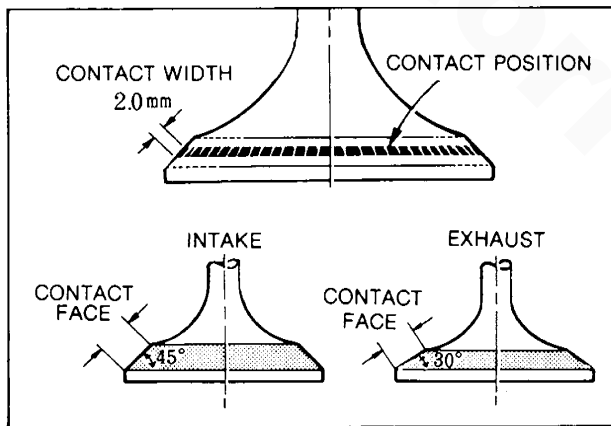

3. Reface the valve and valve seat with a good valve lapping compound.
4. Measure the dimension "L".
5. Adjust the dimension "L" to the standard by adding some washers between the lower spring seat and cylinder head.

Checking Rocker Arm and Shaft

1. Check each component part of the rocker arm assembly for damage or cracks. If necessary, replace with a new one.
2. Check to see that the oil passages of the rocker arm and shaft are open. If any clogs are found, remove them or replace.

3. Check the clearance between the rocker arm bore and shaft. If it exceeds the limit, replace the rocker arm bushing and shaft.

Clearance between rocker arm and shaft:

Standard	0.016 - 0.061 mm (0.0006 - 0.0024 in)
Limit	0.07 mm (0.0028 in)

Replacing Rocker Arm Bushing

1. To remove the rocker arm bushing, press out the old bushing with a suitable mandrel.
2. To install the rocker arm bushing, press fit a new bushing, aligning the oil holes of the bushing and rocker arm.
3. Finish the bushing with a spiral expansion reamer or a pin hole grinder so that the clearance between the bushing and shaft becomes equal to the standard clearance.

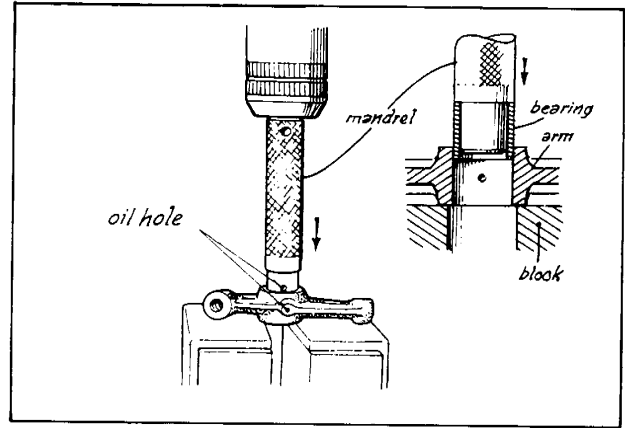

Checking Cylinder Block

1. Check the cylinder block for damage or cracks. If necessary, repair or replace the cylinder block.
2. Check to see that the oil passages and coolant passages of the cylinder block are open. If clogged, remove with compressed air or a wire probe.
3. Check the cylinder block for distortion. If it exceeds the limit, repair or replace the cylinder block.

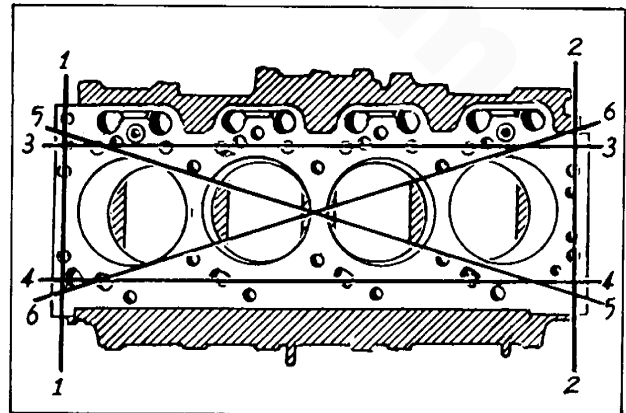
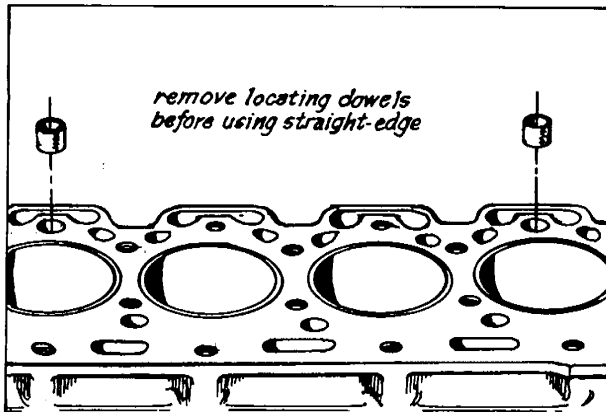

Maximum permissible distortion:

1, 2	0.10 mm (0.0039 in)
3, 4, 5, 6	0.25 mm (0.0098 in)

Checking Cylinder Liner

1. Check the cylinder liner bores for stretching and waviness.
2. Check the cylinder liner for wear with an inside micrometer. If it exceeds the limit, replace the cylinder liner.

NOTE: This measurement should be taken in the X-X direction and the Y-Y direction at each of the three sections: upper, middle and lower of each cylinder.

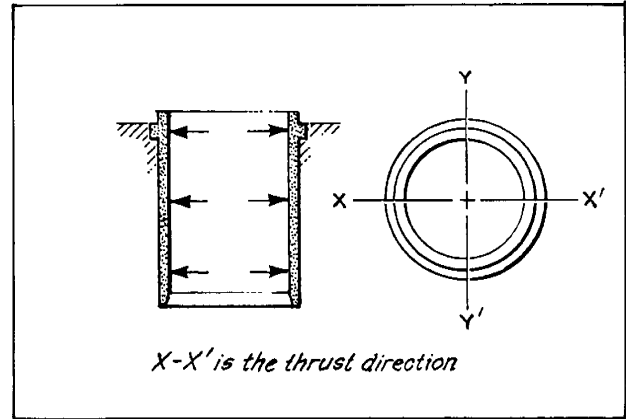

Cylinder liner bore:

Standard W70:	95.025 - 95.050 mm (3.7412 - 3.7422 in)
Standard W100:	92.025 - 92.050 mm (3.6231 - 3.6241 in)
Wear Limit:	0.20 mm (0.0079 in)

3. Check the protruding height of the liner with a straight edge and a feeler gauge. If it exceeds the specified value, correct as necessary.

Protruding height:

-0.101 - 0 mm (-0.0040 - 0 in)

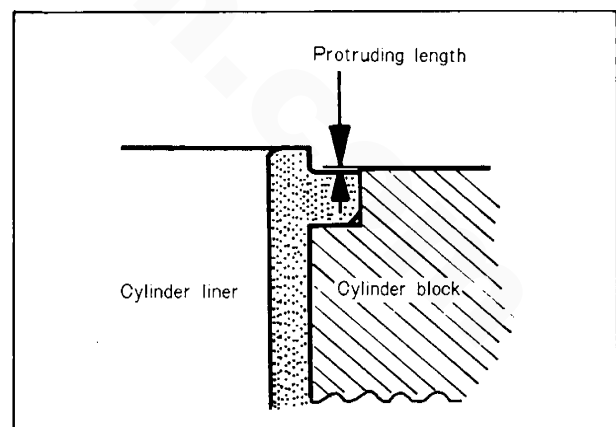

Replacing Cylinder Liner

1. Removal

- (a) Press out the liner with the cylinder liner replacer.
- (b) Check the cylinder block bore for any scratches. If any scratches are found, remove the scratches with oil soaked fine emery paper.

2. Installation

- (a) Apply engine oil on the cylinder block bore and a new liner outer surface and set the liner on the cylinder block.
- (b) Press fit the liner with the cylinder liner replacer taking special care not to distort it.

NOTE: When inserting the liner into the cylinder block, press fit it within the limits of 1.0 - 3.0 tons (2000 - 6000 lbs). If the pressing force required exceeds the limits, find the trouble and correct it. After installing the liner, check the protruding height of the liner.

Checking Piston

1. Check the piston carefully and replace if it is severely scored, scratched or burned.
2. Check the clearance between the piston and cylinder liner bore. If it is excessive, the piston and liner must be replaced.

NOTE: Measure the piston diameter at 90 degrees (perpendicular) to the pin bore axis and 22 mm (0.866 in) for the W70 or 23 mm (0.906 in) for the W100 from the piston bottom.

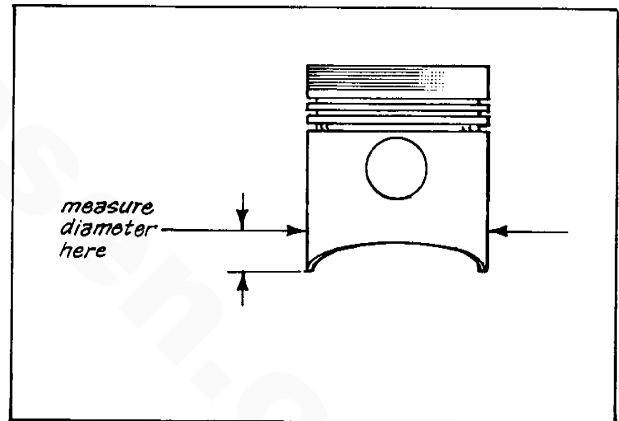

Piston Diameter:

W70:	94.967 - 94.993 mm (3.7381 - 3.7399 in)
W100:	91.967 - 91.993 mm (3.6208 - 3.6218 in)

Piston to Liner Clearance:

0.032 - 0.083 mm (0.0017 - 0.0028 in)

Checking Piston Rings

1. Check the piston rings for cracks, burning or wear. If any of these conditions exist, replace the ring.
2. Check the side clearance of the piston rings at several places. If they exceed the limit, replace the piston rings or piston.

Side clearance limit: 0.30 mm (0.0118 in)

3. Check the piston ring end gap as follows:

- (a) Place the piston ring in the cylinder liner bore below the ring travel by using a piston head to push the ring in squarely.
- (b) Measure the piston ring end gap. If it exceeds the limit, replace the piston ring.

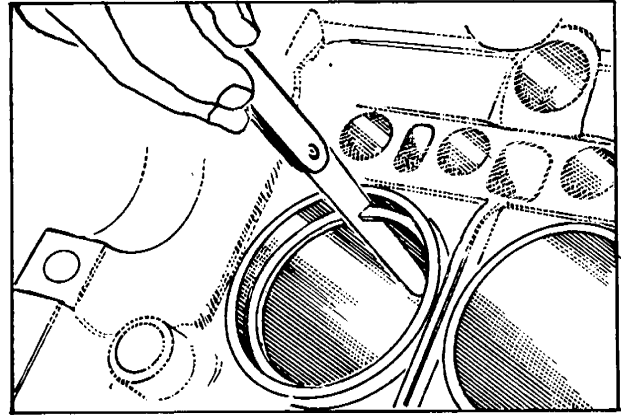

End gap limit:

1.5 mm (0.0591 in)

Checking Piston Pin and Connecting Rod Bushing

1. Check the clearance between the piston pin and connecting rod bushing. If it exceeds the limit, replace the piston pin and bushing.

Clearance between piston pin and bushing:

Standard W70:

0.012 - 0.039 mm
(0.0005 - 0.0015 in)

Standard W100:

0.014 - 0.044 in
(0.0006 - 0.0020 in)

Limit: 0.05 mm (0.0020 in)

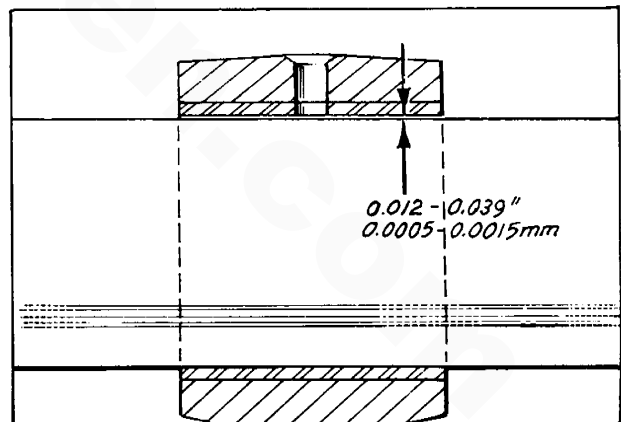

Replacing Connecting Rod Bushing

1. To remove the connecting rod bushing, press out the old bushing with suitable mandrel.
2. To install the connecting rod bushing, press fit a new bushing aligning the oil holes of the bushing and connecting rod.
3. Finish the bushing with a spiral expansion reamer or a pin hole grinder to the standard clearance specified.

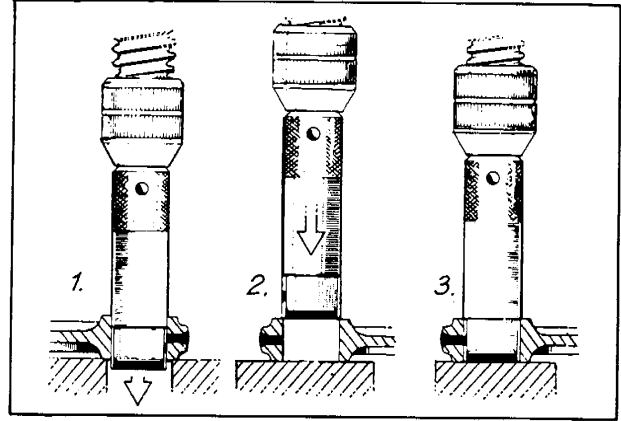

NOTE: When reaming the bushing, correctly insert the reamer in the bushing. In order to prevent unevenness on the bushing surface, the reaming should always be made in the cutting direction. Make sure that the reamer is stopped at different positions at all times.

When correcting the smaller end bushing of the connecting rod with a pin hole grinder, the hole is apt to become tapered. Therefore, be sure to change the direction of the connecting rod several times while honing until the specified size is obtained.

Checking Connecting Rod

1. Check the side of the connecting rod small end and large end for cracks or damage. If necessary, replace the connecting rod.
2. Check the connecting rod for bends or twists with a suitable alignment fixture. If realignment is necessary, correct by using a press and applying a gradual pressure to the rod or replace the connecting rod.

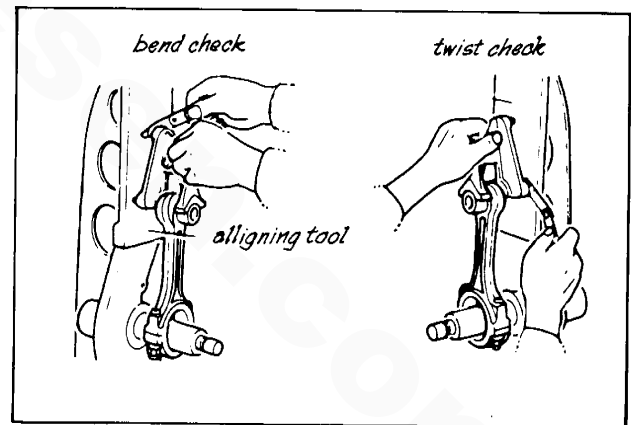

Permissible deflection: 0.05 mm per 100 mm (0.0020 in per 4 in)

3. Check the connecting rod side play with a dial indicator or a feeler gauge as shown in the figure. If it exceeds the limit, replace the connecting rod or crankshaft.

End play limit:

0.4 mm (0.0157 in)

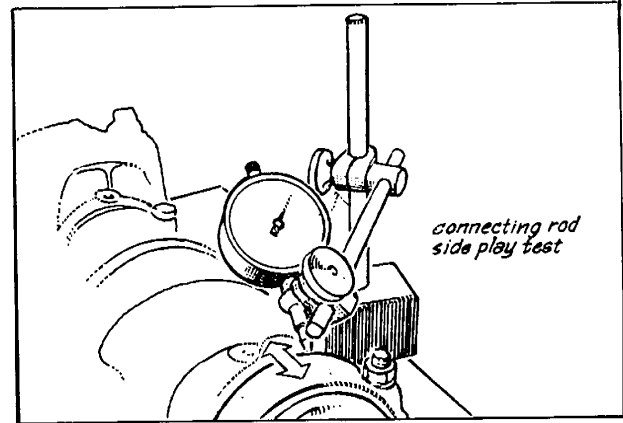

Checking Connecting Rod Bearing

1. Check the connecting rod bearing carefully and replace if it is worn, scored or flaked.
2. Check the connecting rod bearing clearance with a "plastigauge". If it exceeds the limit, correct the crankpins with a suitable grinder and use with suitable undersize bearings.

NOTE: Tighten the connecting rod cap bolts to the specified torque.

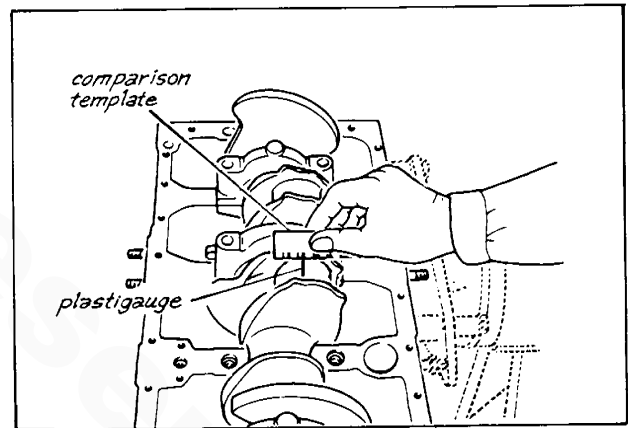

Cap tightening torque:

W70: 7.8 - 8.0 kg-m (56.41 - 57.86 lb-ft)

W100: 7.6 - 8.3 kg-m (54.97 - 60.03 lb-ft)

Bearing clearance:

Standard W70: 0.012 - 0.031 mm (0.0005 - 0.0012 in)

W100: 0.014 - 0.044 mm (0.0006 - 0.0017 in)

Limit: 0.05 mm (0.0020 in)

Checking Crankshaft

1. Check the crankshaft for cracks or other damage. If necessary, replace the crankshaft.
2. Check to see that the oil passages of the crankshaft are open. If any clogs are found, remove them with compressed air or a suitable wire.
3. Check the crankshaft for wear. If it exceeds the limit, correct the crankshaft with a suitable grinder and use with suitable undersize main bearings.

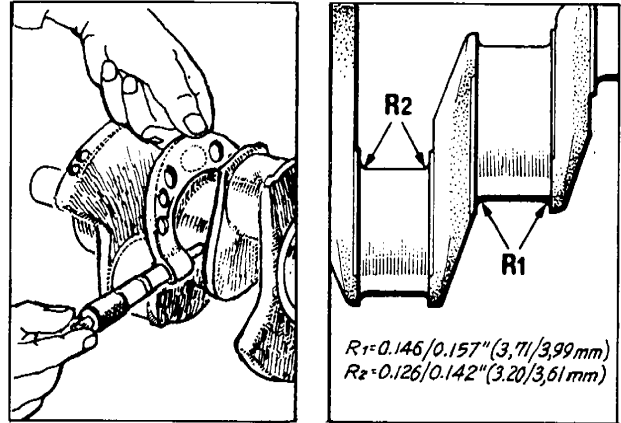

NOTE: Measure the diameter of each of the crankpins and main journals at two points (the front and rear portions) at 90 degrees to the crankshaft axis, as shown in figure.

	W70 Main journal	W70 Crankpin
Standard	75.812 - 75.825 mm (2.9848-2.9853 in)	61.112 - 61.125 mm (2.4060-2.4065 in)
Undersize 0.254	75.558 - 75.571 mm (2.9748-2.9753 in)	60.868 - 60.871 mm (2.3964-2.3965 in)
Undersize 0.508	75.304 - 75.317 mm (2.9648-2.9674 in)	60.604 - 60.617 mm (2.3874-2.3865 in)
Undersize 0.762	75.050 - 75.063 mm (2.9578-2.9554 in)	60.350 - 60.363 mm (2.3760-2.3765 in)
	W100 Main Journal	W100 Crankpin
Standard	69.812 - 69.825 mm (2.7485-2.7491 in)	57.112 - 57.125 mm (2.2485-2.2491 in)
Undersize 0.254	69.558 - 68.571 mm (2.7385-2.7391 in)	56.868 - 56.871 mm (2.2389-2.2391 in)
Undersize 0.508	69.0304- 69.317 mm (2.7182-2.7291 in)	56.604 - 56.617 mm (2.2285-2.2312 in)
Undersize 0.762	69.050 - 69.063 mm (2.7185-2.7191 in)	56.350 - 56.363 mm (2.2185-2.2191 in)
Wear limit	0.05 mm (0.0020 in)	0.05 mm (0.0020 in)

NOTE: When grinding the crankshaft, take care of the following points.

- (a) When grinding the crankshaft, finish the place of "R" as shown in figure.
- (b) The crankshaft processing diameters are as shown in the table above.

4. Check the crankshaft alignment. If it exceeds the limit, replace with a new one.

Maximum allowable run-out:

0.05 mm (0.0020 in)

5. Check the crankshaft end play with a dial indicator or a feeler gauge as shown in the figure. If it exceeds the limit, replace the thrust bearing with an oversized thrust bearing of 0.178 mm (0.007 in).

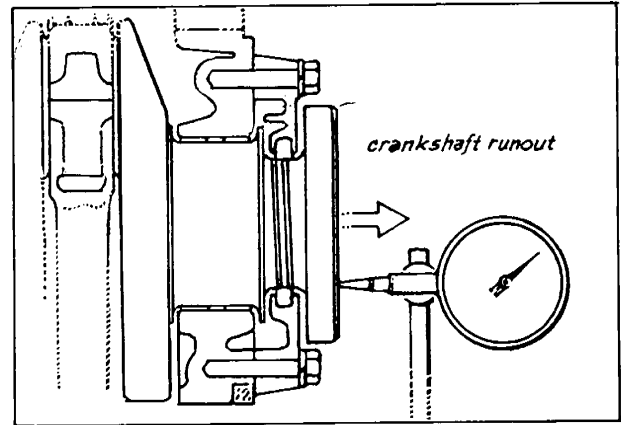

End play limit: 0.40 mm (0.0157 in)

Note: Any crankshaft grinding should be done at a qualified machine shop.

Checking Main Bearing

1. Check the main bearing carefully and replace if it is worn, scored or flaked.
2. Check the main bearing clearance with a "plastigauge". If it exceeds the limit, correct the main journals by having the crankshaft ground for undersized main bearings.

NOTE: Tighten the main bearing cap bolts to the specified torque.

Cap tightening torque:

11.0 - 11.7 kg-m (80 - 85 lb-ft)

Bearing Clearance:

Standard: 0.059 - 0.090 mm (0.0023 - 0.0035 in)

Limit: 0.12 mm (0.0047 in)

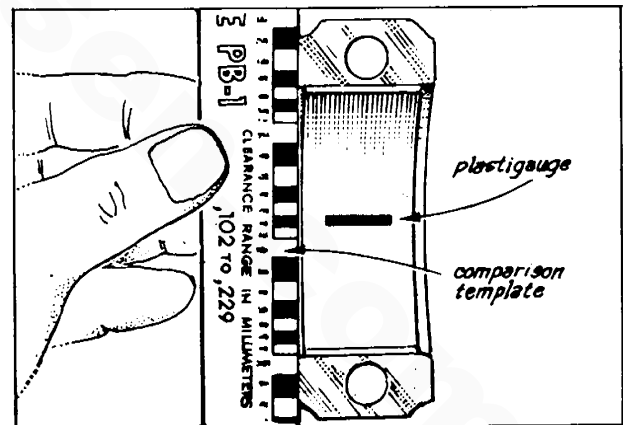

Checking Camshaft

1. Check the camshaft for damage or cracks. If necessary, replace the camshaft.

NOTE: If the damage is slight, you may be able to correct the camshaft with an oil soaked fine emery grindstone. Correct the camshaft with special care so as not to damage the original cam form.

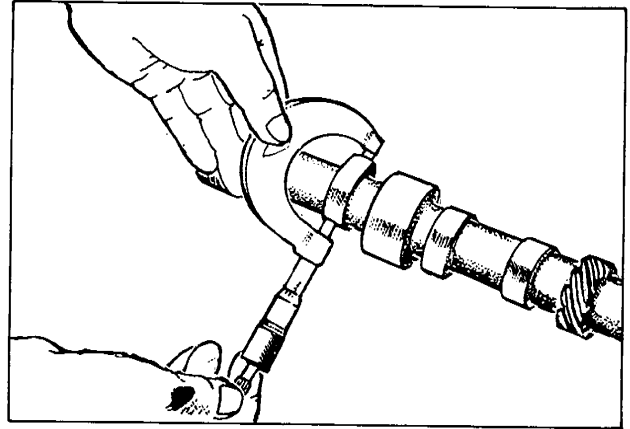

2. Check the cam height and replace the camshaft if the wear exceeds the limit.

Cam height limit W70: 42.478 mm (1.6724 in)
 W100: 42.485 mm (1.6727 in)

3. Check the camshaft journal for wear. If it exceeds the limit, replace the camshaft.

	Journal diameter	Wear limit
No. 1	51.910 - 51.940 mm (2.0437 - 2.0449 in)	0.008 mm (0.0003 in)
No. 2	51.660 - 51.690 mm (2.0339 - 2.0350 in)	0.008 mm (0.0003 in)
No. 3	51.410 - 51.440 mm (2.0240 - 2.0252 in)	0.008 mm (0.0003 in)
No. 4	51.160 - 51.190 mm (2.0142 - 2.0154 in)	0.008 mm (0.0003 in)

4. Check the clearance between the camshaft journal and camshaft support bore as follows.

(a) Measure the camshaft journal diameter and camshaft support bore.

(b) Calculate the clearance and replace the camshaft or cylinder block if the clearance exceeds the limit.

Clearance limit: 0.145 mm (0.0057 in)

5. Check the camshaft alignment. If it exceeds the limit, replace with a new one.

Maximum allowable run-out: 0.08 mm (0.0031 in)

6. Check the camshaft end play as follows.

- (a) Install the thrust plate, camshaft gear, friction gear, lock plate and camshaft gear lock bolt on the camshaft.
- (b) Tighten the lock bolt to the specified torque.

Tightening torque:

W70: 6.4 - 9.5 kg-m
46 - 69 lb-ft)

W100: 6.2 - 7.0 kg-m
(45 - 51 lb-ft)

- (c) Measure the clearance between the thrust plate and camshaft. If it exceeds the limit, replace the thrust plate.

End play limit:

0.30 mm (0.0118 in)

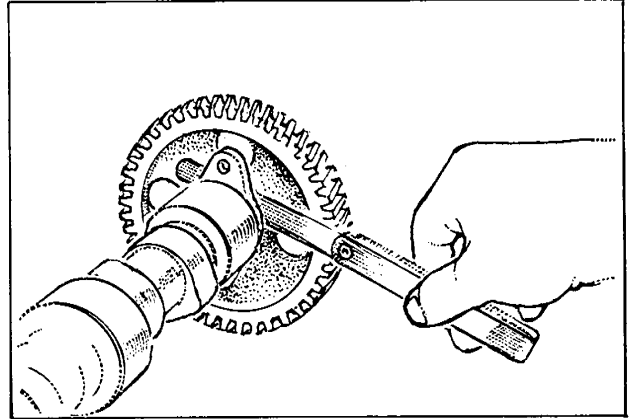

Checking Idler Gear Bushing and Spindle

- 1. Check the bushing and spindle for wear or damage and replace if necessary.
- 2. Check the oil passages of the spindle for clogging and, if necessary, clean the passage with compressed air or wire.
- 3. Check the clearance between the bushing and spindle by measuring the bushing bore and spindle diameter. If it exceeds the limit, replace the bushing or spindle.

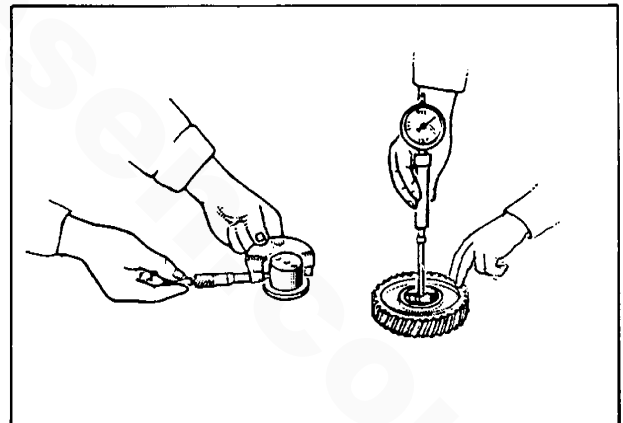

Clearance between bushing and spindle:

Standard: 0.034 - 0.084 mm
(0.0013 - 0.0034 in)

Limit: 0.15 mm (0.0059 in)

Replacing Idler Gear Bushing

- 1. To remove the idler gear bushing, press out the old bushing with a suitable mandrel.

2. To install the idler gear bushing, press fit a new bushing with a suitable mandrel.
3. Finish the bushing with a spiral expansion reamer or a pin hole grinder to assure the correct fit.

Checking Gears

1. Check the gears (idler gears, injection pump drive gear, crankshaft gear, camshaft gear) for cracks or damage. If necessary, replace as required.
2. Check the idler gear end play as shown in figure. If it exceeds the specified value, replace the thrust plate or idler gear.

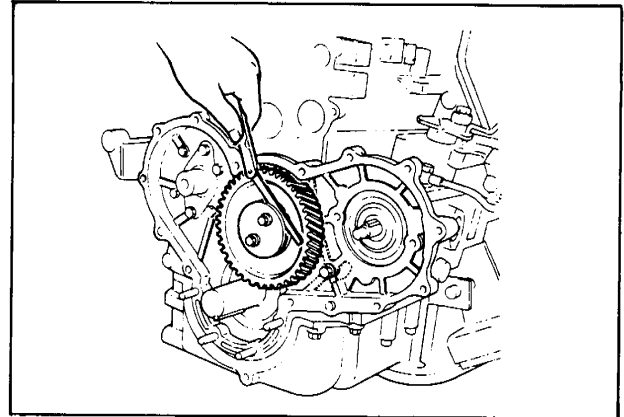

NOTE: Measure the end play after tightening the idler gear attaching nuts to the specified value.

Thrust plate tightening torque: 2.3 - 3.2 kg-m (17 - 23 lb-ft)

End play standard: 0.15 - 0.30 mm (0.0059 - 0.0118 in)

3. Check the backlash of every gear with a dial indicator.

NOTE: Check the backlash after assuring that the idler gear end play and the clearance between the idler gear bushing and spindle are within standard.

Backlash standard: 0.10 - 0.20 mm (0.0039 - 0.0079 in)

Backlash limit: 0.30 mm (0.0118 in)

Checking Push Rod

1. Check the push rod ends for damage. If any damage is found, replace it.
2. Check the push rod for bends with the corner of a surface of a surface plate. If it exceeds the limit, replace with a new one.

Bend Limit: 0.19 mm (0.0075 in)

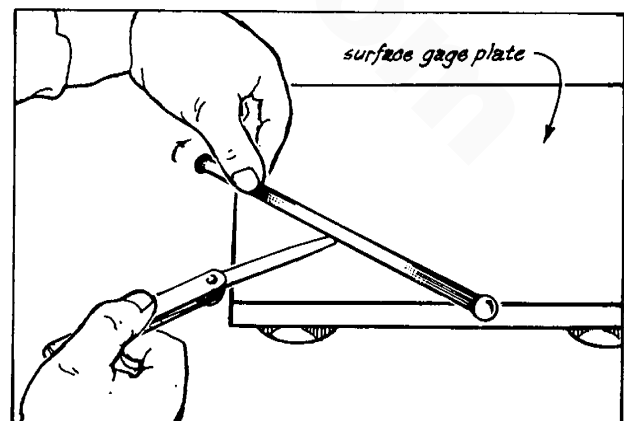

Checking Tappet

1. Check the tappet for cracks or damage. If damaged, replace the tappet.
2. Check the contact surface of the tappet with the cam for wear. If it is abnormal, replace the tappet.
3. Check the clearance between the tappet and tappet guide. If it exceeds the limit, replace the tappet or cylinder block.

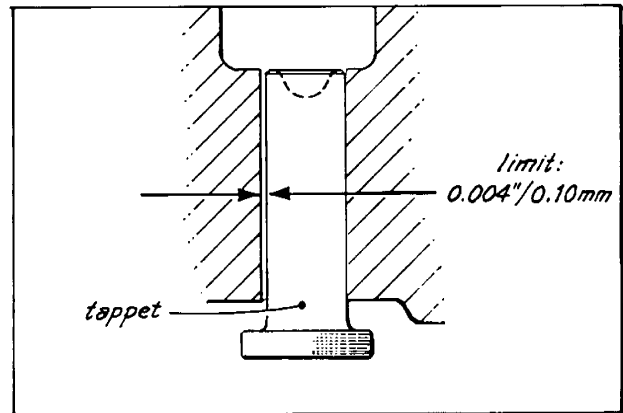

Clearance limit:

0.10 mm (0.0039 in)

Checking the Timing Gear Cover Oil Seal

1. Check the lip of the oil seal for wear or damage. Replace as required.

Replacing Timing Gear Cover Oil Seal

1. To remove the timing gear cover oil seal, press out the old seal with a suitable oil seal puller and installer.
2. To install the timing gear cover oil seal, apply engine oil onto the outside of a new seal and press fit the seal with an oil seal puller and installer until the installer comes in contact with cover.

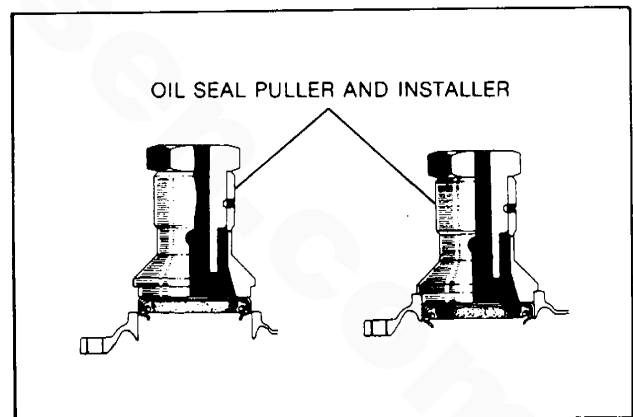

Checking Rear Oil Seal

1. Check the lip of the oil seal for wear or damage. Replace as required.

Replacing Rear Oil Seal

1. To remove the rear oil seal, strike out the old seal with a suitable mandrel.
2. To install the rear oil seal, apply engine oil onto the outside of a new seal and press fit the seal in the rear oil seal cap equally.

NOTE: In case the crankshaft is worn, the oil seal must be fitted on the oil seal cap with its fitting position moved by approximately 3 mm so that the seal does not touch the worn-down portion of the crankshaft.

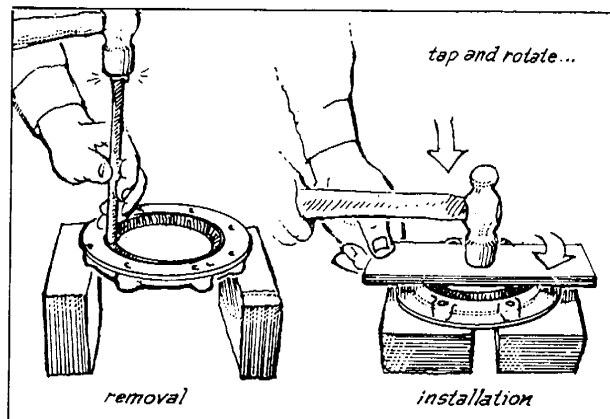

ENGINE ASSEMBLY

Take the following precautions:

- A. Be careful not to mix nuts and bolts. Metric and S.A.E. bolts are used on various engine assemblies.
- B. During assembly, recheck clearances and insure parts are being assembled in their proper order and facing in the correct direction in relation to the engine block, e.g., pistons, piston rings, bearings and bearing caps.
- C. Apply lubricating oil to moving parts during assembly. Insure that moving parts, when assembled on the engine, rotate or slide and are not subject to binding or excessive tension.
- D. If there are mating marks scribed during disassembly, reference them correctly for assembly.
- E. Use new gaskets, lockwashers, o-rings, etc.
- F. Tighten the bolts and nuts on important parts of engine to specified torques using a reliable torque wrench.
- G. Use liquid sealants when required on nuts, bolts and gaskets. Refrain from using tape sealants.

Assembling Engine

Assemble in the following order:

1. Intake and exhaust valves. Use a suitable valve spring compressor.

NOTE: Apply engine oil onto the sliding section of the valve stem. Insert the oil deflector on the intake valve only.

2. Rocker arm assembly. Note that the front end of the rocker shaft is identified by a pin protruding from the top and a larger oil hole between the supply holes. This pin fits a slot in the #1 rocker shaft support which prevents the shaft from turning and cutting off the lube oil to the rocker arms and valves.

- a. Spring
- b. Rocker arm
- c. Rocker bracket
- d. Rocker arm
- e. Wave washer
- f. Stop ring

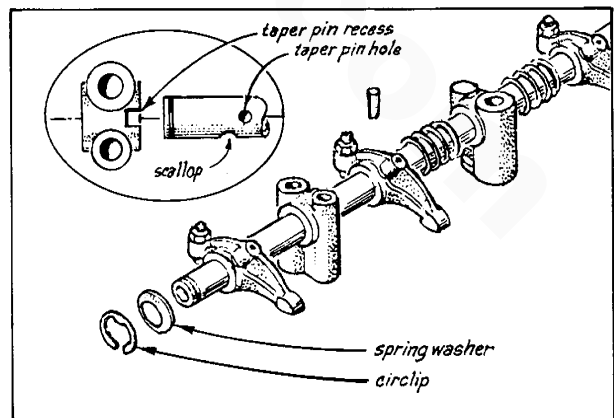

3. Piston and connecting rod.
 - a. Piston pin (wrist pin)
 - b. Snap ring

NOTE: Assure that the connecting rod locking groove faces the piston front as shown in figure.

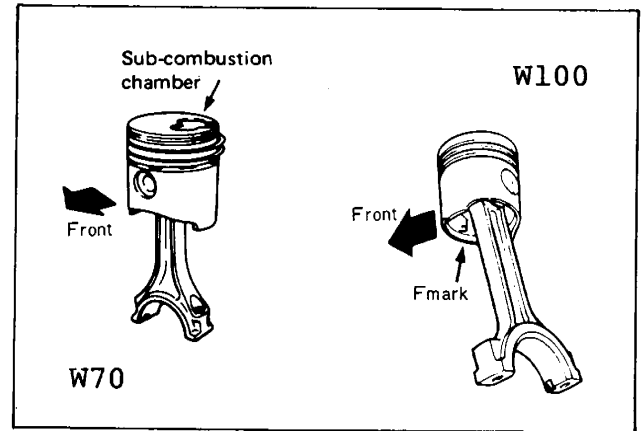
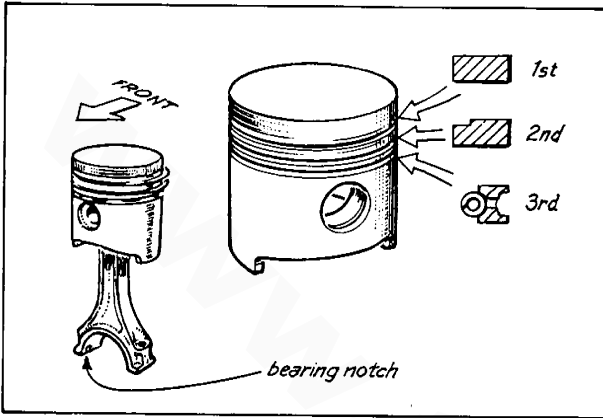

4. Piston rings. Use a suitable piston ring expander.

NOTE: Install the piston ring with the inscription mark upward towards the piston crown.

5. Main Bearings.

NOTE: Install the main bearings in their proper position. Apply engine oil onto the surface of the main bearing. Do not apply oil onto the back side of the main bearing. Insure that the bearing oil ports are properly aligned and that the lock tab of the bearing is mating properly with the lock groove in the block.

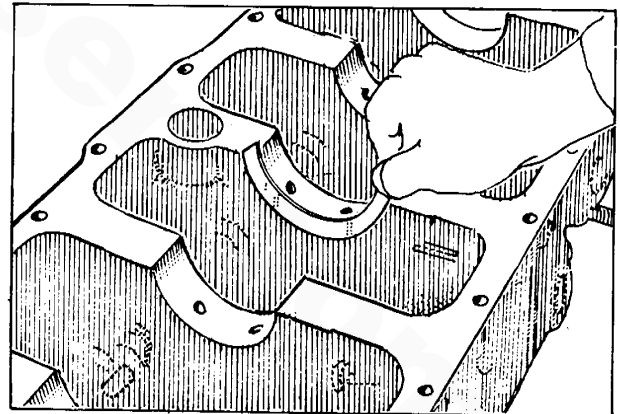

6. Thrustwashers.

NOTE: Fit the thrustwashers with the oil groove side facing outward.

7. Crankshaft. Be careful that the thrustwashers do not drop as the crankshaft settles in place.

8. Main bearing caps.

NOTE: Fit the thrust bearing (with flange) with the oil groove side facing outward. The arrow mark of the cap top should face towards the front of the engine.

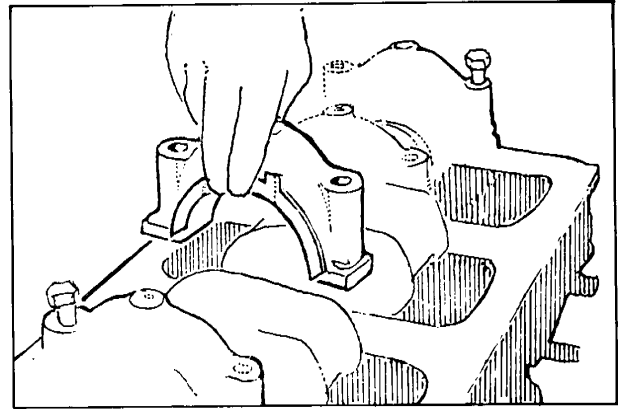

9. Cap bolts.

NOTE: Make sure that the crankshaft rotates smoothly after installing.

Tightening torque: 11.0 - 11.7 kg-m (80 - 85 lb-ft)

10. Rear oil seal assembly.

NOTE: Apply engine oil onto the lip of the seal. Install a gasket between the oil seal assembly and cylinder block. Use a good quality gasket cement when installing this gasket.

11. Piston and connecting rod assemblies. Use a suitable piston ring compressor.

NOTE: Install the piston and connecting rod assembly in the position as shown in figure. Apply engine oil onto the sliding face of the piston and cylinder bore.

NOTE: Place the piston rings at about 90° apart as shown in figure. Place the top and second rings in the opposite direction against the pre-combustion chamber.

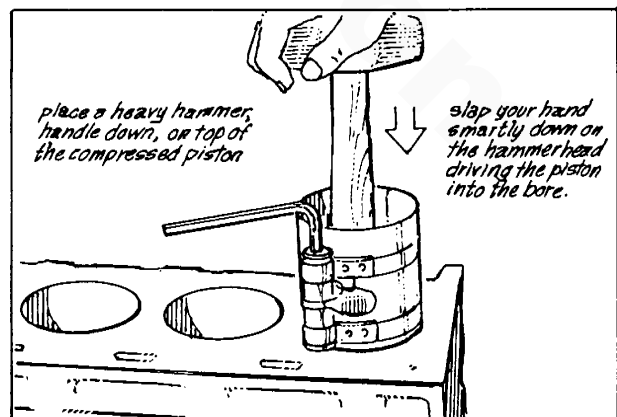
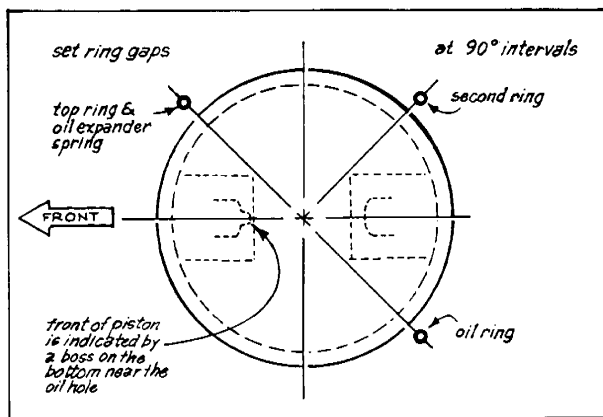

12. Connecting rod caps.

NOTE: Apply engine oil onto the surface of the connecting rod bearing prior to installing.

Insure that the rod caps are properly matched to the proper rod.

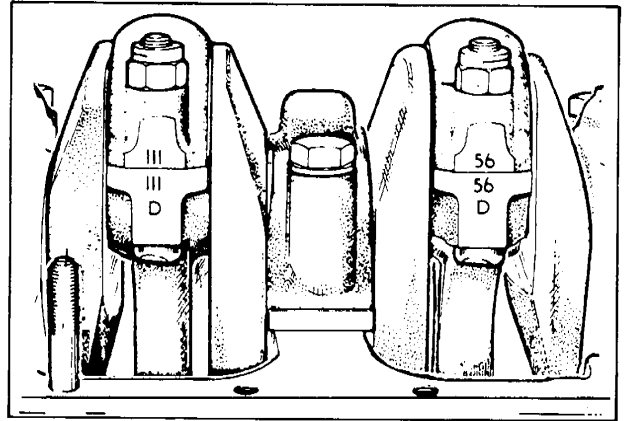

13. Connecting rod cap bolts.

Tightening torque:

W70: 8.2 - 9.0 kg-m (59 - 65 lb-ft)
W100: 7.6 - 8.3 kg-m (55 - 60 lb-ft)

14. Tappets.

NOTE: Apply engine oil onto the sliding face of the tappet.

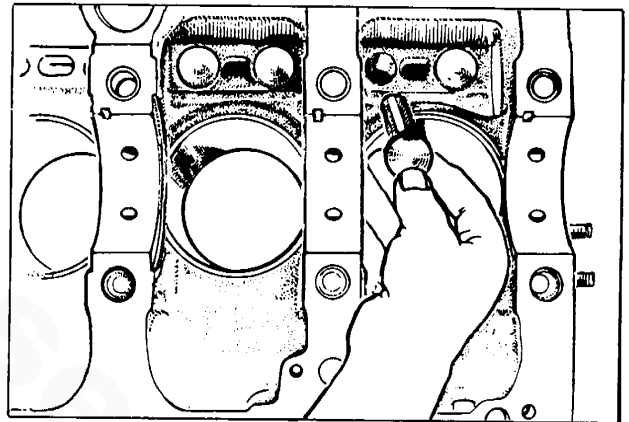

15. Camshaft and thrust plate.

NOTE: Apply engine oil onto the camshaft journal and bearing surfaces.

Tightening torque:

1.6 - 2.4 kg-m
(12 - 17 lb-ft)

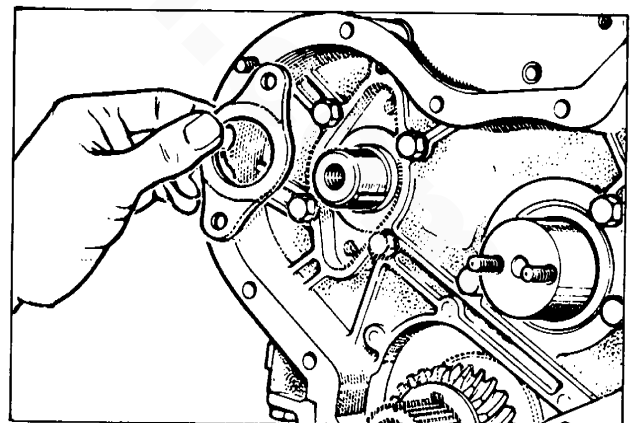

16. Idler gear spindle.

NOTE: Align the oil holes.

17. Fuel injection pump.

NOTE: It is easier to first install the injection pump to the timing gear case and then the entire assembly onto the engine. Install the injection pump aligning the identification marks.

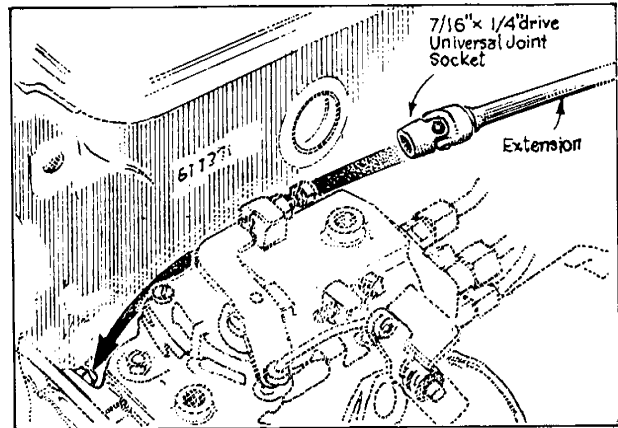
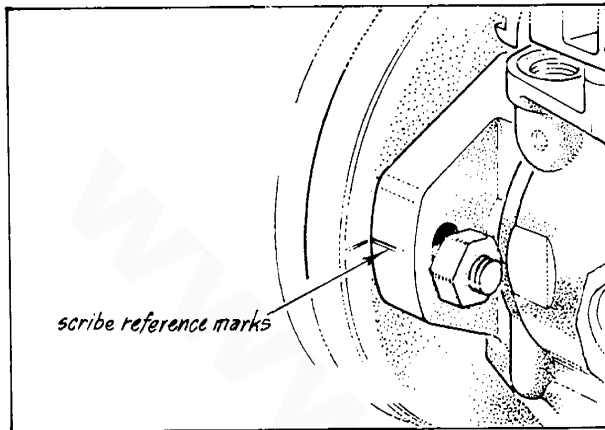

18. Timing gear case

NOTE: Align the end face of the timing gear case and cylinder block. Cut off the excess gasket.

Tightening torque:

1.6 - 2.4 kg-m (12 - 17 lb-ft)

19. Gears.

- a. Camshaft gear
- b. Injection pump drive gear
- c. Crankshaft gear
- d. Idler gear

NOTE: Align the timing gear marks of every gear.

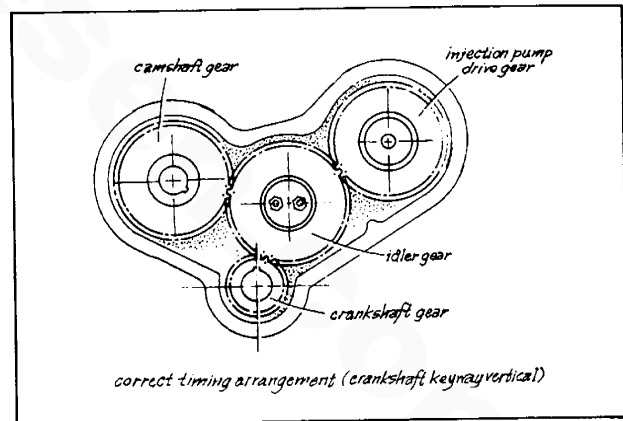

20. Idler gear thrust plates and attaching nuts

Tightening torque:

2.3 - 3.2 kg-m (17 - 23 lb-ft)

21. Friction gears.

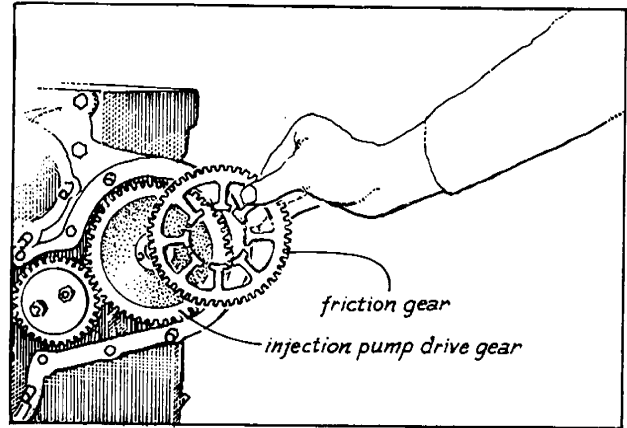

22. Camshaft gear lock bolt.

NOTE: Wedge a clean cloth between the camshaft gear and idler gear.

Tightening torque:

W70: 6.4 - 9.5 kg-m (46 - 69 lb-ft)

W100: 6.2 - 7.0 kg-m (45 - 51 lb-ft)

23. Injection pump drive gear lock nut.

NOTE: Wedge a clean cloth between the injection pump drive gear and idler gear.

Tightening torque:

4.0 - 7.0 kg-m (29 - 51 lb-ft)

24. Oil deflector on crankshaft.

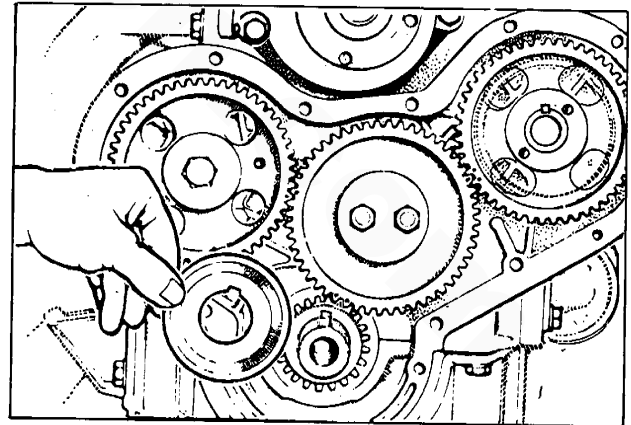

25. Timing gear cover.

Use the oil seal puller and installer to aid in installing the timing gear front engine cover.

Tightening torque:

1.6 - 2.4 kg-m (12 - 17 lb-ft)

26. Oil pump assembly.

NOTE: Make sure that the oil pump drive gear and driven gear mesh.

27. Oil pan gaskets.

NOTE: Place the ends of gasket (A) on the gaskets (B) and (C). Apply gasket cement on the contact portions of the gaskets and on the contact portions of the timing gear case and cylinder block.

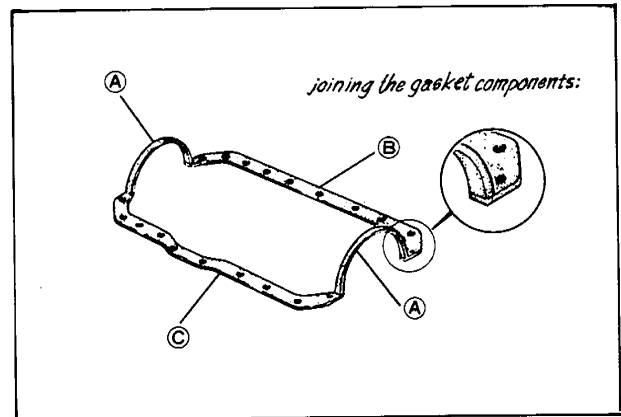

28. Oil pan upper block.

NOTE: Make sure that the fitting surfaces of rear sides of the cylinder block and oil pan upper block are kept flush.

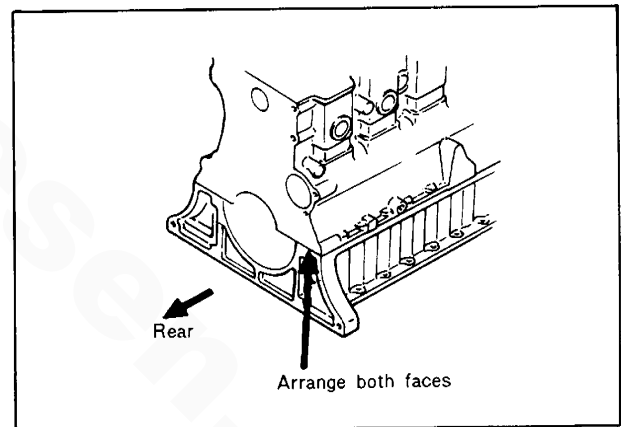

29. Oil pan.

Tightening torque:

1.6 - 2.3 kg-m
(12 - 17 lb-ft)

30. Back plate.

Tightening torque:

3.3 - 4.8 kg-m (24 - 35 lb-ft)

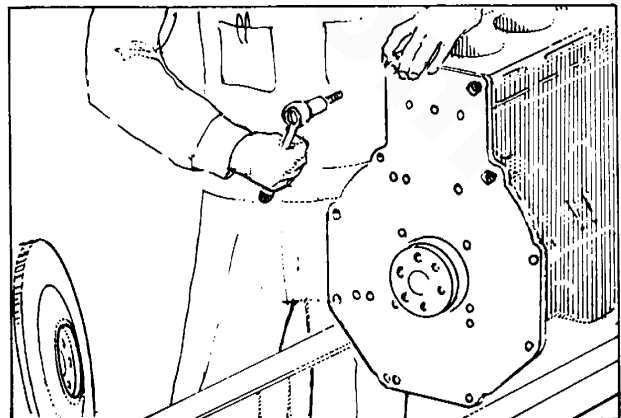

31. Flywheel.

NOTE: Install the flywheel by placing it on the crankshaft and rotating it to properly align the mounting bolt holes. Install the tabwasher and the attaching bolts. After torquing, bend one tab against a flat of each attaching bolt.

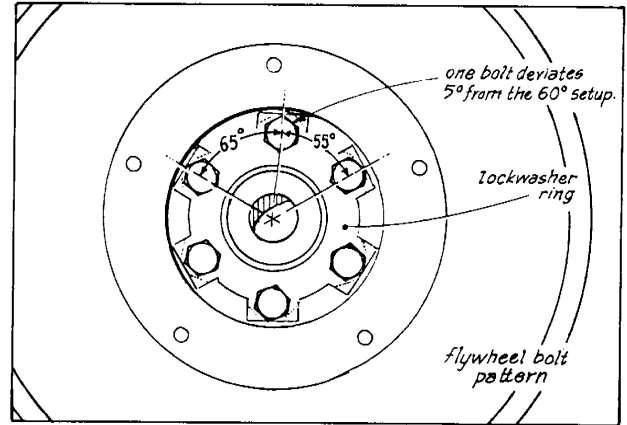

Tightening torque:

15.5 kg-m (112 lb-ft)

32. Crankshaft pulley.

NOTE: Apply engine oil onto the lip of oil seal. Carefully slide the front crankshaft pulley onto the crankshaft insuring that the key in the crankshaft and the keyway in the pulley mate properly. Apply Loctite (high temperature) to the threads of the front crankshaft pulley holddown bolt when installing it. Insure that the flat washer is under the head of the bolt when installed.

Tightening torque:

W70: 35 - 40 kg-m (253 - 289 lb-ft)

W100: 39 - 42 kg-m (282 - 304 lb-ft)

33. Tubular dowel pins.

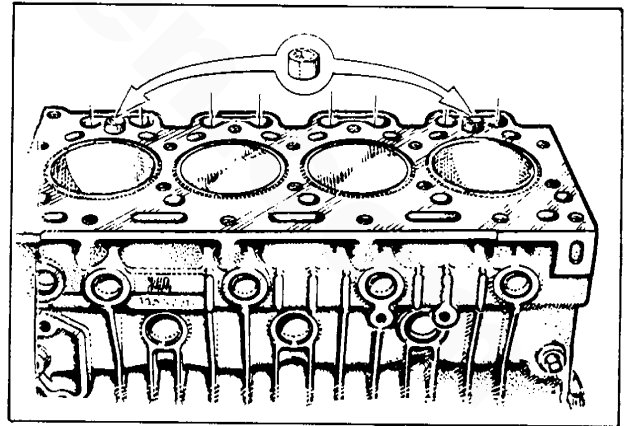

34. Cylinder head gasket.

35. Cylinder head.

36. Pushrods.

NOTE: Make sure that the pushrod seats securely in the tappet concavity.

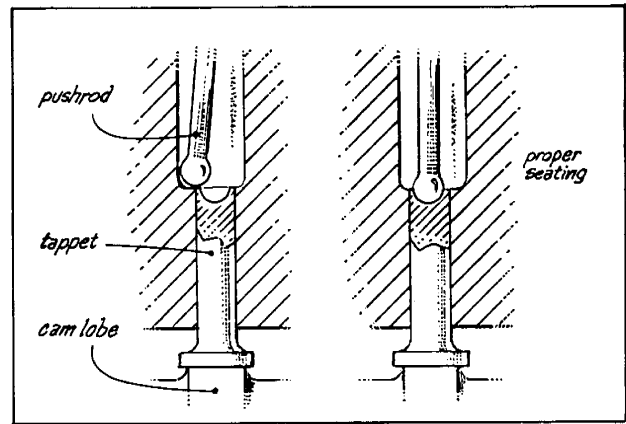

37. Valve caps on top of valve stems.

NOTE: Make sure that the valve cap is installed squarely on the valve stem.

38. Rocker arm assembly.

39. Cylinder head bolts.

NOTE: Tighten the cylinder head bolts in the order shown in the figure. After tightening the cylinder head bolts, make sure that the rocker arms move smoothly.

Tightening torque (cold engine)

W70: 11.8 - 12.5 kg-m (85 - 90 lb-ft)

W100: 11.0 - 11.7 kg-m (80 - 85 lb-ft)

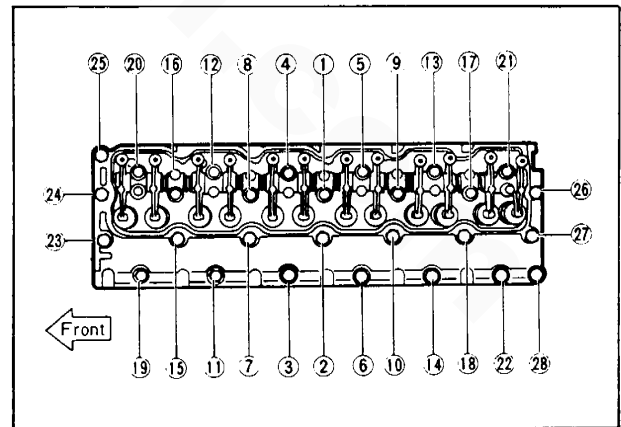
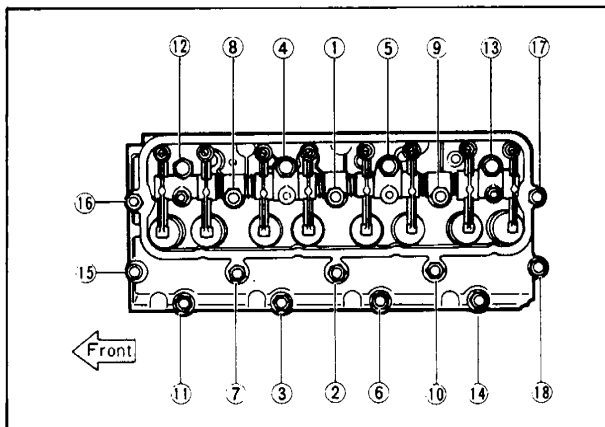

40. Adjust valve clearance.

W70:

Adjust the No. 1, 2, 3 and 6 valves when the No. 1 piston is coming up on compression stroke.

Next, when the No. 4 piston is coming up on compression stroke, adjust the No. 4, 5, 7 and 8 valves. The valves are numbered 1 - 8 from front of engine.

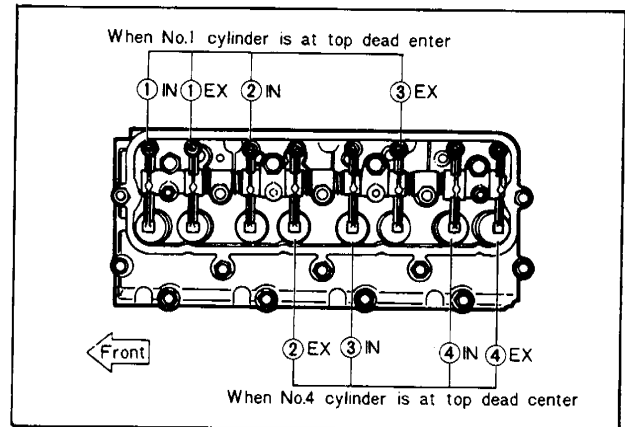

W100:

Adjust the No. 1, 2, 3, 6, 7 and 10 valves when the No. 1 piston is coming up on compression stroke.

Next, when the No. 6 piston is coming up on compression stroke, adjust the No. 4, 5, 8, 9, 11 and 12 valves. The valves are numbered 1 - 12 from the front of the engine.

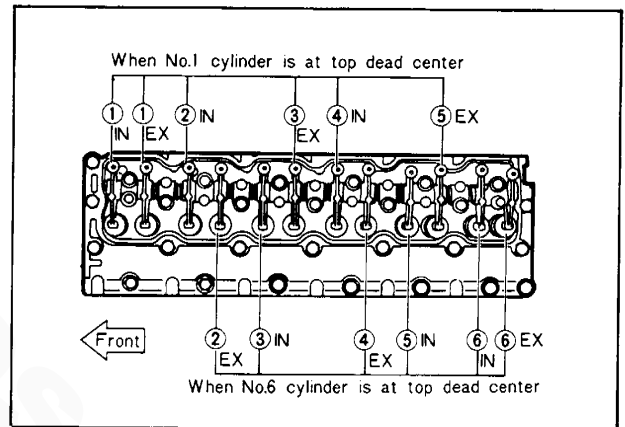

NOTE: When the engine is overhauled, run the engine under load to check its performance. Allow the engine to cool to room temperature and retorque the cylinder head holddown nuts and re-adjust valves.

The cylinder head holddown bolts and valve adjustment should be rechecked again after 50 hours and periodically thereafter.

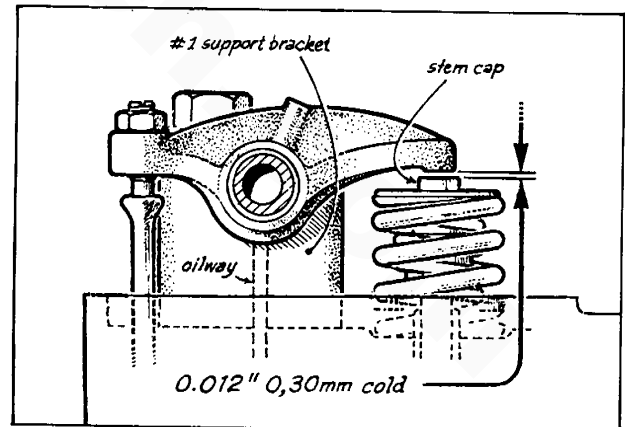

Valve Clearance (cold):

Intake	0.3 mm (0.012 in)
Exhaust	0.3 mm (0.012 in)

Installing Engine Equipment Parts

Install in the following order:

1. Fresh water pump assembly.

Tightening torque:

1.6 - 2.4 kg-m (12 - 17 lb-ft)

2. Water return pipe on W100.
3. Checking injection timing.

- (a) Remove the valve cover if already reinstalled.
- (b) Place piston No. 1 at T.D.C. of its compression stroke.

NOTE: No. 1 piston is the first piston from the front of the engine.

- (c) Remove the snap circlip on the end of the rocker shaft. Slacken the rocker arm adjusting nut to allow the rocker arm to be removed from the shaft. This will expose the No. 1 valve.
- (d) Remove the valve cap and keepers and springs. This will allow the valve to drop down on to the piston head which is at top dead center of its compression stroke.

- (e) Attach a dial indicator gauge to the engine and zero it on the top flat portion of the valve stem. Find exact T.D.C. of No. 1 piston by carefully rocking the crankshaft back and forth. Once this is found, re-zero the dial indicator.

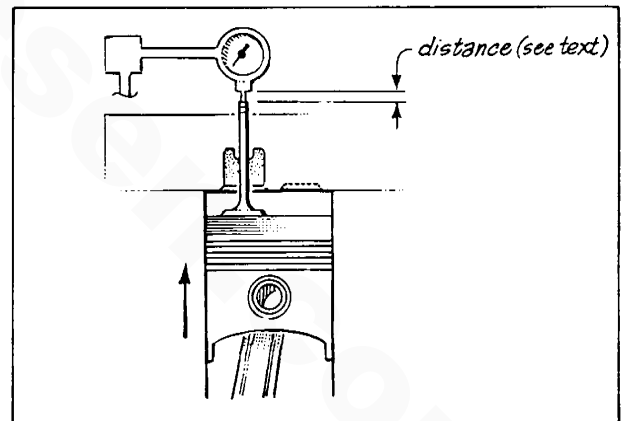

- (f) Slowly turn the crankshaft in the opposite direction of normal rotation until the indicator reads $0.230 \pm .005$ inches B.T.D.C. for the W100 or $0.180 \pm .005$ inches for the W70. It is advisable to go slightly more than 0.230 (0.180) and then return to that figure to remove gear lash. The No. 1 piston is now at 30 degrees B.T.D.C.
- (g) The injection pump is already installed on the engine. Verify that the scribe mark on the injection pump outboard mounting flange is properly aligned with the scribe mark on the engine mounting case.
- (h) Remove the plug and sealing washer from the aft center of the

injection pump. (This is the plug located centrally where the four high pressure injector lines attach to the pump.)

- (i) Install in the place of this plug the #49 9140 074 measuring device. Insure that the measuring device rod contacts the plunger inside the pump and zero the gauge.

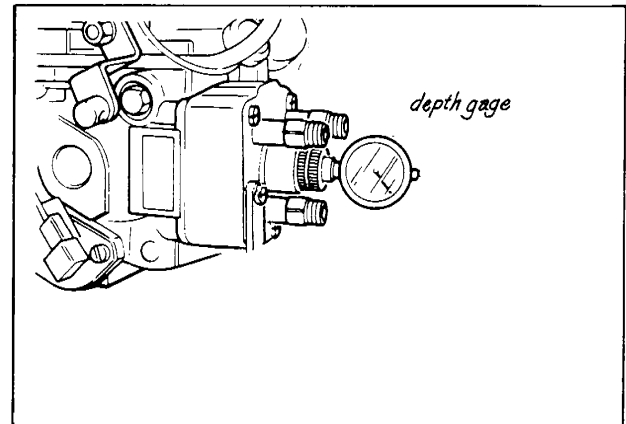
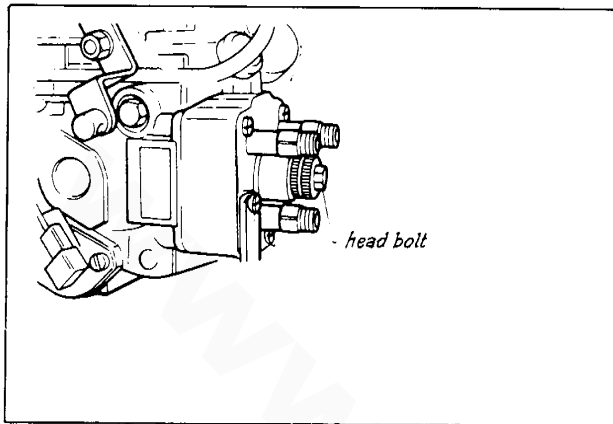

NOTE: When setting the dial gauge, confirm that the dial gauge pointer does not deviate from the scale mark of zero by slightly turning the engine crankshaft from left to right.

- (j) Turn the engine crankshaft in the normal direction of rotation to bring the No. 1 piston up to T.D.C. The dial indicator on the valve stem should zero and the indicator on the injection pump should show 1 mm (0.039 inches) of movement.

4. Adjusting injection timing.

- (a) Loosen the nuts holding the injection pump to the engine. (High pressure injector lines should not be attached to the injection pump.)
- (b) Make the adjustment by moving the injection pump itself. When the amount of movement of the measuring device indicator on the injection pump is too large, first turn the injection pump in the reverse direction of the engine rotation so that the dial gauge pointer indicates less than the scale mark of 1 mm. Then turn the injection pump in the direction of the engine rotation so that the measuring device indicator points to the scale mark of 1 mm.

NOTE: Above adjusting procedures are to make the gear backlash tight.

When the amount of the measuring device indicator on the injection pump is too small, turn the injection pump in the direction of engine normal rotation so that the measuring device indicator points to the scale mark of 1 mm (0.039 in.).

- (c) After the adjustment, tighten the injection pump holddown nuts, and then confirm again that the adjustment has been done correctly.

5. Checking cam lift.

- (a) Turn the crankshaft in the normal direction of rotation and read the maximum value which the dial indicator pointer on the measuring device shows. This is the cam lift.

Amount of cam lift: 2.2 mm (0.08 in)

- (b) After this check, remove the measuring device and install the plug and sealing washer.
- (c) When the injector high pressure lines are reinstalled, they will have to be bled of air as well as the injection pump itself. Bleed the injection pump first by loosening the return connection (a) and evacuating the air from the injection pump by supplying fuel to the injection pump by priming with the lever on the engine mounted fuel filter until fuel clear of air passes out this connection. These high pressure lines are bled next by loosening them at their attachment to the fuel injectors. Loosen their attaching nuts on all four lines one to two turns. Turn the key on and crank the engine over with the starter until fuel spurts by the nuts and the lines. Stop cranking and tighten attaching nuts and start engine in the usual manner.

6. Intake manifold.

Tightening torque:

1.6 - 2.4 kg-m (12 - 17 lb-ft)

7. Fuel injectors and return lines.

NOTE: The copper sealing washers should not be reused.

Injector tightening torque:

W70: 6.0 - 7.0 kg-m (43 - 51 lb-ft)
W100: 1.6 - 2.4 kg-m (12 - 17 lb-ft)

8. Glow plugs.

9. Rocker cover with new gasket.

NOTE: Apply sealant to that portion of the gasket that contacts the cover only.

10. Front engine mounts.

11. Oil filter and mounting bracket.

12. Fresh water circulating pump pulley.

13. Sea water pump, bracket and pulley.

- 14. Alternator and bracket.
- 15. Sea water pump belt.
- 16. Alternator belt.
- 17. High pressure fuel injector lines.
- 18. Bellhousing.
- 19. Starting motor.

20. Damper plate to flywheel.

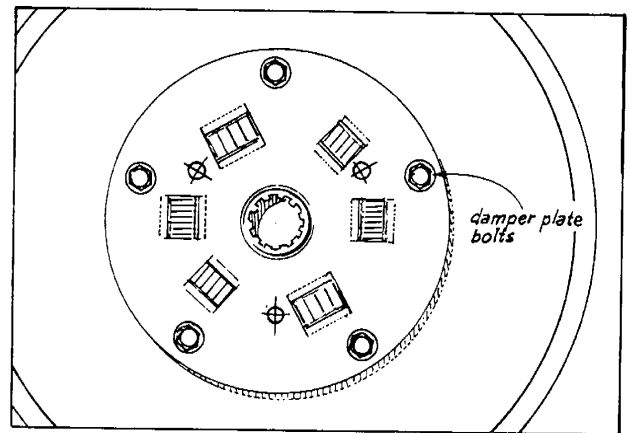

21. Transmission and related coolers and hardware as applicable.

22. Adjust "V" belt tension.

"V" belt deflection (exerting 10 kg force):

For new belt: 9 - 11 mm
(0.35 - 0.43 in)

For used belt: 10 - 12 mm
(0.39 - 0.47 in)

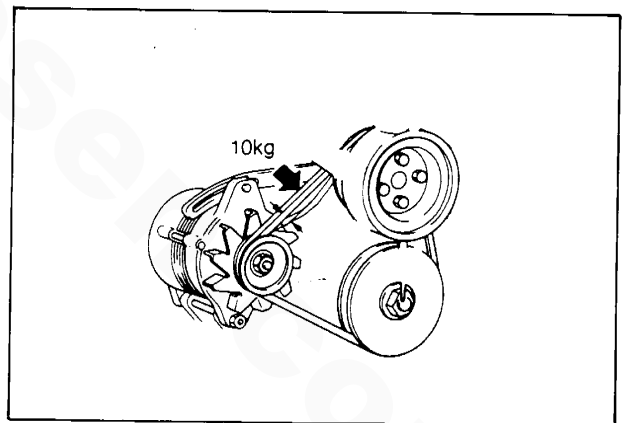

23. Install the exhaust manifold - expansion tank in its entirety.

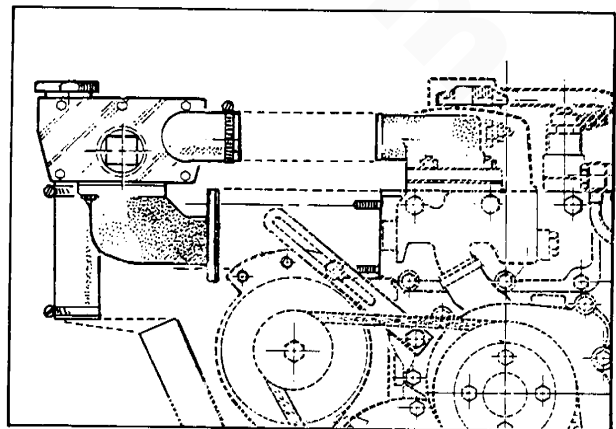

24. Thermostat and thermostat housing.
25. Install engine heat exchanger and lube oil cooler on engine bellhousing with related hardware.
26. Replace preheat solenoid and circuit breaker and mounting bracket.
27. Crankcase vent hose.

28. Oil and water senders and switches.

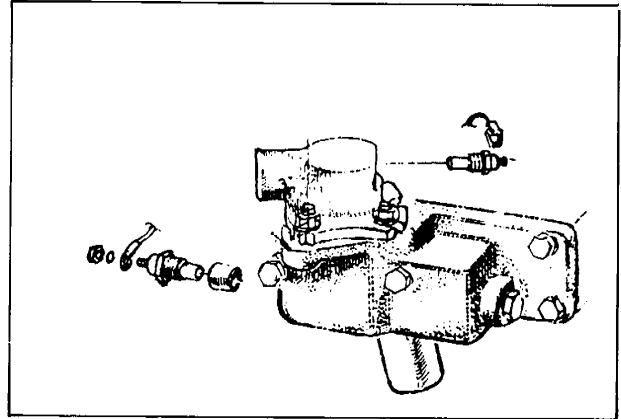

29. Engine wiring harness.
30. Engine mounted fuel filter and related lines.
31. Engine dipstick tube and dipstick.
32. Air intake silencer.
33. Install the preformed metal tube with supports from the exhaust manifold/expansion tank to the inlet side of the fresh water circulating pump.
34. Install new hose connections and clamps for cooling system.
35. Fill transmission with proper lubricant.
36. Fill the engine cooling system with antifreeze mixture.
37. Fill engine oil sump with lube oil (A.P.I. Spec. CC or better).

The engine should be test run under load prior to reinstalling. Allow the engine to cool to room temperature and retorque the cylinder head bolts and check valve clearances.

CHECKING COMPRESSION PRESSURE

NOTE: Before measuring the compression pressure, check the valve clearance and the charge of batteries and starting motor as well as for proper cable sizes and connections to and from the engine.

1. Warm up the engine.
2. Remove all fuel injectors.
3. Disconnect the fuel shut off solenoid wire.
4. Install the adapter in the injector hole.
5. Connect a compression tester on the adapter and crank the engine with the starting motor until the pressure reaches a maximum value.

Compression pressure:

Standard 30.0 kg/cm² (427 lb/in² at 200 RPM)

Limit 27.0 kg/cm² (384 lb/in² at 200 RPM)

6. If the compression pressure is greater than the standard, but the pressure difference between any pair of cylinders exceeds 3 kg/cm² (42.7 lb/in²), disassembly and repair are necessary.

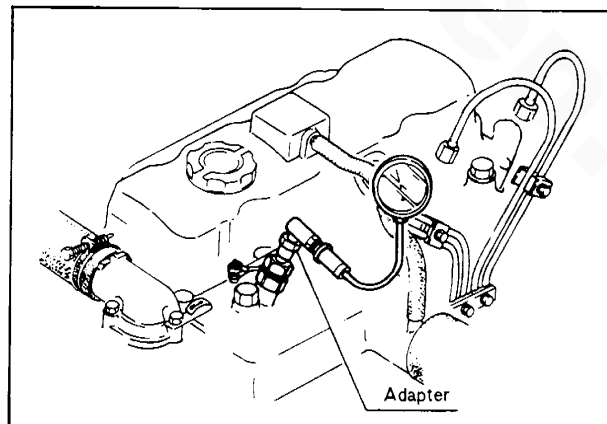

LUBRICATING SYSTEM

Operation

The lubricating system is a pressure feeding system using an oil pump. The engine oil forced out of the oil pump is passed through the oil filter. The oil passes through the oil filter and the engine lube oil cooler and then to the various lubricating points in the engine and then returns to the lube oil sump.

When the oil pressure exceeds the specified pressure, the oil pushes open the relief valve in the oil pump and returns to the oil pan, thereby keeping the oil pressure within its specified range.

Checking Engine Oil

1. Check for any engine oil leakage. Should leakage be detected, correct as needed. Tightening of fittings and bolts is considered normal maintenance and is the responsibility of the owner.
2. Check engine oil level with the lube oil dipstick at least once daily prior to engine usage. Add oil as needed.
3. Make sure that the oil is higher than the mid point between the "F" and "L" marks of the dipstick. If found lower than the "L" mark, replenish up to the "F" mark.

NOTE: Maintaining proper engine oil level is the responsibility of the engine owner/operator. Any damage to the engine due to lack of adequate oil is the responsibility of the owner/operator. Gauges and alarms are provided to warn against loss of proper engine oil pressure. Monitoring of engine operating gauges is the responsibility of the owner/operator.

Engine oil capacity:

Oil Sump	W70:	6.0 liters	(6.3 U.S.quarts) (5.3 Imp quarts)
	W100:	11.3 liters	(11.9 U.S.quarts) (9.9 Imp quarts)

Checking Oil Pressure

1. Warm up the engine.
2. Remove the oil pressure sender and connect a mechanical oil pressure gauge instead.
3. Set the engine speed at 3600 RPM and measure the oil pressure. If the oil pressure is less than the specification, check the lubricating system.

Oil pressure:

Greater than 3.8 kg/cm²
(54.04 lb/in²) at 3600 RPM

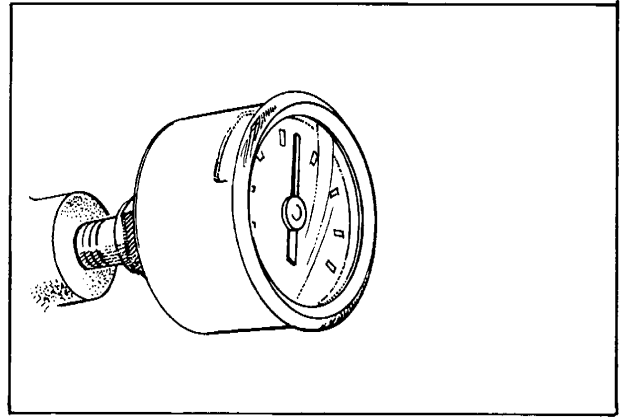

NOTE: Insure proper oil is being used that meets temperature requirements and the A.P.I. spec. of CC or better.

4. If the oil pressure drops below the specified safe minimum pressure of 0.3 + 0.1 kg/cm² (4.3 + 1.4 lb/in²), an immediate check should be made.

Removing Oil Pump

Remove in the following order:

1. Oil pan
2. Oil pump set screw
3. Oil pipe attaching bolts
4. Oil pump

Disassembling Oil Pump

Disassemble in the following order:

W70:

1. Oil pipe and gasket
2. Oil strainer and gasket
3. Oil pump cover
4. Outer rotor
5. Pump body, inner rotor and gear assembly
6. Drive gear. Use a press and a suitable mandrel.
7. Inner rotor
8. Oil pump body
8. Relief valve assembly
 - (a) Screw
 - (b) O-ring
 - (c) Spring
 - (d) Steel ball

W100:

1. Oil pipe and gasket
2. Oil strainer and gasket
3. Drive gear
4. Pump cover
5. Drive shaft
6. Outer rotor
7. Relief valve assembly

Checking Oil Pump

1. Check the clearance between the lobes of the rotors with a feeler gauge. If the clearance exceeds the limit, replace both rotors.

Clearance limit: 0.3 mm (0.0118 in)

2. Check the clearance between the outer rotor and pump body with a feeler gauge. If the clearance exceeds the limit replace the rotor or pump body.

Clearance limit:

0.3 mm (0.0118 in)

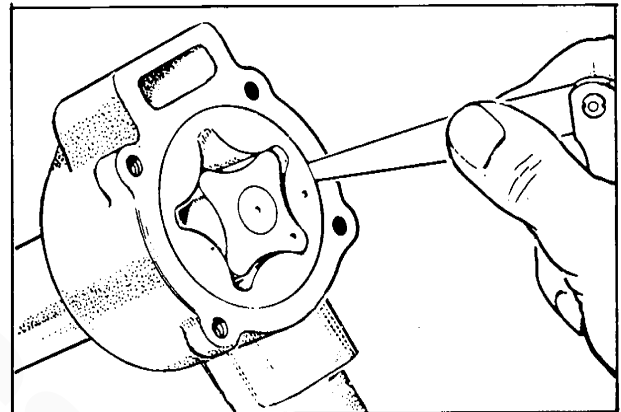

3. Check the end float of the rotors. Place a straight edge across the pump body and measure the clearance between the rotor and straight edge with a feeler gauge. If the clearance exceeds the limit, replace the drive gear, drive shaft, inner rotor, outer rotor and pump body.

Clearance limit:

0.15 mm (0.0059 in)

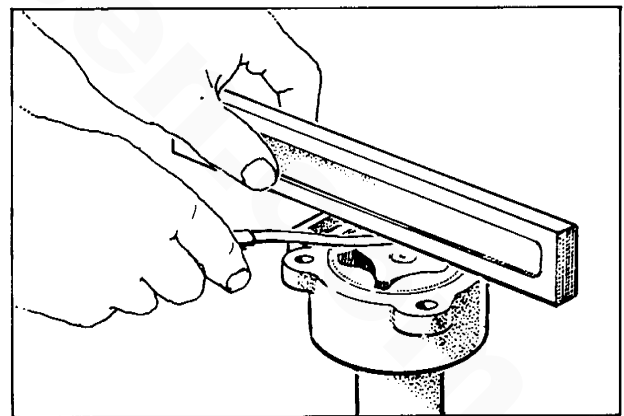

4. Then, place a straight edge across the pump cover and measure the clearance between the straight edge and cover. If the cover exceeds the limit, correct the pump cover by grinding or replace it.

Clearance limit: 0.15 mm (0.0059 in)

5. Check the clearance between the pump body and shaft using a dial indicator and magnetic base. If the clearance exceeds the limit, replace the pump drive shaft, inner rotor, pump body and drive gear.

Clearance limit:

0.1 mm (0.0039 in)

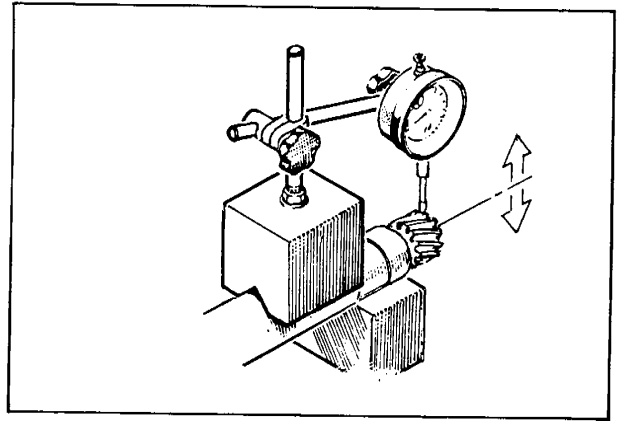

6. Check the relief valve for worn plunger and fatigued spring.

Spring free length:

40.0 mm (1.61 in)

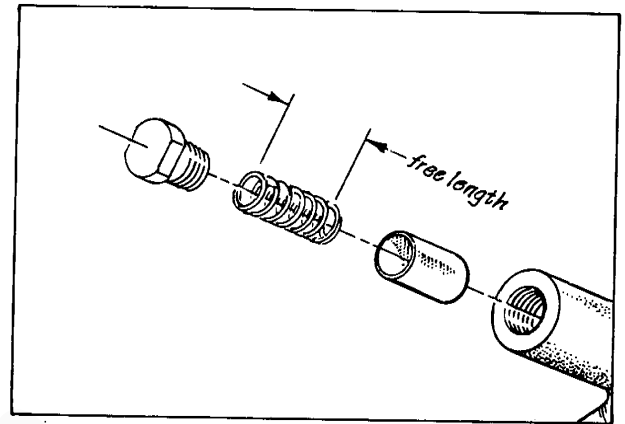

Assembling Oil Pump

Assemble in the reverse order of disassembling.

NOTE: When installing the rotors into the body, be sure that the tally marks on the rotors are positioned toward the cover.

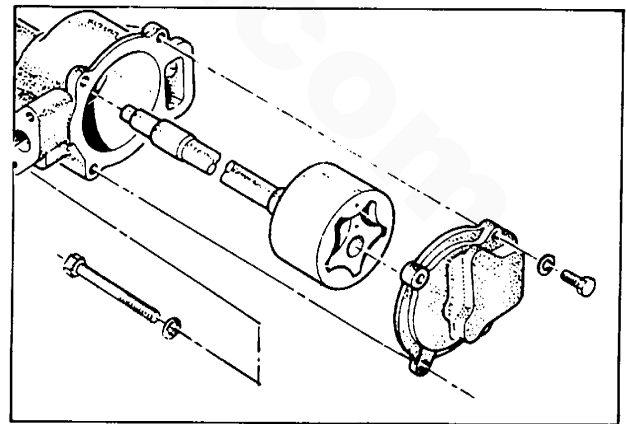
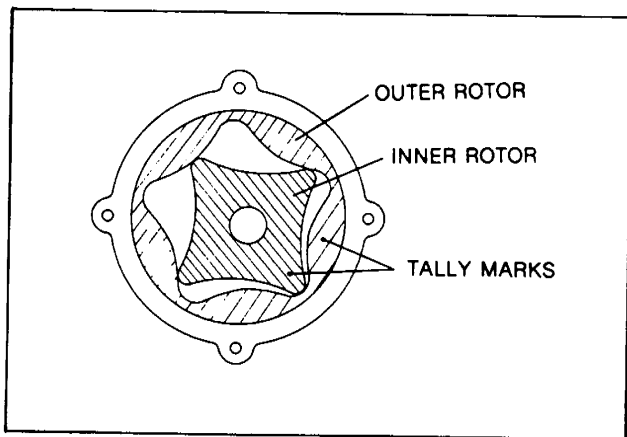

Cover tightening torque: 0.8 - 1.2 kg-m (5.8 - 8.7 lb-ft)

Installing Oil Pump

Install in the reverse order of removal.

Oil Pan

Before installing oil pan:

1. Scrape any dirt or metal particles from the inside of the oil pan.
2. Check the oil pan for cracks and damaged drain plug threads. Check for damage (uneven surface) at the bolt holes caused by overtorquing the bolts. Straighten surfaces as required. Repair any damage or replace the oil pan if repairs cannot be made satisfactorily.

Oil Cooler

Removal:

1. Drain the cooling water.
2. Remove the oil filter body (W70) and oil cooler cover (W100) from the cylinder block.
3. Remove the gasket.
4. Remove the oil cooler from the oil cooler cover and oil filter body (W70).

Installation:

Install in the reverse order of removal.

NOTE: After installing the oil cooler, start the engine and check for oil and water leaks. Replace the o-ring and gasket with new ones.

Checking:

Check the oil cooler core for clogs, cracks and any damage. If necessary, correct or replace them.

Oil Filter

Removal:

Remove the oil filter with a suitable wrench.

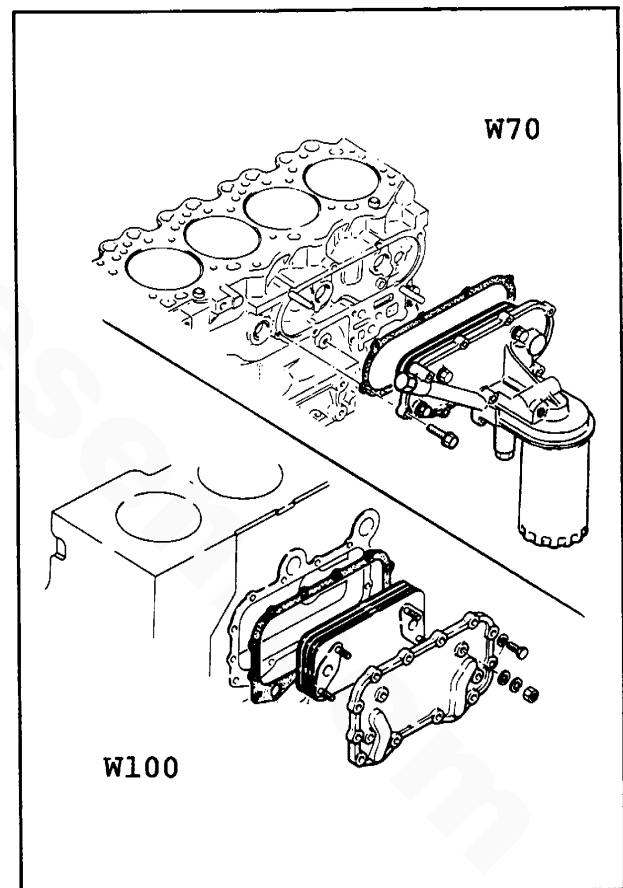

Installation:

1. Apply engine oil on the oil filter o-ring.
2. Fully tighten the oil filter by hand.
3. Supply the specified amount of engine oil.
4. While operating the engine, make sure that oil is not leaking from the filter installed section.

NOTE: Do not use a tool to tighten.

Oil Jet (W70)

Remove in the following order:

1. Oil pan
2. Oil pan upper block
3. Oil jet valve
Oil jet

Checking:

1. Make sure that the oil passage is not clogged.
2. Check and ensure that the spring incorporated in the oil jet valve is not stuck or damaged.

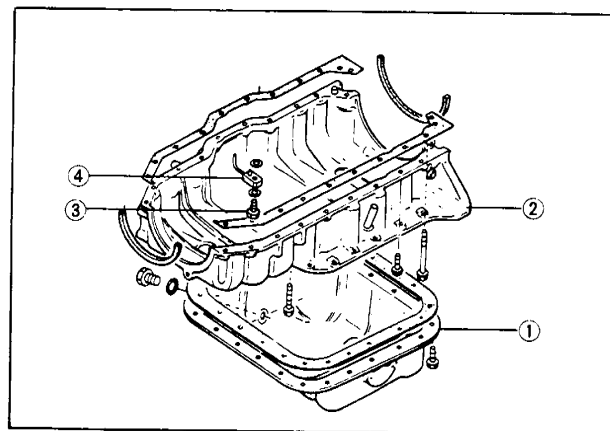

Installation:

Install in the reverse order of removal.

FRESH WATER CIRCULATING PUMP

Removing Fresh Water Pump

Remove in the following order:

1. Coolant (drain as needed)
2. "V" belt
3. Water hoses
4. Water pump attaching nuts
5. Water pump

Disassembling Water Pump

Disassemble in the following order:

1. Pulley boss, using a support and press.
2. Snap ring.
3. Impeller, shaft, bearings and spacer assembly.
Use a support block and a suitable mandrel.
4. Water seal. Use a suitable mandrel.
5. Snap ring.
6. Bearings and spacer. Use a suitable mandrel.

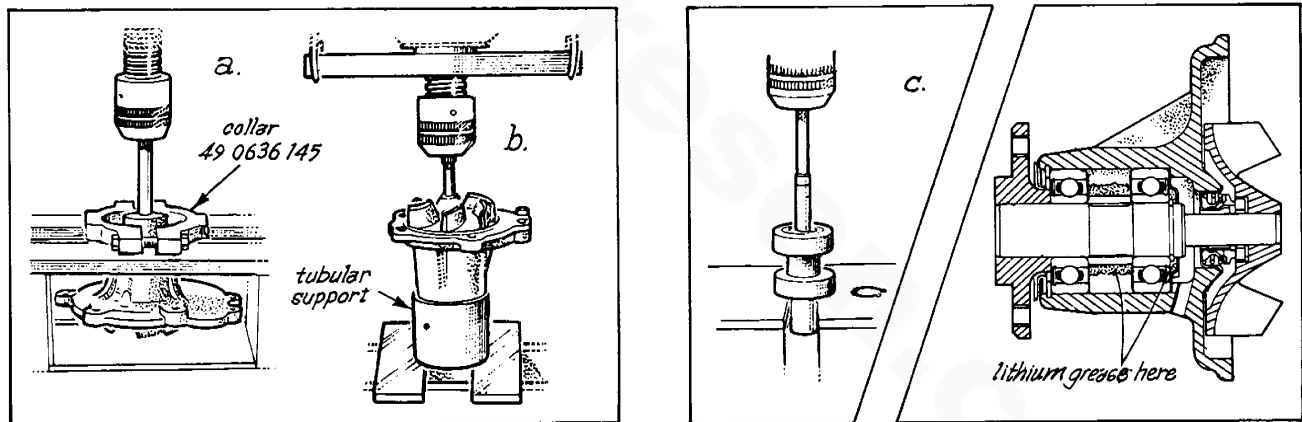

Checking Water Pump

1. Check the bearings for roughness or excessive end play.
2. Check the water pump body and impeller for cracks and damage.

Assembling Water Pump

Assemble in the following order:

1. Snap ring
2. Bearings and spacer

NOTE: Install the bearings so that the sealed sides face outward. Make sure that the front side of the bearing touches the snap

ring.

After installing the bearings and spacer, make sure that the bearings rotate smoothly.

3. Dust seal plate and baffle plate.
4. Shaft assembly. Use the Support Block and a suitable pipe.

NOTE: Fill one-third of the space between the two bearings with lithium grease.

After press fitting the shaft assembly, make sure that the shaft rotates smoothly.

5. Snap ring
6. Water seal

NOTE: Use a new water seal.

7. Pulley boss

NOTE: Press the pulley boss onto the shaft until it is flush with the front end of the shaft.

8. Impeller

NOTE: Apply a slight amount of engine oil on the contact surface between the water seal and impeller.

Press the impeller onto the shaft until it is flush with the rear end of the shaft.

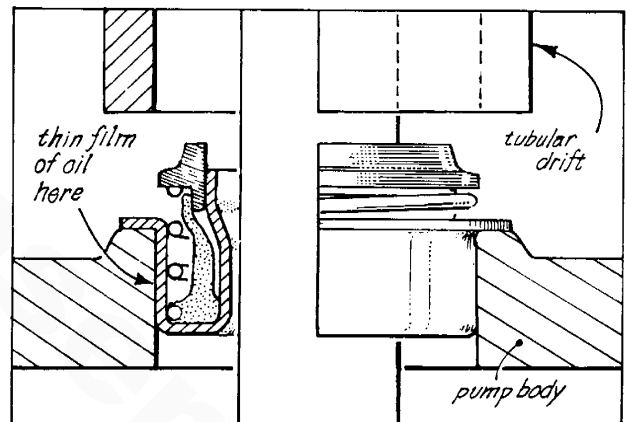

DO NOT ALLOW OIL OR GREASE TO CONTAMINATE THE SURFACES OF THE CERAMIC RING OR THE GRAPHITE (SMALL END) OF THE SPRING-LOADED SEAL.

Installing Water Pump

Install in the reverse order of removal.

NOTE: Use a new gasket.

After installing the water pump, fill the system with coolant and operate the engine to check for leaks. Adjust the "V" belt.

Excessive amount of tension on the alternator "V" belt is frowned on. This can result in shortening belt life and that of the fresh water circulating pump.

www.torresen.com

FUEL SYSTEM

Points

The injection pump is Diesel Kiki's Bosch-VE-distributor type which is compact, light and of simple design that provides high performance.

By turning off the engine switch key, the supply of fuel into the combustion chamber is cut off to stop engine dieseling.

When the engine is run in reverse, the fuel injection pressure does not develop and therefore the fuel is not injected. The engine never runs in reverse.

In addition to an engine mounted fuel filter, a sedimentor may be installed to help in the removal of water contained in the fuel. These filters should be monitored and serviced regularly.

Operation

The fuel in the fuel tank is introduced into the fuel lines by the injection pump's integral feed pump. Any water in the fuel is extracted by the sedimentor when installed. The fuel is then filtered by the fuel filter before it reaches the injection pump. The fuel supplied to the injection pump is sent into the plunger by the control sleeve, linked with the throttle lever, in an amount proportionate to the degree of lever depression. (The pressure of the fuel in the injection pump will be controlled in accordance with the engine RPM by the operation of the feed pump and the regulating valve built in the pump.)

The fuel sent to the plunger is highly pressurized and is forced through the delivery valve, injection line, injection nozzle, and is injected into each cylinder in the proper injection order.

Any fuel leaking at the sliding section of the nozzle's valve at the time of injection and any surplus fuel in the injection pump housing will be returned to the fuel tank through the overflow pipe. (The surplus fuel will circulate in the injection pump to lubricate and cool the pump.)

The fuel cut solenoid interrupts the fuel flow on the distributor side of the injection pump which closes the intake port of the plunger.

NOTE: Water in the fuel system reaching the injection pump and injectors is highly detrimental to their operation.

INJECTION PUMP

Should the injection pump require servicing, it should be removed and brought to a qualified injection pump servicing facility. Disassembly and repairs in the field should not be attempted.

Checking and Adjusting Injection Pump

1. Checking Idle Speed

- (a) Warm up the engine.
- (b) With the aid of the tachometer in the instrument panel, observe engine RPM.

NOTE: Should the panel tachometer be in question, verify its readings with the use of a photoelectric or hand-held tachometer taking readings off the front crankshaft pulley.

- (c) Adjust the idle speed as needed.

Idle Speed: 580 - 630 RPM

NOTE: This speed may vary depending on transmission and propeller.

2. Adjusting Idle Speed

- (a) With the engine at rest, inspect the throttle cable for proper travel. Insure it will move the throttle lever on the injection pump from the stop on the idle screw to the stop on the high speed screw. Adjust the throttle cable as needed to insure these stops are contacted.
- (b) Loosen the lock nut of the idle adjusting screw and adjust by turning the idle adjusting screw.

NOTE: Idle speed will increase when the adjusting screw is turned to the right and decrease when turned to the left.

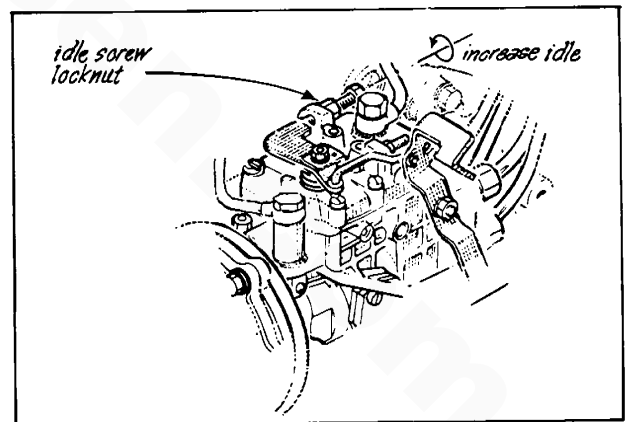

- (c) After the adjustment, race the engine two or three times and recheck the idle speed.

3. Engine Stopping Solenoid Troubleshooting

NOTE: This solenoid is installed on the top rear of the injection pump and is activated by 12 VDC electrical current. In the case of a generator set, refer also to the Generator Control Section of this book.

- (a) The solenoid does not operate when the keyswitch is turned "ON".
 - (1) Are the engine batteries turned "ON"?
 - (2) Is the 20 amp circuit breaker set?
 - (3) Is 12 VDC present at the solenoid connection?

- (b) The solenoid does not stop the engine when the keyswitch is shut "OFF".
 - (1) Check to see if 12 VDC is still present at the solenoid electrical lead with the key off.
 - (2) Remove solenoid from injection pump and insure plunger and spring in the solenoid are not sticking.

FUEL INJECTORS

Removing Injectors

Remove in the following order:

W70:

1. Fuel injection lines
2. Fuel return line attaching nuts and sealing washers
3. Fuel return line
4. Injectors
5. Copper sealing washers

W100:

1. Fuel return line
2. Fuel injection lines
3. Injectors
4. Gasket and dust seal

NOTE: Clean the area around the base of the injector prior to lifting it out of the cylinder head to help prevent any rust or debris from falling down into the injector hole. If the injector will not lift out easily and is held in by carbon build up or the like, work the injector side to side with the aid of an adjustable or open end wrench to free it and then lift it out.

Testing Injection Nozzle

NOTE: Test the nozzles using diesel fuel at approximate temperature at 20° C (68°F).

1. Checking Injection Starting Pressure

- (a) Install the nozzle on a nozzle tester and operate the hand lever a few times to remove air.

CAUTION: When using nozzle tester, the spray injected from the nozzle is of such velocity that it may penetrate deeply into the skin of fingers and hands, destroying tissue. If it enters the bloodstream, it may cause blood poisoning.

- (b) Operate the hand lever at 60 strokes/minute and check the injection starting pressure.

Injection starting pressure:

135 kg/cm² (1,920 lb/in²)

- (c) If the fuel injection starting pressure is not within the specification, adjust it.

NOTE:

W70: Adjust the starting pressure by replacing or adding shims. There are 27 shims available in increments of 0.04 mm from 0.5 mm to 1.45 mm. An increment of 0.04 mm causes the starting pressure to rise by approximately 4.8 kg/cm² (68.26 lb/in²).

W100: Loosen the cap nut on the injector body and adjust by turning the pressure adjusting screw with a screwdriver.

- (1) Increase the starting pressure to about 200 kg/cm² (2844 lb/in²) once.
- (2) Gradually lower the starting pressure to the specified value.
- (3) When the pressure is properly adjusted, keep the adjusting screw stationary with a screwdriver passed through the cap nut bolt hole and tighten the cap nut to 4-5 kg/m (9-11 lb/ft).
- (4) Check the injection starting pressure again.

2. Check Fuel Injection

Operate the hand lever quickly and verify that fuel is injected correctly from the nozzle orifice in the direction of the nozzle axis.

A nozzle is defective if it injects fuel in an oblique direction or in several separate strips. Also, a spray in the form of particles indicates a defect. These defects may sometimes be caused by clogging with dust and, therefore, all parts should be carefully cleaned before reassembly.

Also inspect the nozzle tip after several injections. If it drips or has a large accumulation of fuel on the bottom, it is considered defective and should be repaired or replaced. A very small amount of fuel may sometimes remain on the tip of the nozzle; however, this does not indicate a defect.

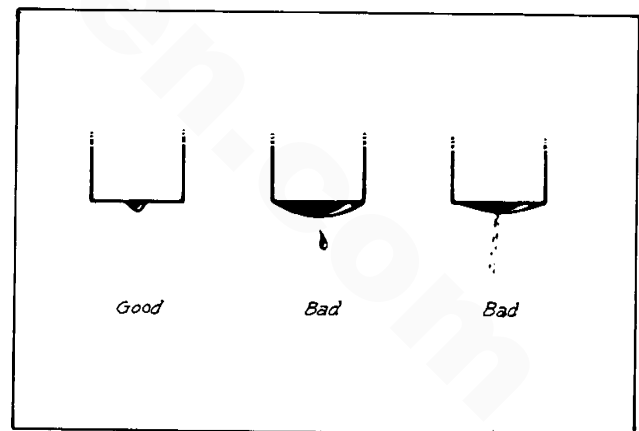
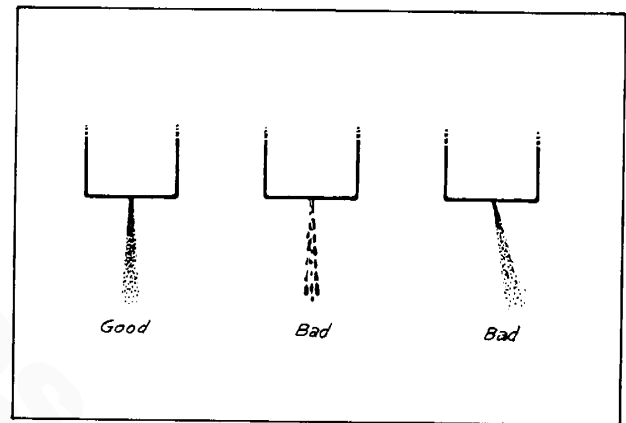

3. Checking Oil Tightness of Needle Valve Set

Operate the hand lever to raise the pressure up to 115 kg/cm² (1635 lb/in²), which is 20 kg/cm² (280 lb/in²) lower than the injection starting pressure. If fuel does not drip from the nozzle orifice under the pressure, oil tightness is satisfactory. Dripping of fuel, on the other hand, is indicative of damage on

the needle valve or the valve body, or poor contact between both. In that event, both needle valve and valve body must be replaced.

Disassembling Injector

Disassemble in the following order:

W70:

1. Nozzle body
2. Adjusting seat
3. Spring
4. Magnetic filter
5. Spacer
6. Nozzle
7. Nozzle holder

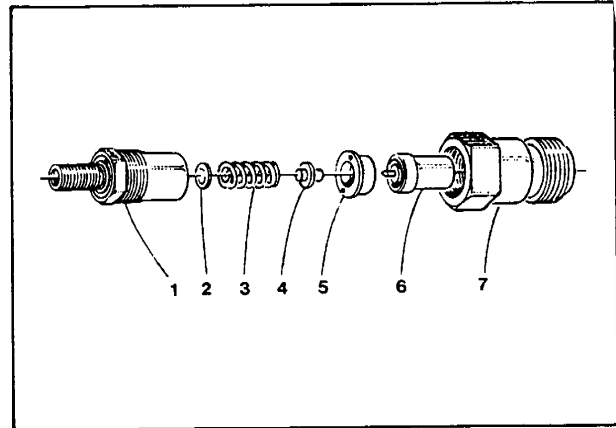

W100:

1. Cap nut (Ref. 3)
2. Gasket
3. Pressure adjusting screw
4. Adjusting seat
5. Spring
6. Pushrod
7. Connector and washer
8. Nozzle nut
9. Nozzle

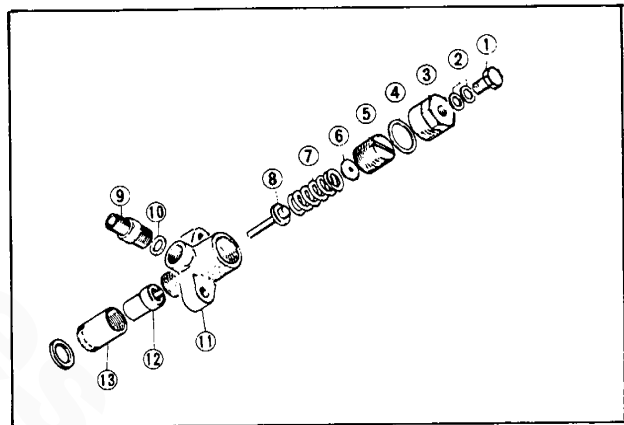

NOTE: Greatest possible care should be taken in handling the nozzles as they are very precisely machined. The nozzle and the needle valve are matched pairs. Do not mix their original combinations. Disassemble and wash each nozzle assembly separately.

Carbon deposits on the nozzle body must be removed with a piece of hard wood. However, it would be advisable not to clean the surrounding area of the nozzle orifice to avoid possible damage to the orifice.

Iron dust on the magnetic filter top must be removed completely.

Checking Injector Nozzle

Assure that the needle valve comes down into the valve seat by its weight when it is pushed in the nozzle body about 18 mm (0.708 in).

If it does not, replace the assembly.

If any defect is found, always replace the needle valve and the nozzle body as a unit.

Assembling Injector

Assemble in the reverse order of disassembling.

NOTE: After assembling the injector, test it.

W70: Tighten the nozzle body on the nozzle holder to the specified torque.

Nozzle body tightening torque (24 mm socket):

8.0 - 10.0 kg-m (58 - 72 lb-ft)

W100: Tighten the nozzle and cap nut to the specified torque.

Nozzle nut torque: 6.0 - 10.0 kg-m (43 - 72 lb-ft)

Cap nut torque: 4.0 - 5.0 Kg-m (29 - 36 lb-ft)

Installing Injector

Install in the reverse order of removal.

NOTE: The copper washers should not be reused. Replace with new washers.

W70: Tighten the nozzle on the cylinder head to the specified torque.

Nozzle tightening torque (27 mm socket):

6.0 - 7.0 kg-m (43 - 51 lb-ft)

W100 injector holder tightening torque:

1.6 - 2.4 kg-m (12 - 17 lb-ft)

FUEL SYSTEM TROUBLESHOOTING

<u>SYMPTOM</u>	<u>PROBABLE CAUSE</u>	<u>REPAIR</u>
1. Engine hard to start or fails to start.	a) No fuel at injectors.	Check causes b) thru f).
	b) Fuel in fuel tank and/or fuel shut off.	Fill tank. Open shut off and bleed system.
	c) Fuel filter clogged.	Replace filter and bleed.
	d) Air in injection pump.	Bleed pump. Check fittings for suction leak on fuel supply.
	e) Fuel shut off solenoid not working.	Troubleshoot as described in previous section.
	f) Injection pump faulty.	Inspect pump and repair or replace as needed.
	g) Fuel injectors faulty.	Remove and test nozzles and repair as needed.
	h) Water and/or air in fuel filters.	Remove water and/or bleed air. Check system for leaks and fuel tank for water contamination.
	i) Injection timing incorrect.	Check and adjust timing.
	j) Glow plugs not operating.	Check glow plug circuit and repair as needed.
	2. Engine idling too low.	a) Idle speed too low.
b) Fuel filter clogged.		Replace filter and bleed.
c) Incorrect injection pump timing.		Check timing and adjust as needed.
d) High pressure injector line leaking.		Slacken attaching nut and retighten.
e) Fuel injector leaking at sealing gasket in head.		Retighten injector and/or replace sealing washer.
f) Injection nozzle not operating properly.		Check nozzle and adjust as needed.

- | | | |
|---|--|--|
| | g) Engine air intake obstructed. | Check air intake silencer and air flow into engine compartment. |
| 3. Fuel consumption too high. | a) Idle speed too high. | Check engine speed. |
| | b) Engine air intake restricted. | Check intake and correct. |
| | c) Injection timing incorrect. | Check timing and readjust pump. |
| | d) Injector nozzle leaking. | Tighten nozzle or replace sealing gasket. |
| | e) Injector not operating properly. | Remove injector and adjust nozzle spray pressure. |
| | f) Engine overloaded. | Check propeller size and engine performance at rated RPM. |
| 4. Engine output and performance poor. | a) Contaminated or inferior fuel. | Purge fuel system and replace with quality fuel. |
| | b) Fuel filter obstructed. | Remove and replace filter element. |
| | c) Air in fuel system. | Bleed and check for source. |
| | d) Injection pump timing incorrect. | Check timing and adjust pump as needed. |
| | e) Injector high pressure lines leaking. | Loosen and then retighten injector line attachment nut or replace the complete line. |
| | f) Injectors not operating properly. | Remove injectors and adjust spray pressure to proper setting. |
| | g) Shaft stuffing box nut too tight. | Check shaft free movement and for heat. Adjust gland nut as needed. |
| | h) Valves improperly adjusted. | Check valve adjustment and maintain. |
| 5. Large amount of black exhaust smoke. | a) Clogged fuel filter. | Replace fuel filter and bleed. |

- | | | |
|--------------------------------|---|--|
| | b) Restricted air intake. | Remove air obstruction. |
| | c) Engine overloaded. | Check engine propeller size and engine performance no load - fully loaded. |
| | d) Injection timing. | Check injection pump timing and adjust as needed. |
| | e) Fuel injectors not operating properly. | Check nozzle spray pressure. |
| 6. Abnormal noise from engine. | a) Poor quality and/or incorrect fuel. | Use No. 2 diesel fuel. |
| | b) Incorrect injection timing. Timing too advanced. | Check injection timing. |
| | c) Fuel injector stuck open. | Locate injector and remove, replace or rebuild. |

W70 ENGINE SPECIFICATIONS

Type	Four cylinder four stroke engine in line, water cooled, overhead valve
Bore	95.0 mm (3.74 in)
Stroke	105.0 mm (4.13 in)
Piston displacement	2977 cc (181.7 cu in)
Compression ratio	21:1
Compression pressure (at 200 rpm)	
Standard	30.0 kg/cm ² (427 lb/in ²)
Limit	27.0 kg/cm ² (384 lb/in ²)
Limit of difference between cylinders	3.0 kg/cm ² (42.7 lb/in ²)
Valve clearance (Cold Engine)	
Intake	0.30 mm (0.012 in)
Exhaust	0.30 mm (0.012 in)
Cylinder head	
Permissible distortion of cylinder head surface	0.10 mm (0.004 in)
Valve timing	
Intake valve opens	17° BTDC
Intake valve closes	47° ABDC
Exhaust valve opens	51° BBDC
Exhaust valve closes	13° ATDC
Valve seat	
Valve seat angle	
Intake	45°
Exhaust	30°
Valve seat width	
Intake	2.0 mm (0.079 in)
Exhaust	2.0 mm (0.079 in)
Dimension "L" (Valve sinking)	
Standard	48.05 mm (1.892 in)
Limit	49.55 mm (1.949 in)
Valve guide	
Protrusion from cylinder head	16.5 mm (0.65 in)
Stem to guide clearance	
Standard intake	0.038 - 0.085 mm (0.0015 - 0.0033 in)
Standard exhaust	0.058 - 0.105 mm (0.0023 - 0.0041 in)
Limit	0.127 mm (0.0050 in)
Guide inner diameter	9.018 - 9.040 mm (0.355 - 0.356 in)
Valve-Intake	
Head diameter	40.4 - 40.6 mm (1.59 - 1.60 in)
Head thickness	
Standard	1.5 mm (0.059 in)
Limit	1.0 mm (0.039 in)
Face angle	45°
Stem diameter	
Standard	8.955 - 8.980 mm (0.353 - 0.354 in)
Limit	8.904 mm (0.351 in)

Valve-Exhaust	
Head diameter	37.40 - 37.60 mm (1.47 - 1.48 in)
Head thickness	
Standard	1.5 mm (0.059 in)
Limit	1.0 mm (0.039 in)
Face angle	30°
Stem diameter	
Standard	8.935 - 8.960 mm (0.352 - 0.353 in)
Limit	8.884 mm (0.350 in)
Valve spring-outer	
Free length	
Standard	55.7 mm (2.193 in)
Limit	52.9 mm (2.083 in)
Fitting length	40.3 mm (1.587in)
Fitting load	
Standard	32.4 - 34.2 kg (71.43 - 75.40 lb)
Limit	30.1 kg (66.36 lb)
Squareness limit	1.37 mm (0.054 in)
Spring constant	2.16 kg/mm (121 lb/in)
Valve spring-Inner	
Free length	
Standard	44.1 mm (1.736 in)
Limit	42.0 mm (1.654 in)
Fitting length	37.8 mm (1.488 in)
Fitting load	
Standard	12.1 - 13.3 kg (26.68 - 29.32 lb)
Limit	11.3 kg (24.92 lb)
Squareness limit	1.25 mm (0.049 in)
Spring constant	2.02 kg/mm (113 lb/in)
Rocker arm bore	15.876 - 15.896 mm (0.625 - 0.626 in)
Rocker arm shaft	
Outer diameter	15.835 - 15.860 mm (0.6234 - 0.6244 in)
Clearance in rocker arm	
Standard	0.016 - 0.061 mm (0.0006 - 0.0024 in)
Limit	0.07 mm (0.0028 in)
Tappet	
Outer diameter	14.224 - 14.249 mm (0.5600 - 0.5610 in)
Bore in cylinder block	14.288 - 14.319 mm (0.5630 - 0.5640 in)
Clearance in cylinder	
block bore	
Standard	0.039 - 0.095 mm (0.0015 - 0.0037 in)
Limit	0.10 mm (0.0039 in)
Camshaft	
Journal diameter	
No. 1 (Front)	51.910 - 51.940 mm (2.0437 - 2.0449 in)
No. 2	51.660 - 51.690 mm (2.0339 - 2.0351 in)
No. 3	51.410 - 51.440 mm (2.0240 - 2.0250 in)
No. 4 (Rear)	51.160 - 51.190 mm (2.0142 - 2.0154 in)
Wear Limit of journal	0.008 mm (0.0003 in)
Cam elevation	
Intake	
Standard	42.580 mm (1.676 in)
Limit	42.478 mm (1.672 in)

Exhaust	
Standard	42.580 mm (1.676 in)
Limit	42.478 mm (1.672 in)
Camshaft end play	
Standard	0.020 - 0.180 mm (0.0008 - 0.0071 in)
Limit	0.30 mm (0.0118 in)
Camshaft run-out	
Limit	0.08 mm (0.0031 in)
Camshaft support bore	
Bore in cylinder	
block	
No. 1 (Front)	52.000 - 52.030 mm (2.0473 - 2.0485 in)
No. 2	51.750 - 51.780 mm (2.0374 - 2.0386 in)
No. 3	51.500 - 51.530 mm (2.0280 - 2.0290 in)
No. 4 (Rear)	51.250 - 51.280 mm (2.0177 - 2.0189 in)
Oil Clearance	
Standard	0.060 - 0.120 mm (0.0024 - 0.0047 in)
Limit	0.145 mm (0.0057 in)
Backlash between gears	
Standard	0.10 - 0.17 mm (0.0039 - 0.0067 in)
Limit	0.30 mm (0.0118 in)
Idler gear end play	0.15 - 0.28 mm (0.0059 - 0.0118 in)
Idler gear bushing	
Inner diameter	44.009 - 44.034 mm (1.7327 - 1.7336 in)
Idler gear spindle	
Outer diameter	43.950 - 43.975 mm (1.7303 - 1.7313 in)
Spindle and bushing	
Clearance	
Standard	0.034 - 0.084 mm (0.0013 - 0.0033 in)
Limit	0.15 mm (0.0059 in)
Connecting rod	
Permissible bend or twist	0.05 mm per 100 mm (0.0020 in per 4 in)
Side clearance	
Standard	0.239 - 0.340 mm (0.0094 - 0.0134 in)
Limit	0.40 mm (0.0157 in)
Small end bore	30.012 - 30.033 mm (1.1816 - 1.1824 in)
Piston pin and	
small end bushing	
clearance	
Standard	0.012 - 0.039 mm (0.0005 - 0.0015 in)
Limit	0.05 mm (0.0020 in)
Connecting rod bearing	
Bearing clearance	
Standard	0.036 - 0.076 mm (0.0014 - 0.0030 in)
Limit	0.10 mm (0.0039 in)
Available undersize	0.254 mm (0.01 in)
bearing	0.508 mm (0.02 in)
	0.762 mm (0.03 in)
Piston	
Diameter	94.967 - 94.993 mm (3.7381 - 3.7399 in)
Distance from bottom to	
take measurement	22.0 mm (0.866 in)
Piston pin hole bore	29.996 - 30.008 mm (1.1809 - 1.1814 in)

Ring groove width	
Top	2.433 - 2.453 mm (0.0958 - 0.0966 in)
Second	2.423 - 2.443 mm (0.0954 - 0.0962 in)
Oil	4.793 - 4.813 mm (0.1887 - 0.1895 in)
Piston and liner clearance	0.032 - 0.083 mm (0.0017 - 0.0028 in)
Piston ring Thickness	
Top	2.363 - 2.383 mm (0.0920 - 0.0938 in.)
Second	2.363 - 2.383 mm (0.0930 - 0.0938 in.)
Oil	4.743 - 4.763 mm (0.1867 - 0.1875 in.)
Side clearance	
Top	0.050 - 0.180 mm (0.0020 - 0.0070 in)
Second	0.040 - 0.080 mm (0.0016 - 0.0031 in)
Oil	0.030 - 0.070 mm (0.0012 - 0.0028 in)
Side clearance limit	0.30 mm (0.118 in)
End gap	
Top	0.40 - 0.60 mm (0.0157 - 0.0240 in)
Second	0.40 - 0.60 mm (0.0157 - 0.0240 in)
Oil	0.40 - 0.60 mm (0.0157 - 0.0240 in)
End gap limit	1.5 mm (0.0591 in)
Piston pin Diameter	29.994 - 30.000 mm (1.1809 - 1.1811 in)
Clearance between piston and pin	0 - 0.016 mm (0 - 0.0006 in)
Crankshaft Main journal diameter	
Standard	75.812 - 75.825 mm (2.9848 - 2.9853 in)
Wear limit	0.05 mm (0.0020 in)
Grinding limit	75.05 mm (2.955 in)
Crankpin diameter	
Standard	61.112 - 61.125 mm (2.4060 - 2.4065 in)
Wear limit	0.05 mm (0.0020 in)
Grinding limit	60.35 mm (2.376 in)
Crankshaft end play	
Standard	0.140 - 0.390 mm (0.0055 - 0.0154 in)
Limit	0.40 mm (0.0157 in)
Crankshaft run out	
Limit	0.05 mm (0.0020 in)
Main bearing Bearing clearance	
Standard	0.059 - 0.090 mm (0.0020 - 0.0037 in)
Limit	0.12 mm (0.0047 in)
Available undersize bearing	0.254 mm (0.010 in)
	0.508 mm (0.020 in)
	0.762 mm (0.030 in)
Cylinder block Distortion limit	0.10 mm (0.004 in)
Cylinder liner Inner diameter	
Standard	95.025 - 95.050 mm (3.7412 - 3.7422 in)
Wear limit	0.20 mm (0.0079 in)
Liner protrusion above cylinder block	-0.101 - 0.000 mm (-0.0040 - 0.0000 in)

Flywheel to crankshaft
Run-out limit (static) 0.20 mm (0.0079 in)

LUBRICATING SYSTEM

Oil pressure 3.8 kg/cm² (54 lb/in²)
and more at 3600 rpm

Safe minimum pressure at idle 0.3 ± 0.1 kg/cm²
(4.3 ± 1.4 lb/in²)

Oil capacity (sump) 6.0 liters
(6.3 U.S. quarts)
(5.3 Imp. quarts)

Lubricant
Classification A.P.I. Service CC.
Weight
27°C (80°F) or over SAE 30
-1 - 27°C (30 - 80°F) SAE 20W
-18 - -1°C (0 - 30°F) SAE 10W

Oil pump
Outer rotor and body clearance
Standard 0.14 - 0.25 mm (0.0055 - 0.0100 in)
Limit 0.30 mm (0.0118 in)

Clearance between rotor lobes
Standard 0.04 - 0.15 mm (0.0016 - 0.0059 in)
Limit 0.30 mm (0.0118 in)

Rotor end float
Standard 0.04 - 0.10 mm (0.0016 - 0.0039 in)
Limit 0.15 mm (0.0059 in)

Clearance between pump shaft and body
Standard 0.06 - 0.15 mm (0.0024 - 0.0079 in)
Limit 0.10 mm (0.0039 in)

FUEL SYSTEM

Idle speed 600 - 650 rpm

Fuel injection pump
Type Distributor type
Plunger diameter 10.0 mm (0.393 in)
Cam lift 2.2 mm (0.0866 in)
Governor Mechanical type
Injection timing 0° T.D.C.
Injection order 1 - 3 - 4 - 2

Injection nozzle
Type Throttle type
Nozzle diameter 0.8 mm (0.0315 in)
Injection pressure 135 +5/-0 kg/cm² (1920 + 71/-0 lb/in²)

Glow plug
Type Sheathed type
Pre-heating method Pre-combustion chamber pre-heating type

W70 TORQUE SPECIFICATIONS

	kg-m	lb-ft
Cylinder head	11.8 - 12.5	85 - 90
Cylinder head cover (rocker cover)	0.3 - 0.45	2 - 3
Connecting rod cap	8.2 - 9.0	59 - 65
Main bearing cap	11.0 - 11.7	80 - 85
Camshaft thrust plate	1.6 - 2.4	12 - 17
Camshaft gear	6.4 - 9.5	46 - 69
Idler gear	2.3 - 3.2	17 - 23
Injection pump drive gear	4.0 - 7.0	29 - 51
Rocker arm assembly	11.0 - 11.7	80 - 85
Timing gear case	1.6 - 2.4	12 - 17
Timing gear cover	1.6 - 2.4	12 - 17
Rear oil seal cap	1.5 - 2.0	11 - 15
Oil pan	1.6 - 2.3	12 - 17
Oil pump cover	0.8 - 1.2	6 - 9
Oil pump pipe	0.8 - 1.2	6 - 9
Fresh water pump	1.6 - 2.4	12 - 17
Crankshaft pulley	35.0 - 40.0	253 - 289
Glow plug	1.0 - 1.5	7 - 11
Injector to head	6.0 - 7.0	43 - 51
Injection nozzle to body	8.0 - 10.0	58 - 72
Injection pipe flare nut	2.5 - 3.0	18 - 22
Intake manifold	1.6 - 2.4	12 - 17
Exhaust manifold	1.6 - 2.4	12 - 17
Back plate	3.3 - 4.8	24 - 35
Flywheel	13.1 - 19.0	95 - 137
Damper	1.9 - 2.7	14 - 20

UNLESS OTHERWISE SPECIFIED

Grade 6T

6mm bolt/nut	0.7 - 1.0	5 - 7
8mm bolt/nut	1.6 - 2.3	12 - 17
10mm bolt/nut	3.2 - 4.7	23 - 34
12mm bolt/nut	5.6 - 8.2	41 - 59
14mm bolt/nut	7.7 - 10.5	56 - 76

Grade 8T and 8.8

6mm bolt/nut	.8 - 1.2	6 - 9
8mm bolt/nut	1.8 - 2.7	13 - 20
10mm bolt/nut	3.7 - 5.5	27 - 40
12mm bolt/nut	6.4 - 9.5	46 - 69
14mm bolt/nut	10.4 - 14.0	75 - 101

Grade 5 capscrew

1/4 UNC	1.2 - 1.5	9 - 11
1/4 UNF	1.5 - 1.8	11 - 13
5/16 UNC	2.5 - 2.8	18 - 20
5/16 UNF	2.9 - 3.2	21 - 23
3/8 UNC	3.7 - 4.6	28 - 33
3/8 UNF	4.1 - 4.8	30 - 35
7/16 UNC	6.1 - 6.8	44 - 49
7/16 UNF	6.9 - 7.6	50 - 55
1/2 UNC	9.4 - 10.1	68 - 73
1/2 UNF	10.1 - 11.1	73 - 80

W100 ENGINE SPECIFICATIONS

Type	Six cylinder four stroke engine in line, water cooled, overhead valve
Bore	92.0 mm (3.62 in)
Stroke	101.6 mm (4.00 in)
Piston displacement	4052 cc (247.3 cu-in)
Compression ratio	21:1
Compression pressure (at 200 rpm)	
Standard	30.0 kg/cm ² (427 lb/in ²)
Limit	27.0 kg/cm ² (384 lb/in ²)
Limit of difference between cylinders	3.0 kg/cm ² (42.7 lb/in ²)
Valve clearance (Cold Engine)	
Intake	0.30 mm (0.012 in)
Exhaust	0.30 mm (0.012 in)
Cylinder head	
Permissible distortion of cylinder head surface	0.10 mm (0.004 in)
Valve timing	
Intake valve opens	14° BTDC
Intake valve closes	44° ABDC
Exhaust valve opens	48° BBDC
Exhaust valve closes	10° ATDC
Valve seat	
Valve seat angle	
Intake	45°
Exhaust	30°
Valve seat width	
Intake	2.0 mm (0.079 in)
Exhaust	2.0 mm (0.079 in)
Dimension "L" (Valve sinking)	
Standard	48.04 mm (1.891 in)
Limit	49.54 mm (1.950 in)
Valve guide	
Protrusion from cylinder head	16.5 mm (0.65 in)
Stem to guide clearance	
Standard intake	0.038 - 0.089 mm (0.0015 - 0.0035 in)
Standard exhaust	0.051 - 0.102 mm (0.0020 - 0.0040 in)
Limit	0.127 mm (0.0050 in)
Guide inner diameter	7.988 - 8.014 mm (0.315 - 0.316 in)
Valve-Intake	
Head diameter	40.4 - 40.6 mm (1.59 - 1.60 in)
Head thickness	
Standard	1.7 mm (0.067 in)
Limit	1.0 mm (0.039 in)
Face angle	45°
Stem diameter	
Standard	7.925 - 7.950 mm (0.312 - 0.313 in)
Limit	7.867 mm (0.310 in)
Valve-Exhaust	

Head diameter	35.87 - 36.13 mm (1.41 - 1.42 in)
Head thickness	
Standard	1.5 mm (0.059 in)
Limit	1.0 mm (0.039 in)
Face angle	30°
Stem diameter	
Standard	7.912 - 7.937 mm (0.311 - 0.312 in)
Limit	7.854 mm (0.309 in)
Valve spring-outer	
Free length	
Standard	45.9 mm (1.807 in)
Limit	43.6 mm (1.717 in)
Fitting length	40.3 mm (1.587 in)
Fitting load	
Standard	32.4 - 34.2 kg (71.43 - 75.40 lb)
Limit	30.1 kg (66.36 lb)
Squareness limit	1.37 mm (0.054 in)
Spring constant	3.20 kg/mm (179 lb/in)
Valve spring-Inner	
Free length	
Standard	44.1 mm (1.736 in)
Limit	42.0 mm (1.654 in)
Fitting length	37.8 mm (1.488 in)
Fitting load	
Standard	12.1 - 13.3 kg (26.68 - 29.32 lb)
Limit	11.3 kg (24.92 lb)
Squareness limit	1.25 mm (0.049 in)
Spring constant	2.02 kg/mm (113 lb/in)
Rocker arm bore	15.876 - 15.896 mm (0.625 - 0.626 in)
Rocker arm shaft	
Outer diameter	15.835 - 15.860 mm (0.6234 - 0.6244 in)
Clearance in rocker arm	
Standard	0.016 - 0.061 mm (0.0006 - 0.0024 in)
Limit	0.07 mm (0.0028 in)
Tappet	
Outer diameter	14.224 - 14.249 mm (0.5600 - 0.5610 in)
Bore in cylinder block	14.288 - 14.319 mm (0.5630 - 0.5640 in)
Clearance in cylinder	
block bore	
Standard	0.039 - 0.095 mm (0.0015 - 0.0037 in)
Limit	0.10 mm (0.0039 in)
Camshaft	
Journal diameter	
No. 1 (Front)	51.910 - 51.940 mm (2.0437 - 2.0449 in)
No. 2	51.660 - 51.690 mm (2.0339 - 2.0351 in)
No. 3	51.410 - 51.440 mm (2.0240 - 2.0250 in)
No. 4 (Rear)	51.160 - 51.190 mm (2.0142 - 2.0154 in)
Wear Limit of	
journal	0.008 mm (0.0003 in)
Cam elevation	
Intake	
Standard	42.587 mm (1.677 in)
Limit	42.585 mm (1.677 in)

Exhaust	
Standard	42.587 mm (1.677 in)
Limit	42.485 mm (1.673 in)
Camshaft end play	
Standard	0.020 - 0.180 mm (0.0008 - 0.0071 in)
Limit	0.30 mm (0.0118 in)
Camshaft run-out	
Limit	0.08 mm (0.0031 in)
Camshaft support bore	
Bore in cylinder block	
No. 1 (Front)	52.000 - 52.030 mm (2.0473 - 2.0485 in)
No. 2	51.750 - 51.780 mm (2.0374 - 2.0386 in)
No. 3	51.500 - 51.530 mm (2.0280 - 2.0290 in)
No. 4 (Rear)	51.250 - 51.280 mm (2.0177 - 2.0189 in)
Oil Clearance	
Standard	0.060 - 0.120 mm (0.0024 - 0.0047 in)
Limit	0.145 mm (0.0057 in)
Backlash between gears	
Standard	0.10 - 0.20 mm (0.0039 - 0.0079 in)
Limit	0.30 mm (0.0118 in)
Idler gear end play	0.15 - 0.28 mm (0.0059 - 0.0118 in)
Idler gear bushing	
Inner diameter	44.009 - 44.034 mm (1.7327 - 1.7336 in)
Idler gear spindle	
Outer diameter	43.950 - 43.975 mm (1.7303 - 1.7313 in)
Spindle and bushing clearance	
Standard	0.034 - 0.084 mm (0.0013 - 0.0033 in)
Limit	0.15 mm (0.0059 in)
Connecting rod	
Permissible bend or twist	0.05 mm per 100 mm (0.0020 in per 4 in)
Side clearance	
Standard	0.239 - 0.340 mm (0.0094 - 0.0134 in)
Limit	0.40 mm (0.0157 in)
Small end bore	31.763 - 31.788 mm (1.2505 - 1.2515 in)
Piston pin and small end bushing clearance	
Standard	0.014 - 0.044 mm (0.0006 - 0.0017 in)
Limit	0.05 mm (0.0020 in)
Connecting rod bearing	
Bearing clearance	
Standard	0.036 - 0.076 mm (0.0014 - 0.0030 in)
Limit	0.10 mm (0.0039 in)
Available undersize bearing	0.254 mm (0.01 in)
	0.508 mm (0.02 in)
	0.762 mm (0.03 in)
Piston	
Diameter	91.967 - 91.993 mm (3.6207 - 3.6218 in)
Distance from bottom to take measurement	23.0 mm (0.9055 in)
Piston pin hole bore	31.745 - 31.757 mm (1.2498 - 1.2503 in)

Ring groove width	
Top	2.433 - 2.453 mm (0.0958 - 0.0966 in)
Second	2.423 - 2.443 mm (0.0954 - 0.0962 in)
Oil	4.793 - 4.813 mm (0.1887 - 0.1895 in)
Piston and liner clearance	0.032 - 0.083 mm (0.0017 - 0.0028 in)
Piston ring	
Thickness	
Top	2.363 - 2.383 mm (0.0920 - 0.0938 in.)
Second	2.363 - 2.383 mm (0.0930 - 0.0938 in.)
Oil	4.743 - 4.763 mm (0.1867 - 0.1875 in.)
Side clearance	
Top	0.050 - 0.180 mm (0.0020 - 0.0070 in)
Second	0.040 - 0.080 mm (0.0016 - 0.0031 in)
Oil	0.030 - 0.070 mm (0.0012 - 0.0028 in)
Side clearance limit	0.30 mm (0.118 in)
End gap	
Top	0.35 - 0.55 mm (0.0138 - 0.0217 in)
Second	0.35 - 0.55 mm (0.0138 - 0.0217 in)
Oil	0.35 - 0.55 mm (0.0138 - 0.0217 in)
End gap limit	1.5 mm (0.0591 in)
Piston pin	
Diameter	31.744 - 31.749 mm (1.2498 - 1.2500 in)
Clearance between piston and pin	0 - 0.016 mm (0 - 0.0006 in)
Crankshaft	
Main journal diameter	
Standard	69.812 - 69.825 mm (2.7485 - 2.7491 in)
Wear limit	0.05 mm (0.0020 in)
Grinding limit	69.05 mm (2.718 in)
Crankpin diameter	
Standard	57.112 - 57.125 mm (2.2485 - 2.2491 in)
Wear limit	0.05 mm (0.0020 in)
Grinding limit	56.35 mm (2.218 in)
Crankshaft end play	
Standard	0.140 - 0.390 mm (0.0055 - 0.0154 in)
Limit	0.40 mm (0.0157 in)
Crankshaft run out	
Limit	0.05 mm (0.0020 in)
Main bearing	
Bearing clearance	
Standard	0.059 - 0.090 mm (0.0020 - 0.0037 in)
Limit	0.12 mm (0.0047 in)
Available undersize bearing	
0.254 mm (0.010 in)	
0.508 mm (0.020 in)	
0.762 mm (0.030 in)	
Cylinder block	
Distortion limit	0.10 mm (0.004 in)
Cylinder liner	
Inner diameter	
Standard	92.025 - 92.050 mm (3.6231 - 3.6241 in)
Wear limit	0.20 mm (0.0079 in)
Liner protrusion above cylinder block	-0.101 - 0.000 mm (-0.0040 - 0.0000 in)

Flywheel to crankshaft
Run-out limit (static) 0.20 mm (0.0079 in)

LUBRICATING SYSTEM

Oil pressure 3.8 kg/cm² (54 lb/in²)
and more at 3600 rpm

Safe minimum pressure at idle 0.3 ± 0.1 kg/cm²
(4.3 ± 1.4 lb/in²)

Oil capacity (sump) 11.3 liters
(11.9 U.S. quarts)
(9.9 Imp. quarts)

Lubricant
Classification A.P.I. Service CC.
Weight
27°C (80°F) or over SAE 30
-1 - 27°C (30 - 80°F) SAE 20W
-18 - -1°C (0 - 30°F) SAE 10W

Oil pump
Outer rotor and body clearance
Standard 0.14 - 0.25 mm (0.0055 - 0.0100 in)
Limit 0.30 mm (0.0118 in)
Clearance between rotor lobes
Standard 0.04 - 0.20 mm (0.0016 - 0.0079 in)
Limit 0.30 mm (0.0118 in)
Rotor end float
Standard 0.04 - 0.10 mm (0.0016 - 0.0039 in)
Limit 0.15 mm (0.0059 in)
Clearance between pump shaft and body
Standard 0.06 - 0.15 mm (0.0024 - 0.0079 in)
Limit 0.10 mm (0.0039 in)

FUEL SYSTEM

Idle speed 550 - 600 rpm

Fuel injection pump
Type Distributor type
Plunger diameter 11.0 mm (0.433 in)
Cam lift 2.0 mm (0.0787 in)
Governor Mechanical type
Injection timing 0° T.D.C.
Injection order 1 - 5 - 3 - 6 - 2 - 4

Injection nozzle
Type Throttle type
Nozzle diameter 0.8 mm (0.0315 in)
Injection pressure 135 +5/-0 kg/cm² (1920 + 71/-0 lb/in²)

Glow plug
Type Sheathed type
Pre-heating method Pre-combustion chamber pre-heating type

W100 TORQUE SPECIFICATIONS

	kg-m	lb-ft
Cylinder head	11.0 - 11.7	80 - 85
Cylinder head cover (rocker cover)	0.3 - 0.45	2 - 3
Connecting rod cap	7.6 - 8.3	55 - 60
Main bearing cap	11.0 - 11.7	80 - 85
Camshaft thrust plate	1.6 - 2.4	12 - 17
Camshaft gear	6.2 - 7.0	45 - 51
Idler gear	2.3 - 3.2	17 - 23
Injection pump drive gear	4.0 - 7.0	29 - 51
Rocker arm assembly	11.0 - 11.7	80 - 85
Timing gear case	1.6 - 2.4	12 - 17
Timing gear cover	1.6 - 2.4	12 - 17
Rear oil seal cap	1.5 - 2.0	11 - 15
Oil pan	1.6 - 2.3	12 - 17
Oil pump cover	0.8 - 1.2	6 - 9
Oil pump pipe	0.8 - 1.2	6 - 9
Fresh water pump	1.6 - 2.4	12 - 17
Crankshaft pulley	39.0 - 42.0	282 - 304
Glow plug	1.0 - 1.5	7 - 11
Injector to head	1.6 - 2.4	12 - 17
Injector cap nut	4.0 - 5.0	29 - 36
Injection nozzle to body	6.0 - 10.0	43 - 72
Injection pipe flare nut	2.5 - 3.0	18 - 22
Intake manifold	1.6 - 2.4	12 - 17
Exhaust manifold	1.6 - 2.4	12 - 17
Back plate	3.3 - 4.8	24 - 35
Flywheel	13.1 - 19.0	95 - 137
Damper	1.9 - 2.7	14 - 20

UNLESS OTHERWISE SPECIFIED

Grade 6T

6mm bolt/nut	0.7 - 1.0	5 - 7
8mm bolt/nut	1.6 - 2.3	12 - 17
10mm bolt/nut	3.2 - 4.7	23 - 34
12mm bolt/nut	5.6 - 8.2	41 - 59
14mm bolt/nut	7.7 - 10.5	56 - 76

Grade 8T and 8.8

6mm bolt/nut	.8 - 1.2	6 - 9
8mm bolt/nut	1.8 - 2.7	13 - 20
10mm bolt/nut	3.7 - 5.5	27 - 40
12mm bolt/nut	6.4 - 9.5	46 - 69
14mm bolt/nut	10.4 - 14.0	75 - 101

Grade 5 capscrew

1/4 UNC	1.2 - 1.5	9 - 11
1/4 UNF	1.5 - 1.8	11 - 13
5/16 UNC	2.5 - 2.8	18 - 20
5/16 UNF	2.9 - 3.2	21 - 23
3/8 UNC	3.7 - 4.6	28 - 33
3/8 UNF	4.1 - 4.8	30 - 35
7/16 UNC	6.1 - 6.8	44 - 49
7/16 UNF	6.9 - 7.6	50 - 55
1/2 UNC	9.4 - 10.1	68 - 73
1/2 UNF	10.1 - 11.1	73 - 80

YOUR NOTES

www.torresen.com

OTHER OVERHAUL

CONTENTS	SECTION	PAGE
MARINE ENGINE ELECTRICAL SYSTEM.....	Q	
Activation by Keyswitch (1980 onwards).....		102
COOLING SYSTEM EXTERNAL.....	R	107
TRANSMISSIONS.....	S	
Type HBW Short Profile Sailing Gear.....		113
Warner Hydraulic.....		122
Paragon Hydraulic.....		127
Walter V-drive.....		131

SECTION Q

MARINE ENGINE ELECTRICAL SYSTEM

ACTIVATION BY KEYSWITCH

This system is supplied on most Westerbeke engines beginning May, 1980. Essentially, activation of the circuit is accomplished by the ignition position of the keyswitch. No oil pressure switch is required. The engine is preheated by turning the keyswitch to the ON position, then depressing the key. The engine is cranked by turning the keyswitch to the right-most momentary position.

Voltage is maintained to the instruments, fuel solenoid or fuel lift pump, if supplied, and to other electrical devices via the ON position of the keyswitch.

Models which have a fuel solenoid may be turned off via the keyswitch. Models with mechanical fuel lift pumps or no fuel solenoid are stopped by pulling a stop cable. Some models have a combined throttle/shut-off control.

The circuit is protected by a circuit breaker located on the engine. Any time excessive current flows, the circuit breaker will trip. This is a manual reset breaker which must be reset before the engine will operate electrically again.

CAUTION: The builder/owner must ensure that the instrument panel, wiring and engine are installed so that electrical devices cannot come in contact with sea water.

The latest information regarding your engine's electrical system is included on the wiring diagram shipped with the engine. Be sure to study this wiring diagram and all notes thereon.

SECTION Q

ACTIVATION BY KEYSWITCH

SCHEMATIC DIAGRAM

WIRING DIAGRAM.

Rev. F

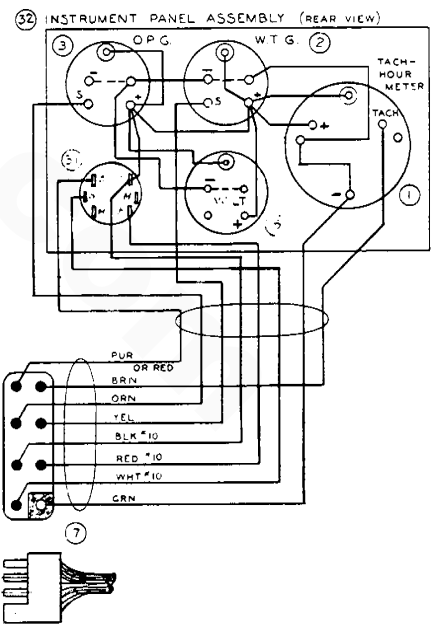
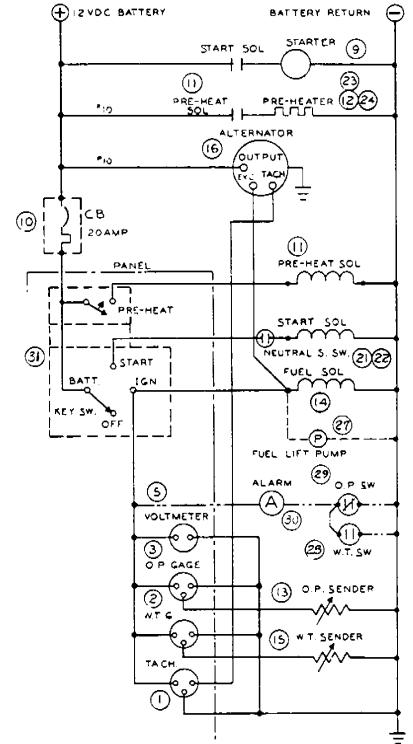
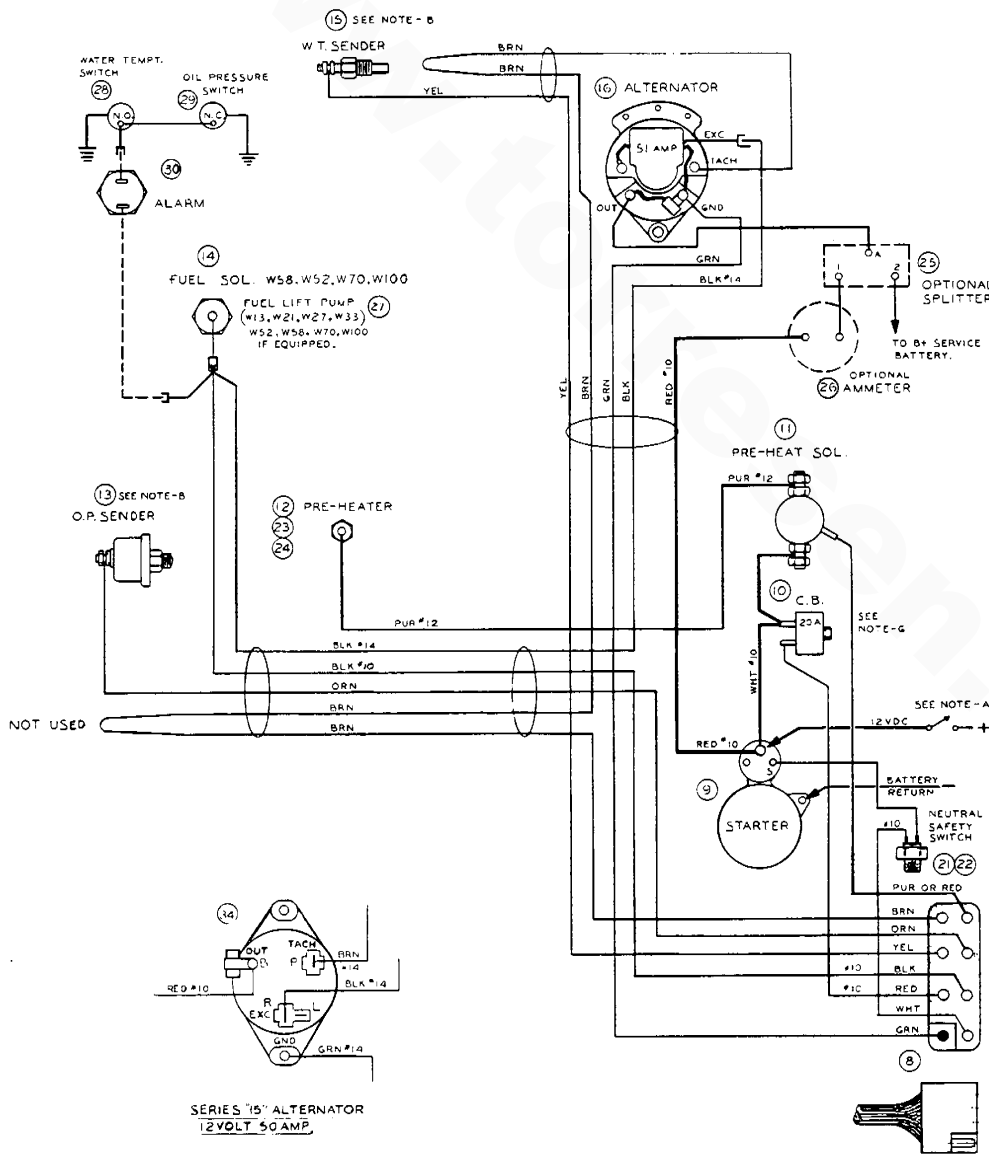

GLOWPLUG

A glowplug can be checked for an open circuit fault by using a circuit tester and checking the continuity between the positive terminal on top of the glowplug and the cylinder head. If there is no continuity, the glowplug should be replaced.

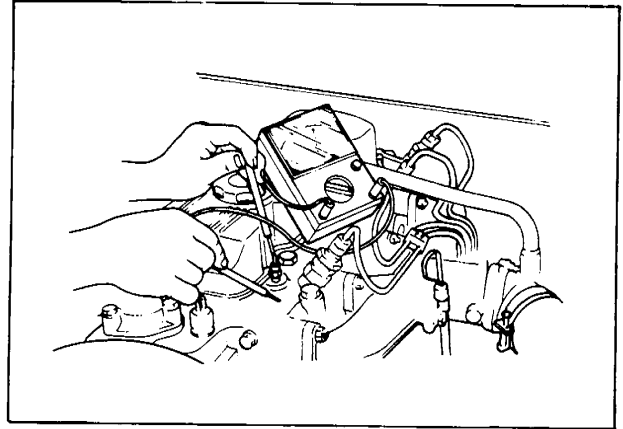

FUEL SHUT-OFF SOLENOID

The solenoid is located on the injection pump top near the rear. When the keyswitch is off, the solenoid releases the plunger and a spring forces the plunger down to stop the flow of fuel through the injection pump. When the switch is on, the solenoid is activated and pulls the plunger up to allow fuel to be injected. If the solenoid does not appear to operate properly, check the wiring connections and check for the flow of current to the solenoid. If the circuit checks normal, then the solenoid is probably defective and should be replaced as a unit.

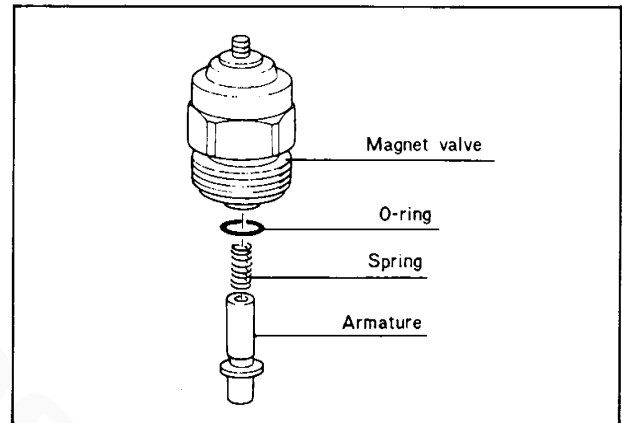

VOLTMETER

The voltmeter can be a useful instrument in determining the status of your electrical system and warn you when an abnormality occurs. The voltmeter will indicate differently, depending when the readings are taken.

Fully charged batteries that are in a static state should read between 12.3 and 12.6 volts on the dial. The term static means that the battery has not been charged or discharged for at least 2 hours. If the reading is between 11 and 11.5 volts, then the battery is about half discharged and should be charged to insure its usefulness. If the engine is started and the needle does not go up, this would indicate that no charge is being delivered to the battery.

When the battery is being charged, the needle should be between 12.6 and 13 volts. The needle may move up to about the 14.6 volt range toward the end of the charge cycle, at which time the needle drops back to the 12.6 to 13 volt range, as voltage regulation controls this function. If the battery voltage exceeds 15 volts, this indicates

that the battery is being overcharged and will damage the battery if left unchecked. The voltage regulator is most likely at fault.

When the battery is being charged, (having electrical loads placed upon it and no charging current applied), it is normal for the needle to indicate between 11.4 and 12.6 volts.

TACHOMETER

The tachometer is operated by pulses generated from any one of the alternator phases. The pulse frequency is determined by the rotational speed of the alternator rotor. The rotor speed is dependent upon the engine crankshaft speed and the RATIO of the alternator pulley to the crankshaft pulley. The tachometer in an instrument panel is calibrated by Westerbeke for the standard alternator; if an optional alternator (i.e., 90 amp) is used to operate the tachometer, the calibration should be checked. Also, when a tachometer is replaced, the new instrument must be calibrated.

CAUTION

WHEN CALIBRATING THE TACHOMETER, USE A PHILLIPS SCREWDRIVER WITH AN INSULATED SHAFT.

1. Use a motor tester with an RPM indicator, another tachometer or a strobo-tach to determine the speed of the crankshaft turning.
2. Remove the plastic plug and flatwasher located on the rear of the tachometer.
3. Insert an insulated Phillips screwdriver into the calibration control slot and slowly turn counterclockwise to increase the RPM reading, clockwise to decrease reading (direction of screw as viewed from the rear of the tachometer case). An accurate calibration setting is more easily achieved at the higher side of the dial scale.
4. Replace plastic plug and flatwasher.

SERVICE BULLETINS

Please refer to the Service Bulletin Section at the rear of the manual as there are several that relate to the electrical system.

WIRING DIAGRAM 90 AMP ALTERNATOR

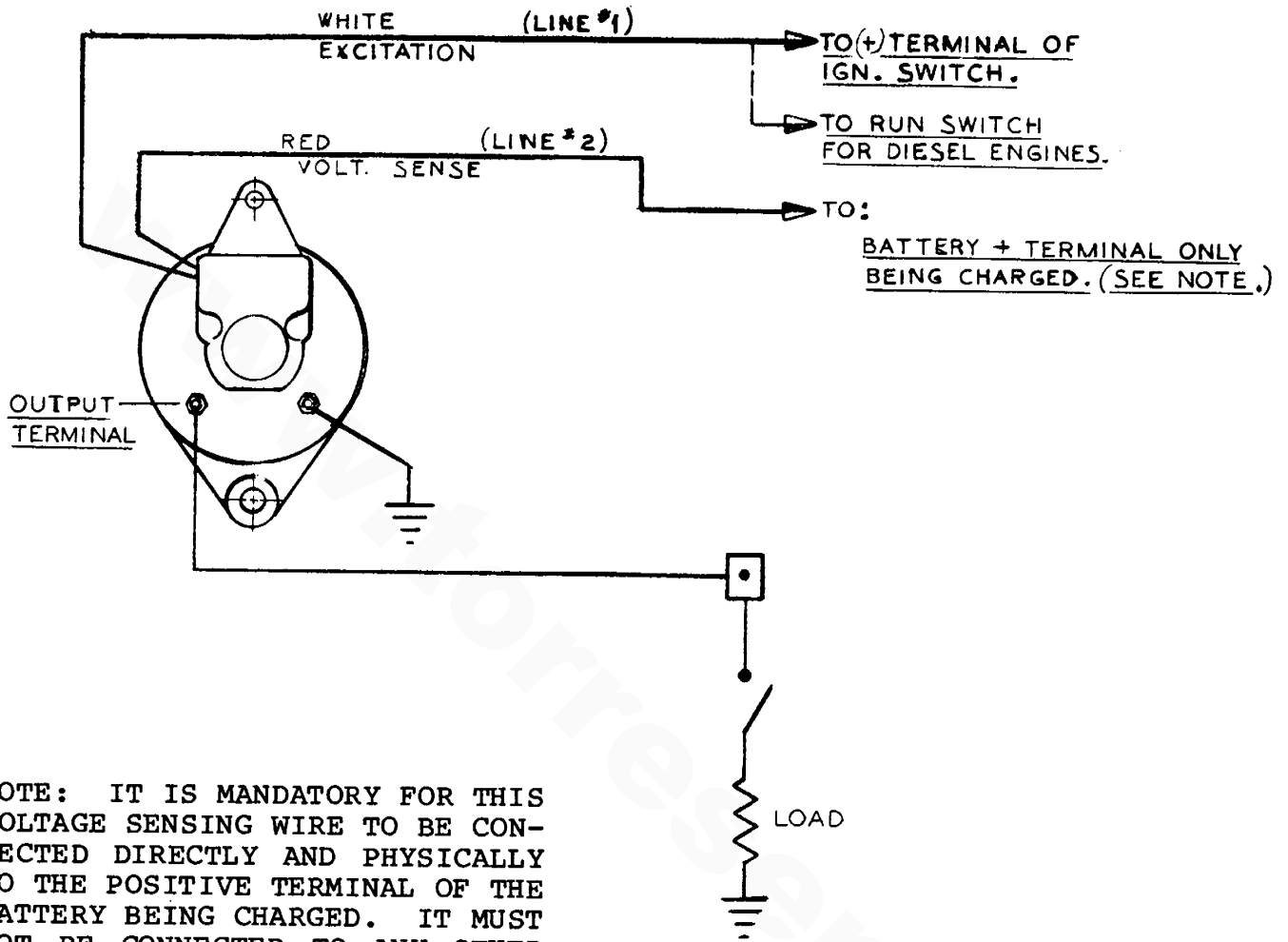

NOTE: IT IS MANDATORY FOR THIS VOLTAGE SENSING WIRE TO BE CONNECTED DIRECTLY AND PHYSICALLY TO THE POSITIVE TERMINAL OF THE BATTERY BEING CHARGED. IT MUST NOT BE CONNECTED TO ANY OTHER CONNECTION POINT. OTHERWISE, THE ALTERNATOR WILL NOT OPERATE PROPERLY.

CHECKING ALTERNATOR AFTER HOOK-UP

LINE #1	12.2 - 12.8V	12.2 - 12.8V	14.0 - 15.0V
LINE #2	0	3.0 - 5.0V	14.0 - 15.0V
OUTPUT	12.2 - 12.8V	12.2 - 12.8V	14.0 - 15.0V
	IGN OFF ENGINE NOT RUNNING	ENGINE NOT RUNNING IGN ON	ENGINE RUNNING (1500 RPM)

SECTION R

COOLING SYSTEM (EXTERNAL)

1. DESCRIPTION

Westerbeke marine diesel engines are equipped with fresh water cooling. Transfer of heat from engine fresh water to sea water is accomplished by a heat exchanger, similar in function to an automotive radiator. Sea water flows through the tubes of the heat exchanger while fresh water flows around the tubes. The sea water and fresh water never mix with the result that the cooling water passages in the engine stay clean.

2. FRESH WATER CIRCUIT

Heat rejected during combustion, as well as heat developed by friction, is absorbed by the fresh water whose flow is created by a fresh water circulating pump. The fresh water flows from the engine through a fresh water cooled exhaust manifold, a heat exchanger, in most cases an oil cooler, and returns to the suction side of the fresh water circulating pump. The flow is not necessarily in this order in every model. When starting a cold engine, most of the external flow to the heat exchanger is prevented by the closed thermostat. Some amount of by-pass is maintained to prevent overheating in the exhaust manifold. As the engine warms up, the thermostat begins to open up allowing full flow of engine fresh water through the external cooling system.

3. SEA WATER CIRCUIT

The sea water flow is created by a positive displacement neoprene impeller pump (gear pump in certain special cases). Normally the pump draws sea water directly from the ocean via the seacock and sea water strainer. Sometimes a transmission oil cooler, or perhaps a V-drive, will be piped on the suction side of the sea water pump. Generally, it is better to have as few devices on the suction side of the sea water pump as possible to preclude priming difficulties. Usually sea water flows directly from the discharge of the sea water pump to the heat exchanger sea water inlet. After passing through the tubes of the heat exchanger, the sea water may enter a transmission oil cooler, if present and if sea water cooled. Ultimately, the sea water enters a water injected, wet exhaust system, the most popular type of exhaust system in use. In the case of larger engines the sea water flow is divided prior to entering the exhaust systems so that a portion is used to cool the exhaust system. Full sea water flow would create unnecessary exhaust back pressure.

4. SEA WATER PUMP

The sea water pump is self priming and positive displacement. It is a rotary pump with a non-ferrous housing and a neoprene impeller. The impeller has flexible vanes which wipe against a curved cam plate within the impeller housing, producing the pumping action. On no account should this pump be run dry. There should always be a spare impeller and impeller cover gasket aboard.

5. SEA WATER PUMP IMPELLER REPLACEMENT

The following instructions are general and indicative only. Specific instructions where applicable may be packaged with your replacement impeller.

- a. Remove the front cover gasket taking care to salvage the gasket.
- b. Remove the impeller by pulling straight outwards, parallel to the pump shaft. This is best done with a pair of pliers applied to the impeller hub.
- c. Coat the replacement impeller and the chamber into which it mounts with grease.
- d. Carefully align the impeller key way, or other locking mechanism, with the shaft. Take care that all the impeller blades bend in the same direction and trailing.
- e. Inspect the front cover for wear. A worn front cover should ultimately be replaced. Sometimes it can be reversed as an emergency measure, but not when stamped markings would break the seal between the cover and the impeller blades.
- f. Reinstall the end cover with a new gasket.
- g. Be doubly sure to check quickly for sea water flow when starting the engine. The absence of flow indicates that the pump may not be priming itself properly. This situation must be investigated immediately or damage to the new impeller will result from overheating.

6. ENGINE FRESH WATER

It is preferable to fill your engine with a 50% antifreeze-water mixture. This precludes the necessity of draining coolant in the winter. Since most antifreezes contain preservative agents of one kind or another, rusting within the engine is minimized. Also, the antifreeze mixture boils at a higher temperature than water, giving cooling system "head room".

When draining the engine, open the pressure cap first to relieve the vacuum created by draining.

7. FILLING THE FRESH WATER SYSTEM

It is very important to completely fill the fresh water system before starting the engine. It is normal for air to become trapped in various passages so all high points must be opened to atmosphere to bleed entrapped air. When an engine is started after filling with coolant, the system may look deceptively full until the thermostat opens. At this time when water flows through the external cooling circuit for the first time, pockets of air can be exposed and rise to the fill point. Be sure to add coolant at this time.

8. THERMOSTAT

Generally, thermostats are of two types. One is simply a choking device which opens and closes as the engine temperature rises and falls. The second type has a by-pass mechanism. Usually this is a

disc on the bottom of the thermostat which moves downward to close off an internal by-pass passage within the head. Both types of thermostats, from 1980 onwards, have a hole punched through them to serve as a by-pass while the engine is warming up. This prevents overheating in the exhaust manifold during engine warm-up. Replacement thermostats must be equal in this design characteristic.

When replacing a thermostat, be sure that it is rotated so as to not strike the thermostat housing, projections inside the head, temperature senders or temperature switches which may be installed close to the thermostat. Also insure the by-pass hole is not blocked by any part of the housing.

A thermostat can be checked for proper operation by placing it in a pan of cold water and then raising the temperature of the water to a boil. The thermostat should open noticeably (with travel on the order of 1/4" - 1/2") and be fully opened when the water is boiling.

9. ENGINE LUBE OIL COOLER

Lubricating oil carries heat away from the engine bearings and other friction surfaces. The oil circulates from the lube oil pump, through the engine, through the engine oil cooler, and back to the oil pump.

The oil cooler may be cooled either by engine fresh water or by sea water.

10. TRANSMISSION OIL COOLER

Certain transmissions require oil cooling. In these cases, the transmission oil cooler is usually cooled by sea water.

Normally, sea water enters this cooler after exiting the heat exchanger, but not always.

11. EXHAUST MANIFOLD - EXTRUDED TYPE

REMOVAL

Removal of the exhaust manifold from the engine should be done as a complete assembly in the following manner.

- a. Drain the engine and cooling system of all coolant.
- b. Remove the exhaust connection.
- c. Loosen and remove all hose connections to the manifold.
- d. Loosen and remove the nuts or bolts attaching the manifold assembly to the cylinder head.
- e. Remove the manifold from the cylinder head as a complete unit.

SERVICING

- a. Remove the exhaust elbows from the lower surface of the manifold. Clean and inspect for cracks and defects. Replace as needed.
- b. Remove exhaust nipples, elbows and plugs from the manifold.
- c. Remove water connectors from the ends of the manifold and the end plates. Be sure to note the proper location and arrangement of each for proper replacement.
- d. Examine all parts for defects, corrosion and wear and replace as needed.

REASSEMBLY

- a. If the manifold was removed as an assembly and left intact, it can be replaced on the cylinder head in the reverse order of removal. Do not reuse the gaskets; install new ones and torque the bolts or nuts to the proper specification (10-12 lb-ft).
- b. If the manifold has been disassembled, follow the steps below.
 1. Loosely attach the elbows to the cylinder head and the manifold using new gaskets. Do not use any gasket sealant.
 2. Gradually tighten each fitting to make sure of proper alignment of all the parts. This should be done in three steps. Torque to 10-12 lb-ft.
 3. Reassemble the end plates, connectors on the manifold. Be sure to use new gaskets and coat the gasket surfaces with a suitable gasket cement such as "High Tack". Torque the nuts to 8-10 lb-ft.
 4. Reinstall the exhaust connections and plug into the manifold using "Loctite-Anti-Seize" on the threads.
 5. Reconnect all hoses, replacing them as needed.
 6. Refill the system with coolant as detailed above.
 7. Pressure test system and check for leaks.

TWO PASS MANIFOLD

Note: Drawing is indicative only. Specific models may vary in detail.

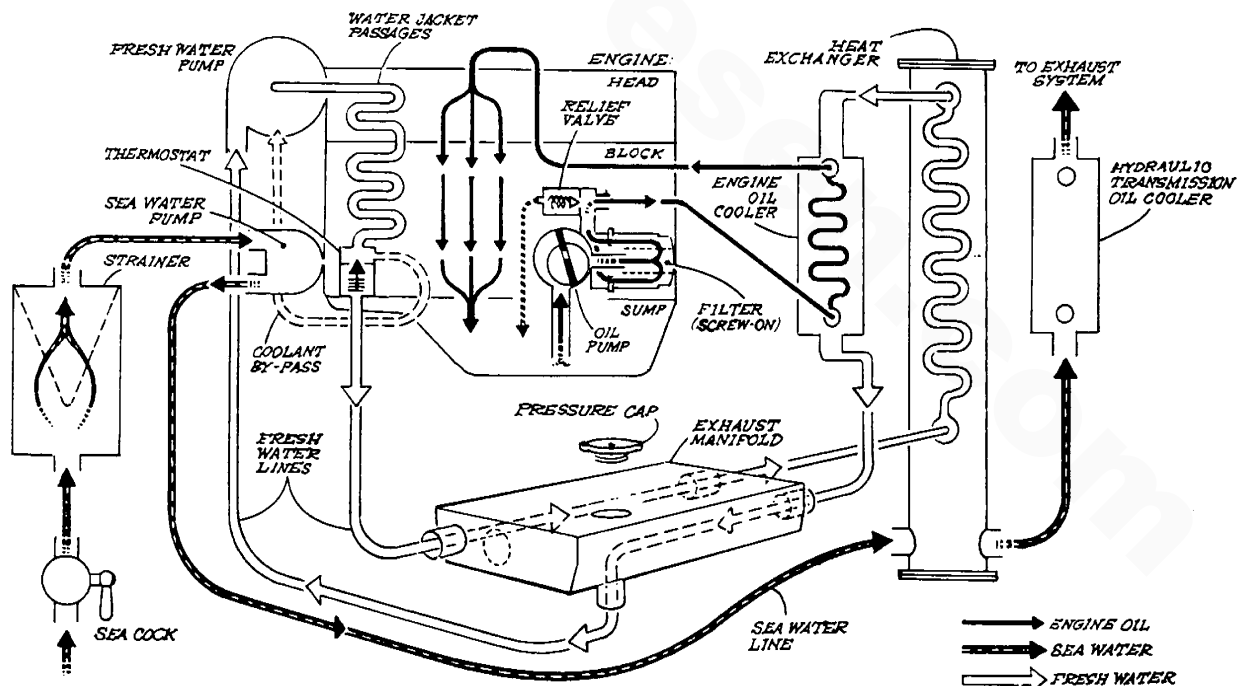

SINGLE PASS MANIFOLD

Note: Drawing is indicative only. Specific models may vary in detail.

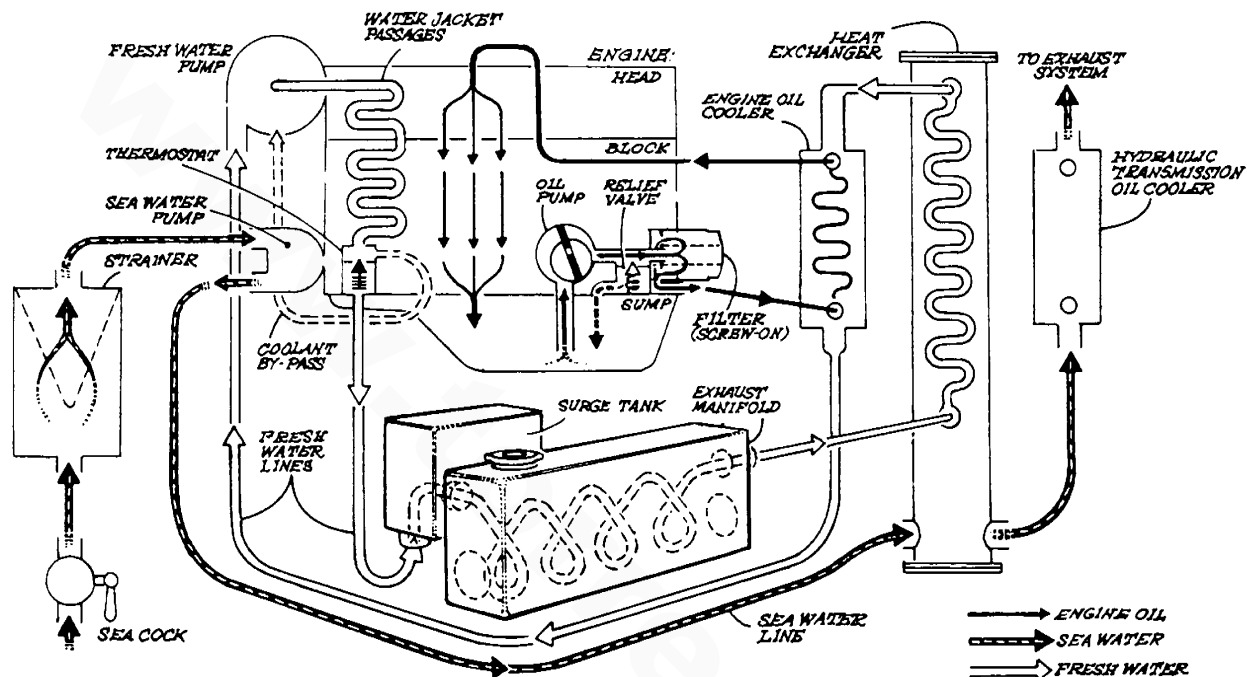

SECTION S

TRANSMISSIONS

HBW SHORT PROFILE SAILING GEAR

DESCRIPTION

1. BRIEF DESCRIPTION

The Type HBW Short Profile Sailing Gears are equipped with a positively driven, mechanically operated helical gearing system. The servo-operated multiple-disc clutch requires only minimum effort for gear changing, making the transmission suitable for single-lever remote control via a rod linkage, Morse or Bowden cable.

The torque transmission capacity of the clutch is exactly rated, preventing shock loads from exceeding a predetermined value and thus ensuring maximum protection of the engine.

The transmission units are characterized by low weight and small overall dimensions. The gearbox castings are made of a high-strength, corrosion-resistant aluminum alloy, chromized for improved sea water resistance and optimum adhesion of paint.

The transmissions are immersion-lubricated. Maintenance is restricted to oil level checks (see "Maintenance").

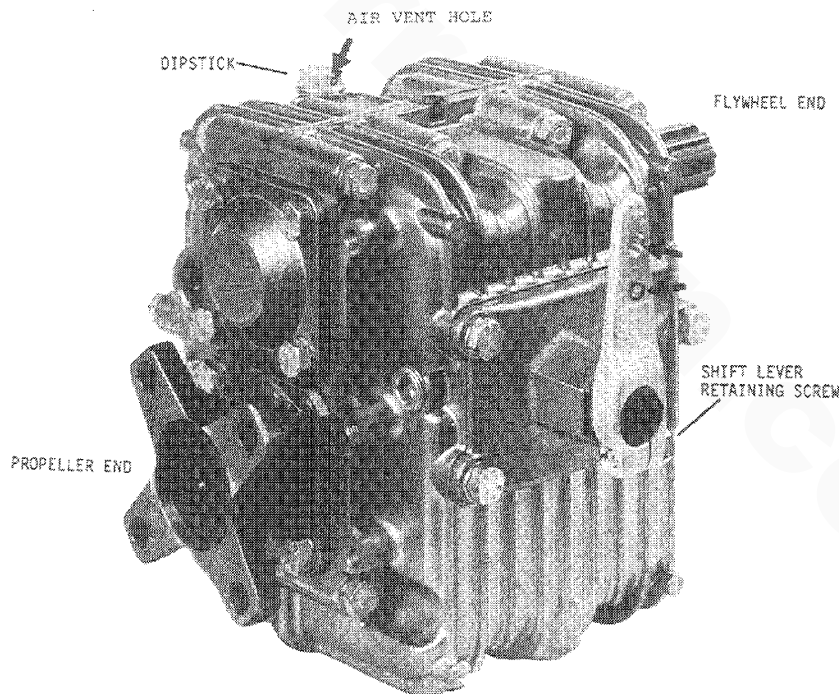

2. GEAR CASING

The rotating parts of the HBW transmission are accommodated in an oil-tight casing divided into two halves in the plane of the vertical

axis. Amply dimensioned cooling ribs ensure good heat dissipation and mechanical rigidity.

An oil filler screw with dipstick and an oil drain plug are screwed into the gear casing. The filler screw is provided with a breather hole.

The shaft for actuating the multiple-disc clutch extends through a cover on the side of the gear casing.

3. GEAR SETS

The transmission is equipped with shaved, casehardened helical gears made of forged low-carbon alloy steel. The multi-spline driving shaft connecting the transmission with the engine is hardened as well.

The driven shaft (propeller side) of the transmission is fitted with a forged coupling flange, except on the V-drive model.

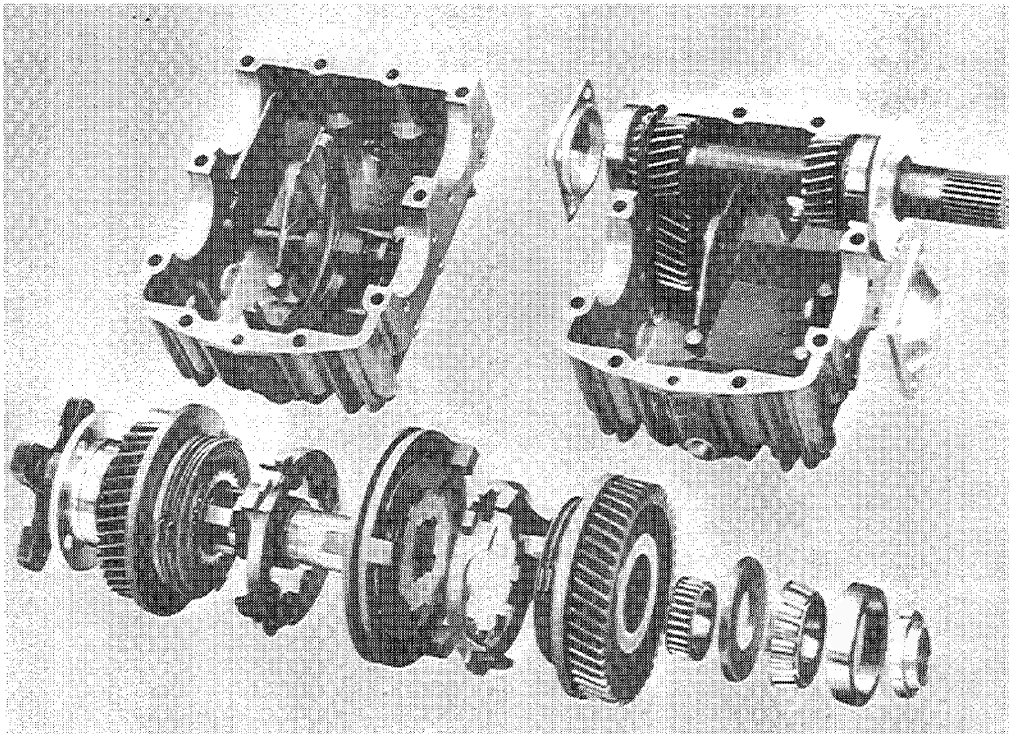

4. MULTIPLE-DISC CLUTCH INCLUDING OPERATION - POWER TRAIN

The engine torque is applied to the input shaft (36) in the specified direction of rotation and, IN SHIFTING POSITION A (forward), via gear (44), the frictionally engaged clutch discs (51 and 52) to the external disc carrier (57) and from there via the guide sleeve (59) to the output shaft (66).

IN SHIFTING POSITION B (reverse), the torque is transmitted from the input shaft (36) via intermediate gear (26), gear (65), clutch discs (51 and 52) to the external disc carrier (57), the guide sleeve (59) and the output shaft (66).

- FUNCTION

The transmission uses a positively driven, mechanically operated multiple-disc clutch system mounted on the output shaft.

The thrust force required for obtaining positive frictional engagement between the clutch discs is provided by a servo system. This essentially comprises a number of balls which, by the rotary movement of the external disc carrier, are urged against inclined surfaces provided in pockets between the guide sleeve and the external disc carrier and in this manner exert axial pressure. The thrust force and, as a result, the transmittable friction torque are thus proportional to the input torque applied. Due to the cup springs (48) supporting the clutch disc stack and a limitation of the range of axial travel of the external disc carrier (57), the thrust force cannot exceed a predetermined value.

The actuating sleeve (60) is held in the middle position by spring-loaded pins. To initiate the shifting operation, the actuating sleeve (60) need merely be displaced axially by a shifting fork until the arresting force has been overcome. Then the actuating sleeve (60) is moved automatically by the spring-loaded pins, while the external disc carrier, which follows this movement, is rotated by the frictional forces exerted by the clutch discs, and the shifting operation is completed as described above.

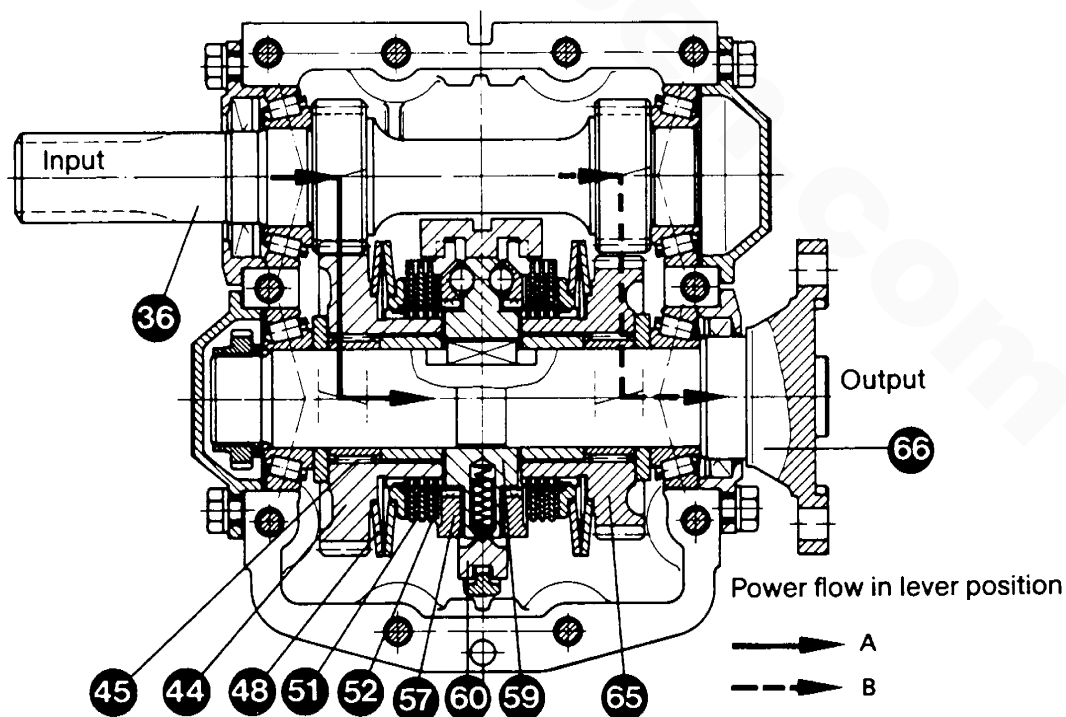

5. SHAFT BEARINGS

Both the input and the output shafts are carried in amply dimensioned taper roll bearings.

The intermediate gear and the movable gears are carried in sturdy needle roller bearings.

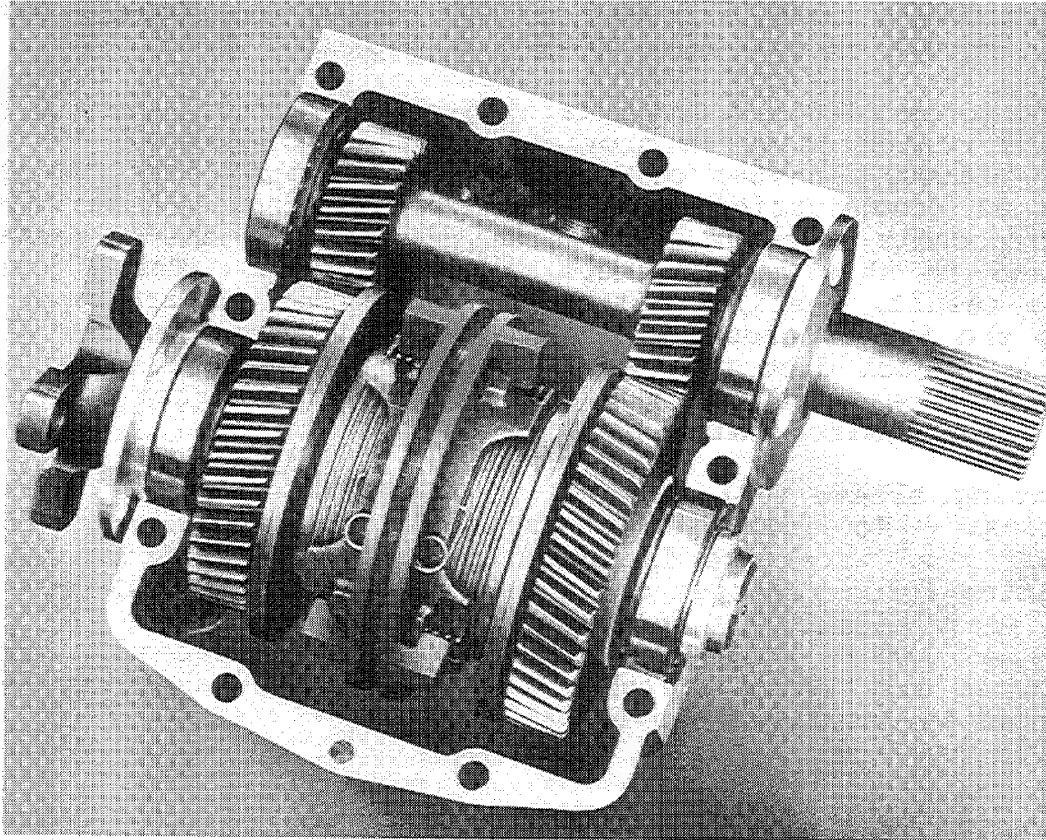

6. SHAFT SEALS

External sealing of the input and output shafts is provided by radial sealing rings. The running surface on the shafts is casehardened.

7. LUBRICATION

The transmissions are immersion-lubricated. The bearings are generously supplied with splash oil and oil mist.

INSTALLATION

1. DELIVERY CONDITION

For safety reasons, the gearbox is NOT filled with oil for shipment. The actuating lever is mounted on the actuating shaft.

Before leaving the factory, each transmission is subjected to a test run with the prescribed ATF oil. The residual oil remaining in the

transmission after draining acts as a preservative and provides reliable protection against corrosion for at least 1 year if the units are properly stored.

2. PAINTING THE GEARBOX

ALWAYS COVER THE RUNNING SURFACES AND SEALING LIPS OF THE RADIAL SEALING RINGS ON BOTH SHAFTS BEFORE PAINTING. Make certain that the breather hole on the oil filler screw is not closed by the paint. Indicating plates should remain clearly legible.

3. CONNECTION OF GEARBOX WITH ENGINE

A torsio-elastic damping plate between the engine and the transmission is to compensate for minor alignment errors and to protect the input shaft from external forces and loads. Radial play should be at least 0.5 mm.

4. SUSPENSION OF ENGINE-GEARBOX ASSEMBLY IN THE BOAT

To protect the gearbox from detrimental stresses and loads, provision should be made for elastic suspension of the engine-gearbox assembly in the boat or craft.

The oil drain plug of the gearbox should be conveniently accessible.

5. POSITION OF GEARBOX IN THE BOAT

The inclination of the gearbox unit in the direction of the shafts should not permanently exceed an angle of 20 degrees (15 degrees for the V-drive model). (See illustration.)

The gearbox can also be mounted with the output shaft in the UPWARD position. Interchange the oil dipstick and the oil drain plug in this case.

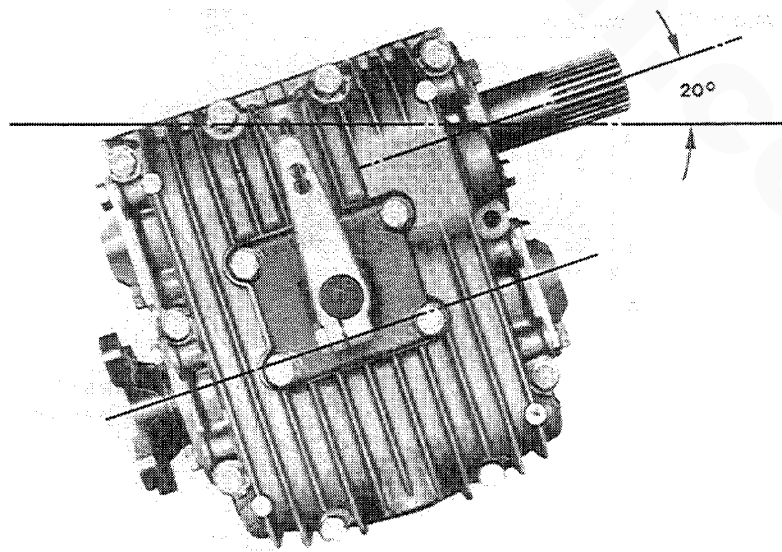

6. OPERATION OF GEARBOX

Gear changing requires only minimum effort. The gearbox is suitable for single lever remote control. Upon loosening the retaining screw, the actuating lever (see illustration) can be moved to any position required for the control elements (cable or rod linkage). Make certain that the lever does not contact the actuating lever cover plate (9): the minimum distance between lever and cover should be 0.5 mm.

The control cable or rod should be arranged at right angles to the actuating lever in the neutral position of the lever.

A larger amount of lever travel is in no way detrimental.

However, if the lever travel is shorter, proper gear engagement might be impeded which, in turn, would mean premature wear, excessive heat generation and resulting damage.

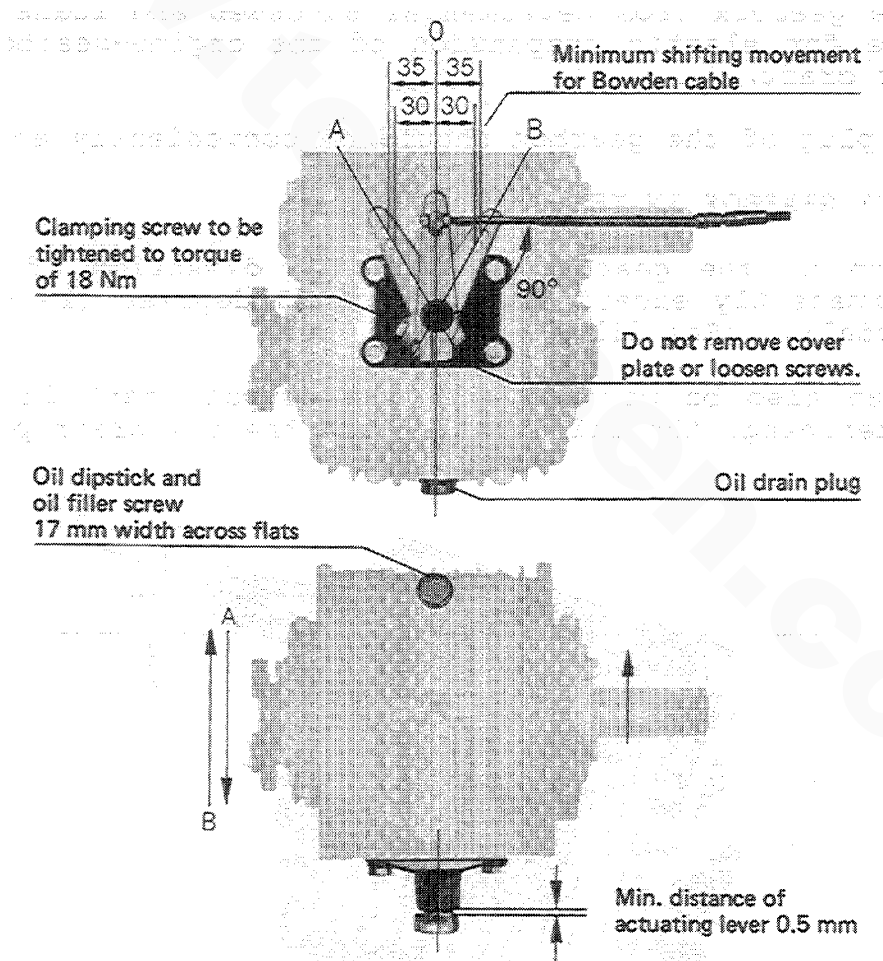

3. OPERATION OF GEARBOX

The zero position of the operating lever on the control console must coincide with the zero position of the actuating lever on the transmission. Shifting is initiated by a cable or rod linkage via the actuating lever and an actuating cam. The completion of the gear changing operation is servo-automatically controlled.

Gear changing should be smooth, not too slow, and continuous (without interruption). Direct changes from forward to reverse are permissible, since the multiple-disc clutch permits gear changing at high RPM, including sudden reversing at top speeds in the event of danger.

4. OPERATION WITHOUT LOAD

Rotation of the propeller without load, e.g. while the boat is sailing, being towed, or anchored in a river, as well as idling of the engine with the propeller stopped, will have no detrimental effects on the gearbox.

Locking of the propeller shaft by an additional brake is not required, since locking is possible by engaging the reverse gear. Do not sail while engaged in forward.

5. LAY-UP PERIODS

If the transmission is not used for periods of more than 1 year, it should be COMPLETELY filled with oil of the same grade to prevent corrosion. Protect the input shaft and the output flange by means of an anticorrosive coating if required.

6. PREPARATION FOR RE-USE

Drain the transmission of all oil and refill to the proper level with the prescribed oil.

MAINTENANCE

1. TRANSMISSION OIL

To ensure trouble-free operation of the clutch, use only automatic transmission fluid (ATF).

Under no circumstances should the oil contain any additives such as molybdenum sulphite.

We recommend commercial Automatic Transmission Fluid (ATF), Type A or Dexron II.

2. OIL QUANTITY

HBW 5 approximately 0.4 liter
HBW 10 approximately 0.6 liter
HBW 20 approximately 0.8 liter
HBW 50 approximately 0.3 liter
HBW 100 approximately 0.35 liter
HBW 150 approximately 0.55 liter
HBW 150V approximately 1.0 liter
HBW 220 approximately 0.75 liter
HBW 250 approximately 0.75 liter
HBW 360 approximately 1.40 liter
HBW 360A approximately 1.50 liter
HBW 400 approximately 2.00 liter
HBW 450 approximately 1.80 liter

Use the index mark on the dipstick as a reference.

3. OIL LEVEL CHECKS

Check the oil level in the transmission daily. Correct oil level is the index mark on the dipstick (see item 1 under OPERATION). Always use the same oil grade when topping up.

4. OIL CHANGE

Change the oil for the first time after about 25 hours of operation, then at intervals of at least once per year.

5. CHECKING THE CABLE OR ROD LINKAGE

The cable or rod linkage should be checked at shorter time intervals. Check the zero position of the operating lever (on the control console) and of the actuating lever (on the gearbox) on this occasion. The minimum lever travel from the neutral position to the operating positions (0-A = 0-B) should be 35 mm for the outer and 30 mm for the inner pivot point. Make certain that these minimum values are safely reached. Check the cable or rod linkage for easy movability (see item 6 under INSTALLATION).

6. OVERHAUL

Disassembly of the transmission in the field is not recommended. If an overhaul or repair is needed, the work should be done by Westerbeke or an authorized Westerbeke service center.

WARNER HYDRAULIC

1. DESCRIPTION

Westerbeke engines are also furnished with Warner hydraulic direct drive and reduction gear assemblies.

The direct drive transmission consists of a planetary gear set, a forward clutch, a reverse clutch, an oil pump and a pressure regulator and rotary control valve. All of these are contained in a cast iron housing along with necessary shafts and connectors, to provide forward, reverse and neutral operation. A direct drive ratio is used for all forward operation. In reverse, the speed of the output shaft is equal to the input shaft speed, but in the opposite direction. Helical gearing is used to provide quieter operation that can be obtained with spur gearing.

Oil pressure is provided by the crescent type pump, the drive gear of which is keyed to the drive shaft and operates at transmission input speed to provide screened oil to the pressure regulator.

From the regulator valve the oil is directed through the proper circuits to the bushings and anti-friction bearings requiring lubrication. A flow of lubricant is present at the required parts whenever the front pump is turning and, it should be noted that supply is positive in forward, neutral and reverse conditions.

The unit has seals to prevent the escape of oil.

Both the input and output shafts are coaxial, with the input shaft splined for the installation of a drive damper, and the output shaft provided with a flange for connecting to the propeller shaft.

2. CONTROL LEVER POSITION

The position of the control lever on transmission when in forward should be shifted to the point where it covers the letter "F" on the case casting, and is located in its proper position by the poppet ball. The Warranty is cancelled if the shift lever poppet spring and/or ball is permanently removed, or if the the control lever is changed in any manner, or repositioned, or if linkage between remote control and transmission shift lever does not have sufficient travel in both directions. This does not apply to transmissions equipped with Warner Gear electrical shift control.

3. LUBRICATION

The properties of the oil used in the transmission are extremely important to the proper function of the hydraulic system. Therefore, it is extremely important that the recommended oil, automatic transmission fluid (ATF), Type A be used.

NOTE: Be sure the cooler is properly installed and the transmission contains oil before cranking or starting the engine.

4. CHECKING OIL LEVEL

The oil level should be maintained at the full mark on the dipstick. Check oil level prior to starting engine.

5. FILLING AND CHECKING THE HYDRAULIC SYSTEM

Check daily before starting engine. The hydraulic circuit includes the transmission, oil cooler, cooler lines and any gauge lines connected to the circuit. The complete hydraulic circuit must be filled when filling the transmission and this requires purging the system of air before the oil level check can be made. The air will be purged from the system if the oil level is maintained above the pump suction opening while the engine is running at approximately 1500 RPM. The presence of air bubbles on the dipstick indicates that the system has not been purged of air.

New applications or a problem installation should be checked to insure that the oil does not drain back into the transmission from the cooler and cooler lines. Check the oil level for this drain back check only, immediately after the engine has been shut off and again after the engine has been stopped for more than one hour (overnight is excellent). A noticeable increase in the oil level after this waiting period indicates that the oil is draining from the cooler and cooler lines. The external plumbing should be changed to prevent any drain back.

6. STARTING ENGINE

Place transmission selector in neutral before starting engine. Shifts from any selector position to any other selector position may be made at any time and in any order if the engine speed is below 1000 RPM; however, it is recommended that all shifts be made at the lowest feasible engine speed.

7. NEUTRAL

Move the shift lever to the center position where the spring-loaded ball enters the chamfered hole in the side of the shift lever and properly locates lever in neutral position. With shift lever so positioned, flow of oil to clutches is blocked at the control valve. The clutches are exhausted by a portion of the valve and complete interruption of power transmission is insured.

8. FORWARD

Move the shift lever to the extreme forward position where the spring-loaded ball enters the chamfered hole in the side of the shift lever and properly locates lever in forward position.

9. REVERSE

Move transmission shift lever to the extreme rearward position where the spring-loaded ball enters the chamfered hole in the side of the shift lever and properly locates it in the reverse position.

10. FREEWHEELING

Under sail with the propeller turning, or at trolling speeds with one of two engines shut down, the design of the gear maintains adequate cooling and lubrication.

11. COOLING PROBLEMS

Water passages inside of the cooler will sometimes become clogged, and this will reduce cooling capacity and cause overpressuring. Back flushing of the cooler will sometimes help to flush the foreign material from the cooler passages. The cooler and hose should be thoroughly flushed or replaced in the event a failure has occurred. Metallic particles from the failure tend to collect in the case of the cooler and gradually flow back into the lube system. Replace oil cooler to prevent contamination of the new transmission.

Water hoses may collapse and reduce or completely shut off all flow to the cooler. Collapsed hoses are usually caused by aging of the hoses or improper hose installation. Hose installation should be made with no sharp bends. Hoses should be routed so there is no possibility for engine shifting to cause hoses to pull loose or become pinched. A visual inspection of hoses while under way will sometimes allow detection of faulty hoses.

Reduction or complete loss of water flow can be caused by a faulty water pump. A rubber water pump impeller will sometimes fail and after such a failure the cooler passages may be restricted by the particles of rubber from the failed impeller. Water pump cavitation may be caused by improper or faulty plumbing or an air leak on the inlet side of the pump. The water pump may not prime itself or may lose its prime when inlet plumbing is not properly installed.

It is possible for cross leaks to occur inside the cooler, permitting oil to flow into the water or water flow into the oil.

ROUTINE CHECKS AND MAINTENANCE

ANNUAL CHECKS

1. **PROPELLER AND OUTPUT SHAFT ALIGNMENT:** This check should also be made any time the propeller strikes a heavy object and after any accident where the boat is stopped suddenly. Shaft alignment should also be checked after the boat has been lifted by a hoist or moved on a trailer.
2. **SHIFT LEVER POSITIONING:** The selector controls must position the shift lever exactly in F, N and R selection positions with the ball poppet centered in the shift lever hole for each position.
3. **BOLT TORQUE:** Check all bolts for tightness.
4. **COOLER CONNECTIONS:** Check water lines, oil lines and connections for leakage. Make sure lines are securely fastened to prevent shifting.
5. **CHANGING OIL:** A seasonal oil change is recommended in pleasure boats. Work boats require more frequent changes. Change oil any time the oil becomes contaminated, changes color or becomes rancid smelling.
6. **TRANSMISSION FLUID:** Automatic transmission fluids are recommended for use in all transmissions.

DAILY CHECKS

1. Check transmission oil level.
2. Check for any signs of oil leakage in the bellhousing, at gasket sealing surfaces or at the output shaft oil seal.
3. A quick visual check of the general condition of the equipment may cause faulty equipment to be detected.
4. Listen for any unusual noises and investigate to determine the cause of any such noises.

WINTER STORAGE

1. Drain water from transmission oil cooler. This will prevent freezing in cooler climates, and prevent harmful deposits from collecting.

GENERAL CHECKS

1. Check coupling alignment each time a transmission is replaced in the boat.

2. Check shift linkage adjustment to insure that the transmission shift lever is positioned so that the spring loaded ball enters the chamfered hole in the side of the shift lever.
3. Connect an oil cooler into the cooler circuit before cranking or starting the engine. Various cooler circuits have been used and the correct cooler connections should be found from service literature prior to making the cooler installation.
4. Use a cooler of sufficient size to insure proper cooling.
5. Check engine rotation and transmission pump setting and the propeller rotation prior to assembling the transmission to engine.
6. Check oil pressure and temperature when transmission function indicates that a problem exists.
7. Use the recommended fluid for filling the transmission.
8. Fill the transmission prior to starting the engine.
9. Check oil level immediately after the engine has been shut off.
10. Use a clean container for handling transmission fluid.
11. Replace cooler line after a transmission failure, prior to installing a new or rebuilt transmission.
12. Check fluid level at operating temperature.

PARAGON HYDRAULIC

1. INSTALLATION

The installation instructions below are for use when the original transmission has been removed for servicing and must be reinstalled, or when the transmission unit is to be adapted as non-original equipment to a marine engine.

It is important that the engine and transmission rotations are matched. The direction of rotation of an engine is defined in this manual as the direction of rotation of the engine crankshaft as viewed from the output end of the transmission. A clockwise rotation of the engine is a right hand rotation and a counter-clockwise rotation of the engine is a left hand rotation.

A letter "R" or "L" appearing on the transmission serial number plate indicates whether the transmission is for use with a right or left hand rotating engine.

The hydraulic transmission is attached to the engine in the following manner:

- A. Insert two 3-1/2" studs in opposite transmission mounting holes in the flywheel housing.
- B. Place the transmission against the studs so that the studs go through two of the matching holes in the transmission housing flange.
- C. Slide the transmission along the studs toward the engine so that the spline on the shaft at the front of the transmission enters the matching splined hole in the engine vibration dampener.
- D. Install and tighten four bolts with lockwashers through the transmission housing flange into the flywheel housing. Remove the 3-1/2" studs. Install and tighten the two remaining bolts with lockwashers through the transmission housing flange.

The transmission and propeller shaft coupling must be carefully aligned before the propeller shaft is connected to the transmission, in order to avoid vibration and consequent damage to the transmission, engine and boat hull during operation. To align the coupling, move the propeller shaft, with attached coupling flange, toward the transmission so that the faces of the propeller shaft coupling flange and transmission shaft coupling flange are in contact. The coupling flange faces should be in contact throughout their entire circumference. The total runout or gap between the faces should not exceed .002" at any point. If the runout exceeds .002", reposition the engine and attached transmission by loosening the engine support bolts and adding or removing shims to raise or lower either end of the engine. If necessary, move the engine sideways to adjust the runout or to align the coupling flange faces laterally. Tighten the engine support bolts and recheck the alignment of the coupling before bolting

the coupling flanges together. Connect the coupling flanges with bolts, lockwashers and nuts.

Connect the oil cooler lines to the transmission.

Connect the shift control cable from the cockpit control station to the transmission control valve lever. Place the transmission control valve lever in the neutral position and adjust the shaft control cable length until the cockpit control station hand lever is in the neutral position. Move the cockpit control hand lever to forward and reverse positions several times while observing the transmission control valve lever motion. The transmission control valve lever should move fully into forward or reverse position when the hand lever is moved into forward or reverse position, and should return exactly to the neutral position when the hand lever is in the neutral position.

Remove the oil dipstick and fill the transmission with Type A transmission fluid to the mark on the dipstick. Replace the dipstick in the transmission housing.

2. OPERATION

PRINCIPLE OF OPERATION: The transmission forward and reverse drives are operated by transmission oil under pressure. An internal gear type oil pump delivers the transmission oil, under pressure to the external oil cooler. The transmission oil is returned, still under pressure, to the oil distribution tube and relief valve. The relief valve maintains the oil pressure by remaining closed until the oil pressure reaches 60 PSI. When the control lever is shifted to the forward position, oil under pressure is delivered to the multiple disc clutch piston, which moves to clamp the clutch discs and planetary reverse gear case together. The discs and case then revolve as a solid coupling in the direction of engine rotation. The reverse drive is engaged by shifting the control lever to the reverse position, so that oil under pressure is delivered to the reverse piston. The reverse piston moves to clamp the reverse band around the planetary gear case, preventing the planetary gear case from moving but allowing the planetary gears to revolve to drive the output or propeller shaft in a direction opposite to the rotation of the engine. With the control lever in the neutral position, pressurized oil is prevented from entering the clutch piston or reverse band piston and the propeller shaft remains stationary.

STARTING PROCEDURE:

- A. Always start the engine with the transmission in NEUTRAL to avoid moving the boat suddenly forward or back.
- B. When the engine is first started, allow it to idle for a few moments. Stop the engine and check the transmission oil level. Add oil if necessary to bring the oil level up to the mark on the transmission dipstick.

NOTE: ON SUBSEQUENT START-UPS, THE TRANSMISSION OIL LEVEL MAY BE CHECKED BEFORE RUNNING THE ENGINE, WHEN ENGINE OIL IS CHECKED.

- C. Start the engine again, with the transmission in NEUTRAL, and allow the engine to warm up to operating temperature.
- D. Shift the transmission into FORWARD or REVERSE as desired. If the engine should stall when the transmission is shifted to FORWARD or REVERSE, place the transmission in neutral before restarting the engine.

It is recommended that shifting be done at speeds below 1000 RPM, and preferably in the 800 RPM or idle engine range, to prolong the life of the engine, transmission and boat. EMERGENCY shifts may be made at higher engine speeds, but this is not a recommended practice.

3. MAINTENANCE

LUBRICATION: The transmissions are self-contained units, independent of the engine lubricating systems. The units are lubricated by pressure and by splash from its own oil. The type of oil recommended is "Transmission Fluid, Type A", commonly used for automatic transmissions in automobiles.

The quantity of oil depends upon the angle of installation as well as the reduction model. The level must be maintained at the mark on the dipstick and should be checked periodically to ensure satisfactory operation.

When filling for the first time or refilling after an oil change, check the level after running for a few minutes to make certain that the oil cooler and the various passages are full. If necessary, refill to the mark on the dipstick to ensure proper operation of the transmission. The transmission oil level should be checked each time the engine oil level is checked, before running the engine.

The oil in the transmission should be changed every 100 hours, or each season under normal conditions. However, the number of hours that can be run between oil changes varies with the operating conditions. Drain plugs are located at the bottom of the reverse gear housing and the reduction gear housing.

ADJUSTMENTS: No adjustment is necessary for the FORWARD drive multiple disc clutches, and the reverse band is self-adjusting to compensate for lining wear, so that no external reverse band adjustment is necessary.

YOUR NOTES

www.torresen.com

WALTER V-DRIVES

FLANGE ALIGNMENT - DIRECT COUPLED MODELS

Install the propeller shaft flange on to the propeller shaft and tighten the two clamping bolts on the split hub (none on RV-10D). A self-locking set screw is provided for the propeller shaft flange. Spot drill the propeller shaft and then securely tighten the set screw. Many good installations are ruined by improper shaft flange alignment. Accurate alignment will ensure a smooth operating drive train and eliminate many problems that arise due to misalignment. Final alignment should not be attempted until the boat has been allowed to "settle" in the water. After the engine has been installed, adjust the mounts per manufacturer's instructions until the pilot diameters of the gear shaft flange and the propeller shaft flange engage freely. Butt the flange faces together. Without rotating either flange, check with a feeler gauge in at least four places as shown in the illustration. If the maximum feeler gauge that can slip between the flange faces at any point is $.003"$, the unit is properly aligned. If a thicker gauge can be inserted at any point, the engine must be readjusted until proper alignment is obtained. Turn the propeller shaft flange $1/4$ of a turn without moving the gear shaft change. Try inserting the $.003"$ feeler gauge as described above. The gap will not change if the propeller shaft is straight. If it increases, the shaft or flange is bent and must be removed and straightened. Rotate the propeller shaft flange in two more $1/4$ turn increments and repeat the procedure. The pilot diameters must be rechecked to ensure that they still engage freely. Secure the two flanges together with the heat treated bolts and special high collared lockwashers supplied.

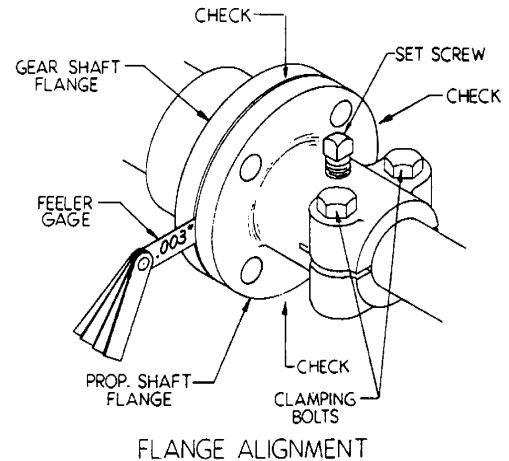

ENGINE ALIGNMENT - INDEPENDENT MODELS

The engine must be adjusted so that the alignment of the flexible joint is within 3° . An accurate steel rule should be used for this purpose as shown in the illustration. On short installations using a flexible joint assembly, the faces of the flexible joint must be parallel within $1/8"$. Measure this in at least four places around the diameter without rotating the assembly. With long installations using the #36 tubular drive shaft (also on all RV-10D's) the distance from the #33A spool adapter to the bores in the universal joint which is welded to the tubular shaft must be measured on both sides of the joint. Rotate the shaft exactly $1/4$ of a turn and measure to the same joint. The four distances must be equal within $1/8"$. (Do not measure

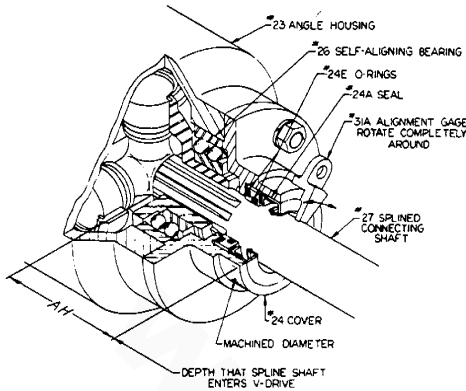

to the joint end that is on the spool adapter. This distance will not vary with misalignment since the joint is bolted and cannot move.) Put the #31A alignment gauge on the machined diameter of the #24 cover and slide it completely around. It will indicate how the engine must be moved to center the spline shaft in the oil seal. Re-measure the joints to see if

they are still parallel within 1/8". It is important that both alignments be checked thoroughly. It is possible for the spline shaft to be perfectly centered and the flexible joint to be out more than 3°. Premature failure of the #26 self-aligning bearing and seals may occur due to misalignment. The zerk fitting (located on the cross of the universal joint) should be greased with a light alemite lubricant. The above procedure should be repeated after the boat has been placed in operation. It is possible for the engine to slightly shift and settle, especially if it has rubber mounts.

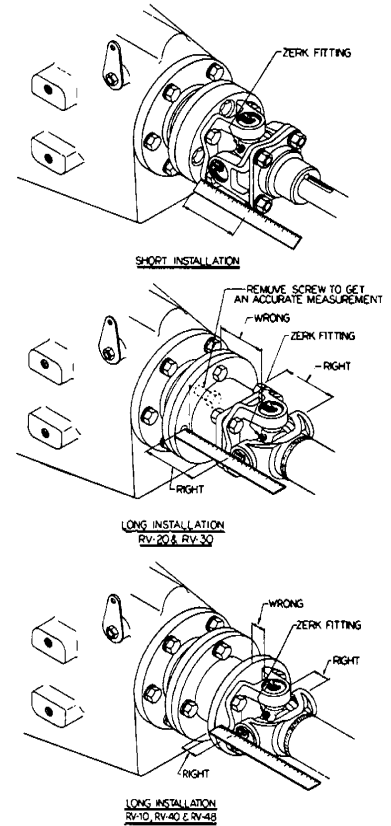

FLANGE ALIGNMENT - INDEPENDENT MODELS

Install the propeller shaft flange on to the propeller shaft and tighten the two clamping bolts on the split hub (none on RV-10). A self-locking set screw is provided for the propeller shaft flange. Spot drill the propeller shaft and securely tighten the set screws.

All V-drives are supplied with 3-way adjustable mounting brackets (2-way on the RV-10 and RV-20) as standard equipment. The brackets must face downward as shown in the illustration to properly absorb propeller thrust. The mounting plates can be removed and reversed to fit wider engine bed centers. Before installing the V-drive, loosen all the nuts on the mounting brackets and check to see that the studs are in the center of the slots. Retighten the nuts. Place the V-drive on the engine bed, lining it up "by eye" to the propeller shaft flange as closely as possible. Firmly bolt it down through the holes provided in the mounting plates. Loosen the locking nuts on the adjusting screws. Slightly loosen the nuts on the mounting brackets just enough to be able to move the V-drive.

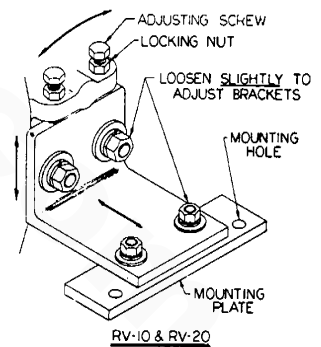

Many good installations are ruined by improper propeller shaft

flange alignment. Accurate alignment will ensure a smooth operating drive train and eliminate many problems that arise due to misalignment. Final alignment should not be attempted until the boat has been allowed to "settle" in the water. Adjust the V-drive until the pilot diameters of the gear shaft flange and the propeller shaft flange engage freely. Butt the flange faces together. Without rotating either flange, check with a feeler gauge in at least four places as shown in the illustration. If the maximum feeler gauge that can slip between the flange faces at any point is .003", the unit is properly aligned. If a thicker gauge can be inserted at any point, the V-drive must be readjusted until proper alignment is obtained. Turn the propeller shaft flange 1/4 of a turn without moving the gear shaft flange. Try inserting the .003" feeler gauge as described above. The gap will not change if the propeller shaft is straight. If it increases, the shaft or flange is bent and must be removed and straightened. Rotate the propeller shaft flange in two more 1/4 turn increments and repeat the procedure. The pilot diameters must be rechecked to ensure that they still engage freely. Tighten the nuts on the mounting brackets and the locking nuts on the adjusting screws. Remove the set screws from the brackets (none on RV-10 or RV-20), spot drill and securely tighten. Recheck the flange alignment to make sure the V-drive did not move out of alignment. Secure the two flanges together with the heat treated bolts and special high collared lock-washers supplied.

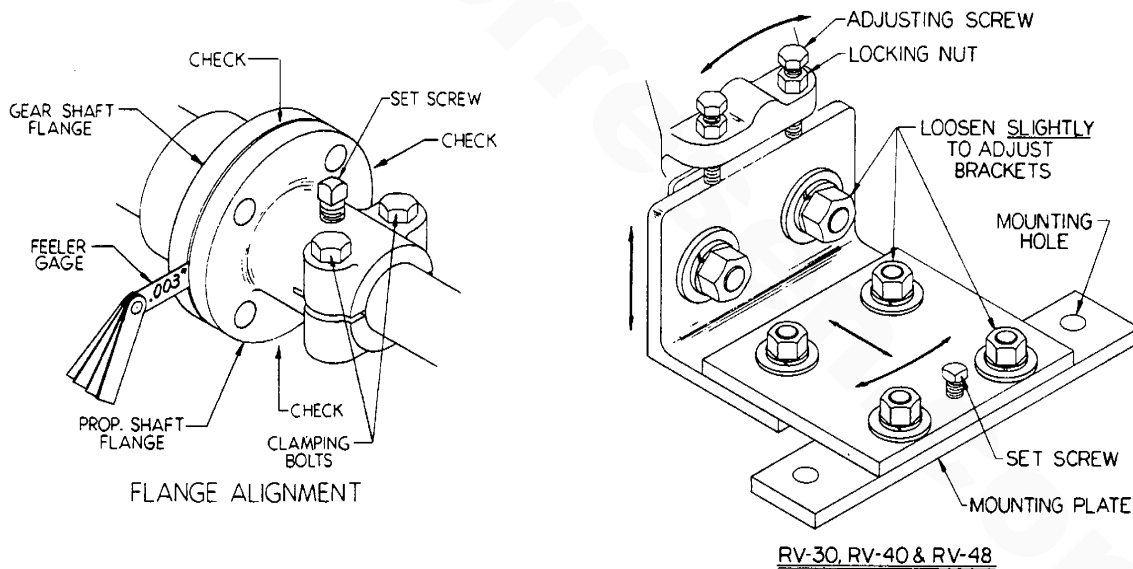

WATER AND SWITCH CONNECTIONS

Hook up the water lines to the two pipe connections on the V-drive (intake and exhaust lines are interchangeable). Generally, one line from the seacock to the V-drive and another from the V-drive to the intake of the engine water circulating pump are utilized. In some cases, scuppers through the hull are connected to and from the V-drive to provide independent water-cooling and are actuated by the movement of the water. With closed cooling systems, the V-drive should be

incorporated into the system between the cooler and the suction side of the water pump. Proper operating temperatures are from 140° to 180°F, although safe operating temperatures may be as high as 210°F. On the models equipped with an oil circulating pump, the #49 oil pressure drop switch and the 12 volt #49A warning light should be hooked up per the wiring diagram. The switch may be grounded to any part of the V-drive or engine (either terminal may be used for the ground).

OIL FILL

Pull out the #21 oil level gauge. Unscrew the #12 breather cap and fill the V-drive with SAE #30 motor oil through the #12A breather elbow. On the RV-10 only, the oil may be added by removing the plug in the #6D top cover. See table below for approximate oil capacities. The amount varies with the angle of installation. The oil level should be checked with the oil level gauge fully inserted in the unit. The proper level is between the "H" and "L" marks on the gauge. Add a 2 ounce tube of Molykote (molybdenum disulfide), which is supplied with each V-drive for extra lubrication and break-in. It provides protection against scoring or galling of gears, bearings and other moving parts.

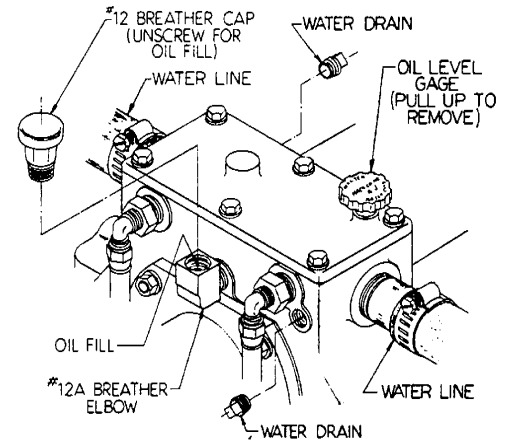

Additional Molykote after break-in is not required. Reinstall the breather cap. The oil level should be rechecked after the unit has been run and allowed to sit for about a minute. Add oil if necessary.

	RV-10	RV-20	RV-30	RV-40	RV-48
Oil capacity (Approx.)	1 pint	2 pints	3 pints	4 pints	4 pints

DEALER PREPARATION

The propeller shaft and engine alignment must be checked and corrected, if necessary, before the boat is delivered. Final alignment should not be attempted until the boat is allowed to "settle" in the water. The oil level must be checked and oil added if required. While the boat is being run, the water connections should be checked for leaks. The oil pressure drop switch and warning light (if the V drive is equipped with an oil circulating pump) should be checked for proper operation. Do not transport the boat with the propeller shaft coupling connected. Damage to the shaft, shaft log and V-drive can result.

OPERATION

A pressure drop warning light is mounted on the instrument panel on V-drives equipped with an oil circulating pump. The warning light will stay on until the boat gets under way and the engine speed increases to sufficient RPM for the pump to maintain pressure. This normally occurs at approximately 1200 RPM, but the actual speed may vary by as much as 400 RPM. Extended cruising at low RPM, such as when trolling, is not harmful to the V-drive, even though the warning light may stay lit. Normal operation is between 6 to 12 PSI. The light will go on when the oil pressure drops below 2 PSI. Loss of oil and/or insufficient oil level are the major causes of pressure drop. The oil level should immediately be restored,

and while running the boat, the unit should be checked for leaks. If the oil level is normal and the light stays lit when the boat reaches normal cruising speed, the wiring should be checked for loose and/or corroded connections. If the wiring is correct and the light remains lit, the #49 pressure drop switch, which is mounted on the side of the V-drive (see illustration), should be checked for proper operation. The switch can easily be removed and an accurate oil pressure gauge installed in its place. If the pressure is normal, the switch should be replaced. If the pressure is below normal, the oil lines should be checked for blockage. The pump should be inspected and replaced if necessary. The pump is standard on the RV-48 and an optional feature on other models (not available on the RV-10).

The oil level should be checked several times during the season, especially on V-drives without pumps (see OIL FILL).

A clatter or rattle in the V-drive at low RPM is due to the overriding of the propeller during the compression stroke of the engine. Although annoying, it is not harmful. It may be reduced by adjusting the idle speed and/or tuning up the engine for smoother operation.

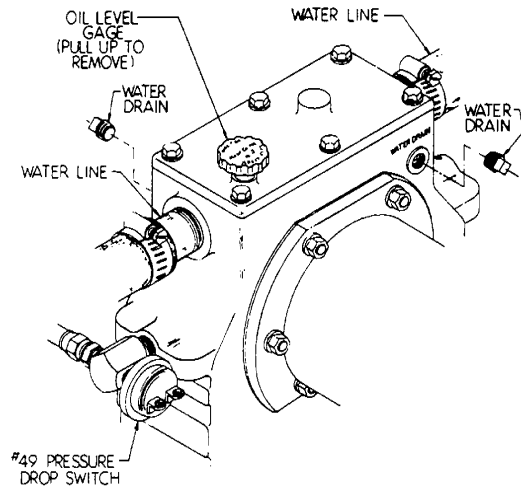

MAINTENANCE

1. OIL CHANGE AND JOINT LUBE

After the first 100 hours of operation and every season and/or 500 hours thereafter, the oil should be changed. Run the boat to warm up the V-drive to operating temperature. Turn off the engine. Remove the plug in the #6B bottom cover that is opposite the #43S oil strainer. Reinstall after draining. Disconnect the oil hose leading from the #43S strainer (leave the elbow on the strainer). Unscrew the strainer and clean the outside surface. Reinstall the strainer and reconnect the oil hose. Unscrew the two #22 magnetic plugs that are located on diagonally opposite corners of the #1C main housing.

The plugs can be checked to see if they are magnetic only after removal. Touch the inside face with a metallic object, such as a screwdriver. Clean them and reinstall. Usually, there are four plugs in the bottom part of the main housing. Only two of these are magnetic. The other two need not be removed (see illustration). Refill with SAE 30 motor oil to the proper level (see INSTALLATION - OIL FILL). The Zerk fitting on the external universal joint should be greased with a light alemite lubricant (see ENGINE ALIGNMENT).

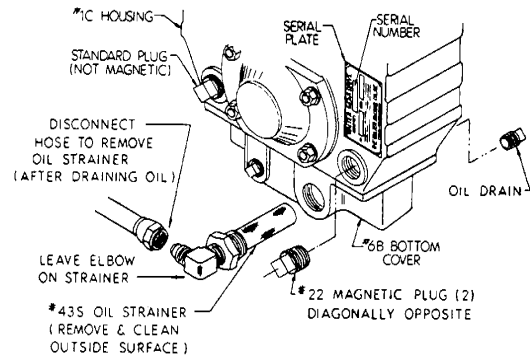

2. WATER DRAIN

For protection from freezing during winter lay-up, remove the small pipe plugs (located diagonally opposite) on the front and back of the housing marked "Water Drain" (see illustration). On the RV-10 only, one of the water lines going into the #6 water-cooled bottom cover must be disconnected to drain the water.

3. FLANGE AND ENGINE REALIGNMENT

When the boat is launched after being in drydock, the line-up of the V-drive to the propeller shaft flange and the engine to the V-drive should be rechecked and corrected if necessary. Some engines with rubber mounts may sag and must be raised with adjustments or shims for proper alignment (see "Flange Alignment" and "Engine Alignment").

GENERATOR SETS

CONTENTS	PAGE
Controls:	
Manual Starter Disconnect (Toggle Switches)...	138
Generator - 25KW.....	144
Generator - 32KW.....	155

MANUAL STARTER DISCONNECT (TOGGLE SWITCHES)

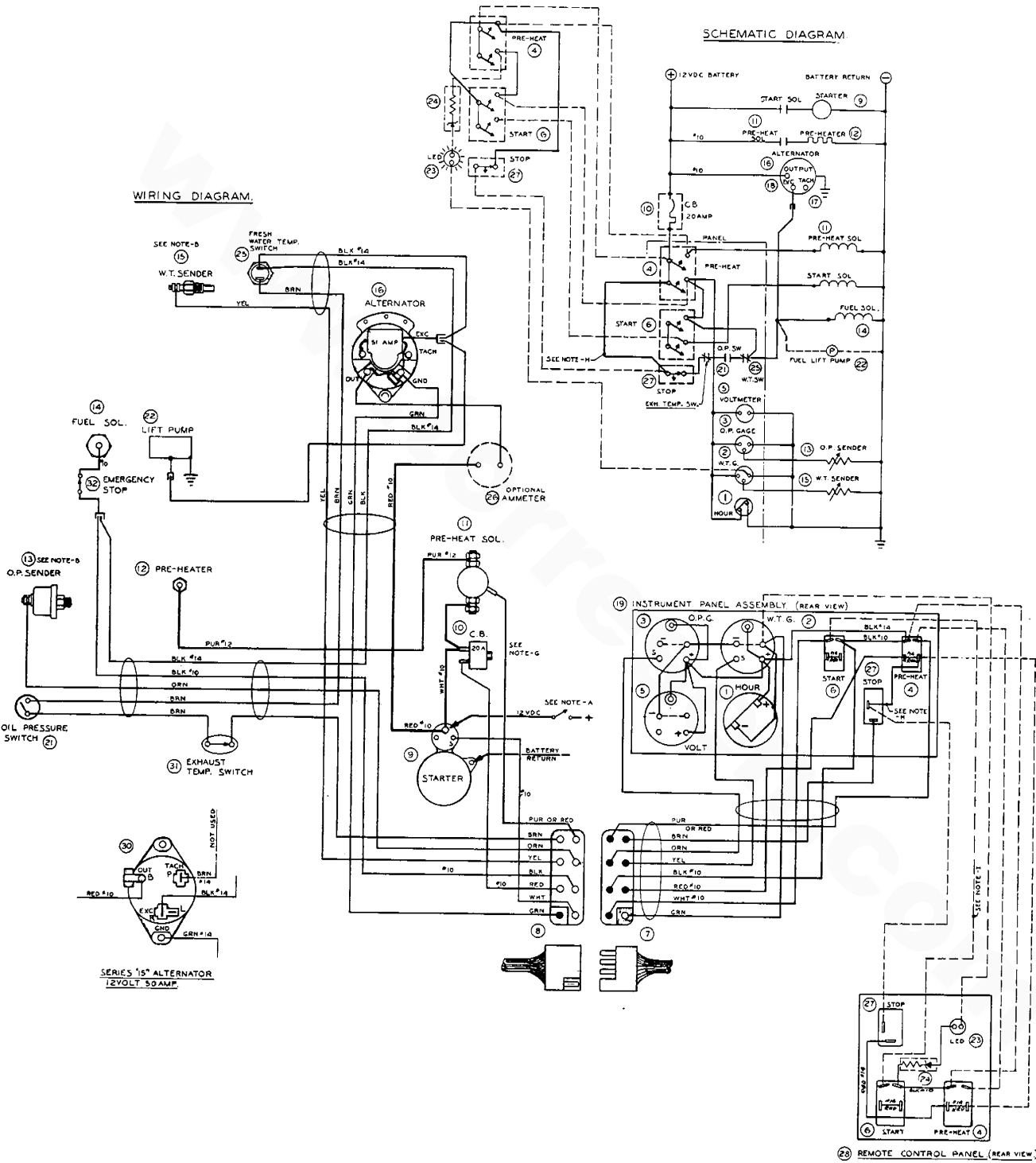

MANUAL STARTER DISCONNECT (TOGGLE SWITCHES)

GENERAL:

This manually controlled series of Westerbeke marine diesel generators is equipped with toggle switches on the engine control panel and, optionally, at remote panels. The following instructions and methods of correcting minor problems apply only to such toggle switch controls.

All three switches are momentary contact type and serve the following functions:

1. Preheat: The PREHEAT/DEFEAT toggle switch is a double pole, single throw switch. The switch serves two purposes: preheating the engine for easy starting and defeating or bypassing the engine protective oil pressure switch. The defeat function turns on the fuel solenoid, instrument power, alternator excitation and provides power to the start switch.
2. Start: The START toggle switch is a double pole, single throw switch. The switch, when activated, energizes the starter solenoid for starting the engine. This switch will not operate electrically unless the preheat switch is also depressed and held.
3. Stop: The STOP toggle switch is a single pole, single throw, normally closed switch. This switch provides power to the fuel solenoid, instrument cluster and alternator excitation, after the oil pressure switch has closed upon starting. Opening of this switch opens the power circuit to the fuel solenoid, thus stopping the flow of fuel to the engine and stopping the engine.

ENGINE OPERATION:

1. Preheat: Depress the PREHEAT switch. The voltmeter, panel lights, gauges and meters and fuel solenoid will activate. The PREHEAT switch should be depressed for twenty seconds in conjunction with thermostarts (installed in intake manifold) and forty to sixty seconds in conjunction with glowplugs.
2. Start: While still depressing the PREHEAT switch, depress the START switch. This will engage the start solenoid. Panel power and the fuel solenoid will be activated. Upon engine firing, release the start switch. Do not release the PREHEAT switch until oil pressure reaches 15 psi. Then as long as the high water temperature and low oil pressure protective circuit does not activate, the set will remain energized and continue to run.
3. Stop: Depress the STOP switch to stop the engine. This opens the power feed to the fuel solenoid, stopping the fuel

flow to the engine. It must be depressed until the generator stops rotating.

REMOTE ENGINE OPERATION:

For remote operation of the generator system, the same three switches are used. The PREHEAT and START switches are connected in parallel with the local panel switches and serve the same functions as in the local panel. The STOP switch is in series with the local panel STOP switch, and serves the same functions as in the local panel. The generator may be stopped from local or remote positions.

AC GENERATORS:

Once the diesel generator sets have been placed in operation, there is little or no control adjustment required by the A.C. Generator. When starting the generator, it is always a good plan to switch off all A.C. loads, especially large motors, until the engine has come up to speed and, in cold climates, starts to warm up. These precautions will prevent damage by unanticipated operation of A.C. machinery and prevent a cold engine from being stalled.

OVERSPEED (If equipped with this option):

If the engine governor loses control and the engine speed accelerates, a relay is actuated that de-energizes the fuel solenoid and stops the engine. A red light on the panel illuminates and remains lighted. To extinguish the light, reset the overspeed relay by depressing the engine STOP switch. When the reason for the overspeed shutdown is corrected, the engine is ready to be restarted.

TROUBLESHOOTING

MANUAL STARTER DISCONNECT (TOGGLE SWITCHES)

CIRCUIT PROTECTION:

The engine control system is protected by a 20 amp manual reset circuit breaker located on the engine as close as possible to the power source. An additional circuit breaker is located at the fuel solenoid (P/N 23041) when this solenoid is used. (This solenoid is not used on models which have a solenoid built into the injection pump.)

Manual Control (toggle switch) troubleshooting.

<u>Problem</u>	<u>Probable Cause</u>	<u>Verification</u>
Preheat depressed, no panel indications, fuel solenoid not energized.	Battery switch or power not on 20 amp circuit breaker tripped	Check switch and/or battery connections. Reset breaker if opens again, check preheat solenoid circuit and "run" circuit for shorts to ground.
Preheat and start depressed, panel indications O.K. Start solenoid O.K. Fuel solenoid not functioning.	Fuel solenoid (P/N 23041) circuit breaker tripped	1. Check mechanical positioning of fuel solenoid for plunger bottoming. 2. Reset breaker and repeat start cycle. 3. If repeated tripping, check for defective breaker or fuel solenoid.
No ignition, cranks, does not start. Fuel solenoid energized.	Faulty fueling system	1. Check for fuel to generator system. 2. Check for air in fuel system (bleed system). 3. Fuel lift pump failure.

Failure to stop.	Fuel solenoid (P/N 23041) return spring	Stop engine by freeing fuel pump lever. That failing, shut off fuel. Check fuel solenoid linkage and repair for free movement.
	Stop switch failure	Disconnect power leads thru stop switch. Test switch for proper oper- by continuity test.
	Fuel injection pump failure	Stop engine with fuel line shut off.
Engine stops.	Low oil pressure or overheated	Check oil, fresh water and sea water cooling.
	Low oil pressure switch fails to close	Check for satisfactory operation with switch bypassed.
	High water tempera- ture switch open at too low a temperature	Same as above.
	Switch and wiring	Inspect all wiring for loose connections and short circuits.
Not charging battery.	Alternator drive	Check drivebelt and its tension. Be sure alter- nator turns freely. Check for loose connec- tions.
	Regulator unit and alternator ("MA" series only)	With engine running, mo- mentarily connect B+ to field. A good alternator will produce a high charge (50 amps). If no response, replace alter- nator. Check for short- ing of alternator output connections to ground.
Battery runs down	Oil pressure switch	Observe if gauges and light are on when engine is not running. Test the normally open oil pressure switch by dis- connecting one lead. If lights go out, replace oil pressure switch.

Battery runs down	High resistance leak to ground	Check wiring. Insert sensitive (0-.25 amp) meter in battery lines. (Do not start engine.) Remove connections and replace until short is located.
	Low resistance leak to ground	Check all wires for temperature rise to locate fault.
	Alternator	Disconnect alternator at output, after a good battery charging. If leakage stops, replace alternator protective diode plate. That failing, replace alternator.

25KW OPERATING INSTRUCTIONS
60 HZ SINGLE BEARING ALTERNATORS
SINGLE AND THREE PHASE

GENERAL

The solid state voltage regulated alternators described herein have been built to give lasting and reliable maintenance free service in their intended application(s) and are SCA certified. Should a situation arise where the alternator fails to operate properly and all mechanical conditions are found to be satisfactory, refer to the electrical section of this manual as an aid in analyzing the cause and effecting a repair.

INSTALLATION

1. The alternator intake and exhaust airways must be kept free of obstructions during operation of the alternator. If the flow of cooling intake air or heated exhaust air is inhibited, eventual alternator overheating and subsequent failure of the alternator to operate may occur.
2. Care should be exercised during the electrical hookup to the alternator output, so as not to damage the voltage regulating circuits found within the control box. See figure 4 for alternator connection diagram.

OPERATION

NOTE:

1. Do not exceed the maximum alternator shaft speed of 2200 RPM as permanent alternator damage may result.
2. If there are unusual noises from the alternator at any time during its operation, shut it down and check for internal mechanical wear and/or damage.
3. For the protection of line frequency sensitive loads that may be connected to the alternator, only operate at an alternator shaft speed of 1800 RPM (60 Hz).

These alternators are classed drip proof. The air intake and outlets are covered with an expanded metal screen to protect against the ingestion of airborne litter. These screens need not be removed for cleaning. DO NOT operate the alternator without these screens in place.

There are no set up adjustments for the alternator. However, if the value of the output voltage is inconsistent with given specific requirements, then it may be adjusted over a narrow $\pm 5\%$ range and will not normally require readjustment.

To adjust the output voltage, remove the cover from the control box and locate the voltage setting control per figure 1. Using an insulated tool, operate this control to obtain the desired output voltage. Right hand rotation of this control increases the output voltage.

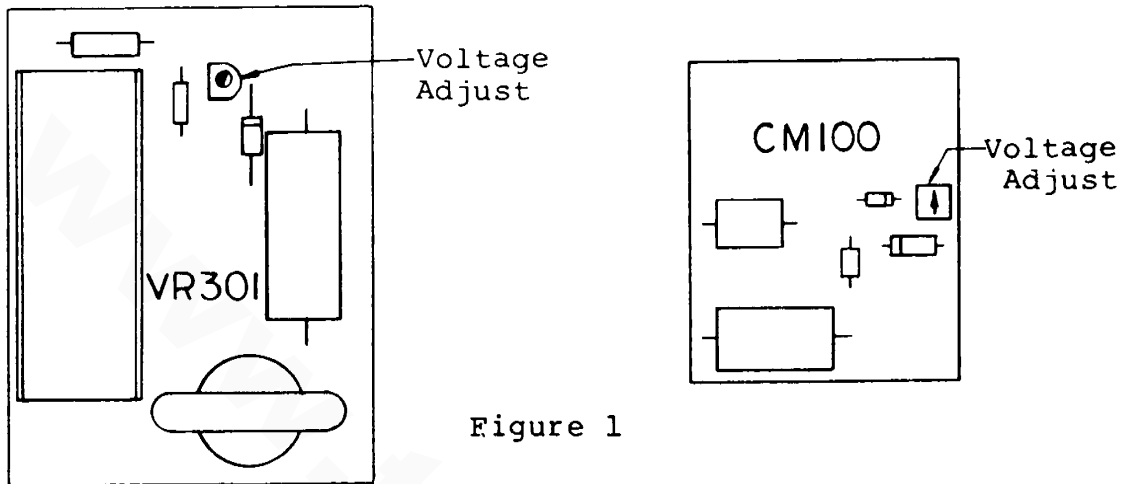

Figure 1

CAUTION

TERMINALS AND COMPONENTS CARRYING LINE VOLTAGE MAY BE EXPOSED WITHIN THE CONTROL BOX AND VOLTAGE REGULATING CIRCUITS WHEN THE ALTERNATOR IS OPERATING. THEREFORE THE USE OF NON-CONDUCTING TOOLS IS ESSENTIAL FOR SAFETY REASONS. ONLY QUALIFIED ELECTRICIANS OR PERSONS THOROUGHLY FAMILIAR WITH ELECTRICAL EQUIPMENT SHOULD ATTEMPT THIS ADJUSTMENT.

PREVENTATIVE MAINTENANCE - MECHANICAL

The alternator is virtually maintenance free and is designed to give 5000 hours of trouble free service. Periodic inspection is suggested to assure the alternator airways do not become obstructed.

CORRECTIVE MAINTENANCE

The alternator can be dismantled from the engine using standard hand tools. See figure 2 for dismantling information.

Some minor repairs and tests can be done without dismantling the alternator. One example is the shaft mounted rectifier. See figure 3 for the checking and/or replacing procedure.

INSTALL RECTIFIER

With heatsink compound (DC #340 or equivalent) tighten to maximum torque of 30 inch pounds.

RECTIFIER ACCESS HOLE.

BEND TERMINAL

To clear alternator housing if required.

RED SPOT

Identifies rectifier output terminal

RECTIFIER OUTPUT LEAD

Only this lead has twin solid magnet wire and tan colored insulation sleeve and will show a low electrical resistance when measured to shaft.

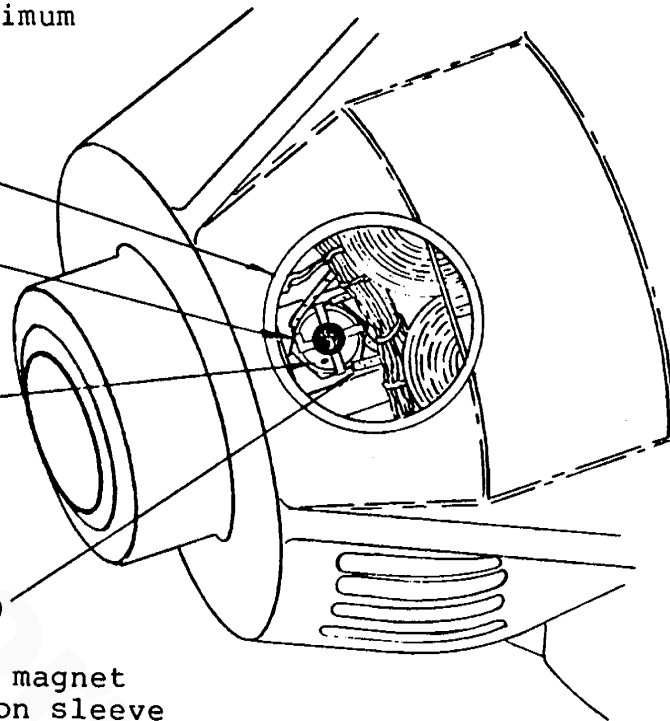

1. Remove the hole cover (item 10) on top anti-drive end of the alternator.
2. Crank engine until the rectifier comes into view and lock to prevent engine from turning the shaft.
3. Unsolder the four wires from the rectifier.
4. Remove the rectifier by unscrewing in counter-clockwise direction then follow testing and replacement procedures described under alternator disassembly above.
5. Replace or reinstall the rectifier reversing the above procedure.

FIGURE 3. BRIDGE RECTIFIER ACCESS

ELECTRICAL FAULT ANALYSIS

An understanding of the alternator's principle of operation may be useful before attempting to analyze an electrical failure; therefore a brief description follows. See figure 4, Schematic Diagram.

The alternator is a brushless, self-excited type requiring only driving force.

One permanent magnet in the six pole exciter stator is responsible for the self-exciting feature of the alternator. Its magnetic field causes a voltage to be induced into the associated exciter rotor coils during rotation. This AC voltage is full wave rectified and applied to the main rotating field coil. The resulting electro-magnetic field induces an alternating voltage into the associated main stator coils and a resulting current will flow to the output terminals.

Simultaneously, an auxiliary coil on the main stator generates an AC voltage which is full wave rectified and employed as a source of supply for the remaining five electro-magnetic poles on the exciter stator. The voltage regulator controls the current flow to these poles, thereby effecting voltage regulation.

FAULT ANALYSIS

<u>SYMPTOM</u>	<u>PROBABLE CAUSE</u>	<u>REPAIR PROCEDURE</u>
1. Mechanical Noise	a) Defective bearing.	Replace bearing.
	b) Worn bearing.	Replace bearing.
	c) Loose or misaligned coupling.	Align and/or tighten.
	d) Foreign objects within.	Remove and check further for possible damage.
2. No Output	a) Short or open circuits in any stator or rotor coil, or associated leads.	Contact Westerbeke if repair is beyond local facilities. Check grounding lead and terminal on shaft behind main rotor coil.
	b) Defective bridge rectifier on shaft (see figure 3).	Replace if faulty and check further for cause.
	c) Faulty voltage regulating circuit.	Repair or replace if faulty and check further for cause.
3. High Output Voltage	a) Misadjusted output voltage control (see figure 1).	Set output voltage to desired value. CAUTION: SOME COMPONENTS CARRY LIVE VOLTAGE AND THE USE OF

INSULATED TOOLS IS
RECOMMENDED.

- b) Wire T2 (120/240V) or T6 (120/208) or T12 (120/208 /416 - 120/240) unground. Clean and/or remake this ground connection.
 - c) Faulty voltage regulating circuit Repair or replace if faulty and check further for cause.
4. Low Output Voltage
- a) Misadjusted output voltage control (see figure 1). Set output voltage to desired value. CAUTION: SOME COMPONENTS CARRY LIVE VOLTAGE AND THE USE OF INSULATED TOOLS IS RECOMMENDED.
 - b) High line loss if voltage is low only at load(s). Increase the size of the wiring leading to the load(s) as required. Load wires should not run hot at continuous full load if properly sized. Do not run a greater length of wire than required as losses increase with distance. If wire is correctly sized and run is not too long, check for poor connections and/or partly broken wires that may be indicated by hot spots in the wire or at terminals of switches, etc.
 - c) Partially shorted main rotor field coil. Contact Westerbeke if repair is beyond local facilities.
 - d) Electrical overload, and/or poor power factor connected to alternator The total load at the prescribed power factor (see identification plate on alternator) should not be exceeded.
 - e) Alternator shaft RPM too low. Check engine speed.
 - f) Faulty voltage regulating circuit. Repair or replace if faulty and check further for cause.

- | | | |
|----------------------------|--|--|
| 5. Unstable Output Voltage | a) Irregular engine speed. | Check engine and loads for transient operation and/or overloads. |
| | b) Loose electrical connections. | Tighten connections as required in load wiring and voltage regulating connector. |
| | c) Faulty voltage regulating circuit or connector | Repair or replace if faulty and check further for cause. |
| | d) Higher than required engine speed. | Check speed is 1800 RPM. |
| 6. Overheating | a) Airways blocked. | Remove obstruction. |
| | b) High ambient temperature. | Do not permit ambient temperature to exceed 40°C (104°F) and operate in a well ventilated and shaded area if necessary. |
| | c) Electrical overload and/or poor power factor connected to alternator. | The total load at the prescribed power factor (see identification plate on alternator) should not be exceeded. |
| | d) Engine exhaust being drawn into alternator air intake. | Redirect engine exhaust as required to prevent this from happening. |
| 7. Alternator Housing Live | a) Static charge. | Properly ground frame of alternator. |
| | b) Open circuit at ground bar in control box. | Ensure alternator neutral has continuity from stator to ground bar. CAUTION: SOME ELEMENTS WITHIN THE CONTROL BOX CARRY LIVE VOLTAGE WHEN ALTERNATOR IS RUNNING. |

RESISTANCE VALUES FOR 25KW SINGLE PHASE GENERATOR

Main Stator	
T1 - T2	0.053
T3 - T4	0.054
Auxiliary Coils	
A1 - A2	0.169
A2 - A3	0.092
A1 - A3	0.091
Exciter Stator	
F1 - F3	2.3
F2 - F4	3.5
Main Rotor*	3.2
Exciter Rotor*	0.56

NOTES

*These values represent measurements taken with leads connected to bridge rectifier. Measurements for main rotor are taken from red dot terminal on rectifier to ground. Exciter measurements can be taken from terminal to terminal. Refer to Figure 3 for rectifier testing.

(1) The above chart is intended for reference use only, as a 10 percent tolerance on these figures is common. Comparison of ratios of actual readings to the above figures is often a more accurate method of troubleshooting.

(2) If any abnormal variations cannot be isolated and symptoms are still evident, contact Westerbeke.

BASIC SCHEMATIC

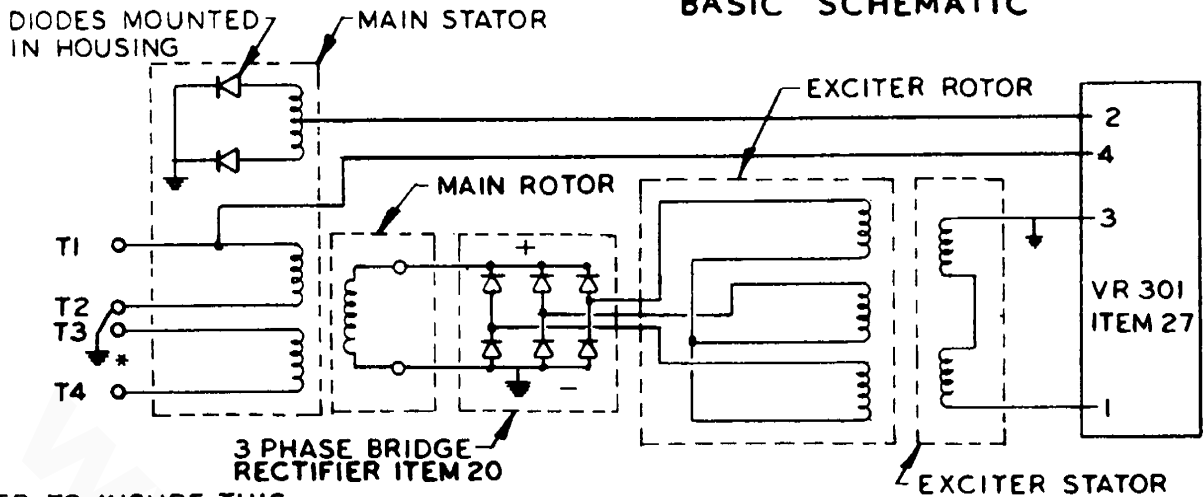

* USER TO INSURE THIS GROUND CONNECTION IS MADE. **SINGLE PHASE (ALL)**

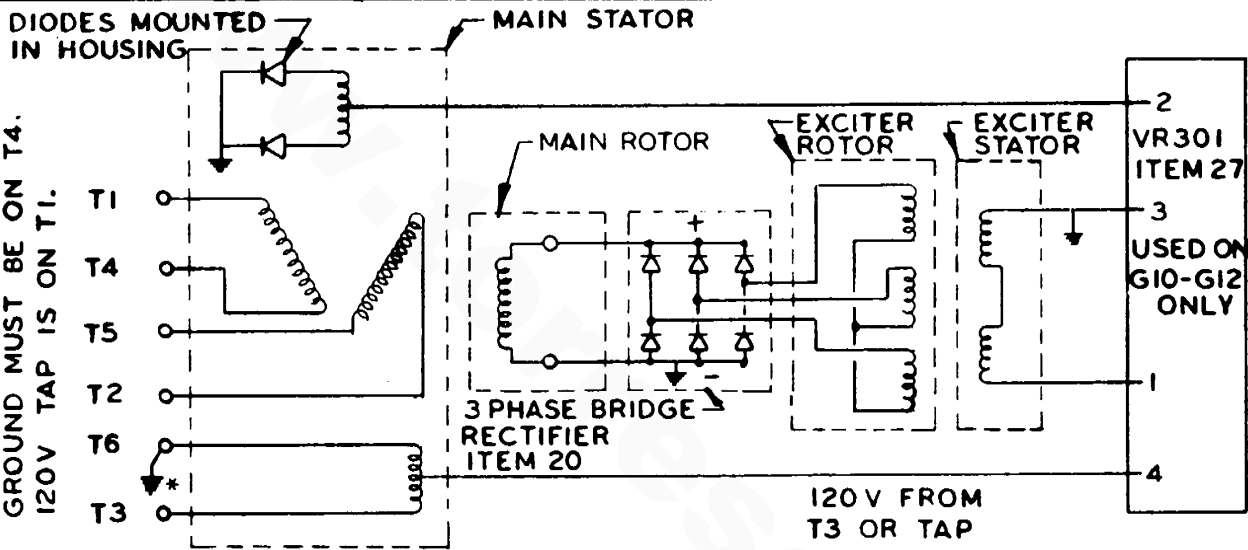

NOTE: 60Hz - 200 UNITS USE CM100 CONTROL MODULE & USER'S GROUND MUST BE ON T4. 120V TAP IS ON T1.

* USER TO ENSURE THIS GROUND CONNECTION IS MADE.

THREE PHASE (TYPICAL 6 WIRE)
EXCEPT -200 SERIES 60 Hz. SEE NOTE

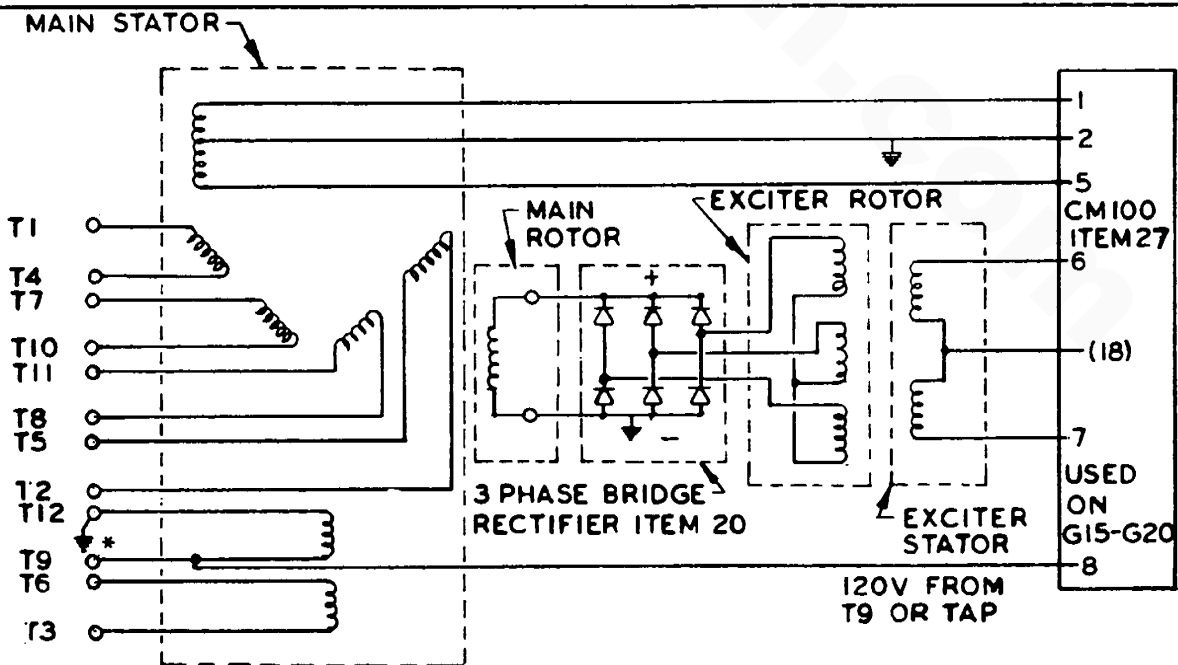

* USER TO ENSURE THIS GROUND CONNECTION IS MADE.

THREE PHASE (TYPICAL 12 WIRE)

Figure 4

ALTERNATOR CONNECTION DIAGRAM

6 WIRE 3 PHASE ALTERNATOR

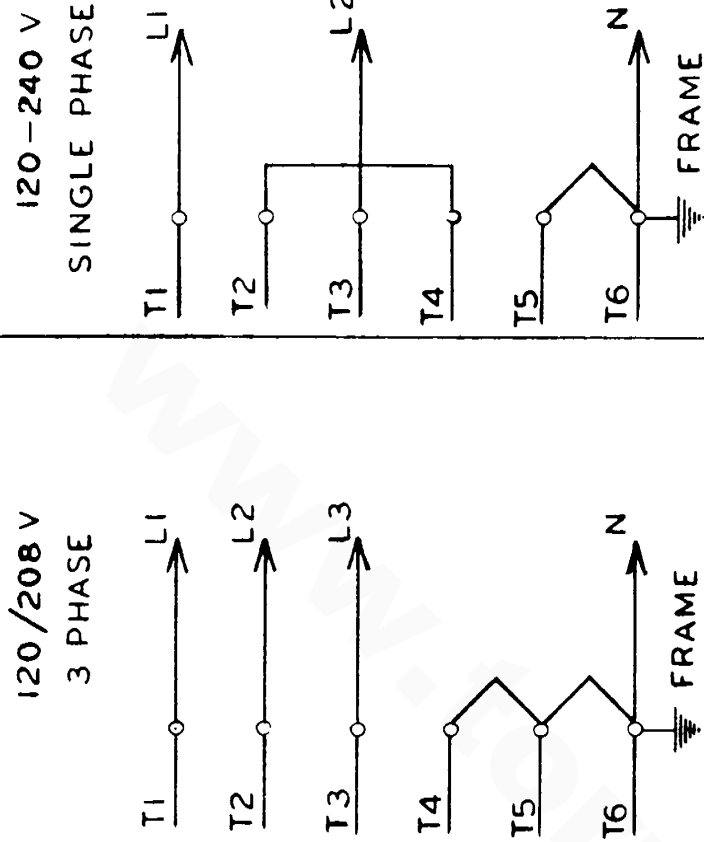

SINGLE PHASE ALTERNATOR

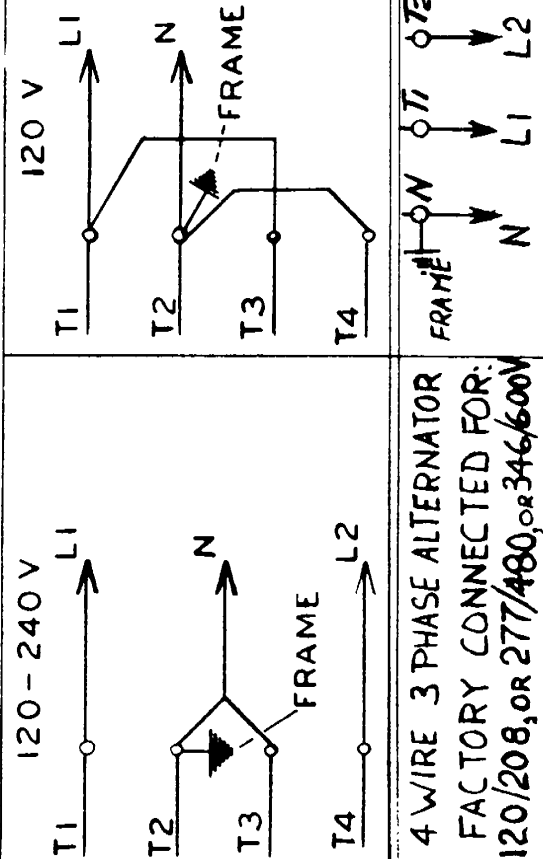

12 WIRE 3 PHASE ALTERNATOR

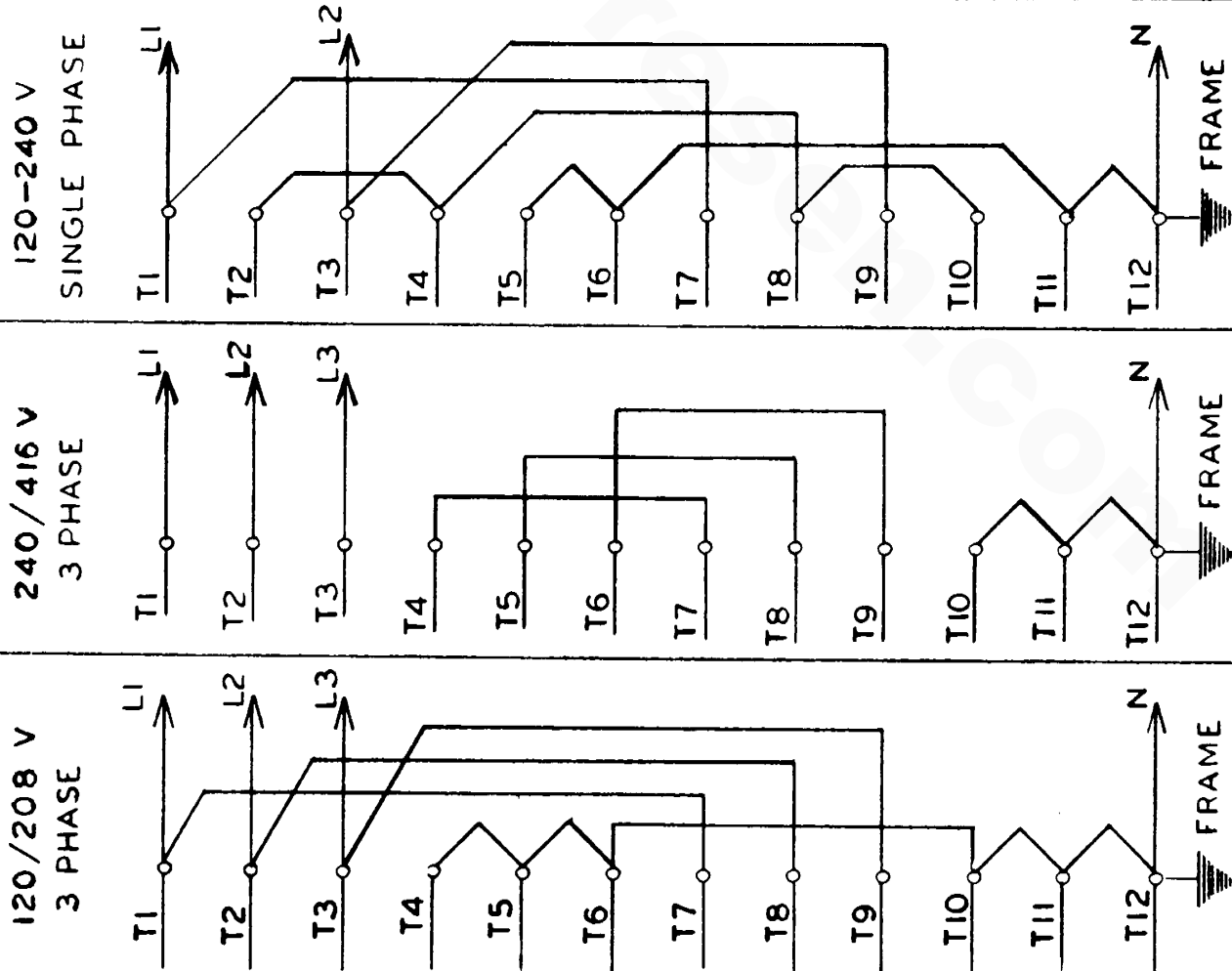

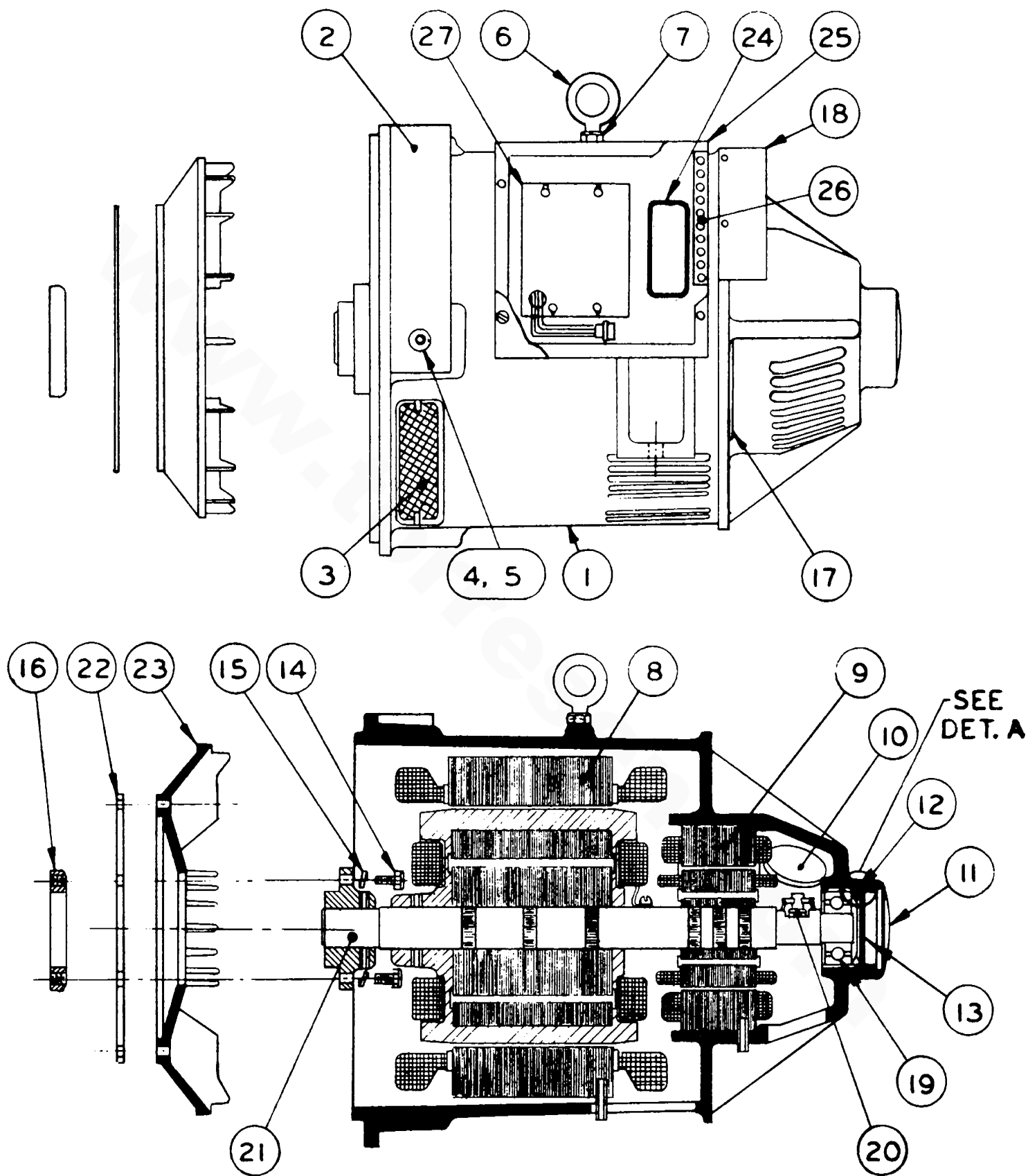
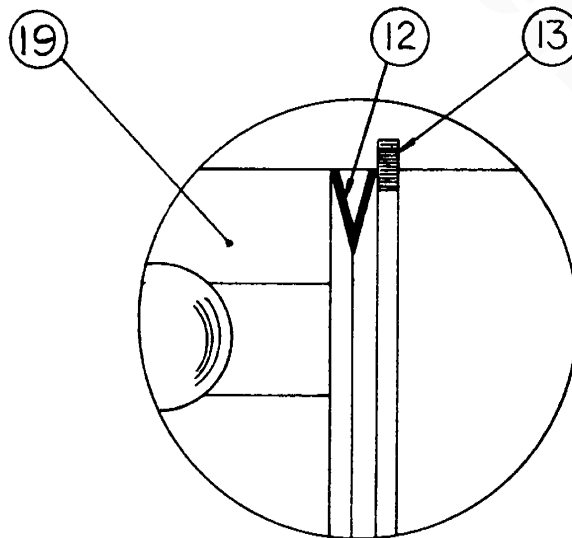

Figure 2

PARTS IDENTIFICATION

- 1 Stator Housing
- 2 Drip Shroud - Exhaust Air
- 3 Exhaust Air Screen (4)
- 4 Helical Lockwasher, 0.25 (3)
- 5 Round Head Screw, 0.25-20 x 0.5" (3)
- 6 Eyebolt
- 7 Nut, 0.375-16 UNC
- 8 Main Stator
- 9 Excitor Stator
- 10 Snap Cover 2.25" Dia.
- 11 Snap Cover 3.00" Dia.
- 12 Belleville Washer
- 13 Retaining Ring
- 14 Cap Screw, 0.312-18 UNC x 1.25" (6)
- 15 Lockwasher Split, 0.313 (6)
- 16 Clamping Ring
- 17 Inlet Air Screen (4)
- 18 Drip Shroud - Inlet Air
- 19 Ball Bearing (Anti-drive End)
- 20 Bridge Rectifier
- 21 Complete Rotor/Shaft Assembly
- 22 Disc Drive (4) or (5)
- 23 Fan
- 24 Continuous Grommet
- 25 Steel Control Box (incl. Cover)
- 26 Neutral (Ground) Terminal Strip
- 27 Voltage Regulator

NOTE: When ordering spare parts, please give reference number, description, model and serial number of both engine and generator.



DETAIL A

30 AND 32KW GENERATORS

DESCRIPTION SUMMARY

Construction type	Rotating Field Brushless, Single Bearing
Speed: 60Hz	1800 RPM
50Hz	1500 RPM
Phase	1 or 3
Ventilation	Self-ventilated (fan cooled)
Ambient Temp., Max.	40°C
Insulation	Class F
Number of poles	4
Stator Leads: 3-phase	4 or 12
1-phase	4 only

PRESTART INSPECTION

1. Check for tightness of all threaded connections.
2. Check load leads for correct connection as specified in diagram.
3. Examine air inlet and outlet for air flow obstructions.
4. Examine generator armature and fan. Are they tight on shaft? Is there clearance around entire circumference of each?
5. Be sure no other generator or utility power is connected to load lines.
6. Be sure that in power systems with a neutral line that the neutral is properly grounded (or ungrounded) as the system requires, and that generator neutral is properly connected to the load neutral. In single phase and some 3-phase systems an incomplete or open neutral can supply the wrong line-to-neutral voltage on unbalanced loads.
7. Make sure mounting is secure.

INITIAL STARTUP

1. After the prestart inspection has been performed, the unit is ready for startup. When driving the generator, observe vibration. If excessive, study possible procedures for correction.
2. The speed of the generator set is adjusted at the factory; however, it is advisable to verify upon installation. To supply 60Hz, the speed should be 1800 to 1860 RPM at no load, and should not fall below 1800 RPM by more than 1 percent at full load. To supply 50Hz, speed should be 1500 to 1550 RPM at no load, and 1500 RPM at full load. Generator voltage should build to its rated value within 5 seconds after rated speed is attained. If

voltage does not build, the cause may be loss of residual magnetism in the exciter field, as a result of generator disassembly and reassembly or some other cause. In such a case (if generator is not defective) voltage build can be achieved by flashing the field as described below. To be assured that a reassembled generator will always build a voltage when placed in service, it should be operated at full rated load before installing in the boat.

3. Record or observe voltage of generator at no load and at full load. Observe voltage immediately after initial startup (cold) and desirably after 30 minutes of operation at full load (hot). The voltages are easily adjusted to optimum values at no load and full load (refer to Regulator section). Voltage is a few volts higher when cold than when hot and reaches equilibrium (hot) after running at full load for 30 minutes. Full load voltage at unity power factor load (incandescent lights and resistor type heating elements) is also a few volts higher than full load voltage with lower power factor loads such as motors, fluorescent lights and mercury lights. If possible, apply actual service load or test load of same power factor as load to be used in service.
4. If voltage cannot be adjusted to suitable values and some fault seems evident, follow the troubleshooting procedure.
5. After running the generator for 30 minutes at full load, observe temperature rise. If smell, touch or temperature measurements indicate excessive temperature rise, examine the generator for obstructed air flow, hot air feeding into cold air inlet of generator or bypassed air (air not pulled through generator) because of air opening into un baffled fan at engine side of generator fan. Also, carefully examine ratings and actual load applied to determine if generator rating may be too low for the load which is applied. Also, be sure ambient temperature is not over 40°C (104°F). FOR OPERATION AT AMBIENT TEMPERATURES ABOVE 40°C, DERATE KW RATING 1 PERCENT FOR EACH °C ABOVE 40°C. FOR OPERATION AT HIGH ALTITUDES ABOVE SEA LEVEL, RATINGS MUST BE DEGRADED 2 PERCENT FOR EACH 1000 FEET ABOVE SEA LEVEL. Frame temperatures above 60°C (140°F) are too high and indicate a temperature rise in the copper windings of 105°C (221°F) or higher.

FLASHING THE FIELD - VOLTAGE REGULATOR 32012

With electronic voltage regulation, a 12 volt battery across F (+) and C (-) behaves as a short across the DC output of the regulator. If the generator is spinning at or near rated speed and the regulator starts to deliver a DC current to the field, the current passing through the battery will be so high that the electronic regulator will probably be damaged. Flash field either by disconnecting F and C from regulator when generator is not turning or flash (while turning) only if rectified diode is in the battery circuit. (See Regulator section or figure below.)

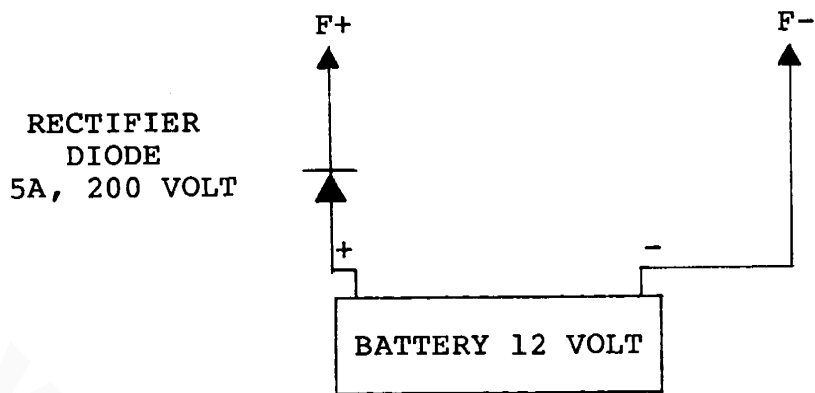

To flash the field while spinning at 1800 RPM, diode must be in + lead of battery as shown here.

MAINTENANCE

1. Maintaining reasonable cleanliness is important. Connections of terminal boards and rectifiers may become corroded, and insulation surfaces may start conducting if salts, dust, engine exhaust, carbon, etc., are allowed to build up. Clogged ventilation openings may cause excessive heating and reduced life of windings.
2. For unusually severe conditions, thin rust-inhibiting petroleum-base coatings should be sprayed or brushed over all surfaces to reduce rusting and corrosion. Typical materials suggested are Ashland "Tectyle 506" and Daubert Chemical Co. "Nox-Rust AC-410".
3. In addition to periodic cleaning, the generator should be inspected for (a) tightness of all connections, (b) evidence of overheated terminals and (c) loose or damaged wires.
4. The drive discs on single bearing generators should be checked periodically if possible for tightness of screws and for any evidence of incipient cracking failure. Discs should not be allowed to become rusty because rust may accelerate cracking. The bolts which fasten the drive disc to the generator shaft must be hardened steel SAE grade 8, identified by 6 radial marks, one at each of the 6 corners of the head.
5. Examine bearings at periodic intervals. No side movement of shaft should be detected when force is applied. If side motion is detectable, bearings are wearing or wear on shaft of bearing socket outside bearing has occurred. Repair must be made quickly or major components will rub and cause major damage to generator.
6. Examine control box at periodic intervals to detect cracks from engine and generator vibration. If cracks in box are seen, engine vibration may be severe and require bracing in box for additional strength to resist vibration.

TROUBLESHOOTING

This section is intended to give helpful hints on finding the cause of any malfunction of the generator, exciter or regulator by doing basic testing and checking. Follow troubleshooting procedures with the aid of the proper generator diagram.

1. VISUAL EXAMINATION

The first step in investigating any generator failure or trouble should be to look for obvious evidence: burned areas, loose or open connections, wrong speed, incorrect reassembly and reconnection, etc.

2. OBSERVE VOLTAGE OF DEFECTIVE GENERATOR

The next step is to carefully measure line-to-line voltage. A voltage at about 10 percent of rated voltage (at rated RPM) is probably the residual voltage (determined by residual magnetism in exciter field). A normal residual voltage indicates exciter armature, rotor and stator are all good and that the trouble is probably in the excitation circuit. A very low voltage, or no voltage, indicates a more serious generator defect (voltage less than 10 volts across a normal 240 volt line).

3. BATTERY EXCITATION

The behavior of the generator, when the exciter field is connected to a 12 volt battery for excitation current, is a useful guide for locating the generator fault. Disconnect F(+) from all other generator connections and connect F(+) to (+) of battery. Connect (-) of battery to C(-). Spin generator at 1800 RPM.

- (a) If residual voltage is normal, 12 volts across the leads F+ and C- should cause the generator to deliver a voltage near rated voltage with no load. If 12 volt excitation produces near normal voltage, failure of voltage regulator to provide voltage could mean a defective voltage regulator, or an open circuit in leads to terminals 3 or 4 of electronic regulator. Check switch or circuit breaker in these leads. With 12 volt excitation connect voltmeter across terminals 3 and 4. Voltage should be the same as generator line-to-line voltage across normal 240 volt lines.
- (b) If 12 volt excitation produces no voltage, check exciter field resistance. It should normally be 24 ohms. If field is open or shorted, then the exciter field is defective. An open or short in the main rotor behaves similarly, but is also accompanied by a very low line-to-line voltage (residual voltage) without 12 volt battery excitation.
- (c) If 12 volt excitation causes the engine to growl and load the engine with no or very low generator output voltage, the stator could be grounded or shorted. Or, a short or ground in the wiring of the generator power circuit could be the main fault. In either case, the stator will develop hot spots or could even smoke after

running a few minutes. Run generator until a hot smell is detected, or stop in 5 minutes (whichever occurs first). Feel the stator winding. If it is hot, the stator or power wiring contains a short circuit. Examine the stator for burned (black) insulation which indicates a defective or damaged stator. Measure stator resistance T1 to T2 and T3 to T4 (half the value listed in 6). Measure stator resistance to ground or hi-pot test at 1500 volts.

- (d) If 12 volt excitation causes an increase in voltage but the output voltage is less than 60 percent of rated voltage, the rectifier (see 4) in the exciter armature could be defective, the exciter armature could be shorted to ground or one phase of the armature winding could have an open circuit. Also, one pole of the main field (rotor) could be shorted or grounded. If any of these defects exist, failure of the electronic regulator will occur. Replacement of regulator alone will be followed by failure of the new regulator. If electronic regulator has failed, it is wise to check exciter current by placing a DC ammeter in the F(+) lead to field. Normal exciter current at no-load rated voltage is 0.65 to 0.95 ampere. A higher current is another indication of a generator defect (described above), which could cause a new voltage regulator to fail.

4. RECTIFIER CHECKING

- (a) Each armature full-wave bridge rectifier has 5 terminals and 6 rectifying junctions. Rectifiers may be readily checked on the low range of an ohmmeter. From the "+" tab to "AC" tab, the ohmmeter should show a high resistance with one polarity of the ohmmeter leads and a low (about half scale deflection) resistance when polarity of the ohmmeter leads is reversed. The same conditions should be found from the "+" tab to any other "AC" tab and from "-" to "AC" tabs. If a zero resistance reading is found, this junction of the rectifier is shorted and the rectifier must be replaced. If a high resistance is found with both polarities of the ohmmeter, this junction of the rectifier is "open" and the rectifier must be replaced.

- (b) Armatures with 3-phase full-wave bridge rectifier

The three phase full-wave rectifier is now standard on most armatures used in generators. This 3-phase (full-wave rectifier) is a single unit with 6 diodes in a special case. The (+) terminal is identified by a red dot on the case and is connected by a short lead to the "+" terminal of armature to which the (+) rotor lead and suppressor lead are connected. The other 3 terminals at the top of the rectifier are AC connections to each of the armature phase leads. The case is the (grounded) (-) lead to the rotor. To test the diodes disconnect the rectifier positive lead at the armature (+) terminal. Test between rectifier (+) lead and any AC terminal. Make the test also between rectifier (-) lead (ground or case) to any AC lead. The tests determine that all diodes are good or that one or more is defective. Since a grounded armature winding gives the same test results as a bad diode, it is

necessary to disconnect all AC rectifier connections and test armature winding for a short to ground before a fault can be positively identified. Also test each diode separately (+) to each AC terminal, and case to each AC terminal to positively identify which diode is bad. (See figure.)

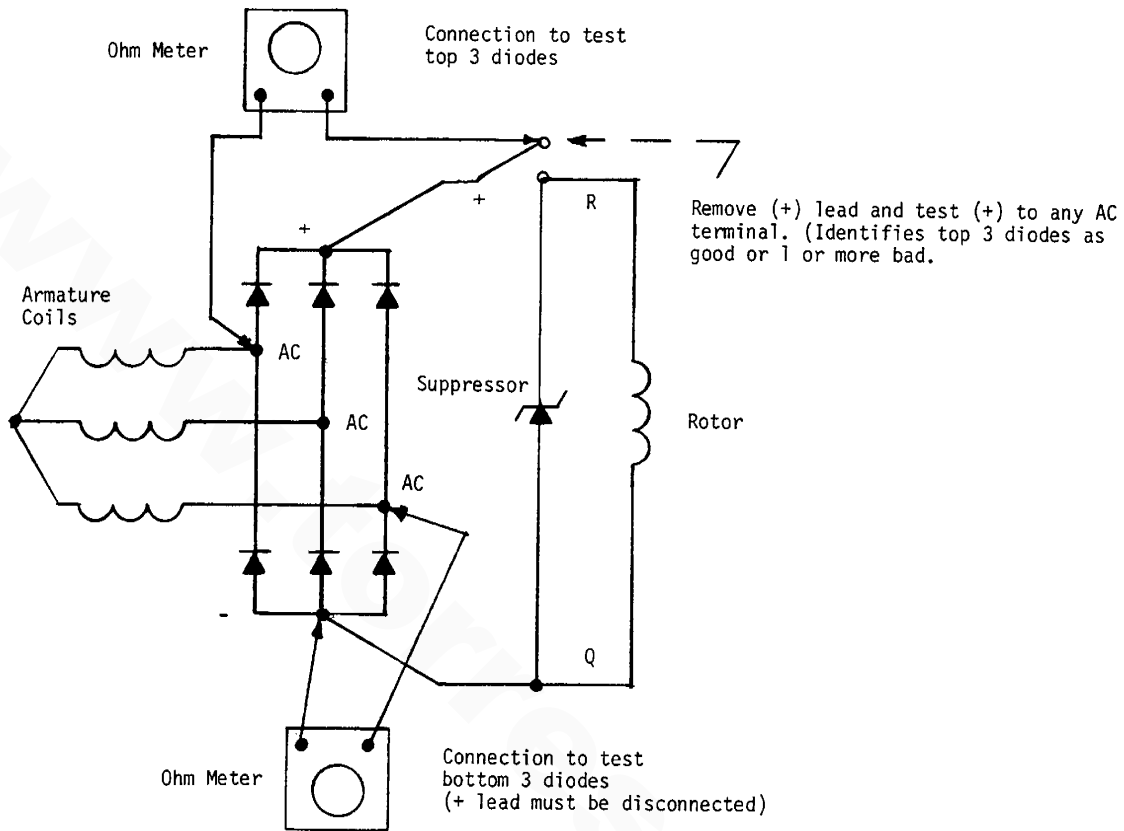

5. VOLTAGE SUPPRESSORS

Voltage suppressors are similar to rectifiers in that they contain in effect a single semiconductor one-way junction. A suppressor should have a high resistance with one polarity of test leads and low but not zero resistance in the opposite direction. Resistance measurements sometimes fail to identify a defective suppressor. The best test is to remove suppressor from circuit. If an obvious improvement in generator is observed, suppressor is bad.

6. RESISTANCE OF WINDINGS

Frequently in troubleshooting a generator, a defective component can be identified by measuring the resistance of a winding.

Resistance values are as follows:

Exciter field F to C	25 to 28 ohms
Armature AC lead to AC lead	.500 to .550 ohms
Stator 30KW 1-PH (T1 to T4)	0.60 to 0.66 ohms
Rotor 30KW 1-PH or 3-PH	2.60 to 2.90 ohms

Exciter field, armature, rotor and stator should withstand 1500 volts between winding and ground with less than 0.002 ampere of current between winding and ground. All electronic components such as rectifiers, suppressors and resistors must be disconnected.

DISASSEMBLY AND ASSEMBLY

To remove the rotating field, it is necessary to remove the end cover by unscrewing the sheet metal screws. Remove the armature fastening bolt at the center of the shaft and detach ground lead "Q" and + lead "R" of the rotor. Mark position of armature so it can be replaced in the same position (armature rotation of 180° is the only other possible position to replace armature). Remove armature from shaft. If a puller is used, pull only on hub. Do not exert excessive force on laminations, since they are soft and easily bent. After armature is removed, rotor and drive disc assembly may be pulled out of generator frame at open end. Do not lose bearing anchor when bearing is removed from exciter end bracket.

As rotor is removed, be careful not to allow rotor to scratch or cut stator copper winding. The rotor and drive disc may now be bolted to engine flywheel.

Make sure the right type lockwasher is used and tighten the bolts (SAE grade 8) well. Locate the bearing anchor and move the generator frame assembly carefully over the rotor. Carefully align the groove in the bearing with the bearing anchor before the bearing enters the bearing bracket. (See figure for clarification.) Fasten the frame assembly to the engine flywheel housing with the proper hardware.

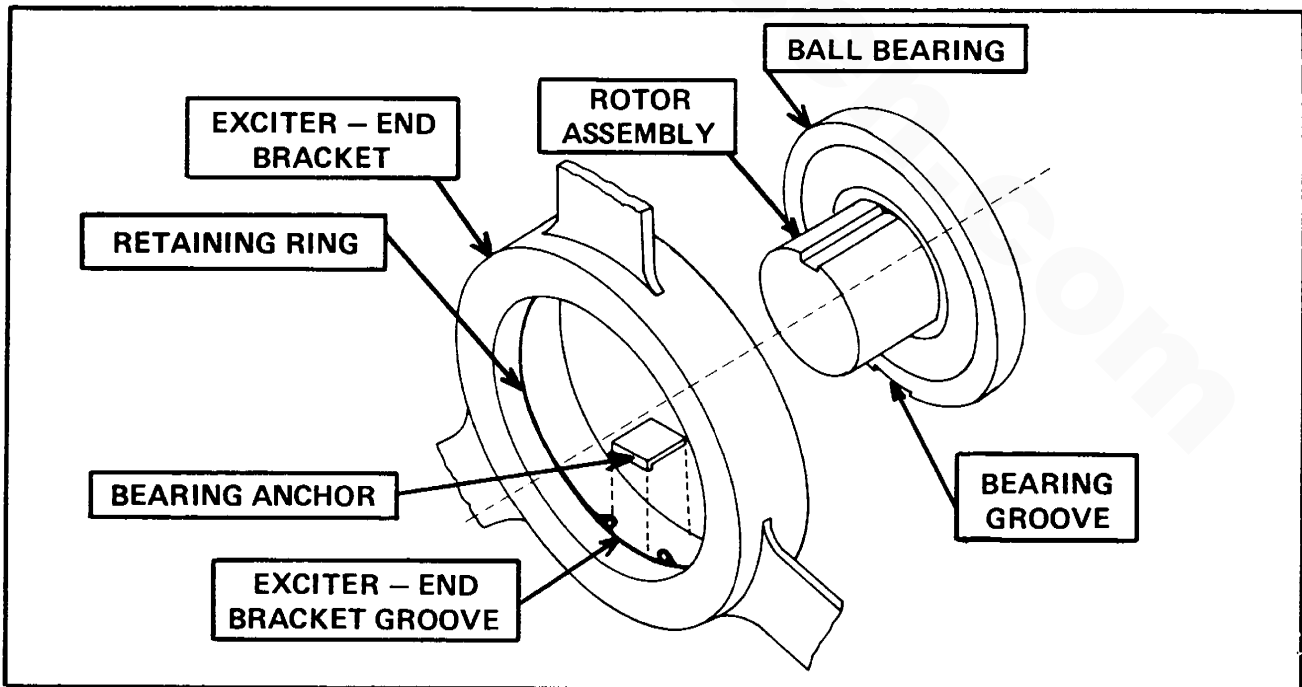

EXCITER - END BRACKET, BEARING AND BEARING ANCHOR ASSEMBLY

With two screws, lockwashers and nuts reassemble the drive-end cover and hood, using a large screwdriver and a 7/16 wrench.

To reassemble the exciter armature, first pull the two rotor leads through the opening in the armature spider nearest the two terminal points. Turn the armature until it slips over the two pins in the shaft, making sure that the rotor leads are not stretched or bent sharply. Assemble the armature to the shaft with the mounting screw and lockwasher using thread-locking compound. Use a 9/16 socket on the torque wrench and torque the mounting screw to 25 lb-ft. Connect the two rotor leads, one to each terminal (polarity is unimportant).

www.torresen.com

GENERATOR & REGULATOR DIAGRAM
 1-PHASE, 4-LEAD, ELECTRONIC REGULATION
 120/240 V & 120 V CONNECTIONS

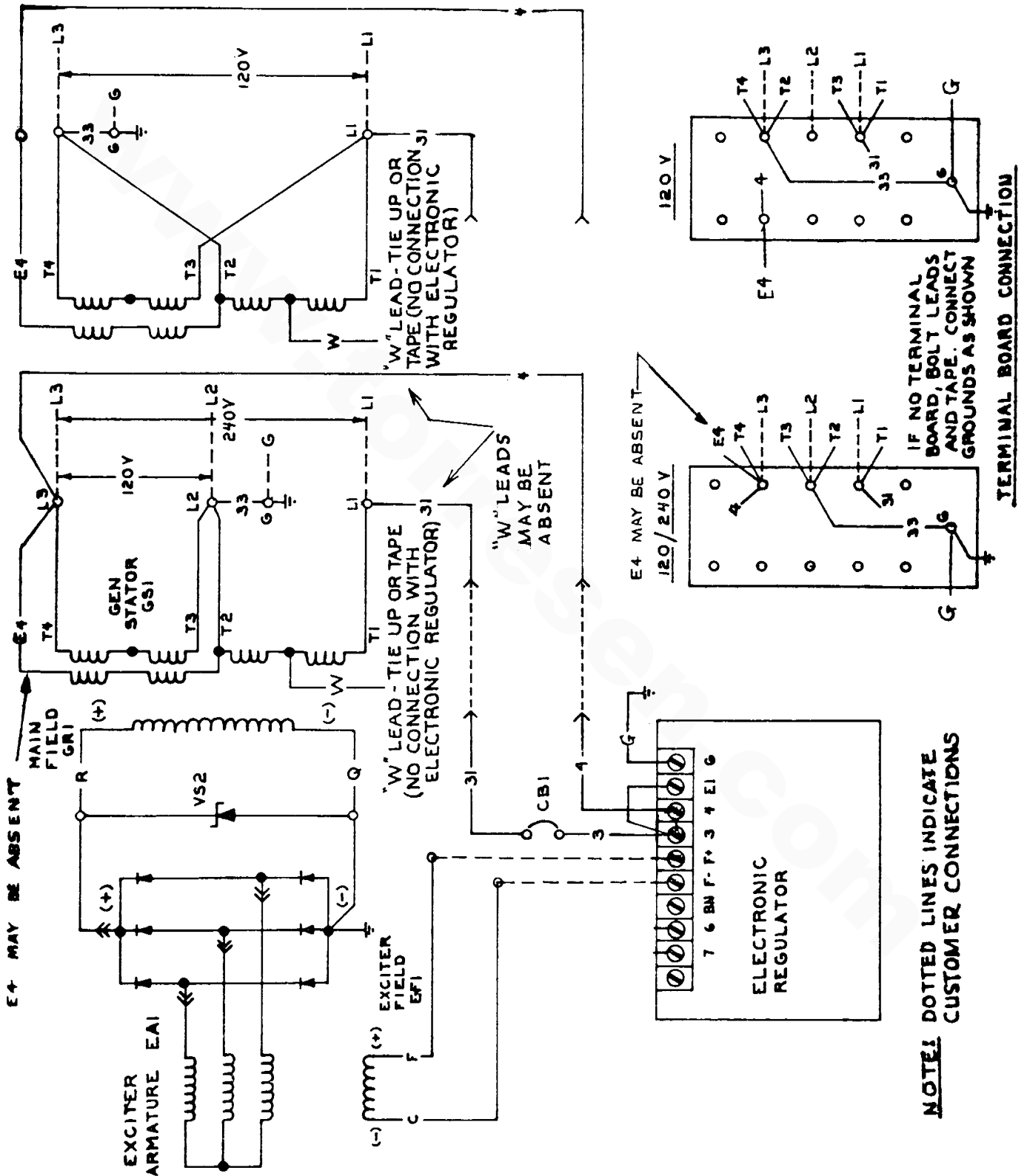

30 AND 32KW VOLTAGE REGULATOR

Electronic regulators hold voltage regulation to within ± 2 percent from no-load to rated full load at rated power factor and rated speed. The electronic regulator #32012 used with the 30 and 32KW generators provides high reliability and good voltage regulation. It provides a constant output voltage at all RPM's.

SPECIFICATIONS

DC Output Power (To Exciter Field)	2.5 ADC @ 63 VDC (160W) Maximum continuous 3.5 ADC @ 90 VDC (315W) Forcing, 1 minute (with 240 VAC input) Exciter field DC resistance - Minimum 25 ohms - Maximum 100 ohms
AC Input Power (From Generator Output)	Operating range 190 VAC - 240 VAC -10% to +10% 1 phase, 50/60 Hz. Refer to the interconnection diagram Figure 1 for operation at other generator voltages.
AC Sensing Voltage	Nominal 190-200-208-240 VAC, 1 phase, 50/60 Hz, -10% to +10%. Refer to the interconnection diagram figure 1 for operation at other generator voltages
	BURDEN: Regulator #32012 - 2.0VA
Voltage Adjust Range	Internal Adjustment from 10% below 190 VAC to 10% above 240 VAC. (External adjustment when provided is $\pm 10\%$ of nominal voltage.)
Regulation Accuracy	Less than $\pm 1\%$ when no load to full load excitation ratio is not more than 5.
Voltage Drift (Temp. Coefficient)	Less than 1% voltage variation for a 50°C (90°F) temperature change.
Response Time	Less than 2 cycles.
EMI Suppression	Standard Internal Electromagnetic Interference (EMI Filter).
Voltage Build Up	Internal provisions for automatic voltage build up from generator residual voltages as low as 5 VAC.
Power Dissipation	20 Watts maximum.
Operating Temperature	-40°C (-40°F) to 60°C (140°F)
Storage Temperature	-65°C (-85°F) to 85°C (185°F)

INSTALLATION

1. MOUNTING

The regulator can be mounted in any position without affecting its operating characteristics. Its rugged construction permits mounting directly on the generator set.

2. SENSING CIRCUIT (TERMINALS E1 AND 4)

The voltage that the regulator senses and regulates is applied between terminals E1 and 4. This sensing voltage must be in the range of 170 through 264 VAC. Typical sensing voltages are 190-208-240.

3. EMI FILTER (TERMINAL GND)

A standard internal Electro-Magnetic Interference filter circuit suppresses noise particularly in the AM radio band. For effective EMI suppression it is important that a good low impedance connection be maintained between the voltage regulator ground terminal and earth ground. On most applications, acceptable EMI reduction is achieved by simply connecting the EMI ground terminal to the regulator mounting bolt.

4. FIELD POWER (TERMINALS F+ AND F-)

The power is supplied to the generator exciter by Terminals F+ and F-.

The DC resistance of the exciter field to which the voltage regulator is connected (terminals F+ and F-) must be between 25 and 100 ohms. If the DC resistance is less, a resistor of sufficient wattage must be added in series with the field. When selecting this resistor, care must be exercised not to exceed the regulator maximum continuous output at full load (not more than 63 VDC).

5. GENERATOR VOLTAGE ADJUSTMENT

An internal control R5 provides adjustment of the generator output voltage. When this control is adjusted as indicated by the arrow on the cover, generator output voltage increases.

OPERATION

1. VOLTAGE SHUTDOWN

The system should be equipped with a double pole switch to allow removal of excitation in an emergency or when the generator prime mover must be operated at reduced speed. When used, this switch must always be installed in the AC input power lines of the regulator (Terminals 3 and 4). A dangerously high flyback voltage could develop if this switch is installed in the field circuit (Terminals F+ and F-).

CAUTION

TO PREVENT POSSIBLE HIGH VOLTAGE ARCING, THE FIELD CIRCUIT MUST NEVER BE OPENED DURING OPERATION. SHUTDOWN CAN BE SAFELY ACCOMPLISHED WITH A VOLTAGE SHUTDOWN SWITCH AS DISCUSSED ABOVE.

2. OPERATION AT REDUCED SPEEDS

Prolonged operation at speeds lower than normal can cause damage to the voltage regulator and/or exciter field. If operation at reduced speed is essential, AC input power should be removed from the regulator.

3. FIELD FLASHING

Field flashing is rarely necessary. However, if required, the machine must be at rest and the regulator terminals 3, 4 and E1 disconnected and a DC source of not more than 48 VDC applied to terminals F+ and F-. The positive terminal of the DC source must be connected to F+ and the negative terminal to F-. Allow approximately 30 seconds before removing the DC source and reconnect terminals 3, 4 and E1 to the voltage regulator. System start-up can be accomplished at this point. If field flashing is required while the machine is rotating, contact Westerbeke for further information.

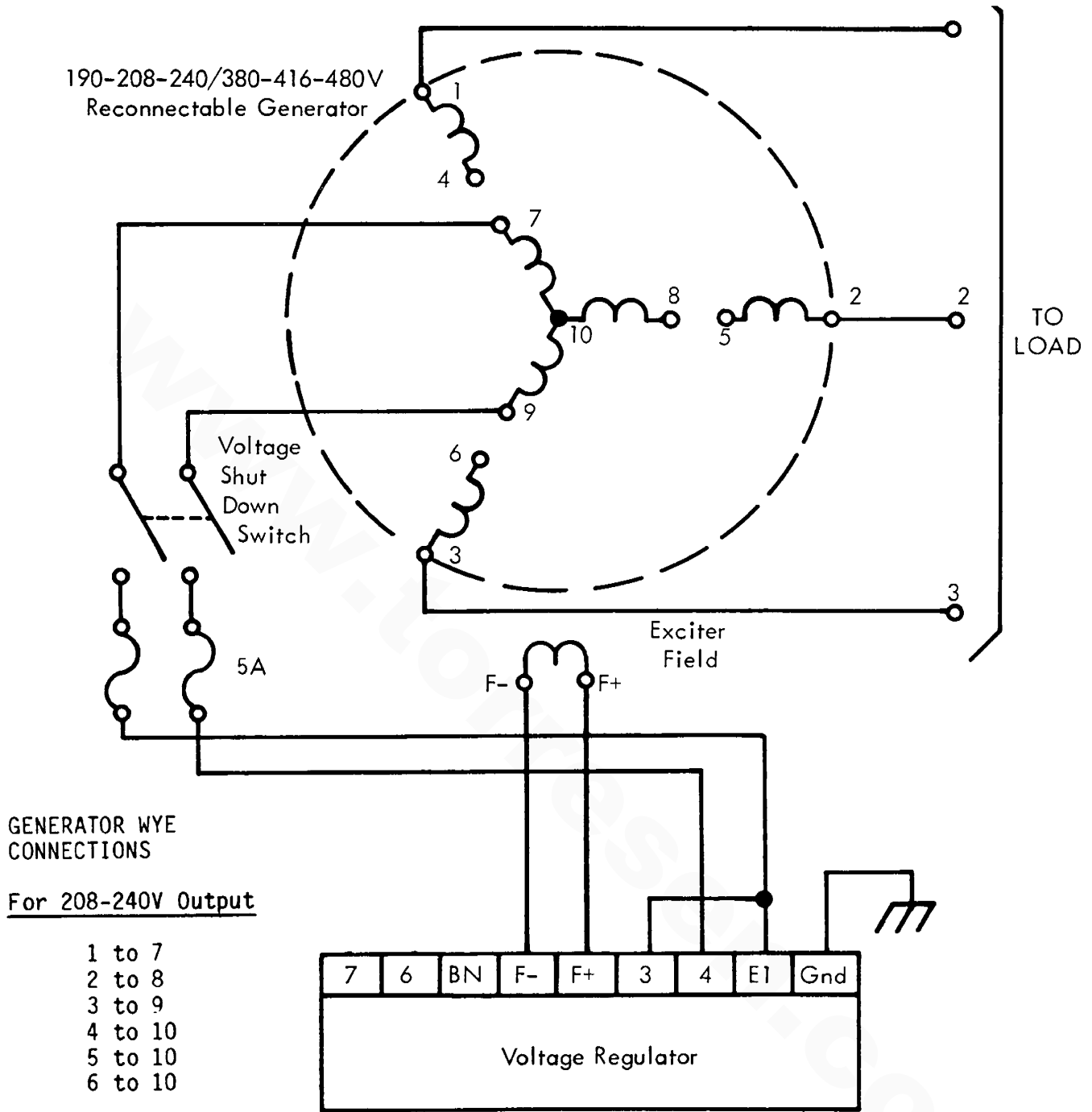

Note: Never connect terminal E1 to terminal 4.

Loss of sensing voltage and maximum generator voltage would result.

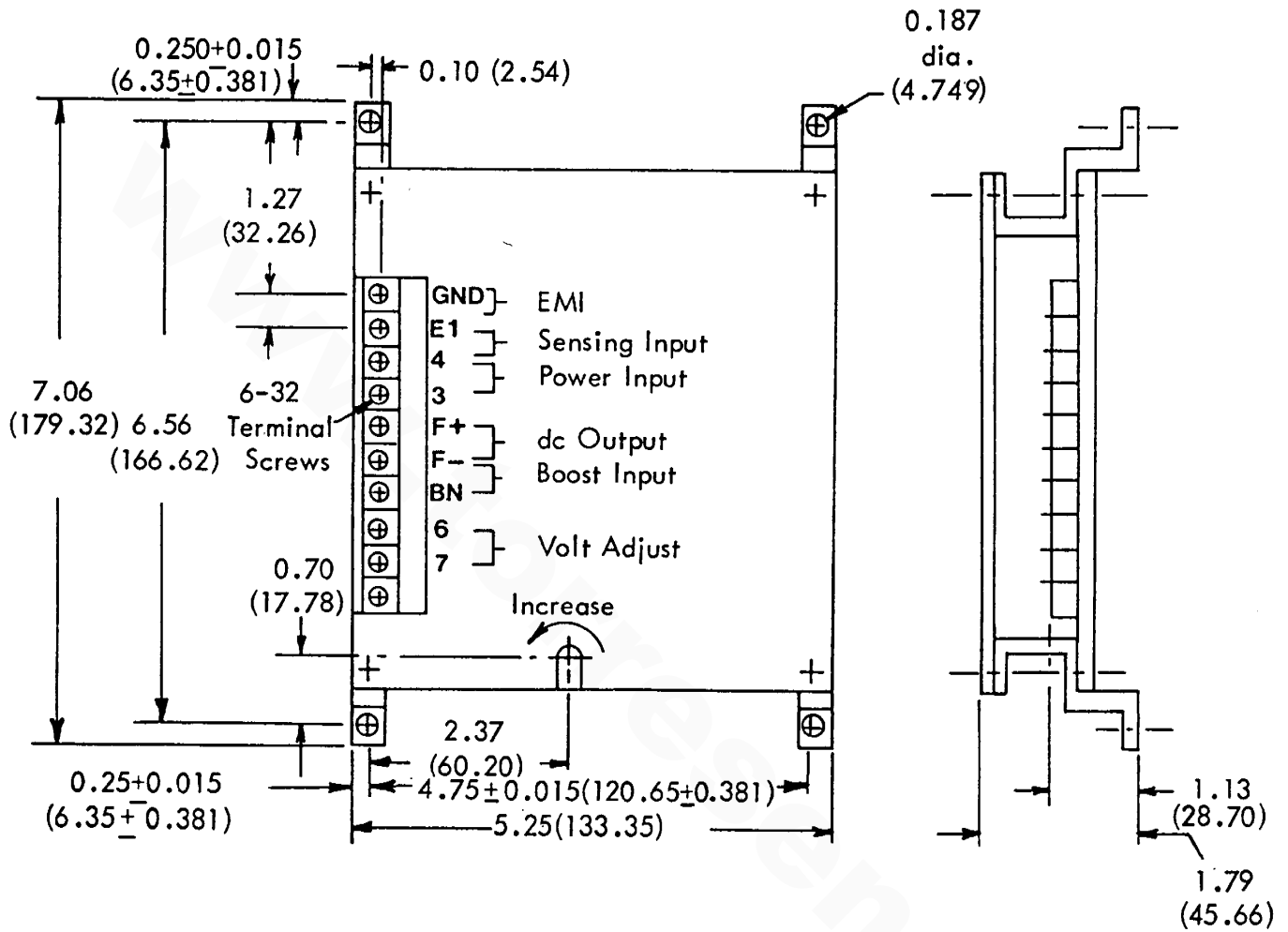

Note: Numbers in parentheses are in millimeters.
Tolerance ± 0.03 (0.762) unless otherwise noted.

Weight: 1 lb. Net (Approximately)

SECTION V

SERVICE BULLETINS

The following Bulletins contain supplementary and updated information about various components and service procedures which are important to the proper functioning of your engine and its support systems.

You should familiarize yourself with the subjects and make sure that you consult the appropriate Bulletin(s) whenever your engine requires service or overhaul.

SERVICE BULLETIN

DATE: 6/15/79

BULLETIN NUMBER: 20

MODEL: All engines

SUBJECT: Connecting Pressure Sensing Devices to Oil Galleries

Oil pressure sensing devices, such as senders and switches, must never be connected directly to any oil gallery of an engine. The reason is simply that continued engine vibration causes fatigue of the fittings used to make such a connection. If these fittings fail, the engine loses its oil pressure and very quickly seizes.

Such pressure sensing devices must be bulkhead mounted and connected to the oil gallery using an appropriate grade of lubricating oil hose. Any fittings used to connect the hose to the gallery must be of steel or malleable iron. Brass must not be used for this purpose.



J. H. WESTERBEKE CORP.

AVON INDUSTRIAL PARK, AVON, MASS. 02322 · (617) 588-7700
CABLE: WESTCORP, AVON · TELEX: 92-4444

SERVICE BULLETIN

DATE: 5/6/74 BULLETIN NUMBER: 69
MODEL: All Marine Generators and Marine Engines
SUBJECT: Exhaust System Failures

When engine sea water is fed into an exhaust system so that the full stream strikes a surface, erosion may cause premature failures.

Proper design of either a water jacketed or a water injected ("wet") exhaust system to prevent this problem requires that the sea water inlet be positioned so that the entering stream of water does not strike a surface directly. Also, the velocity of the entering sea water stream should be as low as possible which is achieved by having inlet fittings as big in diameter as possible.

In addition to the above design considerations, it is usually advantageous to divide the sea water flow at the point of entry to the exhaust system so that only a portion of it enters the exhaust system. The remainder is normally piped directly over the side. The proper proportion of the sea water flow to pass through the exhaust system can only be determined by trial and error. The goal is to prevent excessive exhaust temperatures with the least amount of sea water.



J. H. WESTERBEKE CORP.

AVON INDUSTRIAL PARK, AVON, MASS. 02322 · (617) 588-7700
CABLE: WESTCORP, AVON · TELEX: 92-4444

SERVICE BULLETIN

DATE: 4/4/83

BULLETIN NUMBER: 82

MODEL: All

SUBJECT: Battery Recommendations

MODEL	BATTERY AMPERE HOURS	VOLTAGE
W7, WPD4	60-90	12 V.D.C.
W10Two, 3KW	90-125	12 V.D.C.
W13, 4KW	90-125	12 V.D.C.
W21, 7.7KW	90-125	12 V.D.C.
W27, 11KW	90-125	12 V.D.C.
W33, 12.5KW	90-125	12 V.D.C.
W30	125-150	12 V.D.C.
W40, WPD10-15	125-150	12 V.D.C.
W50	125-150	12 V.D.C.
W52, 15KW	125-150	12 V.D.C.
W58, 20KW	125-150	12 V.D.C.
W60, WBO-20KW	150-170	12 V.D.C.
W70, 25KW	170-200	12 V.D.C.
W80, 30KW	170-200	12 V.D.C.
W100, 32KW	200 minimum	12 V.D.C.
W120, 45KW	200 minimum	12 V.D.C.

The ampere hour range shown is minimum. There is no real maximum.



J. H. WESTERBEKE CORP.

AVON INDUSTRIAL PARK, AVON, MASS. 02322 · (617) 588-7700
CABLE: WESTCORP, AVON · TELEX: 92-4444

SERVICE BULLETIN

DATE: April 4, 1983

BULLETIN NUMBER: 87

MODEL: All Marine Engines

SUBJECT: Alternator Output Splitter

GENERAL DESCRIPTION: The splitter is a solid state device which allows two batteries to be recharged and brought to the same ultimate voltage from a single alternator as large as 120 amp and, at the same time, isolates each battery so that discharging one will have no effect on the other. Charging rates are in proportion to the batteries' voltage (state of discharge). This method precludes the necessity, and even the desirability, of a rotary switch for selecting which battery is to be charged. It also assures that ships services cannot drain the engine starting battery.

INSTALLATION:

1. Mount splitter on a metal surface other than the engine, preferably in an air stream if available. Do not install near engine exhaust system. Install with cooling fins aligned vertically.
2. Be sure to use a wire size appropriate to the output of the associated alternator. In full power systems number 4 wire is recommended from the alternator to the splitter and from the splitter to the batteries.
3. Connect the alternator output terminal to the center splitter terminal.
4. Connect one splitter side terminal to one battery (s).
5. Connect the other splitter side terminal to the other battery (s).
6. When the splitter is installed, both batteries will see a charging voltage 8/10 volts less than usual. This voltage can be regained, if desired, by connecting the regulator wire directly to the alternator output terminal instead of the regulator terminal.

TEST INFORMATION: When the engine is not running, the side splitter terminals should read the voltage of the respective battery. The center splitter should read zero voltage.

With the engine running and alternator charging, the side splitter terminals should read the same voltage which should be the voltage of the regulator or somewhat less. The center splitter terminal should read .82 volts higher than the readings of the side terminals.

Continued.....



J. H. WESTERBEKE CORP.

AVON INDUSTRIAL PARK, AVON, MASS. 02322 · (617) 588-7700
CABLE: WESTCORP, AVON · TELEX: 92-4444

SERVICE BULLETIN #87 (Continued)
(Alternator Output Splitter)

This unit is sealed for maximum life and is not repairable.

BYPASSING SPLITTER: In the event of failure, batteries may be charged directly from alternator by connecting either splitter terminal #1 or #2 to terminal A, bypassing the splitter itself. This should not be done simultaneously for both batteries unless they are, and will remain at, the same voltage (state of charge).

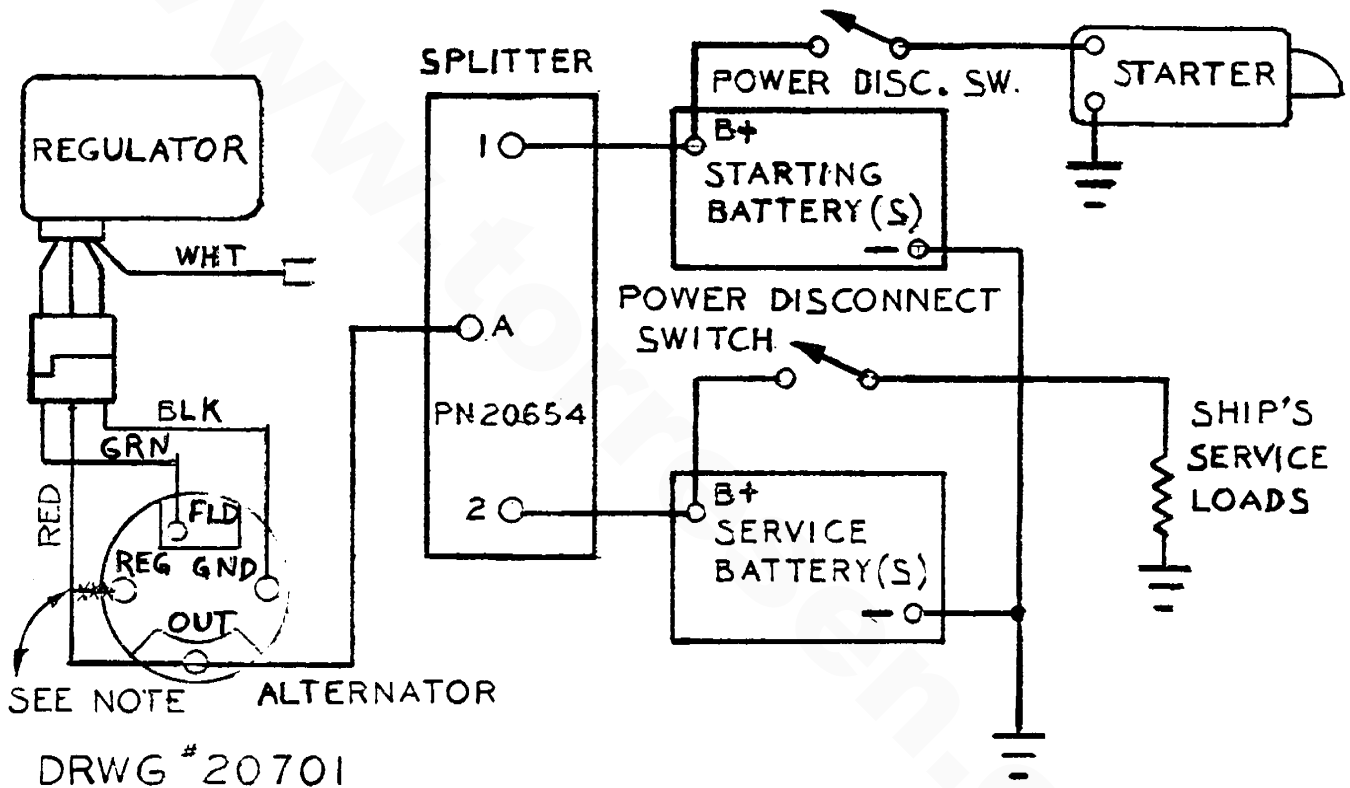

NOTE: On Alternators which have an isolation diode between their output and regulator terminals, such as the Motorola units used with most WESTERBEKE engines, the regulator wire should be removed from the REG terminal and reconnected to the OUTPUT terminal as shown. The diode in the splitter will provide an equivalent voltage drop.

SERVICE BULLETIN

DATE: April 28, 1976

BULLETIN NUMBER: 92

MODEL: All

SUBJECT: Troubleshooting Water Temperature and Oil Pressure Gauges

Given a presumably faulty gauge indication with the instrument panel energized, the first step is to check for 12 VDC between the ign. (B+) and neg. (B-) terminals of the gauge.

Assuming there are 12 volts as required, leave the instrument panel energized and perform the following steps.

1. Disconnect the sender wire at the gauge and see if the gauge reads zero, the normal reading for this situation.
2. Connect the sender terminal at the gauge to ground and see if the gauge reads full scale, the normal reading for this situation.

If both of the above gauge tests are positive, the gauge is undoubtedly O.K. and the problem lies either with the conductor from the sender to the gauge, or with the sender.

If either of the above gauge tests is negative, the gauge is probably defective and should be replaced.

Assuming the gauge is O.K., proceed as follows. Check the conductor from the sender to the sender terminal at the gauge for continuity.

Check that the engine block is connected to ground. Some starters have isolated ground terminals and if the battery is connected to the starter (both plus and minus) the ground side will not necessarily be connected to the block.

If the sender to gauge conductor is O.K. and the engine block is grounded, the sender is probably defective and should be replaced.



J. H. WESTERBEKE CORP.

AVON INDUSTRIAL PARK, AVON, MASS. 02322 · (617) 588-7700
CABLE: WESTCORP, AVON · TELEX: 92-4444

SERVICE BULLETIN

DATE: May 20, 1980

BULLETIN NUMBER: 110

MODEL: All

SUBJECT: Ammeter Wire Sizes

Ammeters may be installed in conjunction with any Westerbeke marine diesel engine or diesel generator set. The range of the ammeter must be appropriate for the maximum output of the alternator.

Additionally, the wire size for the alternator output circuit, including the ammeter, varies with the total length of that circuit. The table below shows the maximum current that can be carried various total distances by various wire sizes, to and from source to load.

WIRE SIZE TABLE

System Volts	Total Length of wire in feet	MAXIMUM CURRENT						
		35	40	55	60	70	85	120
12	1 to 5	12	12	12	8	8	8	6
12	5 to 10	10	10	8	6	6	6	4
12	10 to 20	6	6	6	6	3	3	1
12	20 to 30	6	4	4	2	1	1	1
12	30 to 40	4	2	2	1	1	0	0
24	1 to 5	14	14	12	12	10	10	8
24	5 to 10	12	12	10	10	8	8	6
24	10 to 20	10	8	8	6	6	4	4
24	20 to 30	8	6	6	4	4	4	2
24	30 to 40	6	6	4	4	2	2	0
32	1 to 5	14	14	12	12	10	10	8
32	5 to 10	12	12	10	10	8	8	6
32	10 to 20	10	8	8	6	6	4	4
32	20 to 30	8	6	6	4	4	4	2
32	30 to 40	6	6	4	4	2	2	0



J. H. WESTERBEKE CORP.

AVON INDUSTRIAL PARK, AVON, MASS. 02322 · (617) 588-7700
CABLE: WESTCORP, AVON · TELEX: 92-4444

SERVICE BULLETIN

DATE: May 6, 1982

BULLETIN NUMBER: 114

MODEL: All Marine Engines

SUBJECT: Domestic Water Heater Installation
Using Westerbeke FLOWCONTROLLER

Principle: There are two 7/8" hose connections at the end of the manifold which provide a parallel flow of engine cooling water to and from the heater. These connections are part of the FLOWCONTROLLER which assures a flow of hot water through the heater at all times and yet precludes excessive restriction of engine cooling water flow caused by the heater - all simply and automatically.

Installation: Remove the returnbend which normally connects the 7/8" hose spuds on engines as shipped from the factory. Connect these spuds to the heater with 7/8" ID wire inserted hose. The spud marked "out" indicates the flow from the engine and the spud marked "in" indicates the flow returning to the engine.

Hoses should rise continuously from their low point at the heater and to the engine so that trapped air will rise naturally from the heater to the engine. If trapped air can rise to the heater, then an air bleed petcock must be installed at the higher fitting at the heater for bleeding the air while filling the system. Avoid loops in hose runs which will trap air.

If any portion of the engine cooling water circuit to or from the heater rises above the engine's own pressure cap, then the pressurized remote expansion tank must be installed in the circuit to be the highest point. The tank kit Part Number is 24177. Install the remote expansion tank in a convenient location such as a sail locker for ease of checking fresh water coolant level.

The cap on the engine mounted expansion tank/manifold should not be opened once the system is installed and filled.

The hose connection from the heater to the remote expansion tank should be routed and supported so as to rise continuously from the heater to the tank enabling any air in the system to rise.

FLOWCONTROLLER kits are available for retro-fit to late 1980, 1981 and 1982 Westerbeke marine engines which employ the "two-pass" exhaust manifold. The kit numbers are:

Kit #32276 for engines whose exhaust manifold is on the left side of the cylinder head (W21, RD60, W27, RD80, W33).

Kit #32274 for W13 and Kit #32275 for W52 and W58 engines whose exhaust manifold is on the right side of the cylinder head.



J. H. WESTERBEKE CORP.

AVON INDUSTRIAL PARK, AVON, MASS. 02322 (617) 588-7700
CABLE: WESTCORP, AVON - TELEX: 92-4444

HEATER BELOW ENGINE

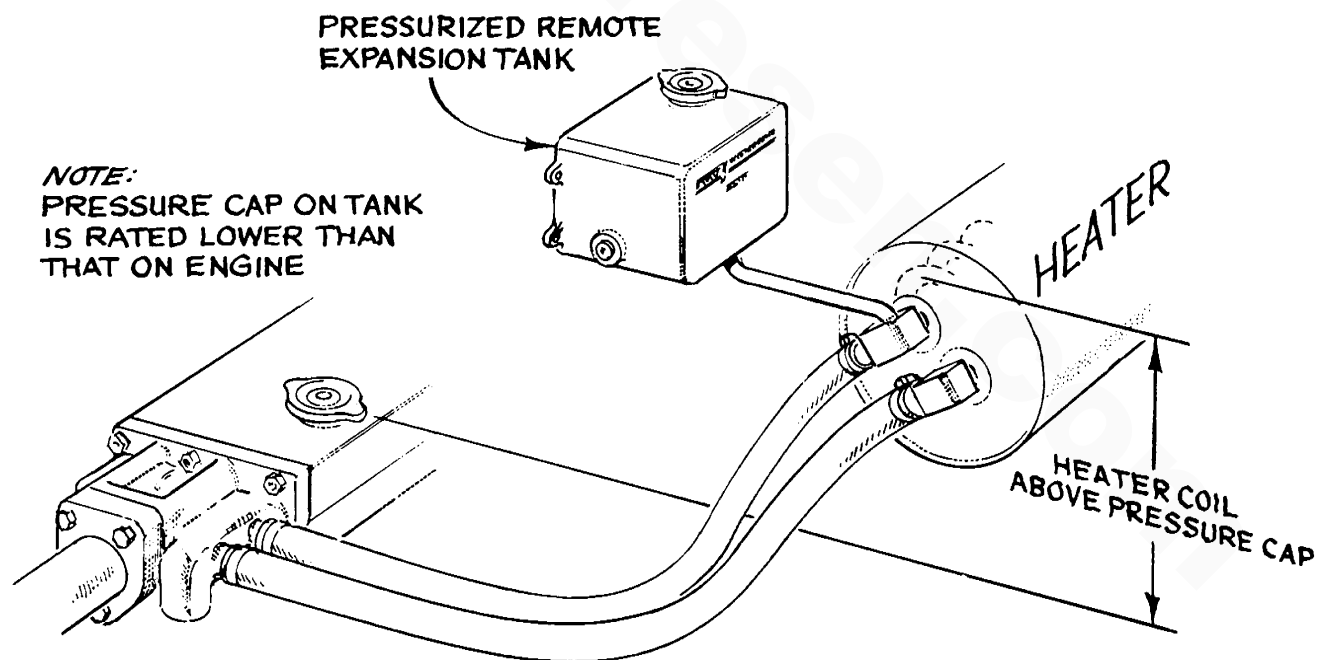
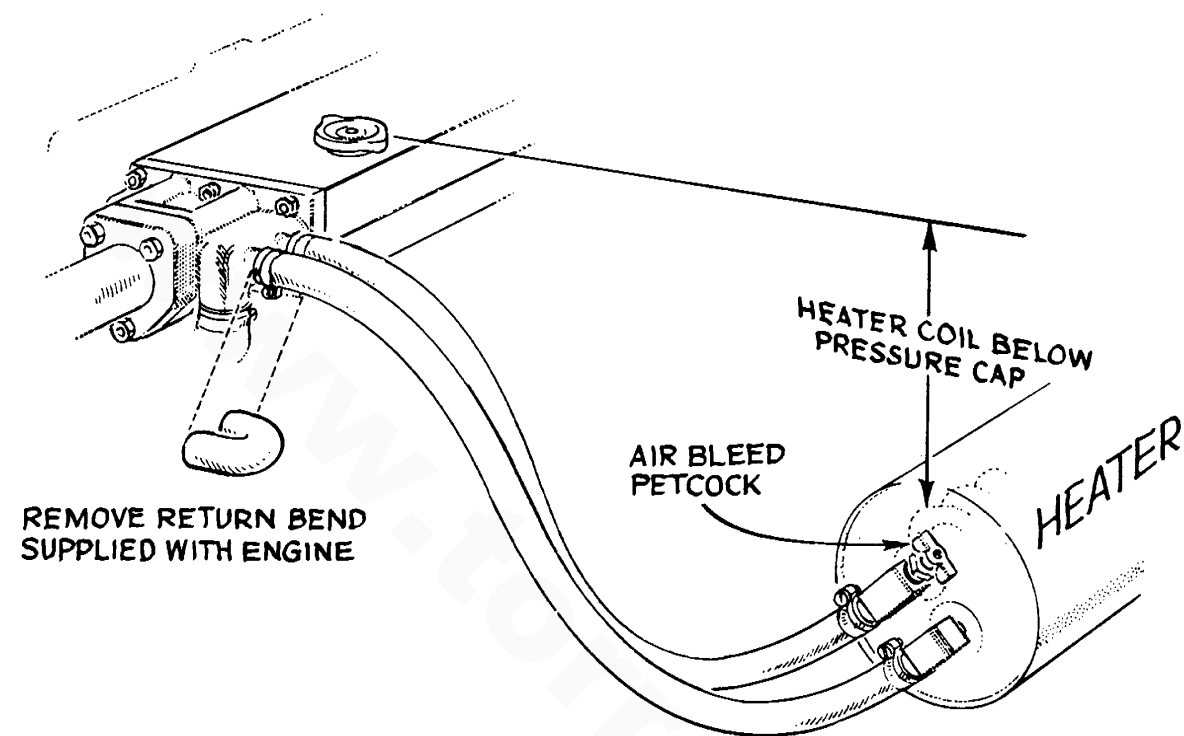

HEATER ABOVE ENGINE

www.torresen.com