

TECHNICAL MANUAL

WESTERBEKE

8.5, 12.5 AND 15.0KW BTG - 60 HERTZ

6.8, 10.0 AND 12.0KW BTG - 50 HERTZ

MARINE GASOLINE GENERATOR SETS

PUBLICATION #037375

EDITION TWO

NOVEMBER 1993



SAFETY PRECAUTIONS

The following symbols appear in this manual to call attention to and emphasize conditions potentially dangerous to the operator.

WARNING

The above symbol is used in the manual to warn of possible serious personal injury or loss of life.

CAUTION

The above symbol is used in the manual to caution personnel of possible damage to equipment.

Read the manual carefully and thoroughly before attempting to operate the equipment. Know when dangerous conditions can exist and take necessary precautions to protect personnel and equipment.

Fuels, exhaust gases, batteries, electrical equipment, and moving and hot parts are potential hazards that could result in serious personal injury or death. Follow recommended procedures carefully.

Always operate bilge blowers for at least five minutes before starting a gasoline-fueled engine; ensure no gasoline fumes are present before starting.

● Prevent Electric Shock

Shut off electric power before accessing electrical equipment.

Use insulated mats whenever working on electrical equipment.

Make sure your clothing is dry, not damp (particularly shoes), and keep your skin surfaces dry when handling electrical equipment.

Remove wristwatch and jewelry when working on electrical equipment.

Do not connect utility shore power to vessel's AC circuits, except through a ship-to-shore double-throw transfer switch. Damage to vessel's AC generator may result if this is not done.

Be extremely careful when working on electrical components. High voltage can cause injury or death.

● Exhaust Gases Are Toxic

Ensure that the exhaust system is adequate to expel gases discharged from the engine. Check exhaust system regularly for leaks and make sure the exhaust manifolds are securely attached and no warping exists.

Be sure the unit and its surroundings are well-ventilated.

● Use Extreme Care When Handling Engine Fuel (A constant danger of explosion or fire exists)

Do not fill fuel tank(s) while the engine is running.

Do not smoke or use an open flame near the engine or the fuel tank.

● Do Not Alter or Modify the Fuel System

Be sure all fuel supplies have a positive shut-off valve.

Be certain fuel line fittings are adequately tightened and free of leaks.

Make sure a fire extinguisher is installed nearby and is properly maintained. Be familiar with its proper use. Extinguishers rated ABC by the NFPA are appropriate for all applications encountered in this environment.

● Use Extreme Care When Servicing Batteries

Wear rubber gloves, a rubber apron, and eye protection when servicing batteries.

Lead acid batteries emit hydrogen, a highly-explosive gas, which can be ignited by electrical arcing or by a lighted cigarette, cigar, or pipe. Do not smoke or allow an open flame near the battery being serviced. Shut off all electrical equipment in the vicinity to prevent electrical arcing during servicing.

● Avoid Moving Parts

Do not service the unit while the unit is running; if a situation arises in which it is absolutely necessary to make operating adjustments, use extreme care to avoid moving parts and hot exhaust system components.

Do not wear loose clothing or jewelry when servicing equipment; avoid wearing loose jackets, shirts or sleeves, rings, necklaces, or bracelets that might be caught in moving parts.

Make sure all attaching hardware is properly tightened. Keep protective shields and guards in their respective place at all times.

Do not check fluid levels or the drive-belt's tension while the unit is operating.

Do not work on the equipment when mentally or physically incapacitated by fatigue.

IMPORTANT

PRODUCT SOFTWARE DISCLAIMER

Product software of all kinds, such as brochures, drawings, technical data, operator's and workshop manuals, parts lists and parts price lists, and other information, instructions and specifications provided from sources other than Westerbeke, is not within Westerbeke's control and; accordingly, is provided to Westerbeke customers only as a courtesy and service. **Westerbeke cannot be responsible for the content of such software, makes no warranties or representations with respect thereto, including the accuracy, timeliness or completeness thereof, and will in no event be liable for any type of damages or injury incurred in connection with, or arising out of, the furnishing or use of such software.**

For example, components and subassemblies incorporated in Westerbeke's products and supplied by others (such as engine blocks, fuel systems and components, transmissions, electrical components, pumps and other products) are generally supported by their manufacturers with their own software, and Westerbeke must depend on such software for the design of Westerbeke's own product software. Such software may be outdated and no longer accurate. Routine changes made by Westerbeke's suppliers, of which Westerbeke rarely has notice in advance, are frequently not reflected in the supplier's software until after such changes take place.

Westerbeke customers should also keep in mind the time span between printings of Westerbeke product software and the unavoidable existence of earlier, non-current, Westerbeke software editions in the field. Additionally, most Westerbeke products include customer-requested special features that frequently do not include complete documentation.

In summation, product software provided with Westerbeke products, whether from Westerbeke or other suppliers, must not and cannot be relied upon exclusively as the definitive authority on the respective product. It not only makes good sense but is imperative that appropriate representatives of Westerbeke or the supplier in question be consulted to determine the accuracy and currency of the product software being consulted by the customer.

TABLE OF CONTENTS

Section	page
PRODUCT SOFTWARE DISCLAIMER	1
TABLE OF CONTENTS	2
MODEL PHOTOS WITH CALLOUTS	4
GENERAL	8
8.5 KW BTG, 12.5 KW BTG AND 15.0 KW BTG ENGINE SERVICE SPECIFICATIONS	9
ENGINE TUNE-UP SPECIFICATIONS	18
AC GENERATOR SPECIFICATIONS	19
TIGHTENING TORQUES REQUIREMENTS	20
TABLE OF STANDARD HARDWARE TIGHTENING TORQUES	21
GENERATOR OVERHAUL	23
PREPARATIONS	24
DISASSEMBLY FOR OVERHAUL	25
ENGINE DISASSEMBLY	27
ENGINE BLOCK DISASSEMBLY	28
ENGINE INSPECTION AND REPAIR	31
ENGINE ASSEMBLY	43
LUBRICATION SYSTEM	57
COOLING SYSTEM	60
GOVERNOR	68
CARBURETOR AND FUEL SYSTEM	70

DC ELECTRICAL SYSTEM	91
8.5 KW BTG, 12.5 KW BTG, AND 15.0 KW BTG DC WIRING DIAGRAM #37190	92
OPTIONAL REMOTE START PANEL WIRING DIAGRAM #35706	94
OPTIONAL REMOTE INSTRUMENT PANEL WIRING DIAGRAM #35698	95
REMOTE PANEL INSTALLATION	99
GENERATOR DESCRIPTION AND MODEL RATING	100
LAY-UP AND RECOMMISSIONING	101
FIELD FABRICATED TOOLS	104
TROUBLESHOOTING THE BT GENERATOR	109
BT GENERATOR 12 & 6 TERMINAL BLOCK AC VOLTAGE CONNECTIONS	126

8.5 KW BTG Marine Gasoline Generator

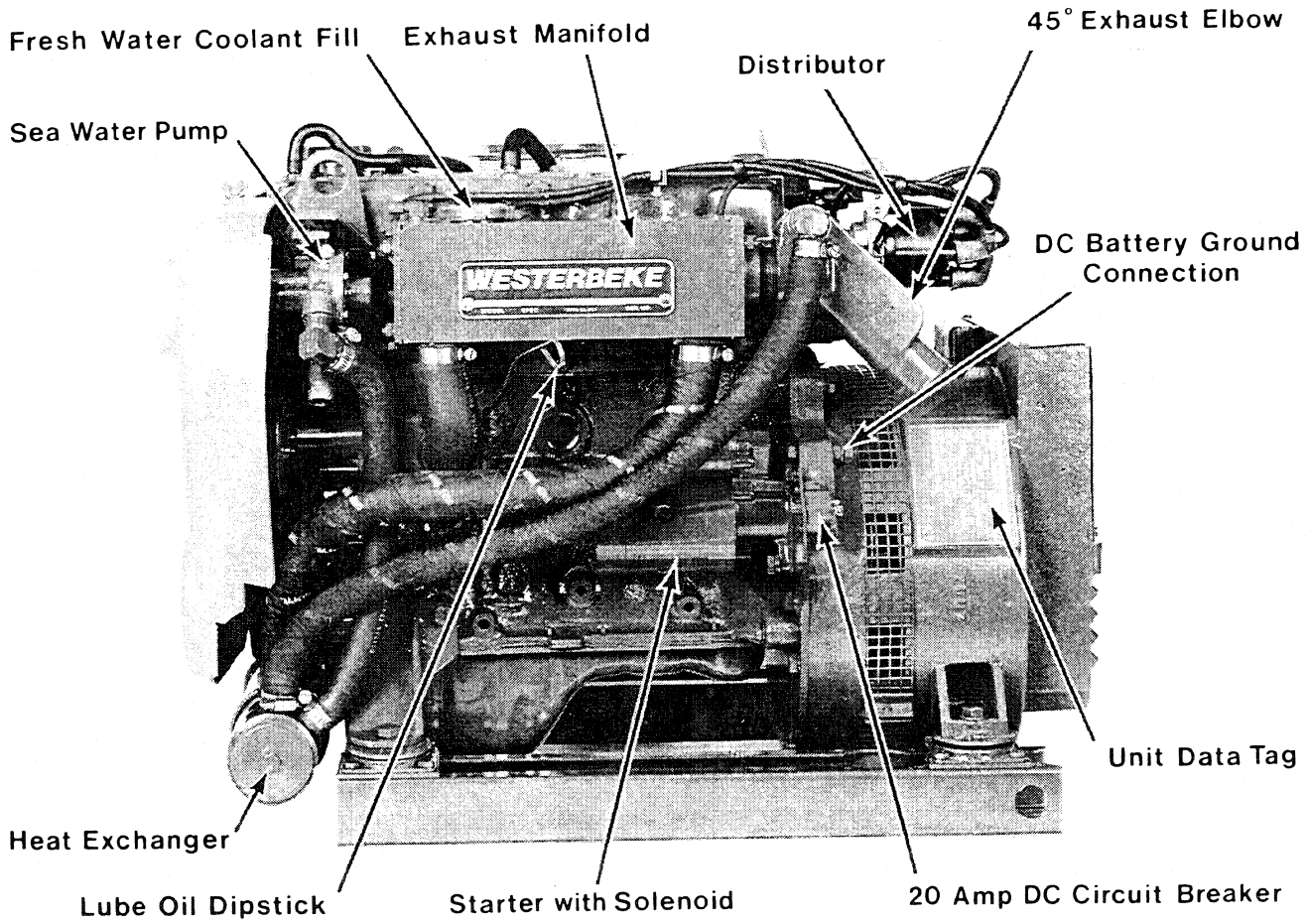

8.5 KW BTG Marine Gasoline Generator

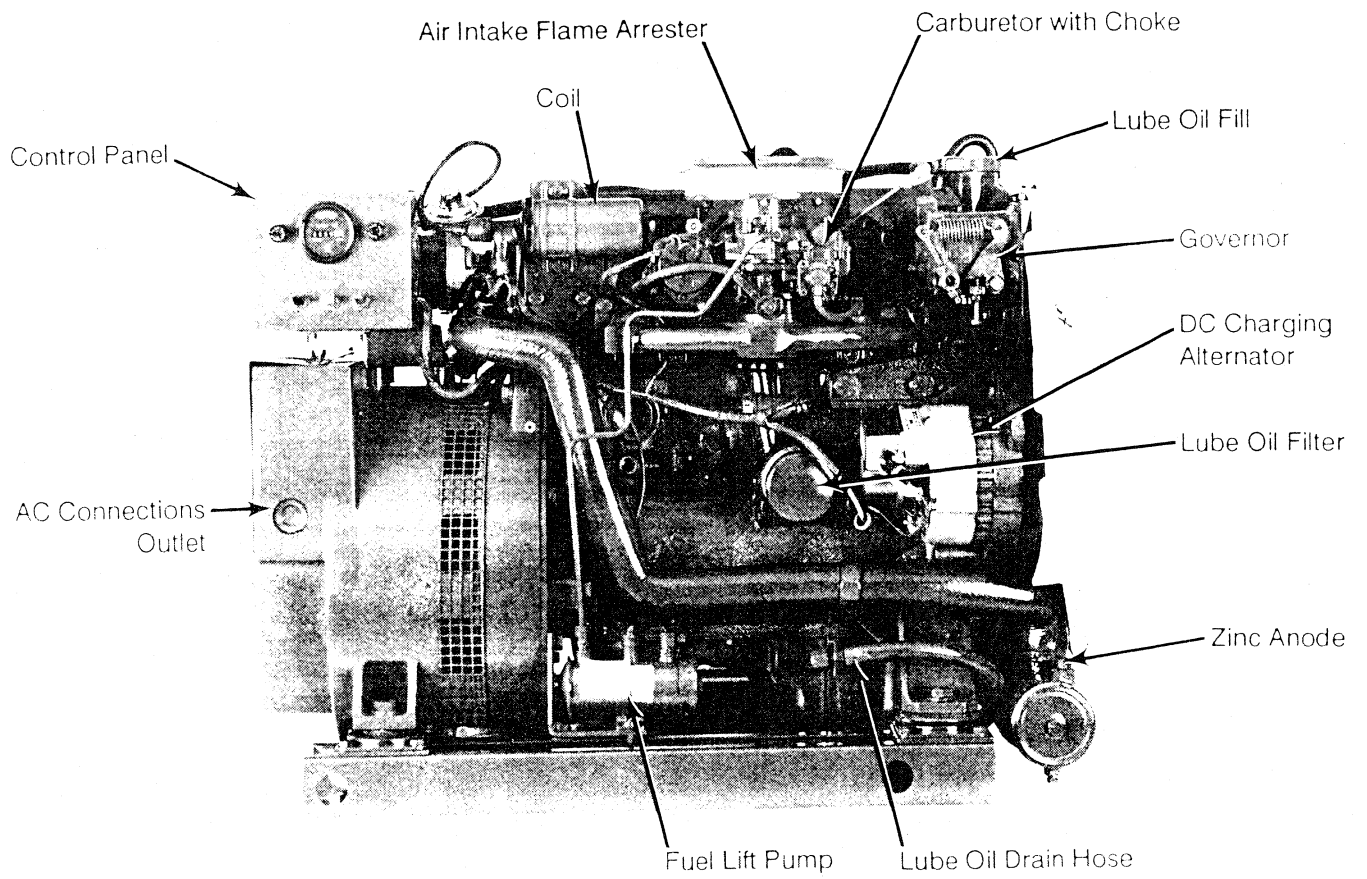

12.5 & 15.0 KW BTG Marine Gasoline Generator

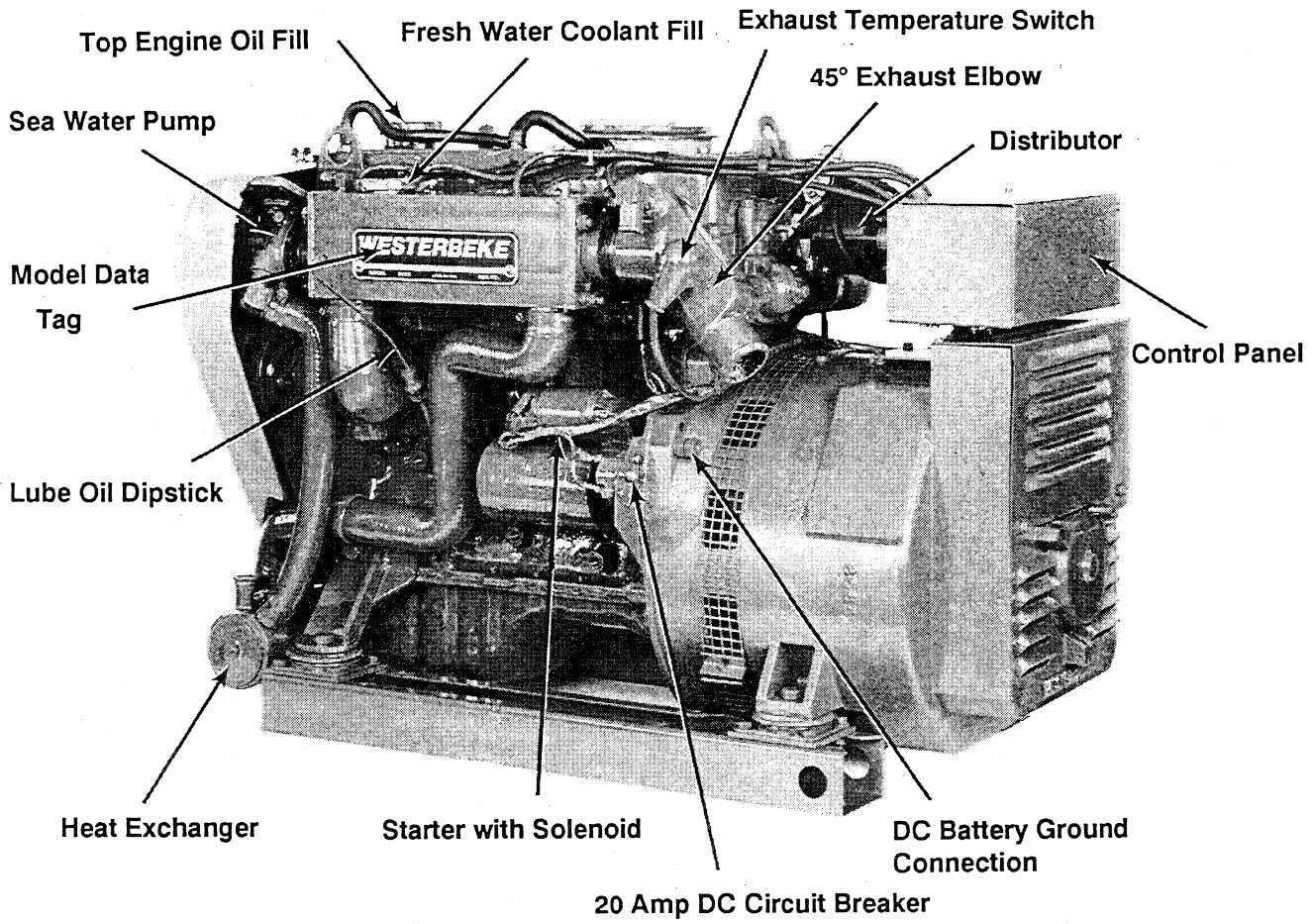

12.5 & 15.0 KW BTG Marine Gasoline Generator

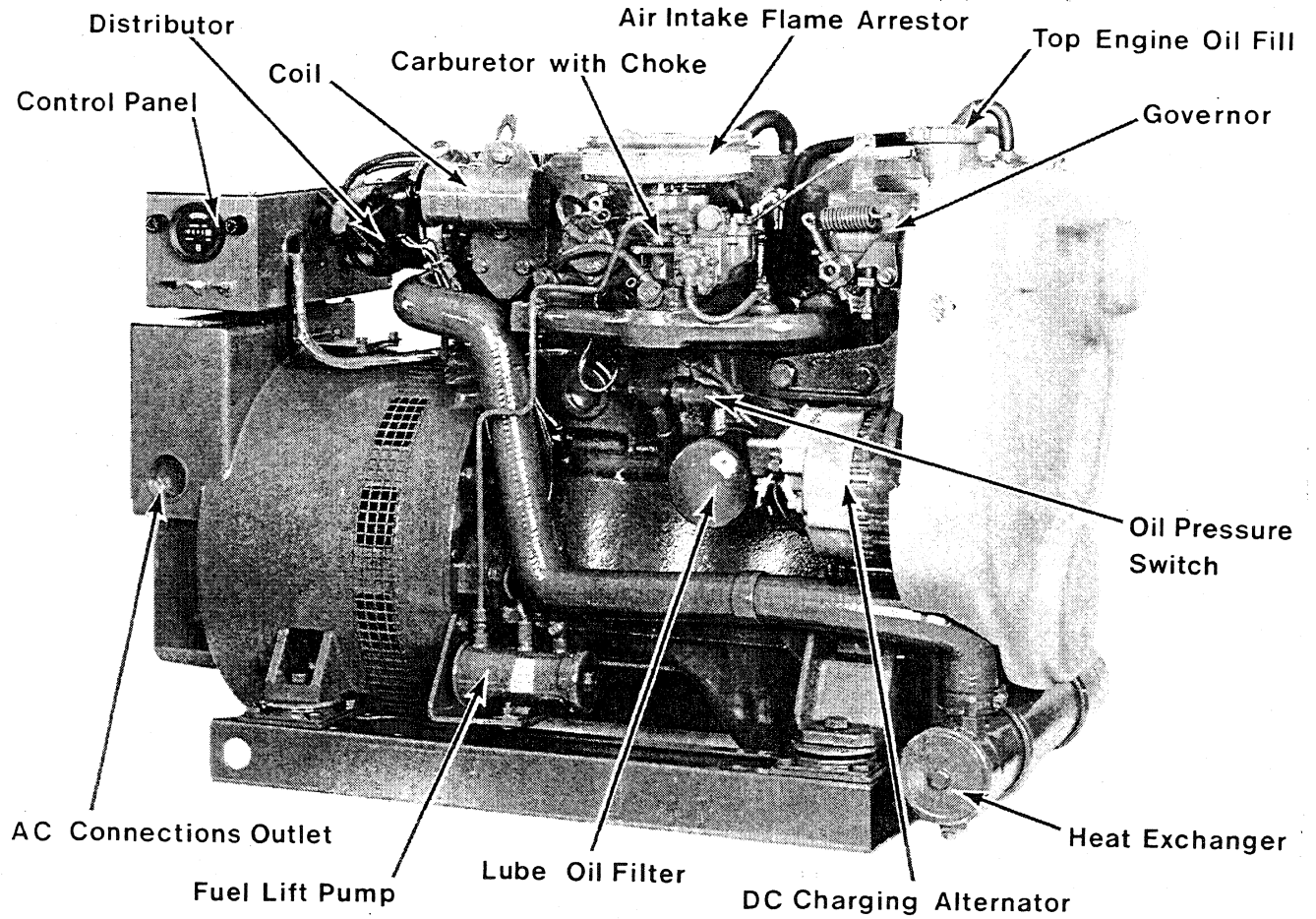

GENERAL

Introduction

This manual is a general guide to the installation, start-up, operation and maintenance of your Westerbeke marine gasoline engine-driven generator. The information contained in this manual is vital to your engine's dependable, long-term operation.

- A. Read it.
- B. Keep it in a safe, dry place.
- C. Keep it handy for reference at all times.

Understanding the Gasoline Driven Generator

The gasoline engine driving an AC generator is in many ways similar to a gasoline automobile engine. The cylinders are vertical in-line, and the engine's cylinder head has an overhead camshaft which is chain-driven. The engine utilizes a solid-state distributor which is horizontally mounted and camshaft-driven. The engine incorporates a pressure type lubrication system and a fresh water-cooled engine block which is thermostat-controlled. To a large degree, the generator's engine requires the same preventive maintenance that is required of a gasoline automobile engine. The most important factors to the generator's longevity are proper ventilation, maintenance of the fuel system, ignition system, cooling system, lubrication system and the AC alternator.

Ordering Parts

Whenever replacement parts are needed, always provide the generator model number designation (i.e. 8.5 KW BTG), engine serial number, and generator serial number as they appear on the data plates located on the generator end and on the exhaust manifold. You *must* provide us with this information so we may properly identify your generator set. In addition, include a complete part description and part number for each part needed (see the separately furnished Parts List). Also, be sure to insist upon Westerbeke factory packaged parts because "will fit" or generic parts are frequently not made to the same specifications as original equipment.

Note that component locations in the manual are referenced from the front of the engine which is the pulley/drive belt end. (The flywheel/generator end is the rear end.) Left and right sides are determined by the engine; imagine straddling the engine and facing in the same direction as the front of the engine: the left side is at your left, the right side at your right.

Westerbeke generator sets are thoroughly checked and given a final run under various load conditions before leaving the factory. This is done to ensure dependable operation, long service, and a satisfied owner.

Care at the factory during assembly and thorough testing have resulted in a Westerbeke gasoline engine-driven generator capable of many thousands of hours of dependable service. However, what the manufacturer cannot always control is the manner or location the generator is installed in the vessel or the manner in which the unit is operated and serviced in the field. That part is up to the buyer/owner-operator.

**8.5 KW BTG , 12.5 KW BTG AND 15.0 KW BTG
ENGINE SERVICE SPECIFICATIONS**

NOTE: All dimensions and specifications contained in this section are given in inches then millimeters. For example, 0.002 (0.5 mm).

	Specified Value	Allowable Limit
Cylinder Head		
Height	3.563 (90.5 mm)	
Warp limit	-	0.006 (0.15 mm)
Grinding limit	-	0.008 (0.20 mm)
Valves		
Valve head diameter	(Intake) 1.4154 - 1.4193 (35.95 - 36.05 mm)	
	(Exhaust) 1.2185 - 1.2225 (30.95 - 31.05 mm)	
Valve seat width	(Intake) 0.055 (1.4 mm) (Exhaust) 0.055 (1.4 mm)	
Valve seat angle	45°	
Height from valve spring base to the top of the valve collar (see page 76)	(Intake) 1.555 (39.5 mm) (Exhaust) 1.555 (39.5 mm)	
Valve seat sinking limit	-	(Intake) 0.059 (1.5 mm) (Exhaust) 0.059 (1.5 mm)
Valve head minimum thickness (Margin)	0.0394 (1.0 mm)	
Valve stem outer diameter	(Intake) 0.3161 - 0.3167 (8.030 - 8.045 mm)	0.3142 (7.980 mm)
	(Exhaust) 0.3159 - 0.3167 (8.025 - 8.045 mm)	0.3140 (7.975 mm)
Valve Guide Bushing		
Valve stem-to-guide clearance	0.0007 - 0.0021 (0.018 - 0.053 mm)	0.0079 (0.20 mm)

	Specified Value	Allowable Limit
Valve Spring		
Free length	1.705 (43.3 mm)	1.654 (42.0 mm)
Tension as installed - lbs (kg)	164 (2.925 mm)	
Valve spring squareness limit	-	0.059 (1.51 mm)
Valve Rocker Shaft and Rocker Arm		
Bore in rocker arm	0.7480 - 0.7493 (19.0 - 19.033 mm)	
Rocker arm shaft diameter	0.7464 - 0.7473 (18.959 - 18.980 mm)	
Clearance in rocker arm	0.0008 - 0.0029 (0.020 - 0.74 mm)	0.0039 (0.10 mm)
Cylinder Block		
Limit of distortion of cylinder block		0.006 (0.15 mm)
Cylinder bore diameter		
8.5 KW BTG	70.0 - 70.019 (2.7559 - 2.7567 mm)	
12.5 KW BTG and 15.0 KW BTG	3.0315 - 3.0323 (77.0 - 77.019 mm)	
Inner diameter error for each cylinder		0.0035 (0.09 mm)
Maximum difference in bore		0.0059 (0.15 mm)
Boring size		
8.5 KW BTG	0.010 (0.25 mm) 0.020 (0.50 mm) 0.030 (0.75 mm) 0.040 (1.00 mm)	
12.5 KW BTG and 15.0 KW BTG	0.010 (0.25 mm) 0.020 (0.50 mm)	

Piston, Piston Pin, and Piston Ring	Specified Value	Allowable Limit
Piston diameter (measured at 90° to pin bore axis, and 0.709 [18 mm] below oil ring groove)		
8.5 KW BTG	2.7537 - 2.7545 (69.944 - 69.964 mm)	
12.5 KW BTG	3.0293 - 3.0301 (76.944 - 76.964 mm)	
15.0 KW BTG	3.0297 - 3.0305 (76.954 - 76.974 mm)	
Piston-to-cylinder clearance - inches (mm)		
8.5 KW BTG	0.0014 - 0.0030 (0.036 - 0.075 mm)	0.0059 (0.15 mm)
12.5 KW BTG	0.0014 - 0.0030 (0.036 - 0.075 mm)	0.0059 (0.15 mm)
15.0 KW BTG	0.0010 - 0.0026 (0.026 - 0.065 mm)	0.0059 (0.15 mm)
Ring groove width		
First (Top)	0.048 - 0.050 (1.22 - 1.24 mm)	
Second	0.0598 - 0.0606 (1.52 - 1.54 mm)	
Oil ring groove	0.1583 - 0.1591 (4.02 - 4.04 mm)	
Piston ring thickness		
First (Top)	0.0461 - 0.0469 (1.17 - 1.19 mm)	
Second	0.0579 - 0.0587 (1.47 - 1.49 mm)	

Piston, Piston Pin, and Piston Ring (continued)	Specified Value	Allowable Limit
Clearance between piston ring and ring groove		
First (Top)	0.0012 - 0.0028 (0.03 - 0.07 mm)	0.0059 (0.15 mm)
Second	0.0012 - 0.0028 (0.03 - 0.07 mm)	0.0059 (0.15 mm)
Piston ring end gap		
First (Top)	0.008 - 0.016 (0.2 - 0.4 mm)	0.0039 (1.0 mm)
Second	0.008 - 0.016 (0.2 - 0.4 mm)	0.0039 (1.0 mm)
Oil ring	0.012 - 0.035 (0.3 - 0.9 mm)	0.0039 (1.0 mm)
Available oversize piston rings (see parts list)		
8.5 KW BTG	0.010 (0.25 mm) 0.020 (0.50 mm) 0.030 (0.75 mm) 0.040 (1.00 mm)	
12.5 KW BTG and 15.0 KW BTG	0.010 (0.25 mm) 0.020 (0.50 mm)	
Piston pin diameter	0.7865 - 0.7869 (19.976 - 19.988 mm)	
Interference in piston (press fit tolerance)	0.0009 (0.024 mm)	
Installation pressure - lb (kg)	1,102 - 3,307 (500 - 1,500 kg)	

Connecting Rod

Length center-to-center	5.352 - 5.356 (135.95 - 136.05 mm)	
Maximum twist of rod per 3.94 inches (100 mm)		0.0016 (0.04 mm)
Small end bore	0.7854 - 0.7859 (19.948 - 19.961 mm)	

	Specified Value	Allowable Limit
Connecting Rod (continued)		
Clearance between piston pin and small end bore	-0.0006 to -0.0016 (-0.015 to -0.040 mm)	
Connecting rod side clearance	0.004 - 0.010 (0.11 - 0.262 mm)	0.012 (0.3 mm)
Crankpin bearing clearance (oil clearance)	0.0009 - 0.0019 (0.024 - 0.048 mm)	0.0039 (0.10 mm)
Available undersize bearing	0.010 (0.25 mm) 0.020 (0.50 mm) 0.030 (0.75 mm)	
Crankshaft and Main Bearing		
Crankshaft run-out	-	0.0012 (0.03 mm)
Crankpin diameter	1.5724 - 1.5734 (39.940 - 39.956 mm)	
Wear limit of diameter		0.0020 (0.05 mm)
Grinding limit		0.03 (0.75 mm)
Main journal diameter	1.9661 - 1.9668 (49.938 - 49.956 mm)	
Wear limit of journal		0.002 (0.05 mm)
Grinding limit		0.03 (0.75 mm)
Main journal bearing clearance	0.0009 - 0.0017 (0.023 - 0.042 mm)	0.0031 (0.08 mm)
Available undersize bearing	0.010 (0.25 mm) 0.020 (0.50 mm) 0.030 (0.75 mm)	
Crankshaft end play	0.0039 - 0.0059 (0.10 - 0.15 mm)	0.0118 (0.30 mm)
Available undersize thrust bearing	0.010 (0.25 mm) 0.020 (0.50 mm) 0.030 (0.75 mm)	

Camshaft	Specified Value	Allowable Limit
Camshaft run-out	0.0012 (0.03 mm)	
Camshaft end play	0.001 - 0.007 (0.02 - 0.18 mm)	0.008 (0.20 mm)
Journal diameter		
Front	1.6515 - 1.6522 (41.949 - 41.965 mm)	
Center	1.6504 - 1.651 (41.919 - 41.935 mm)	
Rear	1.6515 - 1.6522 (41.949 - 41.965 mm)	
Wear limit of journal		0.0020 (0.05 mm)
Camshaft bearing clearance (oil clearance)		
Front	0.0014 - 0.0030 (0.035 - 0.076 mm)	0.0059 (0.15 mm)
Center	0.0026 - 0.0042 (0.065 - 0.106 mm)	0.0059 (0.15 mm)
Rear	0.0014 - 0.0030 (0.035 - 0.076 mm)	0.0059 (0.15 mm)
Cam lobe height		
8.5 KW BTG Intake	1.7401 (44.119 mm)	1.7291 (43.919 mm)
Exhaust	1.7401 (44.119 mm)	1.7291 (43.919 mm)
12.5 KW BTG and 15.0 KW BTG Intake	1.7337 (44.114 mm)	1.7258 (43.914 mm)
Exhaust	1.7337 (44.114 mm)	1.7258 (43.914 mm)
Water pump		
Impeller press-fit pressure - lb (kg)	2,645 - 2,866 (1,200 - 1,300 kg)	
Cooling Circuit		
Cooling circuit checking pressure - psi (kg/cm ²)	18 ± 1 (1.26 ± 0.1)	

	Specified Value	Allowable Limit
Electrical System		
Starting battery (recommended)	12 volt, 26 A-H	(35 A-H in cold areas)
Starter	12 volt, 1.2 KW, reduction type, solenoid-mounted.	
No-load performance	Less than 90 amp at 11.5 volts	
Alternator	35 or 50 amps	
Internal regulator	12 volts at 35 or 50 amps	
Ignition System		
Distributor		
Dwell angle	49 - 55°	
Ignition coil		
Primary coil resistance	ohm 3.1	
Secondary coil resistance	ohm 10 - 30k	
Insulation resistance	ohm 10M	
External resistor resistance	ohm 1.6	
High tension cord resistance	ohm 16,000 per 3.28 ft (1 m)	
Lubricating System		
General	Pressure type by Trochoid pump, chain-driven by crankshaft.	
Oil filter	Full flow, paper element, spin-cartridge.	
Oil sump capacity (filter included) - qts U.S. (liters)	3.9 (3.7 liters)	-
Oil pressure at 1800 rpm engine speed (engine hot)	25 - 35 psi 1.75 - 2.50 kg/cm ²	- -
Oil pump		
Outer rotor and body clearance	0.0078 - 0.0116 (0.20 - 0.294 mm)	0.0134 (0.35 mm)
Clearance between rotor lobes	0.0012 - 0.0047 0.03 - 0.12 mm)	0.0098 (0.25 mm)

Lubricating System (continued)	Specified Value	Allowable Limit
Rotor end float	0.0016 - 0.0039 (0.04 - 0.10 mm)	0.0059 (0.15 mm)
Pump shaft and body clearance	0.0008 - 0.0022 (0.02 - 0.056 mm)	0.0039 (0.10 mm)
Free length of plunger	1.791 (45.5 mm)	
Sprocket pressing pressure - lb (kg)	1,543 - 2,865 (700 - 1,300 kg)	

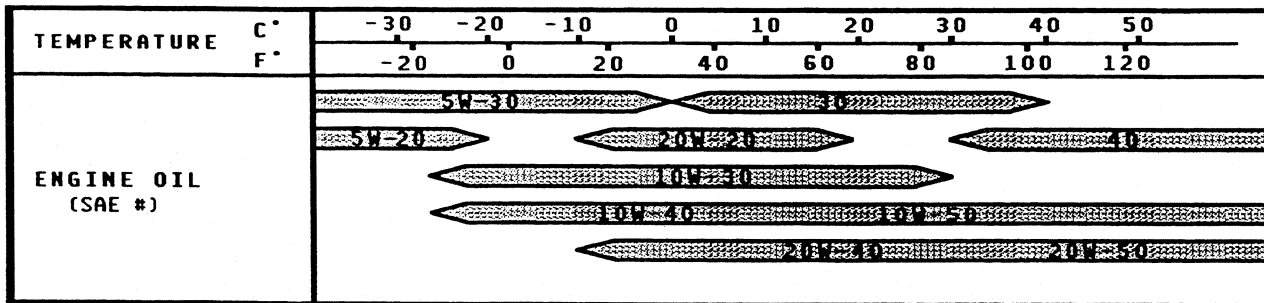

Lubricant: API SPECIFICATION OF SD, SE, SF, SG OR SJ GRADE IN ACCORDANCE WITH THERMAL ENVIRONMENT (SEE TABLE).

Cooling System

General	Fresh water-cooled block, thermostatically-controlled, with sea water heat exchanger system.	
Operating Temperature ° F (° C)	130 - 150 (55 - 66)	
Fresh water pump	Centrifugal type, metal impeller, V-belt-driven.	
Sea water pump	Positive displacement, rubber impeller, belt-driven.	
Sea water flow at 1800 rpm (measured at discharge point from heat exchanger)	8.5 KW BTG and 12.5 KW BTG	6.7 gpm (25.3 lpm)
	15.0 KW BTG	6.7 gpm (25.3 lpm)

	Specified Value	Allowable Limit
Cooling System (continued)		
System capacity (fresh water) - qts (liters)		
8.5 KW BTG and 12.5 KW BTG	6.5 (6.2 liters)	-
15.0 KW BTG	6.5 (6.2 liters)	-
Fuel System		
Fuel	Unleaded or leaded gasoline with a minimum octane rating of 89.	
Carburetor	Conventional carburetor type with fuel pump.	
Governor	Mechanical, belt-driven.	
Lift pump	12 volt electric; lift capacity 5 feet (1.5 meters).	
Flame Arrester	Metal screen type, cleanable.	
Fuel filter	Screen element in carburetor inlet. (Early models had cleanable screen in base of fuel pump.)	
Engine fuel consumption at full rated KW output - gal (U.S.)/hr. (liters/hr.)		
8.5 KW BTG	1.10 (4.16)	-
12.5 KW BTG	1.25 (4.73)	-
15.0 KW BTG	1.6 (6.05)	-

ENGINE TUNE-UP SPECIFICATIONS

Spark Plug Gap - inches (mm)	0.031 ± 0.002 (0.80 ± 0.05 mm)	
Contact Point Clearance - inches (mm)	0.020 ± 0.002 (0.50 ± 0.05 mm)	
Dwell Angle	49 - 55°	
Condenser Capacity	0.20 ± 0.022 microfarads (uF)	
Valve Clearance (engine warm) - inches (mm)	Intake 0.010 (0.25 mm)	Exhaust 0.012 (0.30 mm)
Timing		
8.5 KW BTG	1800 rpm	14° BTDC ± 1°
12.5 KW BTG and 15.0 KW BTG	1800 rpm	18° BTDC ± 1°

AC GENERATOR SPECIFICATIONS

General

Brushless, four-pole, revolving field, single-bearing design, reconnectable, single-phase, transformer regulation (with optional solid-state voltage regulation).

Voltage

120 volts or 120/240 volts, 60 hertz;
110 volts or 110/220 volts, 50 hertz;
voltage regulation: $\pm 5\%$, no-load to full rated output; 3 hertz (5%) no-load to full rated output.

Rating at 60 Hertz (at 1800 rpm)

8.5 KW BTG - 614	120 volts 120/240 volts	70 amps 70/35 amps
12.5 KW BTG - 614	120 volts 120/240 volts	104 amps 104/52 amps
15.0 KW BTG - 614	120 volts 120/240 volts	124 amps 124/62 amps

Rating at 50 Hertz (at 1500 rpm)

6.8 KW BTG - 514	220 volts	31 amps
10.0 KW BTG - 514	220 volts	47 amps
12.0 KW BTG - 514	220 volts	55 amps

Generator Cooling Air Requirements (at 1800 rpm)

8.5 KW BTG	200 cubic feet/minute
12.5 KW BTG	220 cubic feet/minute
15.0 KW BTG	250 cubic feet/minute

Note: Increase air supply 15% for 50 hertz operation (1500 rpm).

Engine Combustion Air requirements (60 hertz at 1800 rpm)

8.5 KW BTG	35 cubic feet/minute
12.5 KW BTG	41.1 cubic feet/minute
15.0 KW BTG	47 cubic feet/minute





TIGHTENING TORQUE REQUIREMENTS





	Lb-ft	Kg-m
Cylinder head to cylinder block	56 - 59	7.8 - 8.2
Crankshaft pulley to crankshaft	80 - 87	11 - 12
Manifold to cylinder head	14 - 19	1.9 - 2.6
Main bearing caps to cylinder block	48 - 51	6.6 - 7.1
Connecting rod bearing caps to connecting rod	22 - 25	3.0 - 3.5
Spark plug to cylinder head	11 - 17	1.5 - 2.3
Oil pan	5 - 9	0.7 - 1.2
Oil filter	Firmly by hand	Firmly by hand
Oil pump	14 - 22	1.9 - 3.1
Oil pressure switch	9 - 13	1.2 - 1.8
Flywheel to crankshaft	60 - 65	8.3 - 9.0
Timing chain cover	14 - 22	1.9 - 3.1
Thermostat cover	14 - 22	1.9 - 3.1
Water pump	14 - 22	1.9 - 3.1

TABLE OF STANDARD HARDWARE TIGHTENING TORQUES

Unless stated for a specific assembly, use the following torque values when tightening standard hardware.

	Pitch	lb-ft	kg-m
<u>Grade 4T</u>			
6mm bolt head/nut	1	2.9 - 5.1	0.4 - 0.7
8mm bolt head/nut	1.25	7.2 - 11.6	1.0 - 1.6
10mm bolt head/nut	1.25	13.7 - 22.4	1.9 - 3.1
10mm bolt head/nut	1.5	13.0 - 21.7	1.8 - 3.0
12mm bolt head/nut	1.25 (ISO)	25.3 - 39.8	3.5 - 5.5
12mm bolt head/nut	1.5	25.3 - 39.8	3.5 - 5.5
12mm bolt head/nut	1.75	21.7 - 36.2	3.0 - 5.0
13mm bolt head/nut	1.5	32.5 - 50.6	4.5 - 7.0
14mm bolt head/nut	1.5	36.2 - 57.9	5.0 - 8.0
14mm bolt head/nut	2	34.0 - 55.7	4.7 - 7.7
16mm bolt head/nut	1.5	54.2 - 79.6	7.5 - 11.0
16mm bolt head/nut	2	51.4 - 76.7	7.1 - 10.6
<u>Grade 6T</u>			
6mm bolt head/nut	1	4.3 - 6.5	0.6 - 0.9
8mm bolt head/nut	1.25	10.8 - 15.9	1.5 - 2.2
10mm bolt head/nut	1.25	21.7 - 32.5	3.0 - 4.5
10mm bolt head/nut	1.5	19.5 - 30.4	2.7 - 4.2
12mm bolt head/nut	1.25 (ISO)	36.2 - 57.9	5.0 - 8.0
12mm bolt head/nut	1.5	36.2 - 50.6	5.0 - 7.0
12mm bolt head/nut	1.75	34.7 - 49.2	4.8 - 6.8
<u>Grade 7T, 8T and 8.8</u>			
6mm bolt head/nut	1	5.8 - 8.7	0.8 - 1.2
8mm bolt head/nut	1.25	14.5 - 21.7	2.0 - 3.0
10mm bolt head/nut	1.25	28.9 - 39.8	4.0 - 5.5
10mm bolt head/nut	1.5	26.8 - 37.6	3.7 - 5.2
12mm bolt head/nut	1.25 (ISO)	54.2 - 75.9	7.5 - 10.5
12mm bolt head/nut	1.5	50.6 - 65.1	7.0 - 9.0
12mm bolt head/nut	1.75	43.4 - 61.5	6.0 - 8.5
13mm bolt head/nut	1.5	57.9 - 86.8	8.0 - 12.0
14mm bolt head/nut	1.5	72.3 - 108.5	10.0 - 15.0
14mm bolt head/nut	2	68.7 - 101.3	9.5 - 14.0
16mm bolt head/nut	1.5	108.5 - 166.4	15.0 - 23.0
16mm bolt head/nut	2	101.3 - 159.1	14.0 - 22.0
<u>Grade 5 capscrew</u>			
1/4 UNC		9 - 11	1.2 - 1.5
1/4 UNF		11 - 13	1.5 - 1.8
5/16 UNC		18 - 20	2.5 - 2.8
5/16 UNF		21 - 23	2.9 - 3.2
3/8 UNC		28 - 33	3.7 - 4.6
3/8 UNF		30 - 35	4.1 - 4.8
7/16 UNC		44 - 49	6.1 - 6.8
7/16 UNF		50 - 55	6.9 - 7.6
1/2 UNC		68 - 73	9.4 - 10.1
1/2 UNF		73 - 80	10.1 - 11.1

Grade of Bolt		SAE 1&2	SAE 5	SAE 6	SAE 8	U.S. Standard	
Minimum Tensile Strength		64,000 P.S.I.	105,000 P.S.I.	133,000 P.S.I.	150,000 P.S.I.		
Grade Markings on Head						Socket or Wrench Size	
U.S. Standard		Torque (in Foot Pounds)				U.S. Regular	
Bolt Diameter	Dec. Equiv.					Bolt Head	Nut
1/4	.25	5	7	10	10.5	3/8	7/16
5/16	.3125	9	14	19	22	1/2	9/16
3/8	.375	15	25	34	37	9/16	5/8
7/16	.4375	24	40	55	60	5/8	3/4
1/2	.50	37	60	85	92	3/4	13/16
9/16	.5625	53	88	120	132	7/8	7/8
5/8	.625	74	120	167	180	15/16	1
3/4	.75	120	200	280	296	1-1/8	1-1/8
7/8	.875	190	302	440	473	1-5/16	1-5/16
1	1.00	282	466	680	714	1-1/2	1-1/2

Grade of Bolt		5D	8G	10K	12K	Metric Standard	
Minimum Tensile Strength		71,160 P.S.I.	113,800 P.S.I.	142,000 P.S.I.	170,674 P.S.I.		
Grade Markings on Head						Socket or Wrench Size	
Metric Standard		Torque (in Foot Pounds)				Metric Standard	
Bolt Diameter	U.S. Dec. Equiv.					Bolt Head	Nut
6mm	.2362	5	8	8	10	10mm	10mm
8mm	.3150	10	18	22	27	14mm	14mm
10mm	.3937	19	31	40	49	17mm	17mm
12mm	.4720	34	54	70	86	19mm	19mm
14mm	.5512	55	89	117	137	22mm	22mm
16mm	.6299	83	132	175	208	24mm	24mm
18mm	.709	111	182	236	283	27mm	27mm
22mm	.8661	182	284	394	464	32mm	32mm
24mm	.945	261	419	570	689	36mm	36mm

GENERATOR OVERHAUL

Section.....	Page
PREPARATIONS	64
DISASSEMBLY FOR OVERHAUL.....	65
ENGINE DISASSEMBLY	67
ENGINE BLOCK DISASSEMBLY.....	68
ENGINE INSPECTION AND REPAIR	71
Checking the Cylinder Head.....	71
Checking Valve Guides.....	71
Replacing the Valve Guides.....	72
Checking the Valves.....	73
Checking Valve Springs.....	73
Checking the Valve Seat.....	74
Refacing the Valve and Valve Seat.....	75
Checking the Rocker Arm and Shaft.....	75
Checking the Cylinder Block.....	76
Checking the Pistons.....	77
Checking the Piston Rings.....	77
Checking the Connecting Rods.....	78
Checking the Connecting Rod Bearings.....	79
Checking the Crankshaft.....	79
Checking the Main Bearing.....	80
Checking The Camshaft.....	81
Checking the Flywheel and Ring Gear.....	81
Checking the Chain, the Chain Adjuster, the Damper, and the Sprocket.....	82
ENGINE ASSEMBLY	83

PREPARATIONS

1. Remove all AC and DC power connections from the unit.
2. Shut off and disconnect all fuel lines, sea water and exhaust connections.
3. Unbolt the unit and carefully move it to the overhaul shop.
4. Once at the overhaul shop, drain all lubricating oil and coolant from the engine and exchanger system.
5. Clean the exterior of the generator of all oil and dirt deposits.

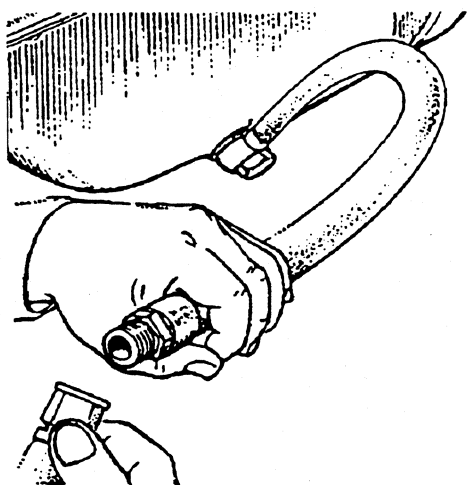

Oil Sump Drain

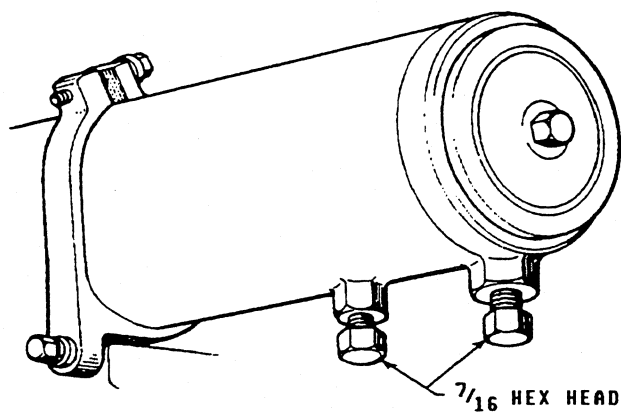

Heat Exchanger Drains

DISASSEMBLY FOR OVERHAUL

Removal of the Generator End from the Engine

1. Disconnect harness leads from the engine connections and tag and mark all harness connections. Unbolt the control panel from the generator's control panel as one assembly.
2. Supporting the rear of the engine, unbolt the generator end's bell cover.

NOTE: The Housing Puller Tool listed in the "FIELD FABRICATED TOOLS" section of this manual will help make the removal of the generator housing easier.

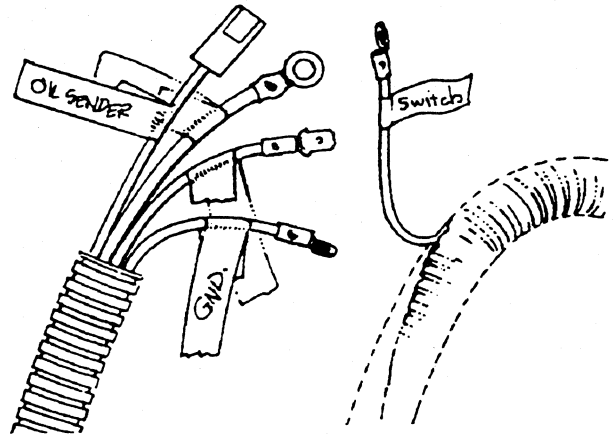

3. With the aid of the Housing Puller Tool attached to the end bearing support web and armature shaft, carefully draw the generator housing off the rear support bearing. In some cases, the rear support bearing may be pulled off the armature shaft along with the generator housing.
4. When clear of the bearing and/or shaft, carefully slide the generator housing off the armature. Refer to the illustration below for an exploded view of the BTG generator end.

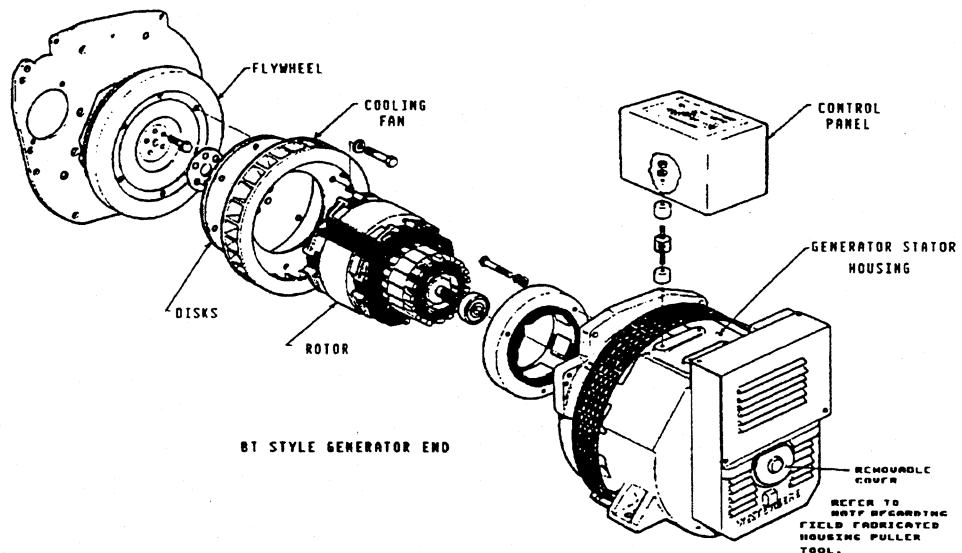

5. For all generator models, remove the rotor and fan assembly from the flywheel.

6. Remove the engine's flywheel.

Now that the generator end has been removed, the engine can be disassembled.

ENGINE DISASSEMBLY

This section describes the disassembly of the engine when performing a complete overhaul of the unit. The procedures which follow include the disassembly of subassemblies, inspection of their components parts, repair or replacement of these parts (if necessary), and the reassembly of the subassemblies.

Removal of External Parts and Subassemblies

1. Remove the exhaust manifold and related hoses as a unit. Disassemble and inspect these parts.
2. Remove the heat exchanger and its related hoses and mounts from the front of the engine. Have the heat exchanger cleaned and tested at a local automotive radiator repair shop or replace it if necessary.
3. Remove the starter motor and circuit breaker assembly. Examine the starter and have it repaired or replaced if necessary.
4. Loosen the belt guard's thumbscrews and remove the engine's belt guard from its brackets at the front of the engine.
5. Remove the sea water pump, the drive belt, and the sea water pump's mounting brackets.
6. Remove the alternator, the fresh water pump's drive belt, and the alternator's mounting bracket.
7. Disconnect the linkage arm between the governor and the carburetor at the ball joint (carburetor end of arm). Remove the governor and its mounting bracket.
8. Remove the fresh water circulating pump's pulley.
9. Remove the fresh water circulating pump.
10. Remove the fuel line, the carburetor, the fuel pump, and the intake manifold.
11. Remove the ignition coil and its mounting bracket.
12. Remove the engine's backplate.
13. Remove the water temperature switch and the water temperature sender.
14. Remove the oil pressure switch, the oil pressure sender, the oil filter, and the oil filter bracket.
15. Remove the thermostat housing and the thermostat.
16. Remove the crankshaft pulley from the crankshaft.
17. Remove the spark plugs from the cylinder head.
18. Remove the distributor from the rear of the engine.

The basic engine assembly is now ready for disassembly, cleaning, inspection, and repair if necessary.

ENGINE BLOCK DISASSEMBLY

Since the BTG generator engines are not as bulky nor as heavy as an automobile engine, the engines may be laid on a sturdy bench while they are disassembled and repaired. However, if an engine stand is readily available, the engine should be attached on the stand for your working convenience.

1. Remove the engine rocker cover and baffle assembly.
2. Rotate the engine crankshaft and position the camshaft drive chain so that the master link is in a position where it can be disassembled. Remove the chain tensioner from the front timing gear cover. Disassemble the master link to separate the chain.
3. Loosen the cylinder head bolts in numerical order as shown in the figure. Make sure the bolts are loosened a few turns at a time.
4. Remove the rocker shaft assembly and camshaft with drive gear.

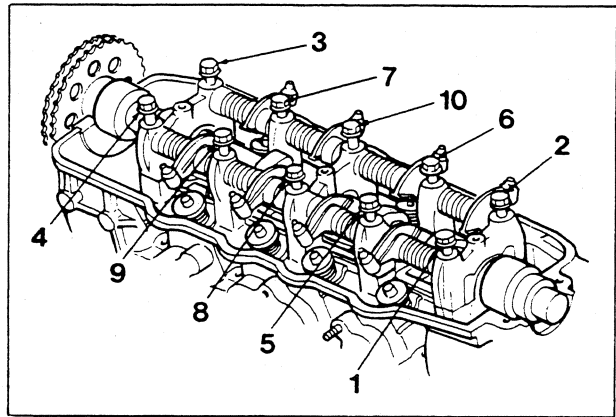

5. Remove the cylinder head and valves with the aid of a suitable valve spring compressor tool. Make sure the removed valves are kept in sequence for each cylinder.
6. Remove the engine oil sump.
7. Remove the front crankshaft pulley and front timing gear cover.
8. Remove the lube oil pump assembly and drive chain.
9. Remove each connecting rod bearing cap and remove the connecting rod and piston assembly from the engine block by carefully forcing it out the top of the block.

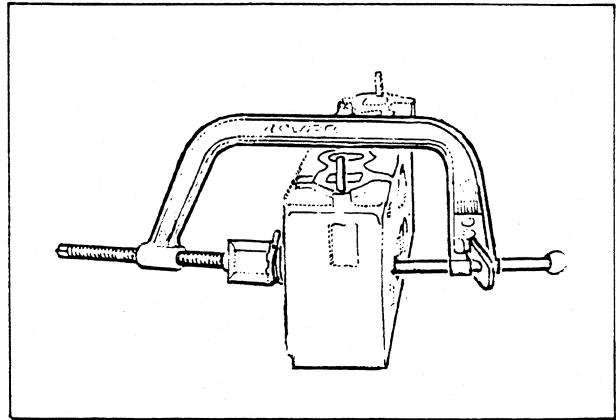

NOTE: Keep the rods and caps together. Number them as needed.

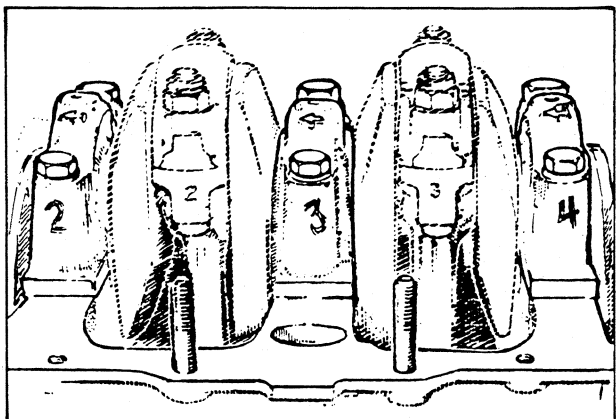

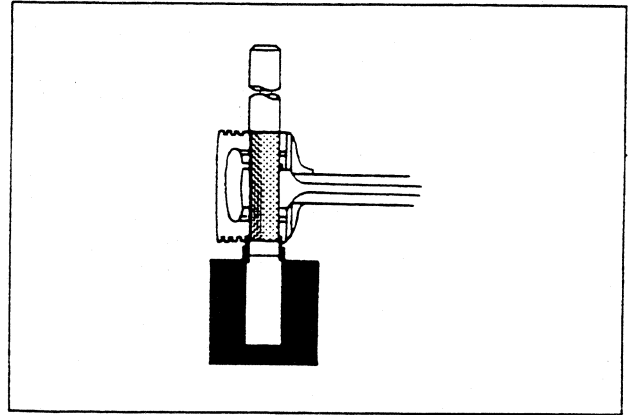
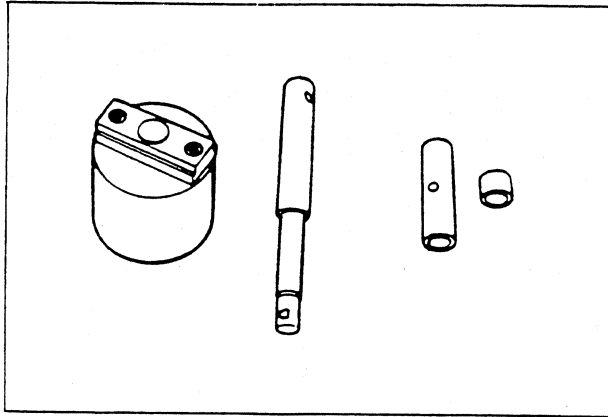

10. Press out the piston pin with the piston pin setting tool. Make sure that the disassembled pistons and piston rings are kept in sequence for each cylinder.
11. Remove the main bearing cap with the main bearing cap puller.
12. Remove the crankshaft main bearing inserts and thrust washers.

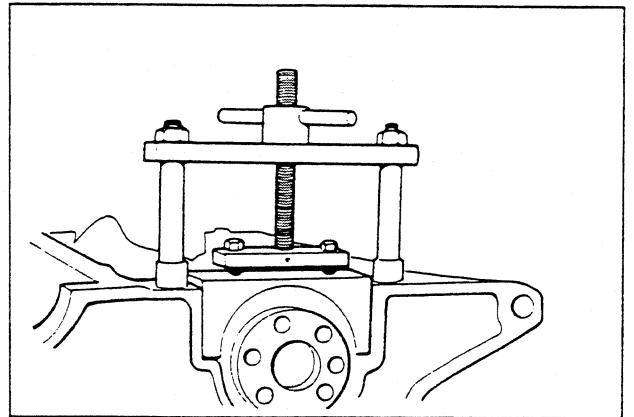

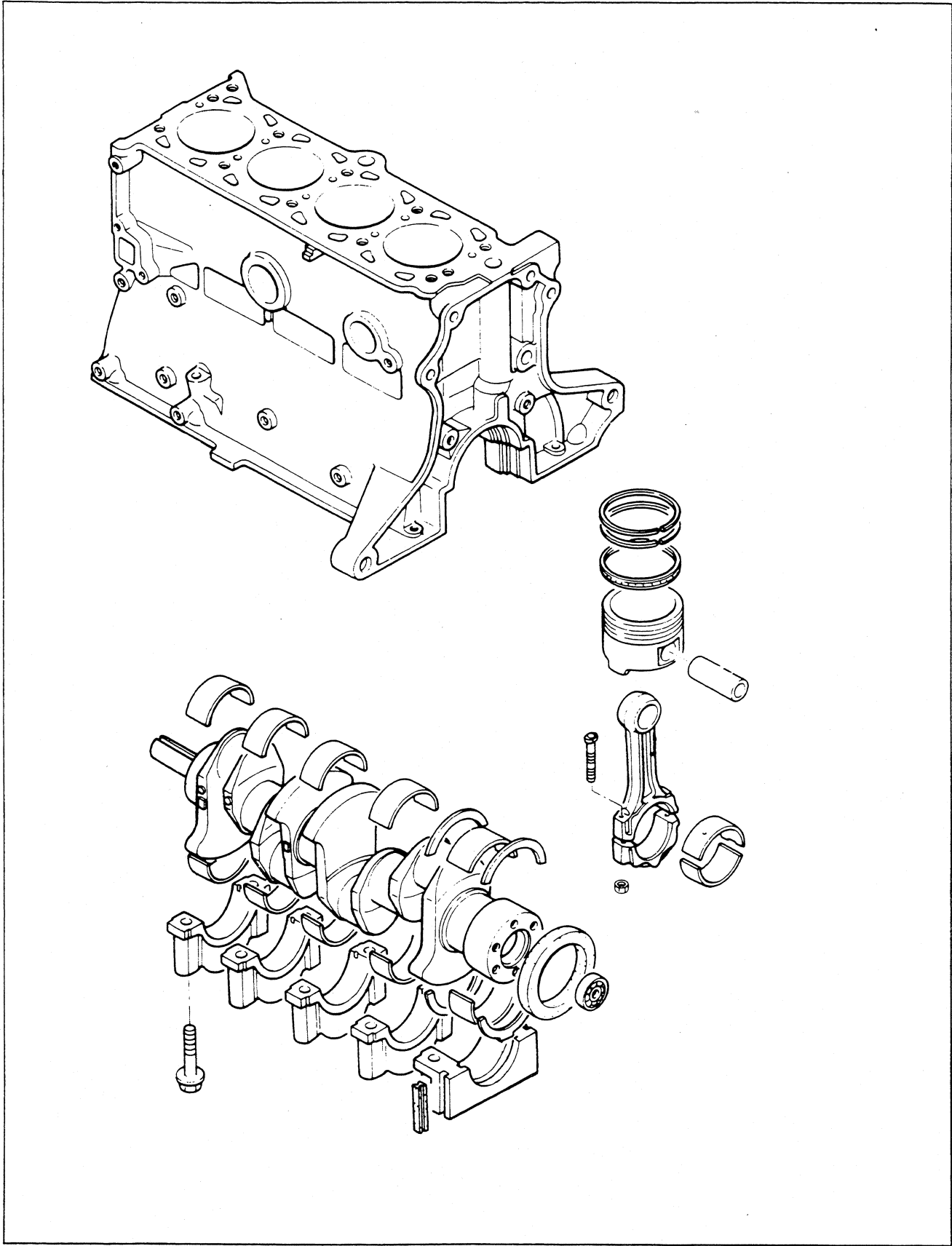

ENGINE INSPECTION AND REPAIR

NOTE: Before washing the cylinder head and block, check them for indications of water leaks, gas leaks, damage or cracks. Before checking, wash each part to remove any adhered foreign matter (pieces of gasket, dust, oil, carbon, scale, etc.). Since the cylinder head, cylinder head cover, timing chain cover and other engine parts are made of aluminum, handle them carefully to ensure against damage. **Do not** use cleaning solutions that will be harmful to the aluminum.

Checking the Cylinder Head

1. Replace the cylinder head if it has any damage such as water leaks, gas leaks, or cracks.
2. Measure the extent of warping (flatness) on the lower surface along the areas shown in the figure. If the warping is more than specifications, grind the surface or replace it.

Height of cylinder head: 90.5 mm (3.563 in).

Warp limit: 0.15 mm (0.006 in).

Grinding limit: 0.2 mm (0.008 in).

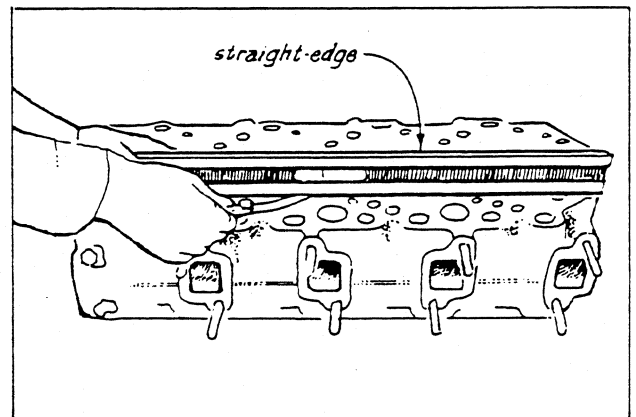
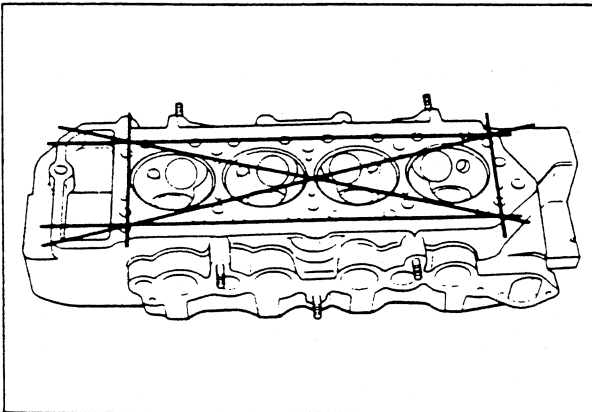

Checking the Valve Guides

Measure the clearance between the valve and guide. If the clearance exceeds the specified limit, replace the guide or valve, or both.

Clearance limit: 0.2 mm (0.0079 in).

Measuring Method #1

Check the difference between the inner diameter of the guide and the diameter of the valve stem.

Measuring Method #2

Check the valve deflection with a mounted dial indicator by moving the valve stem from side to side.

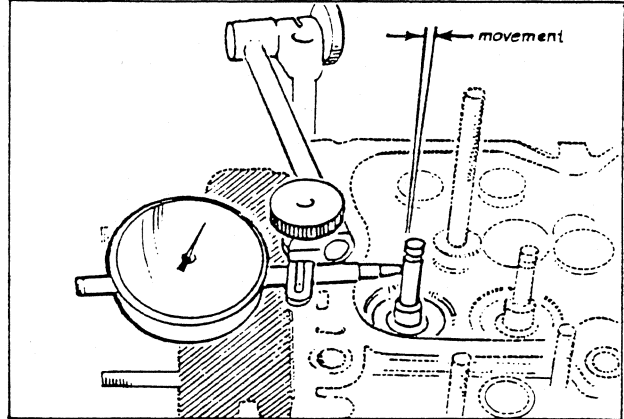
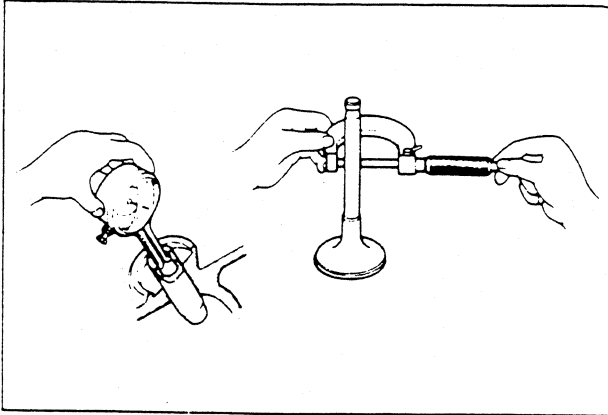

NOTE: Separate the valve from the valve seat before measuring. Measure at a position near the valve guide.

Replacing the Valve Guides

1. Remove the valve seal from the valve guide.
2. Knock the guide out toward the opposite side of the combustion chamber with a valve guide installer.
3. Place a clip on the new valve guide and drive it in from the opposite side of the combustion chamber with the valve guide installer

NOTE: The shape of the intake valve guides differ from that of the guides on the exhaust side.

4. Install the valve seal on the valve guide with a valve seal pusher.

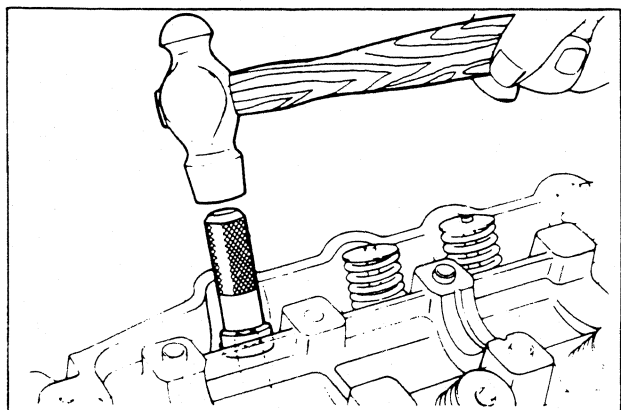
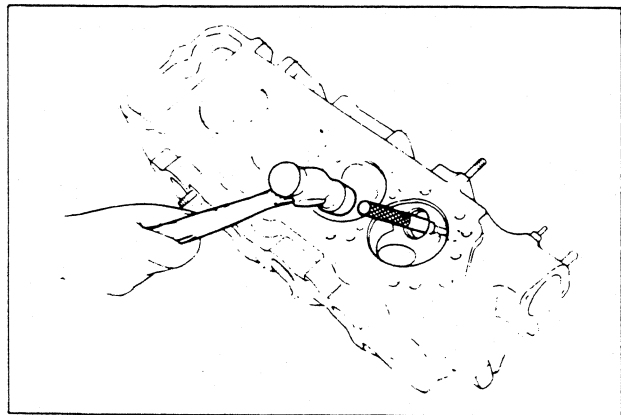

Checking the Valves

1. Check the contact surface of the valve face and valve seat for damage. Minor or rough surface damage may be repaired with a valve grinder.
2. If the valve stem is worn, damaged, bent or the end surface of the stem is dented, replace the valve.
3. Check the valve stem diameter with a micrometer; if the wear exceeds the limit, replace the valve.
4. Check the thickness of the valve head (margin) and diameter. Replace it if it's less than the specified limit.

Minimum valve head thickness: 1.0 mm (0.00394 in).

Limit of reduction in diameter:

Intake: 7.980 mm (0.3142 in).

Exhaust: 7.975 mm (0.3140 in).

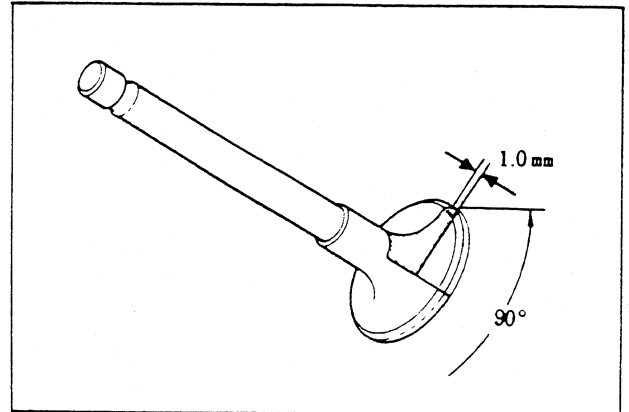
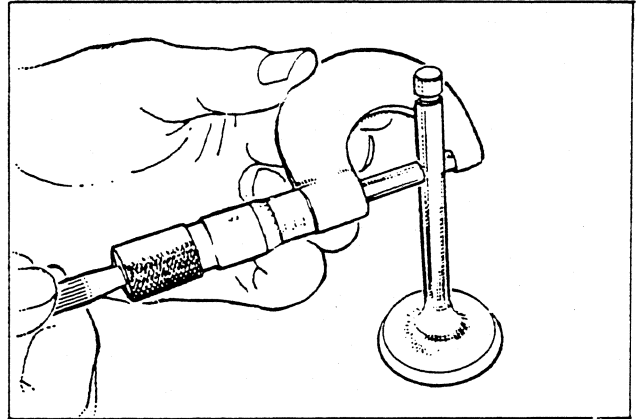

Checking the Valve Springs

1. Check the valve spring for corrosion or damage and replace it if necessary.
2. Check the spring length and replace the spring if the free length is less than the following dimensions.

8.5 BTG and 12.5 BTG

Free length limit: 42.0 mm (1.654 in).

15.0 BTG

Inner Spring 35.7 mm (1.406 in).

Outer Spring 39.1 mm (1.539 in).

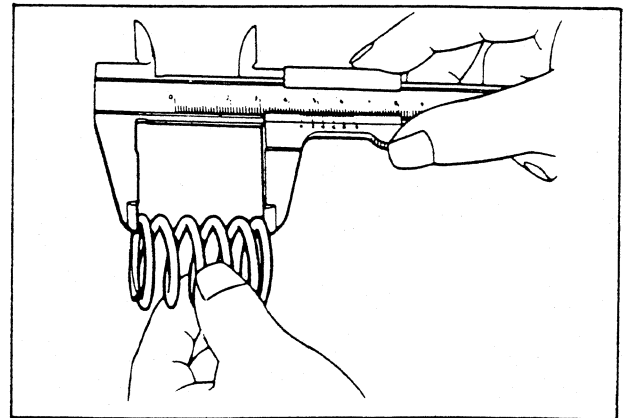

3. Check the squareness of the valve spring. If it exceeds the limit, replace it.

Squareness limit: Less than 3.0 mm (0.118 in) per 100 mm (3.9 in).

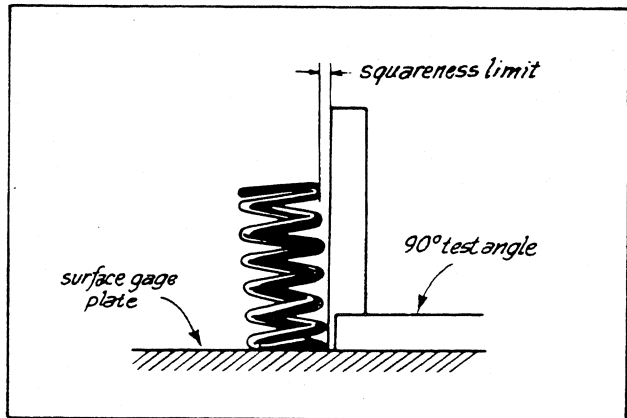

Checking the Valve Seat

1. Check the protruding length of the valve stem (dimension "L"). If it exceeds the specification, correct it as follows.

Dimension "L" (standard): 39.5 mm (1.555 in).

When the dimension "L" becomes 0.5 - 1.5 mm larger than the standard, replace the valve and adjust the dimension "L" to the standard by adding some washers between the lower spring seat and cylinder head.

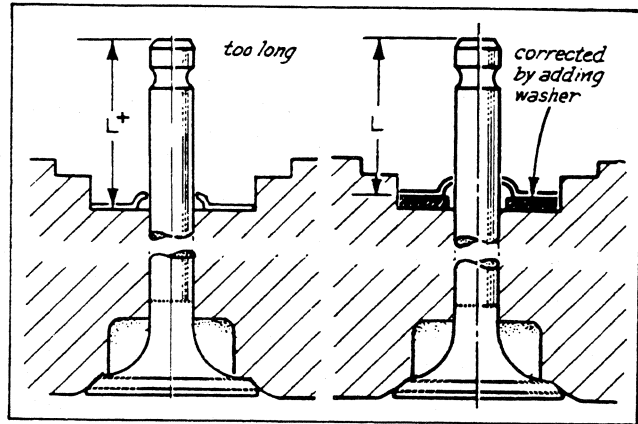

When the dimension "L" becomes more than 1.5 mm larger than the standard, replace both the valve and cylinder head or replace the valve and have a machine shop insert a hardened valve seat to be cut to restore standard "L" length.

2. Check for contact between the valve and valve seat as follows:
 - a. Ensure the clearance between the valve stem and the valve guide is within standards.
 - b. Dress the seat (cut) if needed with a 90° cutter/stone so that the width of surface in contact with the valve is 1.4 mm (0.055 in).
 - c. Apply a thin coat of Prussian Blue (or Redlead) on the valve seat contact face.
 - d. Insert the valve into the valve guide and press fit the valve on the valve seat.
 - e. Check if the valve seat contact face contacts the center position of the valve contact face. If the contact position is not centered, recut and surface the valve seat and valve.

NOTE: Do not rotate the valve.

Refacing the Valve and Valve Seat

Reface in the following order:

1. Reface the valve with a valve grinder to the specified angle.

Valve face angle: 45°

2. Reface the valve seat with a valve seat cutter while checking the contact between the valve and valve seat.

NOTE: Reface the valve seat taking care that the valve seat contacts the center position of the valve.

	Intake	Exhaust
Valve seat angle:	45°	45°
Valve seat width:	1.4 mm (0.055 in)	1.4 mm (0.055 in)

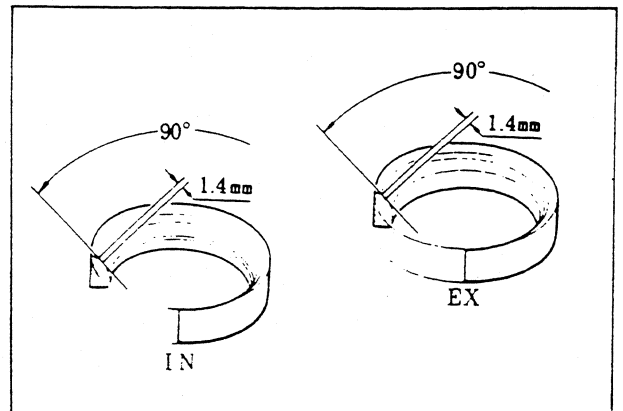
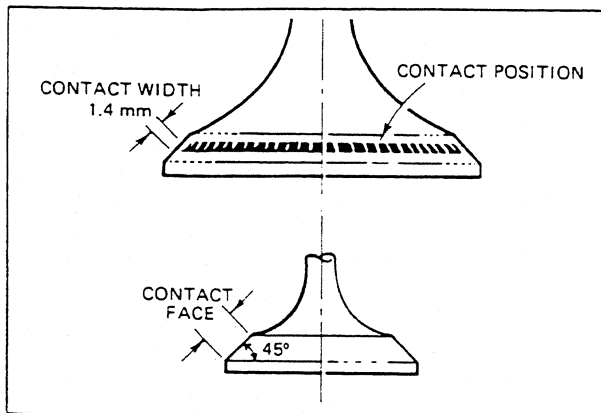

3. Reface the valve and valve seat with a good valve lapping compound.
4. Measure the dimension "L".
5. Adjust the dimension "L" to the standard by adding some washers between the lower spring seat and cylinder head.

Checking the Rocker Arm and Shaft

1. Check each component part of the rocker arm assembly for damage or cracks and, if necessary, replace it.
2. Check to see that the oil passages of the rocker arm and shaft are open. If any clogs are found, remove them or replace.
3. Check the clearance between the rocker arm bore and shaft. If it exceeds the limit, replace the rocker arm bushing and shaft.

Clearance between the rocker arm and shaft:

Rocker shaft diameter: 18.959 - 18.980 mm (0.7464 - 0.7473 in).

Bore in rocker arm: 19.0 - 19.033 mm (0.7480 - 0.7493 in).

Standard clearance: 0.020 - 0.074 mm (0.0008 - 0.0029 in).

Wear limit: 0.10 mm (0.0039 in).

Checking the Cylinder Block

1. Check the cylinder block for damage or cracks. If necessary, repair or replace the cylinder block.
2. Check to see that the oil passages and coolant passages of the cylinder block are open. If they are clogged, remove the obstruction with compressed air or a wire probe.
3. Check the cylinder block for distortion. If it exceeds the limit, repair or replace the cylinder block.

Warp limit: 0.15 mm (0.006 in).

4. Check for scratches or burns on the cylinder walls. If necessary, repair by boring or replace the cylinder block.
5. Measure the wear on the cylinder bores at the six positions shown in the figure with an inside micrometer. (The wear is the difference between the maximum and minimum diameters.) If the wear is more than the specified limit, rebore the cylinder.

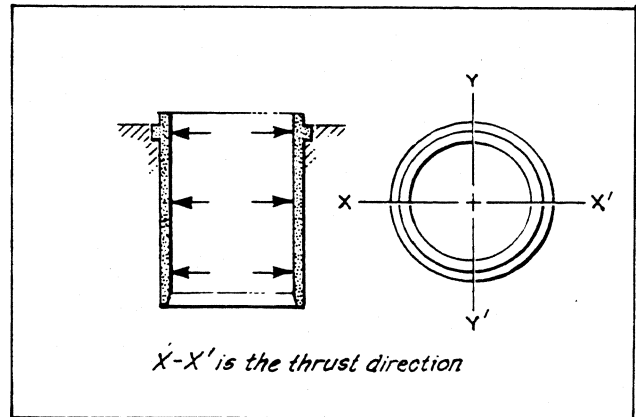
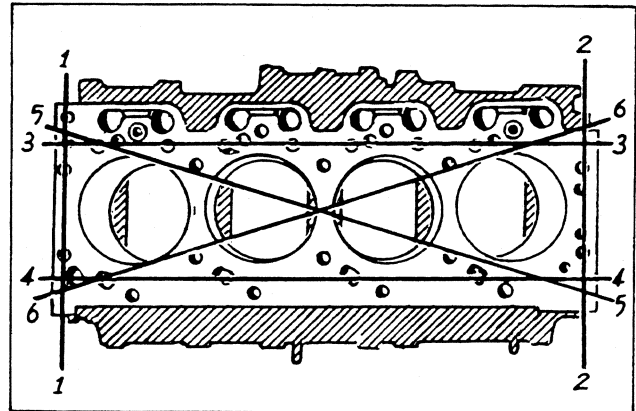

Standard bore diameter:

8.5 KW	70.0 - 70.019 mm (2.7559 - 2.7567 in).
12.5 KW	77.0 - 77.019 mm (3.0315 - 3.0323 in).
15.0 KW	77.0 - 77.019 mm (3.0315 - 3.0323 in).

Maximum difference in bore: 0.15 mm (0.0059 in).

Inner diameter error of each cylinder: 0.09 mm (0.0035 in) or more.

Select oversize pistons according to the maximum wear on the cylinder bore.

- Oversize pistons available:
- 0.25 mm (0.010 in)
 - 0.50 mm (0.020 in)
 - *0.75 mm (0.030 in)
 - *1.00 mm (0.040 in)

*For the 8.5 KW only.

Checking the Pistons

1. Check the pistons carefully and replace them if severe burns or scratches on the external circumference of the piston are found.
2. Measure the piston diameter [18 mm (0.7087 in)] under the oil ring groove at right angles with the piston pin location but without the pin in place.

Standard piston diameter:

8.5 KW 69.944 - 69.964 mm (2.7537 - 2.7545 in)

12.5 KW 76.944 - 76.964 mm (3.0293 - 3.0301 in)

15.0 KW 76.954 - 76.974 mm (3.0297 - 3.0305 in)

3. Check the clearance between the piston and cylinder wall.

Clearance limit: 0.15 mm (0.0059 in).

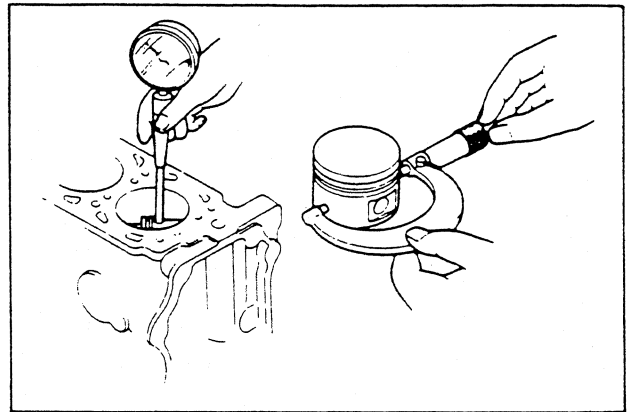
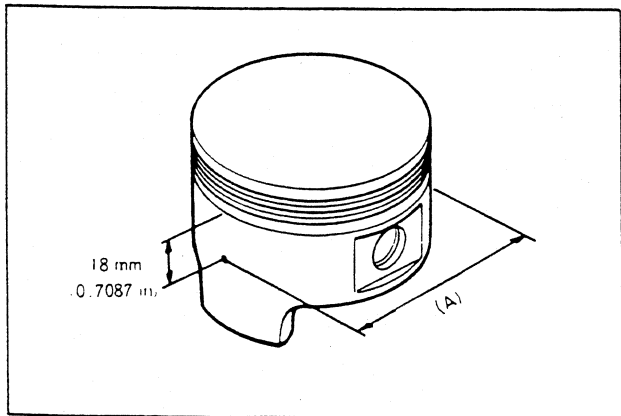

Checking Piston Rings

1. Check the piston rings for cracks, burning or wear, and replace them if necessary.
2. Measure the piston ring end gap. Replace it if it exceeds the limit.

NOTE: Push a ring into the cylinder with a piston until it is about 2 inches from the block surface.

End gap limit: 1.0 mm (0.039 in).

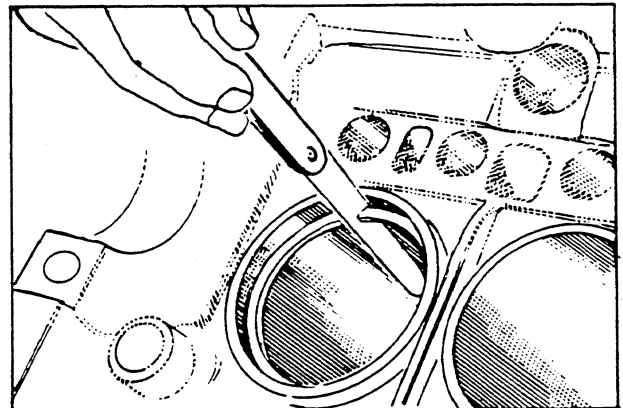

3. Measure the side clearance between the piston ring and ring groove.

NOTE: Measure the clearance around the total circumference of the ring groove.

Side clearance limit: 0.15 mm (0.006 in).

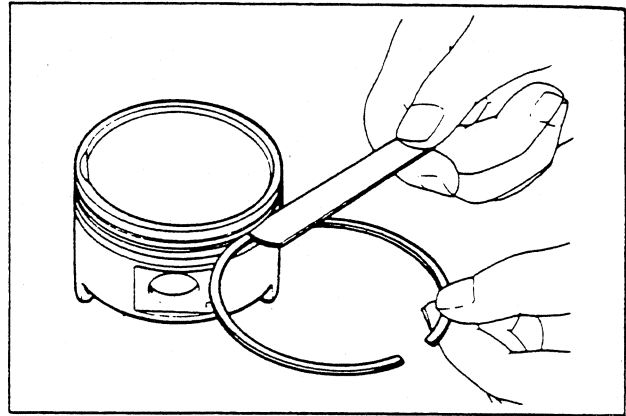

Checking the Connecting Rods

1. Check the side of the connecting rod's small end and large end for cracks or damage. If necessary, replace the connecting rod.
2. Check the connecting rod for bends or twists with a suitable alignment fixture. If realignment is necessary, correct it by using a press and applying a gradual pressure to the rod or replace the connecting rod.

Permissible deflection: 0.04 mm per 100 mm (0.002 in per 3.937 in) or less.

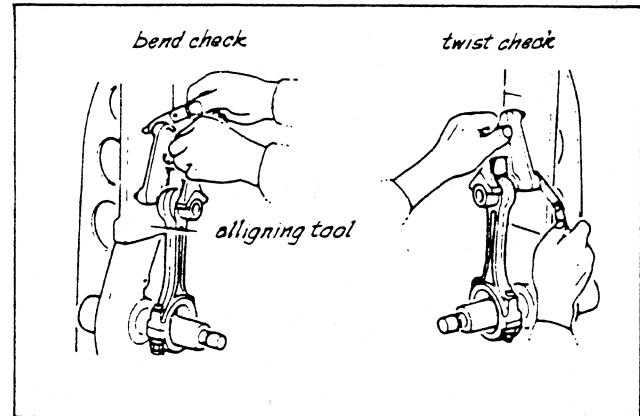

3. Check the connecting rod side play with a dial indicator or a feeler gauge as shown in the figure. If it exceeds the limit, replace the connecting rod or crankshaft.

End play limit: 0.3 mm (0.012 in).

Connecting piston pin bone diameter:

19.948 - 19.961 mm (0.7854 - 0.7859 in).

Clearance between piston pin and piston pin bore:

(-)0.015 - (-)0.040 mm ([-]0.0006 - [-]0.0016 in).

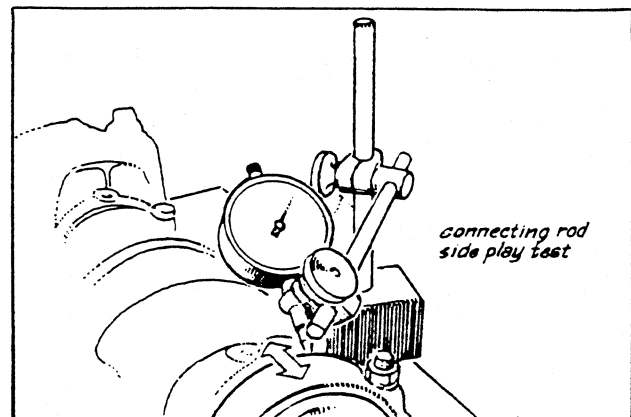

Checking the Connecting Rod Bearings

1. Check the connecting rod bearing carefully and replace it if it is worn, scored or flaked.
2. Check the connecting rod bearing clearance with a "plastigauge". If it exceeds the limit, correct the crankpins with a suitable grinder and use it with suitable undersize bearings.

NOTE: Tighten the connecting rod cap bolts to the specified torque.

Cap tightening torque: 3.0 - 3.5 kg-m (22 - 25 lb-ft).

Bearing clearance:

Standard: 0.024 - 0.048 mm (0.0009 - 0.0019 in).

Limit: 0.10 mm (0.0039 in).

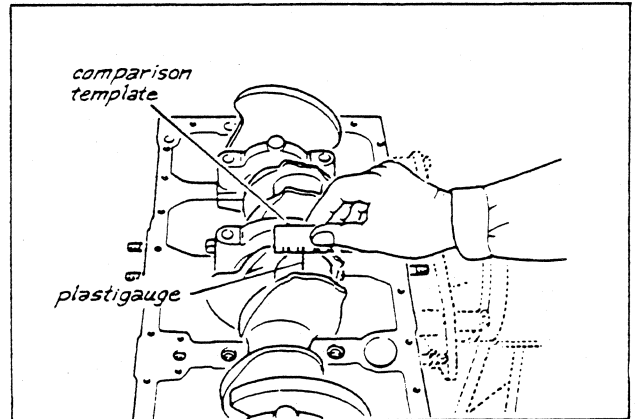

Checking the Crankshaft

1. Check the crankshaft for cracks or other damage and, if necessary, replace the crankshaft.
2. Check to see that the oil passages of the crankshaft are open. If any clogs are found, remove them with compressed air or a suitable wire.
3. Check the crankshaft for wear. If it exceeds the limit, correct the crankshaft with a suitable grinder and use suitable undersize main bearings.

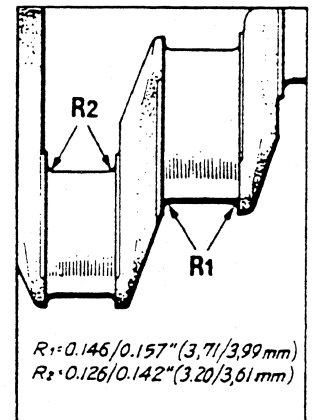
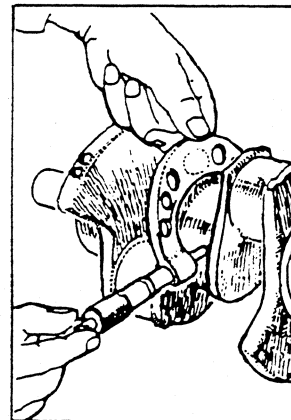

NOTE: Measure the diameter of each of the crankpins and main journals at two points (the front and rear portions) at 90° to the crankshaft axis, as shown in the figure.

	Main Journal	Connecting Rod Journals
Standard	49.938 - 49.956 mm (1.9661 - 1.9668 in)	39.940 - 39.956 mm (1.5724 - 1.5734 in)
Undersize 0.254	49.690 - 49.705 mm (1.9528 - 1.9534 in)	39.690 - 39.706 mm (1.5598 - 1.5604 in)
Undersize 0.508	49.440 - 49.455 mm (1.9430 - 1.9436 in)	39.440 - 39.456 mm (1.5500 - 1.5506 in)
Undersize 0.762	49.190 - 49.205 mm (1.9332 - 1.9338 in)	39.190 - 39.206 mm (1.5402 - 1.5408 in)

NOTE: When grinding the crankshaft, take care of the following items.

- a. When grinding the crankshaft, finish the place of "R" as shown in the figure.
- b. The crankshaft processing diameters are as shown in the table on the preceding page.

4. Check the crankshaft alignment. If it exceeds the limit, replace it.

Maximum allowable run-out:

0.03 mm (0.0012 in).

5. Check the crankshaft end play with a dial indicator as shown in the figure. If it exceeds the limit, replace the thrust bearing with an oversized thrust bearing.

End play standard: 0.10 - 0.15 mm
(0.004 - 0.006 in).

NOTE: Any crankshaft grinding should be done by a qualified machine shop.

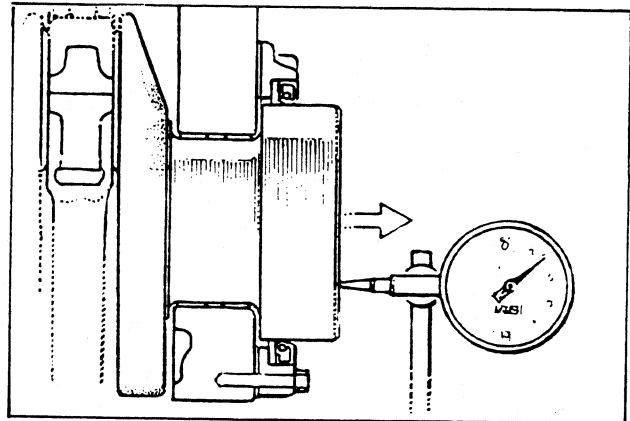
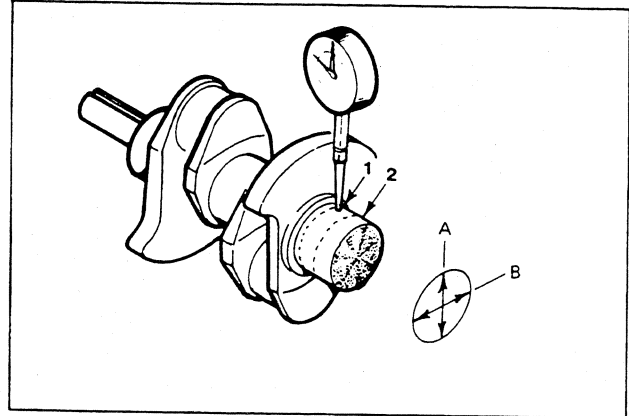

Checking the Main Bearing

1. Check the main bearing carefully and replace it if it is worn, scored or flaked.
2. Check the main bearing clearance with a "plastigauge". If it exceeds the limit, correct the main journals by having the crankshaft ground for undersized main bearings.

NOTE: Tighten the main bearing cap bolts to the specified torque.

Bearing clearance:

Standard: 0.023 - 0.042 mm
(0.0009 - 0.0017 in).

Limit: 0.08 mm (0.0031 in).

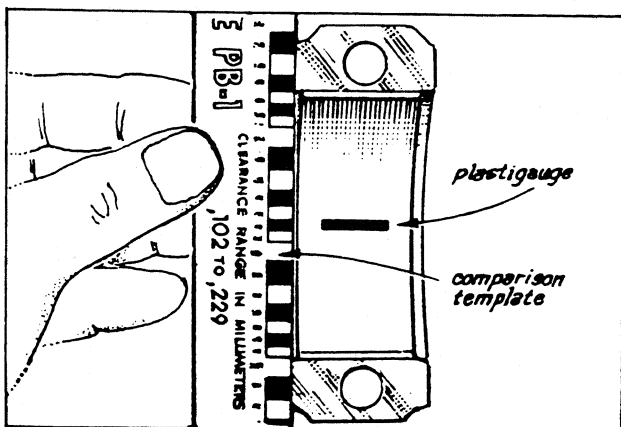

Checking the Camshaft

1. Check the camshaft for cracks, wear or damage and replace it if necessary.
2. Measure the run-out. If it exceeds the limit, replace the camshaft. Measure runout at the center bearing journal.

Limit of runout: 0.03 mm (0.0012 in).

3. Measure the cam lobe height and replace it if the wear exceeds the limit.

Cam lobe height:	Standard	Limit
8.5 KW	44.119 mm (1.7401 in)	43.919 mm (1.7291 in)
12.5 KW	44.114 mm (1.7337 in)	43.914 mm (1.7258 in)
15.0 KW	44.114 mm (1.7337 in)	43.914 mm (1.7258 in)

4. Measure the extent of uneven wear on the journals at four locations (direction A and B, front and back). Replace it if the limit is exceeded.

Maximum wear limit: 0.05 mm (0.002 in).

Diameter of journal (standard):

Front and rear: 41.949 - 41.965 mm
(1.6515 - 1.6522 in).

Center: 41.919 - 41.935 mm
(1.6504 - 1.651 in).

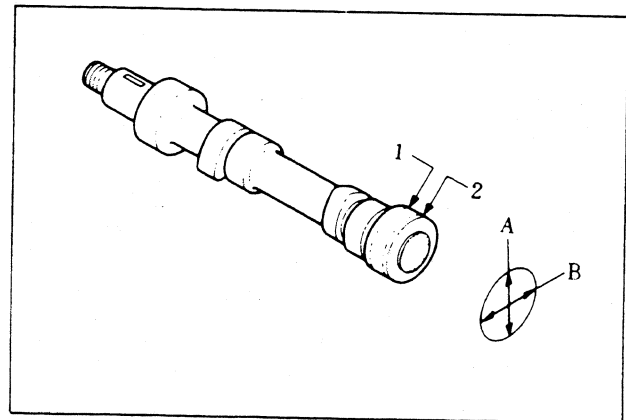
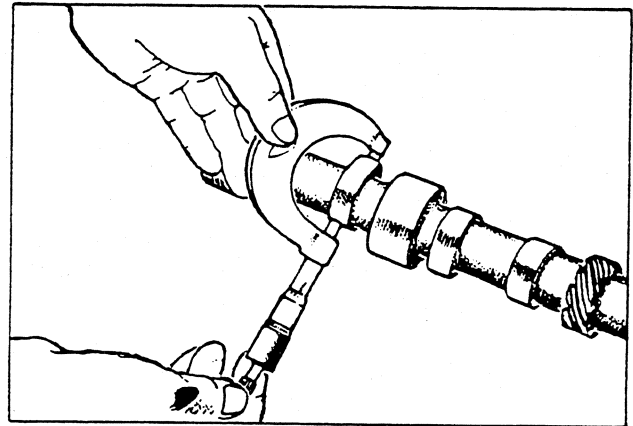

Checking the Flywheel and Ring Gear

1. Check the flywheel for damage or wear on the ring gear tooth surface and replace it, if necessary.
2. Replace the ring gear using the following procedure:
 - a. Heat the ring with a torch.
 - b. Remove the ring gear by striking its circumference.
 - c. Heat the new ring gear to 250 - 300° C (480 - 570° F) on a hot plate or in an oven. Before slipping it onto the flywheel, make sure that the chamfered side of the ring gear is directed toward the engine.

NOTE: Excessive heat may destroy original heat treatment and cause premature failure of the ring gear.

Checking the Chain, Chain Adjuster Blade, Damper and Sprocket

1. Check for wear or damage and replace any faulty parts.

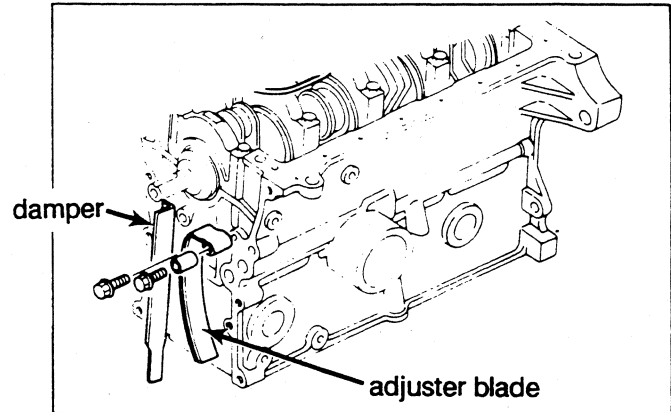
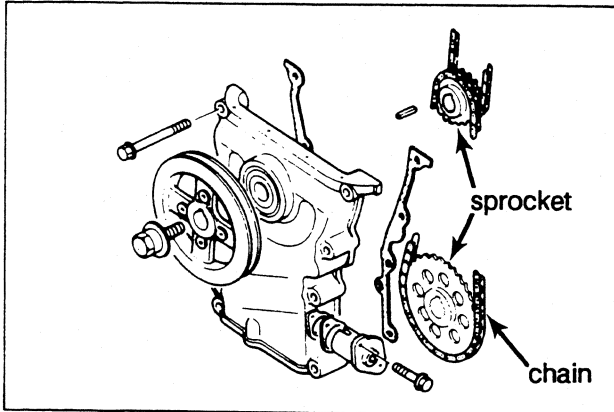

ENGINE ASSEMBLY

Take the following precautions:

- A. Make sure that all parts to be assembled are thoroughly cleaned.
- B. Be careful not to mix nuts and bolts. Metric and S.A.E bolts are used on various engine assemblies.
- C. During assembly, recheck clearances and make sure parts are being assembled in their proper order and facing in the correct direction in relation to the engine block, e.g., pistons, piston rings, bearings, and bearing caps.
- D. Apply lubrication oil to moving parts during assembly. Make sure that moving parts, when assembled on the engine, rotate or slide and are not subject to binding or excessive tension.
- E. If there are mating marks scribed during disassembly, reference them correctly for assembly.
- F. Use new gaskets, lockwashers, o-rings, ext.
- G. Tighten the bolts and nuts on important parts of engine to specified torques using a reliable torque wrench.
- H. Use liquid sealants when required on nuts, bolts and gaskets. Refrain from using tape sealants.

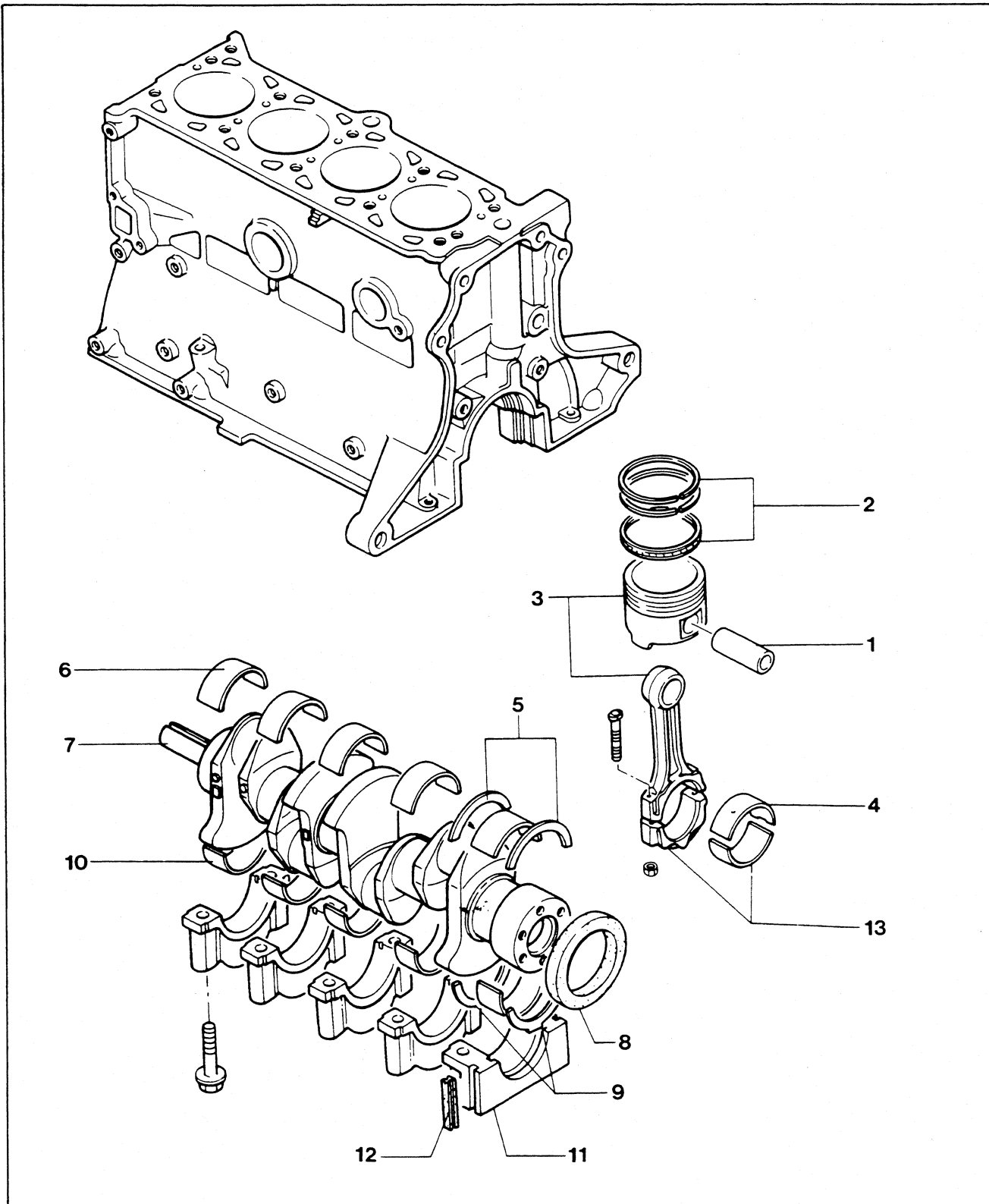

- | | | |
|------------------------------|-------------------|------------------------------------|
| 1. Piston pin | 6. Main bearing | 11. Main bearing cap |
| 2. Piston ring | 7. Crankshaft | 12. Side seal |
| 3. Piston and connecting rod | 8. Oil seal | 13. Connecting rod bearing and cap |
| 4. Connecting rod bearing | 9. Thrust washers | |
| 5. Thrust washers | 10. Main bearing | |

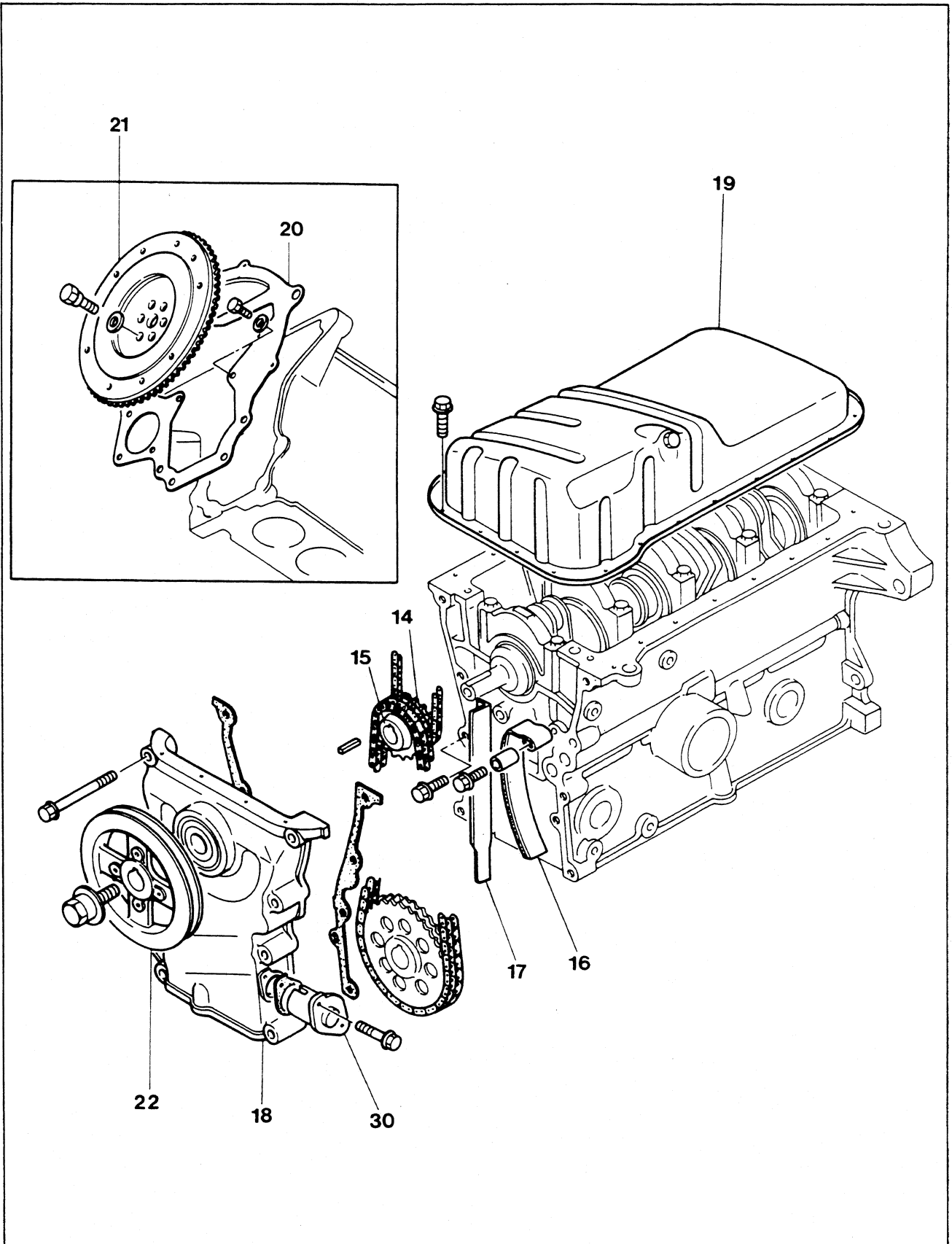

14. Oil pump chain and sprocket
 15. Timing chain and sprocket
 16. Adjuster blade

17. Chain damper
 18. Timing chain cover
 19. Oil pan

20. End plate
 21. Flywheel
 22. Crankshaft pulley

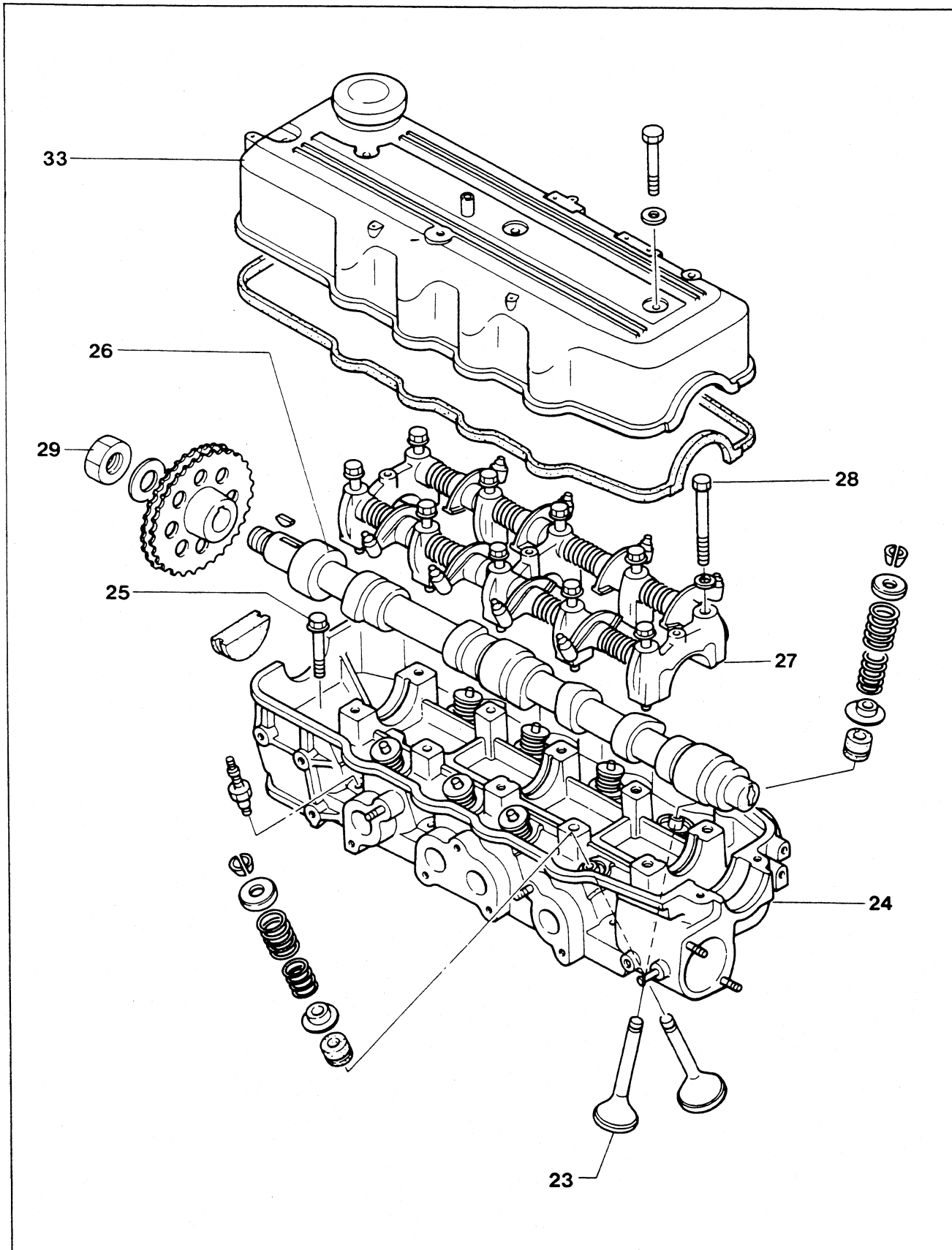

- 23. Valve
- 24. Cylinder head
- 25. Bolt (cylinder head - timing chain cover)

- 26. Camshaft
- 27. Rocker arm
- 28. Cylinder head bolt
- 29. Locknut (camshaft sprocket)

- 30. Chain adjuster

1. Assemble the pistons and connecting rods according to the following procedure. Use a piston setting tool.

a. Assemble as shown in the figure.

NOTE: Observe the positioning of the "F" on the piston and the dimple mark on the rod when assembling

b. Apply engine oil to the external circumference of the piston pins.

c. Set the special tool and the piston pin as shown in the figure.

d. Press fit by pressing the top end of the installer. The piston pin is in the specified position when the lower end of the guide touches the bottom of the block. The pressing load is 500 - 1500 kg (1100 - 3300 lbs). Replace the piston pin or connecting rod if the pressing load is less or more than shown.

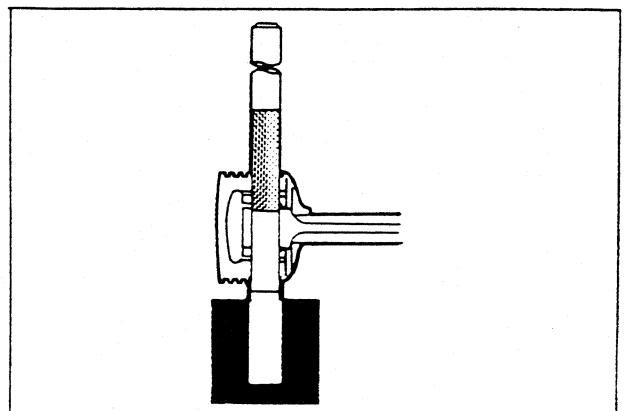
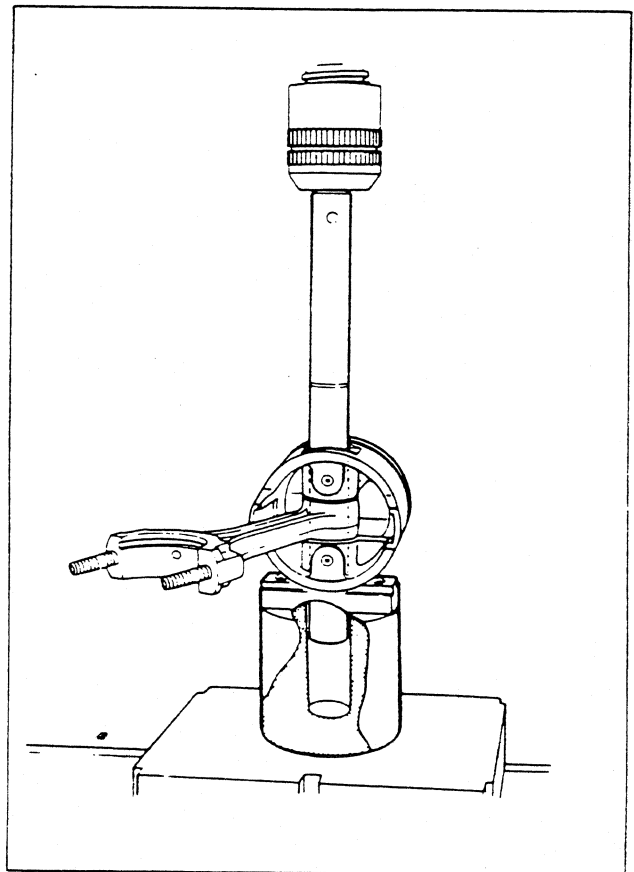
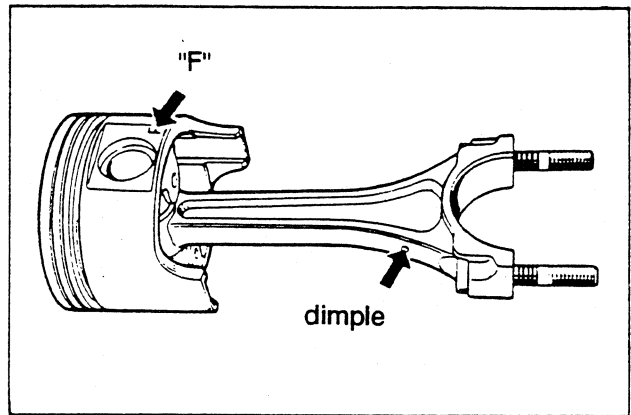

2. Assemble the piston rings using a suitable piston ring expander.
 - a. Install both rings (second and top rings) with "R" mark on the top surface.
 - b. Set the open end of each ring in the positions shown in the figure.

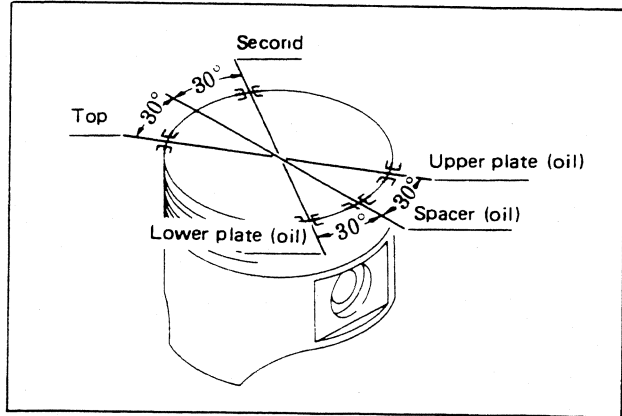
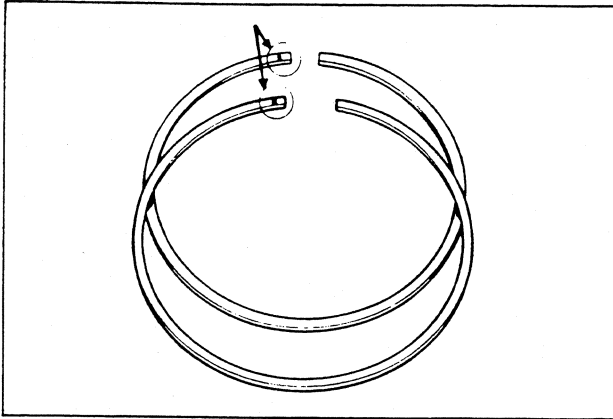

3. Insert the piston into the cylinder block. Make sure the "F" mark stamped on the piston is facing toward the crankshaft pulley end (engine front). Use a suitable piston ring compressor.

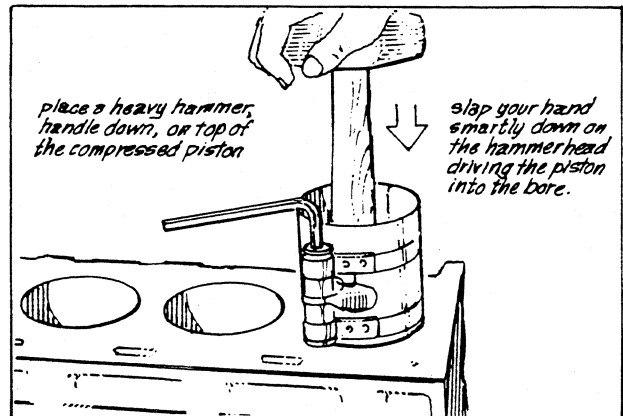
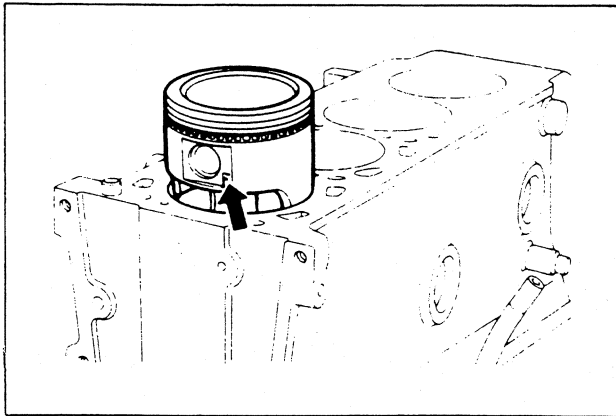

4. Insert the main bearings on the block and make sure the bearing oil ports are properly aligned.
5. Install the upper thrustwashers with the groove in the washer being directed outward (crankshaft thrust side).
6. Crankshaft. Be careful that the thrustwashers do not drop as the crankshaft settles in place.

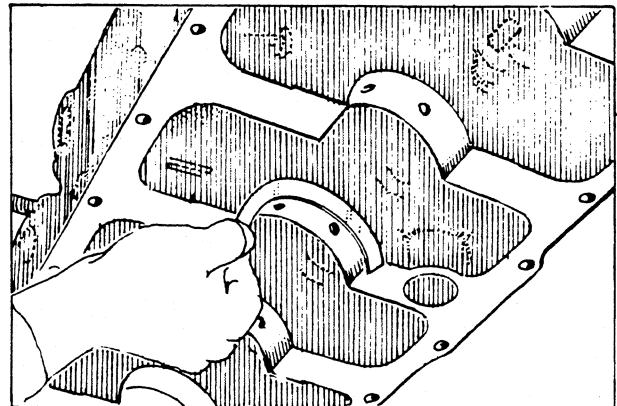

7. Rear oil seal.

8. Install the lower thrustwashers with the groove in the washer being directed outward.

9. Insert the lower main bearings.

10. Main bearing caps.

NOTE: Match the main bearing cap with the "Cap No." and the arrow mark should point towards the front of the engine.

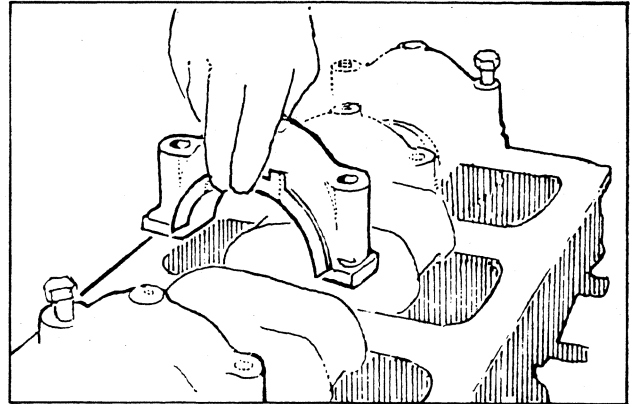

11. Tighten the main bearing cap bolts.

NOTE: Make sure the crankshaft rotates smoothly after installation.

Cap bolt tightening torque: 6.6 - 7.1 kg - m (48 - 51 lb - ft).

12. Insert the side seal. Make sure that the hole in the seal is pointed either toward the inside or outside of the cylinder block.

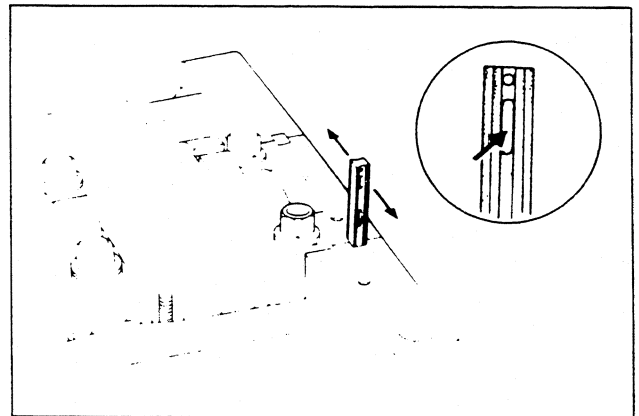

13. Connecting rod caps.

NOTE: Apply engine oil onto the surface of the connecting rod bearings prior to installing. Make sure the rod caps are properly matched to the proper rod.

14. Connecting rod cap bolts.

Tightening torque: 3.0 - 3.5 kg - m (22 - 25 lb - ft).

NOTE: Rotate the crankshaft one revolution after installing and torquing each connecting rod.

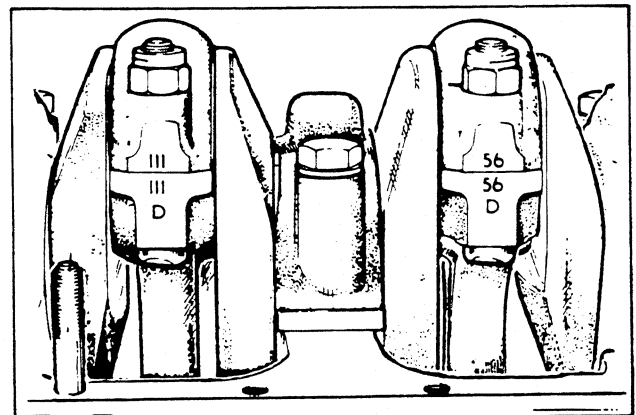

15. Install the oil pump with the drive chain on both the crankshaft and oil pump sprocket.

16. Timing chain and sprockets.

a. Match the ring plate mark (shiny link) of the timing chain with the timing mark of the crankshaft sprocket.

b. Install the crankshaft sprocket on the crankshaft. Be sure not to change the assembled position of the timing chain and sprocket.

c. Match the other shiny marked link to the camshaft sprocket. Tie the chain and sprocket together with wire so the assembled position of the timing chain and camshaft sprocket is not changed.

17. Timing chain adjuster blade.

18. Timing chain damper.

19. Timing chain front cover.

NOTE: Cut off any excess portions of the cover gasket at both ends.

Tightening torque: 1.9 - 3.1 kg - m (14 - 22 lb-ft).

20. Oil pan. Use a good sealant between the surfaces of the gasket. Torque oil pan bolts 0.7 - 1.2 kg/m (5.1 - 8.7 ft/lb).

21. Backplate.

Tightening torque: 7 - 10 kg-m (51 - 72 lb-ft).

22. Flywheel.

NOTE: Install the flywheel by placing it on the crankshaft and rotating it to properly align the mounting bolt holes. Install the tabwasher and mounting bolts. After torquing, bend one tab against a flat of each of the mounting bolts.

Tightening torque: 8.3 - 9.0 kg-m (60 - 65 lb-ft).

23. Front crankshaft pulley. Apply sealant to the threads of the crankshaft pulley bolt and torque.

Tightening torque: 11.0 - 12.0 kg-m (80 - 87 lb-ft).

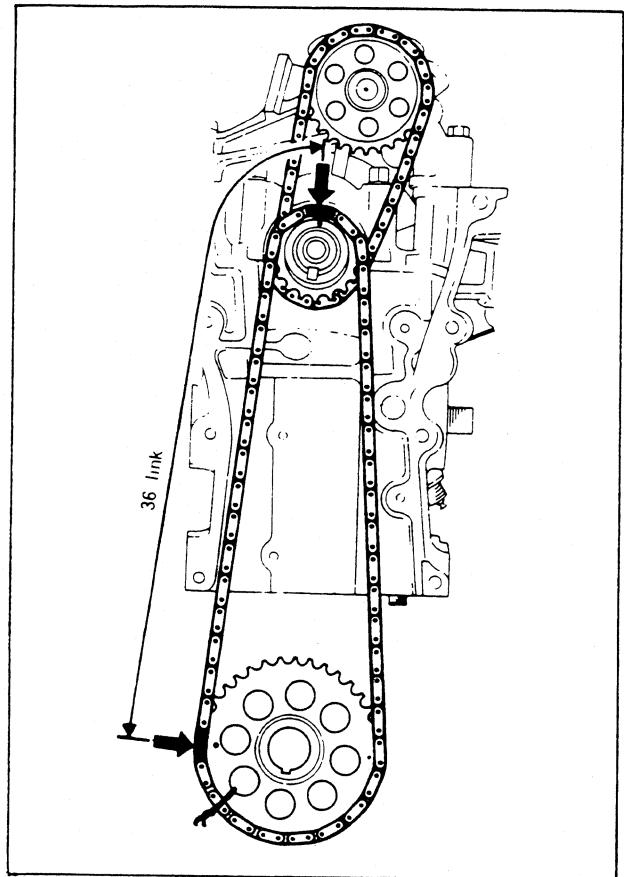

24. Valves. Assemble the valves in the cylinder head with a valve spring lifter and pivot.

NOTE: Install correct keepers on intake and exhaust valves

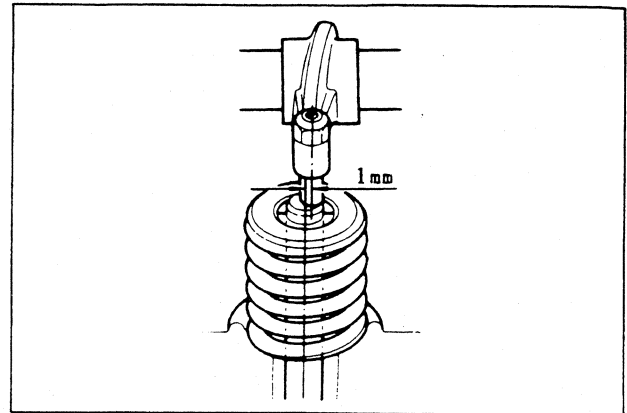

25. Cylinder head.

- Position the head gasket on the block.
- Position the cylinder head and install the rocker shaft assembly. Note the arrows on supports face the front of the engine.
- Install the capscrew through the head into the timing chain cover.

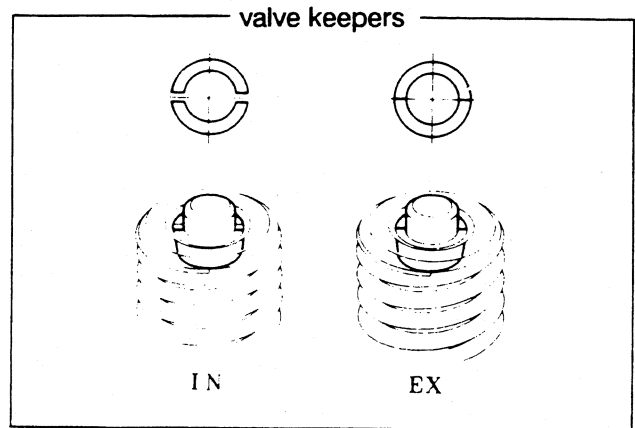

26. Camshaft.

- Slide the timing chain sprocket on the camshaft making sure the position of the chain and the timing mark on the sprocket are correct.
- Position the camshaft on the cylinder head.

27. Rocker shaft assembly. Install the valve rocker arms on the rocker arm shaft. Make sure there is 1 mm (.039 in) of offset between the center of the rocker arm adjusting screw and that of the exhaust valve stem.

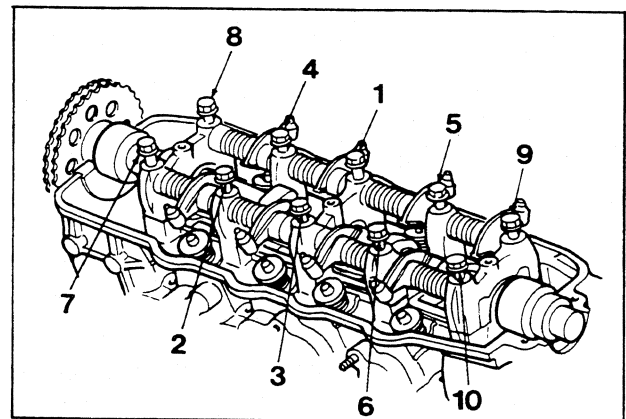

28. Cylinder head bolts.

NOTE: Tighten the cylinder head bolts in the order shown in the figure.

Tightening torque: 7.8 - 8.2 kg-m (56 - 59 lb-ft) (when cool).

29. Check the oil clearance between the camshaft and cap with a "plastigauge".

NOTE: Make sure head bolts are properly torqued after checking the oil clearance.

Limit of camshaft oil clearance: 0.15 mm (0.0059 in).

30. Install the camshaft drive sprocket washer and nut.

Tightening torque: 7.0 - 8.0 kg-m (51 - 58 lb-ft).

31. Check the camshaft end play (clearance between sprocket and thrust plate). If the end play exceeds the specified limit, replace the thrust plate.

Limit of camshaft end play: 0.20 mm (0.008 in).

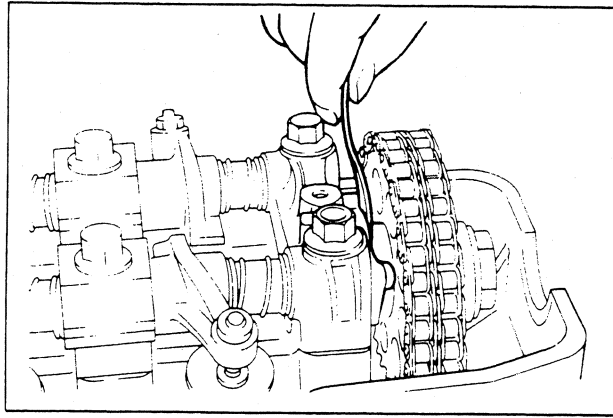

32. Timing chain tension adjuster. Install the chain adjuster on the timing chain cover according to the following procedure.

- a. Push the sleeve into the body completely and lock it with the pin and hook.
- b. Install the chain adjuster.

NOTE: After the adjuster is installed, the pin is released by the action of the timing chain which is actuated when the engine is cranked once or twice and the sleeve projects automatically, thus applying tension to the camshaft drive chain.

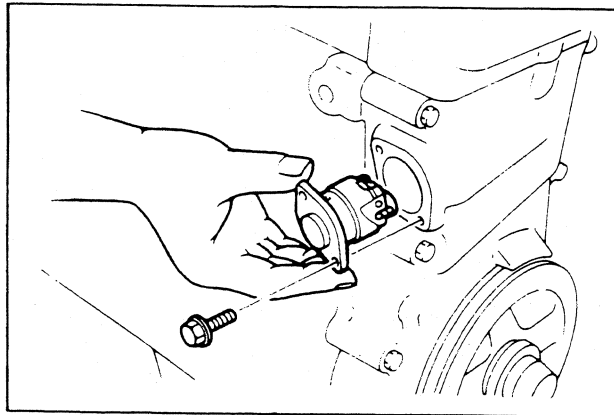
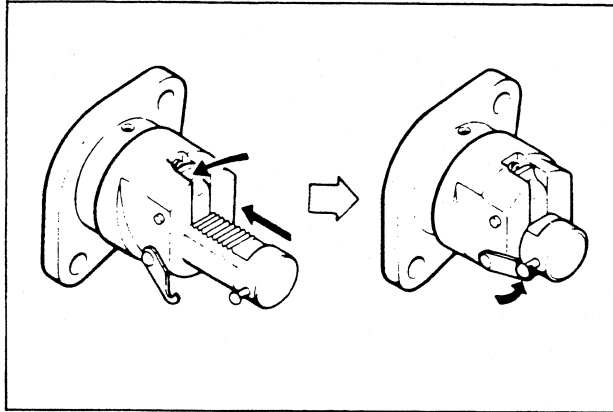

33. Distributor.

- a. Turn the crankshaft until the piston in the No. 1 cylinder reaches the top dead center of the compression stroke. Make sure that the mark on the crankshaft matches the top mark (T) on the timing chain cover.
- b. Apply engine oil sparingly to the o-ring fitted on the distributor shaft. Make sure the rotor is pointing toward the No. 1 spark plug high tension lead terminal.

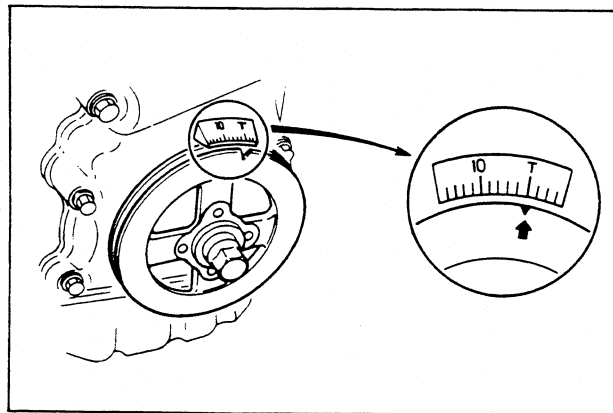

- c. Insert the distributor shaft by turning it, making sure the distributor shaft fits into the groove on the rear end of the camshaft. This groove is offset so the distributor can only be installed correctly to the camshaft.

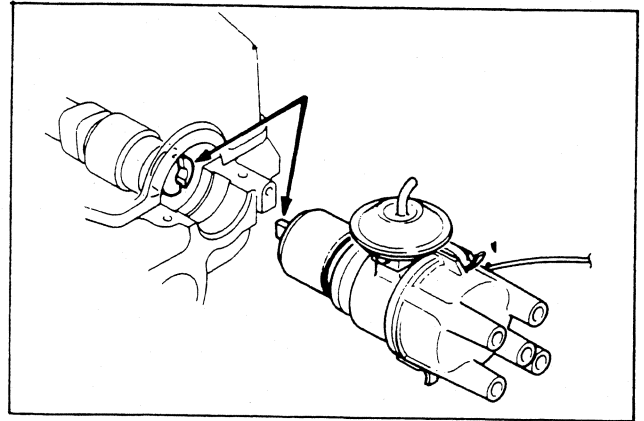
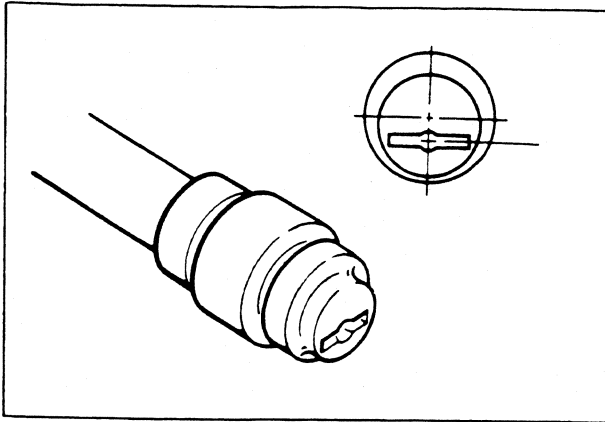

34. Adjust the engine timing according to specifications in the "System Specifications" section.

- 35 Adjust the valve clearance.

- a. Adjust the valve exhaust #1 and #3 and intake #1 and #2 with the piston at the top dead center of the compression stroke of No. 1 cylinder.
- b. Rotate the crankshaft 360° and adjust the remaining valves.

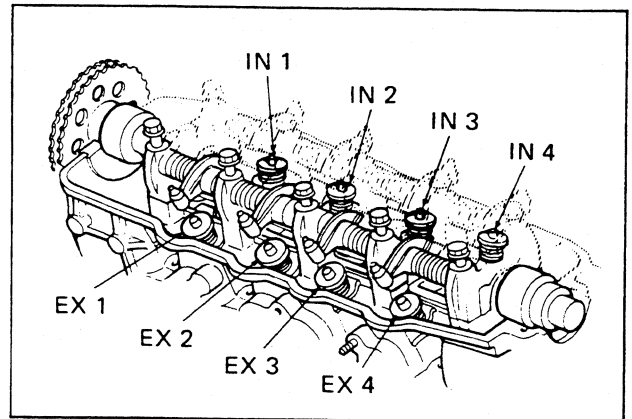

	Intake Valve	Exhaust Valve
Valve side	0.25 mm (0.010 in)	0.30 mm (0.012 in)
Cam side	0.18 mm (0.007 in)	0.23 mm (0.009 in)

36. Thermostat.

NOTE: Be sure to position the thermostat with the bleed hole at 12 o'clock. Make sure the thermostat body is inboard of the block. Install the thermostat housing.

37. Oil filter.

NOTE: Apply engine oil sparingly to the o-ring of the oil filter and tighten the filter fully by hand.

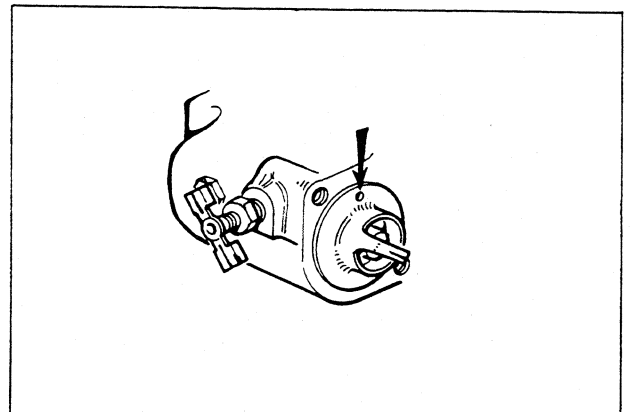

Reinstall the following:

- 38. Rocker cover.
- 39. Oil manifold tee, oil pressure sender and switch.
- 40. Fresh water pump.
- 41. Bell housing.
- 42. Ignition coil and bracket.
- 43. Intake manifold.

Tightening torque: 1.9 - 2.6 kg-m (14 - 19 lb-ft).

- 44. Carburetor and fuel pump with connecting fuel line. Use new line and fittings if the line will not seal at its connection points.
- 45. Alternator and bracket.
- 46. Governor.
- 47. Sea water pump.
- 48. Starter motor and circuit breaker.
- 49. Heat exchanger and related hoses.
- 50. Exhaust manifold assembly and related hoses.

Tightening torque: 1.9 - 2.3 kg-m (14 - 17 lb-ft).

- 51. Armature and drive disc assembly.

Tightening torque:

Drive disc to armature: 6.9 - 7.6 kg-m (50 - 55 lb-ft).

Drive disc with cooling fan to flywheel: 2.5 - 2.8 kg-m (18 - 20 lb-ft).

- 52. Carefully position the generator stator housing over the armature. Ensure the carrier bearing fits snugly in the housing. Bolt the stator housing to the engine back plate.
- 53. Check AC electrical leads and reconnect to the generator AC terminal block. Protect leads exiting the generator housing from chaffing.
- 54. Check the wiring harness in the generator control panel and on the engine. Make sure the harness is connected to the correct terminals in the panel and components on the engine.
- 55. Mounts and rails.

56. Adjust the "V" belt tension.

"V" belt deflection exerting 10 kg (22 lbs) force:

For new belt: 9 - 11 mm (0.35 - 0.43 in).

For used belt: 10 - 12 mm (0.39 - 0.47 in).

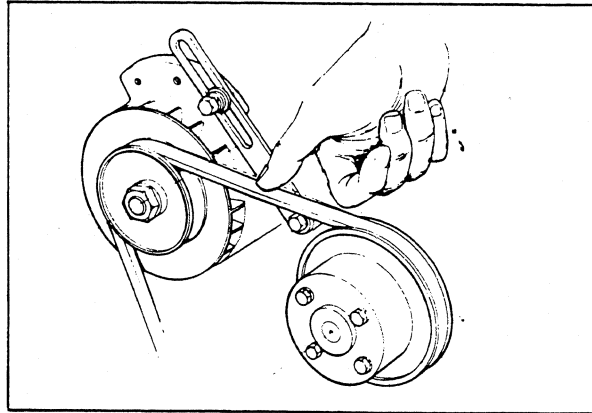

NOTES

LUBRICATION SYSTEM

Operation

The lubricating system is a pressure feeding system using an oil pump. The engine oil forced out of the oil pump is passed through the oil filter, then to the various lubricating points in the engine and returned to the lubrication oil sump.

When the oil pressure exceeds the specified pressure, the oil pushes open the relief valve in the oil pump and returns to the oil pan, thereby keeping the oil pressure within its specified range.

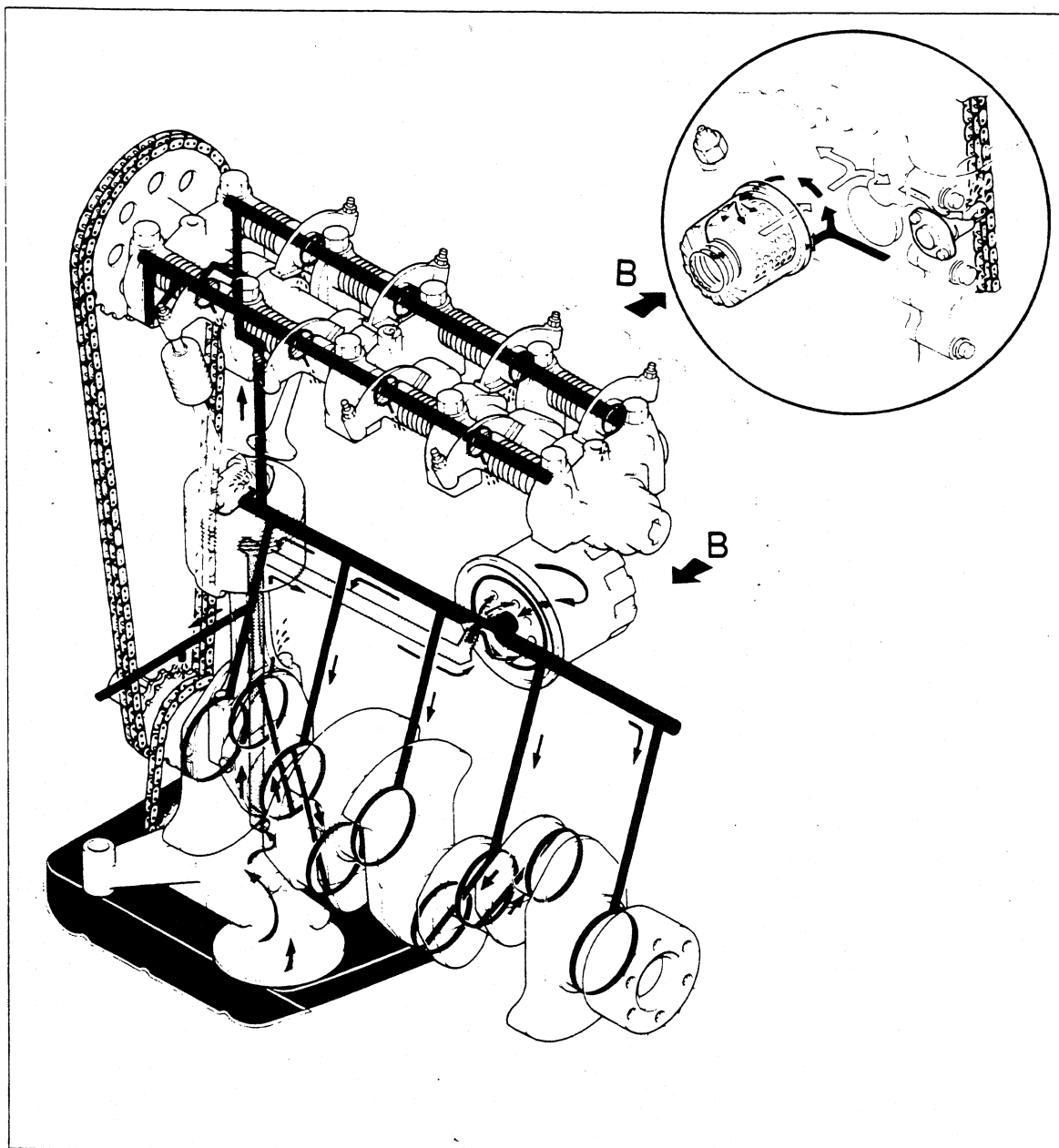

Checking the Engine's Lubricating Oil

1. Check for any engine oil leakage. Should an oil leak be detected, inspect the engine to locate the leak and correct it. Tightening of fittings and bolts is considered normal maintenance and is the responsibility of the owner.
2. Check engine's oil level with the oil dipstick at least once daily prior to engine usage. Add oil as needed.
3. Make sure the engine's oil level is maintained near, but not over, the **F** mark on the dipstick. If the engine's oil drops close to the **L** mark, add the engine oil until the oil level reaches the **F** mark. Keep an eye on the engine's oil level. After the engine is broken in, if the engine continues to consume a noticeable quantity of engine oil, consult a competent marine mechanic.

NOTE: Maintaining the engine's oil level with the proper lubricating oil and making sure that the oil is changed at the proper intervals is the responsibility of the owner/operator. Engine damage resulting from the lack of engine oil, from the wrong type of oil, or from unclean oil is **not** a warrantable issue.

Engine oil capacity:
(not including filter)

8.5 KW BTG	3.9 U.S. quarts (3.7 liters)
12.5 KW BTG	3.9 U.S. quarts (3.7 liters)
15.0 KW BTG	3.9 U.S. quarts (3.7 liters)

Troubleshooting the Oil System

<u>Trouble</u>	<u>Possible Cause</u>	<u>Remedy</u>
Oil leak	1. Loose oil drain hose.	1. Tighten or replace.
	2. Oil pan to cylinder block leakage.	2. Tighten securing belts or replace pan gasket.
	3. Damaged or loose timing chain cover or rocker cover.	3. Replace or tighten bolts.
	4. Damaged or loose cylinder head gasket.	4. Tighten or replace.
	5. Loose or damaged oil filter.	5. Tighten or replace.
	6. Loose or damaged pressure switch or sender.	6. Tighten or replace.

Trouble

Low Oil Pressure
(unit shutdown)

Possible Cause

1. Oil leaks.
2. Low oil level or incorrect grade.
3. Faulty oil pressure switch.
4. Clogged oil filter.
5. Clogged oil pump strainer.
6. Worn or fatigued oil pressure relief valve spring.
7. Faulty electrical circuit.

Remedy

1. Refer to above.
2. Add oil to proper level or change.
3. Test and replace.
4. Remove and replace oil filter.
5. Remove and clean.
6. Remove and replace.
7. Check circuit and repair as needed.

Checking Oil Pressure with a Mechanical Gauge

1. Remove the oil pressure sender and connect a mechanical oil pressure gauge in its place.
2. Electrically jump the oil pressure switch's connections.
3. Start the engine, letting it operate at 1800 rpm, and allow engine to warm up.
4. Measure the oil pressure. If it is less than the specification listed below, check the engine's lubricating system.

Oil pressure: 25 - 35 psi
(1.75 - 2.50 kg/cm²)

NOTE: Ensure that the engine's oil meets all temperature requirements and the API specification of SD, SE, SF, or SG.

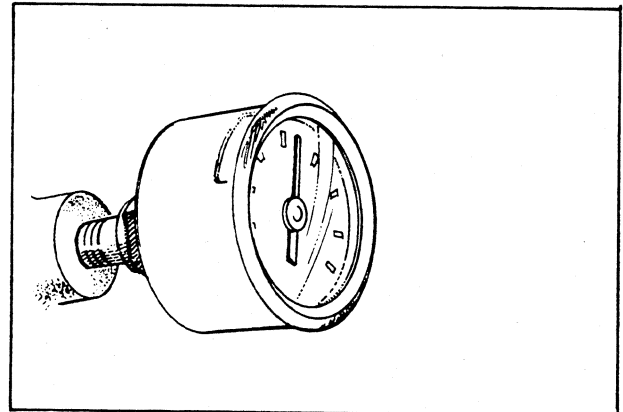

COOLING SYSTEM

Description

Westerbeke marine gasoline engines are designed and equipped for fresh water cooling. Heat produced in the engine by combustion and friction is transferred to the fresh water which circulates throughout the engine. This circulating fresh water cools the engine block and its internal moving parts. The heat is transferred externally from the fresh water to sea water by means of a heat exchanger, similar in function to an automotive radiator. Sea water flows through the tubes of the heat exchanger while fresh water flows around the tubes; engine heat transferred to fresh water is conducted through the tube walls to the sea water which is pumped into the exhaust system and discharged overboard. In basic terms, the engine is cooled by fresh water, the fresh water is cooled by sea water, and the sea water carries the transferred heat over the side through the exhaust system. The fresh water and sea water circuits are independent of each other. Using only fresh water within the engine allows the cooling water passages to stay clean and free from harmful deposits. The two independent circuits and their components are discussed in the following paragraphs.

Fresh Water Circuit

Fresh water is pumped through the engine by a belt-driven circulating pump, absorbing heat created by internal combustion and by friction. The fresh water coolant circulates throughout the engine block absorbing heat, then passes through the thermostat into the exhaust manifold, then to the heat exchanger where it is cooled, and then is returned to the engine block through the suction side of the fresh water circulating pump. When the engine is started cold, external fresh water flow is prevented by the closed thermostat (although some fresh water flow is bypassed around the thermostat to prevent the exhaust manifold from overheating). As the engine warms up, the thermostat gradually opens, allowing the engine's fresh water coolant to flow unrestricted to the external portion of the cooling system.

Sea Water Circuit

The sea water flow is created by a positive displacement neoprene impeller pump. Normally, the pump draws sea water directly from the ocean through a flush-hull sea cock and sea water strainer. Sea water then flows directly from the discharge of the sea water pump to the heat exchanger sea water inlet. After passing through the tubes of the heat exchanger, the sea water enters a water injected, wet exhaust system, the most popular type of exhaust system in use. In the case of larger engines, the sea water flow is divided prior to entering the exhaust systems so that a portion is used to cool the exhaust system. Full sea water flow would create unnecessary exhaust back pressure.

Sea Water Pump

The sea water pump is self priming and positive displacement. This rotary sea water pump has a non-ferrous housing and a neoprene impeller. The impeller has flexible vanes which wipe against a curved cam plate within the impeller housing, producing a pumping action. **On no account should this pump be run dry.** There should always be a spare impeller and impeller cover gasket aboard (an impeller kit).

Zinc Anodes

A zinc anode, or pencil, is located in the sea water cooling circuit within the heat exchanger. The purpose of the zinc anode is to sacrifice itself to electrolysis action taking place in the sea water cooling circuit, thereby reducing the effects of electrolysis on other components of the system. The condition of the zinc anode should be checked monthly and the anode cleaned or replaced, as required. Spare anodes should be carried on board.

NOTE: Electrolysis action is the result of each particular installation and vessel location; not that of the generator.

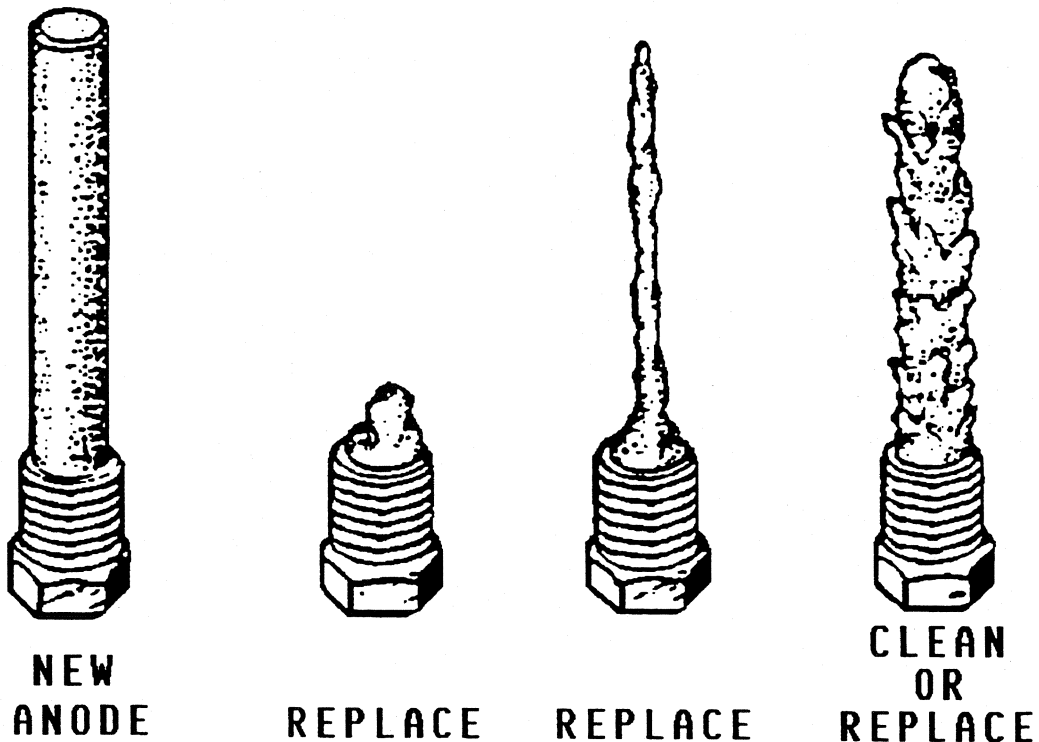

If the zinc pencil needs replacement, **hold the hex boss into which the zinc pencil is threaded with a wrench while loosening the anode with another wrench.** This prevents the hex boss from possibly tearing off the exchanger shell. After removing the zinc, note the condition of it. If the zinc is in poor condition, there are probably a lot of zinc flakes within the exchanger. Remove the end of the heat exchanger and clean the inside of all zinc debris. **Always have a spare heat exchanger end gasket in case the present one becomes damaged when removing the end cover.** Replace the gasket (refer to your engine model's heat exchanger end gasket part number), cover, and install a new zinc pencil.

Fresh Water Pump Removal

1. Drain coolant from engine block.
2. Remove pump drive belt by loosening the 12 volt alternator adjusting strap and pivot bolt.
3. Remove coolant hose from pump to manifold.
4. Remove belts mounting pump to engine block and remove pump.

Checking the Fresh Water Pump

1. Check for water leaks. Replace cover gasket, cover, or pump as necessary.
2. Replace pump if abnormal noise or bearing squeak is present.
3. Examine pump and impeller for damage and replace if necessary.

Sea Water Pump Impeller Replacement

The following instructions are general and indicative only. Specific instructions where applicable may be packaged with your replacement impeller.

1. Remove the front cover gasket.
2. Remove the impeller by pulling straight outwards, parallel to the pump shaft. This is best done with a pair of pliers applied to the impeller hub.
3. Coat the replacement impeller and the chamber into which it mounts with grease.
4. Carefully align the impeller keyway or other locking mechanism with the shaft. Take care that all the impeller blades bend in the same direction and trailing.
5. Inspect the front cover for wear. A worn front cover should ultimately be replaced. Sometimes it can be reversed as an emergency measure, but not when stamped markings would break the seal between the cover and the impeller blades.
6. Reinstall the end cover with a new gasket.
7. Be sure to check quickly for sea water flow when starting the engine. The absence of flow indicates that the pump may not be priming itself properly. This situation *must* be investigated immediately or damage to the new impeller will result from overheating.

Sea Water Pump Removal

1. Remove inlet and outlet hoses connected to nipples on pump. Note connections on pump for proper assembly.
2. Loosen bolt's mounting pump to support bracket and remove drive belt.

3. Remove mounting nuts and bolts and lift pump from engine.

Raw Water Pump Disassembly

Disassemble in the following order.

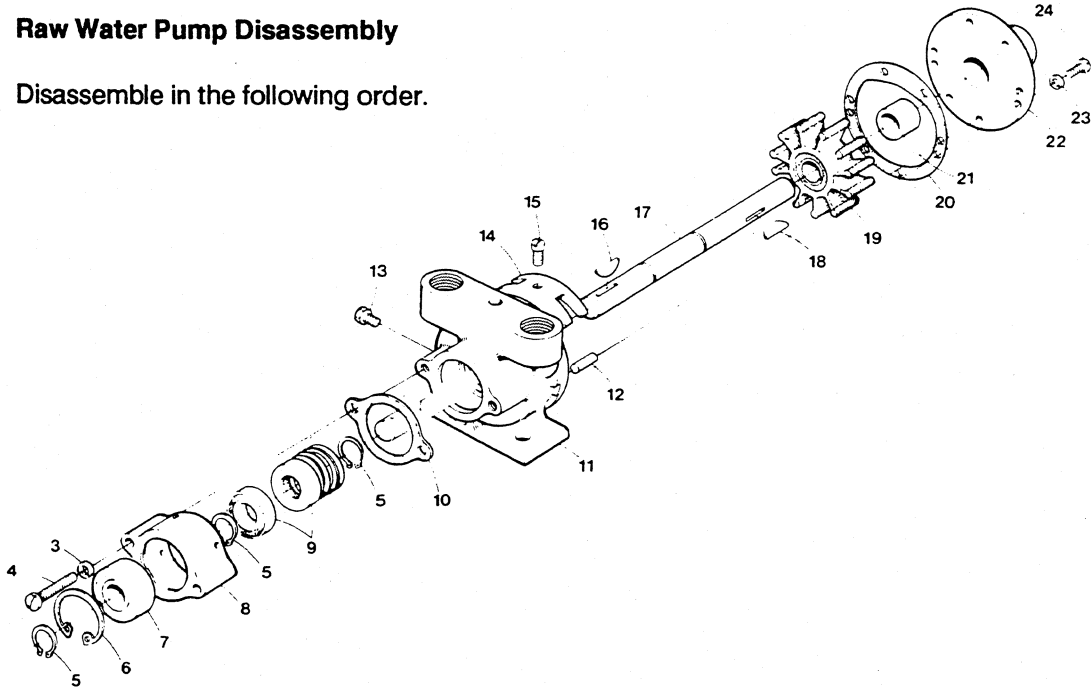

1. Impeller cover with graphite bushing, screws, lockwashers, and gasket (ref. 20 -24).

2. Impeller and key (ref. 18 -19).

3. Drive pulley and key (ref. 16).

4. Bearing housing, screws, and lockwashers.

NOTE: Shaft #17 withdrawn through the front of the pump with the bearing housing, bearing, and seal assembly (ref. 5 - 10).

5. Cam and screw (ref. 14-15).

6. Small retaining ring and seal (ref. 5 - 10).

7. Large retaining ring (ref. 6).

8. Bearing housing (ref. 8) from shaft and bearing.

9. Small retaining rings (ref. 5).

10. Bearing (ref. 7).

11. Drain plug and dowels (ref. 12 - 13).

NOTE: Drive pulley not shown.

Thermostat Removal

The thermostat is mounted inside a housing on the back of the cylinder head next to the distributor.

1. Drain the coolant.
2. Remove the hose from thermostat housing to heat exchanger.
3. Remove thermostat cover housing and bolts.
4. Remove thermostat.
5. Remove housing gasket.

Checking Thermostat

A thermostat can be checked for proper operation by placing it in a pan of cold water and then raising the temperature of the water to a boil. The thermostat should open noticeably (with travel on the order of 1/4" - 1/2") and be fully opened when the water is boiling.

Thermostat installation

1. Install in reverse order using a new housing gasket coated on both sides with gasket cement.

NOTE: Insure that the small vent hole in the thermostat is at the 12 o'clock position when the thermostat is installed.

2. Replenish the coolant, start the engine, and check that there are no leaks.

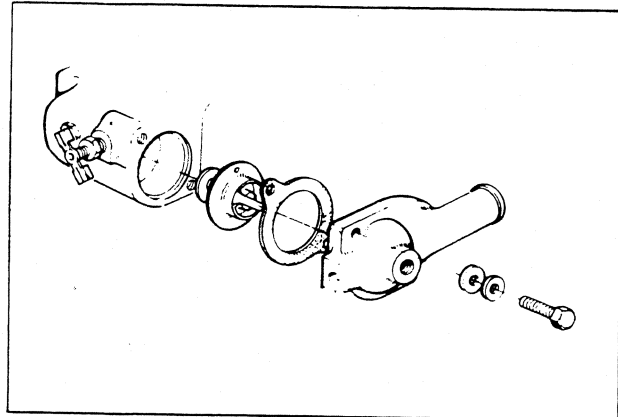

Engine Coolant

It is recommended that an antifreeze mixture be used in the engine fresh water cooling system. Use an antifreeze that is compatible with aluminum engine components. The mixture should be according to the manufacturer's instructions. Rust and scale inhibitors should be added if not found in the antifreeze used.

Filling and Draining the Fresh Water System

Draining system coolant - Two points on the engine fresh water cooling system should be opened to drain fresh water coolant from the engine block, manifold, and exchanger.

Point #1 - Remove drain plug located on the right inboard side of the engine heat exchanger.

Point #2 - Remove the hose connected to the inlet of the fresh water circulating pump.

Filling the system with coolant -

1. Replace the inlet hose to the fresh water circulating pump and close the drain plug on the heat exchanger.
2. Fill system with antifreeze mixture through the filler neck on the exhaust manifold until the coolant is 1/4 - 1/2 inch from the filler neck.
3. Start the engine and add coolant to maintain the level at the filler neck. As the engine reaches operating temperature, air is expelled from the system and the coolant starts to circulate.
4. With engine at operating temperature, fill manifold completely and install pressure cap. Add coolant to plastic recovery tank until level is between **MIN** and **MAX**. Monitor coolant level from recovery tank. Add coolant as needed. Should an extreme loss of coolant be found, investigate cause before further engine operation.
5. Correct the coolant leak and repeat steps 2 - 4.

Exhaust Manifold Removal

Removal of the exhaust manifold from the engine should be done as a complete assembly in the following manner.

1. Drain the engine and cooling system of all coolant.
2. Remove the exhaust connection.
3. Loosen and remove all hose connections to the manifold.
4. Loosen and remove the nuts and bolts attaching the manifold assembly to the cylinder head.
5. Remove the manifold from the cylinder head as a complete unit.

Exhaust Manifold Servicing

1. Remove the exhaust elbows from the lower surface of the manifold. Clean and inspect for cracks and defects. Replace as needed.
2. Remove exhaust nipples, elbows and plugs from the manifold.
3. Remove water connectors from the ends of the manifold and the end plates. Be sure to note the proper location and arrangement of each for proper replacement.
4. Examine all parts for defects, corrosion, and wear. Replace as needed.

Exhaust Manifold Installation

1. If the manifold was removed as an assembly and left intact, it can be replaced on the cylinder head in the reverse order of removal. **Do not** reuse the gaskets; install new ones and torque the bolts or nuts to the proper specification (14 - 19 lb/ft).

2. If the manifold has been disassembled, follow the steps below.

- a. Loosely attach the elbows to the cylinder head and the manifold using new gaskets. **Do not** use any gasket sealant.
- b. Gradually tighten each fitting to make sure of proper alignment of all the parts. This should be done in three steps. Torque to 14 - 19 lb/ft.
- c. Reassemble the end plate's connectors on the manifold. Be sure to use new gaskets and coat the gasket surfaces with a suitable gasket cement such as "High Tack." Torque the nuts to 8 - 10 lb/ft.
- d. Reinstall the exhaust connections and plug into the manifold using "Loctite-Anti-Seize" on the threads.
- e. Reconnect all hoses, replacing them as needed.
- f. Refill the system with coolant as detailed above.
- g. Pressure test system and check for leaks.

Adjust "V" Belt Tension

"V" belt deflection exerting 10 kg
(22 lbs) force:

For new belt: 9 - 11 mm
(0.35 - 0.43 in.)

For used belt: 10 - 12 mm
(0.39 - 0.47 in.)

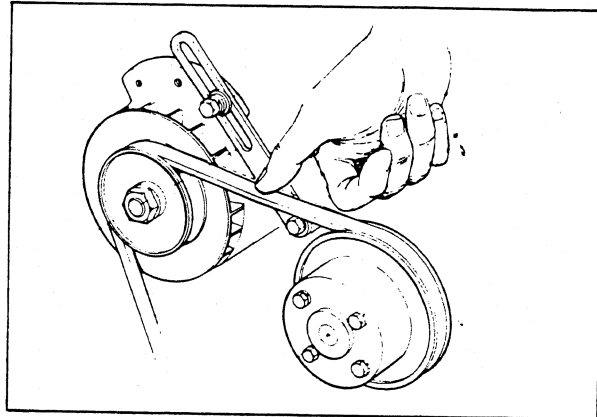

Cooling System Troubleshooting

<u>Trouble</u>	<u>Possible Cause</u>	<u>Remedy</u>
Coolant leaks: It is recommended that when trying to locate a leak in the cooling system that the system be pressure tested using a commercially available pressure tester such as the STANT #ST255. Follow instructions with the tester. Locate and correct the leak.	1. Leaking pressure cap.	1. Test with above unit and/or replace.
	2. Faulty plastic coolant recovery tank.	2. Check and tighten connections or replace tank.
Overheating (Fresh Water System)	1. Insufficient coolant.	1. Replenish coolant and check for cause of loss.
	2. Loose or broken water pump drive belt.	2. Adjust or replace.
	3. Faulty thermostat.	3. Remove and replace.
	4. Faulty overheat switch.	4. Remove and replace.
	5. Scale and sediment in cooling system.	5. Flush engine cooling system and heat exchanger replenish coolant.
	6. Faulty circulating pump.	6. Remove and replace.
Overheating (Sea Water System)	1. Loose or broken sea water pump drive belt.	1. Adjust or replace.
	2. Faulty sea water pump.	2. Check sea water pump for wear, defective impeller. Repair or replace as needed.
	3. Clogged heat exchanger.	3. Remove exchanger, clean and flush.
	4. Scale in exhaust..	4. Remove elbow and clean.

Other causes of engine overheating may be caused from faults in the sea water circuit supplying coolant to the sea water pump on the engine. Examine the off circuit for possible contributing faults.

GOVERNOR

Governor Description

The belt-driven, mechanically operated governor maintains the engine's rpm under various load conditions. Engine speed determines the hertz and voltage output of the generator.

NOTE: Periodically adjust the governor's belt tension. The belt's tension should be between 3/8 to 1/2 inch deflection between the widest span of this belt. Since belts stretch slightly, this stretching will, to some degree, affect the governor's action. Maintain a 22 pound pressure to the belt's outer face for proper governor operation. Replace this drive belt when it becomes worn, frayed or cracked.

CAUTION

Do not over tighten the governor's drive belt. Over tightening causes premature wear of the governor, the belt, or could bend the governor's shaft.

The governor will maintain engine speed to within 3 hertz of generator frequency output from no-load to full rated load of the generator. (See the generator's red and silver Data Plate.)

Governor Adjustments

Operate the generator set to bring the unit up to its operating temperature before attempting an adjustment.

NOTE: If the governor is severely out of adjustment, manually adjust the linkage without any load on the generator to obtain a safe output voltage before proceeding with the adjustment.

Three adjusting points are on the governor. (Refer to the illustration below.)

1. **Bumper Screw** This screw is used to remove a no-load surge **only**. **Never** turn the bumper screw into the governor far enough so that it increases the no-load speed. To adjust the governor, turn the bumper screw in until the engine stops surging. Now bring the idle screw (on the carburetor) up until the generator runs at 60 cycles no-load. Apply a 1/4, a 1/2 and a 3/4 load to the generator.

NOTE: Only if the generator surges at any of these load intervals are you to follow steps 2 and 3 that follow.

2. **Increase/Decrease Speed** This adjusting bolt sets the no load speed of the engine. (The linkage arm between the governor arm and throttle lever should be adjusted to hold the throttle full open when the engine is not running.) Make sure this linkage moves freely and that the ball joint connectors are properly lubricated. Use graphite lubricant at this connection. Disconnect the ball joint and apply a graphite lubricant to the inside of the joint.

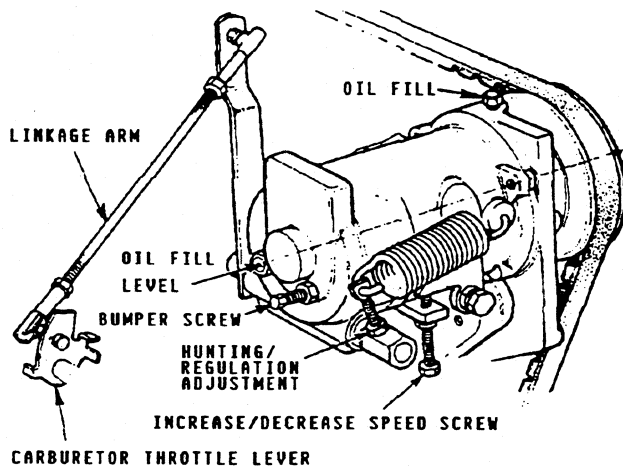

3. Hunting/Regulation If the variation in engine speed between no-load and full-load is too great, adjust this eye bolt to draw the spring closer to the lever hub. The increase/decrease speed bolt may need to be adjusted as well.

If the governor surges while under a load, adjust this eye bolt to move the spring away from the lever hub. (Check the speed adjustment.)

Governor Maintenance

1. Periodically lubricate the attaching points at both ends of the governor arm. Use a graphite lubricant or an equivalent.

NOTE: Free movement of this linkage arm is important for proper governor/throttle operation.

2. Governor oil capacity - 3 ounces (.09 liters) of SAE #10/30 motor oil.

NOTE: Do not overfill the governor.

(Use of synthetic oil is recommended)

3. Change the governor's oil every 500 hours of operation.
4. The drive belt should be maintained in good condition. Replace the belt if it becomes worn or shows signs of cracking.

To change the oil, remove the governor from engine and remove the oil fill and fill level plug and drain all the oil from the governor. Reinstall the governor on the engine and fill it with 3 ounces (.09 liters) of SAE 10/30 engine oil. Replace the plugs.

CARBURETOR AND FUEL SYSTEM

Carburetor

The carburetor is a single barrel down draft type with a metal screened air intake filter which is cleanable. The carburetor has two metering jets, one of which is adjustable (the idle mixture). The other fast running jet is set at the factory and will accept no adjustment. Any adjustment to the idle mixture jet should be done with the engine warmed up and without any load on the generator.

Carburetor Adjustment

1. Idle Mixture Jet

Disconnect the throttle linkage arm from the governor control arm and reduce the engine's speed with the idle stop screw. Turn the idle mixture screw clockwise (in) until the engine skips; back the screw out (counterclockwise), slowly, until the engine smooths then skips again; then turn the screw clockwise (in) one-quarter to one-half of a turn. The idle mixture should be satisfactory at this setting.

2. Run Mixture Jet

This mixture jet is presized at the factory and is not adjustable. The idle mixture jet adjustment can be made in the 1800 rpm range to improve engine performance. Refer to the "Governor Adjustments" section of this manual for instructions on how to adjust the engine's speed, page 106.

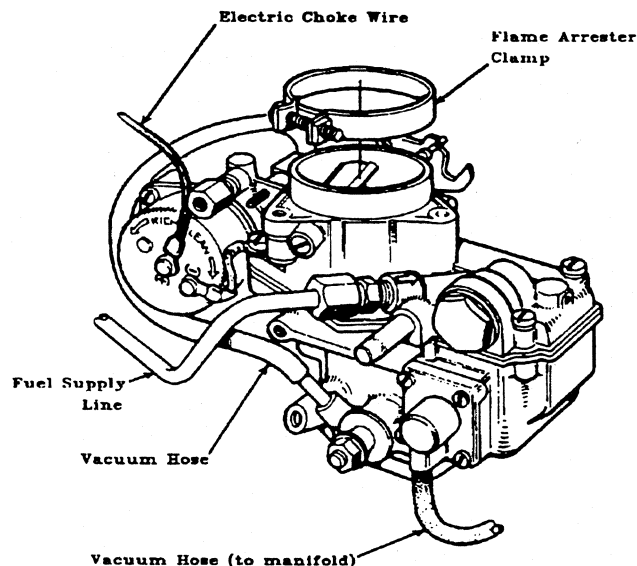

Carburetor with flame arrester removed.

Disassembling and Rebuilding the Carburetor

To rebuild the carburetor, first purchase a carburetor rebuilding kit. Make sure that the rebuild kit contains all of the following rebuild parts. Refer to the illustration below the list.

Two (2) copper accelerator pump gaskets

One (1) needle valve and seat (two pieces to the set)

One (1) throttle shaft valve spring

One (1) aluminum seat gasket

One (1) idle mixture screw O-ring

One (1) accelerator pump diaphragm/gasket

One (1) choke lever spring

One (1) main body gasket

One (1) rotary throttle shaft valve

One (1) manifold gasket

One (1) fuel filter element

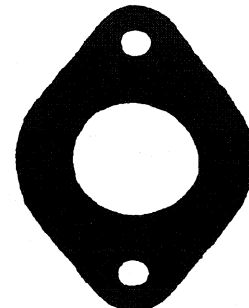
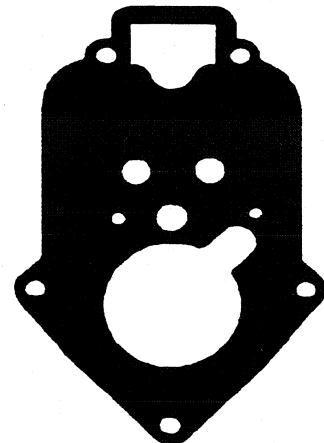
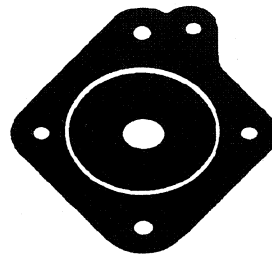
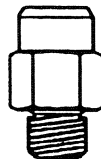
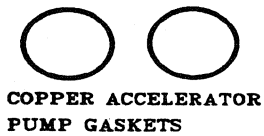

1. Loosen the flame arrester clamp and remove the flame arrester (not shown). Disconnect the electric choke wire, the vacuum hose attached to the manifold, the fuel supply line, and the throttle control linkage (see bottom drawing).

2. Remove the two nuts holding the carburetor to the manifold and lift the carburetor from the manifold.

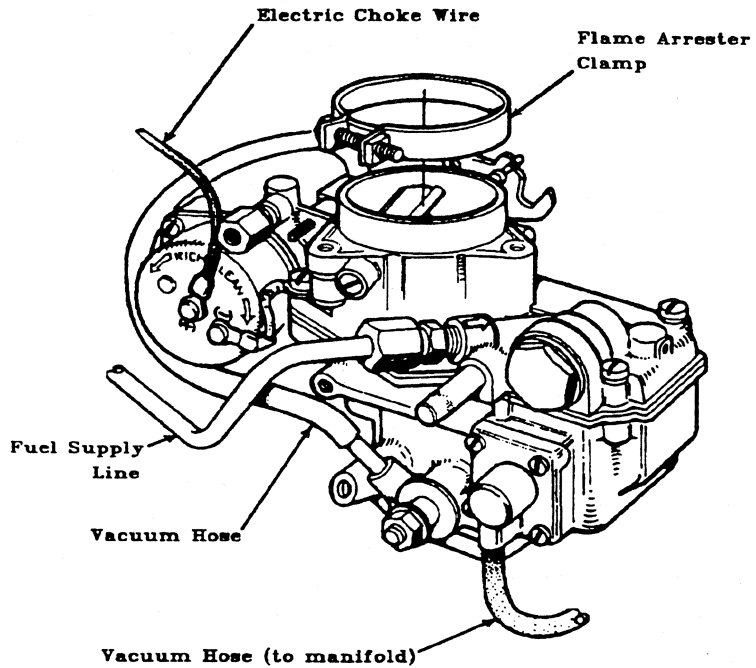

3. Disconnect the vacuum hose at one end. Remove the cotter pin from the electric choke to control lever rod and disconnect the electric choke to control lever rod from the electric choke assembly.

4. Remove the two choke assembly retaining screws and their washers. Disconnect the electric choke assembly from the carburetor.

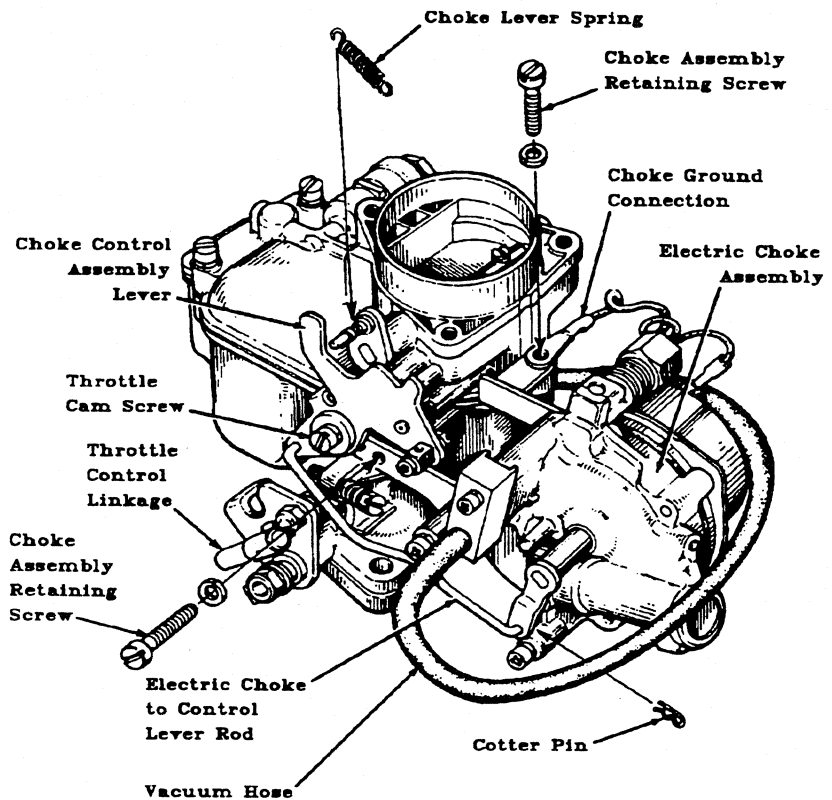

- Remove the four cover screws and their washers. Lift the carburetor's top cover straight up and away from the carburetor's base. Take off the four screws holding the accelerator housing cover to the side of the carburetor body. Remove the cover, accelerator diaphragm and spring. Inspect the diaphragm and replace it if cracked or porous.

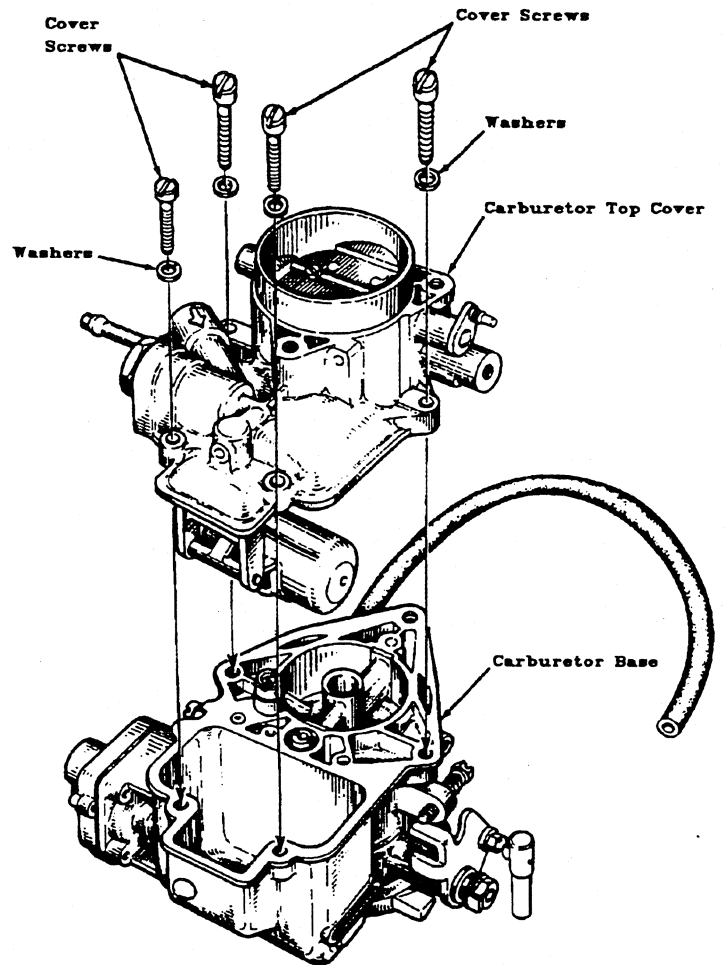
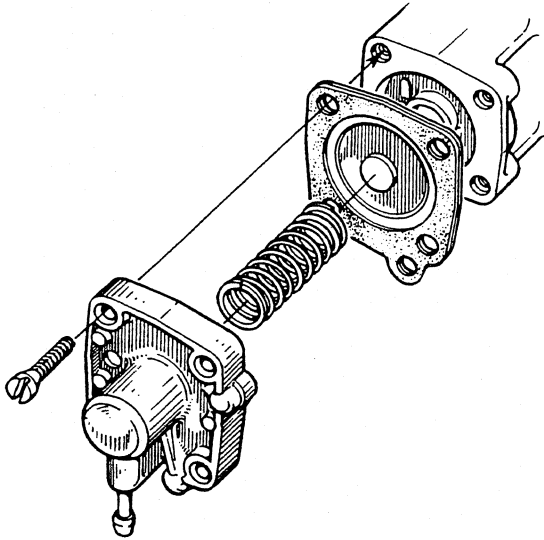

- In the carburetor top cover, gently punch out the float retaining pin in the opposite direction of the split side of the pivot bracket and remove the float. **Make sure you catch the needle valve that hangs from the float retaining hook under the float's pivot arm and place it aside.**

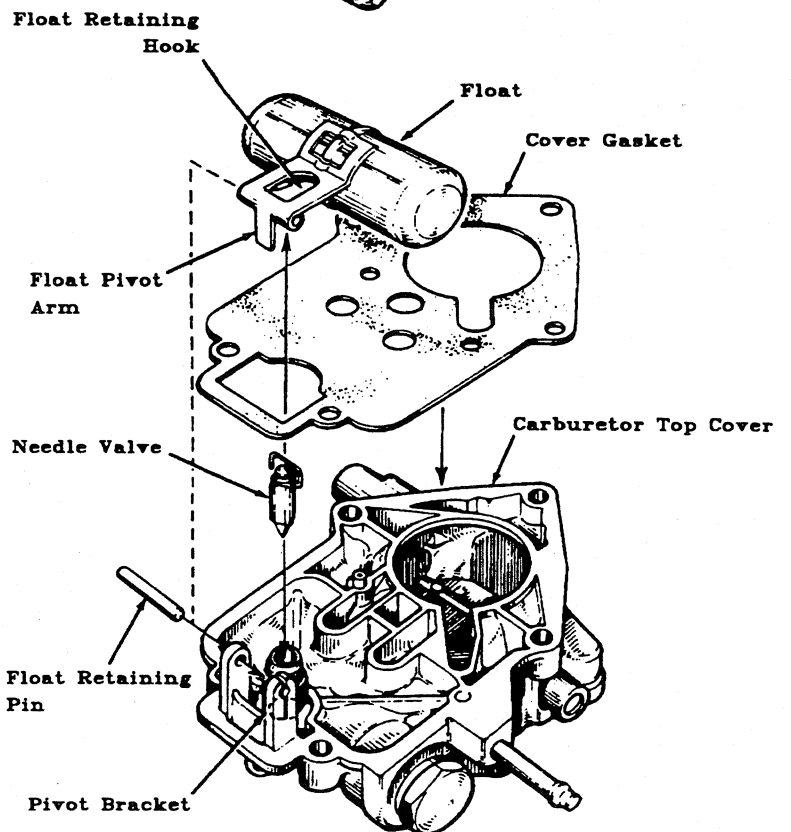

- Remove the old cover gasket.

- Shake the float. If you can hear any sand-like particles moving inside the float, replace it.

9. Remove the needle valve's seat with a 10 millimeter wrench. Make sure that the seat's aluminum gasket is removed at this time. Screw in the new seat along with a new gasket.

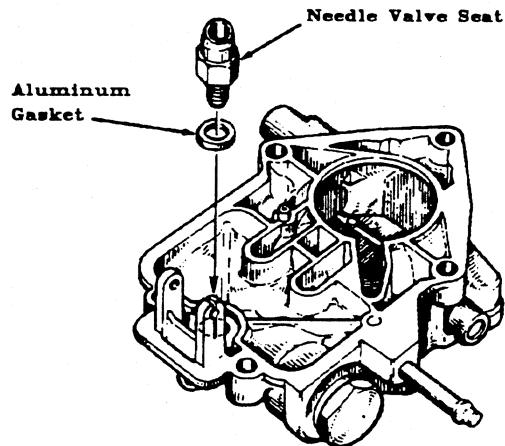

10. Place a new carburetor cover gasket on the carburetor top cover. Do not use any gasket sealer on this gasket.

11. Gently place the needle valve in the needle valve seat. Replace the float and float retaining pin so that the needle valve's wire retaining loop hooks onto the float's retaining hook. Now check the float level distance from the housing mating surface with the housing held vertically.

Distance "A" from mating surface: 3/16 inches (4.76 mm).

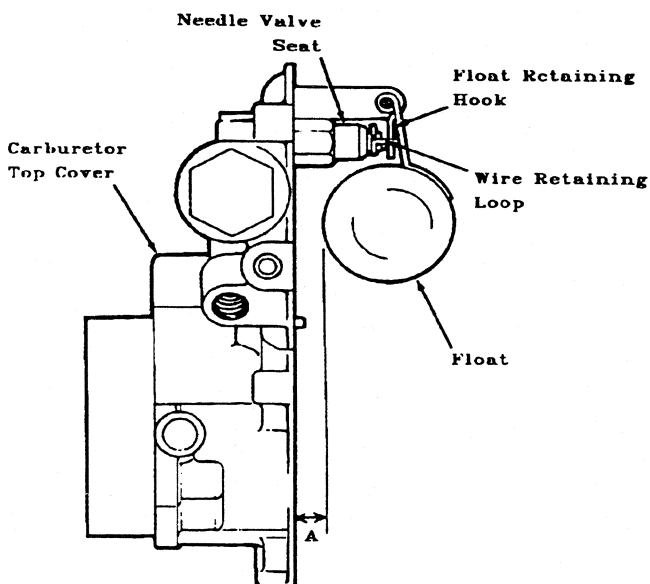
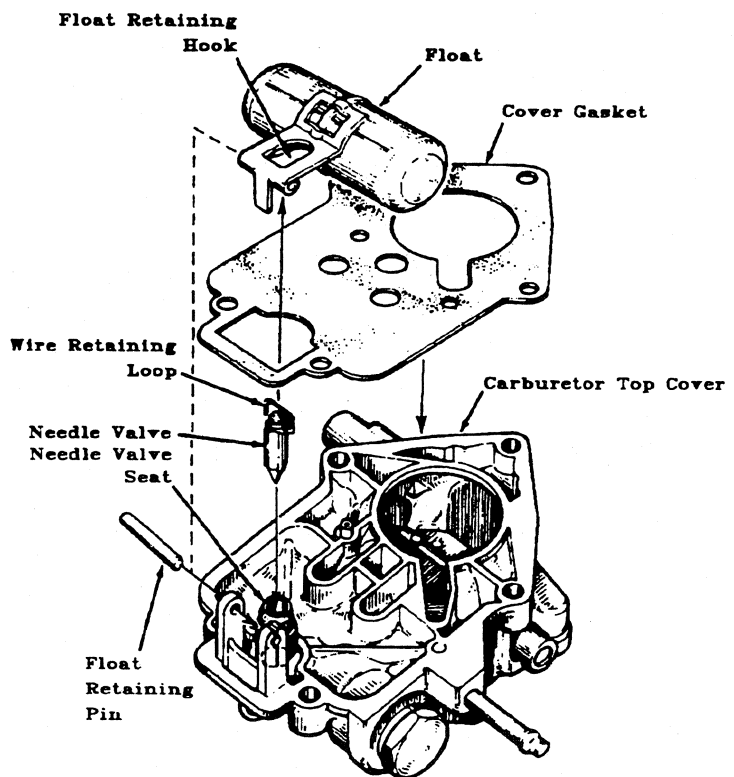

12. On the carburetor base, remove the retaining screw to the accelerator pump nozzle, the nozzle, and the two copper washers placed above and below the nozzle.

13. Replace the two copper washers and reinstall the accelerator pump nozzle. Snug down the nozzle's retaining screw. **Do not** over-tighten the screw. Reinstall the accelerator pump diaphragm, spring and housing. Snug down the four retaining screws.

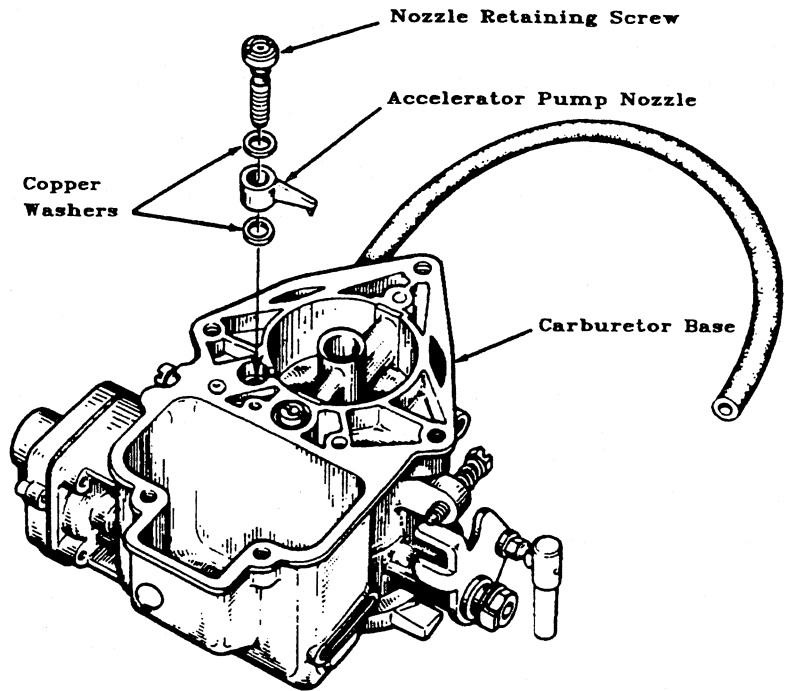

14. Place the carburetor top cover straight down on the carburetor base. Replace the four washers and hand tighten the four cover screws in the indicated order as shown in the drawing to the right. Snug down each screw. Over tightening these screws can strip the threads in the carburetor.

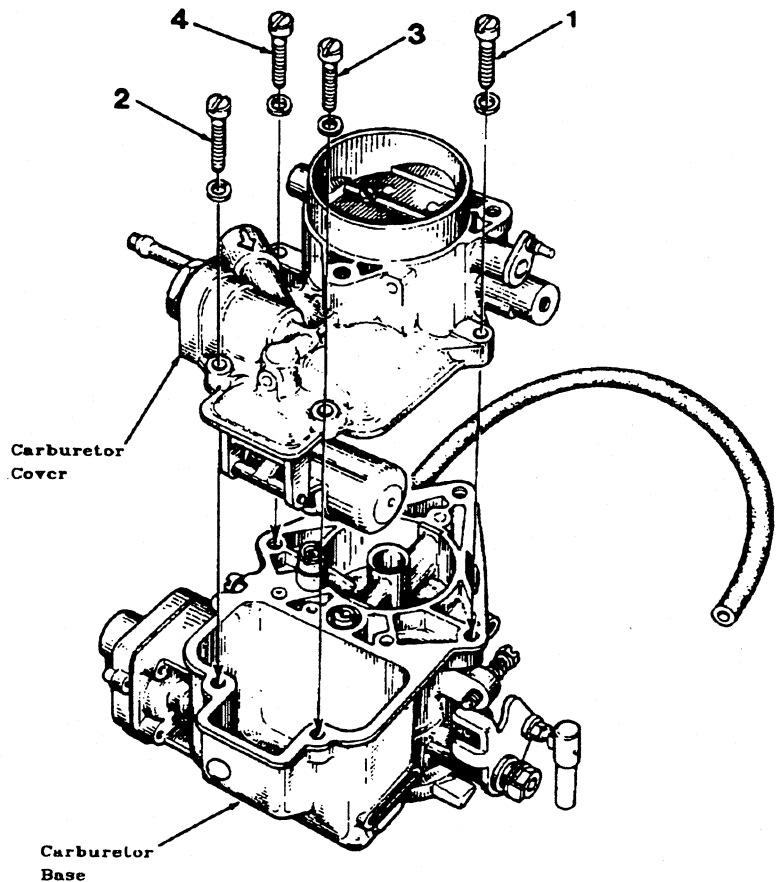

15. Reconnect the electric choke assembly to the carburetor and replace the two choke assembly retaining screws and their washers. Reattach the electric choke to control lever rod to the electric choke assembly and insert the cotter pin. Reattach the vacuum hose.

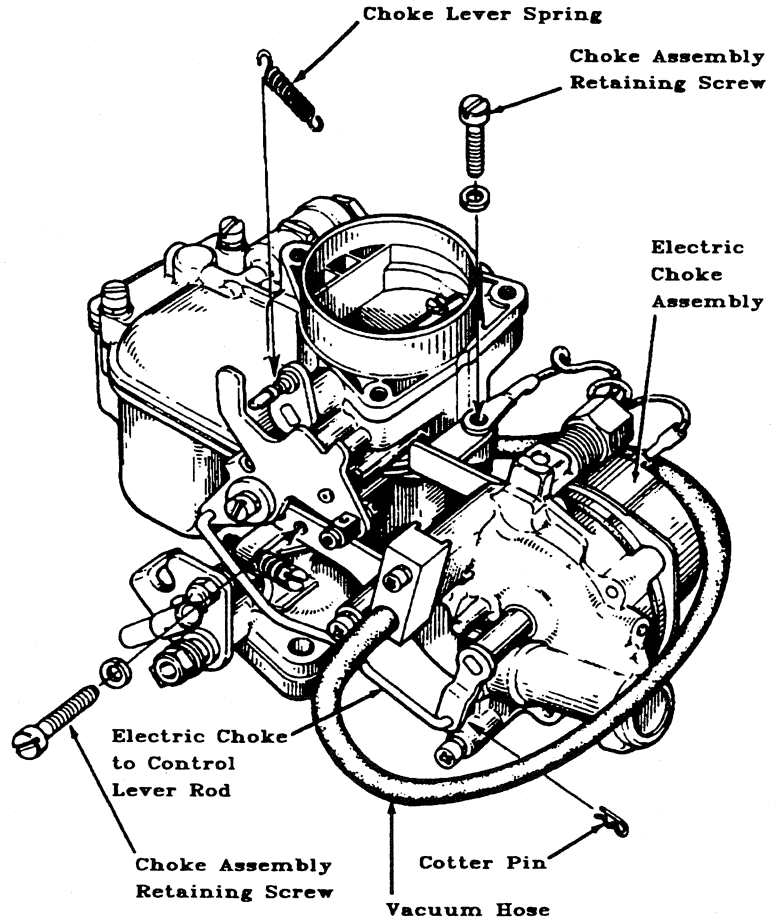

16. Replace the idle mixture screw's O-ring, the rotary throttle shaft valve and the rotary throttle shaft valve spring. Remove the fuel filter element plug and replace the fuel filter element.

Now the carburetor is rebuilt. Make sure all the screws on the carburetor are properly tightened and replace the carburetor on the intake manifold using a new manifold gasket along with a gasket sealant. Replace the two nuts and tighten the carburetor to the manifold.

Reconnect the throttle control linkage, the fuel supply line, the vacuum hose, and the electric choke wire. Replace the flame arrester on the carburetor and tighten the flame arrester clamp.

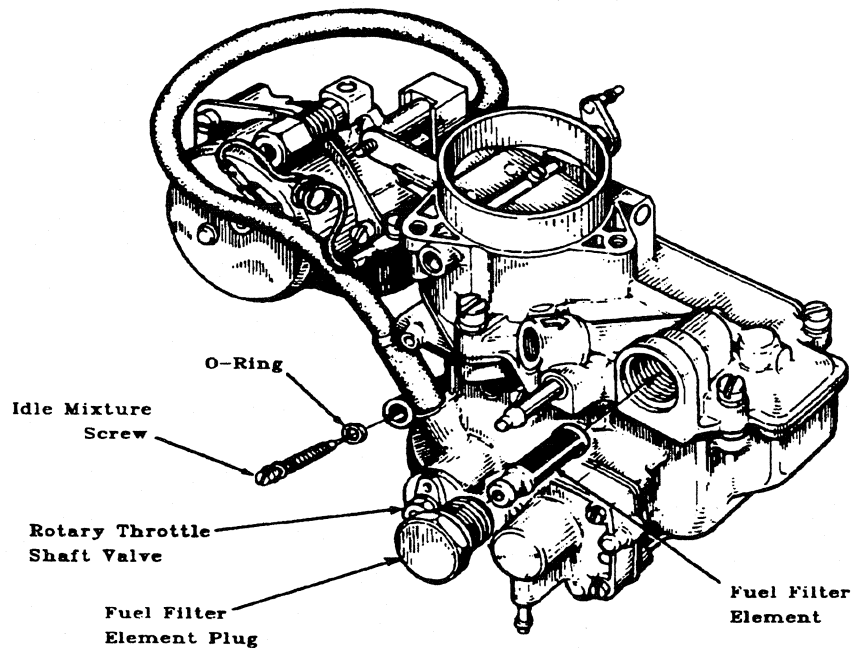

Electric Choke

The electric choke uses a 12 volt heating element which opens the choke automatically once the engine starts and is running.

NOTE: Some hunting will be present when the generator is first started, when the choke is on, and when the generator has no-load on it.

The choke is adjusted with the engine off and cooled. Adjust the choke by loosening the three cover-securing screws and rotating the cover clockwise to **LEAN** the choke and counterclockwise to **RICH** the choke. The choke is initially set at the factory for an average of 70° F (21° C) room temperature.

The choke may need readjustment at engine commissioning for the ambient temperature of the area the engine is operating in.

The choke index mark is located on the choke cover lower right inboard side.

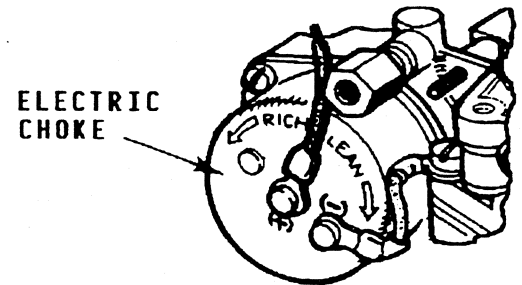

WARNING

The choke housing will normally get hot during engine operation.

NOTE: When initially starting the engine (commissioning) or after servicing the fuel system, prime the engine's fuel system by using the engine mounted fuel pump. Prime the fuel system by depressing the control panel's ON switch. To prevent the unwanted activation of the carburetor's electric choke, unplug the 12 volt (+) lead at the electric choke during this priming operation and reconnect it after priming to start the engine.

Electric Fuel Pump (Early Models)

The engine-mounted electric fuel pump supplies fuel to the engine's carburetor during engine operation. A cleanable filter screen is contained in the pump's base.

Remove the base by placing a wrench on the hex nut and twisting it loose from the bayonet fittings. Clean the screen as needed. A new base gasket #34706 *must* be installed each time the pump base is removed and reinstalled.

WARNING

Shut off the fuel service valve at the engine when servicing the fuel system. **Take care in catching any fuel that spills from within the pump when the base is removed. Do not allow any smoking, open flames, sparks or other sources of fire near the fuel system when servicing.** Ensure proper ventilation exists when servicing the fuel system.

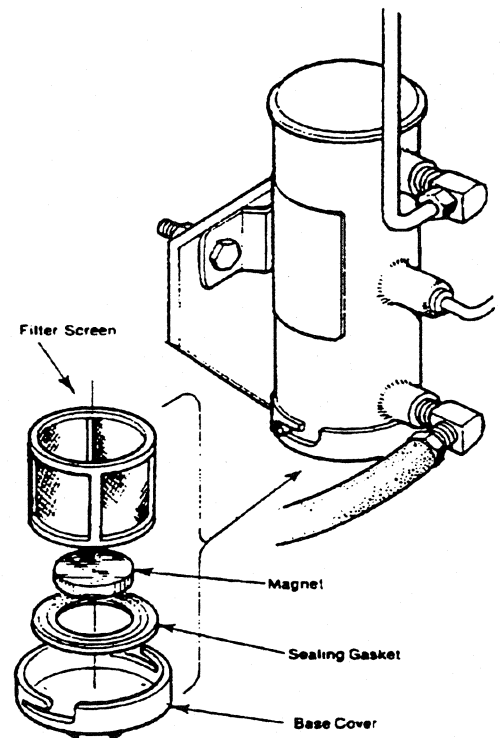

Electric Fuel Pump (Later Models)

Later models are equipped with a Solid State interrupter type fuel pump that operates well under high ambient temperature condition, however, it does not incorporate any fuel filter/screen in its construction.

Installers/operators *must* ensure that fuel being supplied to this pump is free of water or other types of contaminants that will hinder the pumps operation or affect the carburetor further down stream.

Periodically check the fuel connections to and out of the pump and make sure that no leakage is present and that the fittings are tight and secure. Also, check that the DC electrical connection supplying 12 volts DC to the pump is clean, tight, and secure. The DC ground connection at one of the pumps mounting bolts should be clean and well secured by the mounting bolt to ensure proper pump operation.

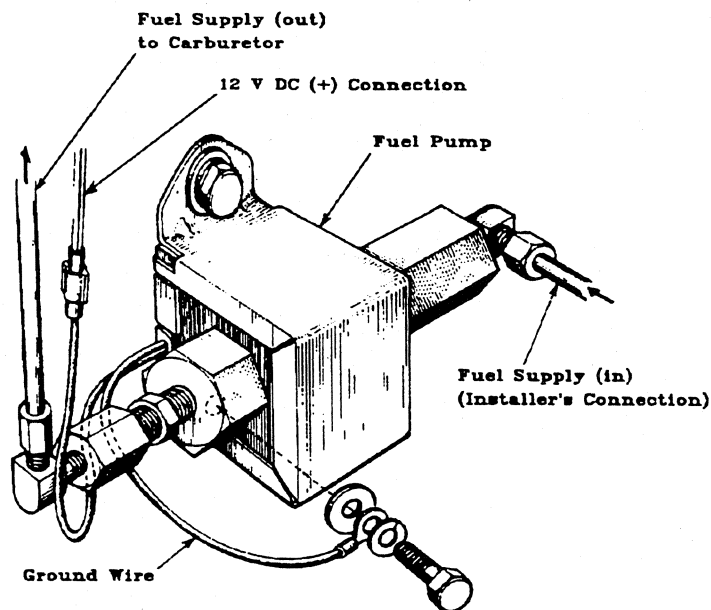

WARNING

Fuel leakage at the fuel pump or its connections is a fire hazard and should be corrected. Make sure proper ventilation exists whenever servicing fuel system components.

Troubleshooting the Fuel System

<u>Fault</u>	<u>Possible Cause</u>	<u>Correction</u>
Hard starting.	1. Faulty choke.	1. Check choke adjustment and operation. Check choke cam for smooth radius.
	2. Fuel.	2. Check fuel supply and correct type.
	3. Fuel pump.	3. Check pump operation and clean filter screen.
	4. Faulty idle jet adjustment.	4. Adjust idle jet.
Flooded.	1. Carburetor float needle valve open or damaged.	1. Clean or replace the needle valve.
	2. Float in carburetor leaking.	2. Repair or replace float.
	3. Float chamber gasket damaged or securing screws are loose.	3. Replace gasket and/or tighten screws.
	4. Choke stuck.	4. Repair.
Poor performance at generator speed.	1. Main jet clogged.	1. Remove and clean.
	2. Carburetor inlet filter clogged.	2. Remove and clean.
	3. Fuel pump filter clogged.	3. Remove and clean.
	4. Air intake filter screen dirty.	4. Remove and clean.

Disassembling the Oil Pump

Disassemble in the following order.

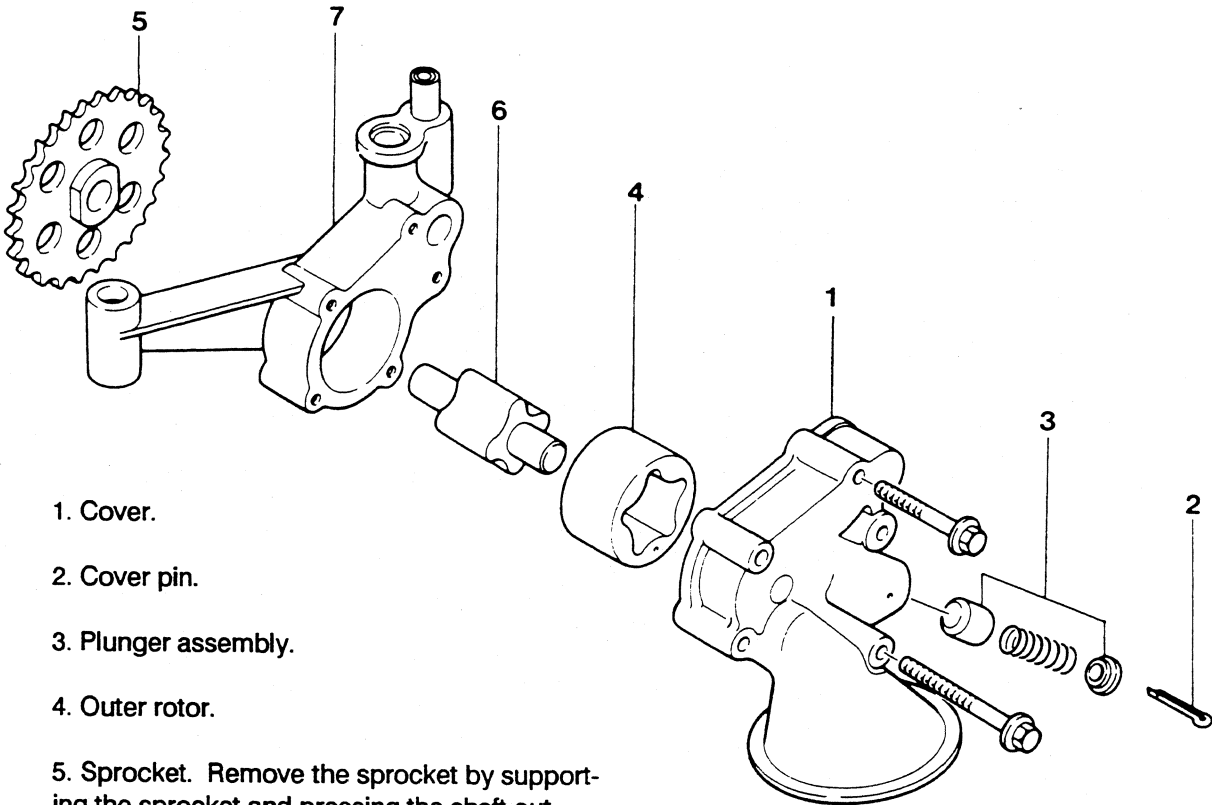

1. Cover.
2. Cover pin.
3. Plunger assembly.
4. Outer rotor.
5. Sprocket. Remove the sprocket by supporting the sprocket and pressing the shaft out.
6. Shaft and inner rotor assembly.
7. Pump body.

Checking the Oil Pump

1. Examine the following parts and replace them if the following is found.

- a. A deformed or damaged pump body and cover.
- b. A worn or damaged plunger.

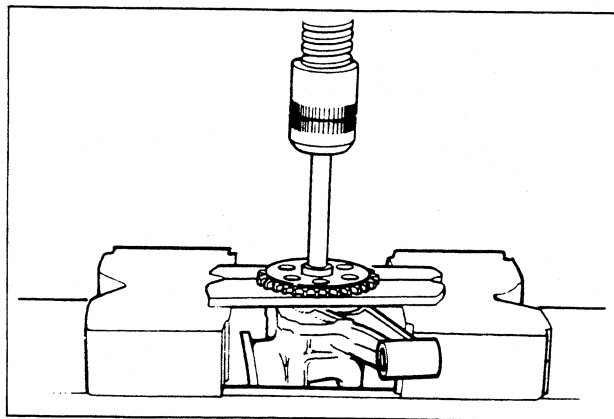

2. Check the clearance between the lobes of the rotors with a feeler gauge. If the clearance exceeds the limit, replace both rotors.

Clearance limit: 0.25 mm (0.010 in).

3. Check the clearance between the outer rotor and the pump body with a feeler gauge. If the clearance exceeds the limit, replace the rotor or pump body.

Clearance limit: 0.35 mm (0.014 in).

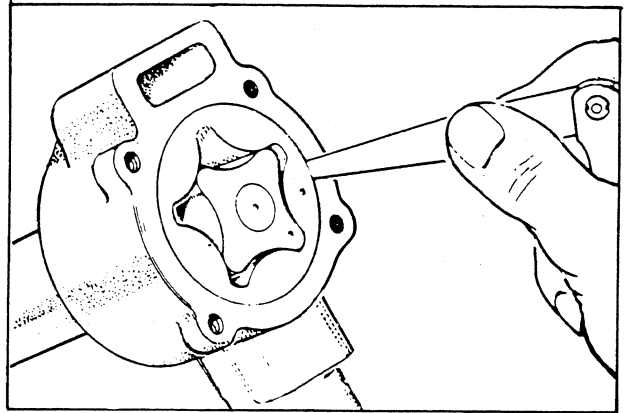

4. Check the end float of the rotors. Place a straight edge across the pump body and measure the clearance between the rotor and the straight edge with a feeler gauge. If the clearance exceeds the limit, replace the drive gear, drive shaft, inner rotor, outer rotor and pump body.

Clearance limit: 0.15 mm (0.0059 in).

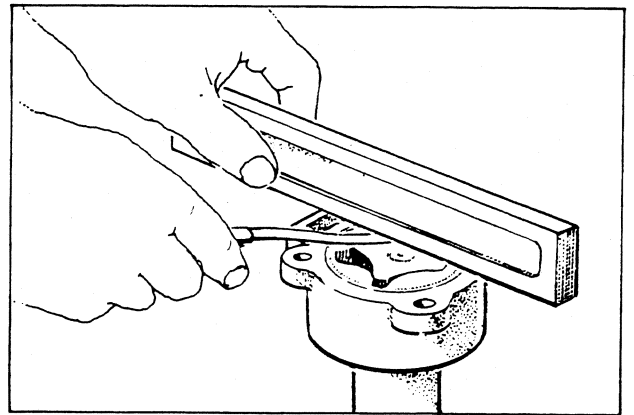

5. Then, place a straight edge across the pump cover and measure the clearance between the straight edge and cover. If the cover exceeds the limit, correct the pump cover by grinding or replace it.

Clearance limit: 0.15 mm (0.0059 in).

6. Check the relief valve for a worn plunger and fatigued spring.

Spring free length: 45.5 mm (1.791 in).

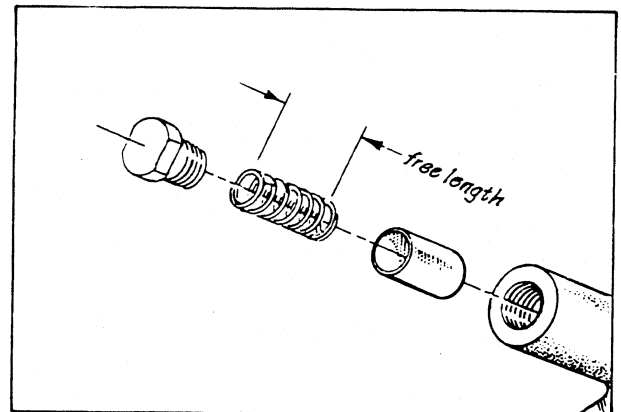

7. Clean the pick up strainer.

Assembling the Oil Pump

Assemble in the reverse order of disassembling.

NOTE: Press the drive gear onto the pump shaft until the surface becomes flush with the end surface of the shaft. If the pressing pressure is less than the specified value, replace either the sprocket or shaft, or both.

Pressing pressure: 700 - 1300 kg (1540 - 2860 lbs).

NOTE: Make sure, when assembled, the tally marks on both outer rotor and inner rotor face toward the outside (cover side).

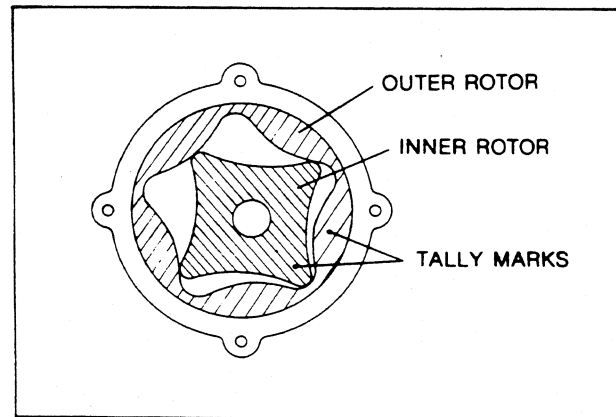
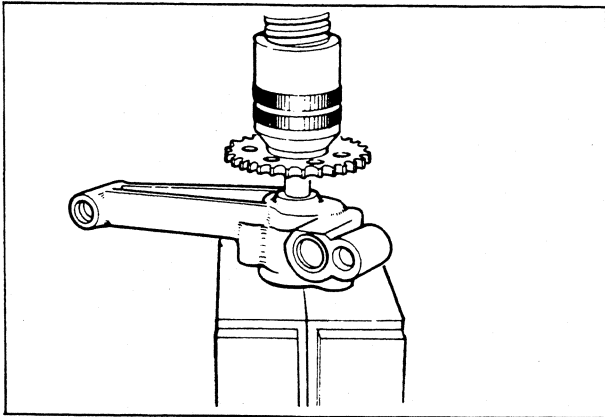

Reinstall the pump in the engine.

Fresh Water Pump

With the fresh water pump removed from the engine, inspect the pump for cracks or visibly damaged parts. Rotate the impeller shaft and feel/listen for abnormal bearing rotation and observe if there is an indication of shaft seal leakage.

Disassembly

Disassemble in the order shown in the figure.

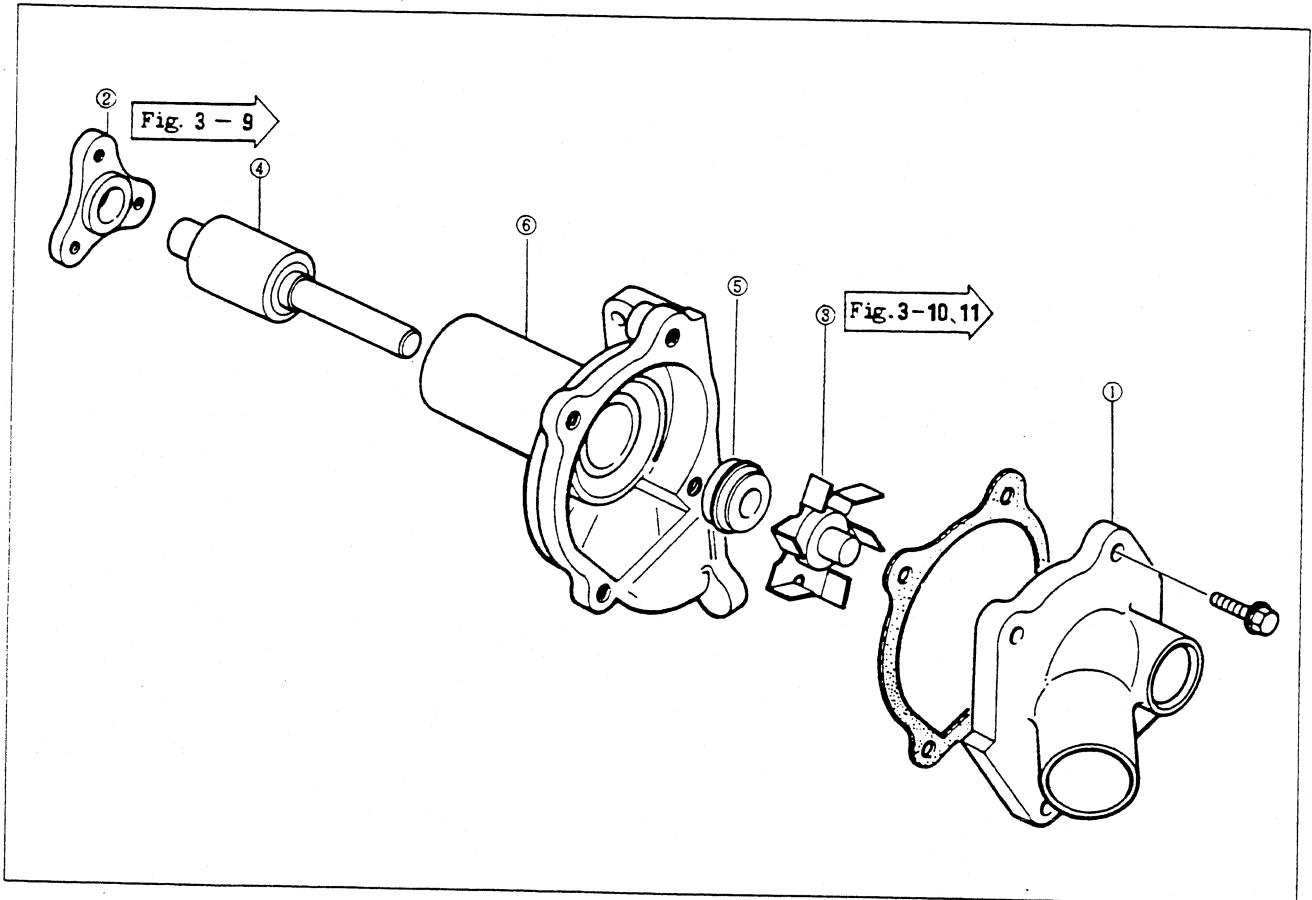

1. Cover
2. Pulley boss

3. Impeller
4. Shaft and bearing assembly

5. Water seal
6. Pump body

Remove the pulley boss by supporting the pulley flange and push the impeller shaft out of the flange.

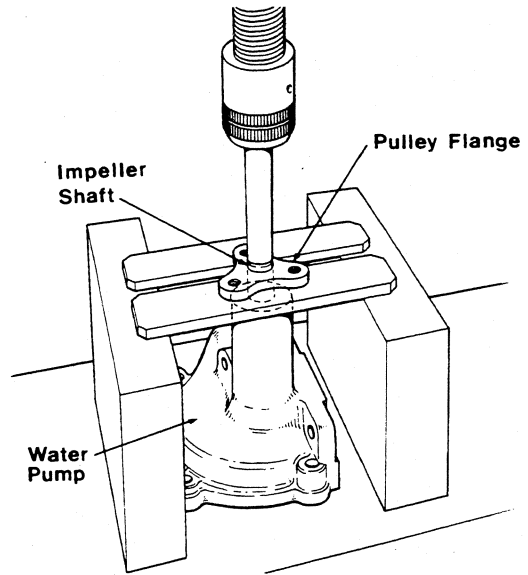

To remove the impeller from the shaft, the head of the impeller *must* be ground or cut carefully with a chisel to expose the shaft.

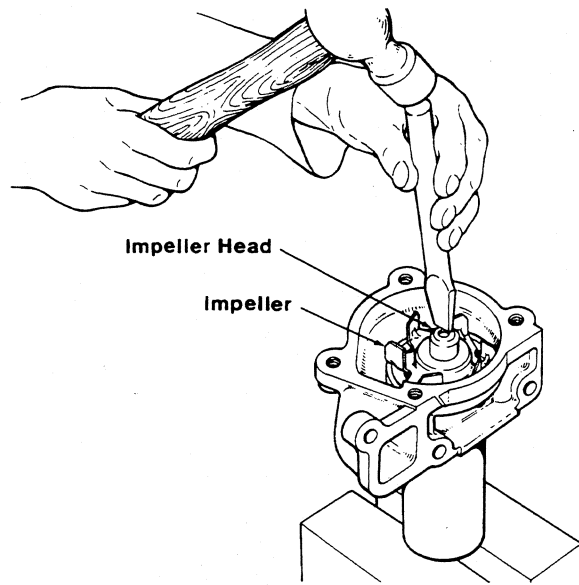

Support the housing of the pump and push the shaft out of the impeller and housing with its bearing assembly. **Do not** reuse the impeller. The shaft and bearing should be replaced as an assembly.

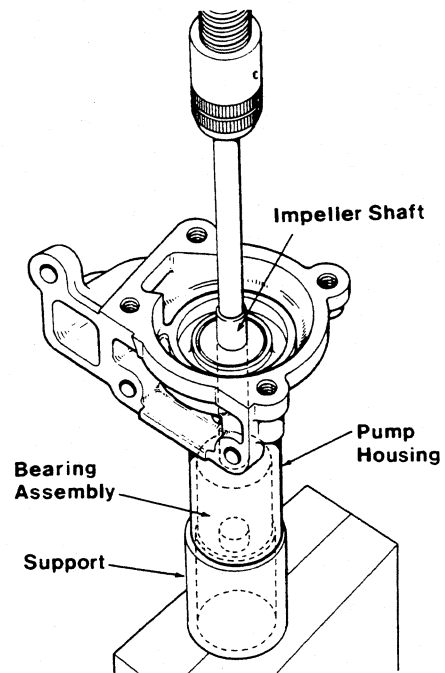

Assembly

Assemble the water pump in the reverse order of the disassembly.

Take care of the following:

Apply a slight amount of engine oil to the oil seal section of the water seal.

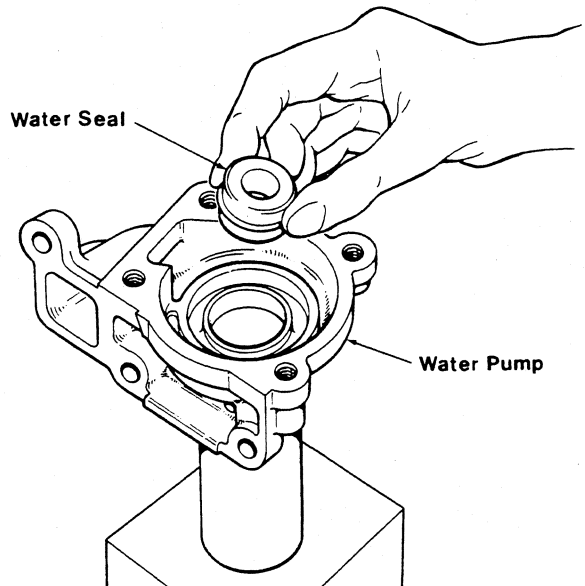

Support the pulley flange and press the shaft and bearing assembly into the flange. Support the pump body and press the shaft and bearing assembly into the pump.

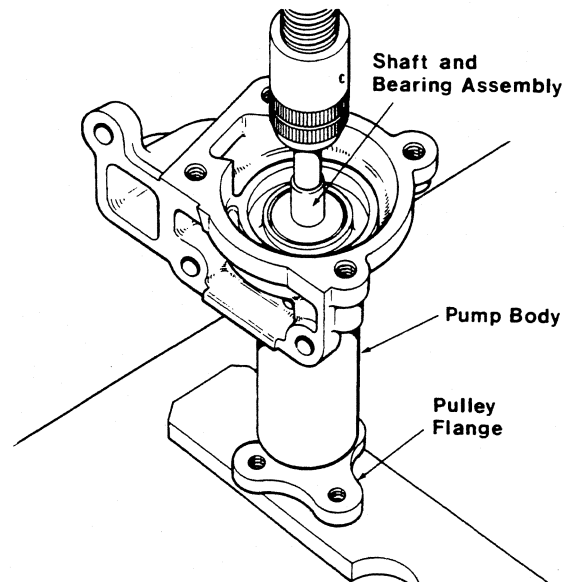

Press-fit the impeller while paying careful attention to the air-escape hole on the impeller.

Impeller press-fit pressure: 1200 - 1300 kg
(2650 - 2870 lb).

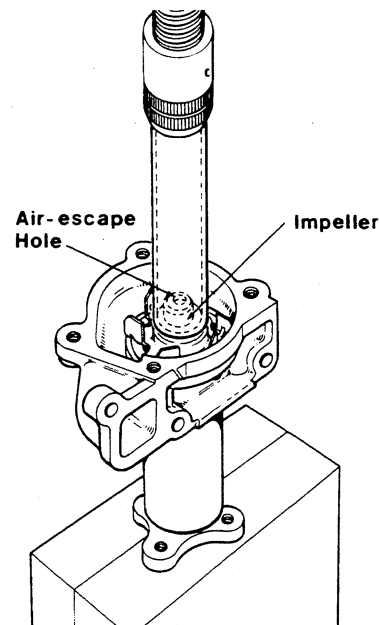

Installation

Install the pump back on the engine.

Take care of the following:

Make sure that there are no leaks from the water pump. Adjust the tension of the V-belt.

The Distributor

The distributor is a solid state type without breaker points and, therefore, requires no adjustment. It consists of a cap, rotor, signal generator, igniter and centrifugal advance system.

The signal generator consists of a signal rotor, magnet and pickup coil. When the signal rotor is driven, the amount of magnetic flux through the pickup coil varies and an electric signal is conducted at both ends of the pickup coil and sent to the igniter.

The centrifugal advance controls the signal generator timing so as to control the ignition timing according to the engine speed and load.

Checking the Distributor

1. The cap and rotor should be examined when servicing the spark plugs and checked for cracks, and to ensure the terminals are clean and free of corrosion. If it's defective, replace it.
2. Start the engine and warm it up to normal operating temperature.
3. Using the timing light, align the timing groove in the front crankshaft pulley with the proper timing mark on the ignition timing scale embossed on the engine front cover. Do this by loosening and slowly rotating the distributor body.

Timing:

8.5 KW BTG	14° BTDC at 1800 rpm
12.5 KW BTG	18° BTDC at 1800 rpm
15.0 KW BTG	18° BTDC at 1800 rpm

NOTE: Timing marks are in 2 degree increments.

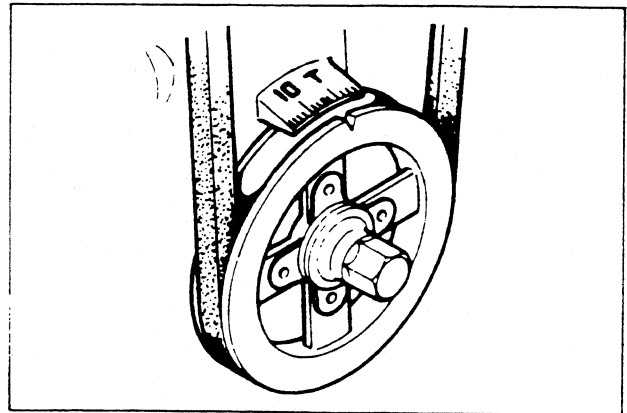

Distributor Disassembly

Remove the following:

1. Wires from the distributor noting their position for replacement.
2. The distributor from the engine.
3. The cap.
4. The rotor
5. The pickup coil and igniter.

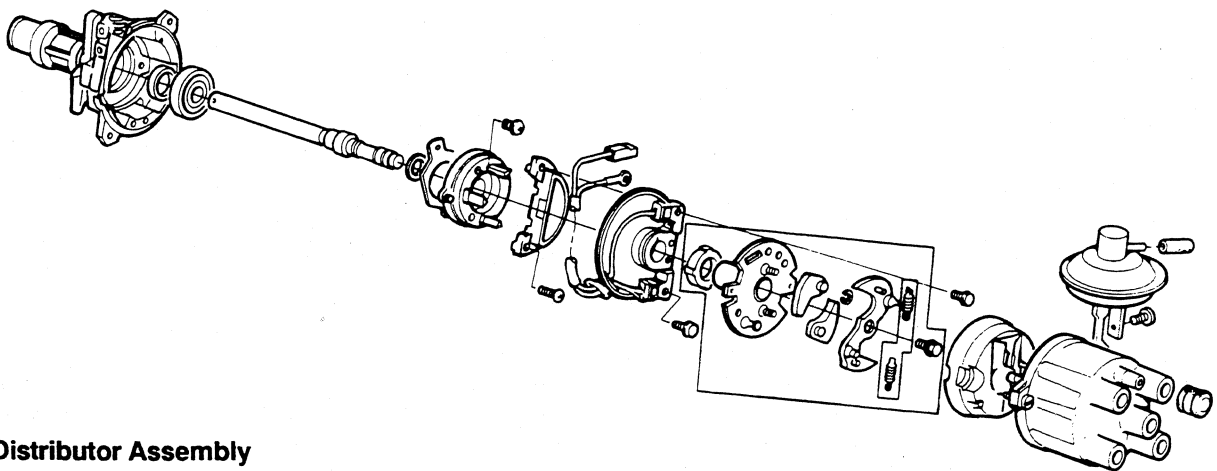

Distributor Assembly

1. Assemble in the reverse order of disassembly.
2. Apply engine oil sparingly to the o-ring on the distributor shaft.
3. Insert the distributor shaft by turning it. Ensure the distributor shaft fits into the groove on the rear of the camshaft which is offset to provide proper timing.
4. Adjust engine timing according to the specifications.

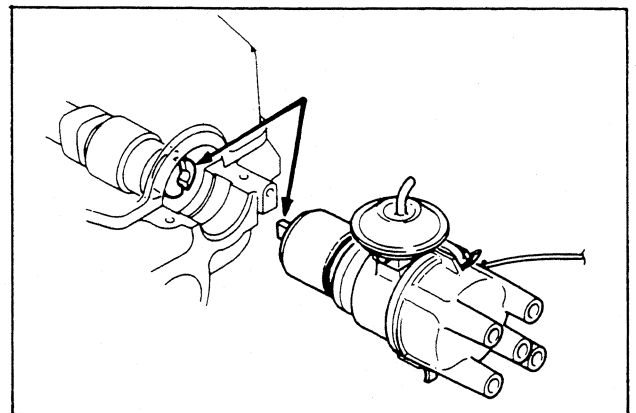
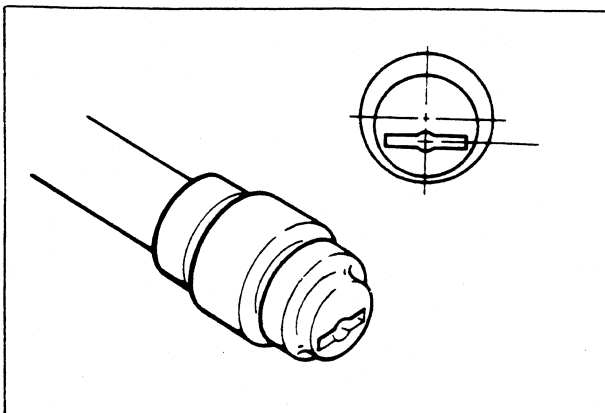

Spark Plugs

Service the spark plugs. Clean, gap or replace as needed.

Spark plug gap: 0.8 ± 0.05 mm (0.031 ± 0.002 in).

Spark plug torque: 1.5 - 2.3 kg-m (10.8 - 16.6 lb - ft).

Check plugs for damage and/or wear.

NOTE: Loc-tite "anti-seize" applied to the threads will retard corrosion making future removal easier.

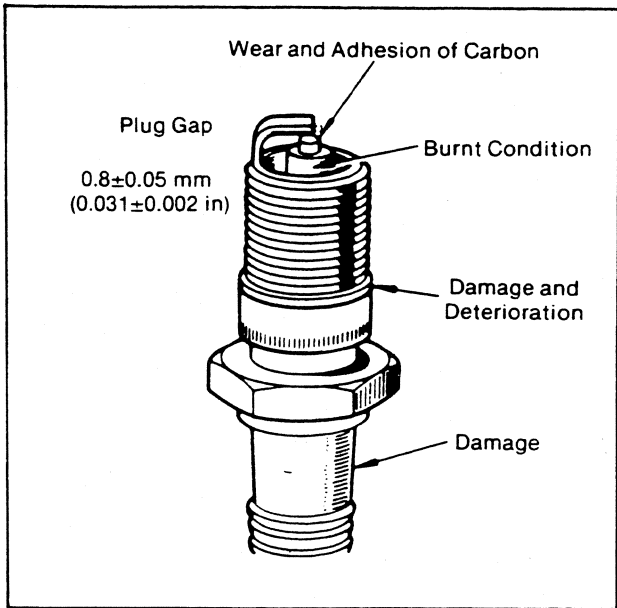

High Tension Leads

Check leads for clean and secure terminal ends. Resistance value of high tension lead wire is 410 ohm per inch of wire.

NOTE: When removing leads from spark plugs, be sure to pull at the plug cap, not at the high tension lead.

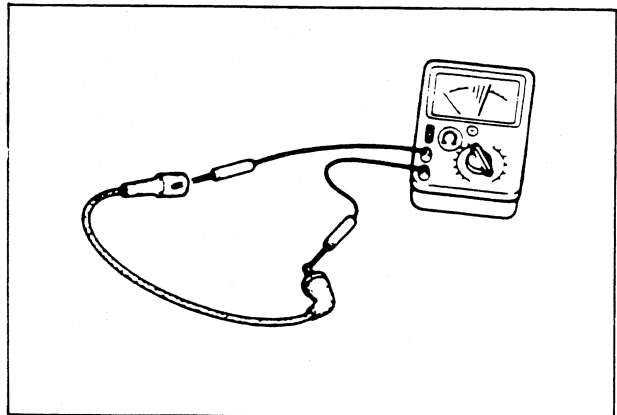

Ignition Coil (Resistance Check)

1. The resistance value of primary coils is 0.8 ± 0.2 ohm (ohmmeter RX1 scale).

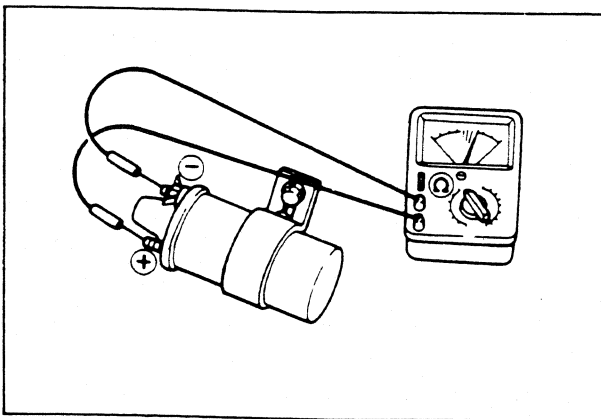

Checking the primary coil.

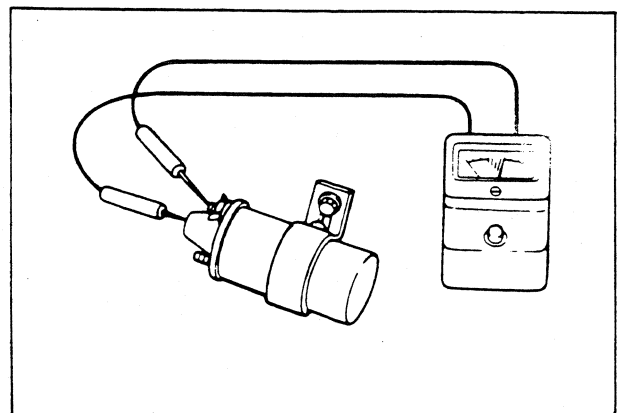

Checking the secondary coil.

2. The resistance value of the secondary coil is 100 Ohm (+ or - 10 ohm).

3. Check the insulation resistance between the primary terminal and the coil case. (Megohmmeter 500 volt.)

Normal resistance: 10 Megohm +

The coil should be replaced should it not meet the resistance values given above.

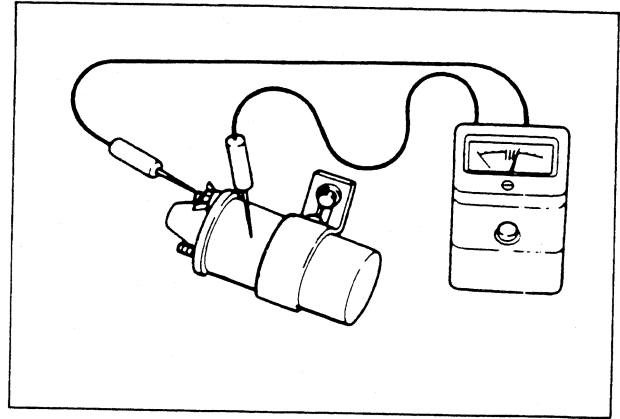

Checking the Overspeed Module

1. With the generator running, manually move the throttle lever to full open. The generator set should stop.
2. Depress ON and START switches. The generator should **not** start.
3. Depress the STOP switch to reset overspeed module circuit. Then depress ON and START; the generator should start properly.
4. To bypass the overspeed module to check the safety circuit, disconnect the black with the white stripe wire from the distributor at the connector in the harness. Use a jumper wire to connect this to the B+ of the coil. Remove all four wires from the overspeed module. Ensure they do **not** touch each other or ground.

WARNING

The overspeed module *must* be properly reconnected and functioning *before* operating the generator set.

Voltmeter

The voltmeter in the remote instrument panel can be a useful instrument in determining the status of your electrical system and warn you when an abnormality occurs. The voltmeter will indicate differently depending upon when the readings are taken.

Fully charged batteries that are in a static state should read between 12.3 and 12.6 volts on the dial. The term static means that the battery has not been charged or discharged for at least 2 hours. If the reading is between 11 and 11.5 volts, then the battery is about half discharged and should be charged to ensure its usefulness. If the engine is started and the needle does not go up, this would indicate that no charge is being delivered to the battery.

When the battery is being charged, the needle should be between 12.6 and 13 volts. The needle may move up to about the 14.6 volt range toward the end of the charge cycle, at which time the needle drops back to the 12.6 to 13 volt range, as voltage regulation controls this function. If the battery voltage exceeds 15 volts, this indicates the battery is being overcharged which will damage the battery if left unchecked. The voltage regulator is most likely at fault.

When the battery is being charged (having electrical loads placed upon it and no charging current applied), it is normal for the needle to indicate between 11.4 and 12.6 volts.

NOTES

DC ELECTRICAL SYSTEM

Safety Information

This circuit is designed and manufactured in compliance with United States Coast Guard Standards (33 CFR PART 183). No modifications may be made to it by the installer or user. It is the installer's responsibility to assure that the installation of the generator set and any remote start panels or remote instrument panels are installed in compliance with the above Coast Guard Standards. Failure to observe these requirements could be the cause of injury.

DC Circuit Description

The two-pole ON switch is operated to bypass the protective shutdown switches during starting. The second pole provides a source of B+ to the START toggle switch. While continuing to hold the ON switch, to provide B+ to the start switch and to bypass the protective shutdown switches, the START switch is pressed to energize the starter to crank the engine. If you are starting the generator at the generator set, release the START switch when the generator is running. If starting the generator at a remote location, release the START switch when the green LED lights, but continue depressing the ON switch. After releasing the START switch, continue holding the ON switch until oil pressure is sufficient to close the oil pressure safety switch, providing the normal B+ path to the ignition system. Note that it is now impossible to energize the starter while the generator is running until someone again operates the ON switch first. Should the generator shut down from an overspeed condition, the overspeed circuit *must* be reset before attempting to restart the generator. Resetting the overspeed circuit is done by simply depressing the STOP switch momentarily and then proceeding with the normal starting procedure.

WARNING

It is very important that the overspeed shutdown always be installed and functioning. Any tampering with the overspeed shutdown module, which would cause it to malfunction, could be a cause of injury should the generator's belt-driven governor fail and cause the generator to run away.

To STOP the generator, depress the STOP switch which opens the normally closed B+ path on the ON and START switches. The STOP switch *must* be held open until the generator comes to a complete stop. Remote start panels may be connected to the generator set as indicated. A jumper has to be removed between the T1 and T2 connections at the panel connection terminal board. (Refer to the wiring diagram in the "ELECTRICAL SYSTEM" section of this manual.)

WARNING

When installing the optional remote start panel or the optional remote instrument panel, it is the installer's responsibility to comply with U.S. Coast Guard Standards 33 CFR PART 183 regarding location and wiring.

DC WIRING DIAGRAM #37190

Page 1 of 2

WIRING DIAGRAM

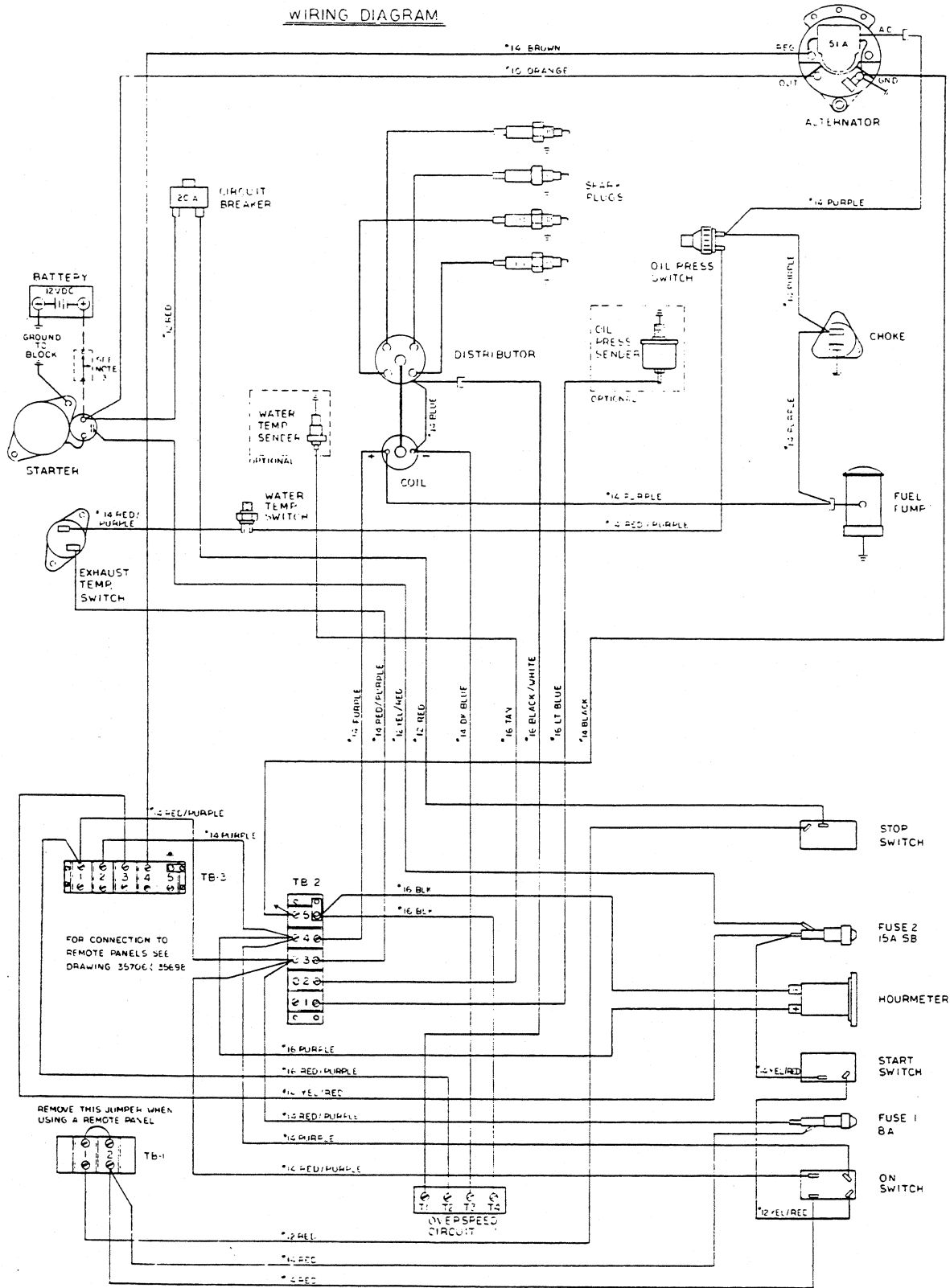

DC WIRING DIAGRAM # 37190

Page 2 of 2

SCHEMATIC DIAGRAM

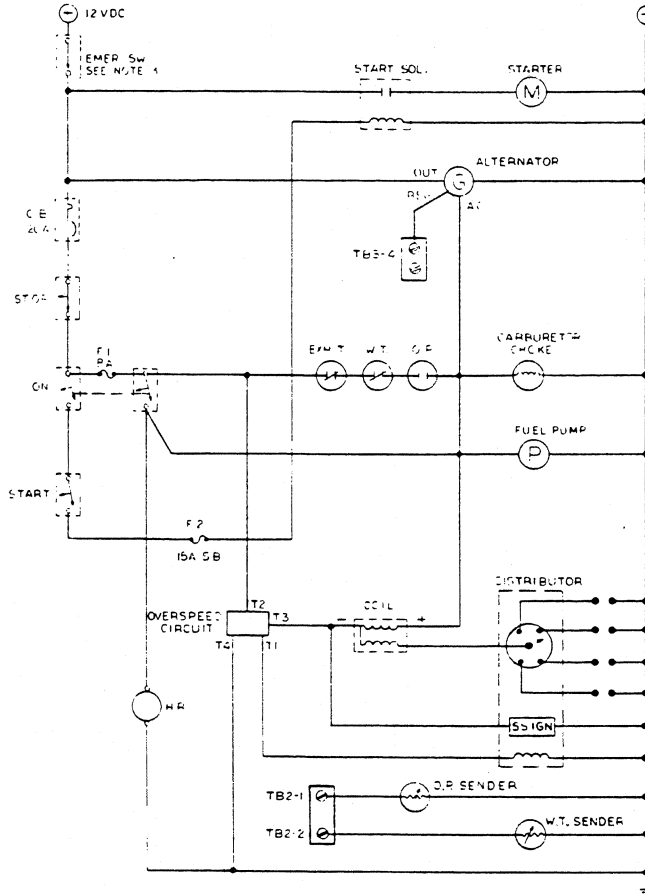

NOTES:

1. WESTERBEKE GASOLINE MARINE GENERATORS AS SHIPPED FROM THE FACTORY AND EXCLUSIVE OF OPTIONAL REMOTE INSTRUMENT OR CONTROL PANELS COMPLY WITH U.S. COAST GUARD 33CFR-183. ACCESSORY INSTRUMENT AND CONTROL PANELS DO NOT NECESSARILY SO COMPLY AND ARE INTENDED TO BE INSTALLED ABOVE DECK AND ISOLATED FROM GASOLINE SOURCES IN ACCORDANCE WITH 33CFR-183.410(B).

IT IS THE RESPONSIBILITY OF THE BOAT MANUFACTURER TO INSURE THAT THE INSTALLATION OF THESE GENERATORS AND OPTIONALLY THEIR REMOTE INSTRUMENT PANELS, COMPLY WITH 33CFR183.
2. THIS PRODUCT IS PROTECTED BY A MANUAL RESET CIRCUIT BREAKER LOCATED NEAR THE STARTER AND AS CLOSE AS POSSIBLE TO THE SOURCE OF CURRENT. EXCESSIVE CURRENT DRAIN ANYWHERE IN THE INSTRUMENT PANEL, WIRING OR ENGINE WILL CAUSE THE BREAKER TO TRIP. IN THIS EVENT THE ENGINE WILL SHUT DOWN BECAUSE THE OPENED BREAKER WILL DISCONNECT THE FUEL SUPPLY. THEREFORE, THE BUILDER/OWNER MUST BE SURE THAT THE INSTRUMENT PANEL, WIRING AND ENGINE ARE INSTALLED TO PREVENT CONTACT BETWEEN ELECTRICAL DEVICES AND SALT WATER.
3. AN ON-OFF SWITCH MUST BE INSTALLED TO DISCONNECT THE STARTER FROM THE BATTERY IN AN EMERGENCY AND WHEN LEAVING THE BOAT TWELVE VOLT STARTERS TYPICALLY DRAW 200 TO 300 AMPS WHEN CRANKING. THE DURATION OF INDIVIDUAL CRANKING CYCLES SHOULD NOT EXCEED 30 SECONDS. A SWITCH WITH A CONTINUOUS RATING OF 175 AMPS AT 12 VOLTS WILL NORMALLY SERVE THIS FUNCTION, BUT A SWITCH MUST NOT BE USED TO MAKE THE CIRCUIT.
4. SENDERS ARE SUPPLIED WITH OPTIONAL INSTRUMENT PANEL.

OPTIONAL REMOTE START PANEL WIRING DIAGRAM # 35706

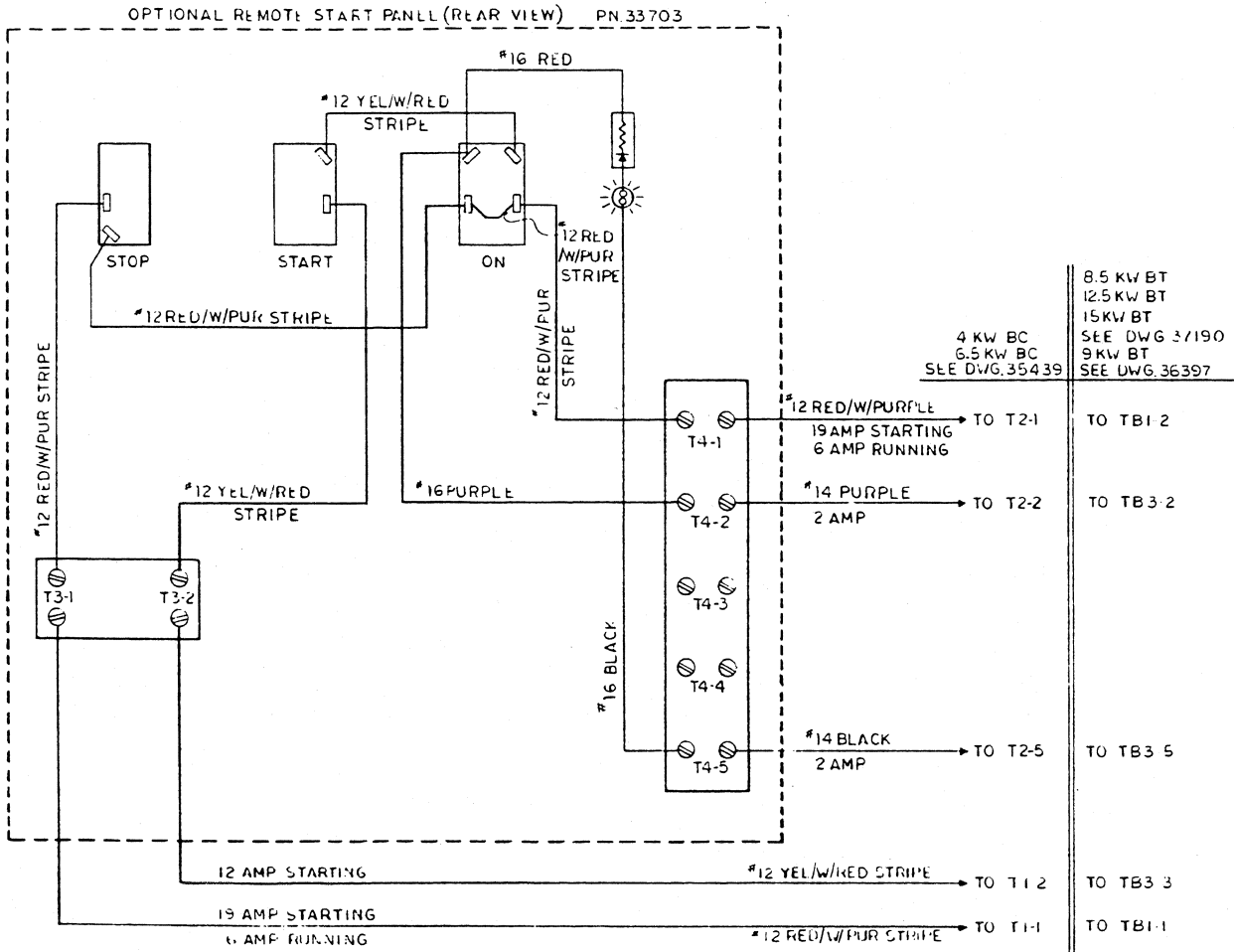

OPTIONAL REMOTE INSTRUMENT PANEL WIRING DIAGRAM # 35698

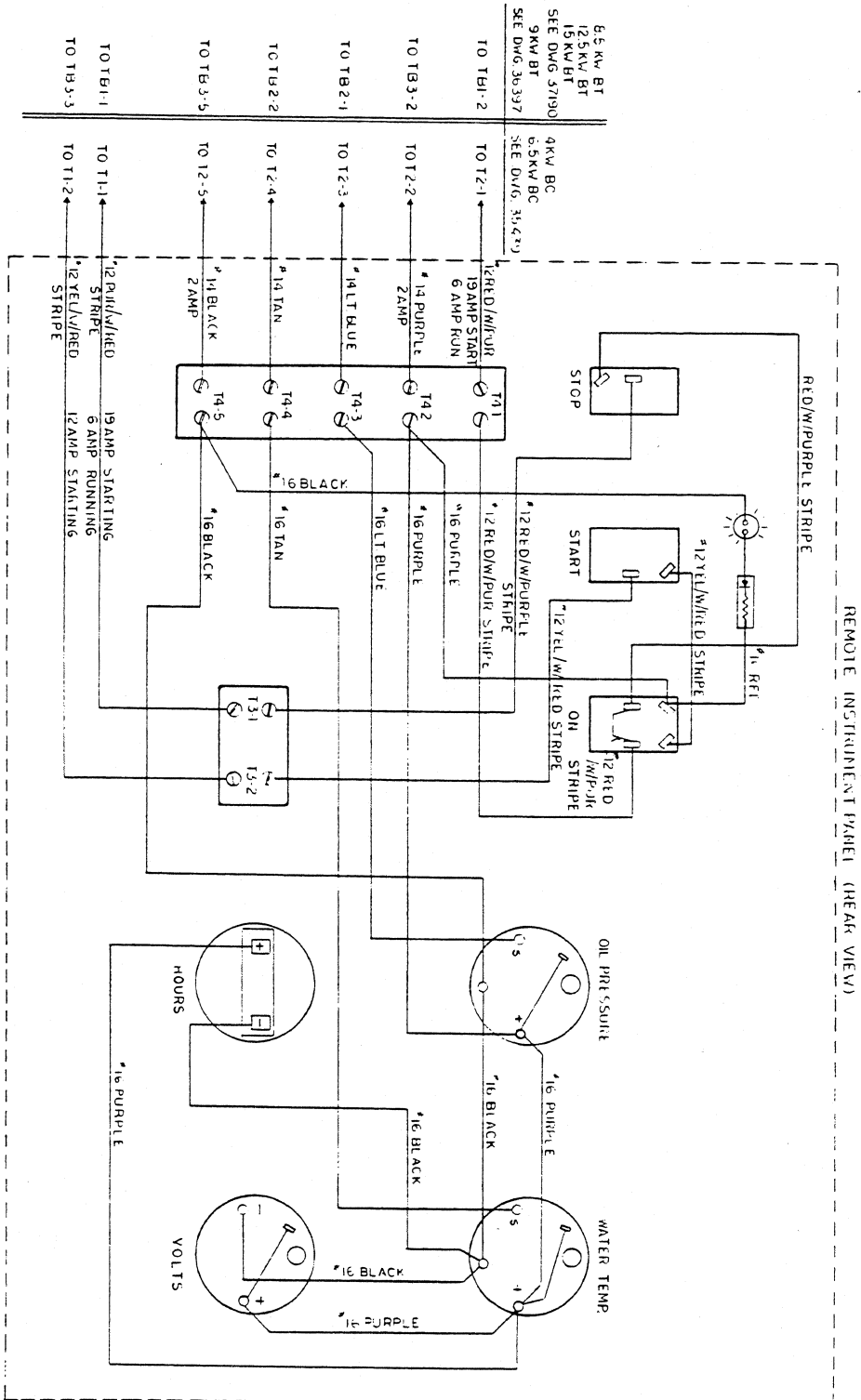

Electrical System Troubleshooting

<u>Fault</u>	<u>Possible Cause</u>	<u>Correction</u>
ON switch depressed, electric fuel pump not energized.	1. Battery switch or power not on.	1. Check switch and/or battery connections.
	2. 20 amp circuit breaker tripped.	2. Reset breaker if it opens again, check preheat solenoid circuit and RUN circuit for shorts to ground.
No ignition, cranks, does not start.	1. Overspeed module tripped.	1. Reset circuit by depressing stop switch.
	2. Fuse blown.	2. Check fuses; replace if necessary.
	3. Lack of fuel.	3. Check for fuel to generator set. Check fuel lift pump.
	4. Choke faulty.	4. Check to see that it is not jammed. Should be closed if engine is cold.
	5. Coil faulty .	5. Check coil.
	6. Distributor faulty.	6. Check distributor, cap and wires.
	7. Wiring faulty.	7. Check wires and connections for shorts, breaks and corrosion.
Starts, stops when ON switch released. .	1. Safety circuit switch or wiring faulty.	1. Inspect all wiring for shorts, corrosion or loose connections. Check operation of switches.
	2. Fuse blown.	2. Check fuses.
	3. Overspeed module faulty.	3. Check module.

<u>Fault</u>	<u>Possible Cause</u>	<u>Correction</u>
Engine stops.	<ol style="list-style-type: none"> 1. Low oil pressure or overheated. 2. Low oil pressure switch fails to close. 3. High water or exhaust temperature switches open at too low a temperature. 4. Overspeed module. 5. Switch and wiring. 	<ol style="list-style-type: none"> 1. Check oil, fresh water and sea water cooling. 2. Check for satisfactory operation with switch bypassed. 3. Same as above. 4. Check engine speed. Check module for proper operation. 5. Inspect all wiring for loose connections and short circuits.

Alternator not charging battery or battery runs down.

1. Alternator drive.	1. Check drivebelt and its tension. Be sure alternator turns freely. Check for loose connections.
2. Oil pressure switch.	2. Observe if gauges and light are on when engine is not running. Test the normally open oil pressure switch by disconnecting one lead. If lights go out, replace oil pressure switch.
3. High resistance leak to ground.	3. Check wiring. Insert sensitive (0-.25 amp) meter in battery lines. (Do not start engine.) Remove connections and replace each one until the short is located.
4. Low resistance leak to ground.	4. Check all wires for temperature rise to locate fault.

Fault

Possible Cause

Correction

Alternator not charging battery or battery runs down.
(continued)

5. Alternator.

5. Disconnect alternator at output, after a good battery charging. If leakage stops, replace alternator's protective diode plate. That failing, replace alternator.

6. Overspeed circuit drained battery.

6. Unit not run for months and fuse left in circuit drawing 0.025 amp.

DC Wire Sizing Chart

Stranded Conductors For 12 Volt Circuits
10% Voltage Drop

A. Society of Automotive Engineers Type Wire									B. National Electrical Code Type Wire								
Wire Size	18	16	14	12	10	8	6	4	16	14	12	10	8	6	4	2	1
Standing	16x30	19x29	19x27	19x25	19x23	19x21	49x23	49x21	19	19	19	19	19	37	61	127	127
Circular Mil Area	1537	2336	3702	5833	9343	14810	25910	37360	2583	4107	6530	10380	16510	26250	41740	66370	83690
Circuit Current in AMPS	MAXIMUM LENGTH OF CONDUCTOR IN FEET FROM POWER SOURCE TO LOAD AND RETURN																
1.	174	260							285								
2.	87	130							142	227							
3.	58	86.7	210	330					94.6	151	240						
4.	43.7	65	140	220					71	113	180	285					
5.	34.7	52	84	132	262	210			57	57	143	232					
6.	29	43.3	70	110	175	279			47.3	75.3	120	190	303				
7.	24.7	37	60	94	150	240			40.7	64.7	103	163	260				
8.	21.7	32.7	52.7	82.7	131	210			35.3	56.3	89.6	143	227				
9.	19.3	28.7	46.7	73.3	116	186	300		31.7	50.3	79.6	127	202	321			
10.	17.3	26	42	66	105	168	271		28.3	45.3	72	114	182	289			
15.		17.3	28	44	70	112	180	285	19	30	48	76	121	193	306		
20.			21	33	52.7	83.7	135	211		22.7	36	57	91	145	230		
30.				22	35	56	90.3	142			24	38	60.7	96.3	153	243	306
40.					26.3	42	67.3	107				28.3	45.3	72	115	182	230
50.					21	33.7	54	85.3				23	36.3	57.7	92	146	184
55.						30.7	49	77.7					33	52.3	83.3	133	167
60.							45	71.3						48	61	121	153
75.							36	57						38.3	51	81	123
90.								47.3									102

The voltage drop for specific conductor lengths may be calculated by the formula:

$$\text{Voltage drop} = \frac{10.75 \times I \times L}{\text{CM}}$$

I = load in amperes
where: L = conductor length in feet
CM = conductor circular MIL area

when a circuit, including the ground return, uses several different size conductors, the voltage drop at the electrical device is the sum of the drops calculated for each size segment of the circuit.

REMOTE PANEL INSTALLATION

INSTALLER'S/OWNER'S RESPONSIBILITY

1. Wiring between the generator set and either a remote start panel or remote instrument panel must comply with U.S. Coast Guard Safety Regulations 33 CFR-183.
2. The minimum voltage required at the starter solenoid is 9 volts. Therefore, wire gauges from TB1-1 to TB3-1 and from TB1-2 to TB3-2 should be selected to give a maximum voltage drop of 1 volt or less. This will provide 9 volts at the starter solenoid when battery terminal voltage is down to 10 volts, indicative of a deeply discharged battery.
3. Where #16 wire is shown in the table of Minimum Wire Gauges below, we recommend using #14 wire for greater strength and/or minimum voltage drops.

MINIMUM WIRE GAUGES (AWG)

Wire Length from Generator to Remote Panel

<u>Terminals</u>	<u>0-16'</u>	<u>16-20'</u>	<u>20-25'</u>	<u>25-32'</u>	<u>32-40'</u>	<u>40-50'</u>	<u>50-65'</u>
TB1-1 to TB3-1	#12	#10	#10	# 8	# 8	# 6	# 6
TB1-2 to TB3-2	14	12	12	10	10	9	8
TB2-1 to TB4-1	14	14	14	14	12	12	10
TB2-2 to TB4-2	14	14	14	14	14	14	14
TB2-3 to SENDER	14	14	14	14	14	14	14
TB2-4 to SENDER	14	14	14	14	14	14	14
TB2-5 to TB4-3	14	14	14	14	14	14	14

Refer to the wiring diagrams for the Remote Start/Stop Panel and Remote Instrument Panel.

The remote instrument panel has with it two sending units to be installed on the engine block. One, a water temperature sender and the other, an oil pressure sender. Plugged ports for each are located on the engine. The water temperature sender is installed in the thermostat housing and the oil pressure sender is installed adjacent to the oil pressure switch. Use sealing compound on the threads of both senders when installing. Electrical connections for each sender are tied off adjacent to each sender's location.

NOTE: The blue colored connection is for the oil pressure sender and the tan colored connection is for the water temperature sender.

GENERATOR DESCRIPTION AND MODEL RATING

Characteristics

Design: Brushless, four pole revolving field. Pre-lubricated, single bearing design. Reconnectable, single-phase transformer regulation.

Voltage Regulation: + 5 percent no-load to full-load.

Frequency Regulation: 3 hertz (5%) no-load to full-load.

Insulation: Class F as defined by NEMA MGI-1.65.

Temperature Rise: Within NEMA MGI-22.40 definition when operating at full-load.

Cooling: Centrifugal blower, directly connected.

Armature: Balanced laminated steel, double dipped and baked.

Ratings (Single Phase)

120/240 volts AC (60 hertz) or 220 volts (50 hertz) AC, single phase, 2 wire, 1.0 power factor, 1800 rpm at 60 hertz, 1500 rpm at 50 hertz.

<u>Model</u>	<u>Amp</u>	<u>Volt</u>	<u>Hertz</u>	<u>KW</u>
8.5 KW BTG (614)	70/35	120/240	60	8.5
6.8 KW BTG (514)	31	220	50	6.8
12.5 KW BTG (614)	104/52	120/240	60	12.5
10.0 KW BTG (514)	47	220	50	10.0
15.0 KW BTG (614)	125	120/240	60	15.0
12.0 KW BTG(514)	55	220	50	12.0

Deratings

A. 3.5 percent for each 1000 feet above sea level.

B. 1 percent for each 10° Fahrenheit above 85° F ambient.

C. 10 percent for continuous duty.

LAY-UP AND RECOMMISSIONING

General

Many owners rely on their boatyards to prepare their craft, including engines and generators, for lay-up during the off-season or for long periods of inactivity. Others prefer to accomplish lay-up preparation themselves.

The procedures which follow will allow you to perform your own lay-up and recommissioning, or to use as a check list if others do the procedures.

These procedures should afford your engine protection during a lay-up and also help familiarize you with the maintenance needs of your engine.

If you have any questions regarding lay-up procedures, call your local servicing dealer; he will be more than willing to provide assistance.

Fresh Water Cooling System

A 50-50 solution of antifreeze and fresh water is recommended for use in the fresh water cooling system at all times. This solution may require a higher concentration of antifreeze, depending on the area's winter climate. Check the solution to ensure that the antifreeze protection is adequate.

Should more antifreeze be needed, drain an appropriate amount from the engine block and add a more concentrated mixture. Operate the engine to ensure a complete circulation and mixture of the antifreeze concentration throughout the cooling system. Now recheck the antifreeze solution's strength at the manifold filler neck.

Lubrication System

With the engine warm, drain all the lubricating oil from the oil sump. Remove and replace the oil filter. (Place some paper towels and a plastic bag around the filter to catch the oil during its removal.)

When installing the new oil filter, be sure to apply a small amount of oil on the rubber sealing gasket at the base of the filter. Fill the sump with the correct amount of oil for your engine model. Use an oil with an API specification of SD, SE, SF or SG. Run the engine and check for proper oil pressure and ensure that there are no leaks.

CAUTION

Do not leave the engine's old lubricating oil in the sump over the lay-up period. Lubricating oil and combustion deposits combine to produce harmful chemicals which can reduce the life of your engine's internal parts.

Fuel System

Top off your fuel tanks with regular or unleaded gasoline with an octane rating of 89 or better. Fuel additives should be added at this time to control algae and condition the fuel. Care should be taken that the additives used are compatible with the primary filter/water separator used in the system. Change the element in your

primary fuel filter/water separator, if the fuel system contains one, and clean the separator sediment bowl. Clean the filter screen in the fuel lift pump and in the carburetor.

Sea Water Circuit

Close the thru-hull sea cock. Remove the sea water intake hose from the seacock. Place the end of this hose into a 5-gallon bucket of clean fresh water. Before starting the engine, check the zinc anode found in the primary heat exchanger on the engine and clean or replace it as required. Clean the sea strainer, if one is installed in the inside of the hull.

Start the engine and allow the sea water pump to draw fresh water through the system. When the bucket is empty, stop the engine and refill the bucket with an antifreeze solution slightly stronger than needed for winter freeze protection in your area.

Start the engine and allow all of this mixture to be drawn through the sea water system. Once the bucket is empty, stop the engine. This antifreeze mixture should protect the sea water circuit from freezing during the winter lay-up, as well as providing corrosion protection.

Remove the impeller from your sea water pump (some antifreeze mixture will accompany it, so catch it in a bucket). Examine the impeller. Acquire a replacement, if needed, and a cover gasket. **Do not** replace the impeller (into the pump) until recommissioning, but replace the cover and gasket.

Intake Manifold and Through-Hull Exhaust

Place a clean cloth, lightly soaked in lubricating oil, around the air arrester. Be sure to remove this cloth before recommissioning. Make a note to remove the cloth prior to start-up. The through-hull exhaust part can be blocked in the same manner.

Starter Motor

Lubrication and cleaning of the starter drive pinion is advisable, if access to the starter permits its easy removal. Ensure that the battery connections are shut off before attempting to remove the starter. Take care in properly replacing any electrical connections removed from the starter.

Cylinder Lubrication

Fogging the engine should be done as the last of the antifreeze mixture is drawn into the sea water circuit. Remove the air intake screen (the air filter) and spray Marvel Mystery Oil or another commercially available fogging oil into the carburetor while the engine is running. Spray enough oil to stall the engine. This will coat the walls of the cylinders, pistons, and valve surfaces with this protective oil. Remove the spark plugs and spray a small amount of this oil into each spark plug hole and turn the engine over two or three complete revolutions by hand. Reinstall, but do not tighten, the spark plugs, as these will need to be cleaned and gapped prior to recommissioning. Close off the carburetor's air filter with an oily rag.

Spares

Lay-up time provides a good opportunity to inspect the equipment to see if external items such as drive belts or coolant hoses need replacement. Check your basic spares kit and order items not on hand, or replace those items used during the lay-up, such as filters and zinc anodes.

Batteries

If batteries are to be left on board during the lay-up period, ensure that they are fully charged, and will remain that way, to prevent them from freezing. If there exists any doubt that the batteries will not remain fully charged, or that they will be subjected to severe environmental conditions, remove the batteries and store them in a warmer, more compatible environment.

Recommissioning

The recommissioning of your Westerbeke unit after a seasonal lay-up generally follows the same procedures as those presented in the "PREPARATION FOR STARTING" section, regarding preparation for starting and normal starts. However, some of the lay-up procedures will need to be counteracted before starting the engine.

1. Remove the oil-soaked cloths from the intake manifold and from the through-hull exhaust port.
2. Remove the sea water pump cover and gasket. Discard the gasket. Install the sea water pump impeller removed during lay-up (or a replacement, if required). Install the sea water pump cover with a new cover gasket.

WARNING

Wear rubber gloves, a rubber apron, and eye protection when servicing batteries.

Lead acid batteries emit hydrogen, a highly-explosive gas, which can be ignited by electrical arcing or a lighted cigarette, cigar, or pipe. Do not smoke or allow an open flame near the battery being serviced. Shut off all electrical equipment in the vicinity to prevent electrical arcing during servicing.

3. Reinstall the batteries that were removed during the lay-up, and reconnect the battery cables, making sure the terminals are clean and that the connections are tight. Check to ensure that the batteries are fully-charged.
4. Check the condition of the zinc anode in the sea water circuit and clean or replace the anode as needed. Note that it is not necessary to flush the antifreeze/fresh water solution from the sea water coolant system. When the unit is put into operation, the system will self-flush in a short period of time with no adverse affects.
5. Start the unit in accordance with those procedures found in the "STARTING PROCEDURE" section of this manual.

FIELD FABRICATED TOOLS

The mechanical drawings that follow provide a means by which simple tools can be made to assist in the removal of the generator end from the engine and in the replacement of the generator end on the engine. A local machine shop should be able to manufacture these tools at a modest price, but first check with your local Westerbeke dealer to see if these tools are on hand for loan.

The tool below helps keep the rotor from damaging the windings in the generator housing by allowing the generator housing to be removed straight off the engine or to be placed straight on the engine. Refer to the removal and replacement diagram on the next page.

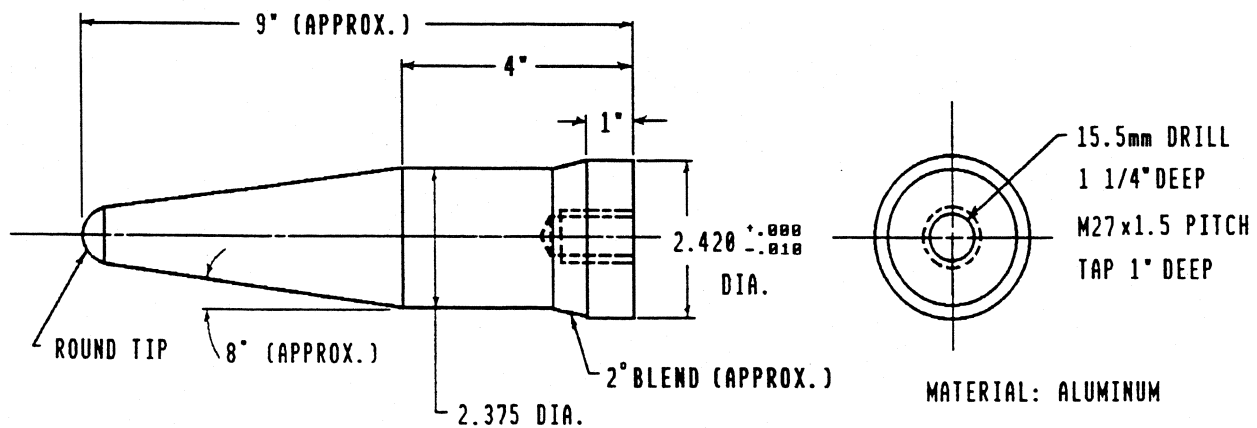
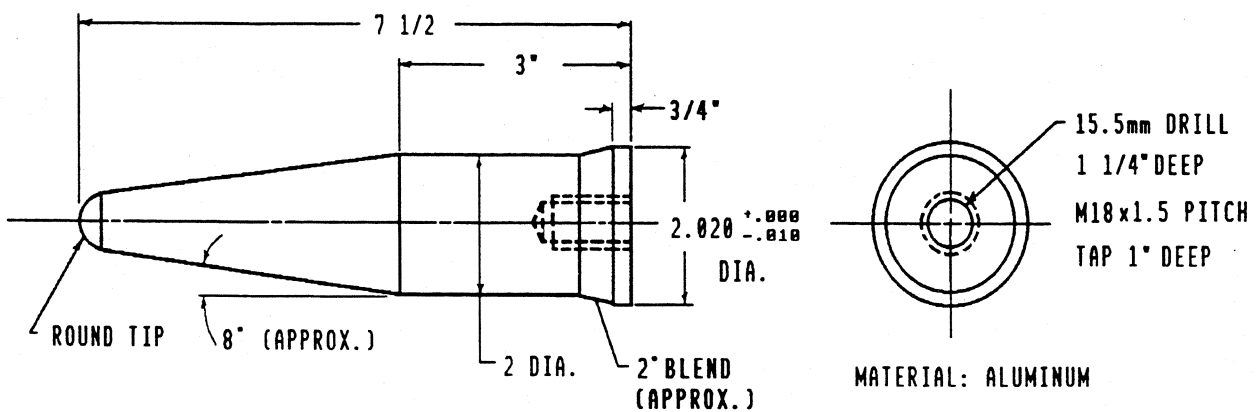

This tool allows the generator housing to be either removed or replaced without damaging the generator windings.

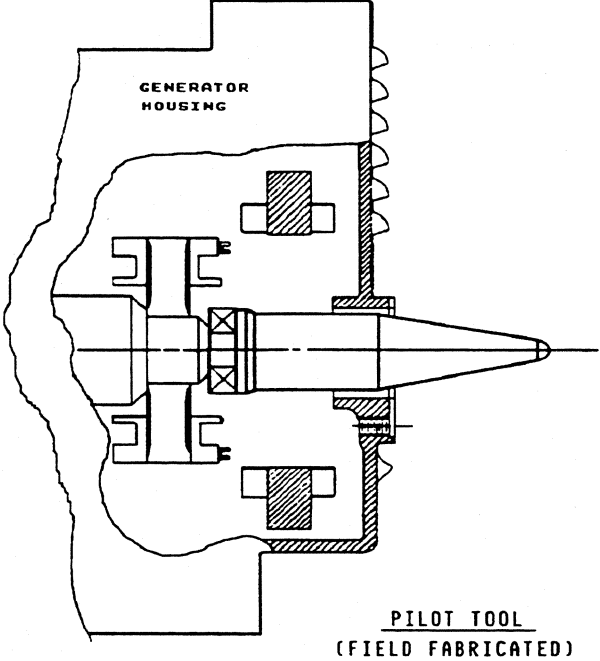

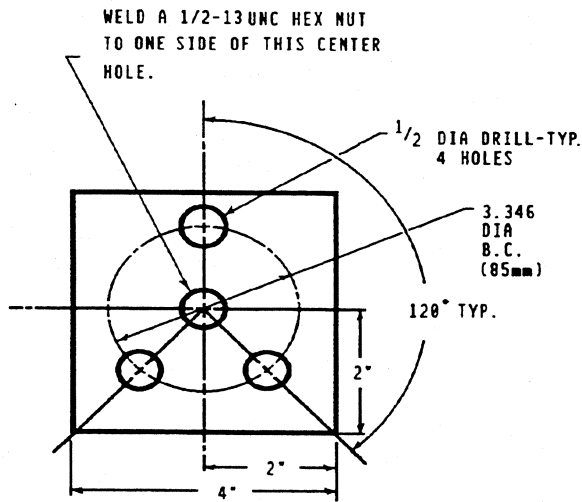

MATERIAL: COLD ROLLED STEEL

HOUSING PULLER TOOL
(FIELD FABRICATED)

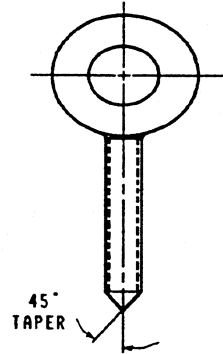
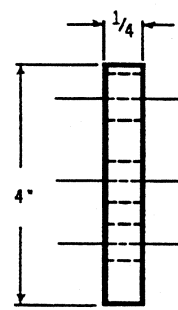

1/2-13UNC STORE-BOUGHT EYE BOLT WITH TAPERED TIP.

This tool allows the bearing in the generator housing to be gently pushed straight off the housing without any twisting. If a nut of the same specifications as that of the tapped hole in the pilot tool were to be welded on the end of the eye bolt, this tool would be able to pull the bearing back into place without any twisting. Please refer to these drawings before the generator end is removed.

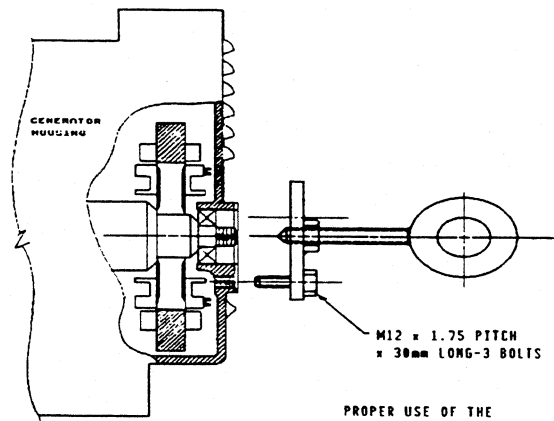

This tool allows a mechanic to safely remove the generator end from the engine by attaching this Generator End Lifting Eye to the four screw holes located under the control panel. To use this Lifting Eye, remove the generator's control panel and screw the Lifting Eye to the generator end.

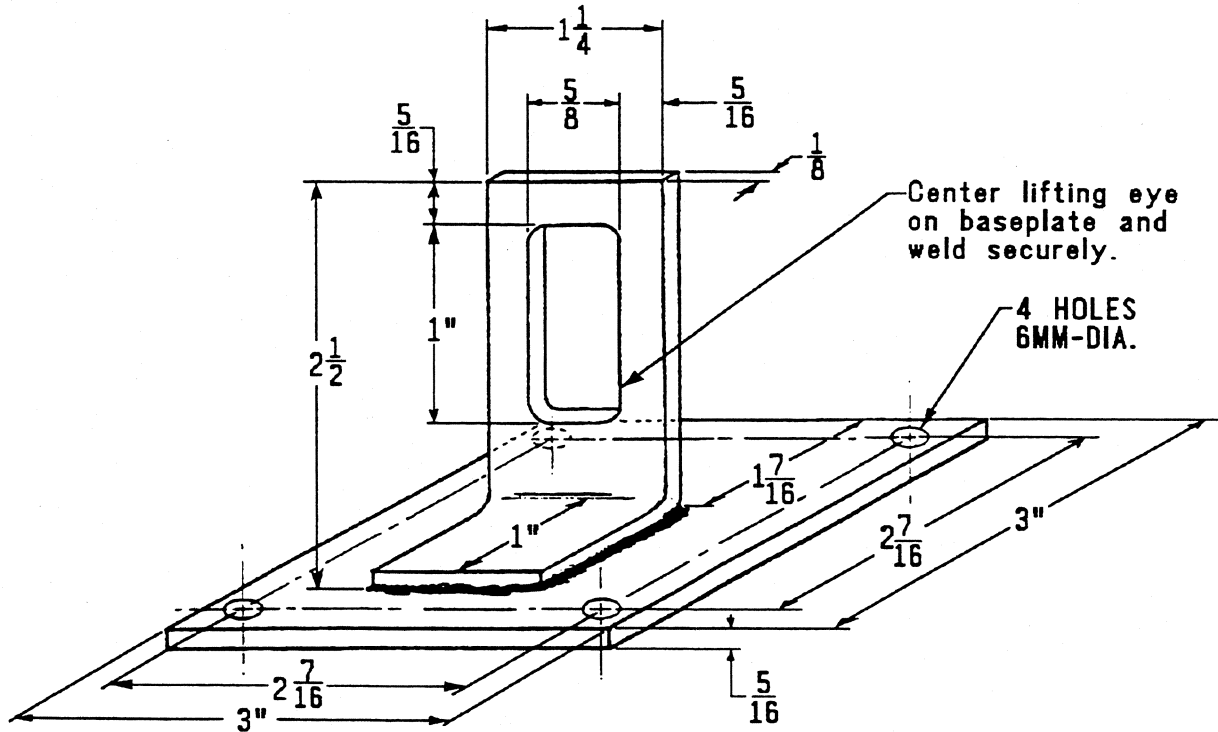

This tool allows a mechanic to safely remove and install the generator drive disks by aligning the disks with this Drive Plate Guide Pin. The pin screws into the flywheel and acts as a guide. Also the pin helps to support some of the rotor and drive plates weight while removing or replacing these parts.

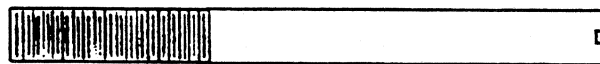

Material: One M8 bolt with the hex head machined off and a screw driver slot cut in the machined end.

NOTES

TROUBLESHOOTING THE BT GENERATOR

BTG 8.5KW (12 Terminal Block),
BTG 12.5KW, and the BTG 15.0KW (6 Terminal Block)

The following trouble shooting guide is designed to give insight into problems which may be encountered with the Westerbeke brushless transformer generator. Owing to the simplicity of the equipment and controls, troubleshooting is relatively easy, once the relationship between cause and effect is understood.

Most potential problems are covered in the text of this guide; however, should an omission or an error be found, we would greatly appreciate your notifying us of it.

Keep in mind that a basic fundamental knowledge of electricity is required for this troubleshooting, and always remember that lethal voltages are present in the circuitry; therefore, extreme caution is essential when working on or troubleshooting a generator.

Only a few basic tools are necessary for diagnosis and repair, such as an amp-probe and a quality volt-ohmmeter capable of reading less than one ohm (Ω) due to the precision required in reading component winding resistances.

NOTE: Do not always rely on the vessel's instruments for accurate readings; try to bring your own.

Before attempting any repairs, get as clear an explanation of the problem as possible, preferably from an individual witnessing the problem. In some cases, this may bring to light a problem which is related to the method of operation rather than equipment fault.

Bring basic repair parts with you on the initial trip to the problem equipment, such as diodes and a bridge rectifier, so that if the problem should be found in one of these easily replaceable parts, the problem can be remedied early and efficiently.

The internal and external wiring diagrams are important tools in troubleshooting this generator or any generator model.

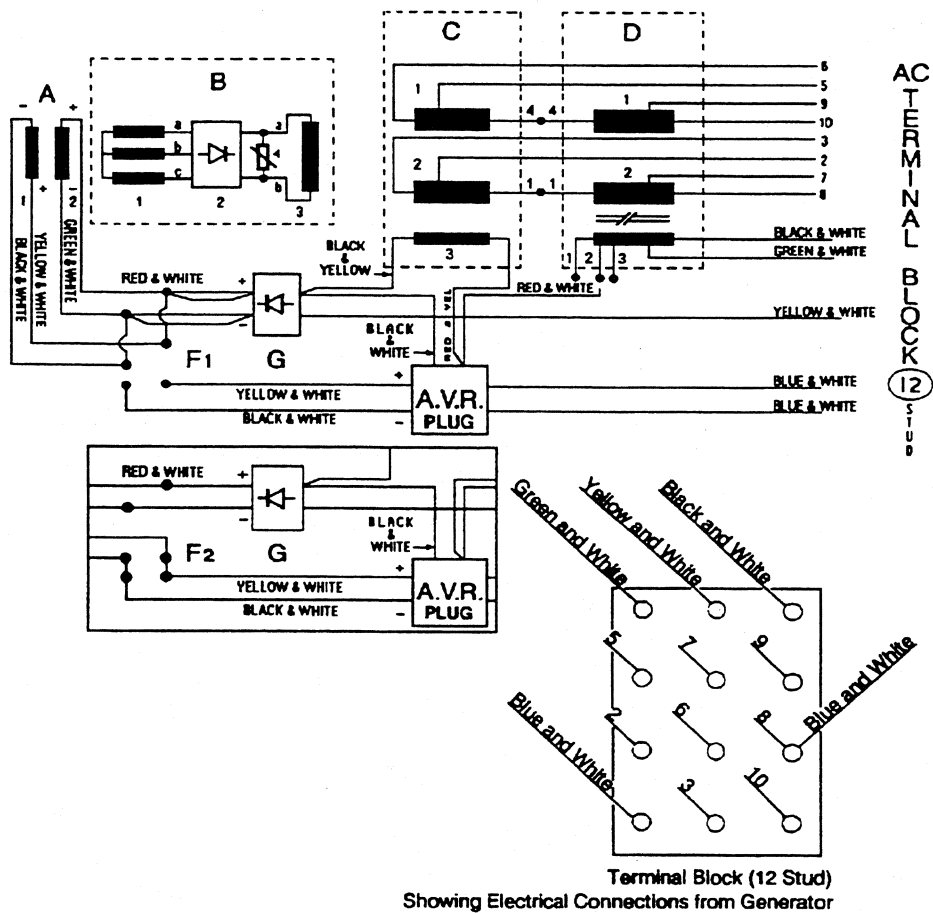

A.V.R. - Automatic Voltage Regulator
(Early Models)

12 Terminal Block
INTERNAL WIRING SCHEMATIC

A. EXCITER STATOR WINDINGS

1. Exciter Stator Windings
(Selector in Electronic)
2. Exciter Stator Windings
(Selector in Compound)

B. EXCITER ROTOR

1. Auxiliary Windings (a - b - c)
2. Diodes (6)
3. Rotating Field Windings
4. Pozi Resistor

C. MAIN STATOR

1. Main Stator Windings
2. Main Stator Windings
3. Main Stator Auxiliary Windings

D. COMPOUND TRANSFORMER

1. Compound Transformer Windings
2. Compound Transformer Windings
3. Compound Transformer Auxiliary Windings

E. SELECTOR SWITCH (Early Models)

1. Compound
2. Electronic and Compound

G. BRIDGE RECTIFIER

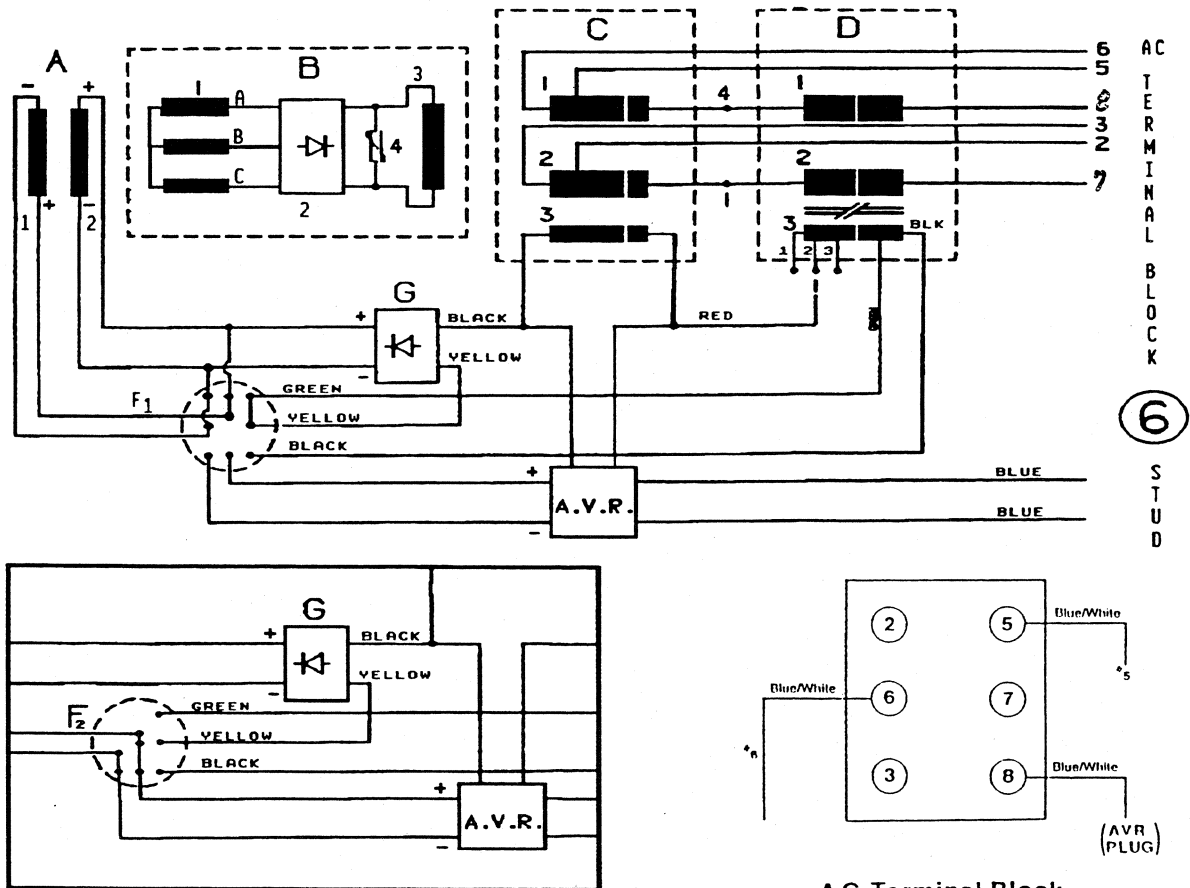

A.V.R. - Automatic Voltage Regulator

6 Terminal Block
INTERNAL WIRING SCHEMATIC

A. EXCITER STATOR WINDINGS

1. Exciter Stator Windings (Selector in Electronic)
2. Exciter Stator Windings (Selector in Compound)

B. EXCITER ROTOR

1. Auxiliary Windings (a - b - c)
2. Diodes (6)
3. Rotating Field Windings
4. Pozi Resistor

C. MAIN STATOR

1. Main Stator Windings
2. Main Stator Windings
3. Main Stator Auxiliary Windings

D. COMPOUND TRANSFORMER

1. Compound Transformer Windings
2. Compound Transformer Windings
3. Compound Transformer Auxiliary Windings

E. SELECTOR SWITCH (Early Models)

1. Compound
2. Electronic and Compound

G. BRIDGE RECTIFIER

1. The amount of no-load voltage produced by the generator can be an indicator of where in the generator the problem/fault may lie.

Residual Voltage 18 - 22 volts AC

This voltage is the AC voltage produced by the generator from magnetism in the exciter stator field. This voltage is measured between the Neutral and Hot leg(s) with no-load on the generator, while the generator is running at its rated rpm.

The presence of residual voltage is an indication that the following generator components are OK .

1. Exciter Rotor (B-1)
2. Rotating Field (B-3)
3. Main Stator (C-1 and C-2)
4. Compound Transformer (D-1 and D-2)

The fault lies in one or more of the following components in the exciter circuit:

- A. Exciter Stator (A-1 & A-2)
- B. Bridge Rectifier (G)
- C. Selector Switch (F)
- D. Main Stator Auxiliary Windings (C-3)
- E. Compound Transformer Auxiliary Winding (D-3)

2. Nine (9) volt DC excitation of the exciter stator windings, selector switch in the **COMP** position, should cause the generator to produce between 125 - 135 volts AC between the single 120 volt leg and neutral or 65 - 70 volts AC between each 120 volt leg and neutral. (Twelve volts DC is applied between the lifted (+) and (-) leads of the bridge rectifier, + to + and - to - .) Correct voltage produced with nine volts DC excitation indicates the fault is in one or more of the above listed components B, D or E. If the generator does not produce 125 - 135 volts AC, then include A and C.

The following is a list of faults with the generator operation on compound (**COMP**) transformer regulation. (No A.V.R. installed) N/L = no-load.

<u>Fault</u>	<u>Possible Cause</u>	<u>Correction</u>
Correct voltage at N/L and loss of voltage as load is applied. (No loss of engine speed and hertz.)	1. Selector switch in wrong position.	1. Place selector switch in COMP position.
High voltage at N/L with correct voltage at F/L.	1. Generator's engine speed (rpm) high at N/L. 2. Winding of Exciter Stator windings A-2 open.	1. Check N/L and adjust voltage. 2. Check continuity and connections of A-2 windings.
High voltage at N/L and F/L.	1. Generator's engine speed (rpm). 2. Short in compound transformer auxiliary windings D-3.	1. Check N/L rpm and adjust N/L voltage. 2. Check continuity and connections of D-3 windings.
Low voltage at N/L (0 - 50 volts) with growling noise from generator and loss of engine speed when load is applied.	1. Main stator windings shorted C-1, C-2.	1. Check continuity and resistance values of C-1, C-2 windings and connections.
Generator does not excite; voltage is 0 volts at N/L.	1. Generator's engine speed (rpm) is slow. 2. Short in diode(s) of exciter rotor (B-2).	1. Adjust engine's speed and adjust N/L voltage. 2. Check diodes as described in this manual.

<u>Fault</u>	<u>Possible Cause</u>	<u>Correction</u>
Low voltage at N/L; when load is applied, voltage drops.	<ol style="list-style-type: none"> 1. Diode(s) in rotating exciter (B-2)shortened 2. Bridge rectifier defective. 3. Auxiliary windings B-1 shorted. 4. Auxiliary windings D-3 and /or C-3 open. 	<ol style="list-style-type: none"> 1. Check diodes in rotating exciter as explained in this manual. 2. Follow test procedure for bridge rectifier. 3. Check continuity and resistance values. 4. Check continuity and resistance values of windings and connections.
Low voltage at N/L and F/L 50 - 70 volts.	<ol style="list-style-type: none"> 1. Selector switch in ELEC position. 2. Exciter stator windings A-2 open. 3. Generator's engine speed (rpm) is low. 	<ol style="list-style-type: none"> 1. Place switch in COMP position. 2. Check continuity and resistance values of A-2 windings. 3. Check generator N/L rpm and adjust N/L voltage.
Voltage correct at N/L but at F/L with loss of engine rpm (hertz).	<ol style="list-style-type: none"> 1. Generator overload. 2. Low power factor load (motor loads). 	<ol style="list-style-type: none"> 1. Check data plate and monitor load on generator with amp-probe. 2. Check type of load applied. Consider use of optional regulator board.
Unstable voltage.	<ol style="list-style-type: none"> 1. Engine's rpm fluctuating. 	<ol style="list-style-type: none"> 1. Check engine operation and fuel system.

The following is a list of faults with the generator operating on electronic (ELEC) regulation. Selector switch is in the ELEC position with an A.V.R installed.

<u>Fault</u>	<u>Possible Cause</u>	<u>Correction</u>
Voltage correct at N/L and loss of voltage at F/L.	1. Diode in exciter rotor B-2 shorted.	1. Check diodes as explained in this manual.
High voltage at N/L with no adjustment from regulator potentiometer.	1. Regulator board defective.	1. Replace regulator board. Adjust N/L voltage with transformer; then switch to ELEC and adjust with A.V.R potentiometer.
Low voltage at N/L and F/L. No adjustment from regulator board potentiometer.	1. Regulator board defective.	1. Replace regulator board and adjust voltage as above.
	2. Exciter stator winding A-1 open.	2. Check resistance values of C-3 and D-3 windings and their connections.
Low voltage at N/L (0 - 50 volts) with growling noise from generator and loss of engine speed when load is applied.	1. Main stator windings shorted, C-1,C-2.	1. Check continuity and resistance values of C-1 and C-2 windings and their connections.
Generator does not excite; 0 volts at N/L.	1. Diode(s) in exciter rotor shorted (B-2).	1. Check diodes in exciter rotor as illustrated in this manual.
	2. Generator's speed is low.	2. Check the engine's speed (hertz).

<u>Fault</u>	<u>Possible Cause</u>	<u>Correction</u>
Low voltage at N/L and voltage drops further as a load is applied.	1. Diodes in exciter rotor shorted (B-2).	1. Check diodes in exciter rotor as illustrated in this manual.
	2. Auxiliary windings in exciter rotor shorted (B-2).	2. Check resistance values and continuity to ground.
Voltage OK at N/L and low at F/L.	1. Auxiliary windings in the exciter rotor B-1 shorted.	1. Check resistance values and continuity to ground.
	2. Exciter stator compound winding A-2 open.	2. Check continuity and connection of windings.
	3. Auxiliary winding D-3 or C-3 open.	3. Check continuity and connection of winding.
Voltage unstable.	1. Defective regulator board.	1. Check stability of DC voltage from regulator to exciter stator windings. Operate unit on COMP . Replace regulator board.
Voltage unstable.	1. Engine is hunting.	1. Check engine operation and fuel system.
	2. Electrical connections.	2. Check for clean and secure connections.

Bridge Rectifier

The bridge rectifier is supplied AC voltage from the auxiliary windings in the generator stator (C-3) and the compound transformer (D-3). The AC voltage measured across the AC terminals of the rectifier during engine operation is listed below.

120 Volts

N/L F/L
11 - 21 Volts AC

120/240

N/L F/L
11 - 21 Volts AC

Diodes in the rectifier convert this AC voltage to DC and supply it to the windings (A-2) of the exciter stator to induce a field through which the exciter rotor revolves. The DC voltage measured across the (+) and (-) terminals of the bridge rectifier during engine operation is listed below.

120 Volts

N/L F/L
8 - 17 Volts DC

120/240

N/L F/L
8 - 17 Volts DC

Failure of the bridge rectifier will result in no strong field being produced by the exciter stator windings. A weak field is present, due to the magnetism in the exciter stator, which will cause the generator to produce residual voltage as discussed earlier in this text.

Testing the Bridge Rectifier for Fault(s) with an Ohmmeter

NOTE: Different analog and digital meters will produce opposite test results and varied ohm readings for the diodes.

- (1) Set ohmmeter scale on Rx1 (+ DC). Zero the meter.
- (2) Connect the (+) lead from the meter to Point #4. Momentarily contact points #1, #2, #3 and #5 with the (-) lead from the meter. No deflection of the needle should occur. This shows infinite resistance.
- (3) Remove the (+) lead from Point #4 and connect the (-) lead to Point #4 and, with the (+) lead, momentarily touch Points #1, #2 and #3. Points #1 and #3 should show an 8 ohm resistance \pm 2 ohm. Point #2 should show a 40 ohm resistance \pm 5 ohm.
- (4) Touch Point #5 with the (+) lead. No deflection of the needle should occur.
- (5) Place the (+) lead of the meter on Point #1 and the (-) on Point #3. No deflection of the needle should occur (infinite resistance). Reverse the connections and the same should occur.

Should the rectifier fail any of the above tests, it is defective and should be replaced.

RESISTANCE VALUES - at 70° F (21° C). (Values taken using Simpson #260 analog style meter.)

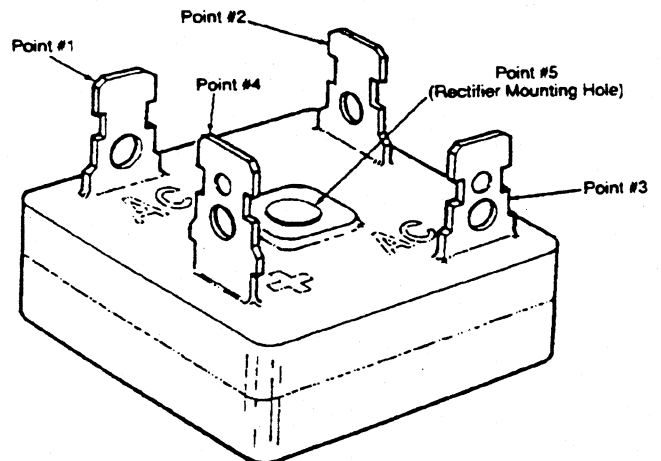

A. EXCITER STATOR WINDINGS

Resistance Values (Comp F1)

- 8.5 BTG 8.5 - 9.0 ohm.
- 12.5 and 15.0 BTG 12.5 - 13.0 ohm.

Readings are taken with selector switch in the COMP position between the positive (+) and negative (-) leads lifted off the bridge rectifier.) Neither of these two leads should have continuity to the case/ground.

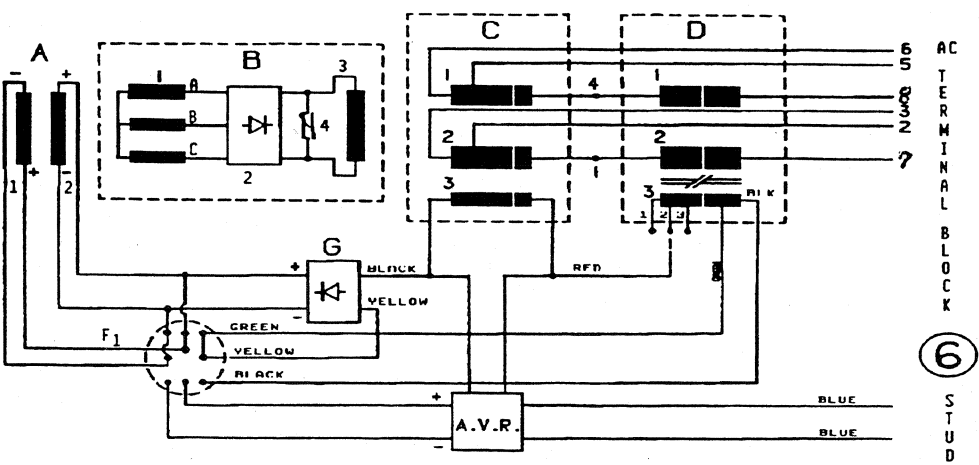
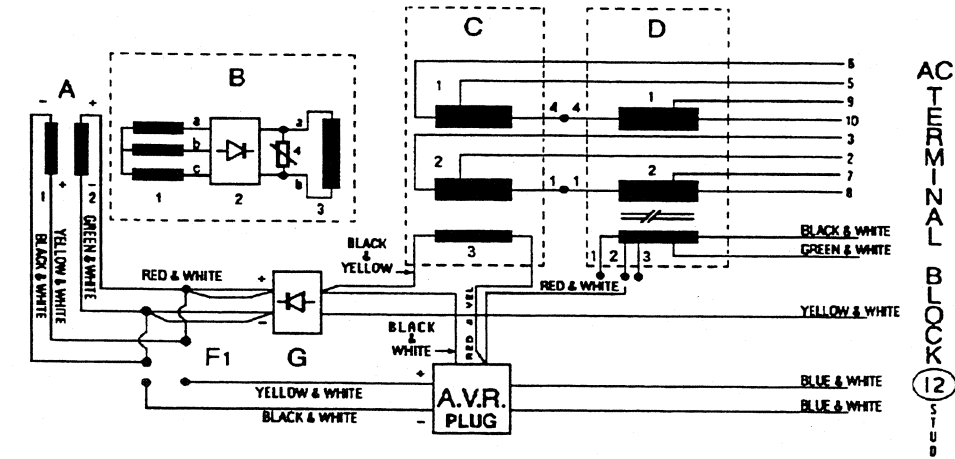

B. EXCITER ROTOR

1. Auxiliary Winding Resistance Values

8.5 BTG	1.1 ohm.
12.5 and 15.0 BTG	1.05 ohm.

(Readings are taken between each pair of windings a + b, b + c, and c + a.) Leads can be left attached to their connection points on the rotor. There should be no continuity to the rotor shaft between either of these three points.

2. Diodes (six are mounted around the circumference of the exciter rotor.) These rectify the AC voltage produced by the three groups of auxiliary windings to DC voltages and supply this DC voltage to the rotating field windings B-3.

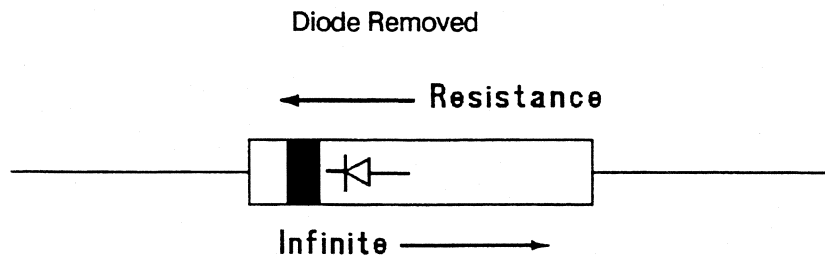

The diodes can be easily checked in place with the use of a common automotive 12 volt, high beam headlight bulb, some jumper leads and the generator's 12 volt starting battery.

A short or an open in a diode can easily be found with the above without having to unsolder and isolate each diode to check it with an ohmmeter.

NOTE: Attempting to check diodes in place with an ohmmeter will give erroneous readings on the diodes due to the auxiliary windings connections.

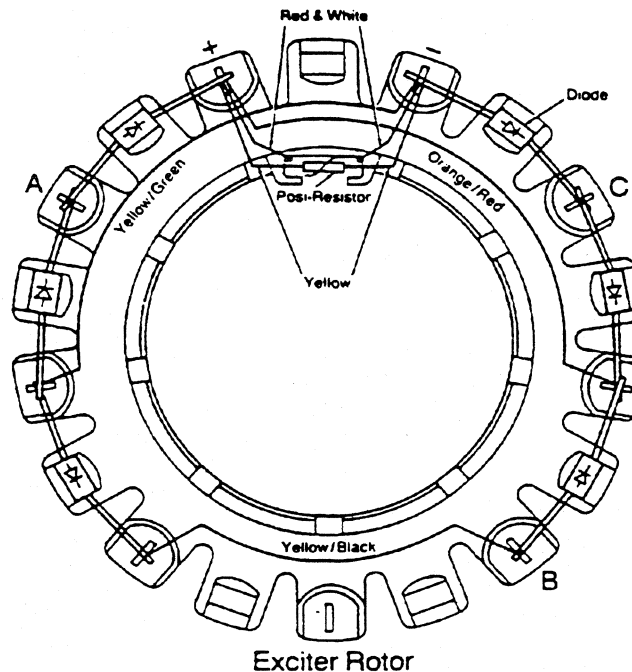

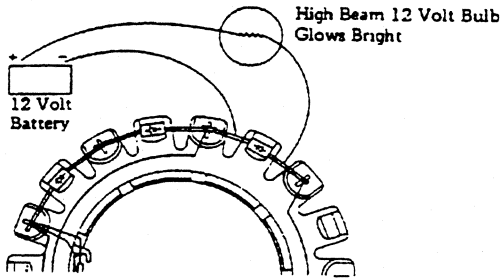

3. When leads are put across the diode, as illustrated, voltage passes through the diode allowing the headlight to glow brightly.

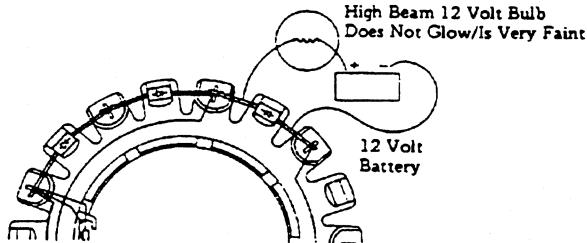

4. Reverse the leads across the diode. The diode should block voltage passing through it and the head light should not glow, or it may glow faintly.

A. Should the bulb not glow with leads connected in both directions, the diode is open internally.

B. Should the bulb glow bright with the leads connected in both directions, the diode is shorted internally.

In both A and B above, the diode should be replaced. Check resistance values of rotating field windings and the integrity of the resistor connected between field windings.

5. Rotating Field Windings.

Resistance Values

8.5 BTG	7.3 ohm.
12.5 BTG	8.7 ohm.
15.0 BTG	8.9 ohm.

(Readings are taken between the two red and white striped wires connected to the (+) and (-) terminals on the exciter rotor as shown on the exciter rotor illustration.)

NOTE: These terminals are not marked (+) and (-); there should be no continuity to the rotor shaft/ground through either of the two connections.

6. Posi-Resistor. (Infinite readings between both yellow leads lifted from terminals (+) and (-) of the rotating field connections on the exciter rotor.) Refer to the exciter rotor illustration. The posi-resistor is sandwiched in an insulated portion of the exciter rotor and should have no contact with the ground.

C. MAIN STATOR WINDINGS

Resistance Values

8.5 BTG	0.21 ohm (each group).
12.5 BTG	0.117 ohm (each group).
15.0 BTG	0.089 ohm (each group).

Group 1 - measured between lead #6 at the AC terminal block and lead #4 at the junction block. Lift both leads, along with lead #5 at the terminal block, to totally isolate group #1.

Group 2 - measured between lead #3 at the AC terminal block and lead #1 at the junction block. Lift both leads, along with lead #2 at the terminal block, to totally isolate group #2

NOTE: The Junction Block for connections #4 and #1 from the main stator windings and to the transformer windings is found just below and to the left of the compound transformer.

12.5 and 15.0 BTG Stator Group 1 + 2

Group 1 - Measure the resistance between lead #6 lifted from the AC terminal block and lead #4 lifted off the red terminal isolator below the the transformer. Lift lead #5 off the AC terminal block to totally isolate stator group C-1.

Group 2 - Measure the resistance between lead #3 lifted from the AC terminal block and lead #1 lifted off the red terminal isolator below the transformer. Lift lead #2 off the AC terminal block to totally isolate stator group C-2.

Main Stator Auxiliary Windings.

Resistance Values

8.5 BTG	1.6 ohm.
12.5 BTG	0.99 ohm.
15.0 BTG	0.85 ohm.

8.5 BTG - Measure the resistance value between the lifted double lead connection from one of the AC terminals of the bridge rectifier and the double lead central prong connection of the plug for the voltage regulator.

12.5 and 15.0 BTG - Measure the resistance value between the lifted double lead connection from one of the AC terminals of the bridge rectifier and the lifted yellow and red striped wire from the Voltage/Hertz Connections Bar found just to the lower left of the AC terminal block.

NOTE: No continuity should be found between any of these main stator and auxiliary winding groups and the case ground, or between each group when leads are lifted to isolate them.

D. COMPOUND TRANSFORMER

Resistance Values (Group 1 + 2)

8.5 BTG	0.0197 ohm (each group).
12.5 and 15.0 BTG	0.007 ohm (each group).

1. 8.5 BTG (Group 1 + 2).

Group 1 - Measured between lead #10 at the AC terminal block and lead #4 at the junction box. Lift both leads along with lead #9 at the terminal block.

Group 2 - Measured between lead #8 at the AC terminal block and lead #1 at the junction block. Lift both leads along with lead #7 at the terminal block.

2. 12.5 and 15.0 BTG (Group 1 + 2).

Group 1 - Measure the resistance value between lead #4 lifted off the red isolator terminal found below the transformer and lead #8 lifted off the AC terminal block.

Group 2 - Measure the resistance value between lead #1 lifted off the red isolator terminal found below the transformer and lead #7 lifted off the AC terminal block.

3. Transformer Auxiliary Windings.

Resistance Values

8.5 BTG	4.27 ohm.
12.5 and 15.0	5.02 ohm.

8.5 BTG Transformer Auxiliary Windings

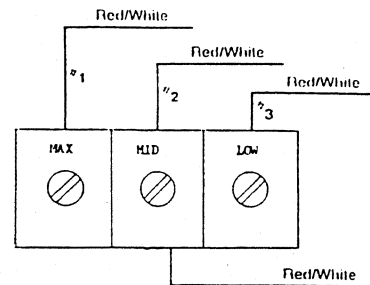

A three connection terminal strip is located just below the AC terminal block at the lower left. Isolate the three numbered #1, #2, and #3 red and white-striped wires coming onto each of the three terminals. Lift the black and white and green and white leads off their connections on the AC terminal block. Measure the resistance value between the #1 red and white lead lifted from the terminal strip and the black and white lead lifted from the AC terminal block.

NOTE: The three connection terminal strip is for the increase or decrease of full-load voltage output. Should full-load voltage fall below 108 volts, selecting a higher number terminal strip lead to connect the lead (red and white) that is routed to the regulator plug and the exciter circuit will supply a higher AC voltage to the exciter circuit during full-load conditions, bringing the output voltage of the generator up.

No-load voltage should be properly adjusted by shimming the compound transformer: 121 - 124 volts at 61.5 - 62.0 hertz. Note that the above should not be used as a means of compensating for incorrectly adjusting the generator's no-load voltage.

12.5 - 15.0 BTG Transformer Auxiliary Windings

A five connection terminal strip is located just below the AC terminal block at the lower left. Isolate the three #1, #2, and #3 red and white-striped leads coming to one side of this strip by lifting them from this

strip. Note these leads are numbered #1, #2, and #3. With the selector switch in ELEC, lift the single lead off the AC terminal of the bridge rectifier (yellow-white striped lead). Measure the resistance value between this lead and the #1 red/white striped lead lifted off the connecting bar.

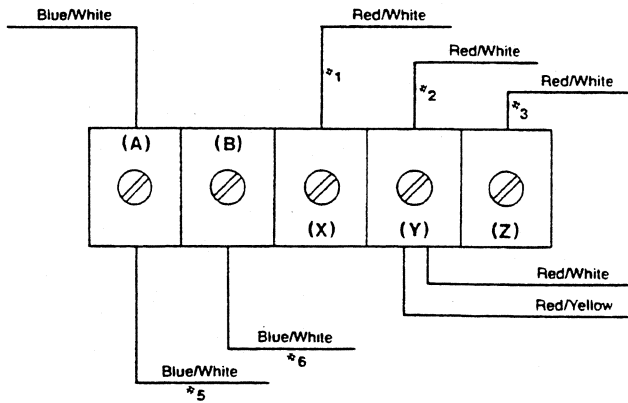

12.5 BTG and 15.0 BTG

Voltage/Hertz Connection Bar

E. SELECTOR SWITCH

1. Selector Switch in Compound.
2. Selector Switch in Compound with A.V.R.

The selector switch is located behind the generator's louvered back cover at the 12 o'clock position. Standard regulation is with the compound transformer (COMP position for the switch). An optional solid state voltage regulator is available for early models. When installed, the switch can be moved to the ELEC position. The switch *must* be in the COMP position when no optional A.V.R. is installed, otherwise low output voltage will result.

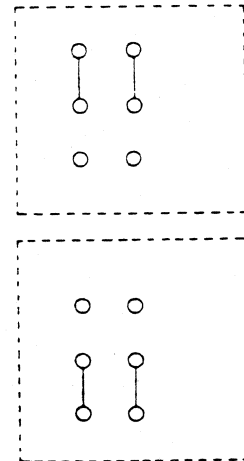

F. BRIDGE RECTIFIER WIRING

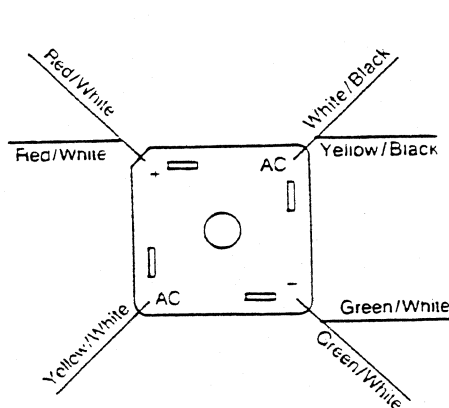

8.5 BTG

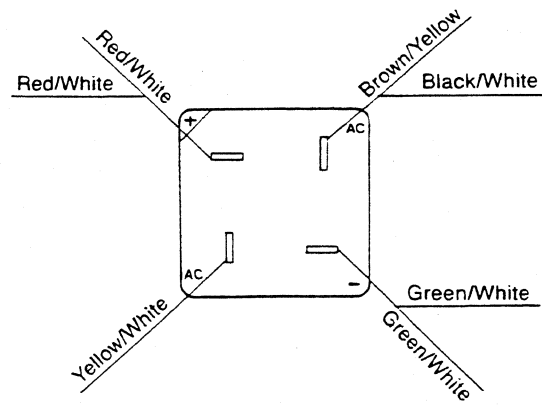

12.5 and 15.0 BTG

No Load Voltage Adjustment

Voltage adjustment is made with the generator regulation being governed by the compound transformer.

1. The selector switch must be in the **COMP** position.
2. Operate the generator and apply a moderate load momentarily and remove it. Note the voltage output from the generator's 120 volt leg(s) (110 volt 50 hertz). The no-load voltage should be between 121 - 124 volts at 61.5 - 62 hertz (111 - 113 volts at 51.5 - 52 hertz).

NOTE: The no-load voltage should be adjusted to the voltage produced by the generator, once started, and a momentary load applied to excite the transformer and then removed. The voltage produced by the generator after this momentary load is removed is no-load voltage.

3. To raise or lower the voltage, shims of varying thickness (non-conductive material) are placed or removed from under the steel laminated bar on top of the compound transformer. The material used for shimming should not soften at temperatures in the 176° F (80° C) range. A small reduction in no-load voltage (1 to 3 volts) can sometimes be accomplished by gently tapping the top of the laminated steel bar to reduce the air gap between the existing shims and the transformer core.

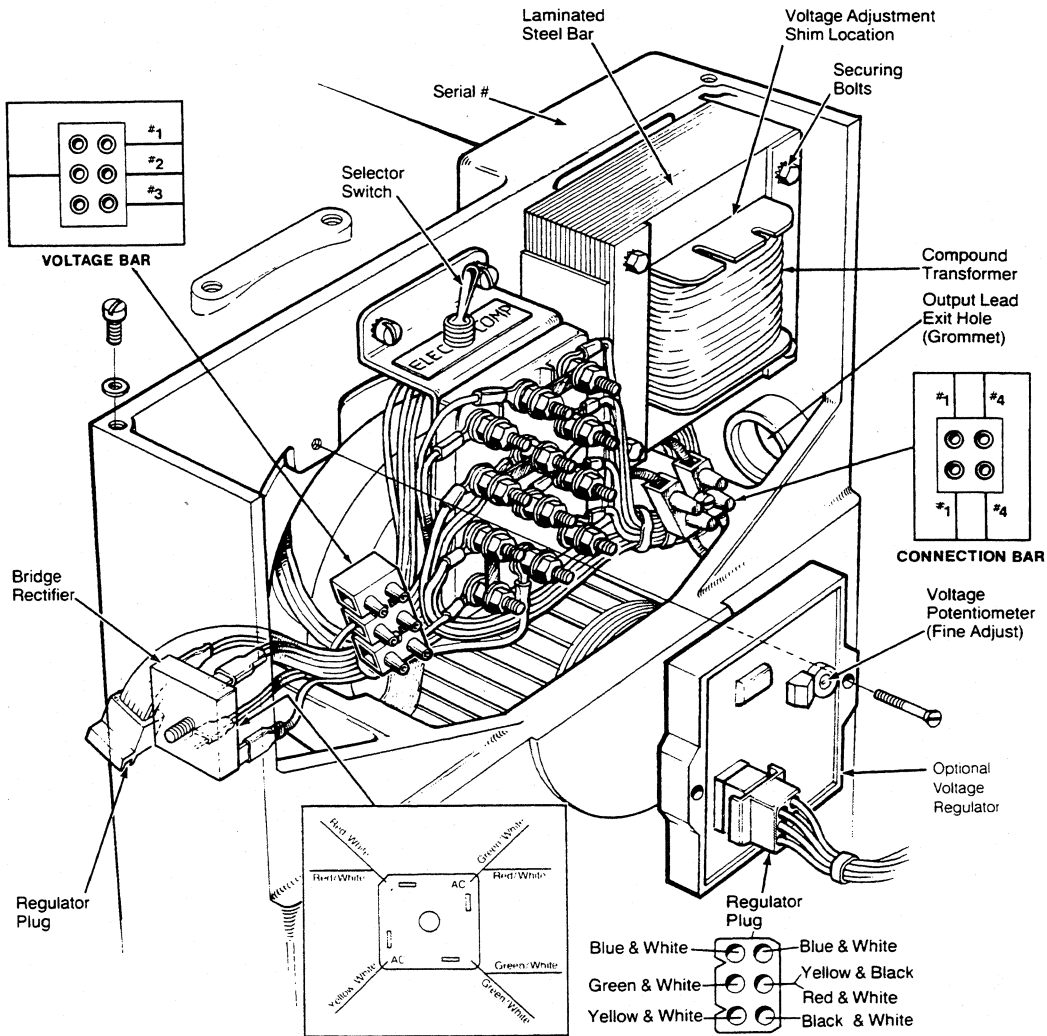

8.5 BTG (Exposed back end with louvered cover removed).

CAUTION

Under no circumstances attempt to increase the no-load voltage by increasing the gap between the laminated steel bar and the transformer core without the use of shims. Magnetic forces created within the transformer during generator operation may close the air gap and reduce no-load voltage output.

4. To remove the laminated steel bar, remove the two upper securing bolts from the compound transformer and lift the bar from the transformer. The addition of shim thickness will raise the no-load voltage and, conversely, the removal of shim thickness will lower the no-load voltage.

Varying shim thickness by .001 inch (0.025 mm) will change the no-load voltage by 4 to 6 volts. (Shim material should be non-conductive; that is, it should be transparent or colored stationary store material.)

Optional Voltage Regulator (Early Models)

An optional solid state voltage regulator board #34410 is available for use with the BT generator. When this board is installed and the regulation switch is moved to the ELEC position, the regulator works together with the standard compound transformer regulator to regulate generator voltage output. Refer to the wiring diagrams.

Installation

1. The regulator is mounted using existing tapped holes in generator case. Use (2) M4 x 0.7 millimeter screws, each 15 mm long, with lock washers to mount the regulator board.
2. Take the 6-prong generator plug and plug it into the receptacle on the regulator board.

NOTE: The plug is shaped so it will only engage in the regulator's receptacle in one direction. Check this and insert correctly.

3. Before moving the selector switch to ELEC, ensure the no-load voltage produced by the generator is properly adjusted with the selector in COMP position, following procedures for no-load voltage adjustment.
4. With generator no-load voltage properly adjusted to 112 - 116 volts, move the selector switch into the ELEC position. Adjust the regulator board potentiometer to set no-load voltage at 120 volts, 61.5 - 62 hertz (110 volts, 51.5 - 52 hertz). Generator voltage output should be within ± 5 percent from no-load to full rated generator output.

BT GENERATOR 12 TERMINAL BLOCK AC VOLTAGE CONNECTIONS

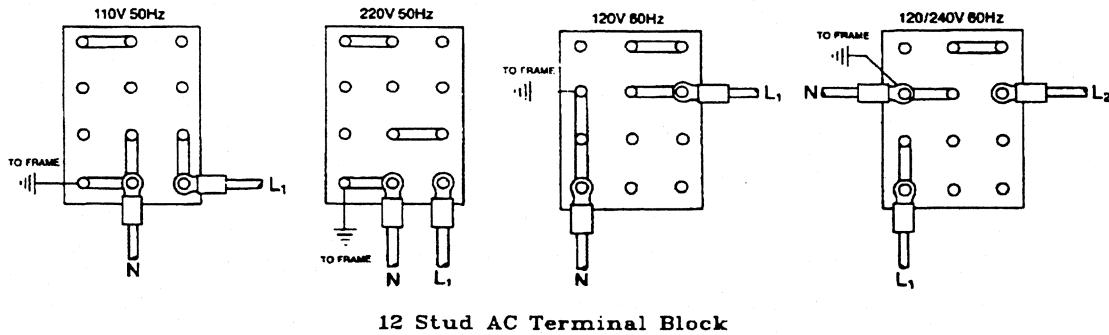

NOTE 1 - The frame ground wire must be moved when changing from 110 volts 50 hertz to 110/220 volts 50 hertz. For making connections to the AC terminal block, use terminal ends for #10 studs that will accept #6 or #8 multi-strand wire.

BT GENERATOR 6 TERMINAL BLOCK AC VOLTAGE CONNECTIONS

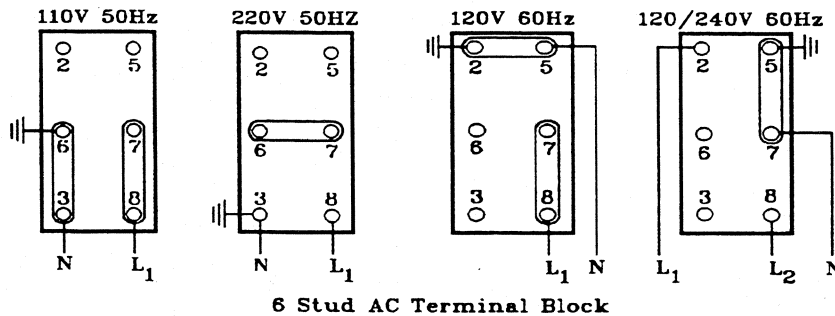

NOTE 1 - The frame ground wire must be moved when changing from 110 volts 50 hertz to 110/220 volts 50 hertz. For making connections to the AC terminal block, use terminal ends for 1/4 inch studs that will accept #1 or #0 multi-strand wire.

Generator Frequency Change

These adjustments should be made with no AC equipment being operated by the generator.

8.5 BTG models (12 stud AC terminal block).

1. Frequency is a direct result of engine/generator speed: 1800 rpm = 60 hertz; 1500 rpm = 50 hertz.
2. To change generator frequency follow the steps below.

- A. Connect the AC output leads to the AC terminal block, following the illustrations on the preceding page.
- B. Adjust the engine's speed to obtain the frequency corresponding to the voltage selected.
- C. Adjust the no-load voltage if it is needed by the compound transformer.
- D. Load the generator to the new amperage rating and reposition the loaded voltage tap to position X, Y, or Z as needed to maintain acceptable voltage output at full rated amperage output.

NOTE: Volts x amperage = kilowatts.

12.5 BTG and 15.0 BTG (6 stud AC terminal block).

- A. Arrange the AC out leads to the AC terminal block following the illustrations for the 6 stud AC terminal block.
- B. At the voltage/hertz bar, position the blue/white striped lead on the appropriate hertz connection (A) for 60 hertz and (B) for 50 hertz.
- C. Start the engine and adjust the engine speed for the correct no-load hertz (60 hertz: 61.5 - 62.0 hertz and 50 hertz: 51.5 - 52.0 hertz).
- D. Check the no-load voltage output and adjust it by the compound transformer.
- E. Load the generator to the amperage rating for the voltage/hertz being produced. Reposition, if needed, the double leads (red/white and red/yellow) to positions X, Y, or Z to maintain acceptable output voltage at full rated amperage output.

NOTE: When these connections are made, you may find it necessary to readjust the no-load output voltage with the compound transformer.

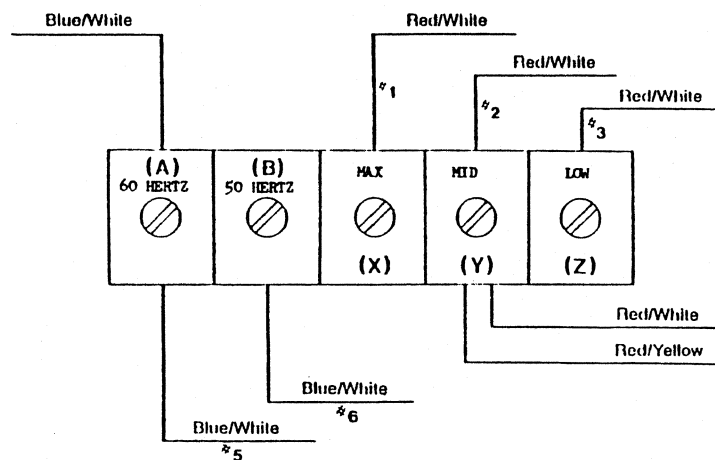

Voltage/Hertz Connection Bar

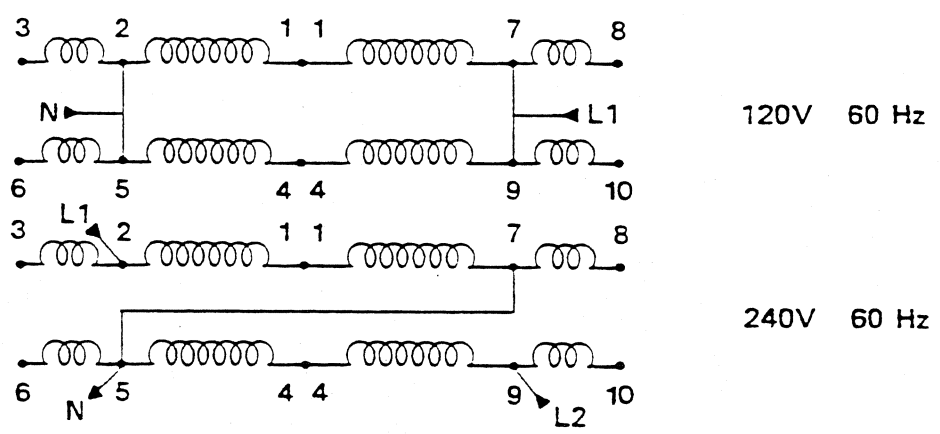
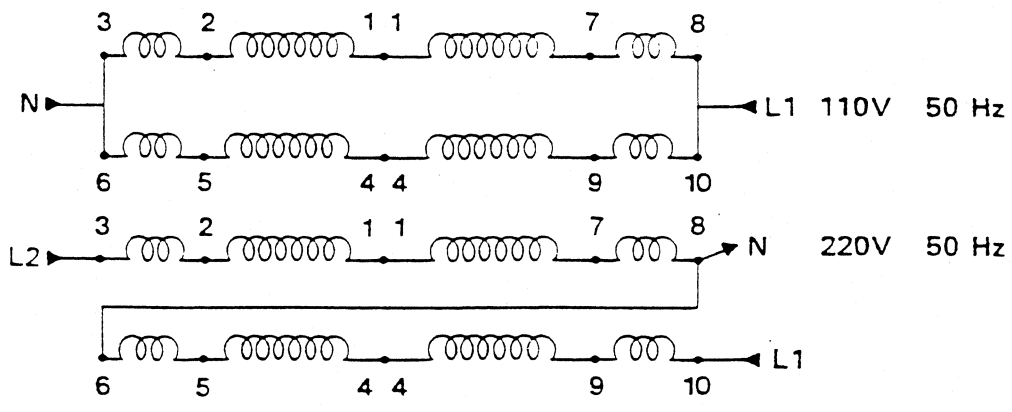

Winding connection to obtain the voltage and related frequency.

12 stud AC terminal block
8.5 BTG

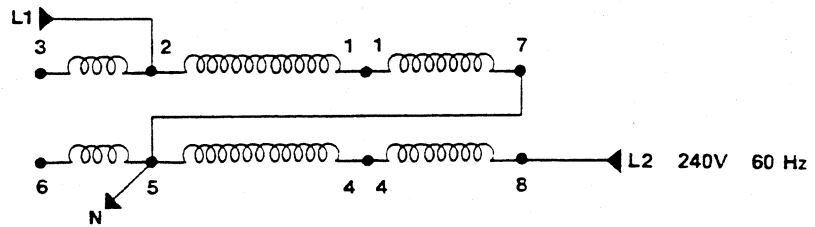
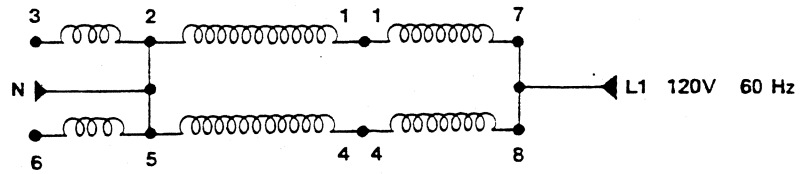
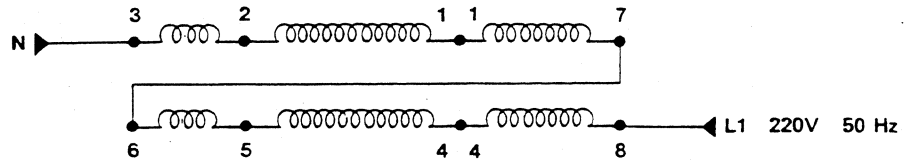
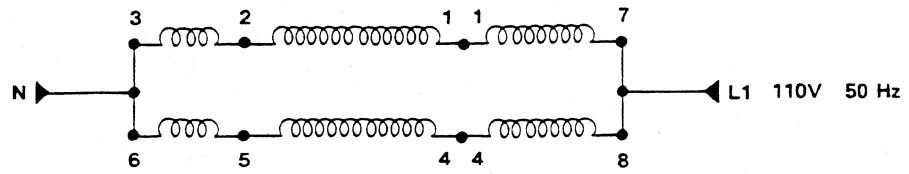

Winding connection to obtain the voltage and related frequency.

6 stud AC terminal block
12.5 - 15.0 BTG

NOTES