

COMPLIMENTARY COPY

Not for Sale  
Please insert in your  
Westerbeke Service Manual

# OPERATOR'S MANUAL

WESTERBEKE

7.0 KW BCG & 7.0 KW BCGA

MARINE GASOLINE

GENERATOR SET

Publication #038310

Edition One

June 1989



# OPERATOR'S MANUAL

WESTERBEKE

7.0 KW BCG & 7.0 KW BCGA

MARINE GASOLINE

GENERATOR SET

Publication #038310

Edition One

June 1989



## SAFETY PRECAUTIONS

The following symbols appear in this manual to call attention to and emphasize conditions potentially dangerous to the operator.

### WARNING

The above symbol is used in the manual to warn of possible serious personal injury or loss of life.

### CAUTION

The above symbol is used in the manual to caution personnel of possible damage to equipment.

Read the manual carefully and thoroughly before attempting to operate the equipment. Know when dangerous conditions can exist and take necessary precautions to protect personnel and equipment.

Fuels, exhaust gases, batteries, electrical equipment, and moving and hot parts are potential hazards that could result in serious personal injury or death. Follow recommended procedures carefully.

Always operate bilge blowers for at least five minutes before starting a gasoline-fueled engine; ensure no gasoline fumes are present before starting.

#### ● Prevent Electric Shock

Shut off electric power before accessing electrical equipment.

Use insulated mats whenever working on electrical equipment.

Make sure your clothing is dry, not damp (particularly shoes), and keep your skin surfaces dry when handling electrical equipment.

Remove wristwatch and jewelry when working on electrical equipment.

Do not connect utility shore power to vessel's AC circuits, except through a ship-to-shore double-throw transfer switch. Damage to vessel's AC generator may result if this is not done.

Be extremely careful when working on electrical components. High voltage can cause injury or death.

#### ● Exhaust Gases Are Toxic

Ensure that the exhaust system is adequate to expel gases discharged from the engine. Check exhaust system regularly for leaks and make sure the exhaust manifolds are securely attached and no warping exists.

Be sure the unit and its surroundings are well-ventilated.

#### ● Use Extreme Care When Handling Engine Fuel (A constant danger of explosion or fire exists)

Do not fill fuel tank(s) while the engine is running.

Do not smoke or use an open flame near the engine or the fuel tank.

#### ● Do Not Alter or Modify the Fuel System

Be sure all fuel supplies have a positive shut-off valve.

Be certain fuel line fittings are adequately tightened and free of leaks.

Make sure a fire extinguisher is installed nearby and is properly maintained. Be familiar with its proper use. Extinguishers rated ABC by the NFPA are appropriate for all applications encountered in this environment.

#### ● Use Extreme Care When Servicing Batteries

Wear rubber gloves, a rubber apron, and eye protection when servicing batteries.

Lead acid batteries emit hydrogen, a highly-explosive gas, which can be ignited by electrical arcing or by a lighted cigarette, cigar, or pipe. Do not smoke or allow an open flame near the battery being serviced. Shut off all electrical equipment in the vicinity to prevent electrical arcing during servicing.

#### ● Avoid Moving Parts

Do not service the unit while the unit is running; if a situation arises in which it is absolutely necessary to make operating adjustments, use extreme care to avoid moving parts and hot exhaust system components.

Do not wear loose clothing or jewelry when servicing equipment; avoid wearing loose jackets, shirts or sleeves, rings, necklaces, or bracelets that might be caught in moving parts.

Make sure all attaching hardware is properly tightened. Keep protective shields and guards in their respective place at all times.

Do not check fluid levels or the drive-belt's tension while the unit is operating.

Do not work on the equipment when mentally or physically incapacitated by fatigue.

**IMPORTANT**

**PRODUCT SOFTWARE DISCLAIMER**

Product software of all kinds, such as brochures, drawings, technical data, operator's and workshop manuals, parts lists and parts price lists, and other information, instructions and specifications provided from sources other than Westerbeke, is not within Westerbeke's control and, accordingly, is provided to Westerbeke customers only as a courtesy and service. **Westerbeke cannot be responsible for the content of such software, makes no warranties or representations with respect thereto, including the accuracy, timeliness or completeness thereof, and will in no event be liable for any type of damages or injury incurred in connection with, or arising out of, the furnishing or use of such software.**

For example, components and subassemblies incorporated in Westerbeke's products and supplied by others (such as engine blocks, fuel systems and components, transmissions, electrical components, pumps and other products) are generally supported by their manufacturers with their own software, and Westerbeke must depend on such software for the design of Westerbeke's own product software. Such software may be outdated and no longer accurate. Routine changes made by Westerbeke's suppliers, of which Westerbeke rarely has notice in advance, are frequently not reflected in the supplier's software until after such changes take place.

Westerbeke customers should also keep in mind the time span between printings of Westerbeke product software, and the unavoidable existence of earlier, non-current Westerbeke software editions in the field. Additionally, most Westerbeke products include customer-requested special features that frequently do not include complete documentation.

In summation, product software provided with Westerbeke products, whether from Westerbeke or other suppliers, must not and cannot be relied upon exclusively as the definitive authority on the respective product. It not only makes good sense but is imperative that appropriate representatives of Westerbeke or the supplier in question be consulted to determine the accuracy and currency of the product software being consulted by the customer.

**FOREWORD**

Thank you for selecting a Westerbeke marine product for your use. We at Westerbeke are pleased to have you as a customer.

Read this manual carefully and observe all safety precautions included throughout. Operating procedures, periodic preventive maintenance procedures, installation checks, system descriptions and minor adjustment procedures are included herein so you can operate your equipment safely and properly, maintain the equipment at a high level of efficiency, and expect dependable performance and long service life in return.

Should your unit require special attention, contact your Westerbeke dealer for assistance. The Westerbeke Service Organization is trained to provide the support necessary to ensure long-term dependable performance.

If, within 60 days of submitting the Warranty Registration Form for your unit, you have not received a Customer Identification Card (see below) registering your warranty, please contact the factory in writing with Model information, including the unit's serial number and commission date.

<b>from:</b>	WESTERBEKE CORPORATION AVON INDUSTRIAL PARK AVON, MA 02322
<b>Mail To:</b>	<div style="border: 2px solid black; border-radius: 15px; padding: 10px;"><div style="display: flex; align-items: center;"><span style="margin-left: 10px;"><b>WESTERBEKE</b></span></div><div style="font-size: 8px; margin-top: 2px;"><small>AVON INDUSTRIAL PARK, AVON, MA 02322 • TEL: (508) 520-7700 TEL#: 52-4444 • FAX: (508) 520-1503 • CABLE: WESTCOR</small></div><p><b>CUSTOMER IDENTIFICATION</b></p><p>Adam Smith 85 Maple Street Alden, IN 12234</p><p>Model BCG 7.0 KW      Ser. # 1234C986</p><p>Expires 11/15/89</p></div>

**TABLE OF CONTENTS**

Section .....	Page
GENERAL .....	5
7.0 KW BCG & BCGA GENERAL SPECIFICATIONS .....	8
7.0 KW BCG & BCGA SYSTEM SPECIFICATIONS.....	9
INSTALLATION CHECKS.....	12
DESCRIPTION OF ENGINE CONTROL PANEL.....	25
PREPARATIONS FOR STARTING .....	27
STARTING PROCEDURE.....	28
STOPPING PROCEDURE.....	31
CARBURETOR AND FUEL SYSTEM.....	32
ELECTRICAL SYSTEM.....	35
DC CONTROL CIRCUIT WIRING DIAGRAM # 38028 .....	38 & 39
OPTIONAL REMOTE START PANEL WIRING DIAGRAM # 38024 .....	40
OPTIONAL REMOTE INSTRUMENT PANEL WIRING DIAGRAM # 38025 .....	41
COOLING SYSTEM.....	42
LUBRICATION SYSTEM .....	48
BC GENERATOR.....	51
BCA GENERATOR .....	52
GENERAL INFORMATION AND CARE OF THE GENERATOR .....	57
ENGINE TROUBLESHOOTING .....	59
MAINTENANCE & ADJUSTMENTS.....	63

**TABLE OF CONTENTS  
(CONTINUED)**

LAY-UP & RECOMMISSIONING .....	71
SPARE PARTS LIST .....	74
TABLE OF STANDARD HARDWARE TIGHTENING TORQUES .....	75
TABLE OF TIGHTENING TORQUES .....	76
INDEX .....	77

[www.torresen.com](http://www.torresen.com)

## GENERAL

### Introduction

This manual contains the equipment operating procedures as well as additional information needed to help the operator keep the marine equipment in proper working order. Study and follow the instructions carefully. A planned maintenance program is included in this manual; adhering to the program will result in better equipment performance and longer equipment life. Proper diagnosis of a problem is the most important step to satisfactory repair; therefore, a troubleshooting table is included.

### Understanding the Gasoline Engine-Driven Generator

The gasoline engine driving an AC generator is in many ways similar to a gasoline automobile engine. The cylinders are vertical in-line, and the engine's cylinder head has an overhead camshaft which is belt-driven. The engine utilizes conventional points and a condenser-type distributor which is horizontally mounted and camshaft-driven. The engine incorporates a pressure-type lubrication system, and a fresh water-cooled engine block which is thermostatically-controlled. To a large degree, the generator's engine requires the same preventive maintenance that is required of a gasoline automobile engine. The most important factors to the generator's longevity are proper ventilation, maintenance of the fuel system, ignition system, cooling system, lubrication system and the AC alternator.

### Ordering Parts

Whenever replacement parts are needed, always provide the generator model number designation (i.e. 7.0 KW BCG), engine serial number, and generator serial number as they appear on the data plates located on the generator end and on the exhaust manifold. You must provide us with this information so we may properly identify your generator set. In addition, include a complete part description and part number for each part needed (see the separately furnished Parts List). Also, be sure to insist upon Westerbeke factory packaged parts, because "will fit" or generic parts are frequently **not** made to the same specifications as original equipment.

Note that component locations in the manual are referenced from the front of the engine which is the pulley/drive belt end. (The flywheel/generator end is the rear end.) Left and right sides are determined by the engine; imagine straddling the engine and facing in the same direction as the front of the engine: the left side is at your left, the right side at your right.

Westerbeke generator sets are thoroughly checked and given a final run under various load conditions before leaving the factory. Test running the generator ensures dependable operation, long service, and a satisfied owner.

Care at the factory during assembly and thorough testing have resulted in a Westerbeke gasoline engine-driven generator capable of many thousands of hours of dependable service. However, what the manufacturer cannot always control is the manner or location the generator is installed in the vessel or the manner in which the unit is operated and serviced in the field. That part is up to the buyer/owner-operator.



7.0 KW BCG & BCGA Marine Gasoline Generator

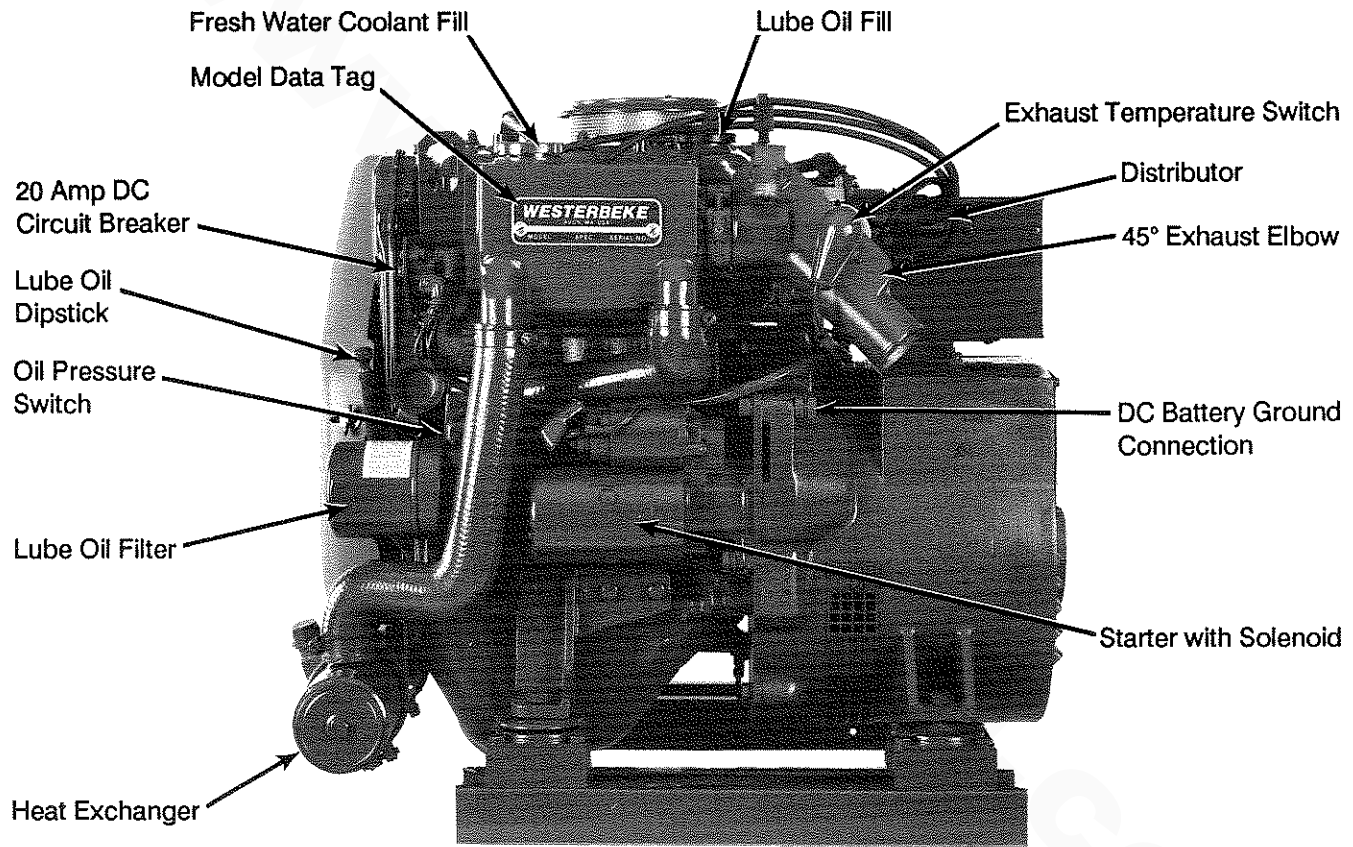

7.0 KW BCG & BCGA Marine Gasoline Generator

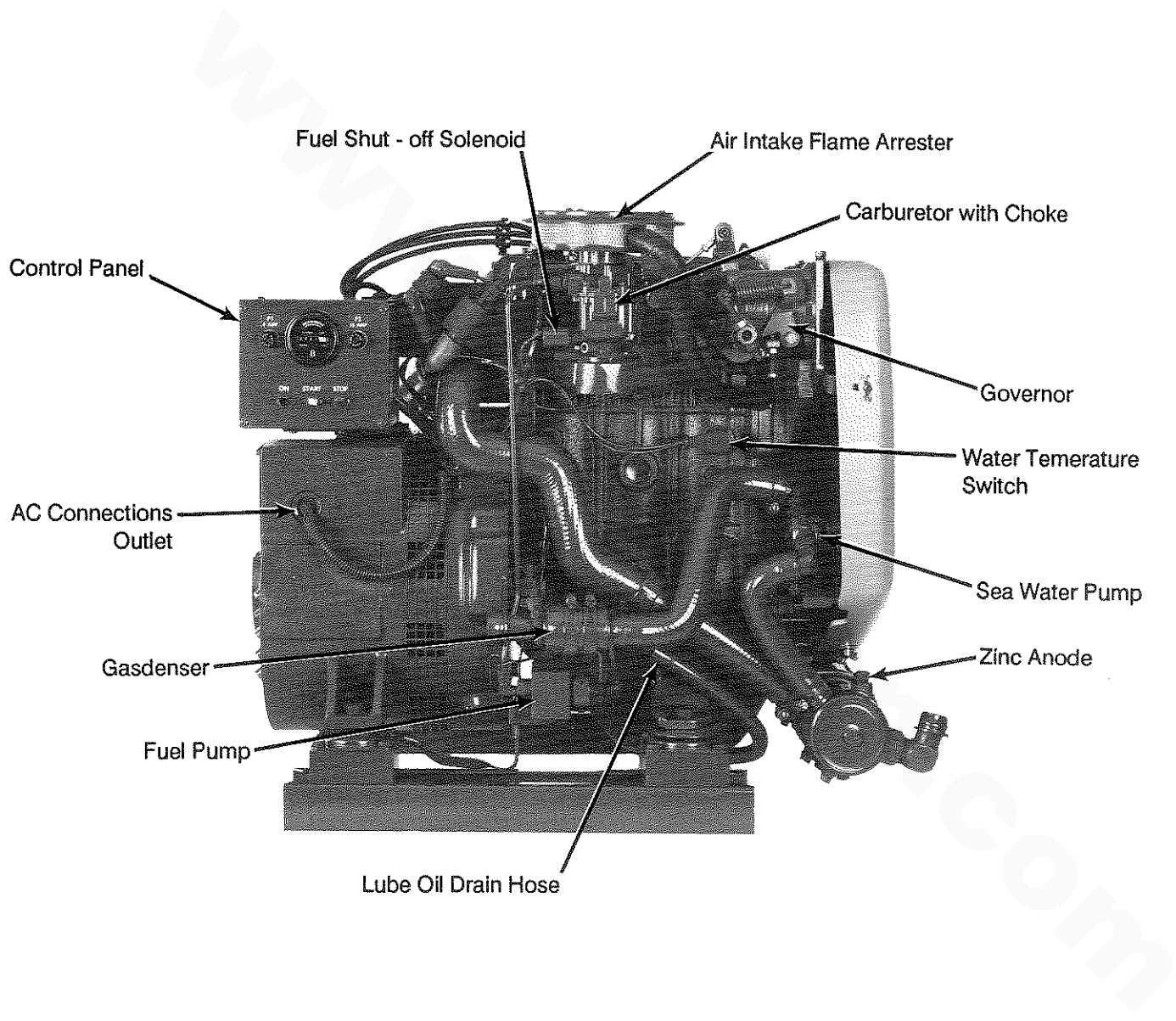

Fuel Shut - off Solenoid

Air Intake Flame Arrester

Carburetor with Choke

Control Panel

Governor

AC Connections  
Outlet

Water Temperature  
Switch

Gasdenser

Sea Water Pump

Fuel Pump

Zinc Anode

Lube Oil Drain Hose

**7.0 KW BCG & BCGA MARINE GASOLINE GENERATOR SET  
GENERAL SPECIFICATIONS**

Engine Type	Gasoline, four-cycle, three-cylinder, fresh water-cooled Vertical, in-line overhead valve mechanism (8 bhp at 1800 rpm, maximum).
Governor	Hoof, flyball type, 5% speed regulation.
Combustion Chamber	Multi-sphere type.
Bore & Stroke	2.62 x 3.19 inches (66.6 x 81 mm)
Piston Displacement	51.6 cubic inches (.846 liter)
Firing Order	1-2-3
Direction of Rotation	Clockwise, when viewed from the front.
Maximum Torque (at 1800 rpm)	13.5 lbf-ft
Compression Ratio	9.5:1
Compression Pressure (Limit of difference between cylinders)	213.3 psi (15.0 kg/cm <sup>2</sup> ) at 400 rpm (28 psi [2.0 kg/cm <sup>2</sup> ])
Valve Timing	Intake Opens 28° BTDC Intake Closes 62° ABDC  Exhaust Opens 62° BBDC Exhaust Closes 28° ATDC
Valve Seat Angle	Intake 45° Exhaust 45°
Valve Clearance (engine warm)	Intake 0.0098 inches (0.25 mm) Exhaust 0.0118 inches (0.30 mm)
Engine Speed	1800 rpm 60 hertz. 1500 rpm 50 hertz.
Dimensions	Length: 26.50 inches (673.1 mm) Width: 18.34 inches (465.8 mm) Height: 23.44 inches (595.4mm)
Dry Weight	Approx. 309 lbs (140.1 kgs)
Fuel Consumption	0.8 U.S. gph (3.02 lph) at full rated output (approximate).
Inclination	Continuous 14° Temporary 20° (not to exceed 20 min.)

7.0 KW BCG & BCGA SYSTEM SPECIFICATIONS

**INTAKE SYSTEM**

Carburetor (STD type) Manual with butterfly shaped valve, single barrel with U.S.C.G. approved flame arrester.

**IGNITION SYSTEM**

General Battery ignition, 12-volts (negative ground), distributor with points, ignition coil and spark plugs.

Distributor Conventional, contact-point type.

Spark Plug Thread Size 14 x 1.25 mm pitch (0.55 x 0.05 in.)

Spark Plug Type Westerbeke part number 33805  
(Always identify the generator model when ordering parts.)

**FUEL SYSTEM**

General Conventional carburetor type with fuel pump.

Fuel Regular or unleaded gasoline with an octane rating of 89 or higher.

Fuel Pump 12-volt DC; lift capacity 5 ft (1.5 m)

Fuel Screens (on engine) Reusable screen type (located at inlet to carburetor).

Air cleaner Metal screen type - cleanable.

Air Flow (engine combustion) 26.8 cfm (0.758 cmm) at 1800 rpm.

**COOLING SYSTEM**

General Fresh water-cooled block, thermostatically-controlled with a heat exchanger.

Operating Temperature 130 - 150°F (55 - 66°C )

Fresh Water Pump Centrifugal type, belt-driven, 1.13:1 to crankshaft.

Raw Water Pump Positive displacement, rubber impeller, belt-driven.

### 7.0 KW BCG & BCGA SYSTEM SPECIFICATIONS

Raw Water Flow, at 1800 rpm (measured before discharging into exhaust elbow)	3.75 - 4.0 U.S. gpm (14.19 - 15.14 lpm)
System Capacity (fresh water)	4.2 U.S. qts (3.9 liters)

### LUBRICATION SYSTEM

General	Fully - Force fed type by Trochoid pump, crankshaft-driven.
Oil Filter	Full flow, paper element, spin-on type. P.N. 036918
Sump Capacity (not including filter)	3.0 qts (2.8 liters)
Operating Oil Pressure (engine hot)	50 - 70 psi (3.5 - 4.9 kg/cm <sup>2</sup> )
Oil Grade	API specification of SE, SF or SG.

### ELECTRICAL SYSTEM

Starting Battery	12-volt, 24 A-H, (-) negative ground (recommended) (28 A-H in cold areas).
Battery Capacity	24 - 28 (ampere-hours)
DC Battery Charger	Integral controller 13-volt, 10 amp (located in the AC alternator).
Starter	12-volt, 1.2 KW, Magneto engaging type.
DC No-Load Current	90 amp (max.) at 11.5 volts.
DC Cranking Current	100 - 125 amps (engine cold).

**7.0 KW BCG & BCGA SYSTEM SPECIFICATIONS**

**AC GENERATOR**

**General** Brushless, four-pole, revolving field.  
 Self exciting. Capacitor saturated field excitation.  
 Pre-lubricated, single-bearing design.  
 Reconnectable 120 volts or 120/240 volts,  
 single-phase.

**Voltage** 120 or 120/240 volts - 60 hertz  
 220 volts - 50 hertz.  
 Voltage regulation: ±5% no-load to  
 full-load.  
 Frequency regulation: ± 3 hertz (5%)  
 no-load to full-load.

NOTE: BCGA models are 60 hertz only. This model cannot be converted to 50 hertz.

**Rating (volts AC)**

60 Hertz (1800 rpm)	120 volts	58 amps
	120/240 volts	58/29 amps
50 Hertz (1500 rpm)	220 volts	23 amps

**AC Circuit Breaker** To be rated at 120% of the generator's rated  
 amperage and voltage output.

**Generator Cooling**  
**Air Requirements, (60 hertz),**  
**at 1800 rpm** 250 cfm (7.0 cmm)

NOTE: Increase air supply 15% for 50 hertz operation (1500 rpm).

**Engine Combustion Air**  
**Requirements, (60 hertz),**  
**at 1800 rpm** 26.8 cfm (0.758 cmm)

**TUNE-UP SPECIFICATIONS**

**Spark Plug Gap** 0.028 - 0.031 inches (0.70 - 0.80 mm)

**Contact Point Clearance** 0.017 - 0.018 inches (0.4 - 0.5 mm)

**Timing** 10° ± .5° BTDC at 1800 rpm

**Dwell Angle** 58 - 66°

## INSTALLATION CHECKS

### General

Since the crafts in which Westerbeke generators are installed vary in design, installation procedures will vary according to your craft's specific design. The intent of this section is not to advise boatyards or installers on procedures already well-developed and well-understood. However, the owner/operator must realize there are details of the installation which require periodic checks to ensure the best operating conditions for the equipment and safe operating conditions for the personnel on board. Proper location and installation of the gasoline generator in the vessel are of prime importance.

Factors in the installation that *must* be considered are ventilation, to aid in cooling the generator end; to provide air for engine combustion and to remove heat produced by the engine while operating; the exhaust system, to properly discharge raw cooling water (sea water); to quiet the exhaust and to expel exhaust gas; the cooling water supply; the electrical connections, both AC and DC, and a fuel system that will provide an unrestricted fuel supply and properly filtered fuel to the fuel pump on the engine.

### CAUTION

For safety reasons, the generator's engine is **not** filled with lubricating oil for shipment. Before leaving the factory, however, each generator set is thoroughly tested with oil in its engine. This testing, among other things, provides all internal parts with a coating of oil. This oil acts as a preservative, providing reliable protection against corrosion for at least one year if the generator is properly stored.

### Inspection of Equipment

The generator is shipped from the factory securely mounted and properly crated. Accessory equipment is shipped in a separate small box, usually packed within the generator's crate.

Before accepting shipment of the generator set from the transportation company, the crate should be opened and the contents inspected for concealed damage. If either visible or concealed damage is noted, you should require the delivery agent sign "Received in damaged condition" on the proper delivery receipt. Also, check the contents of the shipment against the packing list and make sure that the proper notation is made if any discrepancies exist. These noted discrepancies are your protection against loss or damage. Claims concerning loss or damage *must* be made to the carrier, not to Westerbeke Corporation.

## Rigging and Lifting

The generator is fitted with lifting eyes. Rope or chain slings capable of supporting the generator's weight should be attached to the eyes and the generator lifted by means of tackle attached to these slings. The lifting eyes have been designed to carry the full weight of the generator; therefore, auxiliary slings are not required or desired.

### CAUTION

Slings must **not** be so short as to place significant stress on the generator's lifting eyes. Strain placed on the generator's lifting eyes by the lifting sling must **not** be in excess of 10° from the vertical plain.

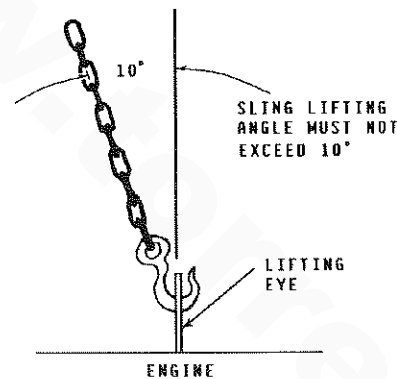

The general rule in moving generators is to see that all equipment used is amply strong and firmly fixed in place. Move the engine a little at a time and see that it is firmly supported. Eliminate the possibility of accidents by avoiding haste. **Do not** lift the generator by its crankshaft pulley. In certain situations it may be necessary to lift the engine in positions other than the horizontal position. Certain situations exist by which the engine must be lowered endwise through a small hatchway which cannot be made larger. Under these conditions, if the opening of the hatchway is extremely small, it is possible to reduce, to some extent, the outside dimensions of the generator by removing external components such as the cooling system's piping, the heat exchanger, certain filters, the mounting rails and other obstructive equipment. This accessory equipment should be removed by a competent mechanic and special care should be taken to avoid damage to any exposed parts. In addition, be careful not to allow dirt and foreign matter to enter any opening created by the removal of engine components. Removed parts/components should be returned to their respective position as soon as the generator has cleared the obstruction and is ready to be positioned on its mounting platform. Be sure to use new gaskets where and when needed.

In case it becomes necessary to hoist the generator front-end upwards or generator-end upwards, the attachment of lifting slings must be done *carefully* to avoid the possibility of damaging the parts on which the weight of the slings may bear. Special rigging work is best done by someone experienced and competent in handling heavy machinery.



### Generator Mounting - Location

The complete generator unit is mounted on lightweight rails by means of four flexible isolator mounts that help prevent the transfer of vibration from the generator to the rails. Each generator mounting rail has several 1/2 inch bolt holes so bolts can be employed to properly secure the generator to its mounting platform. These holes are on 13.5 or 14.5 inch mounting centers. Consult the sales brochure for exact mounting specifications.

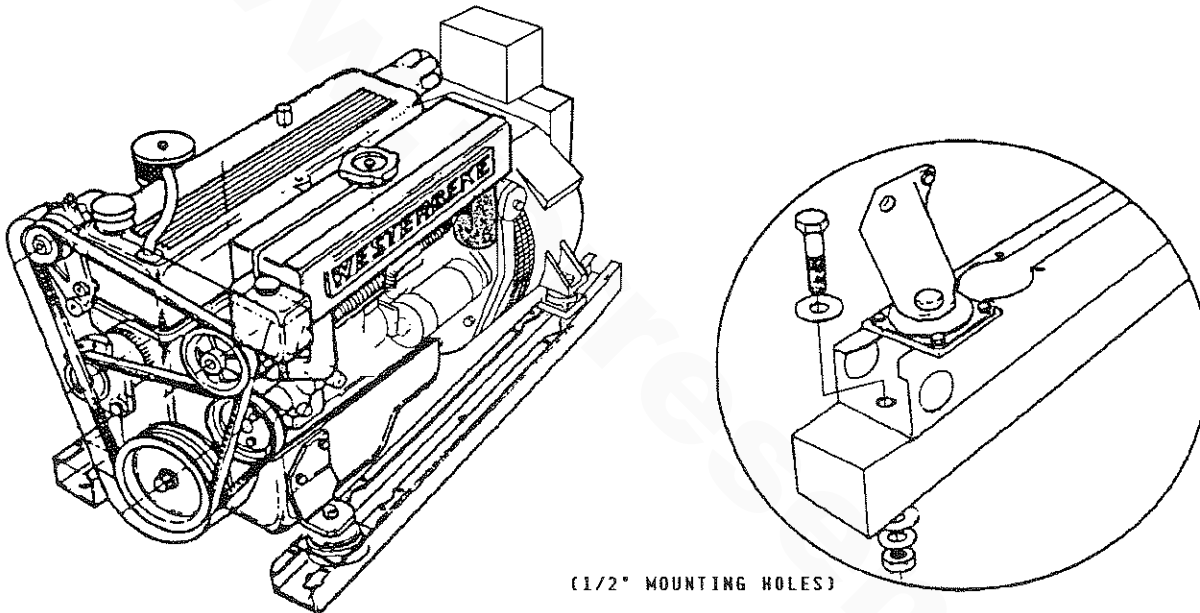

The mounting location must be dry, above low-lying vapor areas, and in an area where bilge water and water from above cannot splash or drip on the generator or drive engine. The drive engine and generator must be accessible for minor servicing and repairs. Access for major repairs should be given consideration as well. The generator set must be properly ventilated to provide fresh cooling air for the generator end, for engine combustion needs, and to remove heat produced by the engine while operating. The generator set needs fresh cool air in whatever location in the vessel it is installed. Hot generator discharge air must be removed from the generator area. The platform on which the generator and its mounting rails are located must be strong enough to support the generator during all angles of vessel operation.

Exhaust System

**WARNING**

**Carbon monoxide gas is deadly!** Carbon monoxide is a dangerous gas that can cause unconsciousness and is potentially lethal. Some of the symptoms or signs of carbon monoxide inhalation or poisoning are listed below.

- o Dizziness
- o Intense Headache
- o Weakness and Sleepiness
- o Vomiting
- o Muscular Twitching
- o Throbbing in Temples

The generator should have its own separate exhaust installed so that the entry of raw water into the engine's exhaust manifold and cylinders is prevented while the engine is not running, or while the vessel is under sail or power in which case the vessel may experience heeling, backing down from following seas, or any other conditions. Special attention must be taken to make certain the exhaust system is secure, tight and free of leaks.

The raw water supply through-hull sea cock fittings must be of the flush-hull type. High-speed scoop types or weedless scoop types must not be used, as they tend to encourage siphoning.

When a water lift type exhaust system is used, the exhaust muffler should be mounted as close to the engine as practical. The exhaust discharge should always drop downward into the exhaust muffler. Loops in the exhaust hose between the water-injected exhaust elbow and the water lift muffler should be avoided, as these will trap and hold water.

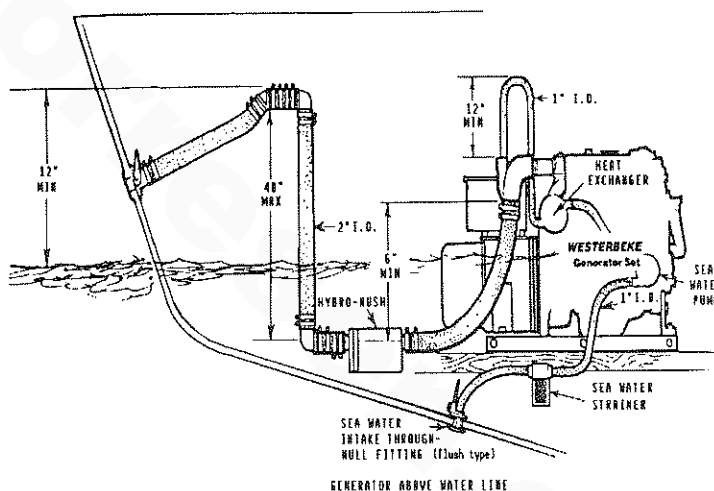

GENERATOR ABOVE WATER LINE

For installations where the exhaust manifold/water-injected exhaust elbow is close to or below the vessel's water line, provisions must be made to install a siphon-break or a vent in the raw water supply hose to the water-injected exhaust elbow. This stops the flow of raw water that runs through the raw water cooling system from filling the exhaust and engine cylinders when the engine is shut down. This raw water supply hose must be looped above the water line and the siphon-break or vent installed in the high point of the loop above the water line. This siphon-break or vent must always be above the water line during all angles of vessel operation to prevent siphoning. The vent, when used, must have its vent hose or tube routed so it can remain above the water line and empty of water when the engine is shut down. This allows air to enter through this vent to prevent siphoning.

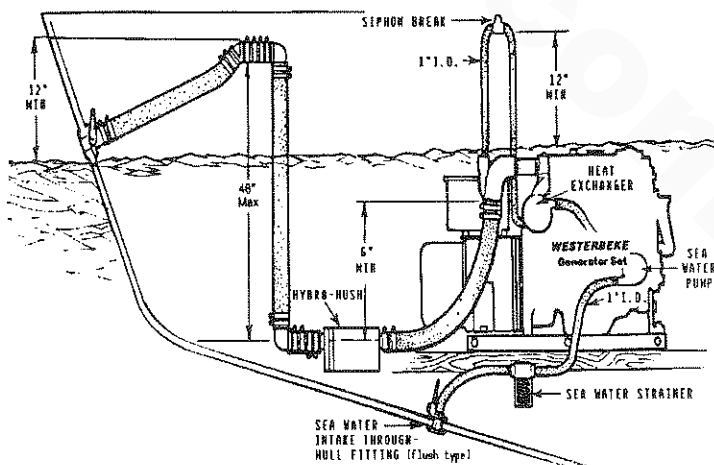

GENERATOR BELOW WATER LINE

Excessive back-pressure can be caused by a small diameter exhaust hose, a small muffler, sharp bends in the exhaust hose, improper fittings, water pockets, and a high volume of water in the exhaust system due to the length of the exhaust discharge hose. The use of elbows and fittings in the exhaust discharge hose's routing should be limited since these will create flow restrictions and contribute to exhaust back-pressure. The generator's exhaust system *must* be separate from any other engine's exhaust system. Dry portions of the exhaust system between the engine's exhaust manifold and the water injected exhaust elbow *must* be insulated to hold in the heat.

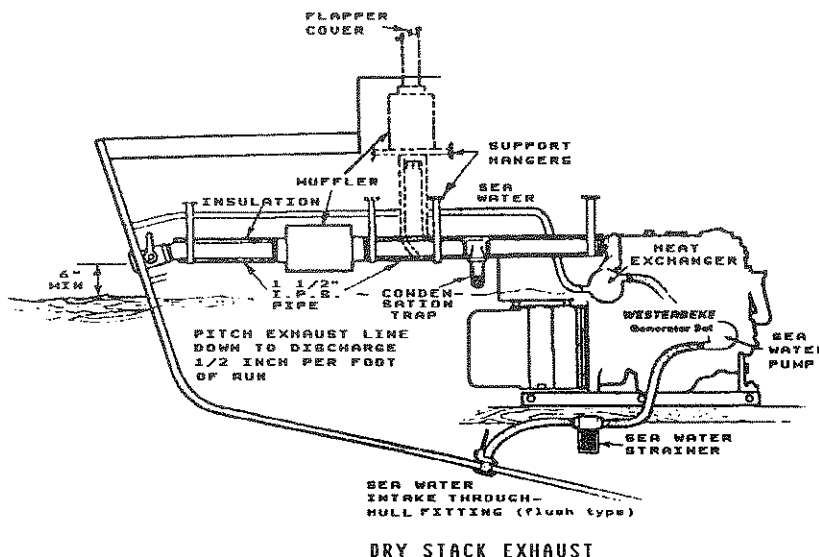

Dry stack-type exhaust systems (shown above) *must* be attached to the generator engine's exhaust manifold by means of a flexible connector pipe. This system *must* be properly supported and insulated to prevent water from entering into the engine's cylinders. Provisions *must* be made for discharging the engine's raw cooling water.

**Exhaust Back-Pressure**

The exhaust discharge hose *must* be of adequate size and minimal run to prevent excessive exhaust back-pressure. Exhaust back-pressure should be checked before a generator is put into service. (Refer to the illustration.) Excessive back-pressure will affect the engine's performance which affects generator AC power output.

To measure for back-pressure, use a mercury manometer, a pressure gauge, or a water column. A boatyard or marine mechanic should have a manometer or a pressure gauge. If the generator set does not have a tapped hole in its exhaust elbow, one *must* be drilled and tapped for a 1/8 inch NPT fitting in the dry area of the elbow.

Measure the engine's back-pressure at the exhaust elbow while the generator is under a full-load.

Refer to the pressure specifications listed on the following page.

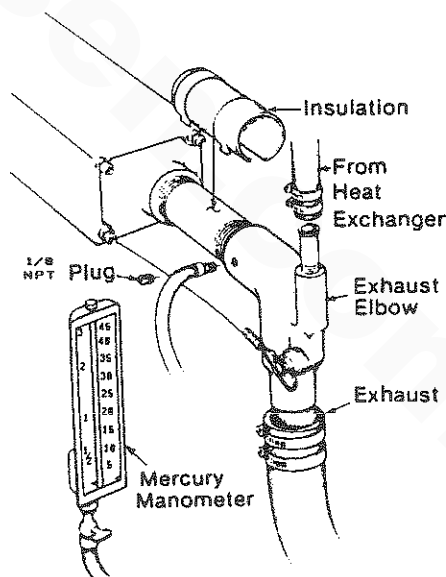

A water column can be made by taking a clear plastic tube and taping one end of the tube along a yardstick and fitting the other end of the tube with a 1/8 inch NPT (National Pipe Tap) pipe fitting.

Measure the engine's back-pressure at the exhaust elbow while the generator is under a full-load.

Dimension **A** cannot exceed 39 inches of water.

Back pressure, as measured by a gauge instrument, should **not** exceed the following specifications:

- 3 inches of mercury (0.104 kg/cm<sup>2</sup>)
- 39 inches of water in a water column  
(.099 kg/cm<sup>2</sup> at 4° C)
- 22 ounces psi
- 1 1/2 psi

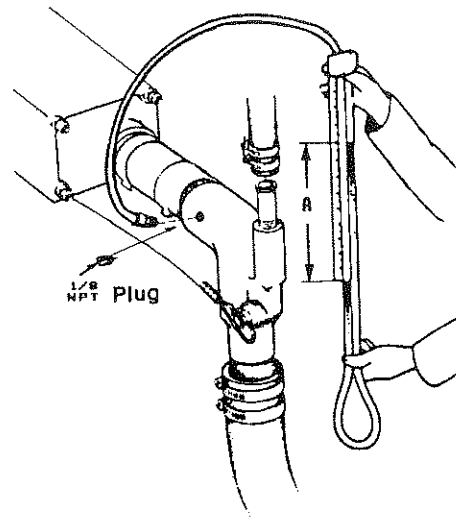

### Exhaust System Failures

When the engine's raw water is fed into an exhaust system so that the full stream of this water strikes a surface, erosion takes place. This erosion may cause premature failures. The proper design of either a water jacketed or water injected "wet" exhaust system to prevent this problem requires that the raw water inlet be positioned so that the entering stream of raw water does **not** directly strike a surface. In addition, the velocity of the entering raw water stream should be as low as possible, which can be achieved by having inlet fittings as big in diameter as possible.

The best protection against carbon monoxide poisoning is a daily inspection of the complete exhaust system. Check for leaks around manifolds, gaskets, and welds. Make sure exhaust lines are **not** heating surrounding areas excessively. If excessive heat is present, correct the situation immediately. If you notice a change in the sound or appearance of the exhaust system, shut down the unit immediately and have the system inspected and repaired at once by a qualified mechanic.

Make sure there are no unnecessary objects suspended from any portion of the exhaust lines. Exhaust risers installed off the exhaust manifold **should not exceed 8 lbs** in total weight when rigidly constructed. Excessive weight could cause deflection or distortion of the manifold resulting in damage and/or internal leaks. Inspect insulated portions of the exhaust system to ensure there is no deterioration of the insulation.

### CAUTION

Prolonged cranking intervals without the engine starting can result in filling the engine-mounted exhaust system with raw water coolant. This may happen because the raw water pump is pumping raw water through the raw water cooling system during cranking. This raw water can enter the engine's cylinders by way of the exhaust manifold once the exhaust system fills. Prevent this from happening by closing the raw water supply through-hull shut-off, drain the exhaust muffler, and correct the cause for the excessive engine cranking needed to obtain a start. Engine damage resulting from this type of raw water entry is **not** a warrantable issue; the owner/operator should keep this in mind.

### Exhaust Elbow Installation

The Westerbeke Corporation offers a 45° and 90° exhaust elbow as well as an exhaust riser you can install on your generator. Refer to the instructions below when installing the exhaust elbow purchased for your generator.

**NOTE:** Fabricated exhaust elbows or risers attached to the exhaust manifold **shall not exceed 8 lbs when unsupported.**

1. Coat only one side of the exhaust gasket with \*"High Tack" adhesive sealant. Place this coated surface against the exhaust manifold's exhaust port flange (the gasket should stick to the flange without falling off).
2. Place the clamp over the elbow's flange. Place your exhaust elbow against the exhaust manifold's flange so the exhaust manifold's flange rests snug against the exhaust elbow's flange with the gasket centered between the two. Now slip the exhaust clamp over both flanges.
3. A. Tighten the clamp just enough so the exhaust elbow can remain attached to the manifold and still be rotated.  
 B. The exhaust elbow discharge *must* be directed **downward** so the mixture of raw water and exhaust gases will flow/fall downward into the exhaust muffler which *must* be positioned below the exhaust elbow. There should be no loops or rises in the exhaust hose connected between the exhaust elbow and the muffler, as these would trap water and possibly allow water to flow back into the engine during starting or at shut down.
4. Adjust the elbow by rotating it until the desired alignment with the exhaust piping is acquired.
5. Carefully tighten the clamp between 2 to 3 lb-ft, or 24 to 35 lb-in, or 0.27 to 0.41 kg-m.

#### CAUTION

Approach the 3 lb-ft torque limit with caution. The clamp's threads will break if more than 3 lb-ft is applied to the clamp.

If a leak exists, correct it immediately.

\* Manufactured by Permatex Company, Brooklyn, N.Y.

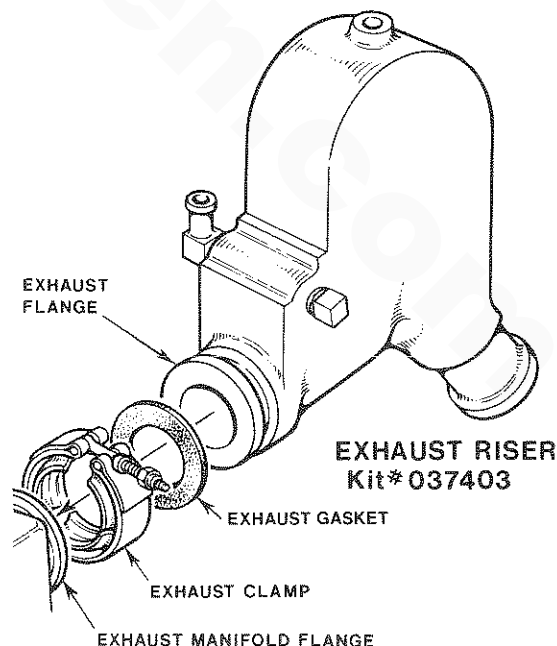
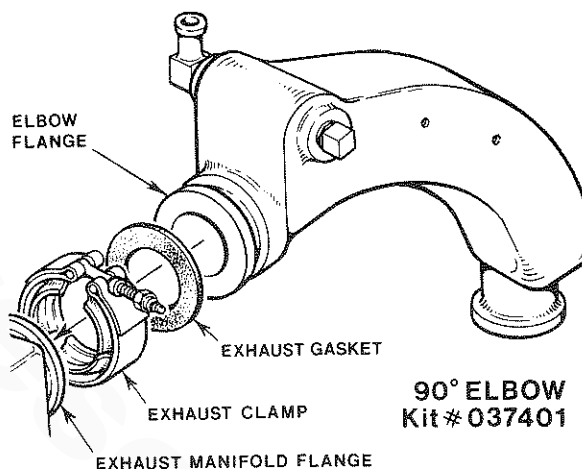
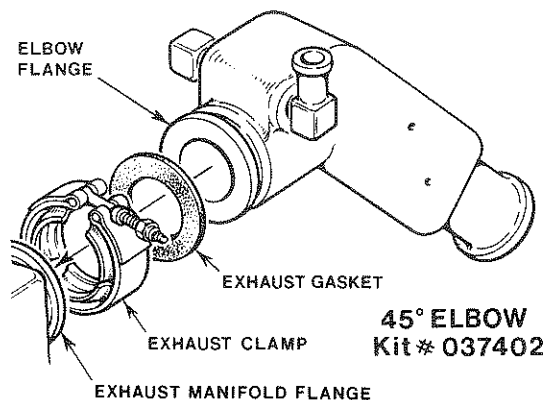

**Fuel System**

The generator *must* have its own fuel supply line; in other words, it *must* have its own fuel tank pickup tube and primary filter/water separator. Do not tee off another engine's fuel supply. Installations where the fuel tank(s) are at or above the generator, with the fuel supply lines to the engine's carburetor routed below the level of the fuel tank's top, *must* have a means of shutting off the fuel to the generator's engine when the engine is not running. This installation procedure helps guard against the possibility of gasoline siphoning through the supply line into the engine through the carburetor, should the carburetor float needle valve stick in the open position or not seat properly, or should the fuel line rupture between the engine and fuel tank.

This (anti-siphon) shut-off valve can be electrically-operated (with a manual override) to open when the generator's engine is started, and to close when the generator's engine is shut down. A manually-operated valve can also be installed and should be operational from the generator's start/stop panel or from the vessel's deck. Installations where the generator is located above the fuel tank(s), whereby the routing of the fuel supply line to the generator's carburetor remains above the top level of the fuel tank, do not require this (anti-siphon) shut-off valve. A manually-operated service shut-off valve should be located between the fuel pickup at the tank and the service shut-off valve located at the fuel connection to the generator.

The two illustrations that follow were taken from the Coast Guard publication *Fuel System Compliance Guideline*. These illustrations show basic fuel system layouts that incorporate anti-siphon protection.

All fuel lines should be routed and supported to prevent leaks from vibration and chafing. The line should be supported every 12 - 14 inches. Use as few connections as possible in the plumbing of these lines.

The fuel tank's vent should be located so that its discharge route cannot allow water to enter through to the fuel tank(s). Moisture must not be allowed to accumulate in the vent's line.

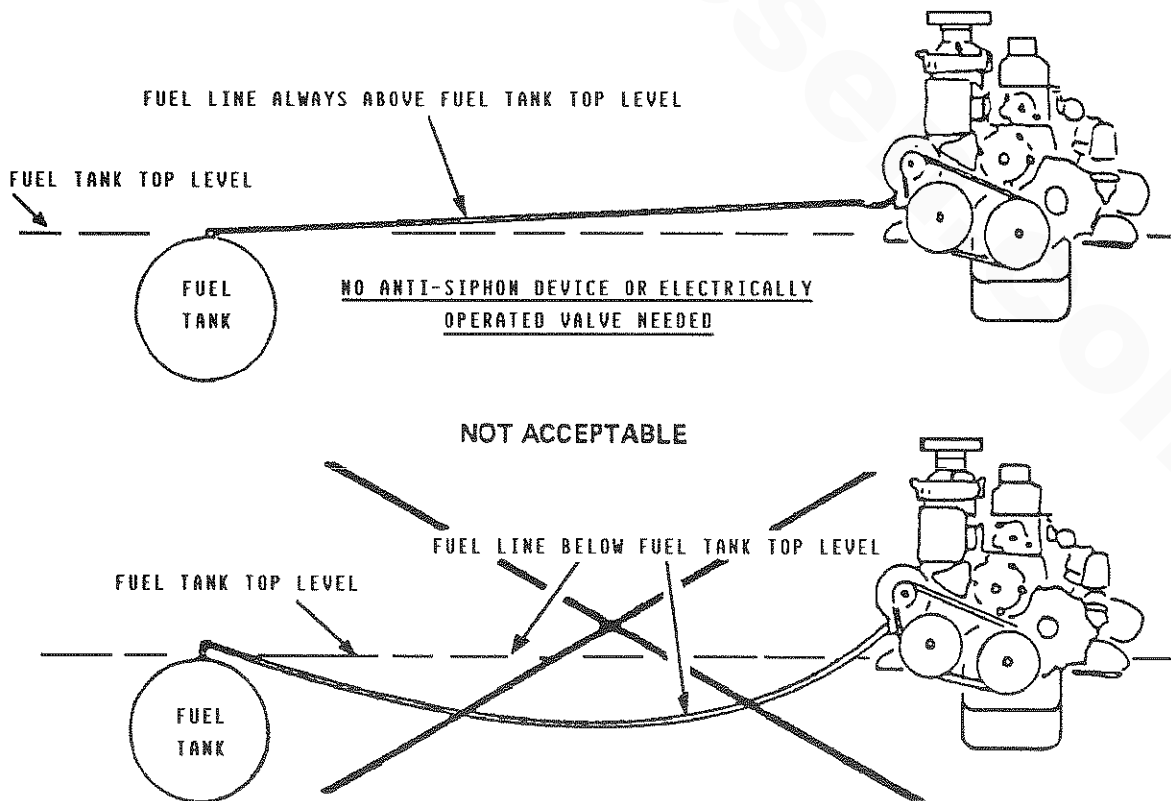

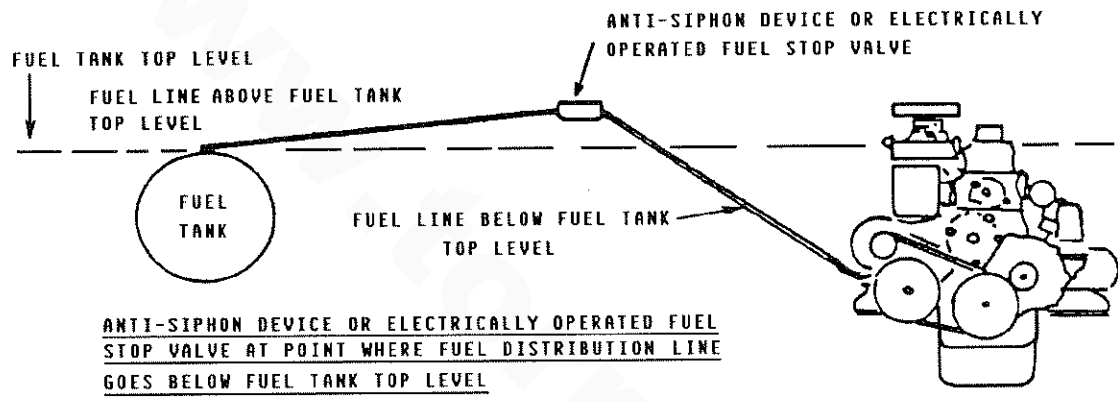
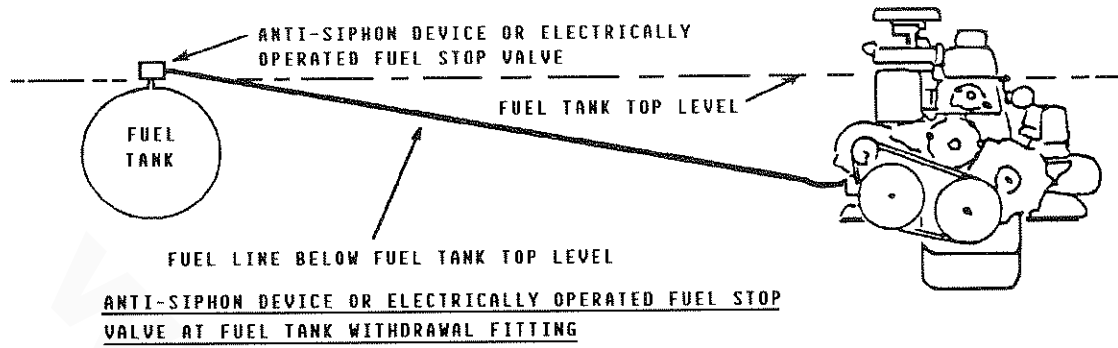

NOTE: The use of mechanical spring-type check valves instead of a solenoid shut-off valve is not recommended since these may tax the fuel pump's ability to draw fuel through a check valve. A check valve can trap debris under its seat which inhibits the valve's ability to close. In addition, if a check valve's cracking pressure is too high, this can contribute to vapor lock.

Should a mechanical type, spring-loaded check valve be used, it should be an adjustable type, such as a Weatherhead #43 x 6. This adjustable type valve should be adjusted to have a cracking pressure that will prevent siphoning when the generator is not operating but not so excessive as to prevent the fuel pump from drawing fuel through the valve.

The installer should install an approved fuel filter/water separator in the fuel supply between the fuel tank and the generator's engine to help remove contaminants in the fuel before the fuel reaches the engine-mounted fuel pump and carburetor. Such contaminants can cause the failure of these system components and such failures are not warrantable. Owner/operators are advised it is their responsibility to maintain filter/separators so that contaminants do not reach the engine's fuel system.

**WARNING**

Fuel leakage in or around the generator compartment is a potential cause of fire and/or explosion. Repair leaks promptly and make sure the compartment is properly ventilated.

### Oil Drain Hose

An oil sump drain hose is installed on the engine with the discharge end secured by a bracket at the front of the engine. Oil may be drained from this hose by removing the cap and the discharge end of the hose from the support bracket and lowering the hose into a container. The hose cap fitting is 1/4 inch NPT (National Pipe Tap) and can be extended or have a pump added, by the operator, for easier removal of the old oil, if desired.

### Connecting Pressure Sensing Devices to Oil Galleries

Oil pressure sensing devices, such as senders and switches, must **not** be connected to an engine's oil gallery with the use of extended nipples or tees. The reason is simply that continued engine vibration causes fatigue of the fittings used to make such a connection. If these fittings fail, the engine loses its oil pressure and quickly seizes.

When additional sensing devices such as switches or sensors need to be installed that function on engine oil pressure, these devices *must* be bulkhead-mounted and connected to the oil gallery using an appropriate grade of lubricating oil hose. Any fittings used to connect the hose to the gallery must be of steel or malleable iron composition. Brass must **not** be used for this application.

### Raw Water Intake System

Make sure the intake system (raw water cooling system) is in proper order. Check that the hull inlet, sea cock and strainer are unobstructed. Sea cocks and strainers should be at least one size greater than the inlet thread of the raw water pump. The strainer should be of the type that may be withdrawn for cleaning while the vessel is at sea and should be mounted below the water line to ensure self-priming. Inspect the raw water lines to make sure there are no collapsed sections, which would restrict water flow. Make sure there are no air leaks at any of the connections.

### Cooling System

The generator's engine is fresh water-cooled by an engine-mounted heat exchanger. Raw water is used as the heat exchanger's cooling medium. Raw water is pumped into the exchanger by a raw water pump and is then injected into the exhaust for discharge, carrying with it the heat removed from the engine's fresh water cooling system.

Raw water should be supplied to the raw water pump through a flush-type through-hull fitting using a wire-reinforced hose between the through-hull fitting to the gasdenser and to the raw water pump. This raw water should be directed through a visual-type raw water strainer for delivery to the raw water pump. Hoses routed from the through-hull fitting to the raw water system on the engine should be wire-reinforced to prevent the hose from collapsing during the generator's operation (suction from the pump may collapse a non-reinforced hose). Raw water strainers should be mounted at or below the water line to make sure the strainer and line remain primed after shutdown.

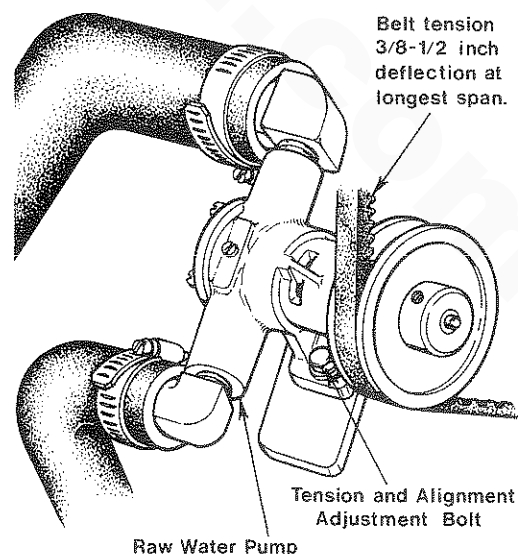



CAUTION

**Do not** use a scoop or weedless scoop-type through-hull fitting as a means of supplying raw water to the generator. Water pressure against this type fitting, while the vessel is under way, can push raw water past the raw water pump's impeller into the generator's exhaust system, filling it and the engine's cylinders as well. Flush-type, clear, through-hull fittings are recommended and should be located on the hull so as to be below the waterline during all angles of boat operation.

NOTE: Raw water entry into the engine cylinders is a warranty issue with the installer, **not** the Westerbeke Corporation

The use of common-type street elbows is not recommended for plumbing the raw water circuit. These generally have very restrictive inside diameters. Machined fittings with true inside diameters are preferred.

### Electrical System

The electrical system should be checked to make sure all wires and harnesses are properly tied down with clamps or plastic ties and that all wiring harnesses are supported at intervals close enough to prevent chafing from vibration. Check to make sure all engine harness connections are tight and that they are made to the appropriate terminals. Also, ensure that these terminals are not the recipients of bilge water or water from leaky hatch covers or corrosion will result.

### DC Electrical Connections

A tagged common ground stud for the negative (-) DC terminal connection is found at the bellhousing of the generator, next to the starter, in the form of a threaded grounding stud. The DC battery ground should be connected at this stud.

Connect the battery's positive (+) connection to the starter solenoid tagged for this connection.

CAUTION

To avoid an overcharging condition and a possible equipment failure, **do not** disconnect the DC battery source while the engine is running.

### Grounding

The generator set must be grounded to comply with United States Coast Guard regulation 33 CFR-183 which specifies that a common conductor be connected between the generator set and the vessel's main propulsion engine's grounded starter motor circuit. This conductor (the common ground) prevents accidental passage of cranking current through fuel systems and smaller electrical conductors common to the engines. This conductor must be the same size as the largest battery cable.

## Automatic Shutdown

### *High Exhaust Temperature Shutdown Switch (normally closed)*

An exhaust temperature switch is located on the exhaust elbow. This switch will open and interrupt the DC voltage to the ignition coil (which turns OFF the engine), should the switch's sensor indicate an excessive exhaust temperature (an inadequate supply of raw water coolant causes high exhaust temperatures). This switch opens at 260 - 270° F (127 - 132° C) and resets at approximately 225° F (107° C).

### *High Water Temperature Shutdown Switch (normally closed)*

A high water temperature switch is located on the thermostat housing. This switch will open and interrupt the DC voltage to the ignition coil (which turns OFF the engine), should the fresh water coolant's operating temperature reach approximately 205° F (96° C). This switch resets at 195° F (107° C).

### *Low Oil Pressure Shutdown Switch (normally open)*

A low oil pressure shutdown switch is located off the engine's oil gallery. The switch's is kept closed by engine oil pressure. Should the engine's oil pressure fall to 10 - 15 psi, the switch will open interrupting the DC voltage to the ignition coil (which turns OFF the engine).

### *High RPM Shutdown Switch*

An overspeed shutdown switch shuts OFF the generator set by grounding out the ignition system should the engine's speed reach approximately 2175 rpm. Reset this switch by momentarily depressing the STOP switch. (Make sure the cause of the engine overspeed shutdown is corrected.)

## Generator (AC Output)

Make sure that the AC output connections within the generator's distribution box are tight and in accordance with the specific AC Load Connections diagram found later in this manual. (See the "BC GENERATOR" section of this manual.)

## Batteries

Make sure the positive (+) battery connection is connected to the battery connection of the starting solenoid. The negative (-) battery connection should be connected to the system ground (the engine block).

### WARNING

**Do not** smoke or allow an open flame near batteries. Lead acid batteries emit hydrogen, a highly-explosive gas.

**WARNING**

When servicing the battery or checking the electrolyte level, wear rubber gloves, a rubber apron, and eye protection. Battery acid may splash on the skin or into the eyes inadvertently when removing the electrolyte caps.

Check the battery's electrolyte level and specific gravity to ensure maximum engine starting efficiency. Make sure the battery's terminals are clean and tight.

**Ventilation**

The ventilation requirements of the generator sets include the following: combustion air is required for the engine cylinders; cooling air is required for the generator end and also for removing the heat produced by the generator's engine during operation; and ventilating air is required to clear the bilges below the generator, as well as the compartment in which the generator is located, of potentially toxic and flammable gasoline vapors.

Keep in mind that hot air rises, so heated air should be removed from the upper area of the generator compartment and cool fresh air should be directed to the lower areas of the compartment. Ventilation should be accomplished with the aid of blowers especially when the vessel is not underway. Refer to the "SYSTEM SPECIFICATIONS" section of this manual for the airflow requirements of the generator set.

## DESCRIPTION OF ENGINE CONTROL PANEL

### General

The engine-mounted control panel is equipped with an ON switch, a START switch, and a STOP switch. The panel also has two fuses to protect the DC circuit. The three switches serve the following functions:

1. **ON Switch:** The ON switch provides power to the START circuit. This switch also bypasses the protective oil pressure shutdown switch until the engine's oil pressure reaches 10 - 15 psi once it is started.
2. **START:** The START switch energizes the starter's solenoid which cranks the engine. This switch will **not** operate unless the ON switch is depressed and held at the same time.
3. **STOP:** The STOP switch is used to stop the generator. This switch must be depressed and held depressed until the generator comes to a complete stop.

The engine mounted control panel has two protective fuses incorporated in it. A 15 amp fuse protects the start circuit and an 8 amp fuse protects the operating circuitry on the engine and any remote start/stop panel or instrument panel installed.

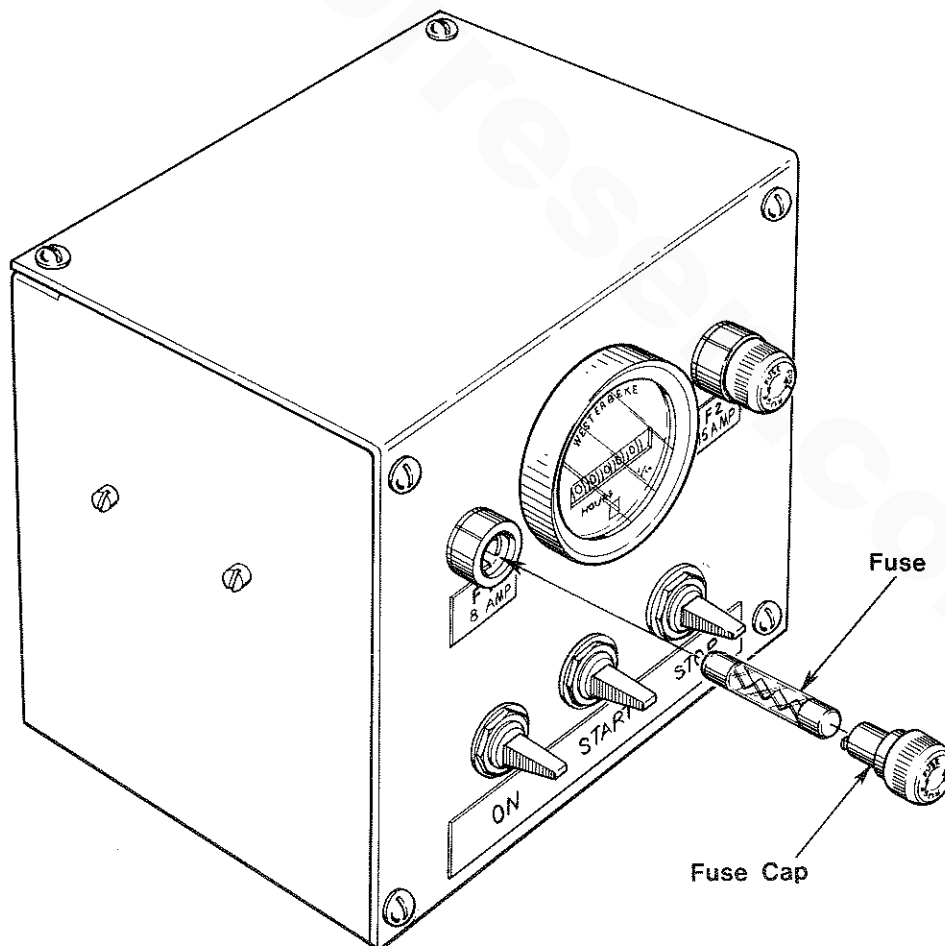

### Optional Remote Instrument and Remote Start Panels

An optional remote instrument panel is available, which includes starting controls. This panel also includes a water temperature gauge, oil pressure gauge, battery voltmeter, operating hourmeter and start-stop control switches.

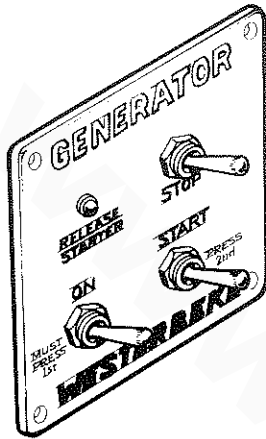

REMOTE START PANEL

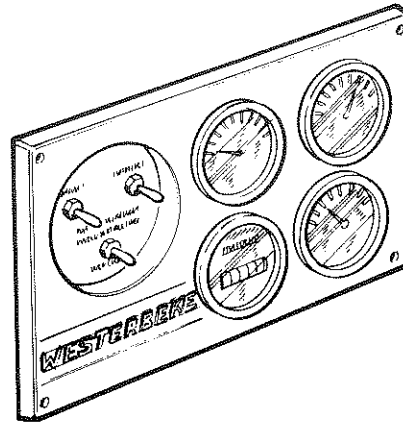

REMOTE INSTRUMENT PANEL

The remote instrument panel has with it two sending units to be installed on the engine block. One, a water temperature sender and the other, an oil pressure sender. Plugged ports for each are located on the engine. The water temperature sender is installed in the thermostat housing and the oil pressure sender is installed adjacent to the oil pressure switch. Use sealing compound on the threads of both senders when installing. Electrical connections for each sender are tied off adjacent to each sender's location.

NOTE: The blue colored connection is for the oil pressure sender and the tan colored connection is for the water temperature sender.

#### WARNING

When installing the optional remote start panel or the optional remote instrument panel, it is the installer's responsibility to comply with U.S. Coast Guard Standards 33 CFR PART 183.

An optional remote start panel is available for controlling the generator from a remote location.

Remote start panels include a green LED which lights when the engine runs at approximately 600 rpm. The purpose of the LED is to alert the operator to release the starter toggle switch in addition to continue indicating that the generator set is running.

## PREPARATIONS FOR STARTING

This section of the manual provides the operator with preparation, initial starting, break-in, starting (cold or warm), and stopping procedures. Follow the procedures as presented, for the conditions indicated, and your Westerbeke generator set will give you reliable performance and long service life.

Take the steps described below in starting your engine for the first time or after a prolonged shutdown or lay-up.

Fill your engine with oil up to but not over the upper limit on the dipstick (the installation angle of your generator set may have an effect on the dipstick reading). Select a readily available lubricating oil with an API specification of SE, SF or SG and an SAE number suitable for the temperature in your operating area. For the quantity of oil needed in your generator's engine, refer to the "SYSTEM SPECIFICATION" section of this manual.

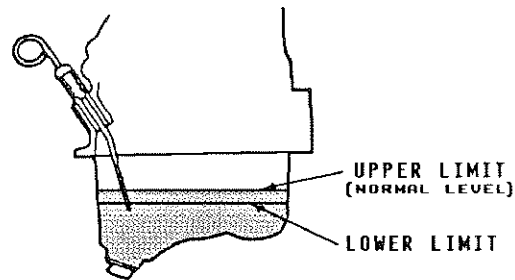

Each unit is supplied with a coolant recovery kit (part #24977) as standard equipment which must be installed and the following applies:

- A. Remove the pressure cap from the engine's exhaust manifold and slowly fill the engine's cooling system with a mixture of water and antifreeze suitable for your temperature zone. (See the "COOLING SYSTEM" section of this manual.) Replace the pressure cap on the manifold.
- B. Make sure the plastic recovery tank is properly mounted near the unit (with the bracket provided) in a location where it can be monitored and filled easily (see "COOLING SYSTEM"). The recovery tank should be mounted at manifold level or above, however, if the installation does not permit this, mounting it below the manifold is permitted.
- C. Coolant should be added to the plastic recovery tank after the engine has been filled and started. After its operating temperature has been reached, make sure all air is expelled out of the engine's manifold and the engine's cooling system. With the manifold filled completely and the pressure cap installed, fill the plastic recovery tank half full. Monitor this recovery tank daily and add coolant as needed.

Fill the fuel tank with unleaded or leaded gasoline that has an octane rating of 89 or higher.

## STARTING PROCEDURE

### WARNING

#### Carbon monoxide exhaust gas is deadly!

1. Ventilate the generator compartment for a minimum of 5 minutes prior to starting the generator. The ventilating blowers remove potentially explosive gasoline fumes from the generator compartment and bilge.
2. Depress the ON switch and hold it depressed for 5 to 15 seconds to make sure the fuel system on the engine is primed to the carburetor. Continuing to depress the ON switch, proceed to step #3.
3. Depress the START switch. When the generator starts, release only the START switch. Keep the ON switch depressed for a few seconds longer. (Keeping the ON switch depressed bypasses the oil pressure shutdown circuit until the oil pressure rises enough to close the switch internally and maintain the ignition circuit.)
4. Release the ON switch.

NOTE: The carburetor has an electric choke solenoid that closes the choke when the start switch is depressed, applying positive choke function during starting.

### CAUTION

When starting the generator, all AC loads, especially large motors, should be switched OFF until the engine has come up to speed and, in cold climates, starts to warm up. This precaution will prevent damage caused by the unanticipated operation of AC machinery and will prevent a cold engine from stalling.

### CAUTION

Prolonged cranking intervals without the engine starting can result in filling the engine-mounted exhaust system with raw water coolant. This may happen because the raw water pump is pumping raw water through the raw water cooling system during cranking. This raw water can enter the engine's cylinders by way of the exhaust manifold once the exhaust system fills. Prevent this from happening by closing the raw water supply through-hull shut-off, drain the exhaust muffler, and correct the cause for the excessive engine cranking needed to obtain a start. Engine damage resulting from this type of raw water entry is **not** a warrantable issue; the owner/operator should keep this in mind.

Once the engine starts, ensure raw water flow is discharged with the exhaust and check instruments, if instruments are installed, for proper oil pressure and battery charging voltage. **Never** attempt to engage the starter while the engine is running. Apply a light load to the generator and allow the engine's operating temperature to come up to 130 - 150° F (55 - 56° C) before applying any heavy loads.

NOTE: Some unstable running may occur in a cold engine, but this condition should smooth out as the operating temperature is reached (130 - 150° F [55 - 66° C]) and when a load is applied to the generator.

### **Break-In Precautions**

Because the generator set operates at 1800 rpm to produce 60 hertz, or at 1500 rpm to produce 50 hertz, control of the generator's engine break-in is governed by the current drawn from the generator. **Do not** attempt to break-in your generator set by running it without a load.

Upon starting the generator set, check for proper AC output and engine operation; both are related. For the first 10 hours of the generator's operation, run the generator set between 20 and 60 percent of full-load.

After the first 10 hours of the generator's operation, the load may be increased to the rated full-load output. Periodically vary the load.

Avoid overload at all times. An overload is signalled by a smoky exhaust with reduced output voltage and frequency. Monitor the current being drawn from the generator and keep it within the generator's rating.

Be aware of motor starting loads and the high current draw required for starting motors. This is upward of 3 - 5 times the amperage draw during normal running (see the "Amps for Starting" chart in the "GENERAL INFORMATION AND CARE OF THE GENERATOR" section).

### **Starting Under Normal Conditions**

Follow the procedure below for routine starting of the generator:

Check the engine's lubricating oil level prior to each day's use. Add oil as needed and maintain the oil level at the high mark on the dipstick.

Check the coolant level in the plastic recovery tank.

**NOTE:** Excessive loss of fresh water coolant from the plastic recovery tank indicates a cooling system leak. Check the entire cooling system, as well as the coolant recovery system, and pressurize the system to locate the leak. In cases of excessive coolant loss, the system must be refilled as outlined under the "PREPARATIONS FOR STARTING" section of this manual.

Visually examine the unit; look for any abnormalities and correct them as needed.

Check to make sure there is sufficient fuel in the tank and examine the filter/water separator bowl for contaminants. Clean and drain the bowl as needed.

Start the generator, following the procedure outlined in the "STARTING PROCEDURE" section, and allow the engine's operating temperature to reach 130 - 150° F (55 - 66° C) before placing the generator under a heavy load.

### **Starting Under Cold Conditions**

Under extremely cold temperatures, the following conditions can occur. Follow the instructions listed below when operating your generator set in cold weather.

*Lubricating oil turns viscous* - Make certain that the lubricating oil used conforms with the ratings for the prevailing atmospheric temperature. Refer to the "LUBRICATION SYSTEM" section of this manual for an atmospheric/oil viscosity specification table.



*Voltage across battery terminal drops* - Make certain that the battery is fully charged to minimize voltage drop across the battery terminals.

### Remote Starting Procedure

The remote start panel is the same as the engine-mounted start panel except that it has a green LED light. When starting at a remote location, the green LED lights when the generator is running at approximately 600 rpm. This indicates when the START switch can be released since the starting of the generator may not be audible.

- A. When starting the generator set at a remote location, release the START switch when the green LED lights but continue depressing the ON switch. After releasing the START switch, continue holding the ON switch until the oil pressure is sufficient to close the oil pressure safety switch, providing the normal B + path to the ignition system.
- B. After the generator is started, the generator's starter will **not** crank until someone again operates the ON switch first.

## STOPPING PROCEDURE

1. Remove the AC electrical load from the generator and allow the generator to run for 3 to 5 minutes to stabilize its operating temperatures.
2. Depress the STOP switch and hold it until the generator is completely stopped.
3. Now release the STOP switch.

### Remote Stopping Procedure

To STOP the generator, depress the STOP switch which opens the normally closed B + path for voltage to the engine's ignition circuit. The STOP switch *must* be held open until the generator comes to a complete stop. Remote start panels may be connected to the generator set as indicated. A jumper has to be removed between the T-1 and T-2 connections at the panel connection terminal board. (Refer to the wiring diagram in the "ELECTRICAL SYSTEM" section of this manual.)

### Overspeed Shutdown

Should the generator shut down from an overspeed condition, the overspeed circuit *must* be reset before attempting to restart the generator. Resetting the overspeed switch is done by simply depressing the STOP switch momentarily and then proceeding with the normal starting procedure.

If the overspeed switch itself is faulty and resetting it by depressing the STOP switch will not reset the circuit, lift the T-1 coil connection from the switch and tape the end of the T-1 wire with electrical tape. **Do not** operate the generator with the overspeed switch bypassed. Bypass this circuit only to test the overspeed circuit. Replace the overspeed switch to maintain this safety circuit's integrity.

### WARNING

**The overspeed shutdown must always be installed and functioning.** Any tampering with the overspeed shutdown module, which would cause it to malfunction, could be a cause of injury should the generator's belt-driven governor fail and cause the generator drive engine to overspeed.

### CARBURETOR AND FUEL SYSTEM

#### Gasoline

Use unleaded or leaded gasoline with an octane rating of 89 or better.

In cold weather particularly, water vapor is produced by condensation when air is present in the fuel tank. Keep fuel tank(s) full and completely free of dirt and water.

The carburetor is a single barrel, down-draft type with a cleanable metal screened air intake filter/spark arrester.

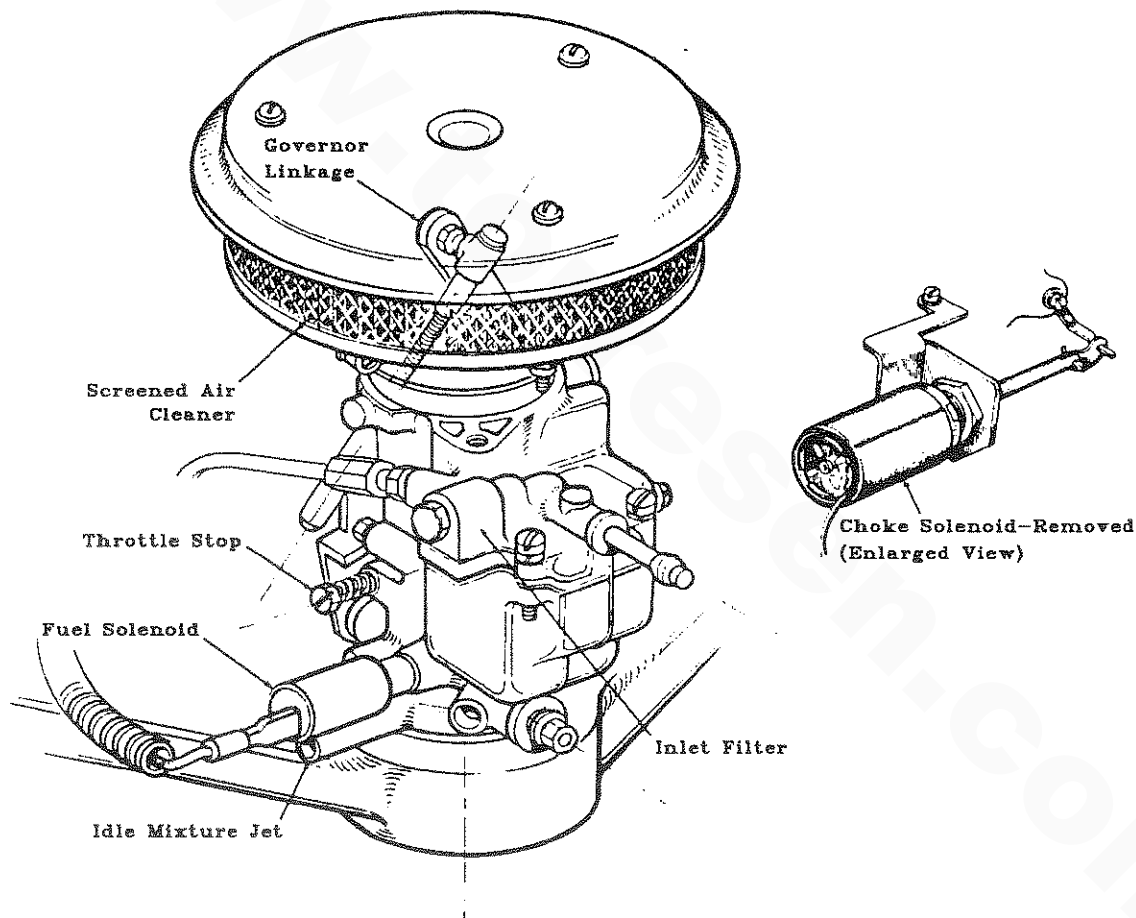

### Optional Fuel Filter/Water Separator

A primary fuel filter of the water separating type *must* be installed between the fuel tank and the engine. This is to remove water and other contaminants from the fuel before they can be carried to the fuel system on the engine where they can cause unwanted engine stoppage and damage to the fuel system equipment on the engine.

Most installers do include with the generator installation package a type of filter/water separator for they are aware of the problems contaminants in the fuel can cause - all of which are not warrantable through Westerbeke.

A typical fuel filter/water separator is illustrated at the right. This is the Raycor Model 110 and is approved for use with marine gasoline products. A filter/water separator of this type should be part of your installation's fuel system.

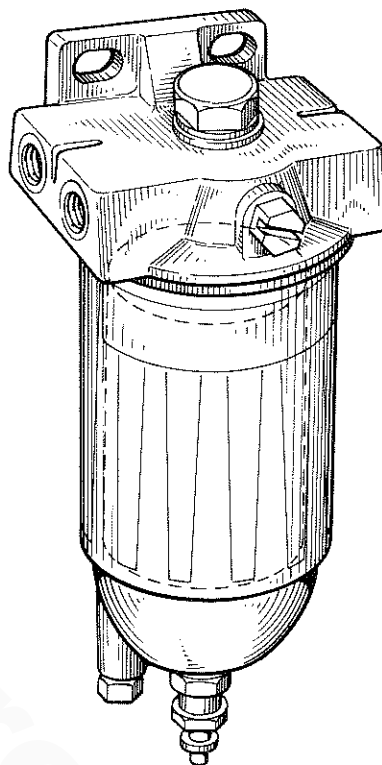

### Replacing Filter Elements

The generator model covered by this manual has one fuel filter screen referred to as the inlet filter screen.

To remove the filter screen, unscrew the filter plug and remove the fuel filter screen behind the plug.

Clean the filter screen or replace it with a new one.

Periodically check this filter screen.

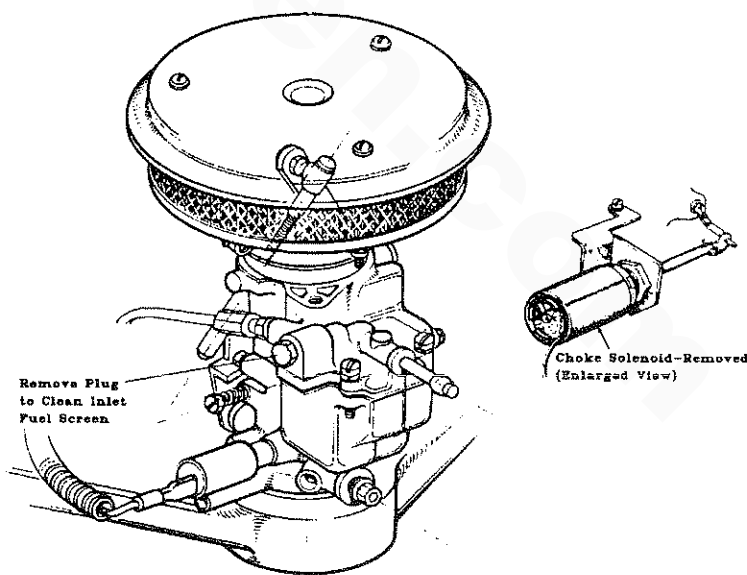

The engine mounted fuel pump requires little or no maintenance. Ensure fuel being supplied to this pump is free of water or other types of contaminants that will hinder the pumps operation.

Periodically check the fuel connections to and out of the pump and make sure that no leakage is present and that the fittings are tight and secure. Also, check that the DC electrical connection supplying 12 volts DC to the pump is clean, tight and secure. The DC ground connection at one of the pumps mounting bolts should be clean and well secured by the mounting bolt to ensure proper pump operation.

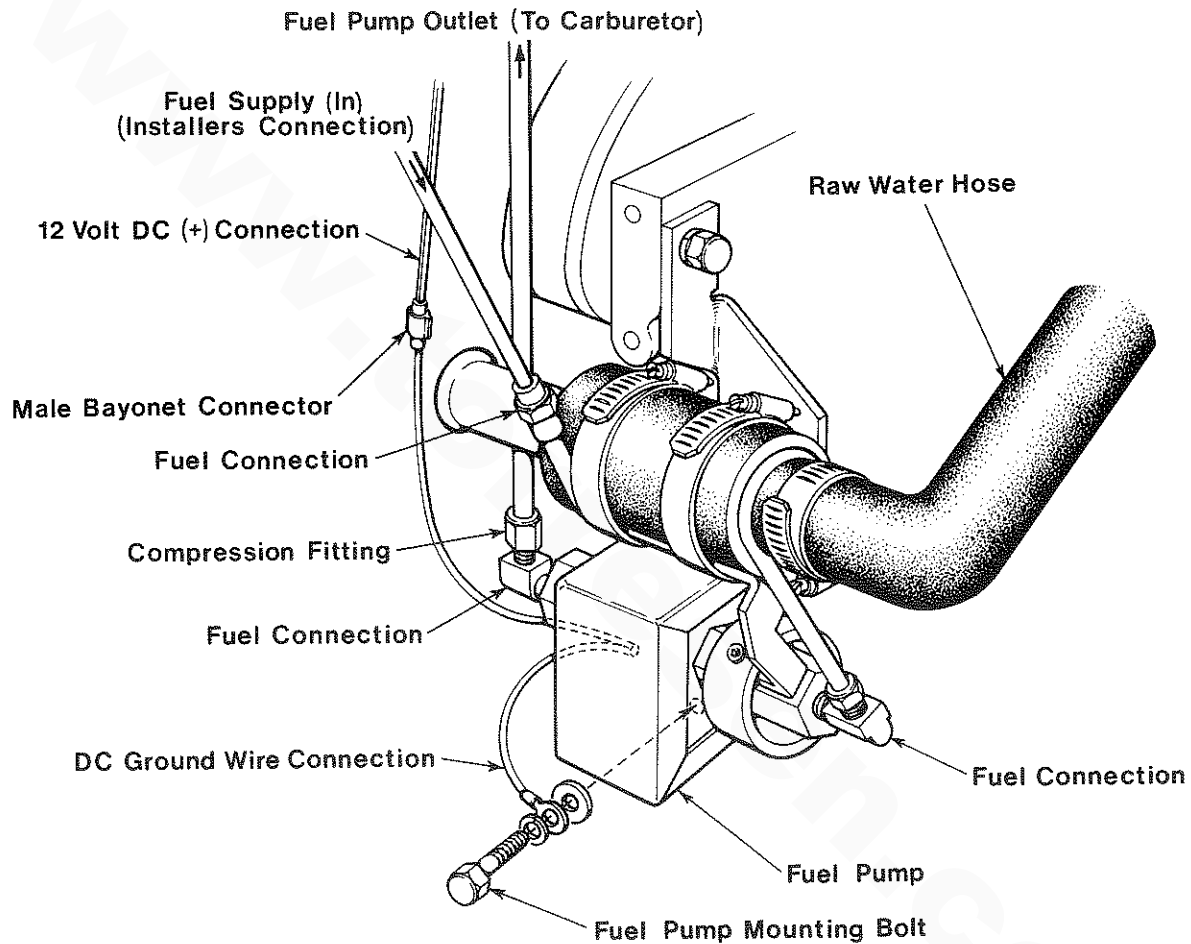

**WARNING**

Fuel leakage at the fuel pump or its connections is a fire hazard and should be corrected. Make sure proper ventilation exists whenever servicing fuel system components.

## ELECTRICAL SYSTEM

### Engine 12-Volt DC Control Circuit

The engine that drives the generator end has a 12-volt DC electrical control circuit, as shown on the wiring diagram which follows in this section. Refer to these diagrams when troubleshooting or servicing electrical components on the engine.

#### CAUTION

To avoid damage to the battery's charging circuit, **never shut off the engine's battery switch while the engine is running.**

However, shut off the engine's battery switch to avoid electrical shorts when working on the engine's electrical circuit with the engine stopped.

An overspeed shutdown switch shuts off the generator set should the engine's speed reach approximately 2175 rpm. This shutdown circuit consumes 25 milliamps (.25 or 1/4th of an amp) at all times once the generator is connected to its battery. As this only amounts to about 18 amp-hours in a month, it is unnecessary to be concerned with this slight discharge during normal seasonal operation. If the generator set were to be unattended for many months, the two easiest ways to stop this slight drain is to first turn off the main battery switch providing 12 volts to the generator set. The second way to stop this slight drain is to remove the ignition fuse on the generator-mounted control panel.

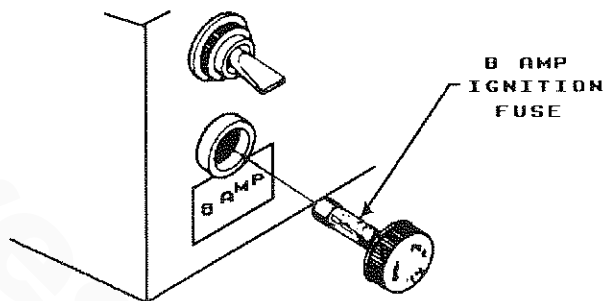

Should the generator shutdown from an overspeed condition, the overspeed circuit *must* be reset in order to restart the generator. If the overspeed switch itself is faulty and resetting it by depressing the STOP switch will not reset it, lift the T-1 coil connection from the overspeed switch and tape the terminal end with electrical tape. **Do not** operate the generator with the overspeed switch bypassed. Bypass the overspeed switch only for testing purposes. Replace the overspeed switch to maintain this safety circuit's integrity.

### Battery Specification

The minimum recommended capacity of the battery used in the engine's 12-volt DC control circuit is 24 - 28 ampere-hours (minimum) for the generator set covered by this manual.

#### CAUTION

When quick-charging the battery with an external charger, be sure to disconnect the battery cables from the battery. Leaving the charging circuit connected while quick-charging will damage the diodes in the integral controller's circuitry.

### Testing the Battery Charging Circuit

#### 1. AC Stator Winding : 0.14 Ohm

Lift the two AC leads off the bridge rectifier and measure with an ohmmeter the resistance between these two leads which should measure 0.14 ohm. No continuity should exist between these two leads and the ground.

#### 2. Bridge Rectifier

Normal AC voltage running to the rectifier (while the engine is operating at 1800 rpm) is measured across the two AC connections on the bridge rectifier. (See the illustration below.)

AC voltage running to the bridge rectifier (approximate):

No-load off the generator	16.0 volts AC
Full-load off the generator	17.5 volts AC

Normal DC voltage running out of the rectifier (in volts DC) is measured across the two DC connections of the bridge rectifier; that is, + and - .

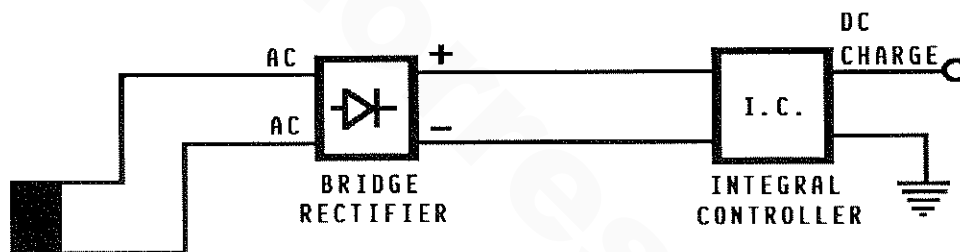

DC voltage running from the bridge rectifier (approximate):

No-load off the generator	17.0 volts DC
Full-load off the generator	18.5 volts DC

#### 3. Testing the Bridge Rectifier

A. Set your ohmmeter's scale on RX1 (+ DC) and set the needle to zero.

B. Connect the (+) positive lead from the ohmmeter to point #4. Taking the ohmmeter's negative (-) lead, momentarily touch points #1, #2, #3, and #5. The ohmmeter should register no deflection for any of the points touched.

C. Remove the positive (+) lead from point #4 and connect the negative (-) lead to point #4. Touch points #1, #2, and #3. The needle should deflect, indicating a passage of current through the diodes located internally at these points.

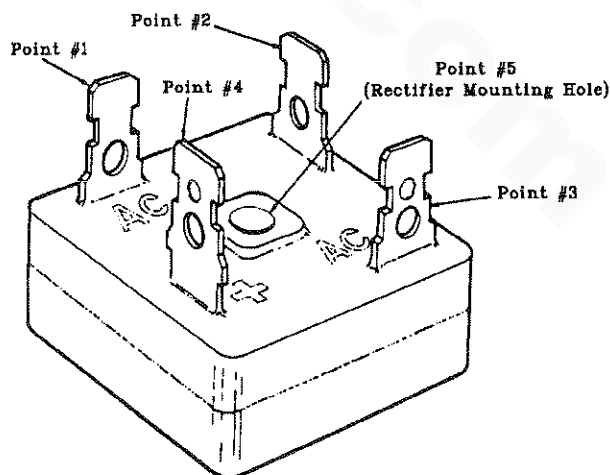

D. With the (-) negative lead still connected to point #4, touch point #5. The needle should not deflect.

E. Place the (+) positive lead on point #1 and the (-) negative lead on point #3. The ohmmeter again should not register any deflection (no deflection indicated infinite resistance). Reverse these connections and the ohmmeter should again register no deflection. If the rectifier fails any of the previous tests (A - E), replace the rectifier because it is defective.

NOTE: Various style/model meters may produce test results directly opposite from tests B-E. In such tests, the results are as above.

#### 4. Integral Controller (I.C.)

The integral controller (I.C.) is an encapsulated, solid-state unit that supplies a DC charging voltage to the generator's starting battery while the generator is operating.

Charging Voltage: 13.0 - 14.0 volts DC  
Charging Amperage: 0 - 10 amps DC

A separate group of stator windings supplies AC voltage to a bridge rectifier which converts the AC current into DC current to supply the I.C. unit. The I.C. unit senses the needs of the starting battery and supplies a DC charge when one is needed. If you suspect that the I.C. unit is faulty (that is, if the battery's charge is low), check the charging circuit's components and performance by following steps #1 - 3. Check all connections for cleanliness and tightness including the ground before replacing the I.C. unit.

NOTE: When the generator is first started, the I.C. unit will produce a low charging rate. This charging rate will rise as the generator is operated for awhile.

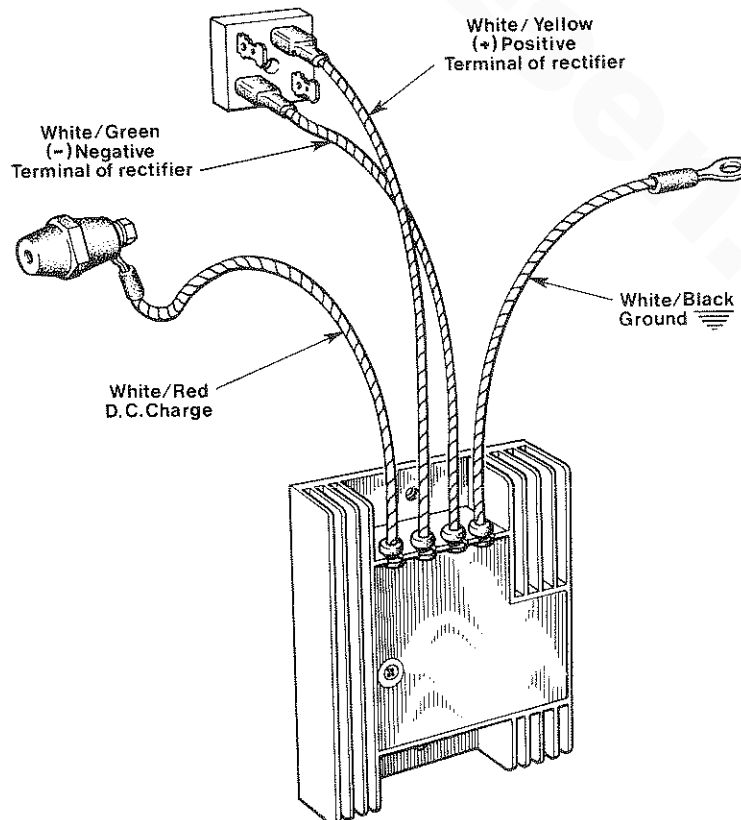

NOTE: White / Green (-) Negative and White / Black Ground are interchangeable.



DC CONTROL CIRCUIT WIRING DIAGRAM #38028

Page 1 of 2

WIRING DIAGRAM

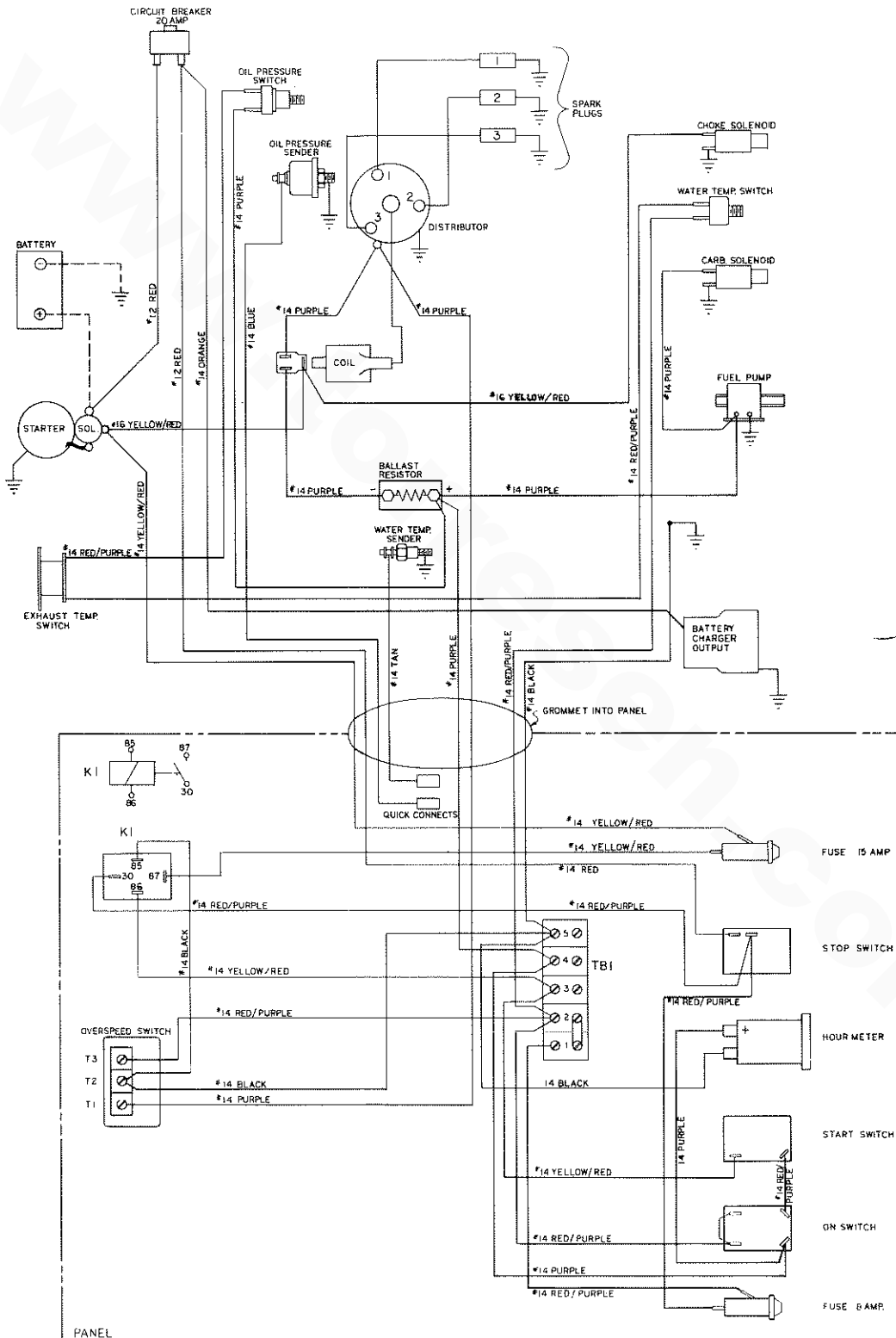

DC CONTROL CIRCUIT WIRING DIAGRAM #38028

Page 2 of 2

SCHEMATIC DIAGRAM

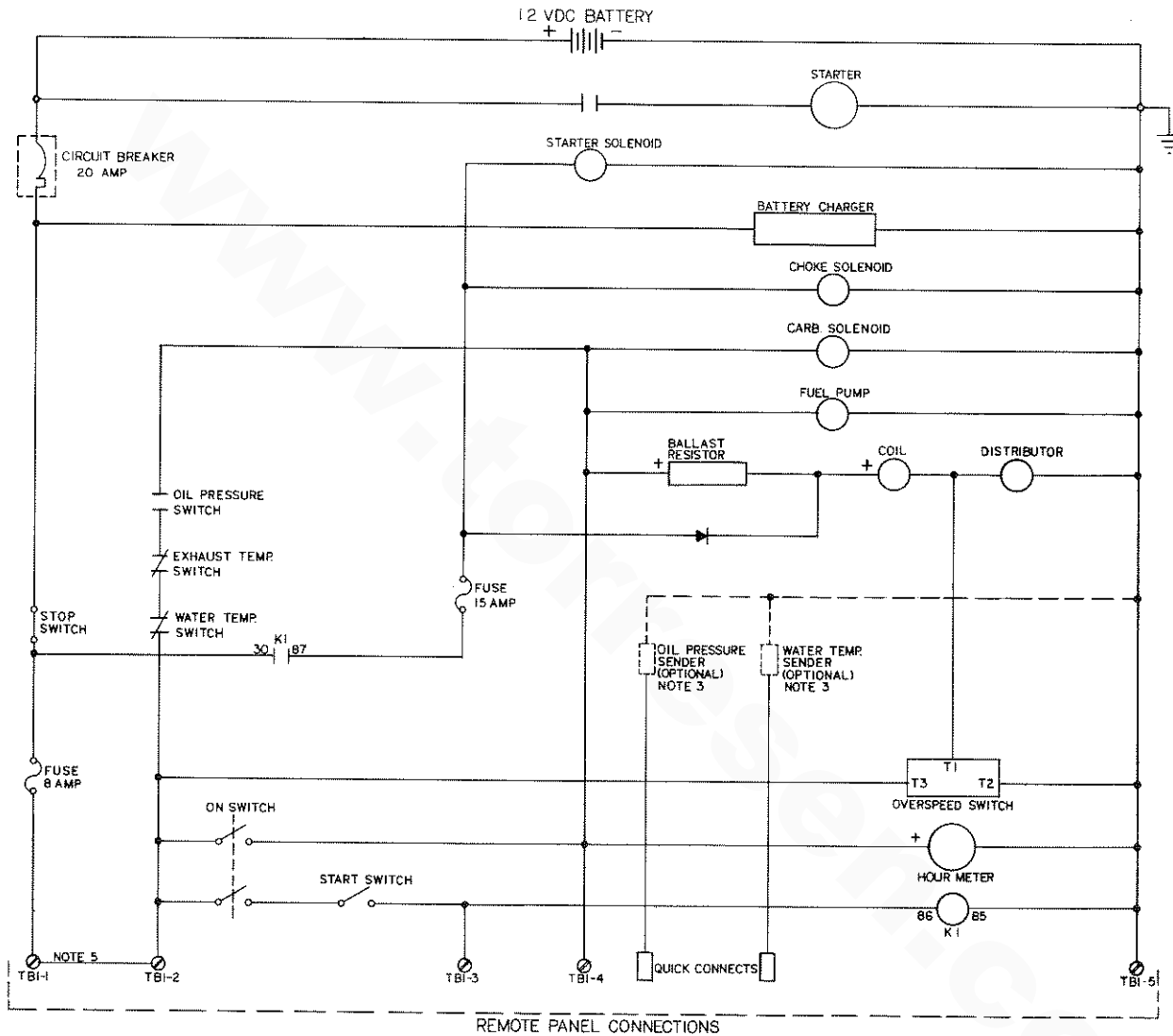

RESPONSIBILITY FOR SAFETY REGULATIONS

1. BATTERY CHARGER CAUSES A 9mo DRAIN AND OVERSPEED MODULE CAUSES A 15mo DRAIN WHEN GENERATOR IS NOT OPERATING. THEREFORE, WHEN LEAVING BOAT FOR AN EXTENDED PERIOD, DISCONNECT THE BATTERY.
2. WESTERBEKE GASOLINE MARINE GENERATORS, AS SHIPPED FROM THE FACTORY AND EXCLUSIVE OF OPTIONAL REMOTE INSTRUMENT OR CONTROL PANELS, COMPLY WITH U.S. COAST GUARD 33CFR-183. ACCESSORY INSTRUMENT AND CONTROL PANELS DO NOT NECESSARILY SO COMPLY AND ARE INTENDED TO BE INSTALLED ABOVE DECK AND "ISOLATED FROM GASOLINE SOURCES" IN ACCORDANCE WITH 33CFR-183.410(b). IT IS THE RESPONSIBILITY OF THE BOAT MANUFACTURER TO INSURE THAT THE INSTALLATION OF THESE GENERATORS AND OPTIONALLY, THEIR REMOTE INSTRUMENT OR CONTROL PANELS, COMPLY WITH 33CFR-183.
3. SENDERS SUPPLIED WITH OPTIONAL INSTRUMENT PANEL.
4. MINIMUM RECOMMENDED WIRE GAUGE TO REMOTE PANEL IS No. 14 AWG.
5. REMOVE JUMPER BETWEEN TBI-1 AND TBI-2 WHEN USING REMOTE PANEL.

OPTIONAL REMOTE START PANEL WIRING DIAGRAM # 38024

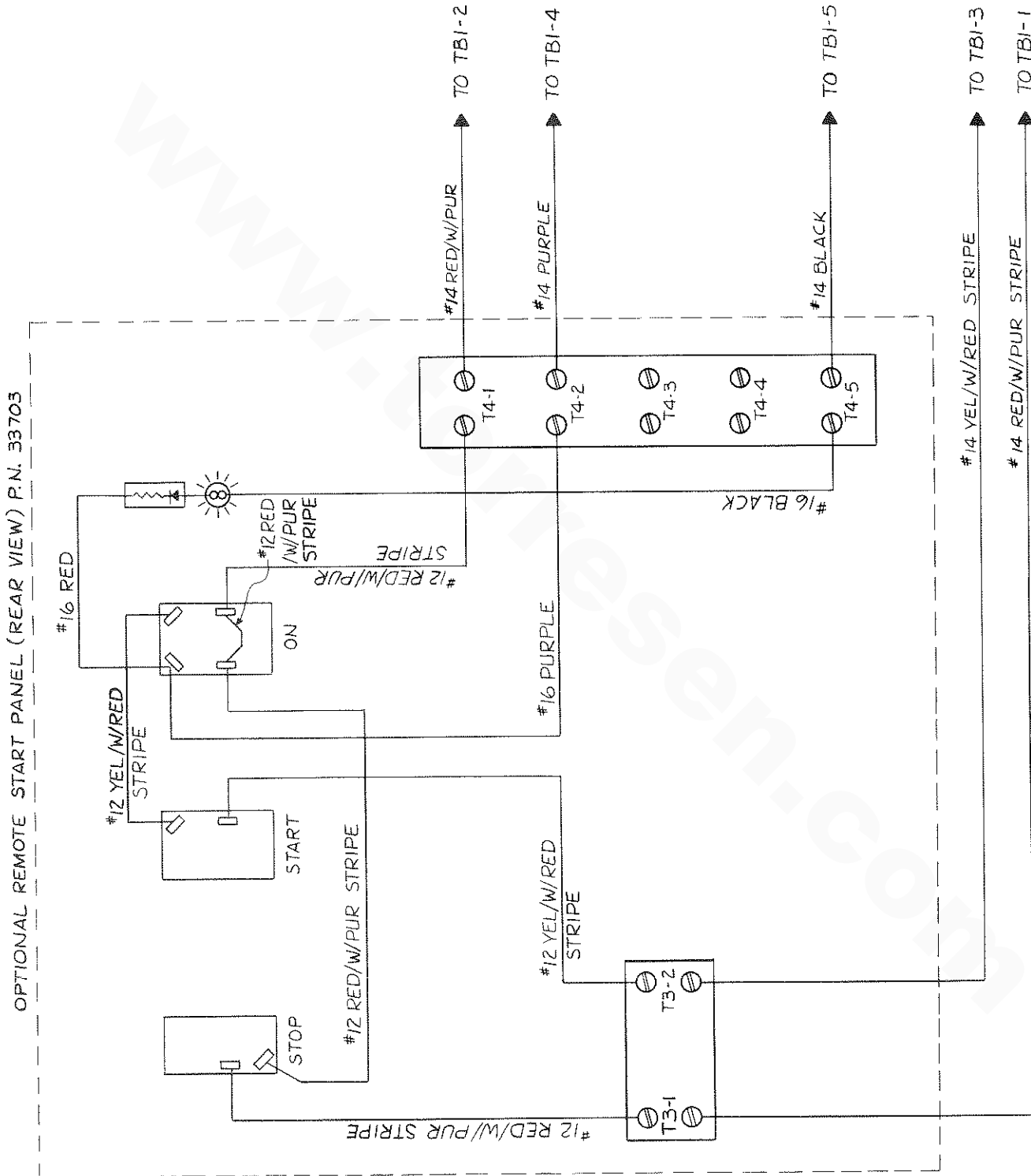

OPTIONAL REMOTE INSTRUMENT PANEL WIRING DIAGRAM # 38025

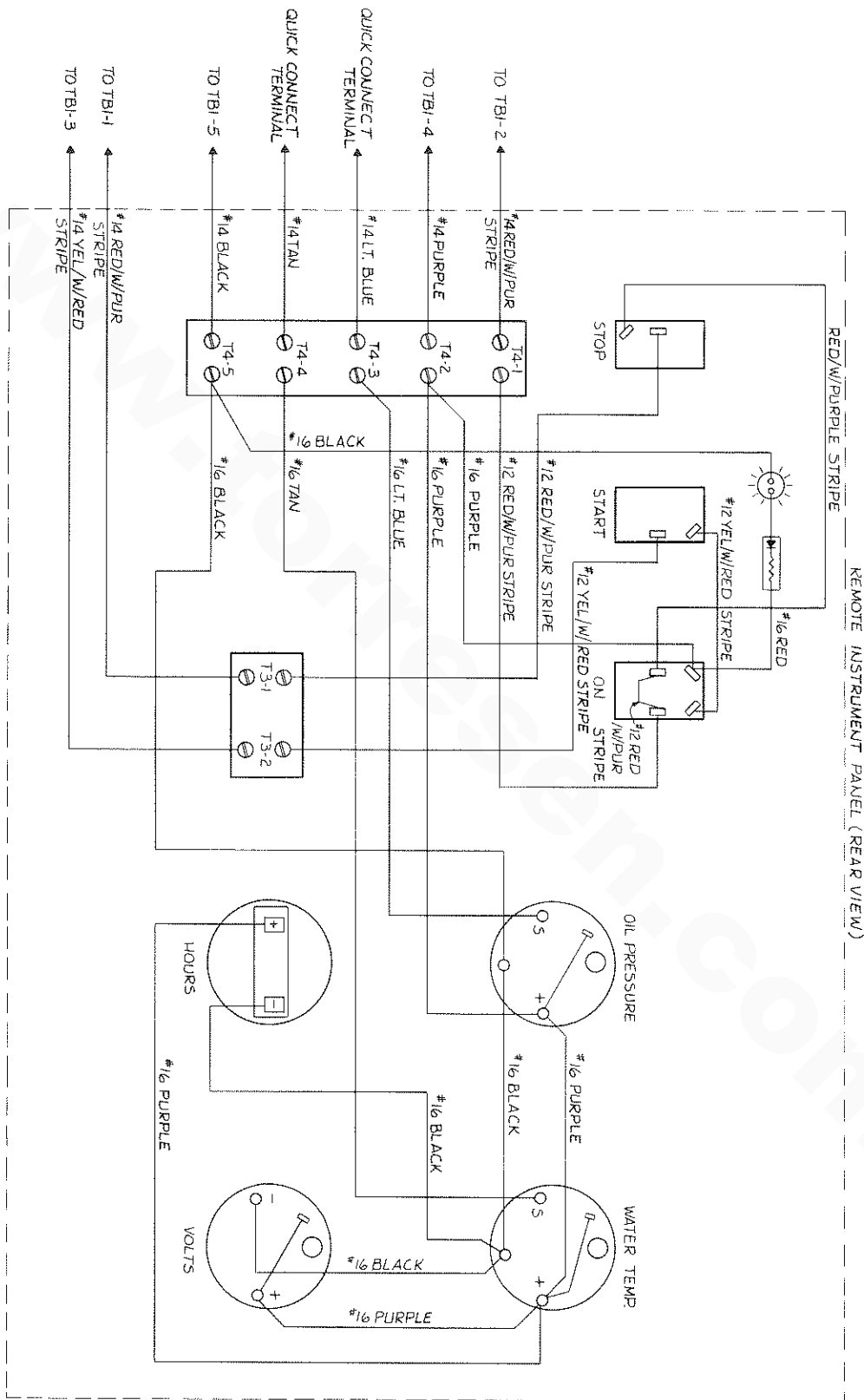

## COOLING SYSTEM

### Description

Westerbeke marine gasoline engines are designed and equipped for fresh water cooling. Heat produced in the engine by combustion and friction is transferred to the fresh water which circulates throughout the engine. This circulating fresh water cools the engine block and its internal moving parts. The heat is transferred externally from the fresh water to raw water by means of a heat exchanger, similar in function to an automotive radiator. Raw water flows through the tubes of the heat exchanger while fresh water flows around the tubes; engine heat transferred to fresh water is conducted through the tube walls to the raw water which is pumped into the exhaust system and discharged overboard. In basic terms, the engine is cooled by fresh water, the fresh water is cooled by raw water, and the raw water carries the transferred heat over the side through the exhaust system. The fresh water and raw water circuits are independent of each other. Using only fresh water within the engine allows the cooling water passages to stay clean and free from harmful deposits. The two independent circuits and their components are discussed in the following paragraphs.

### Fresh Water Circuit

**NOTE:** Refer to paragraphs **A** and **B** in this section on the recommended antifreeze and water mixture used as the fresh water coolant, and for information on filling the fresh water system.

Fresh water is circulated through the engine by a belt-driven circulating pump, absorbing heat from the engine. It then passes through the thermostat into the exhaust manifold, then to the heat exchanger where it is cooled, and then is returned to the engine block through the suction side of the fresh water circulating pump. When the engine is started cold, external fresh water flow is prevented by the closed thermostat (although some fresh water flow is bypassed around the thermostat to prevent the exhaust manifold from overheating). As the engine warms up, the thermostat gradually opens, allowing the engine's fresh water coolant to flow unrestricted to the external portion of the cooling system.

#### A. Fresh Water Coolant (Antifreeze) Mixture.

A freshwater and antifreeze mixture should be used year-round. Water, when it freezes, expands sufficiently to split the heat exchanger and crack the engine block. A water/antifreeze mixture of proper concentration will prevent freezing and promote better heat transfer (see next page for an antifreeze/water mixture chart).

Use soft water with few impurities, such as tap water (potable water) or rainwater. **Never** use hard or foul water. Use of hard water or water containing impurities will lead to the collection of scale in the engine and heat exchanger which will reduce the cooling system's efficiency.

Antifreeze of poor quality or without rust inhibitors will cause corrosion within the cooling system. Always use antifreeze which is compatible with aluminum cooling system components and which is made by a reliable manufacturer. **Never mix different brands of antifreeze.** Recommended antifreeze for year round use is ZEREX or PRESTONE with rust inhibitors.

Make sure that the cooling system of the engine is well cleaned before adding antifreeze.

In order to control the concentration of the mixture, mix the antifreeze and fresh water thoroughly before adding it to the cooling system.

ANTIFREEZE CONCENTRATION DATA

Antifreeze Concentration	%	13	23	30	35	45	50	60
Freezing Temperature	° F	23	14	5	-4	-22	-40	-58
	(° C)	(-5)	(-10)	(-15)	(-20)	(-30)	(-40)	(-58)

NOTE: An antifreeze concentration should be selected on the basis of a temperature which is about 10° F (5° C) lower than the actual atmospheric temperature expected.

**B. Filling the Fresh Water System**

A coolant recovery tank kit, PN 024977, is supplied with each Westerbeke gasoline generator. The purpose of this recovery tank is to allow for engine coolant expansion and contraction, during engine operation, without the loss of coolant and without introducing air into the cooling system.

This coolant recovery tank should be installed at, or above, the engine's manifold level, in a location where it can be easily monitored and where coolant can be easily added, if needed (see the figure below). A stainless steel mounting bracket is supplied with each kit along with a 30 inch length of clear plastic hose and clamps to connect the hose between the engine's manifold fitting to the hose spud on the base of the recovery tank.

Coolant Recovery Tank, Recommended Installation

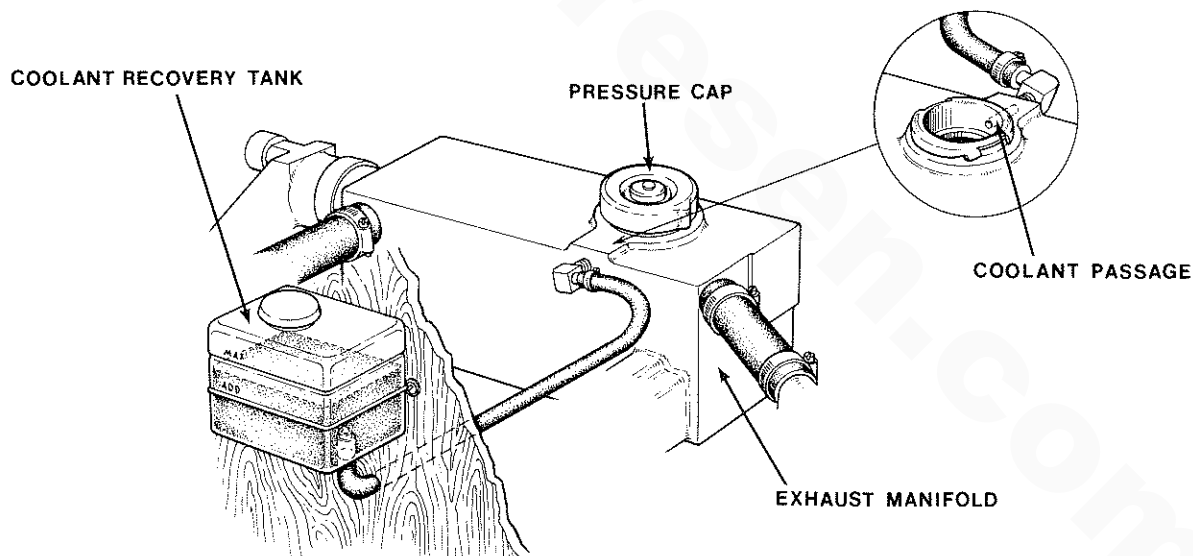

NOTE: Coolant loss can occur at the connection points of the plastic hose, at the manifold fitting, and the tank spud and go undetected when this coolant leaks onto the hot exhaust manifold and evaporates. Check these connections when troubleshooting the cooling system for coolant loss.

FUNCTION OF MANIFOLD PRESSURE CAP

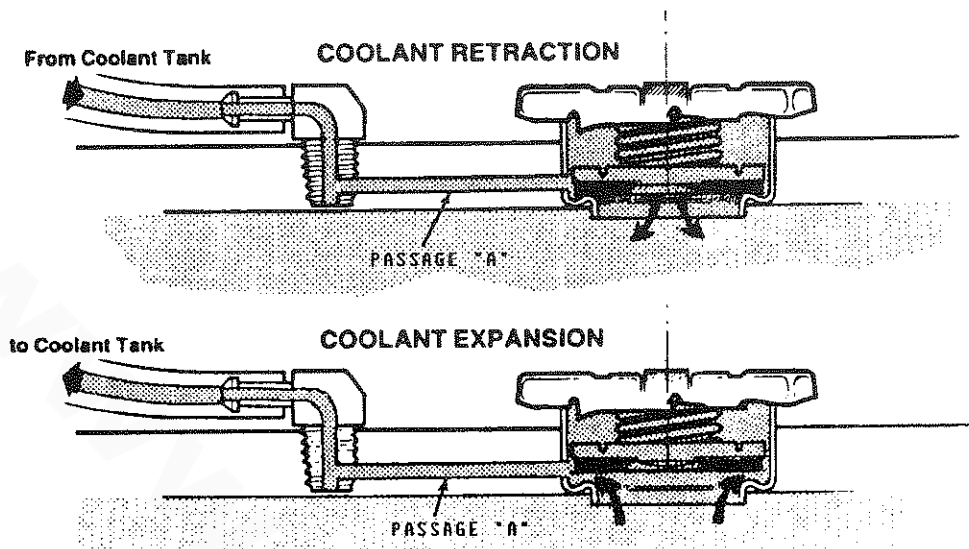

Coolant from the engine, when heated during the engine's operation, will expand, lift the spring-loaded manifold pressure cap and enter the recovery tank via the hose connecting the recovery tank to the manifold. When the engine is shut down and cools, a small check valve in the pressure cap is opened by the contraction of the engine's coolant allowing some of the coolant in the recovery tank to be drawn back into the engine's cooling system, free of air and without loss. Periodically check that the passage (A) between the 90° fitting on the manifold and the filler neck in the manifold is clear so coolant can flow in either direction.

Fill the fresh water system as follows:

1. Remove the pressure cap from the manifold.
2. Pour a clean, water/antifreeze mixture into the manifold and allow enough time for the coolant mixture to fill the fresh water cooling system and expel all air.
3. Replace the pressure cap on the manifold.
4. Remove the plastic cap from the coolant recovery tank and fill the tank with coolant mixture halfway between the **ADD** mark and the **MAX** mark. Replace the cap on the manifold.
5. Start and run the engine long enough for the engine to warm up so the thermostat will open, allowing the coolant mixture to flow through the engine block and to the rest of the fresh water cooling system.
6. Add coolant mixture to the recovery tank, as required, to top off the fresh water cooling system. (Periodically check that the manifold is completely full and no air pocket is present.)

**Thermostat**

The thermostat used is simply a choke device that remains closed causing the coolant mixture in the engine block to rise in temperature. This temperature rise effects the thermostat causing it to open; thus, allowing coolant mixture to circulate through the cooling system.

**Raw Water Circuit**

The raw water flow is created by a belt-driven, positive displacement, neoprene impeller pump. The pump draws raw water directly from the ocean through the sea cock and raw water strainer and passes the water to the heat exchanger's raw water inlet. The raw water passes through the heat exchanger's tubes, from around which the fresh water coolant mixture circulates. Heat from the fresh water system is absorbed and then is discharged from the cooling system overboard through the water-injected wet exhaust system.

**Raw Water Pump**

The raw water pump is a self-priming, belt-driven rotary pump with a non-ferrous housing and a neoprene impeller. The impeller has flexible vanes which wipe against a curved cam plate within the impeller housing, producing the pumping action. **On no account should this pump be run dry.** There should always be a spare impeller and impeller cover gasket on board (an impeller kit).

NOTE: Impeller failures resulting from a loss of raw water coolant are **not** warrantable failures. Self priming occurs when the engine mounted pump is close to or below the water line of the vessel.

**Zinc Anodes**

A zinc anode, or pencil, is located in the raw water cooling circuit within the heat exchanger. The purpose of the zinc anode is to sacrifice itself to electrolysis action taking place in the raw water cooling circuit, thereby reducing the effects of electrolysis on other components of the system. The condition of the zinc anode should be checked monthly and the anode cleaned or replaced, as required. Spare anodes should be carried on board.

NOTE: Electrolysis action is the result of each particular installation and/or vessel location; not that of the generator. Generators do not produce electrolysis.

If the zinc pencil needs replacement, **hold the hex boss into which the zinc pencil is threaded with a wrench while loosening the anode with another wrench.** This prevents the hex boss from possibly tearing off the exchanger shell. After removing the zinc, note the condition of it. If the zinc is in poor condition, there are probably a lot of zinc flakes within the exchanger. Remove the end of the heat exchanger and clean the inside of all zinc debris. **Always have a spare heat exchanger end gasket in case the present one becomes damaged when removing the end cover.** Replace the gasket (refer to your engine model's heat exchanger end gasket part number), cover, and install a new zinc pencil.

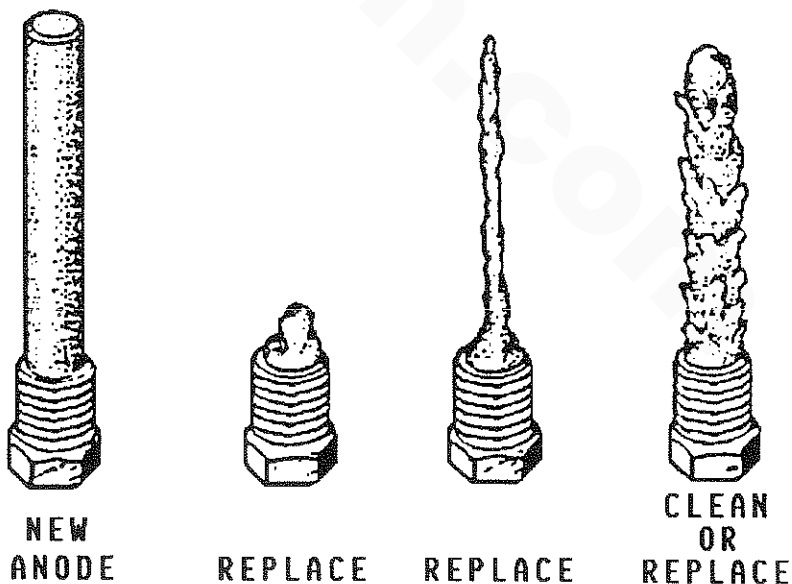



### Governor/Fresh Water/Raw Water Pump Belt Tension

**WARNING**

Never attempt to adjust the drive belt's tension while the engine is in operation.

**CAUTION**

Excessive governor and water pump drive belt tension can cause rapid wear of the belt and reduce the service life of the fresh water pump and governor shaft bearings. Excessive slack or the presence of oil on the belt can cause belt slipping, resulting in high operating temperatures, as well as poor regulation during generator load changes.

The governor and water pump drive belt is properly adjusted if the belt can be deflected no less than 3/8 inch and no more than 1/2 inch (10 mm, 12 mm) as the belt is depressed with the thumb at the midpoint between the two pulleys on the longest span of the belt. (See the figure below.) A spare drive belt should be carried on board.

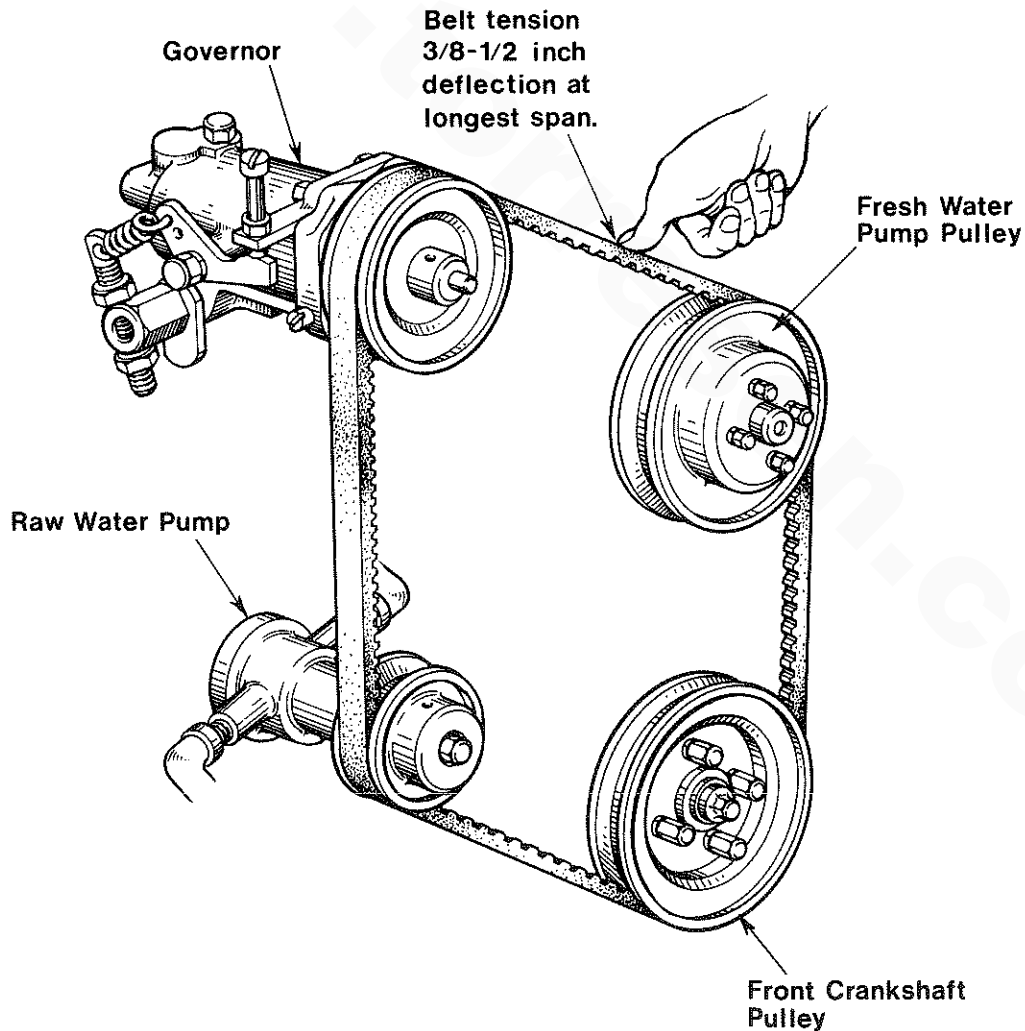

Governor/Fresh Water/Raw Water Pump Belt Tension

**Cooling System**

Illustrated below is a typical Westerbeke engine's cooling system. Both fresh water and raw water flow through their independent cooling circuits. Please refer to the Parts List for individual part numbers and descriptions for your generator's cooling system.

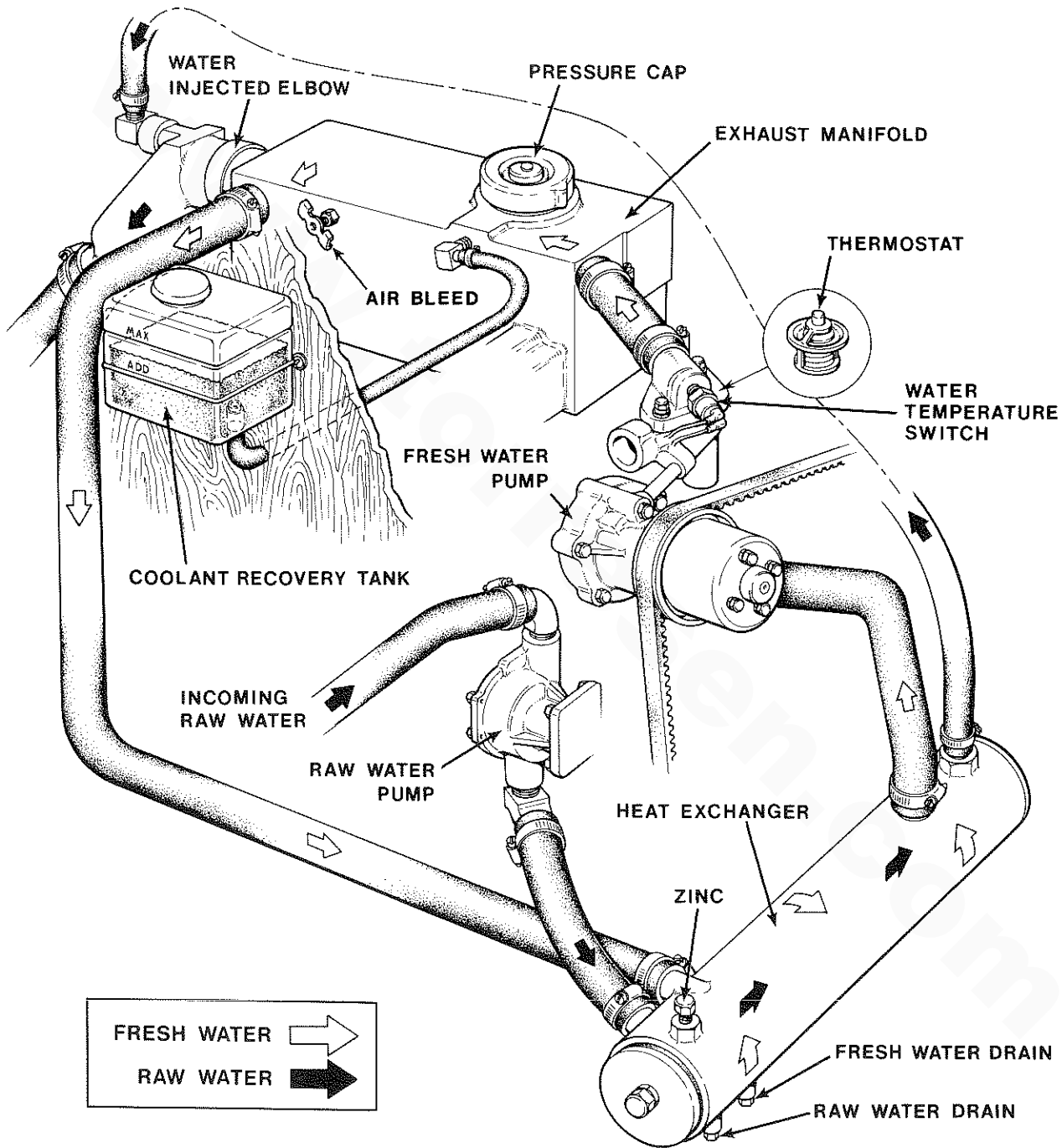

Typical Cooling System

**LUBRICATION SYSTEM**

**Engine Oil**

For the engine's lubrication, use a lubricating oil designated for gasoline service. Use a good grade of oil having an API specification of SE, SF or SG. Do not use oils designated DS.

**Engine Oil Viscosity (SAE Number)**

Use oil having a viscosity best suited to the atmospheric temperature. Refer to the oil viscosity chart below.

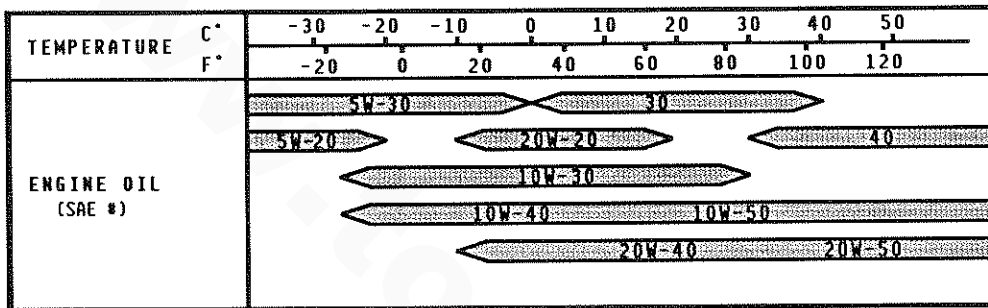

**Oil Pressure**

The engine's oil pressure is indicated by the oil pressure gauge (when equipped with one) or is monitored by the standard oil pressure switch.

During normal operation, the engine's oil pressure will range between 35 and 55 psi (engine hot).

NOTE: A newly started, cold engine can have an oil pressure reading upwards of 60 to 80 psi. A warmed engine can have an oil pressure reading as low as 35 psi. These readings may also vary depending upon the load that is placed on the generator.

Your generator set is fitted with an oil pressure sensing switch as standard equipment. Should your engine's oil pressure drop below a safe operating pressure, the sensor will shut the engine OFF to prevent any internal damage to your generator's engine from occurring by interrupting the DC voltage to the ignition coil.

## Engine Oil Change (to include filter)

### 1. Draining the Oil Sump

Discharge the old oil through the sump drain hose (attached at the front of the engine) while the engine is still warm. Drain the old oil completely, replace the hose in its bracket, and replace the end cap securely.

Always observe the old oil as it is removed. A yellow/gray emulsion indicates the presence of water in the oil. Although this condition is rare, it does require prompt attention to prevent serious damage. Call a competent mechanic should water be present in the oil. Raw water present in the oil can be the result of a fault in the exhaust system attached to the engine, and/or water siphoning through the raw water cooling circuit into the exhaust, filling it up into the engine.

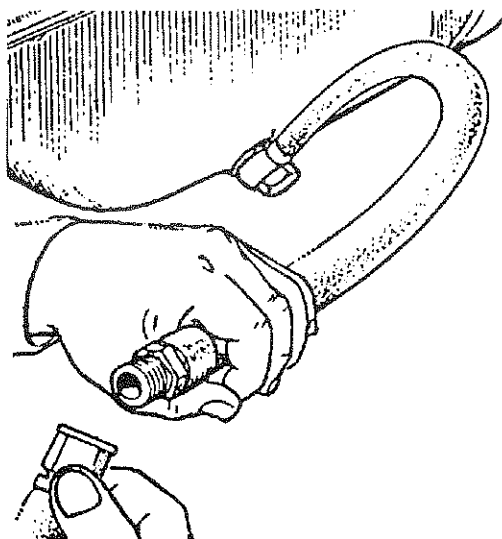

### 2. Replacement of the Oil Filter

When removing the used oil filter, you may find it helpful and cleaner to punch a hole in the upper and lower portion of the old filter to drain the oil into a container before removing it. This helps to lessen spillage. A small style automotive filter wrench should be helpful in removing the old oil filter. Place some paper towels and a plastic bag around the filter when unscrewing it to catch any oil left in the filter. (Oil or any other fluid on the engine reduces the engine's cooling ability. Please keep your generator's engine clean.) Inspect the old oil filter as it is removed to make sure that the rubber sealing gasket came off with the old oil filter. If this rubber sealing gasket remains sealed against the engine block, gently remove it. The replaceable cartridge-type oil filter requires no cleaning inside, so it may be properly disposed of.

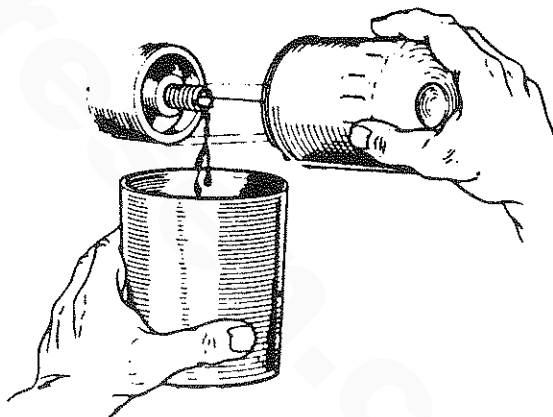

When installing the new oil filter element, wipe the filter gasket's sealing surface on the engine block free of oil and apply a thin coat of clean engine oil to the rubber gasket on the new oil filter. Screw the filter onto the threaded oil filter stub, and then tighten the filter firmly by hand.

**NOTE:** Generic filters are not recommended, as the material standards or diameters of important items on generic parts might be entirely different from genuine parts. Immediately after an oil filter change and oil fill, run the engine to make sure the oil pressure is normal and that there are no oil leaks around the new oil filter.

### 3. Filling the Oil Sump

Add fresh oil through the oil filler cap on the valve cover. After refilling the oil, run the engine for a few moments while checking the engine's oil pressure. Make sure there is no leakage around the new oil filter or from the oil drain system, and stop the engine. Then, check the quantity of oil with the dipstick. Fill to, but not over, the high mark on the dipstick, should the engine require additional oil.

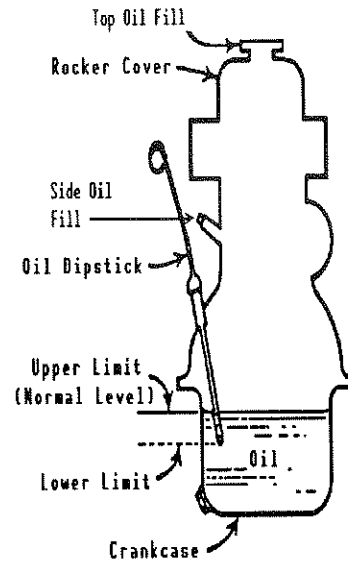

**BC GENERATOR (60 - 50 HERTZ)**

The BC generator is a brushless, self-excited generator which requires only the driving force of the engine to produce an AC output. The stator houses two sets of windings: the main stator windings and the exciter windings. When the generator is started, residual magnetism in the four rotating poles induces a current in the stator exciter windings. This flow of current then induces a greater current flow through the four rotating poles which then generates an even larger current in the exciter windings. This mutual build up of current in the four rotating poles and in the exciter windings quickly reaches the saturation point of the capacitor(s) and a regulated energy field is then maintained in the stator. At the same time, this regulated field produces a steady voltage in the stator windings which can then be drawn off the generator's AC terminals to operate AC equipment.

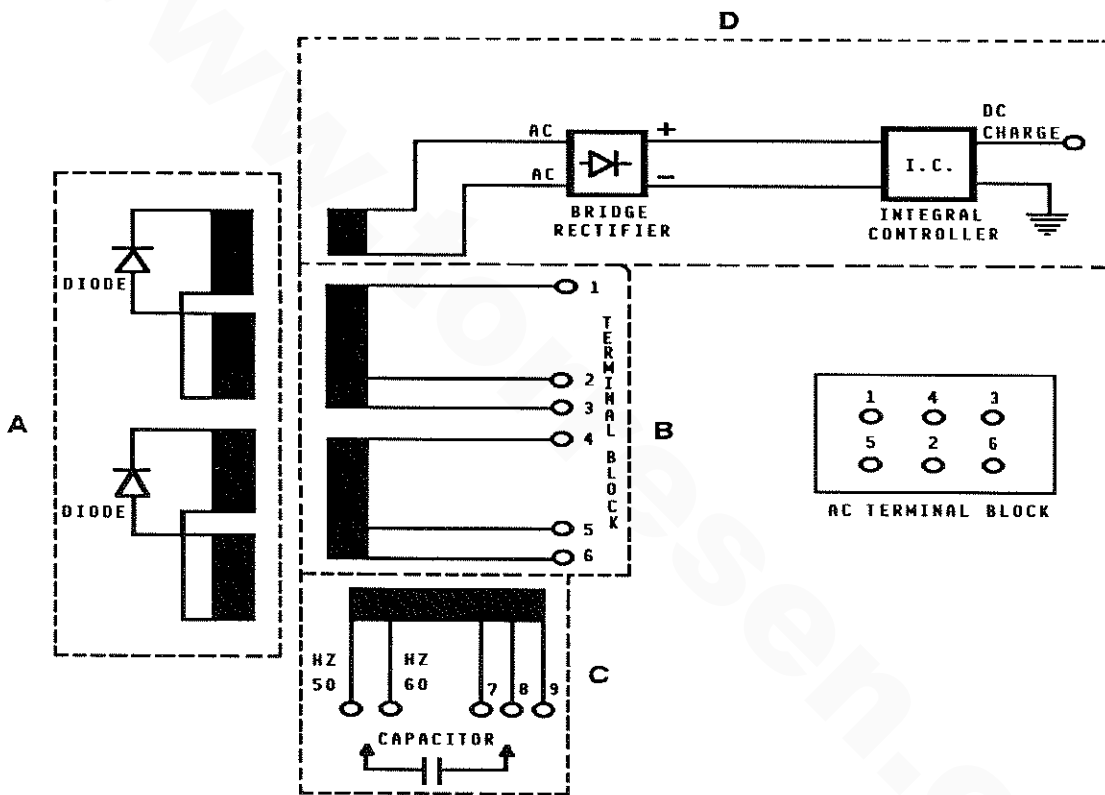

Generator Internal Wiring Schematic with DC Battery Charging Circuit

A. Rotating Field/Auxiliary Windings with Diodes

B. Main Stator Windings

C. Exciter Windings and Capacitor

D. Bridge Rectifier and Integral Controller

**Generator Frequency**

Frequency is a direct result of engine/generator speed: 1800 rpm - 60 hertz, 1500 rpm - 50 hertz. To change the generator's frequency, refer to the "MAINTENANCE AND ADJUSTMENTS" section of this manual.

BCA GENERATOR (60 HERTZ ONLY)

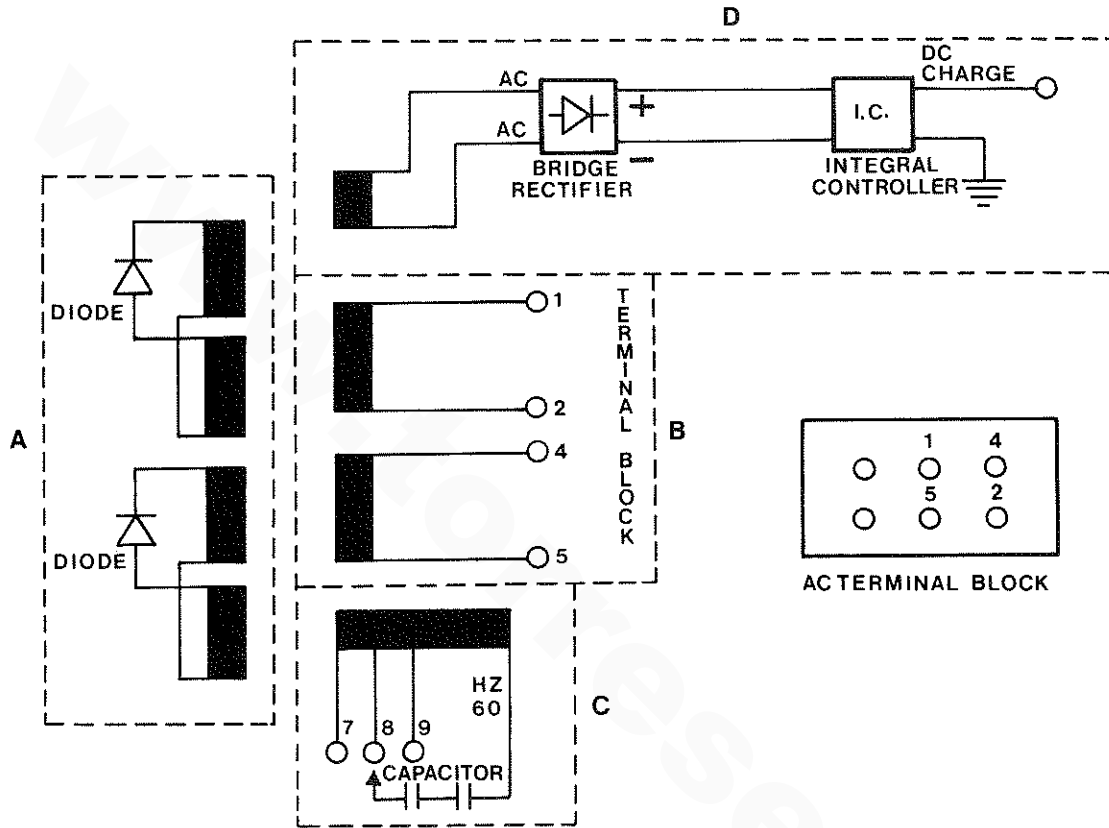

Generator Internal Wiring Schematic with DC Battery Charging Circuit

A. Rotating Field/Auxiliary Windings with Diodes

B. Main Stator Windings

C. Exciter Windings and Capacitor

D. Bridge Rectifier and Integral Controller

### No-Load Voltage Adjustment

1. Remove the louvered metal plate covering the terminal connections and the capacitor.
2. Start the generator and allow it to run for approximately five minutes so the engine can warm up. Make sure the generator is operating without any equipment drawing AC current from the generator (that is, shut OFF all electrical appliances). Make sure the engine's speed (hertz) is correct. Adjust the governor as needed to obtain the correct engine speed before proceeding.
3. Referring to the AC load connections, as illustrated under the "Load Connections" heading for the BC and BCA models, check the generator's no-load voltage by measuring the voltage across the neutral lead and the hot lead with a volt meter. Make sure you record this reading. The generator's no-load voltage is 115 - 128 volts at 60.5 - 61.5 hertz. If the voltage output is higher or lower than specified, proceed.
4. Shut off the generator. Make sure the correct hertz lead for the BC model (60 hertz #6, or 50 hertz #5) is plugged into the capacitor. Refer to the illustration on the top of the next page.

#### **WARNING**

**Do not attempt to make a no-load voltage adjustment while the generator is operating.** The capacitor can hold a 450 - 500 volt charge. Touching any wiring can result in a severe electrical shock. In addition, attempting to make a no-load voltage adjustment while the generator is operating can cause fingers to be caught in the generator's rotor.

5. Refer to the illustrations on the next page before making any adjustments. Note that there are three plugs grouped for the right capacitor terminal, #7, #8, and #9. If the generator's no-load voltage is low, then disconnect the lower numbered plug and connect the plug with the next higher number. If the generator's no-load voltage is high, then disconnect the higher numbered plug and connect the plug with the next lower number. Note that the plug presently connected to this terminal may be any one of the three plugs available.
6. If the generator's no-load voltage cannot be adjusted because the voltage needs to be increased and the highest numbered plug is already connected to the right terminal, or the voltage needs to be lowered and the lowest numbered plug is connected, then follow the steps at the bottom of the next page. Ask your local Westerbeke dealer for a BC GENERAL TROUBLESHOOTING GUIDE before performing the steps listed at the bottom of the next page.

NOTE: Make sure the insulating covers on the unused leads are in place and are not in contact with each other or in contact with the generator's housing.



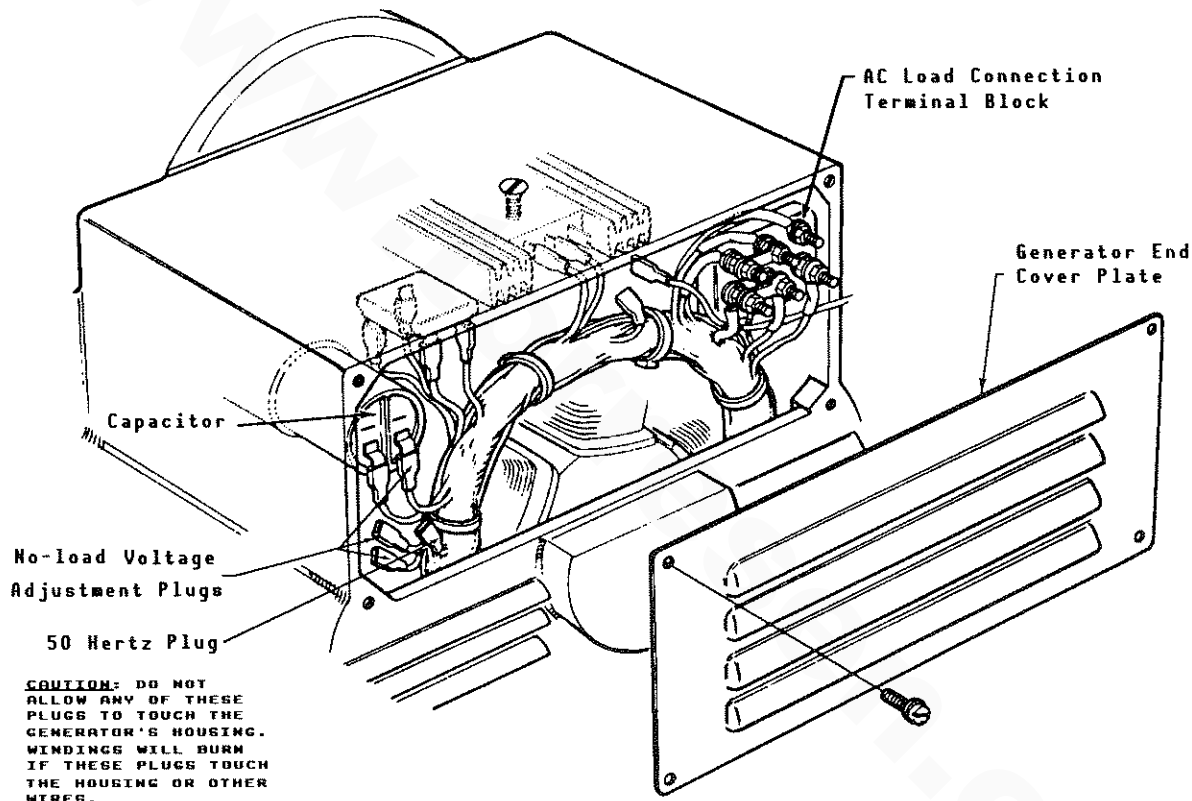
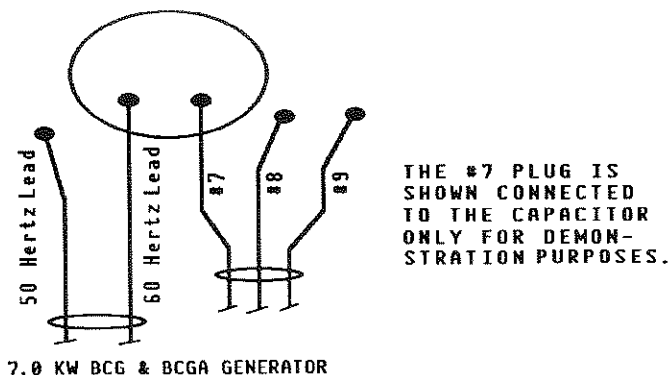

A. Check the resistance of the exciter windings

7.0 KW BCG & BCGA: 1.9 ohm

B. Check the capacitor.

7.0 KW BCG & BCGA: 31.5 uF ± 5°

C. Check the engine's speed.

60 hertz: 60.5 - 61.5

50 hertz: 50.5 - 51.5

Adjust the engine's speed by use of the governor speed adjustment to obtain the correct hertz.

NOTE: Refer to the "NOTE" at the bottom of the next page.

**Load Connections**

The generator's data plate gives the voltage, current and frequency rating of the generator. An AC wiring decal is affixed to the inside of the louvered cover on the generator end. A diagram of the various AC voltage connections is provided on the decal.

The generator is a single-phase, reconnectable 120 volts AC two-wire or 120/240 volts AC three-wire, at 60 hertz; or 110 volts AC two-wire, 110/220 volts AC three-wire, or 220 volts AC two-wire, at 50 hertz. Refer to the "SYSTEM SPECIFICATIONS" section of this manual for the 7.0 KW BCG generator rating.

NOTE: The frame ground wire must be moved when changing from 110 volts, 50 hertz to /220 volts, 50 hertz.

A circuit breaker should be installed between the generator and the AC load. This circuit breaker should be rated at 120% of the generator's AC output and be able to react quickly to overloads, subject to motor starting considerations.

**BC Generator (60 - 50 hertz)**

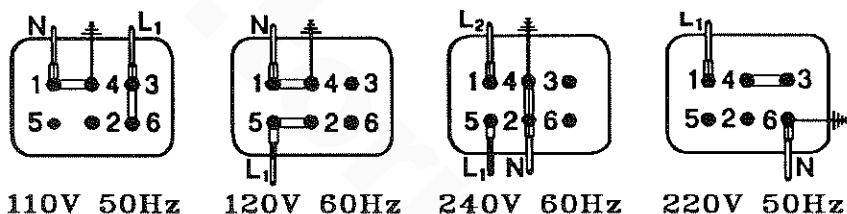

For making connections to the AC terminal block, use terminal ends for #10 studs which will accept multi-strand wire sized for the number of conductors in the bundle, the rating of the conductor's insulation, and amperage that will be drawn through the conductor(s). (Refer to the generator's data plate for the generator's amperage and voltage ratings.)

NOTE: When changing hertz produced by the generator, an engine speed adjustment at the governor must be made. The AC output connections on the above illustrated terminal blocks must be selected for the voltage and hertz to be produced. A plug at the capacitor must be changed for 50 (#5) or 60 (#6) hertz use.

**BCA Generator (60 hertz only)**

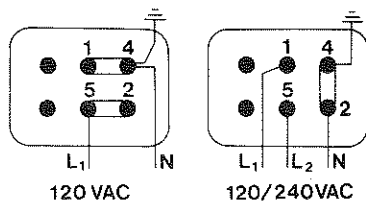

### Shore Power Connections

If the installer connects shore power to the vessel's AC circuit, this must be done by means of the SHORE POWER/OFF/SHIPS GEN., center position-off transfer switch shown below. Use of this switch prevents simultaneous connection of shore power to generator output.

#### CAUTION

Damage to the generator can result if utility shore power and generator output are connected at the same time. This type of generator damage is **not** covered under the warranty; it is the installer's responsibility to make sure all AC connections are correct.

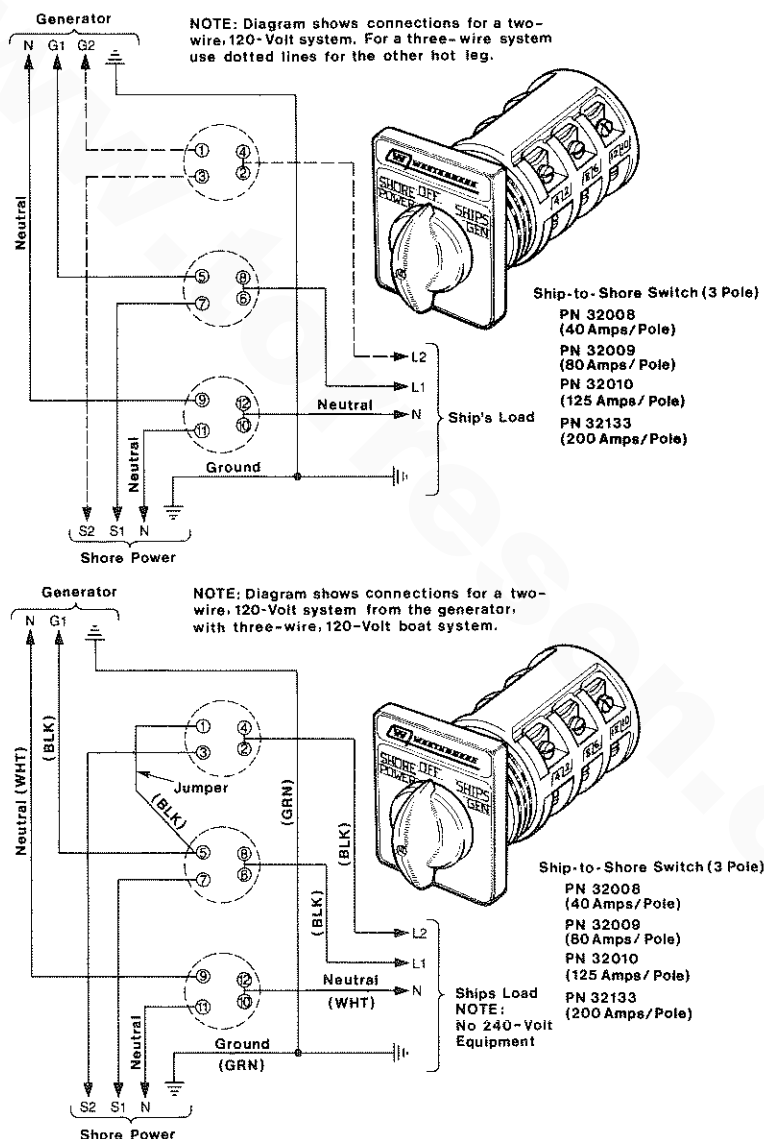

Shore Power Switch Connection Diagrams

Operators are cautioned when switching from shore power to generator power or vice-versa, heavy motor loads should be shut off before switching as voltage surges induced by switching with heavy AC loads on the vessel being operated can/may cause damage to the exciter circuit components in the generator.

**GENERAL INFORMATION AND CARE OF THE GENERATOR**

**Use of Electric Motors**

The power required to start an electric motor is considerably more than is required to keep it running after it is started. Some motors require much more current to start than others. Split-phase (AC) motors require more current to start, under similar circumstances, than other types. These motors are commonly used on easy-starting loads, such as washing machines, or where loads are applied after the motor is started, such as small power tools. Because they require 5 to 7 times as much current to start as to run, their use should be avoided, whenever possible, if the electric motor is to be driven by a small generator. Capacitor and repulsion-induction motors require from 2 to 4 times as much current to start as to run. The current required to start any motor varies with the load connected to it. An electric motor connected to an air compressor, for example, will require more current than a motor to which no load is connected.

In general, the current required to start 120-volt motors connected to medium starting loads will be approximately as follows:

MOTOR SIZE (HP)	AMPS FOR RUNNING (Amperes)	AMPS FOR STARTING (Amperes)
1/6	3.2	6.4 to 22.4*
1/4	4.6	9.2 to 32.2*
1/3	5.2	10.4 to 72.8*
1/2	7.2	14.4 to 29.2
3/4	10.2	20.4 to 40.8
1	13	26 to 52

\* Note that in the above table the maximum "Amps for Starting" is more for some small motors than for larger ones. The reason for this is that the hardest starting types (split-phase) are not made in larger sizes.

Because the heavy surge of current needed for starting motors is required for only an instant, the generator will not be damaged if it can bring the motor up to speed in a few seconds. If difficulty is experienced in starting motors, turn off all other electrical loads and, if possible, reduce the load on the electric motor.

**Required Operating Speed**

Although individual units may vary slightly, the normal voltage and frequency of typical 60(50)hertz engine-driven generators described in this manual are shown on the chart on the next page.

Run the generator at first with no-load applied, then at half the generator's capacity, and finally loaded to its full capacity as indicated on the generator's data plate.

See the rpm/hertz/frequency chart on the next page.

Load Applied	4-Pole Speed (rpm)	Frequency (Hertz)	Generator 120V (110) Plants	Voltage 240V (220) Plants
None	1830 (1530)	62 (52)	122 (112)	240 (224)
Half	1800 (1500)	60 (50)	120 (110)	240 (220)
Full	1755 (1455)	59 (49)	110 (100)	220 (200)

The output voltage should be checked periodically to ensure proper operation of the generating plant and the appliances it supplies.

If an AC voltmeter or ampmeter is not installed to monitor voltage and load, check it with a portable meter and amp-probe.

#### Preventive Maintenance (Generator)

Maintenance on the generator is minimal.

1. Keep the generator **clean, dry and well-ventilated**.
2. Make sure all connections are clean and tight and that cables carrying AC voltage are properly supported and protected against chafing.
3. The rear armature bearing is lubricated and sealed; therefore, no maintenance is required. If the bearing becomes rough or noisy, replace it.

#### Generator Troubleshooting

A complete and illustrated text on troubleshooting the BC series of generators is furnished in booklet form and incorporated in the Technical Manual which is available through your local dealer.

## ENGINE TROUBLESHOOTING

### Introduction

The tables which follow indicate troubleshooting procedures based upon certain problem indicators, the probable causes of the problems, and the recommendations to overcome these problems.

Note that the engine's control system (electrical system) is protected by a 20-Ampere manual reset circuit breaker located next to the starter motor and the (-) ground terminal. Refer to the model photographs at the beginning of this manual for a photograph showing the exact position of this reset circuit breaker.

<u>Trouble</u>	<u>Possible Cause</u>
Engine cranks but fails to start.	<ol style="list-style-type: none"> <li>1. Out of fuel.</li> <li>2. Engine is flooded.</li> <li>3. Filters are clogged by contaminated fuel.</li> <li>4. Voltage drop at (+) at overspeed switch.</li> <li>5. Worn or faulty spark plugs.</li> <li>6. Bad ignition coil.</li> <li>7. High-tension leads grounding (wet system).</li> <li>8. Automatic shutdown switch is faulty.</li> <li>9. Fuel pump inoperative.</li> <li>10. Filter in carburetor is clogged.</li> <li>11. Tripped overspeed switch (reset and start).</li> <li>12. Faulty choke solenoid.</li> <li>13. Faulty fuel solenoid on carburetor.</li> </ol>
Engine does not crank.	<ol style="list-style-type: none"> <li>1. Battery is low or dead.</li> <li>2. Engine's DC 20-Amp breaker has tripped.</li> <li>3. Raw water filled cylinders. (Remove spark plugs.)</li> <li>4. Loose battery connections.</li> <li>5. Voltage drop at starter solenoid terminal.</li> </ol>

<u>Trouble</u>	<u>Possible Cause</u>
	<ol style="list-style-type: none"><li>6. Bad starter solenoid.</li><li>7. Faulty START switch.</li></ol>
Engine starts, runs and then shuts down.	<ol style="list-style-type: none"><li>1. Faulty automatic shutdown switch (oil, water, or exhaust).</li><li>2. Faulty overspeed switch (reset and start; bypass switch to test).</li><li>3. Faulty fuel pump.</li><li>4. Faulty STOP switch.</li><li>5. Engine circuit breaker is tripping.</li><li>6. Dirty fuel filters.</li><li>7. Low oil level in sump.</li><li>8. Mechanical check valve at the fuel supply fuel pump is unable to draw fuel through this valve creating fuel starvation.</li></ol>
Back firing through carburetor.	<ol style="list-style-type: none"><li>1. Ignition timing is wrong.</li><li>2. Engine is flooded.</li><li>3. Choke is stuck closed.</li><li>4. Spark plug wires are connected wrong- check firing order.</li><li>5. Distributor cap is cracked.</li><li>6. Dirty air cleaner.</li></ol>
Engine overheats.	<ol style="list-style-type: none"><li>1. Coolant loss (pressure test the cooling system).</li><li>2. Belts are loose or broken.</li><li>3. Raw water pump's impeller is faulty.</li><li>4. Raw water pump is worn.</li></ol>

Trouble

Possible Cause

5. Faulty hose.
6. Thermostat is stuck closed.
7. Heat exchanger is clogged.
8. Faulty gauge (check coolant temperature with a thermometer).

---

Engine hunts.

1. Throttle linkage is binding.
2. Fuel starvation.
3. Dirty fuel filters.
4. Defective fuel pump.
5. Governor is out of adjustment.
6. Valves are out of adjustment.
7. Generator is overloaded.
8. Cracked distributor.
9. Faulty high-tension leads.

---

Engine misfires.

1. Ignition timing is wrong.
2. Spark plugs are worn.
3. Valve clearances are incorrect.
4. Dirty carburetor.
5. Dirty air cleaner.
6. Poor quality fuel.

---

High oil pressure.

1. Faulty gauge.
2. Relief valve is stuck.
3. Dirty oil or wrong SAE type oil in the engine.



<u>Trouble</u>	<u>Possible Cause</u>
Low oil pressure.	<ol style="list-style-type: none"><li>1. Low oil level.</li><li>2. Faulty gauge.</li><li>3. Wrong SAE type oil in the engine.</li><li>4. Wrong type oil filter.</li><li>5. Relief valve is stuck.</li><li>6. Faulty oil pump.</li></ol>
No DC charge to the starting battery.	<ol style="list-style-type: none"><li>1. DC connections to the controller are loose or faulty.</li><li>2. Faulty controller circuit component.</li></ol>
Black exhaust smoke is discharged from the engine.	<ol style="list-style-type: none"><li>1. Dirty air intake.</li><li>2. Choke is stuck closed.</li><li>3. Carburetor is flooding.</li></ol>
Blue exhaust smoke is discharged from the exhaust.	<ol style="list-style-type: none"><li>1. Valves are worn or adjusted incorrectly.</li><li>2. Piston rings are worn or unseated.</li><li>3. Lubrication oil is diluted.</li><li>4. Crankcase breather hose is clogged.</li></ol>

## MAINTENANCE AND ADJUSTMENTS

### Introduction

This section contains a scheduled preventive maintenance program and several adjustment procedures the owner/operator can perform without the benefit of sophisticated and expensive tools and instruments.

### Preventive Maintenance (Engine)

Perform the preventive maintenance in accordance with the schedules listed in the following paragraphs. Adherence to these schedules will make sure the equipment is maintained in the best possible condition and that it will perform to expectations. Those items marked by an asterisk (\*) are recommended to be performed by an authorized dealer or distributor.

### Daily (before each use)

1. Check the oil sump level. Maintain the oil level at or near the upper level mark on dipstick.
2. Check the coolant level in the plastic recovery tank. Maintain the coolant level halfway between the **MAX** and **ADD** marks.
3. Visually inspect the unit; check for loose belts, chafed or broken wires, loose brackets and fittings, damaged hoses, loose clamps, and other equipment not properly secured.
4. Check the fuel supply. Fill the tank(s) with a good grade of unleaded or leaded gasoline that has an octane rating of 89 or higher.
5. Check the primary filter/water separator. Drain and service this filter as required. (A primary filter/water separator is optional, but strongly recommended.)
6. If an optional instrument panel is installed, check the engine's gauges for proper oil pressure, operating temperature, and starting battery charging voltage once the engine is operating.
7. If AC gauges are installed, check the generator's output meters for proper AC voltage and output frequency.

### Monthly

Check the condition of the zinc anode in the heat exchanger's raw water circuit. Clean or replace the anode, as required. Keep the area inside the heat exchanger clean of zinc anode debris.

### Servicing After Initial 50 Hours of Operation

1. Change the engine's lubrication oil and oil filter.
2. Clean or replace the fuel filter screen in the carburetor and in the primary fuel filter/water separator.

- \*3. Retorque the cylinder head hold down bolts.
- \*4. Adjust valve clearances.
- 5. Adjust Governor/Fresh Water Pump and Raw Water Pump drive belt tension, if required.
- 6. Adjust the engine's no-load speed, if required (hertz). Please note that this adjustment is **not** a warrantable adjustment during or after the unit's break-in.
- \*7. Check ignition point gap and engine timing. (Check condition of distributor cap rotor.)

#### **Servicing After Every 100 Hours of Operation**

- 1. Change the engine's lubrication oil and oil filter.
- 2. Adjust the water pump drive belt tension, if required.

#### **Servicing After Every 250 Hours of Operation**

Clean or replace the fuel filter element in the carburetor.

#### **Servicing After Every 500 Hours of Operation**

- \*1. Adjust the valve clearances.
- 3. Drain, flush, and refill the fresh water cooling system
- \*4. Check the condition of the starter motor drive pinion; lubricate pinion.
- 5. Check the outside of the engine. Make sure any oil on the engine's surface is cleaned. Any dirt or oil on the engine inhibits the engine's ability to cool. Please keep the engine clean.
- 6. Check the raw water pump for internal wear. Examine the pump's cover, cam, and internal housing. Replace worn parts as needed. Check for leaks and repair them as needed.
- 7. Check spark plug gap, ignition point gap and ignition timing.
- 8. Inspect plug wires, distributor cap and rotor.
- 9. Change governor lube oil.
- 10. Check the internal condition of the water injected exhaust elbow. Inspect exhaust and water passages. Remove any carbon and/or corrosion build up.

#### **Servicing After Every 800 Hours of Operation**

- \*Check the tightness of bolts, nuts, and clamps.

### Servicing After Every 1000 Hours of Operation

Remove, clean, and pressure test the primary heat exchanger. (A local automotive radiator shop should be able to clean and test the heat exchanger.)

NOTE: Operating in silty and/or tropical waters may require that a heat exchanger cleaning be performed more often than every 1000 hours.

### Generator Frequency Adjustment

Frequency is a direct result of engine/generator speed, as indicated by the following:

When the generator is run at 1800 rpm, the AC voltage output frequency is 60 hertz. When the generator is run at 1500 rpm, the AC voltage output frequency is 50 hertz.

Therefore, to change the generator's frequency, the generator's speed *must* be changed. To accomplish the frequency change, connect the AC output leads to the AC terminal block in accordance with the "AC Voltage Connections" diagram specified for your generator set, which appears in the "BC GENERATOR" section of this manual.

### Ignition Timing

1. Attach a timing light to the #1 spark plug and mark the front timing pointer to indicate 10°. Locate the timing mark on the crankshaft pulley and mark it with white chalk or crayon.
2. Start the engine and warm it up to its normal operating temperature. Make sure the generator is operating without a load on it.
3. Using the timing light, align the timing mark in the front crankshaft pulley so it is just slightly before the 10° mark of the timing pointer. Do this by loosening and slowly rotating the distributor body. Refer to the timing specifications below.

Timing Specifications:

7.0 KW BCG & BCGA

10° ± .5° BTDC at 1800 rpm

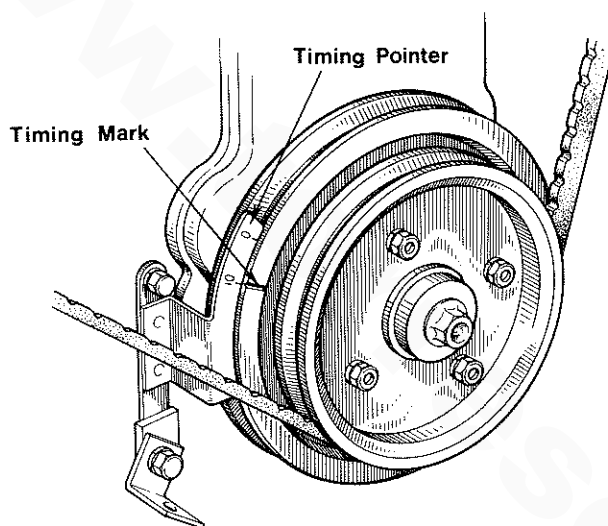

### Choke Solenoid

The choke solenoid is a 12 volt DC operated unit that functions to close the choke plate in the carburetor when the START switch is depressed during engine start up.

The choke solenoid de-energizes once the engine starts and the START switch is released. Some unstable running may be present when the engine starts cold but should smooth out as the engine reaches operating temperature.

Keep this solenoid dry and periodically lubricate the linkage between the solenoid and the choke lever.

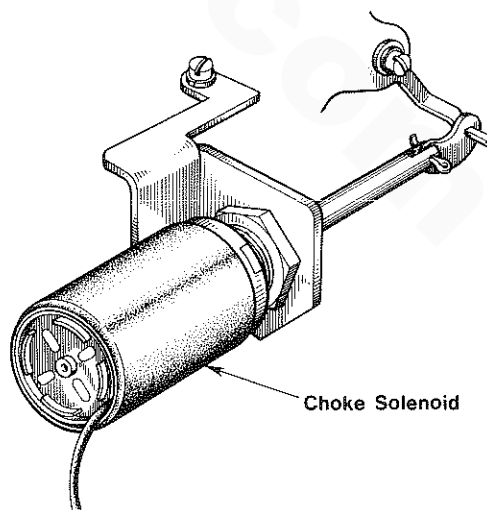

## Governor Adjustments

Operate the generator set to bring the unit up to its operating temperature before attempting an adjustment.

**NOTE:** If the governor is severely out of adjustment, manually adjust the linkage without any load on the generator to obtain a safe output voltage before proceeding with the adjustment.

Three adjusting points are on the governor. (Refer to the illustration below.)

7.0 KW BCG & BCGA Governor

1. **Bumper Screw** This screw is used to remove a no-load surge **only**. **Never** turn the bumper screw into the governor far enough so that it increases the no-load speed. To adjust the governor, turn the bumper screw in until the engine stops surging. Now bring the Increase/Decrease Speed Screw (on the governor) up until the generator runs between 60.5 to 61.5 cycles no-load. Apply a 1/4, a 1/2 and a 3/4 load to the generator and ensure the generator does not surge under these three load intervals.

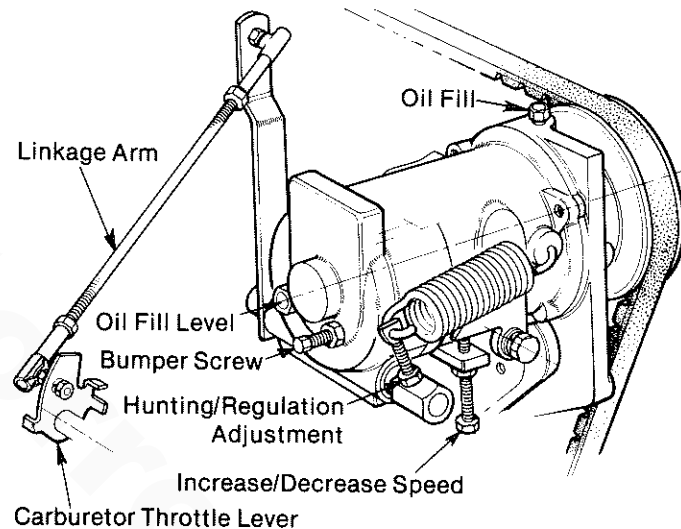

**NOTE:** Only if the generator surges at any of these load intervals are you to follow steps #2 and #3 below.

2. **Increase/Decrease Speed** This adjusting bolt sets the no-load speed of the engine. (The linkage arm between the governor arm and throttle lever should be adjusted to hold the throttle full open when the engine is not running.) Make sure this linkage moves freely and that the ball joint connectors are properly lubricated. Use graphite lubricant at this connection. Disconnect the ball joint and apply a graphite lubricant to the inside of the joint.
3. **Hunting/Regulation** If the variation in engine speed between no-load and full-load is too great, adjust this eye bolt to draw the spring closer to the lever hub. The increase/decrease speed bolt may need to be adjusted as well.

If the governor surges while under a load, adjust this eye bolt to move the spring away from the lever hub. (Check the speed adjustment.)

## Governor Maintenance

1. Periodically lubricate the attaching points at both ends of the linkage arm. Use a graphite lubricant or an equivalent.

**NOTE:** Free movement of this linkage arm is important for proper governor/throttle operation.

2. Governor oil capacity: 7.0 KW BCG & BCGA is 1.5 ounces of SAE #10/30 motor oil.

NOTE: Do not overfill the governor.

3. Change the governor's oil every 500 hours of operation.

4. The drive belt should be maintained in good condition. Replace the belt if it becomes worn or shows signs of cracking. (Keep a spare on hand for unexpected needs.)

To change the oil, remove the governor from engine and remove the oil fill and fill level plug and drain all the oil from the governor. Reinstall the governor on the engine and fill it with the proper quantity of SAE 10/30 engine oil, and replace the plugs.

### Carburetor Adjustment

#### 1. Idle Mixture Jet

Disconnect the throttle linkage arm from the governor control arm and reduce the engine's speed with the idle stop screw. Turn the idle mixture screw clockwise (in) until the engine skips; back the screw out (counterclockwise) slowly until the engine smooths then skips again; then turn the screw clockwise (in) 1/4 to 1/2 of a turn. The idle mixture should be satisfactory at this setting.

#### 2. Run Mixture Jet

This mixture jet is pre-sized at the factory and is **not** adjustable. An adjustment to the idle jet screw, while the unit is operating at 1800 rpm, will have an affect on the unit's performance. Refer to the "Governor Adjustments" section of this manual for instructions on how to adjust the engine's speed.

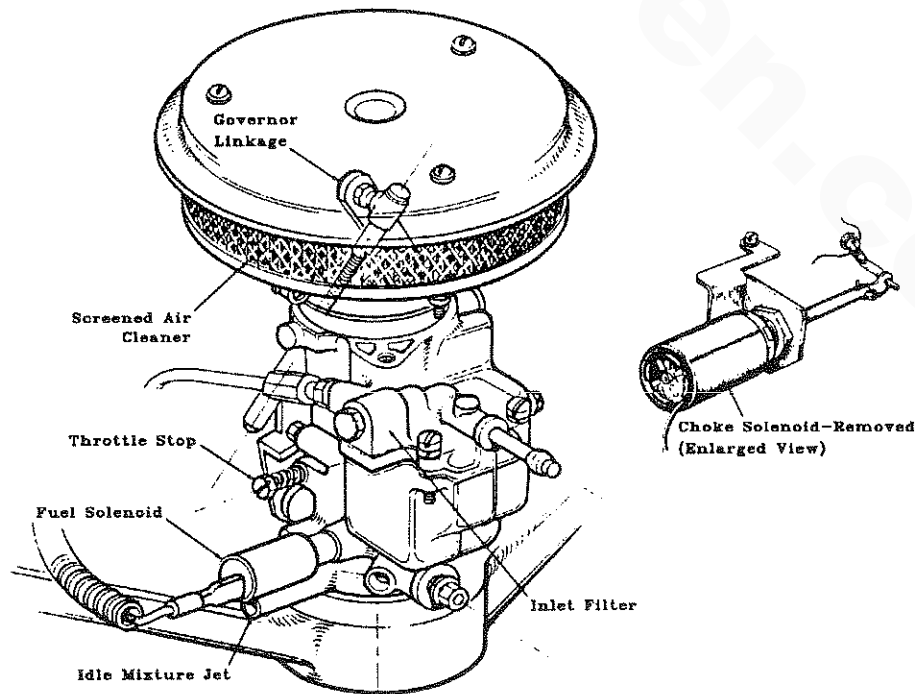

### Torquing Cylinder Head Bolts

Tighten the cylinder head bolts according to the sequence shown in the illustration below. Make sure the engine is cold when this is done. Loosen one head bolt one-half turn and then tighten it to the specified torque. Then proceed to the next head bolt in the sequence numbering shown.

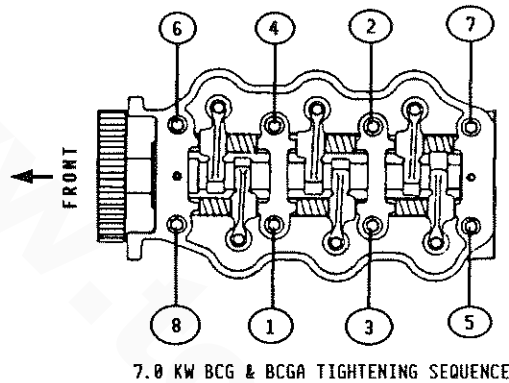

### Torque Specifications:

7.0 KW BCG & BCGA

36.2 - 43.4 lb-ft (5.0 - 6.0 kg-m)



### Valve Clearance Adjustment

NOTE: Retorque the cylinder head bolts before adjusting the engine's valves.

1. Remove the rocker cover and the gasket.
2. Carry out the check and adjustment of valve clearances, with the piston of the No.1 cylinder positioned at the top of its compression stroke and the exhaust and intake valves completely closed. See #2 of the table to the right below for the values to be adjusted in this position.
3. Rotate the crankshaft 180° to position the No.1 piston at the top of its exhaust stroke. Adjust the values as indicated in #3 of the table to the right below.
4. Replace the rocker cover along with a new rocker cover gasket.

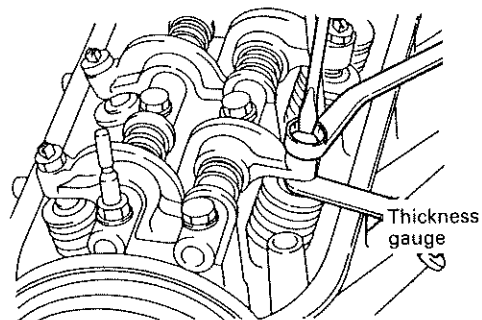

Rocker cover torque: 2.9 - 5.1 lb-ft (0.4 - 0.7 kg-m)

CRANK ANGLE		CYLINDER		
		1	2	3
#2	When No.1 piston is set at end of compression stroke, adjust the valves.	IN	•	•
		EX	•	•
#3	When No.1 piston is positioned at the top of exhaust stroke, adjust the valves.	IN	•	
		EX		•

### Spark Plugs

To service the spark plugs, clean, gap or replace the plugs as needed.

**WARNING**

Do not remove the spark plugs while the engine is hot. Allow the engine to cool before removing the spark plugs.

Spark plug gap: 0.028 - 0.031 inches  
(0.7 - 0.8 mm)

Spark plug torque:  
7.0 KW BCG & BCGA 10.8 - 15.2 lb-ft  
(1.5 - 2.1 kg-m)

Check each plug for damage and/or wear.

NOTE: Loc-tite "Anti-Seize" applied to the threaded portion of the spark plugs will retard corrosion, making future removal of the spark plugs easier.

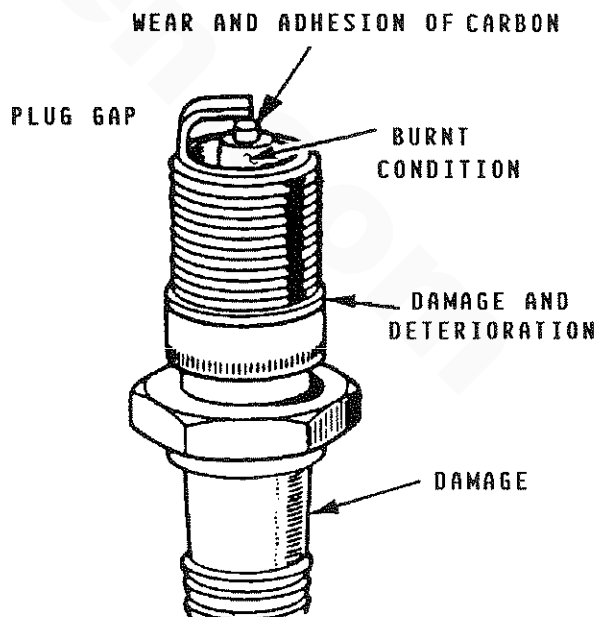

## LAY-UP AND RECOMMISSIONING

### General

Many owners rely on their boatyards to prepare their craft, including engines and generators, for lay-up during the off-season or for long periods of inactivity. Others prefer to accomplish lay-up preparation themselves.

The procedures which follow will allow you to perform your own lay-up and recommissioning, or to use as a check list if others do the procedures. These procedures should afford your engine protection during a lay-up and also help familiarize you with the maintenance needs of your engine. If you have any questions regarding lay-up procedures, call your local servicing dealer; he will be more than willing to provide assistance.

### Fresh Water Cooling System

A 50-50 solution of antifreeze and fresh water is recommended for use in the fresh water cooling system at all times. This solution may require a higher concentration of antifreeze, depending on the area's winter climate. Check the solution in the manifold to make sure the antifreeze protection is adequate.

Should more antifreeze be needed, drain an appropriate amount from the engine block and add a more concentrated mixture. Operate the engine to ensure a complete circulation and mixture of the antifreeze concentration throughout the cooling system. Now recheck the antifreeze solution's strength in the manifold.

### Lubrication System

With the engine warm, drain all the lubricating oil from the oil sump. Remove and replace the oil filter. (Place some paper towels and a plastic bag around the filter to catch the oil during its removal.)

When installing the new oil filter, be sure to apply a small amount of oil on the rubber sealing gasket at the base of the filter. Fill the sump with the correct amount of oil for your engine model. Use an oil with an API specification of SE, SF or SG. Run the engine and check for proper oil pressure and make sure there are no leaks.

### CAUTION

**Do not** leave the engine's old lubricating oil in the sump over the lay-up period. Lubricating oil and combustion deposits combine to produce harmful chemicals which can reduce the life of your engine's internal parts.

### Fuel System

Top off your fuel tanks with regular or unleaded gasoline with an octane rating of 89 or higher. Fuel additives should be added at this time to control algae and condition the fuel. Care should be taken that the additives used are compatible with the primary filter/water separator used in the system. Change the element in your primary fuel filter/water separator, the fuel system should contain one, and clean the separator sediment bowl. Clean the filter screen at the inlet to the carburetor.

### Raw Water Circuit

Close the through-hull sea cock. Remove the raw water intake hose from the sea cock. Place the end of this hose into a 5-gallon bucket of clean fresh water. Before starting the engine, check the zinc anode found in the primary heat exchanger on the engine and clean or replace it as required. Clean the raw water strainer, if one is installed, in the inside of the hull.

Start the engine and allow the raw water pump to draw fresh water through the system. When the bucket is empty, stop the engine and refill the bucket with an antifreeze solution slightly stronger than needed for winter freeze protection in your area.

Start the engine and allow all of this mixture to be drawn through the raw water system. Once the bucket is empty, stop the engine. This antifreeze mixture should protect the raw water circuit from freezing during the winter lay-up, as well as providing corrosion protection.

Remove the impeller from your raw water pump (some antifreeze mixture will accompany it, so catch it in a bucket). Examine the impeller. Acquire a replacement, if needed, and a cover gasket. **Do not** replace the impeller (into the pump) until recommissioning, but replace the cover and gasket. See the "Cylinder Lubrication" section below.

### Intake Manifold and Through-Hull Exhaust

The flame arrester on the carburetor is removed to fog the engine. **Do not** reinstall it. Place a cloth sprayed with fogging oil into the intake of the carburetor. Close off the exhaust outlet of the transom in the same manner. Be sure to remove both cloths and reinstall the flame arrester prior to start-up.

### Starter Motor

Lubrication and cleaning of the starter drive pinion is advisable, if access to the starter permits its easy removal. Make sure the battery connections are shut off before attempting to remove the starter. Take care in properly replacing any electrical connections removed from the starter.

### Cylinder Lubrication

Fogging the engine should be done as the last of the antifreeze mixture is drawn into the raw water circuit. Remove the air intake screen (the air filter) and spray Marvel Mystery Oil or another commercially available fogging oil into the carburetor while the engine is running. Spray enough oil to stall the engine. This will coat the walls of the cylinders, pistons, and valve surfaces with this protective oil. Remove the spark plugs and spray a small amount of this oil into each spark plug hole and turn the engine over two or three complete revolutions by hand. Reinstall, but do not tighten, the spark plugs, as these will need to be cleaned and gapped prior to recommissioning. Close off the carburetor's air filter with an oily rag.

### Spares

Lay-up time provides a good opportunity to inspect the equipment to see if external items such as drive belts or coolant hoses need replacement. Check your basic spares kit and order items not on hand, or replace those items used during the lay-up, such as filters and zinc anodes. Refer to the "SPARE PARTS" section of this manual.

## Batteries

If batteries are to be left on board during the lay-up period, make sure they are fully charged, and will remain that way, to prevent them from freezing. If there exists any doubt that the batteries will remain fully charged or that they will be subjected to severe environmental conditions, remove the batteries and store them in a warmer, more compatible environment.

## Recommissioning

The recommissioning of your Westerbeke unit after a seasonal lay-up generally follows the same procedures as those presented in the "PREPARATIONS FOR STARTING" section regarding preparation for starting and normal starts. However, some of the lay-up procedures will need to be counteracted before starting the engine.

1. Remove the oil-soaked cloths from the intake manifold and from the through-hull exhaust port.
2. Remove the raw water pump cover and gasket. Discard the gasket. Install the raw water pump impeller removed during lay-up (or a replacement, if required). Install the raw water pump cover with a new cover gasket.

### WARNING

**Wear rubber gloves, a rubber apron, and eye protection when servicing batteries.** Lead acid batteries emit hydrogen, a highly-explosive gas, which can be ignited by electrical arcing or a lighted cigarette, cigar, or pipe. **Do not** smoke or allow an open flame near the battery being serviced. Shut off all electrical equipment in the vicinity to prevent electrical arcing during servicing.

3. Reinstall the batteries that were removed during the lay-up, and reconnect the battery cables, making sure the terminals are clean and that the connections are tight. Check to make sure the batteries are fully-charged.
4. Check the condition of the zinc anode in the raw water circuit and clean or replace the anode as needed. Note that it is not necessary to flush the antifreeze/fresh water solution from the raw water coolant system. When the unit is put into operation, the system will self-flush in a short period of time with no adverse effects.
5. Start the unit in accordance with those procedures found in the "STARTING PROCEDURE" section of this manual.

### SPARE PARTS LIST

Since a possibility exists in which the engine may need to be serviced at sea or while in a port other than your home port, certain spare parts should be kept on board to help minimize delays in your voyage. Please refer to your engine's Parts List for part numbers when ordering spare parts. Listed below are those spare parts that should be carried on board at all times.

1. A Raw Water Pump Impeller Kit.
2. A Filter Screen for the Inlet to the Carburetor.
3. A Raw Water Pump/Fresh Water Pump/Governor - Drive Belt.
4. Hose Clamps.
5. A Spare Oil Filter with a Spare Quart of Engine Oil and a Gallon of Premixed Antifreeze.
6. Spark Plugs, Ignition Wires, Distributor Cap, Rotor and Points.
7. Control Panel Fuses.
8. Zinc Anode with Heat Exchanger End Gasket.

Other parts, whose life expectancy cannot be accurately predetermined, should be carried on board (in addition to those listed above) especially if the vessel is to be taken on long ocean voyages. These parts are listed below.

1. Cooling System Hoses.
2. A Starter.
3. A 20 Amp DC Circuit Breaker.
4. An Electric Fuel Pump.
5. A Raw Water Pump or major repair kit.
6. Battery Terminal Connectors.
7. Carburetor Fuel Solenoid.
8. Oil Pressure Switch/Water Temperature Switch/Exhaust Temperature Switch.
9. Overspeed Switch.

The spare parts listed directly above are those we *recommend* be carried on board during long ocean voyages. You may wish to ask other boat owners who have similar crafts and who have completed long ocean voyages as to what spare parts they carried on board and what parts were needed at specific times of the voyage. From the list provided directly above and from these inquiries, you can determine what spare parts may be needed. In addition, if you are planning a long ocean voyage, consult your local Westerbeke dealer for a listing of the Westerbeke dealers located on your route.

**TABLE OF STANDARD HARDWARE TIGHTENING TORQUES**

Unless stated otherwise for a specific assembly, use the following torque values when tightening standard hardware.

	Pitch	lb-ft	kg-m
<u>Grade 4T</u>			
6mm bolt head/nut	1	2.9 - 5.1	0.4 - 0.7
8mm bolt head/nut	1.25	7.2 - 11.6	1.0 - 1.6
10mm bolt head/nut	1.25	13.7 - 22.4	1.9 - 3.1
10mm bolt head/nut	1.5	13.0 - 21.7	1.8 - 3.0
12mm bolt head/nut	1.25 (ISO)	25.3 - 39.8	3.5 - 5.5
12mm bolt head/nut	1.5	25.3 - 39.8	3.5 - 5.5
12mm bolt head/nut	1.75	21.7 - 36.2	3.0 - 5.0
13mm bolt head/nut	1.5	32.5 - 50.6	4.5 - 7.0
14mm bolt head/nut	1.5	36.2 - 57.9	5.0 - 8.0
14mm bolt head/nut	2	34.0 - 55.7	4.7 - 7.7
16mm bolt head/nut	1.5	54.2 - 79.6	7.5 - 11.0
16mm bolt head/nut	2	51.4 - 76.7	7.1 - 10.6

<u>Grade 6T</u>			
6mm bolt head/nut	1	4.3 - 6.5	0.6 - 0.9
8mm bolt head/nut	1.25	10.8 - 15.9	1.5 - 2.2
10mm bolt head/nut	1.25	21.7 - 32.5	3.0 - 4.5
10mm bolt head/nut	1.5	19.5 - 30.4	2.7 - 4.2
12mm bolt head/nut	1.25 (ISO)	36.2 - 57.9	5.0 - 8.0
12mm bolt head/nut	1.5	36.2 - 50.6	5.0 - 7.0
12mm bolt head/nut	1.75	34.7 - 49.2	4.8 - 6.8

<u>Grade 7T, 8T and 8.8</u>			
6mm bolt head/nut	1	5.8 - 8.7	0.8 - 1.2
8mm bolt head/nut	1.25	14.5 - 21.7	2.0 - 3.0
10mm bolt head/nut	1.25	28.9 - 39.8	4.0 - 5.5
10mm bolt head/nut	1.5	26.8 - 37.6	3.7 - 5.2
12mm bolt head/nut	1.25 (ISO)	54.2 - 75.9	7.5 - 10.5
12mm bolt head/nut	1.5	50.6 - 65.1	7.0 - 9.0
12mm bolt head/nut	1.75	43.4 - 61.5	6.0 - 8.5
13mm bolt head/nut	1.5	57.9 - 86.8	8.0 - 12.0
14mm bolt head/nut	1.5	72.3 - 108.5	10.0 - 15.0
14mm bolt head/nut	2	68.7 - 101.3	9.5 - 14.0
16mm bolt head/nut	1.5	108.5 - 166.4	15.0 - 23.0
16mm bolt head/nut	2	101.3 - 159.1	14.0 - 22.0

<u>Grade 5 capscrew</u>			
1/4 UNC		9 - 11	1.2 - 1.5
1/4 UNF		11 - 13	1.5 - 1.8
5/16 UNC		18 - 20	2.5 - 2.8
5/16 UNF		21 - 23	2.9 - 3.2
3/8 UNC		28 - 33	3.7 - 4.6
3/8 UNF		30 - 35	4.1 - 4.8
7/16 UNC		44 - 49	6.1 - 6.8
7/16 UNF		50 - 55	6.9 - 7.6
1/2 UNC		68 - 73	9.4 - 10.1
1/2 UNF		73 - 80	10.1 - 11.1

**TABLE OF TIGHTENING TORQUES**

	<u>lb-ft</u>	<u>kg-m</u>
Cylinder Head Bolts*	36.2 - 43.4	5.0 - 6.0
(*See the Torquing Cylinder Head Bolts section.)		
Crankshaft pulley to crankshaft	36.2 - 43.4	5.0 - 6.0
Rocker cover to cylinder block	2.9 - 5.1	0.4 - 0.7
Spark plug to cylinder head	10.8 - 15.2	1.5 - 2.1
Timing belt cover #1	3.2 - 4.8	0.44 - 0.66
Timing belt cover #2	5.2 - 7.8	0.72 - 1.08
Timing belt tensioner	23.1 - 34.7	3.2 - 4.8
Valve adjusting screws	9.4 - 13.0	1.3 - 1.8
Oil pan drain plug and oil pan	25.3 - 32.5	3.5 - 4.5
Flywheel bolts	28.9 - 36.2	4.0 - 5.0
Exhaust manifold	8.4 - 12.6	1.16 - 1.74
Intake manifold	7.5 - 10.8	1.04 - 1.56

INDEX

**A**

AC Output, Generator ..... 23  
 Automatic Shutdown..... 23

**B**

Batteries..... 23 & 73  
 Battery Specification ..... 35  
 BCA GENERATOR (60 HERTZ ONLY) ..... 52  
 BC GENERATOR (60 - 50 HERTZ) ..... 51  
 Break-In Precautions..... 29

**C**

CAUTION

BELT TENSION..... 46  
 CLAMP THREAD TORQUE LIMIT ..... 18  
 DO NOT DISCONNECT DC BATTERY SOURCE WITH ENGINE ON ..... 22  
 DO NOT LEAVE OIL IN SUMP OVER LAY-UP PERIOD..... 71  
 DO NOT USE SCOOP-TYPE THROUGH-HULL FITTING..... 22  
 ENGINE NOT SHIPPED WITH OIL ..... 12  
 NEVER SHUT-OFF ENGINE BATTERY SWITCH WITH ENGINE ON..... 35  
 PROLONGED CRANKING INTERVALS ..... 17 & 28  
 QUICK CHARGING BATTERY WITH EXTERNAL CHARGER ..... 35  
 SLINGS MUST NOT BE SHORT..... 13  
 WHEN STARTING GENERATOR, TURN AC LOADS OFF ..... 28  
 UTILITY SHORE POWER AND GENERATOR OUTPUT..... 56

Carburetor Adjustment ..... 68  
 CARBURETOR AND FUEL SYSTEM ..... 32  
 Choke Solenoid..... 66  
 Connecting Pressure Sensing Devices to Oil Galleries..... 21  
 COOLING SYSTEM..... 21, 42 & 47  
 Cylinder Lubrication..... 72

**D**

DC Electrical Connections..... 22  
 DESCRIPTION OF ENGINE CONTROL PANEL ..... 25  
 DISCLAIMER, PRODUCT SOFTWARE..... 1



**E**

ELECTRICAL SYSTEM ..... 22 & 35  
 Engine 12-Volt DC Control Circuit.....35  
 ENGINE CONTROL PANEL, DESCRIPTION.....25  
 Engine Oil.....48  
 Engine Oil Change.....49  
 Engine Oil Viscosity (SAE Number) .....48  
 ENGINE TROUBLESHOOTING .....59  
 Exhaust Back-Pressure .....16  
 Exhaust Elbow Installation .....18  
 Exhaust System .....15  
 Exhaust System Failures .....17

**F**

FOREWORD.....2  
 Fresh Water Circuit .....42  
 Fresh Water Cooling System.....71  
 Fuel System ..... 19 & 71

**G**

Gasoline .....32  
 GENERAL.....5  
 GENERAL INFORMATION AND CARE OF THE GENERATOR .....57  
 GENERAL SPECIFICATIONS, 7.0 KW BCG & BCGA .....8  
 Generator (AC Output) .....23  
 Generator Frequency .....51  
 Generator Frequency Adjustment.....65  
 Generator Mounting-Location .....14  
 Generator Troubleshooting .....58  
 Governor Adjustments.....67  
 Governor/Fresh Water/Raw Water/Pump Belt Tension.....46  
 Governor Maintenance .....67  
 Grounding .....22

**I**

Ignition Timing .....66  
 Inspection of Equipment .....12  
 INSTALLATION CHECKS .....12  
 Intake Manifold and Through-Hull Exhaust .....72

**L**

LAY-UP AND RECOMMISSIONING.....71  
 Load Connections.....55

LUBRICATION SYSTEM .....48 & 71

**M**

MAINTENANCE AND ADJUSTMENTS ..... 63

**N**

No Load Voltage Adjustment..... 53

**O**

Oil Drain Hose ..... 21  
 Oil Pressure ..... 48  
 Optional Fuel Filter/Water Separator..... 33  
 Optional Remote Instrument and Remote Start Panels ..... 26  
 Ordering Parts ..... 5  
 Overspeed Shutdown ..... 31

**P**

Parts, Ordering ..... 5  
 PREPARATIONS FOR STARTING ..... 27  
 Preventive Maintenance, Engine ..... 63  
 Preventive Maintenance, Generator ..... 58  
 PRODUCT SOFTWARE DISCLAIMER..... 1

**R**

Raw Water Circuit.....45 & 72  
 Raw Water Intake System..... 21  
 Raw Water Pump..... 45  
 Recommissioning..... 73  
 Remote Starting Procedure ..... 30  
 Remote Stopping Procedure..... 31  
 Replacing Filter Elements ..... 33  
 Required Operating Speed ..... 57  
 Rigging and Lifting ..... 13

**S**

Shore Power Connections..... 56  
 SPARE PARTS LIST ..... 74  
 Spares..... 72  
 Spark Plugs ..... 70  
 SPECIFICATIONS, GENERAL, 7.0 KW BCG & BCGA..... 8

SPECIFICATIONS, SYSTEM, 7.0 KW BCG & BCGA .....9  
 Starter Motor .....72  
 STARTING PROCEDURE .....28  
 Starting Under Cold Conditions .....29  
 Starting Under Normal Conditions .....29  
 STOPPING PROCEDURE .....31  
 SYSTEM SPECIFICATIONS, 7.0 KW BCG & BCGA  
     AC Generator .....11  
     Cooling .....9  
     Electrical .....10  
     Fuel .....9  
     Ignition .....9  
     Intake .....9  
     Lubrication .....10  
     Tune-Up .....11

**T**

TABLE OF CONTENTS .....3  
 TABLE OF STANDARD HARDWARE TIGHTENING TORQUES .....75  
 TABLE OF TIGHTENING TORQUES .....76  
 Testing the Battery Charging Circuit .....36  
 Thermostat .....44  
 Torquing Cylinder Head Bolts .....69

**U**

Understanding the Gasoline Engine-Driven Generator .....5  
 Use of Electric Motors .....57

**V**

Valve Clearance Adjustment .....70  
 Ventilation .....24

**W**



**CARBON MONOXIDE GAS IS DEADLY! ..... 15 & 28**  
**DO NOT ATTEMPT A NO-LOAD ADJUSTMENT WITH ENGINE ON..... 53**  
**DO NOT SMOKE NEAR BATTERIES..... 23**  
**FUEL LEAKAGE ..... 20 & 34**  
**INSTALLING THE OPTIONAL REMOTE PANELS ..... 26**  
**NEVER ADJUST DRIVE BELT TENSION WITH ENGINE ON ..... 46**  
**OVERSPEED SHUTDOWN MUST BE FUNCTIONING ..... 31**  
**REMOVE SPARK PLUGS ONLY WHEN ENGINE IS COOL ..... 70**  
**WEAR PROTECTION WHEN SERVICING BATTERIES ..... 24 & 73**

WIRING DIAGRAM #38024, OPTIONAL REMOTE START PANEL ..... 40  
WIRING DIAGRAM #38025, OPTIONAL REMOTE INSTRUMENT PANEL ..... 41  
WIRING DIAGRAM #38028, DC CONTROL CIRCUIT .....38 & 39

**Z**

Zinc Anodes ..... 45



## NOTES

[www.torresen.com](http://www.torresen.com)