



SERVICE MANUAL
FOR THE
82B FOUR MARINE DIESEL ENGINE
AND THE
25KW-60Hz BED / 20KW-50Hz BED
MARINE DIESEL GENERATORS
SINGLE PHASE & THREE PHASE

PUBLICATION NO. 040485
EDITION ONE
NOVEMBER 1998

WESTERBEKE
WESTERBEKE CORPORATION
MYLES STANDISH INDUSTRIAL PARK
150 JOHN HANCOCK ROAD, TAUNTON, MA 02780-7319

 *Member National Marine Manufacturers Association*

**CALIFORNIA
PROPOSITION 65 WARNING**

Diesel engine exhaust and some of its constituents are known to the State of California to cause cancer, birth defects, and other reproductive harm.

 **WARNING**

Exhaust gasses contain Carbon Monoxide, an odorless and colorless gas. Carbon Monoxide is poisonous and can cause unconsciousness and death. Symptoms of Carbon Monoxide exposure can include:

- *Dizziness*
- *Nausea*
- *Headache*
- *Weakness and Sleepiness*
- *Throbbing in Temples*
- *Muscular Twitching*
- *Vomiting*
- *Inability to Think Coherently*

IF YOU OR ANYONE ELSE EXPERIENCE ANY OF THESE SYMPTOMS, GET OUT INTO THE FRESH AIR IMMEDIATELY. If symptoms persist, seek medical attention. Shut down the unit and do not restart until it has been inspected and repaired.

SAFETY INSTRUCTIONS

INTRODUCTION

Read this safety manual carefully. Most accidents are caused by failure to follow fundamental rules and precautions. Know when dangerous conditions exist and take the necessary precautions to protect yourself, your personnel, and your machinery.

The following safety instructions are in compliance with the American Boat and Yacht Council (ABYC) standards.

PREVENT ELECTRIC SHOCK

⚠ WARNING: Do not touch AC electrical connections while engine is running, or when connected to shore power. Lethal voltage is present at these connections!

- Do not operate this machinery without electrical enclosures and covers in place.
- Shut off electrical power before accessing electrical equipment.
- Use insulated mats whenever working on electrical equipment.
- Make sure your clothing and skin are dry, not damp (particularly shoes) when handling electrical equipment.
- Remove wristwatch and all jewelry when working on electrical equipment.
- Do not connect utility shore power to vessel's AC circuits, except through a ship-to-shore double throw transfer switch. Damage to vessel's AC generator may result if this procedure is not followed.
- Electrical shock results from handling a charged capacitor. Discharge capacitor by shorting terminals together.

PREVENT BURNS — HOT ENGINE

⚠ WARNING: Do not touch hot engine parts or exhaust system components. A running engine gets very hot!

- Always check the engine coolant level at the coolant recovery tank.

⚠ WARNING: Steam can cause injury or death!

- In case of an engine overheat, allow the engine to cool before touching the engine or checking the coolant.

PREVENT BURNS — FIRE

⚠ WARNING: Fire can cause injury or death!

- Prevent flash fires. Do not smoke or permit flames or sparks to occur near the carburetor, fuel line, filter, fuel pump, or other potential sources of spilled fuel or fuel vapors. Use a suitable container to catch all fuel when removing the fuel line, carburetor, or fuel filters.
- Do not operate with a Coast Guard Approved flame arrester removed. Backfire can cause severe injury or death.
- Do not operate with the air cleaner/silencer removed. Backfire can cause severe injury or death.
- Do not smoke or permit flames or sparks to occur near the fuel system. Keep the compartment and the engine/generator clean and free of debris to minimize the chances of fire. Wipe up all spilled fuel and engine oil.
- Be aware — diesel fuel will burn.

PREVENT BURNS — EXPLOSION

⚠ WARNING: Explosions from fuel vapors can cause injury or death!

- Follow re-fueling safety instructions. Keep the vessel's hatches closed when fueling. Open and ventilate cabin after fueling. Check below for fumes/vapor before running the blower. Run the blower for four minutes before starting your engine.
- All fuel vapors are highly explosive. Use extreme care when handling and storing fuels. Store fuel in a well-ventilated area away from spark-producing equipment and out of the reach of children.
- Do not fill the fuel tank(s) while the engine is running.
- Shut off the fuel service valve at the engine when servicing the fuel system. Take care in catching any fuel that might spill. DO NOT allow any smoking, open flames, or other sources of fire near the fuel system or engine when servicing. Ensure proper ventilation exists when servicing the fuel system.
- Do not alter or modify the fuel system.
- Be sure all fuel supplies have a positive shutoff valve.
- Be certain fuel line fittings are adequately tightened and free of leaks.
- Make sure a fire extinguisher is installed nearby and is properly maintained. Be familiar with its proper use. Extinguishers rated ABC by the NFPA are appropriate for all applications encountered in this environment.



SAFETY INSTRUCTIONS

ACCIDENTAL STARTING

⚠ WARNING: Accidental starting can cause injury or death!

- Disconnect the battery cables before servicing the engine/generator. Remove the negative lead first and reconnect it last.
- Make certain all personnel are clear of the engine before starting.
- Make certain all covers, guards, and hatches are re-installed before starting the engine.

BATTERY EXPLOSION

⚠ WARNING: Battery explosion can cause injury or death!

- Do not smoke or allow an open flame near the battery being serviced. Lead acid batteries emit hydrogen, a highly explosive gas, which can be ignited by electrical arcing or by lit tobacco products. Shut off all electrical equipment in the vicinity to prevent electrical arcing during servicing.
- Never connect the negative (-) battery cable to the positive (+) connection terminal of the starter solenoid. Do not test the battery condition by shorting the terminals together. Sparks could ignite battery gases or fuel vapors. Ventilate any compartment containing batteries to prevent accumulation of explosive gases. To avoid sparks, do not disturb the battery charger connections while the battery is being charged.
- Avoid contacting the terminals with tools, etc., to prevent burns or sparks that could cause an explosion. Remove wristwatch, rings, and any other jewelry before handling the battery.
- Always turn the battery charger off before disconnecting the battery connections. Remove the negative lead first and reconnect it last when disconnecting the battery.

BATTERY ACID

⚠ WARNING: Sulfuric acid in batteries can cause severe injury or death!

- When servicing the battery or checking the electrolyte level, wear rubber gloves, a rubber apron, and eye protection. Batteries contain sulfuric acid which is destructive. If it comes in contact with your skin, wash it off at once with water. Acid may splash on the skin or into the eyes inadvertently when removing electrolyte caps.

TOXIC EXHAUST GASES

⚠ WARNING: Carbon monoxide (CO) is a deadly gas!

- Ensure that the exhaust system is adequate to expel gases discharged from the engine. Check the exhaust system regularly for leaks and make sure the exhaust manifolds are securely attached and no warping exists. Pay close attention to the manifold, water injection elbow, and exhaust pipe nipple.
- Be sure the unit and its surroundings are well ventilated.
- In addition to routine inspection of the exhaust system, install a carbon monoxide detector. Consult your boat builder or dealer for installation of approved detectors.
- For additional information refer to ABYC T-22 (educational information on Carbon Monoxide).

⚠ WARNING: Carbon monoxide (CO) is an invisible odorless gas. Inhalation produces flu-like symptoms, nausea or death!

- Do not use copper tubing in diesel exhaust systems. Diesel fumes can rapidly destroy copper tubing in exhaust systems. Exhaust sulfur causes rapid deterioration of copper tubing resulting in exhaust/water leakage.
- Do not install exhaust outlet where exhaust can be drawn through portholes, vents, or air conditioners. If the engine exhaust discharge outlet is near the waterline, water could enter the exhaust discharge outlet and close or restrict the flow of exhaust. Avoid overloading the craft.
- Although diesel engine exhaust gases are not as toxic as exhaust fumes from gasoline engines, carbon monoxide gas is present in diesel exhaust fumes. Some of the symptoms or signs of carbon monoxide inhalation or poisoning are:
 - Vomiting
 - Dizziness
 - Throbbing in temples
 - Muscular twitching
 - Intense headache
 - Weakness and sleepiness

AVOID MOVING PARTS

⚠ WARNING: Rotating parts can cause injury or death!

- Do not service the engine while it is running. If a situation arises in which it is absolutely necessary to make operating adjustments, use extreme care to avoid touching moving parts and hot exhaust system components.



SAFETY INSTRUCTIONS

- Do not wear loose clothing or jewelry when servicing equipment; tie back long hair and avoid wearing loose jackets, shirts, sleeves, rings, necklaces or bracelets that could be caught in moving parts.
- Make sure all attaching hardware is properly tightened. Keep protective shields and guards in their respective places at all times.
- Do not check fluid levels or the drive belt's tension while the engine is operating.
- Stay clear of the drive shaft and the transmission coupling when the engine is running; hair and clothing can easily be caught in these rotating parts.

HAZARDOUS NOISE

 **WARNING: High noise levels can cause hearing loss!**

- Never operate an engine without its muffler installed.
- Do not run an engine with the air intake (silencer) removed.
- Do not run engines for long periods with their enclosures open.

 **WARNING: Do not work on machinery when you are mentally or physically incapacitated by fatigue!**

OPERATORS MANUAL

Many of the preceding safety tips and warnings are repeated in your Operators Manual along with other cautions and notes to highlight critical information. Read your manual carefully, maintain your equipment, and follow all safety procedures.

ENGINE INSTALLATIONS

Preparations to install an engine should begin with a thorough examination of the American Boat and Yacht Council's (ABYC) standards. These standards are a combination of sources including the USCG and the NFPA.

Sections of the ABYC standards of particular interest are:

- H-2 Ventilation
- P-1 Exhaust systems
- P-4 Inboard engines
- E-9 DC Electrical systems

All installations must comply with the Federal Code of Regulations (FCR).

ABYC, NFPA AND USCG PUBLICATIONS FOR INSTALLING DIESEL ENGINES

Read the following ABYC, NFPA and USCG publications for safety codes and standards. Follow their recommendations when installing your engine.

ABYC (American Boat and Yacht Council)
"Safety Standards for Small Craft"

Order from:

ABYC
15 East 26th Street
New York, NY 10010

NFPA (National Fire Protection Association)
"Fire Protection Standard for Motor Craft"

Order from:

National Fire Protection Association
11 Tracy Drive
Avon Industrial Park
Avon, MA 02322

USCG (United States Coast Guard)
"USCG 33CFR183"

Order from:

U.S. Government Printing Office
Washington, D.C. 20404

INSTALLATION

When installing WESTERBEKE engines and generators it is important that strict attention be paid to the following information:

CODES AND REGULATIONS

Strict federal regulations, ABYC guidelines, and safety codes must be complied with when installing engines and generators in a marine environment.

SIPHON-BREAK

For installations where the exhaust manifold/water injected exhaust elbow is close to or will be below the vessel's waterline, provisions must be made to install a siphon-break in the raw water supply hose to the exhaust elbow. This hose must be looped a minimum of 20" above the vessel's waterline. *Failure to use a siphon-break when the exhaust manifold injection port is at or below the load waterline will result in raw water damage to the engine and possible flooding of the boat.*

EXHAUST SYSTEM

The exhaust hose must be certified for marine use. The system must be designed to prevent water from entering the exhaust under any sea conditions and at any angle of the vessels hull.

A detailed 40 page Marine Installation Manual covering gasoline and diesel, engines and generators, is available from your WESTERBEKE dealer.



TABLE OF CONTENTS

Introduction	2	Engine Torque Specifications	57
Engine Troubleshooting (Chart)	3	Standard Hardware Torques	58
Testing for Overhaul	7	Generator Information	59
Engine / Generator Disassembly	8	Generator Control Panel Switches	60
Engine Disassembly	9	Control Panel Troubleshooting	61
Engine Inspection	14	BE Generator	62
Engine Assembly	24	Generator AC Voltage Connections	63
Exhaust Manifold/Heat Exchanger	31	Voltage Regulator Adjustments	65
Fuel Injection Pump	32	Internal Wiring Schematics	66
Fuel Injection Pump/Fuel lift pump	33	Internal Wiring Schematics	67
Fuel Injectors	34	BE Troubleshooting	68
Fuel System Troubleshooting	36	Electronic Governor	69
Glow Plugs	38	Troubleshooting the Electronic Governor	70
Engine Adjustments	39	Shore Power Transfer Switch	71
Coolant Circulating Pump	41	BED Generator Wiring Schematic	72
Lubricating Oil Pump	42	Remote Start/Stop Panel Wiring Diagram	72
Oil Pressure	43	BED Generator Wiring Diagram	73
Starter Motor	45	BED Generator Wiring Diagram	74
Tachometer	49	BED Generator Wiring Schematic	75
Alternator Testing	50	Generator Specifications	76
Engine Wiring Diagram	52	Special Tools - Generator	78
Engine Wiring Schematic	53	Metric Conversions	79
Engine Specifications	54	Index	80
Engine Standards and Limits	55		

INTRODUCTION

PRODUCT SOFTWARE

Product software (tech data, parts lists, manuals, brochures and catalogs) provided from sources other than WESTERBEKE are not within WESTERBEKE'S control.

WESTERBEKE CANNOT BE RESPONSIBLE FOR THE CONTENT OF SUCH SOFTWARE, MAKES NO WARRANTIES OR REPRESENTATIONS WITH RESPECT THERETO, INCLUDING ACCURACY, TIMELINESS OR COMPLETENESS THEREOF AND WILL IN NO EVENT BE LIABLE FOR ANY TYPE OF DAMAGE OR INJURY INCURRED IN CONNECTION WITH OR ARISING OUT OF THE FURNISHING OR USE OF SUCH SOFTWARE. WESTERBEKE customers should also keep in mind the time span between printings of WESTERBEKE product software and the unavoidable existence of earlier WESTERBEKE manuals. Product software provided with WESTERBEKE products, whether from WESTERBEKE or other suppliers, must not and cannot be relied upon exclusively as the definitive authority on the respective product. It not only makes good sense but is imperative that appropriate representatives of WESTERBEKE or the supplier in question be consulted to determine the accuracy and currentness of the product software being consulted by the customer.

NOTES, CAUTIONS AND WARNINGS

As this manual takes you through the disassembly, inspection and assembly procedure of your engine/generator, critical information will be highlighted by NOTES, CAUTIONS, and WARNINGS. An explanation follows:

NOTE: *An operating procedure essential to note.*

CAUTION: *Procedures, which if not strictly observed, can result in the damage or destruction of your engine/generator.*

WARNING: *Procedures, which if not properly followed, can result in personal injury or loss of life.*

ORDERING PARTS

Whenever replacement parts are needed, always provide the generator model number, engine serial number, and generator serial number as they appear on the silver and black name-plate located on the generator end. You must provide us with this information so we may properly identify your engine/generator. In addition, include a complete part description and part number for each part needed (see the separately furnished Parts List). Also insist upon WESTERBEKE packaged parts because *will fit* or generic parts are frequently not made to the same specifications as original equipment.

CUSTOMER IDENTIFICATION CARD



Customer Identification
WESTERBEKE OWNER
MAIN STREET
HOMETOWN, USA

Model 82B Ser. #00000-D911
Expires 9/1/99

The WESTERBEKE serial number is an alphanumeric number that can assist in determining the date of manufacture of your WESTERBEKE engine/generator. The first character indicates the decade (A=1960s, B=1970s, C=1980s, D=1990s), the second character represents the year in the decade, and the fourth and fifth number represents the month of manufacture.

SERIAL NUMBER LOCATION

The engine and generator serial numbers and model numbers are located on a decal on the generator housing.

The engine serial number can also be found stamped into the engine block just above the injection pump. The generator serial number is stamped into the generator housing on the flat surface on the left side of the generator.

An identification plate on the engine manifold also displays the engine model and serial number.

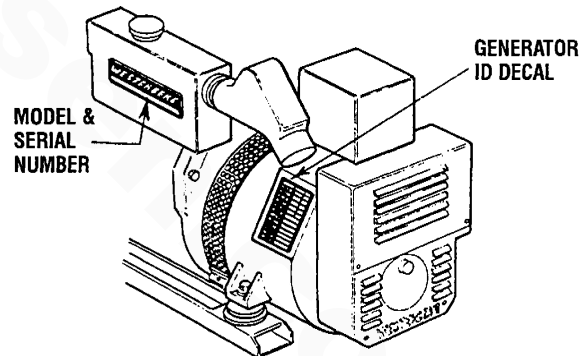

ENGINE OVERHAUL

The following sections contain detailed information relating to the proper operation characteristics of the major components and systems of the engine. Included are disassembly, inspection and reassembly instructions for the guidance of suitable equipped and staffed marine engine service and rebuilding facilities. The necessary procedures should be undertaken only by such facilities.

Additional detailed information and specifications are provided in other sections of this manual, covering the generator, alternator, starter motor, engine adjustments, cooling pumps, etc.



ENGINE TROUBLESHOOTING

The following troubleshooting chart describes certain problems relating to engine service, the probable causes of these problems, and the recommendations to overcome these problems. This chart may be of assistance in determining the need for an engine overhaul.

NOTE: *The engine's electrical system is protected by a 20-ampere manual reset circuit breaker. The preheat solenoid is mounted on the same bracket.*

PROBLEM	PROBABLE CAUSE	VERIFICATION/REMEDY
HARD STARTING	LOW CRANKING SPEED 1. Engine oil viscosity too high. 2. Run-down battery. 3. Worn battery. 4. Battery terminals loosely connected. 5. Defective starter.	1. Replace engine oil with less viscous oil. 2. Recharge battery. 3. Replace battery. 4. Clean terminals and correct cables. 5. Repair or replace starter.
	DEFECTIVE INJECTION SYSTEM 1. Air trapped in fuel passage. 2. Clogged fuel filter. 3. Low injection pressure. 4. Inadequate spray. 5. Injection pump delivering insufficient fuel. 6. Injection too early.	1. Bleed air from fuel system. 2. Clean or replace filter. 3. Adjust injection pressure. 4. Clean or replace nozzle. 5. Repair or replace injection pump. 6. Adjust injection timing.
	MAIN ENGINE TROUBLES 1. Low compression. a. Incorrect valve clearance. b. Inadequate contact of valve seat. c. Valve stem seized. d. Broken valve spring. e. Compression leaks through cylinder head gasket. f. Piston ring seized. g. Worn piston ring and cylinder. 2. Burnt glow plug. 3. Faulty glow plug operation. 4. Incorrect governor lever position.	a. Adjust valve clearance. b. Lap valve. c. Replace valve and valve guide. d. Replace valve spring. e. Replace gasket. f. Replace piston and piston ring. g. Overhaul engine. 2. Replace glow plug. 3. Correct lead wire connection, check preheat solenoid. 4. Set lever to starting position.
LOW OUTPUT	LOW COMPRESSION	See <i>HARD STARTING</i>
	INJECTION SYSTEM OUT OF ADJUSTMENT 1. Incorrect injection timing. 2. Insufficient injection. 3. Low injection pressure.	1. Adjust injection timing. 2. Repair or replace injection pump. 3. Check injection nozzle and adjust pressure.
	INSUFFICIENT FUEL 1. Air trapped in fuel system. 2. Clogged filter. 3. Contaminated fuel tank.	1. Check and retighten connector. 2. Clean or replace filter. 3. Clean tank.
	INSUFFICIENT INTAKE AIR 1. Clogged air intake silencer.	1. Clean or replace air cleaner.

(continued)



ENGINE TROUBLESHOOTING

PROBLEM	PROBABLE CAUSE	VERIFICATION/REMEDY
LOW OUTPUT (cont.)	OVERHEATING 1. Low coolant level. 2. Loose V-belt. 3. Incorrect injection timing. 4. Low engine oil level.	1. Add coolant. 2. Adjust or replace V-belt. 3. Adjust injection timing. 6. Add engine oil.
EXCESSIVE OIL CONSUMPTION	OIL LEAKAGE 1. Defective oil seals. 2. Broken gear case gasket. 3. Loose gear case attaching bolts. 4. Loose drain hose attachment. 5. Loose oil pipe connector. 6. Broken rocker cover gasket. 7. Loose rocker cover attaching bolts.	1. Replace oil seals. 2. Replace gasket. 3. Retighten bolts. 4. Retighten banjo bolt and secure. 5. Retighten oil connections. 6. Replace gasket. 7. Retighten attaching bolts.
	OIL LEVEL RISING 1. Dead cylinder. 2. Displaced or twisted connecting rod. 3. Worn piston ring. 4. Worn piston or cylinder.	1. Check compression. 2. Replace connecting rod. 3. Replace ring. 4. Replace piston and rebore cylinder.
	OIL LEVEL FALLING 1. Defective valve stem seal. 2. Worn valve and valve guide.	1. Replace valve stem seal. 4. Replace a valve and valve guide.
EXCESSIVE FUEL CONSUMPTION	ENGINE BODY TROUBLES 1. Noisy knocking. 2. Smoky exhaust. 3. Moving parts nearly seized or excessively worn. 4. Poor compression. 5. Improper valve timing. 6. Improper valve clearance.	1. See <i>KNOCKING</i> . 2. See <i>SMOKY EXHAUST</i> . 3. Repair or replace. 4. See <i>LOW COMPRESSION; HARD STARTING</i> . 5. Adjust. 6. Adjust.
	INSUFFICIENT INTAKE AIR 1. Air intake obstructed.	1. Remove obstruction.
	NOZZLE TROUBLES 1. Seized nozzle. 2. Worn nozzle.	1. Replace. 2. Replace.
	IMPROPER FUEL	Replace with proper fuel.
	FUEL LEAKS	Find fuel leaks.
SMOKY EXHAUST	WHITISH OR PURPLISH 1. Excessive engine oil. 2. Excessive rise of oil into combustion chamber. <ul style="list-style-type: none"> a. Poor piston contact. b. Seized piston ring. c. Excessive piston-to-cylinder clearance. 	1. Correct oil level. <ul style="list-style-type: none"> a. Check. b. Replace or clean. c. Replace or correct.

(continued)



ENGINE TROUBLESHOOTING

PROBLEM	PROBABLE CAUSE	VERIFICATION/REMEDY
SMOKY EXHAUST (cont.)	WHITISH OR PURPLISH (cont.) d. Worn valve stem and valve guide. e. Low engine oil viscosity. f. Excessive oil pressure. 3. Injection timing is too late. 4. Insufficient compression.	d. Replace. e. Replace. f. Correct. 3. Adjust. 4. See <i>LOW COMPRESSION; HARD STARTING</i> .
	BLACKISH OR DARK GRAYISH 1. Engine body troubles. a. Poor compression. b. Improper valve clearance. 2. Insufficient intake air. 3. Improper fuel.	a. See <i>LOW COMPRESSION; HARD STARTING</i> . b. Adjust. 2. Clear intake. 3. Replace with proper fuel.
ABNORMAL SOUND OR NOISE	CRANKSHAFT AND MAIN BEARING 1. Badly worn bearing. 2. Badly worn crankshaft. 3. Melted bearing.	1. Replace bearing and grind crankshaft. 2. Grind crankshaft. 3. Replace bearing and check lubrication system.
	CONNECTING ROD AND CONNECTING ROD BEARING 1. Worn connecting rod big end bearing. 2. Worn crankpin. 3. Bent connecting rod.	1. Replace bearing. 2. Grind crankshaft. 3. Correct bend or replace.
	PISTON, PISTON PIN, AND PISTON RING 1. Worn cylinder. 2. Worn piston pin. 3. Piston seized. 4. Piston seized and ring worn or damaged.	1. Rebore cylinder to oversize and replace piston. 2. Replace piston. 3. Replace piston and rebore cylinder. 4. Replace piston and rings.
	VALVE MECHANISM 1. Worn camshaft. 2. Excessive valve clearance. 3. Worn timing gear.	1. Replace. 2. Adjust. 3. Replace.
ROUGH OPERATION	INJECTION PUMP SYSTEM 1. Uneven injection. 2. Worn delivery valve. 3. Inadequate injection nozzle spray.	1. Adjust injection or replace parts. 2. Replace. 3. Replace injection nozzle.

(continued)



ENGINE TROUBLESHOOTING

PROBLEM	PROBABLE CAUSE	VERIFICATION/REMEDY
KNOCKING	ENGINE KNOCKS WITHOUT MUCH SMOKE 1. Main engine troubles. a. Overheated cylinder. b. Carbon deposits in cylinder. 2. Too early injection timing. 3. Too high injection pressure. 4. Improper fuel.	a. See <i>OVERHEATING; LOW OUTPUT</i> . b. Clean. 2. Correct. 3. Correct. 4. Replace with proper fuel.
	KNOCKING WITH DARK SMOKE 1. Poor compression. 2. Injection pump malfunctioning. a. Check valve worn/sticking. 3. Improper nozzle. a. Poor spray. b. Poor chattering. c. After-injection drip. d. Nozzle needle valve seized.	1. See <i>LOW COMPRESSION; HARD STARTING</i> . a. Replace check valve. a. Clean or replace nozzle. b. Repair or replace nozzle. c. Repair or replace nozzle. d. Replace.
INTERMITTENT EXHAUST SOUND	1. Fuel filter clogged. 2. Air leak in fuel supply side of system. 3. Water mixed in fuel	1. Clean or replace. 2. Retighten pipe joints or replace pipe. 3. Replace fuel.
OVERHEATING	1. V-belt slackening or slippery with oil. 2. Damaged water pump. 3. Lack of coolant. 4. Low oil level or poor oil quality. 5. Knocking. 6. Moving parts seized or damaged. 7. Defective thermostat.	1. Adjust, replace or clean. 2. Replace. 3. Add. 4. Add or change. 5. See <i>KNOCKING</i> . 6. Replace. 7. Replace.
LOW OIL PRESSURE	1. Worn Bearings. 2. Relief valve malfunction. 3. Clogged oil cooler. 4. Diesel dilution of the oil.	1. Engine overhaul replace bearings. 2. Overhaul oil pump. 3. Repair. 4. Injection pump repair.



TESTING FOR OVERHAUL

HOW TO DETERMINE ENGINE OVERHAUL PERIOD

Cause of Low Compression

Generally, the time at which an engine should be overhauled is determined by various conditions such as lowered engine power output, decreased compression pressure, and increased fuel and oil consumption. The lowered engine power output is not necessarily due to trouble with the engine itself, but is sometimes caused by injector nozzle wear or injection pump wear. The decrease in compression pressure is caused by many factors. It is, therefore, necessary to determine a cause or causes on the basis of data produced by periodic inspection and maintenance. Oil analysis on a seasonal basis is a good means of monitoring engine internal wear. When caused by worn cylinders or piston rings, the following symptoms will occur:

- 1 **Low engine power output**
- 2 **Increased fuel consumption**
- 3 **Increased oil consumption**
- 4 **Hard engine starting**
- 5 **Noisy engine operation**

These symptoms often appear together. Symptoms 2 and 4 can result also from excessive fuel injection, improper injection timing, and wear of plugs and nozzles. They are caused also by defective electrical devices such as the battery, alternator, starter and glow plugs. Therefore it is desirable to judge the optimum engine overhaul time by the lowered compression pressure caused by worn cylinders and pistons plus increased oil consumption. Satisfactory combustion is obtained only under sufficient compression pressure. If an engine lacks compression pressure, incomplete combustion of fuel will take place even if other parts of the engine are operating properly. To determine the period of engine overhaul, it is important to measure the engine compression pressure regularly. At the same time, the engine speed at which the measurement of compression pressure is made should be checked because the compression pressure varies with engine rpm. The engine rpm can be measured at the front end of the crankshaft.

NOTE: To test engine compression see the *ENGINE ADJUSTMENT* section of this manual.

OVERHAUL CONDITIONS

Compression pressure tends to increase a little in a new engine until piston rings and valve seats have been broken in. Thereafter, it decreases gradually with the progress of wear of these parts.

When decrease of compression pressure reaches the repair limit, the engine must be overhauled.

The engine requires overhaul when oil consumption is high, blowby evident, and compression valves are at minimum or below. *Engine compression should be 30 kg/cm², 427 psi at 200 rpm. Cylinder compression should not vary by more than 42.7 psi (3.0 kg/cm²).*

DISASSEMBLY

1. Before disassembly and cleaning, carefully check for defects which cannot be found after disassembly and cleaning.
2. Drain water, fuel and oil before disassembly.
3. Clean or wash the engine exterior.
4. Do not remove or disassemble the parts that require no disassembly.
5. Perform disassembly in a proper order using proper tools. Keep disassembled parts in order. Apply oil when necessary. Take special care to keep the fuel system parts from intrusion of dust and dirt.
6. Carefully check gaskets, packings and oil seals even if checking is not specified. Replace with new ones if defective.

ENGINE/GENERATOR DISASSEMBLY

PROPULSION ENGINE

Unplug the instrument panel wiring harness. Drain the transmission fluid and the transmission oil cooler hoses, Detach the oil cooler hoses and unbolt the transmission from the engine.

Drain or pump out all the engine oil and drain the coolant from the engine and engine hoses.

For transmission service and maintenance refer to your transmission manual. To rebuild a transmission contact your WESTERBEKE dealer or an authorized transmission service shop.

TRANSMISSION

If the transmission is not being rebuilt it should be visually inspected. Flush out and pressure test the oil cooler and replace the coolant hoses. Inspect and lubricate the gear shift linkage and the propeller shaft coupling. Clean and repaint the transmission and change the transmission fluid. Refer to TRANSMISSIONS in this manual.

GENERATOR

Disconnect the AC wiring and unplug the engine's DC wiring harness at the generator control panel. Disconnect the battery cable connections and the engine ground cables.

Separate the exhaust hose at the water injected elbow and disconnect the fuel supply and return lines.

NOTE: Label any lines, hoses or cables as you separate them.

Drain the engine oil and the coolant from the engine.

Carefully support and then unbolt the generator backend from the engine. See *SPECIAL TOOLS - GENERATOR* in this manual.

Additional generator information will be found in the *GENERATOR* section of this manual.

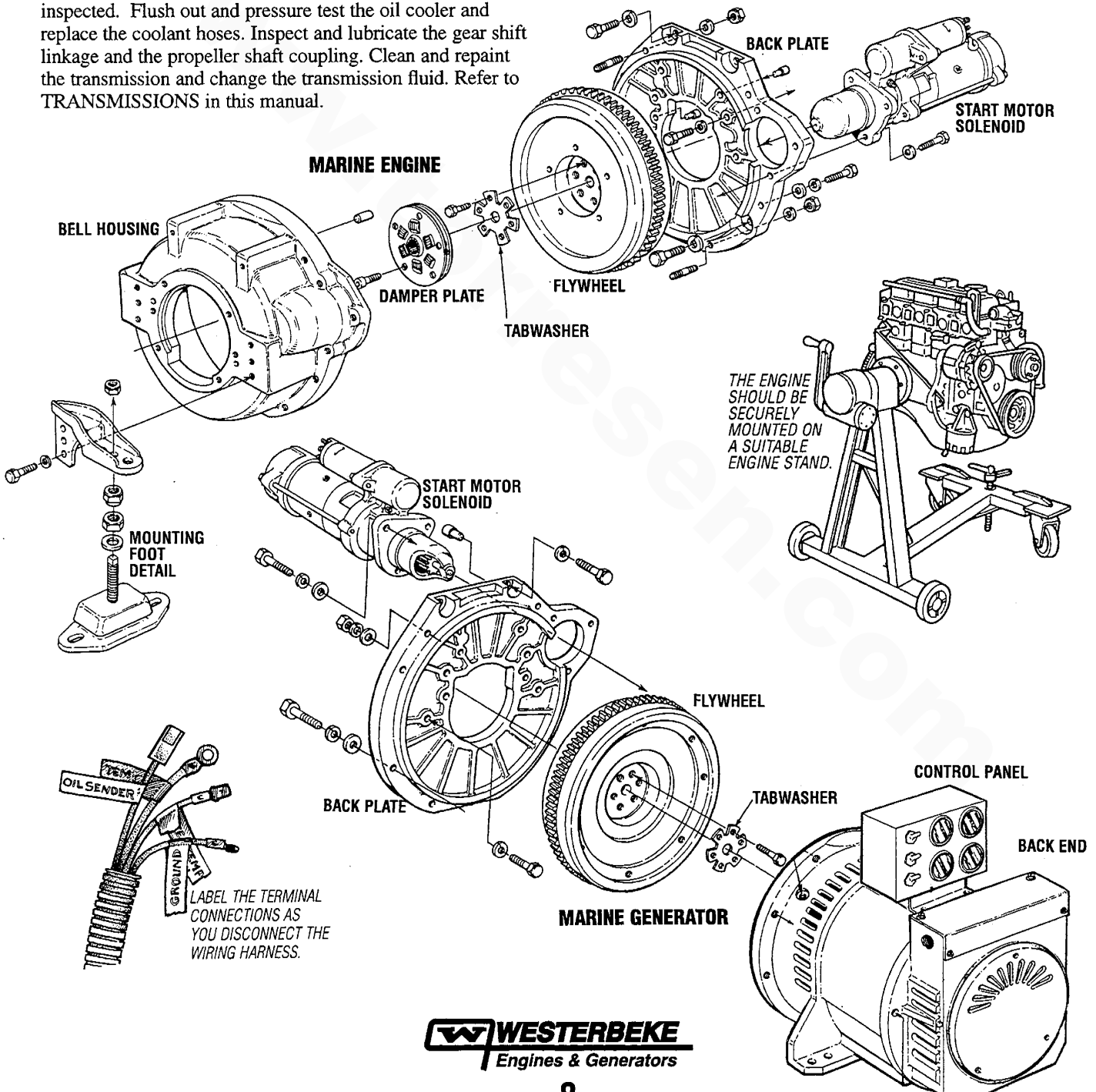

ENGINE DISASSEMBLY

DISASSEMBLING THE MAIN ENGINE

With the transmission/or generator separated from the engine, begin the following step by step procedure to disassemble the engine.

NOTE: Mount the engine on a suitable stand or work bench.

1. Remove the transmission damper plate from the engine flywheel.

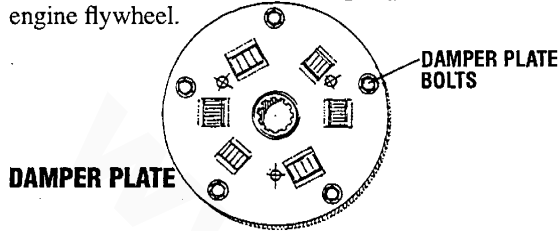

2. Remove the engine oil cooler and oil hoses. Note oil hose connections from the oil cooler to the engine.
3. Remove the engine heat exchanger. If possible, leave one end of each hose connected to the part being removed.
4. Remove the bell housing (propulsion engine) and the circuit breaker/preheat solenoid mounting bracket.
5. Loosen the front crankshaft pulley bolt and remove the flywheel.

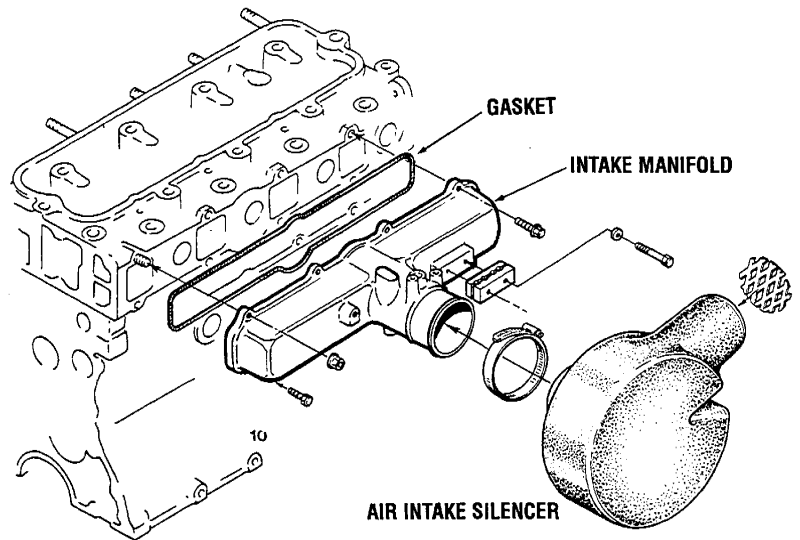

11. Remove the air intake silencer and the intake manifold.
12. Remove the oil filter and the oil cooler mounting bracket from the engine block.

WHEN REMOVING THE MOUNTING BOLTS LOCK THE FLYWHEEL WITH A RING GEAR BREAK TOOL

ONE BOLT DEVIATES 5° FROM THE 60° SET UP

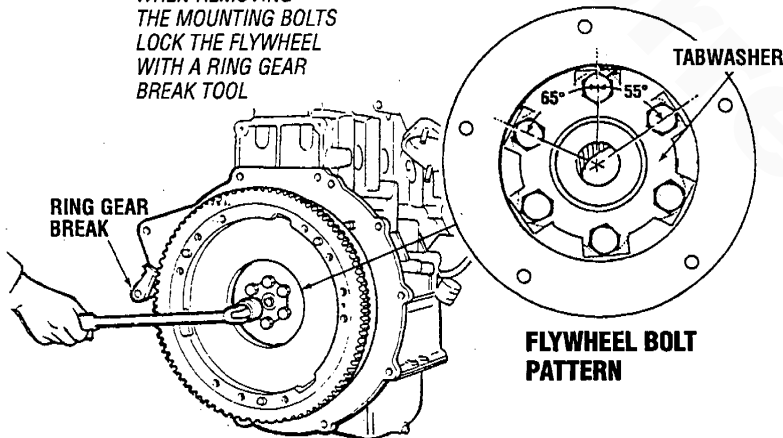

6. Remove the engine back plate.
7. Remove the start motor, drive belt and the alternator. Label the wires and cables.
8. Remove the engine mounted raw water pump, adaptor mounting plate, and drive from the front cover. The drive is removed by turning in a counter clockwise direction. See *RAW WATER PUMP* for parts breakdown.
9. With the hoses disconnected, remove the thermostat housing and housing gasket, leaving the temperature sender in place.
10. Remove the coolant recirculating pump. See *COOLANT RECIRCULATING PUMP* for parts breakdown.

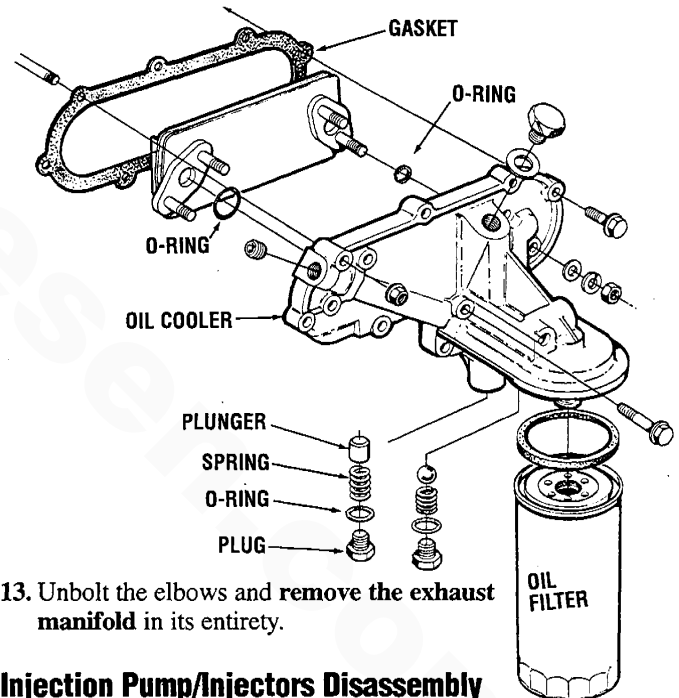

13. Unbolt the elbows and remove the exhaust manifold in its entirety.

Injection Pump/Injectors Disassembly

14. Detach all the high pressure injection lines from the injection pump to the injectors. Leave the two upper line clamps in place.

NOTE: Cap the ends of the lines and the connections at the injection pump and at the injectors to prevent entry of foreign material.

15. Remove the fuel return line from the top of the injectors and from the fuel injection pump by removing the four 12 mm attaching bolts. (Note the washer arrangement on fuel return line banjo bolts. Cap all the openings on the fuel return line, injectors and injection pump.)



ENGINE DISASSEMBLY

16. Remove the fuel injectors, dust seals and sealing washers from the cylinder head using a 27mm deep socket.
17. Remove the glow plugs.
18. Remove the crankcase breather hose and rocker arm cover.
19. Remove the engine mounted fuel filter and fuel line to the injection pump. (Note the arrangement of the sealing washers on the banjo bolts at fuel filter and the injection pump.)
20. Remove the injection pump. Scribe the mating marks on the pump body flange and the timing gear case before removing.

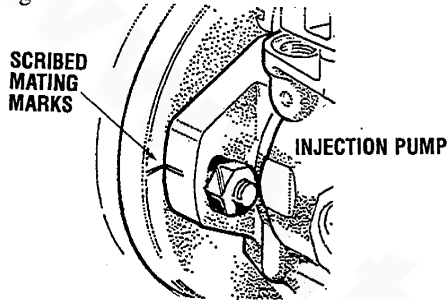

- a. Remove the cover and the locknuts.
- b. Loosen the two injection pump holddown nuts. Do not remove entirely. The holddown nut on the engine side of the pump can be loosened by using a 1/4" universal socket and extension with ratchet.

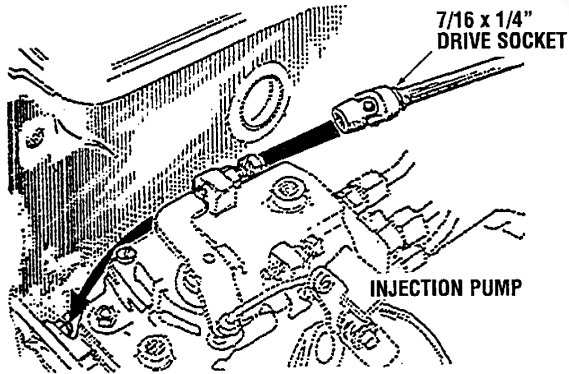

- c. Remove the nut and lockwasher from the injection pump shaft.
- NOTE:** Take care not to drop the nut and the washer into the timing gear case.
- d. Place the keyway on the injection pump shaft in the 12:00 position with the aid of the front crankshaft pulley bolt before attempting to remove the injection pump.
 - e. With the use of extractor Mazda tool #49 SE 01 157 apply sufficient pressure to loosen the pump from the keyed gear. The loose holddown nuts will prevent the pump from falling from the engine.

- f. Once loosened, remove the holddown nuts and washers and carefully withdraw the pump from the drive gear and engine so as to avoid losing the injection pump drive key inside the timing case.

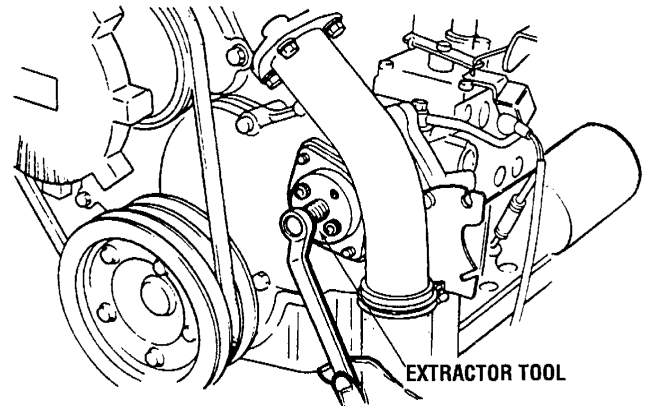
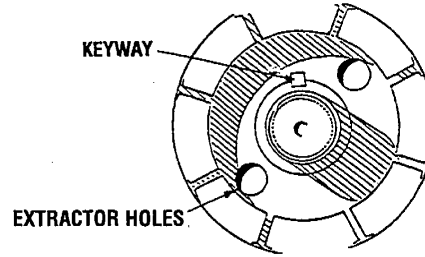

NOTE: If an extractor is not available, replace the nut on the injection pump shaft loosely and with a nylon drift and hammer gently tap the injection pump shaft to dislodge it from the keyed drive gear.

Injection Pump

If the injection pump requires servicing, it should be sent to an injection service shop that can properly service a Kiki-Zexel-Distributor type injection pump.

If the injection pump does not require servicing, it should be wiped clean, covered and set aside until reassembly. Adjustments to timing if needed can be performed after assembly.

See *FUEL INJECTION PUMP*.

Engine Block Disassembly

Disassemble the engine in the following order:

21. Remove the cylinder head rocker cover and gasket.

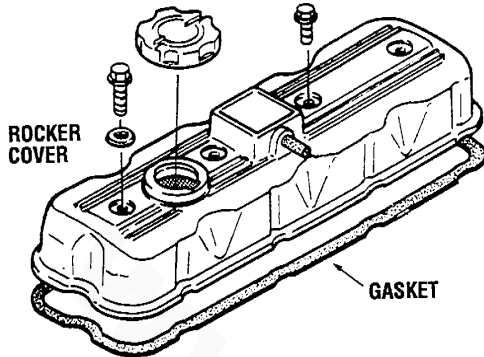

22. Remove the cylinder head.

NOTE: Loosen the cylinder head bolts equally and gradually and in the order shown.

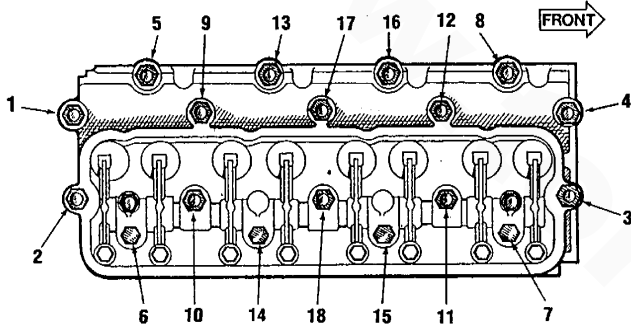

23. Remove the rocker arm assembly.

- a. Remove the valve stem caps so as not to lose them when removing the cylinder head. Label each cap as to which valve it belongs.
- b. Remove the push rods. Label each rod as to which valve it belongs.

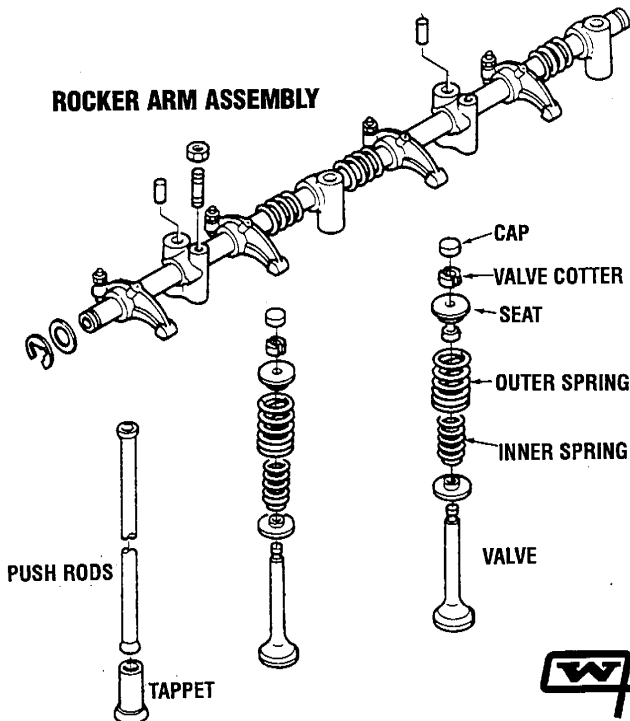

24. Lift the cylinder head off the engine and remove the cylinder head gasket.

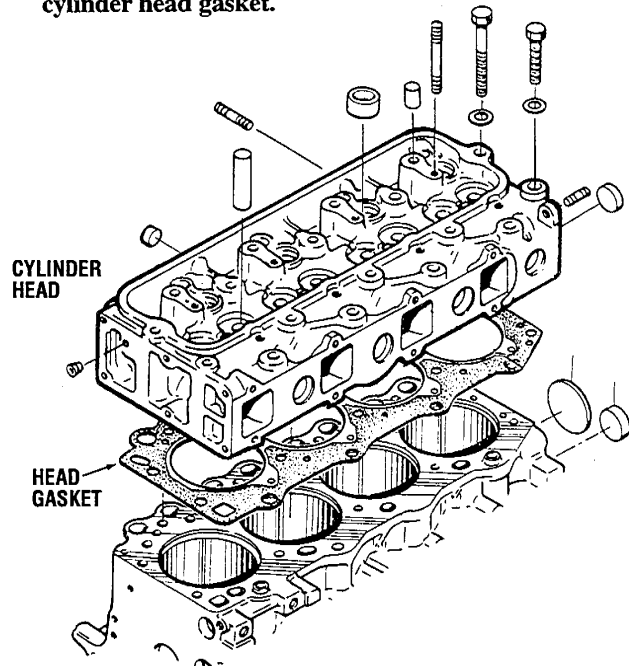

25. Disassemble the rocker arm assembly.

26. Remove each valve from the cylinder head assembly.

Use an appropriate valve spring compressor to aid in disassembly. Arrange or label the valves so as to replace them in the cylinder and guide from which they were removed.

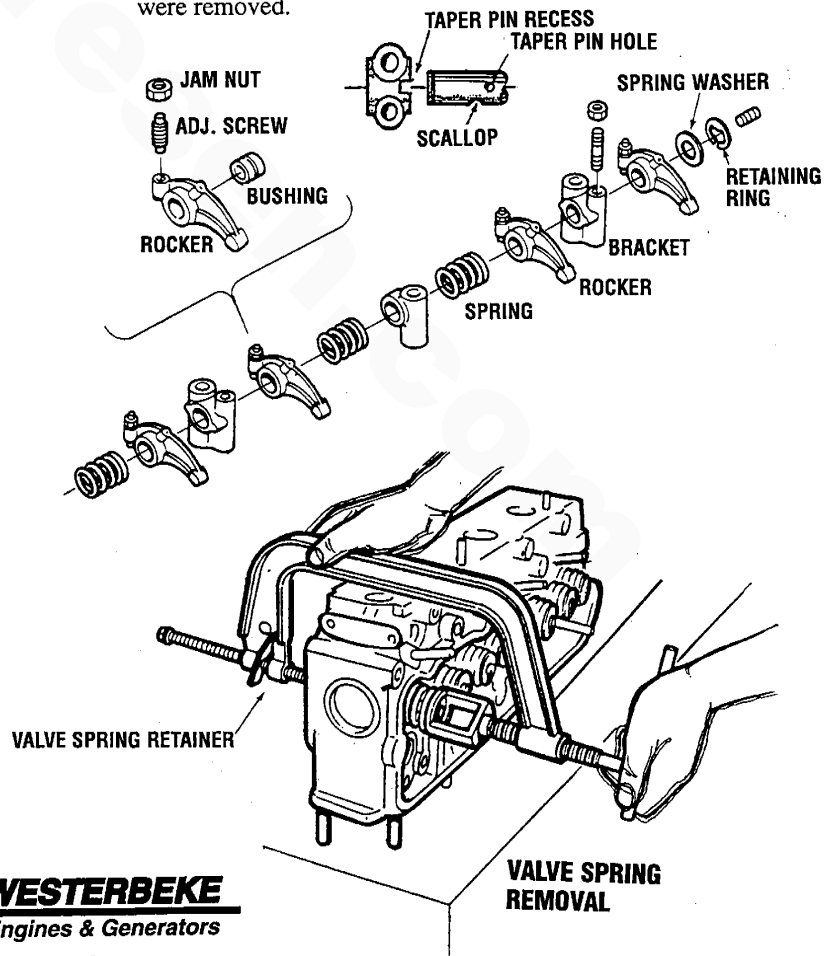

ENGINE DISASSEMBLY

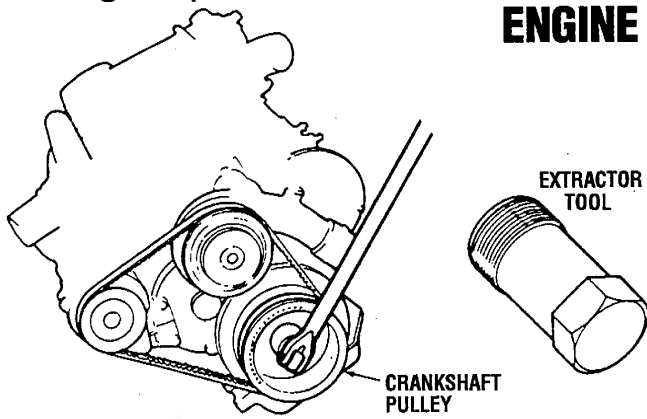

27. Remove the crankshaft pulley bolt with the aid of a 38 mm socket and draw the pulley off the front crankshaft.

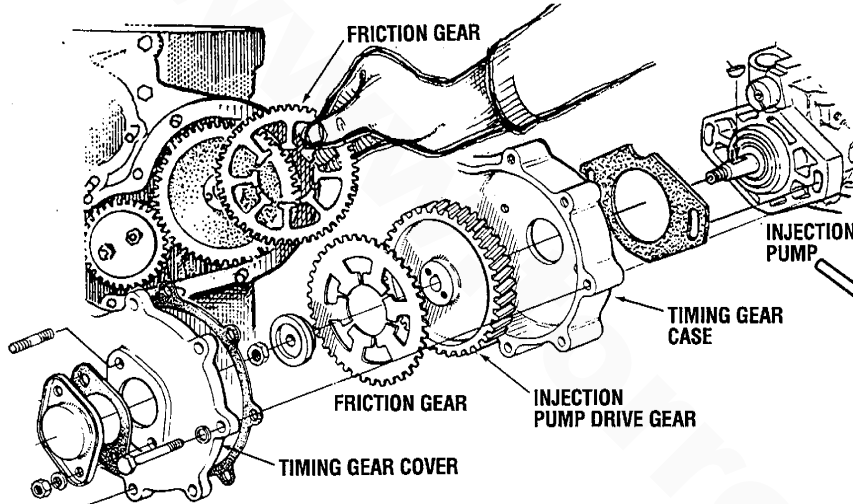
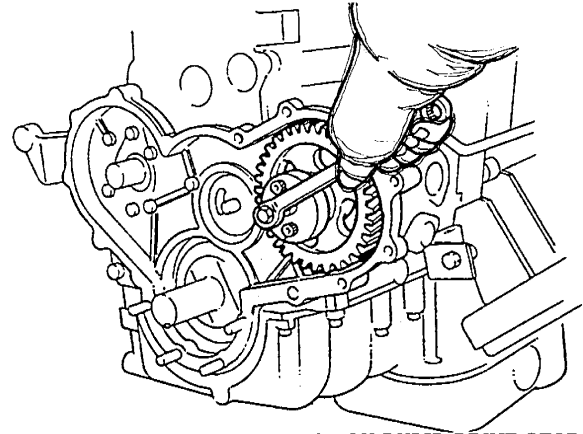

28. Remove the timing gear cover and remove the injection pump washer, injection pump friction gear and the injection pump drive gear.

29. Remove the camshaft gear.

- a. Wedge a clean cloth between the camshaft gear and the idler gear; remove the retaining bolt.
- b. Remove the retaining plate, friction gear and, using a suitable bearing puller, the camshaft gear.

30. Remove the idler gear.

- a. Remove the attaching nuts, thrust plate, idler gear and idler gear hub.

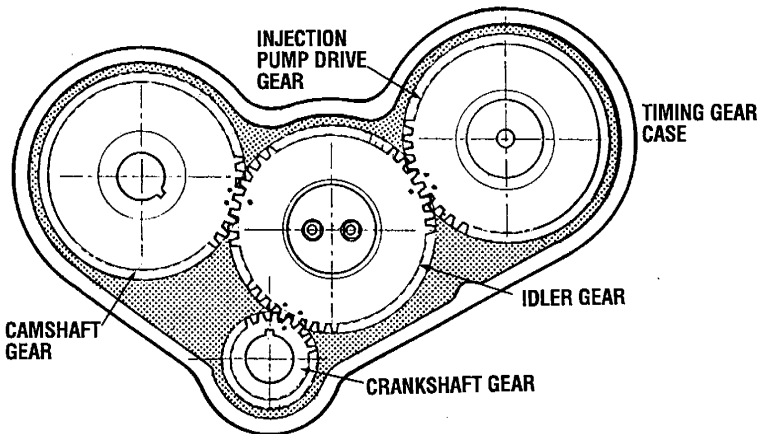
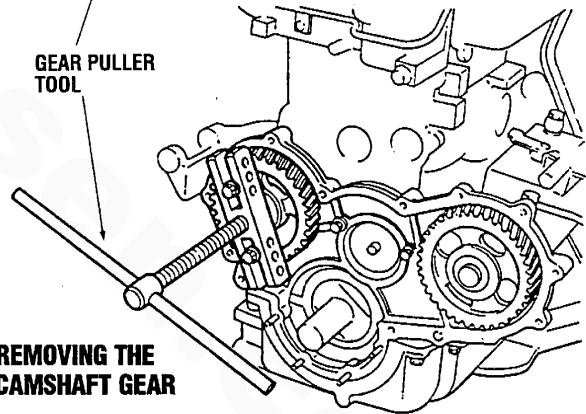
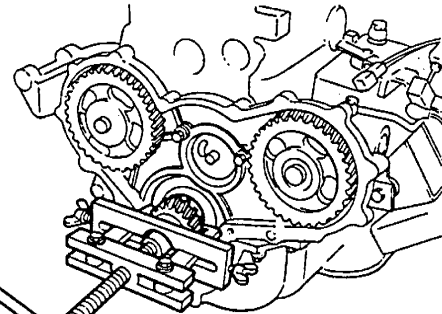

TIMING GEAR DIAGRAM

31. Remove the crankshaft gear.

- a. Remove the wave washer, the friction gear and, using a suitable puller, remove the crankshaft gear and its key.

32. Turn the engine over and remove the oil pan

33. Loosen the oil pump assembly set screw at the side of the block. Remove the oil pump. For oil pump details see *OIL PUMP*.

34. Remove the timing gear case from the front of the engine block. Discard the old gasket.

35. Remove the camshaft. Keep the engine turned over when removing the camshaft. This allows the valve lifters to seat on the block bosses away from the cam lobes.

ENGINE DISASSEMBLY

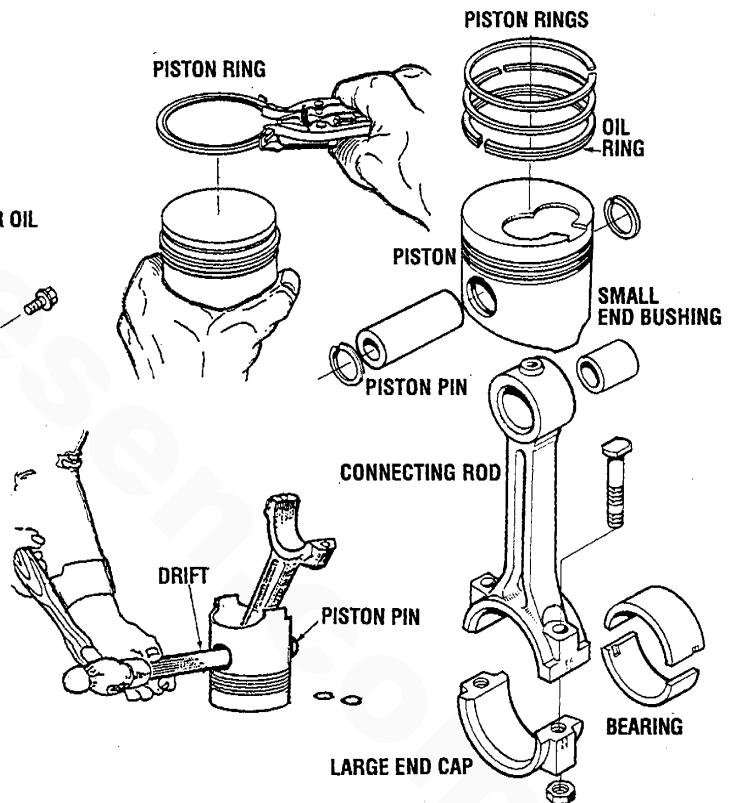
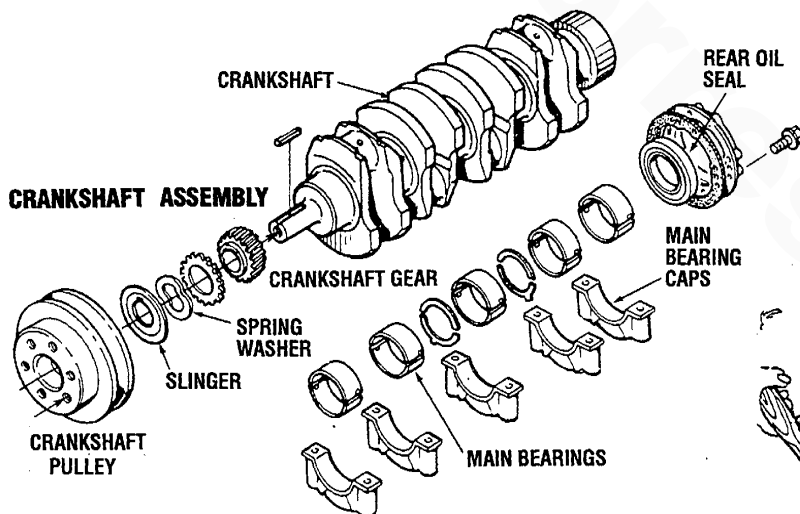
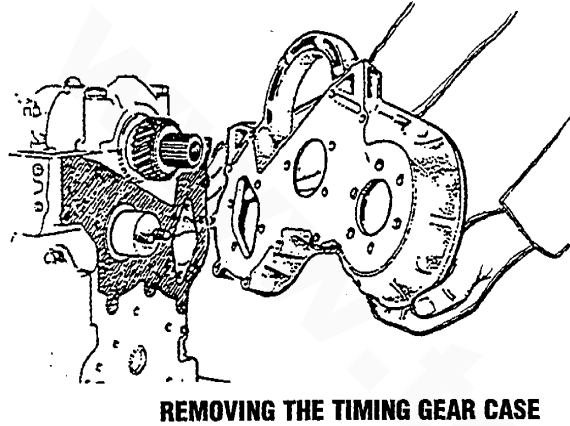
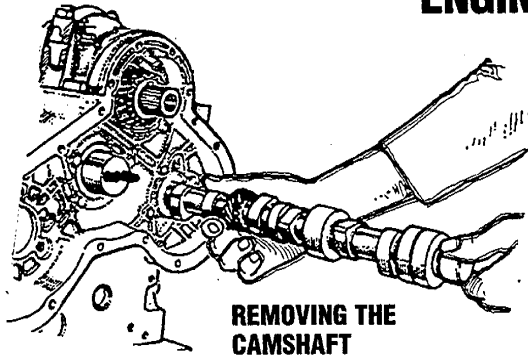

- b. Remove the wrist pin snap rings.
- c. Using a nylon drift, drive the wrist pin from the piston and rod.
- d. Protecting your eyes with safety glasses, disengage and withdraw the snap rings. Although mechanics generally press out (and sometimes hammer out) pistons pins, these practices should be discouraged. Instead, take the time to heat the pistons, either with a heat gun or on a hot plate. Pins will almost fall out.
- e. While the piston is still warm, check for bore integrity. Insert the pin from each side. If the pin binds at the center, the bore might be tapered; if the bore is misaligned, the pin will click or bind as it enters the far boss.

NOTE: The number stamped on the rod shank and cap should correspond to the cylinder number. Sometimes these numbers are scrambled or missing, and the mechanic must supply them. Stamp the correct numbers on the pads provided and, to prevent confusion, deface the originals.

- 36. Remove the rear oil seal by striking out the old seal with a suitable mandrel.
- 37. Disassemble the connecting rod caps and line up the main bearing caps and bearings according to the order of bearing numbers. Also properly arrange the thrust washers, taking care not to change the combination.
- 38. Remove the piston and connecting rod assemblies. Temporarily install the connecting rod cap on the connecting rod so as to not mix the rods and caps.
- 39. Disassemble the piston assembly.
 - a. Using the piston ring remover, remove the piston rings. While removing the piston rings, note the order they are removed and which side of the ring faces the piston crown.

- 40. Remove the main bearing caps.
- 41. Remove the main bearings and thrust bearings.
- 42. Remove the crankshaft.
- 43. Remove the tappets.

NOTE: After removing the main bearings and bearing caps arrange them in order of removal. Do not mix caps. After removing the thrust bearings, note their positioning for proper reinstallation.



ENGINE INSPECTION

INSPECTING THE CYLINDER HEAD

- 1. Visual Inspection.** Check the cylinder head for cracks or any other damage and, if necessary, repair or replace it.
- 2. Distortion Inspection.** Measure the cylinder head surface distortion with a straight edge and the thickness gauge. Take 6 measuring positions as shown in the diagram. If the distortion exceeds permissible limit, replace the cylinder head. (The head has no allowance for planing and must be replaced, not renewed.)

Position	Cylinder Head Distortion Limit
1, 2	0.004 in (0.10mm)
3, 4, 5, 6	0.010 in (0.25mm)

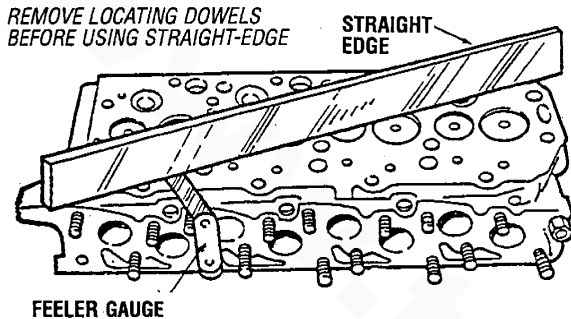

DISTORTION INSPECTION

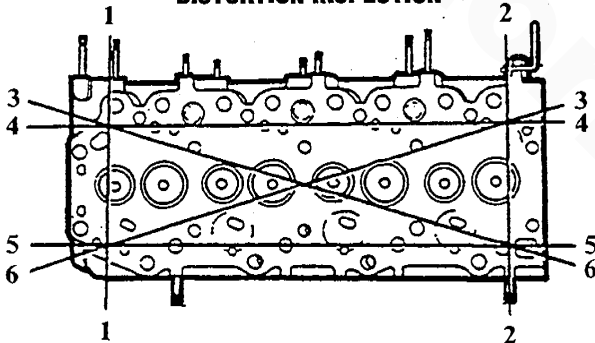

- 3. Insert Inspection.** Check for cracks or damage on the insert and, if detected, replace it.
- 4. Insert Replacement.** To remove the insert, place a suitable drift into the glow plug hole, then tap the drift with a hammer. To install, set the insert in position and insert the welch washer into the insert guide hole. Secure the welch washer by tapping the raised center of the welch washer.
 - Use a new welch washer.
 - Insert the welch washer so that its convex surface is toward the cylinder head gasket.
 - After installation, check to see if the insert is completely fixed in place.

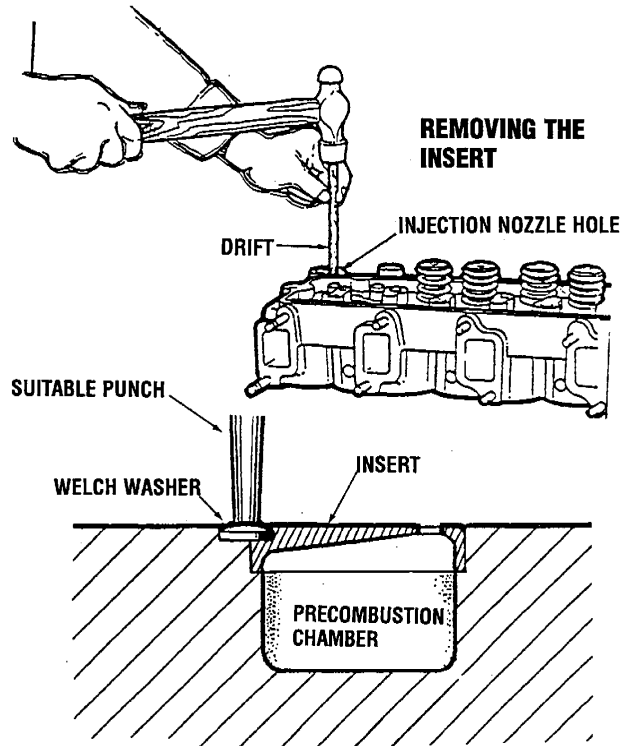

VALVE SPRING

- 1. Free Length Check.** Measure the free length of the valve spring and if free length is less than the limit, replace it.

Valve Spring	Inner 1.654 in (42mm)
	Outer 2.083 in (52.9mm)

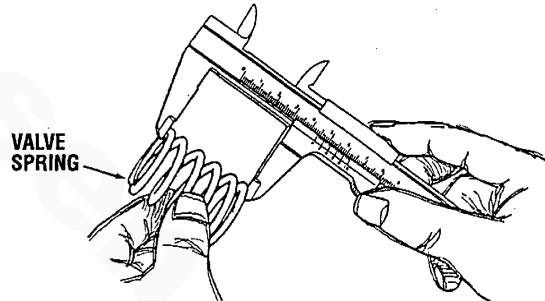

- 2. Squareness Check.** Check the squareness of the valve spring and, if it is more than the limit, replace the spring.

Squareness Limit	Inner 0.049 in (1.25mm)
	Outer 0.054 in (1.37mm)

- 3. Fitting Pressure Check.** Check the valve spring fitting pressure with a valve spring tester and, if the pressure is less than the limit, replace the spring.

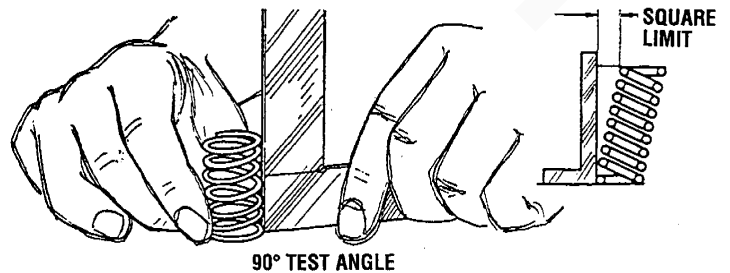

NOTE: Measure the fitting pressure after compressing the spring several times.

Spring Fitting Pressure	Inner	Outer
Fitting Length	1.49 in (37.8mm)	1.59 in (40.3mm)
Fitting Pressure Limit	24.92 lb (11.3kg)	66.36 lb (30.1kg)

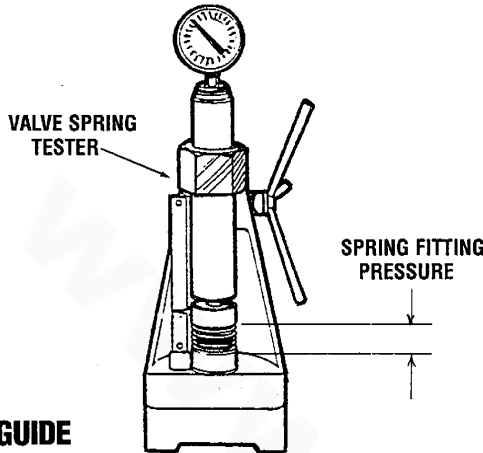

VALVE GUIDE

1. **Inspecting clearance between valve and guide.** Set a dial gauge with a magnet and check the clearance between the valve stem and the valve guide. If the clearance is more than the limit, replace the valve or valve guide.

Clearance Limit 0.005 in (0.127 mm)

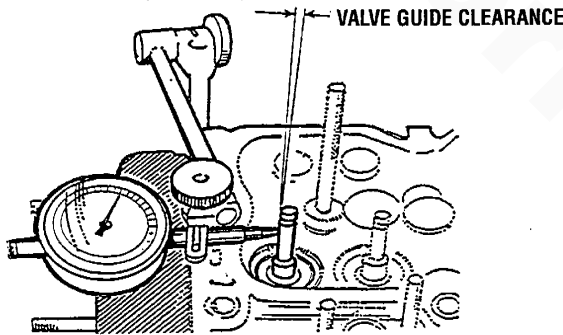

2. **Valve guide replacement.** To remove the valve guide, press out the valve guide towards the combustion chamber side, using the valve guide installer (49 0636 165A). Again using the valve guide installer, press in the valve guide into the cylinder head until the valve guide height reaches the indicated scale on the valve guide installer.

NOTE: Be sure to press in the valve guide so that the inside chamber on the valve guide end faces to the combustion chamber side. After the pressure fit, check the length of the protruding portion of the valve guide.

Protrusion Standard 0.650 in (16.5mm)

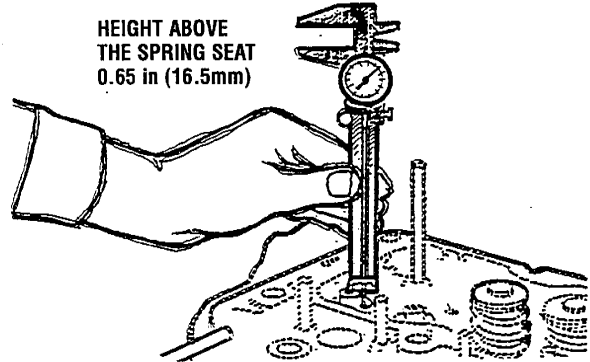
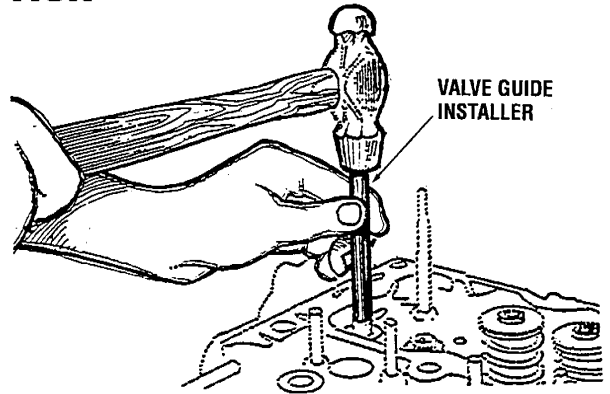

3. **Dimension L.** Check the protruding length of the valve stem, if it exceeds the specification, correct it as follows:
 Dimension L Standard 1.890 in (48.0 mm)

a. When dimension L becomes larger 0 - 0.0202 in (0 - 0.5 mm) from the standard, it is still possible to use both the valve and the cylinder head.

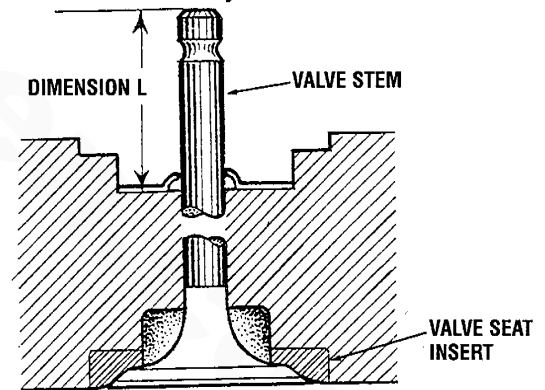

b. When dimension L becomes too large 0.20 - 0.059 in (0.5 - 1.5 mm) from the standard, adjust the dimension L to the standard, by adding some washers (inner diameter 0.504 in (12.8 mm), outer diameter 1.535 in (39 mm) between the lower spring seat and the cylinder head.

c. When dimension L becomes too large (more than 0.059 in (1.5mm) from the standards, replace the valve's seat.

ENGINE INSPECTION

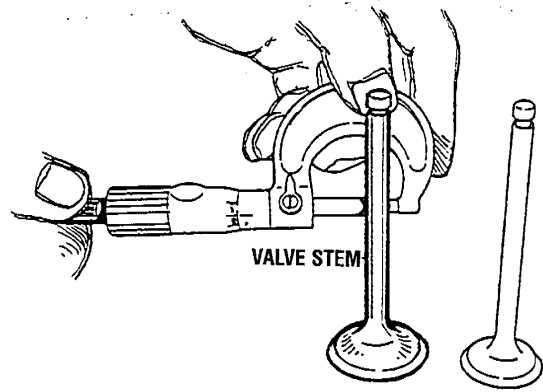
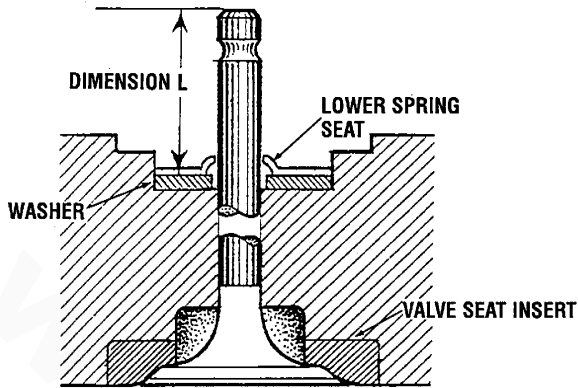

CHECKING VALVE STEM WEAR

d. Check for contact between the valve and valve seat by applying a thin coat of Prussian Blue (or Redlead) on the valve seat contact face, then insert the valve into the valve guide and press fit the valve on the valve seat.

NOTE: Do not rotate the valve!

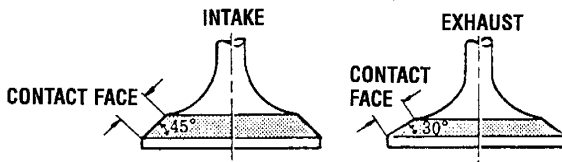
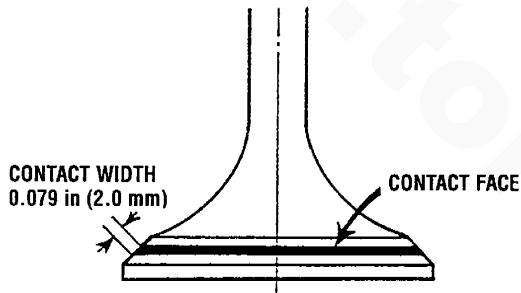

e. Check if the valve seat contact face contacts the center position of the valve contact face. If the contact position is not centered, recut and surface the valve seat and valve.

4. **Stem Wear Inspection.** If the valve stem is bent or its diameter is less than the limit, replace the valve.

Stem diameter limit	Intake	0.351 in (8.904 mm)
	Exhaust	0.350 in (8.884 mm)

VALVE SEAT

1. **Valve Seat Angle.** Valve seat angle is 45° and 30° respectively for intake and exhaust sides. The standard contact width of the valve seat is 0.079 in (2.0 mm) for both intake and exhaust sides. If the valve margin is less than the permissible limit, replace the valve.
2. **Refacing the Valve and Valve Seat.** Reface in the following order:
 - a. Reface the valve with a valve grinder to the specified angle.
 - b. Reface the valve seat with a valve seat cutter while checking the contact between the valve and the valve seat.

NOTE: Reface the valve seat taking care that the valve seat contacts the center position of the valve.

Valve Seat Angle	45° Intake, 30° Exhaust
Valve Seat Width	0.079in (2.0mm) Intake and Exhaust

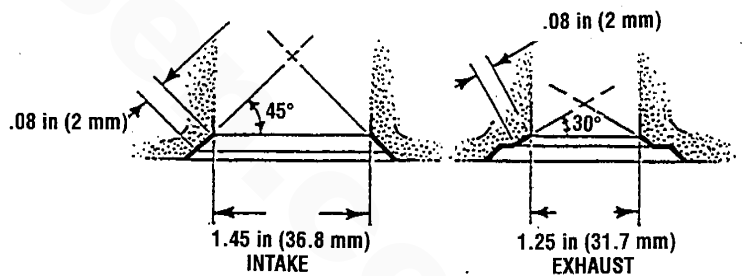

- c. Reface the valve and valve seat with a valve tapping compound.
- d. Remeasure dimension "L".
- e. Adjust dimension "L" to the standard by adding some washers between the lower spring seat and cylinder head.



ENGINE INSPECTION

ROCKER ARM

- Visual Inspection.** Check each component part of the rocker arm assembly for cracks or other damage. Check if the oil passages of the rocker arm and shaft are clogging and, if necessary, repair or replace the rocker arm.

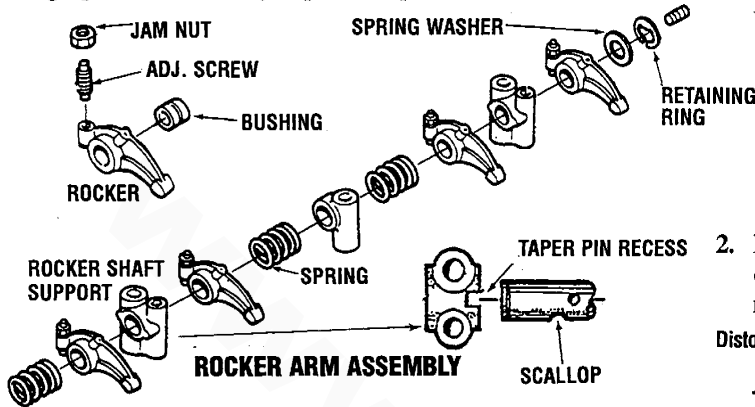

- Inspecting clearance between rocker arm and shaft.** Check the clearance between the rocker arm and shaft and, if it exceeds the limit, replace the rocker arm bushing or shaft.

Clearance Standard 0.0006 - 0.0024 in (0.016 - 0.061mm)
Limit 0.0028 in (0.07mm)

- Rocker Arm Bushing Replacement.** Using a suitable mandrel and press, press out the old bushing. Aligning the oil passages of the rocker arm bushing, press the new bushing into the rocker arm. After the rocker arm bushing has been replaced, ream the bushing bore with a spiral expansion reamer so that the clearance between the bushing and shaft becomes equal to the standard clearance.

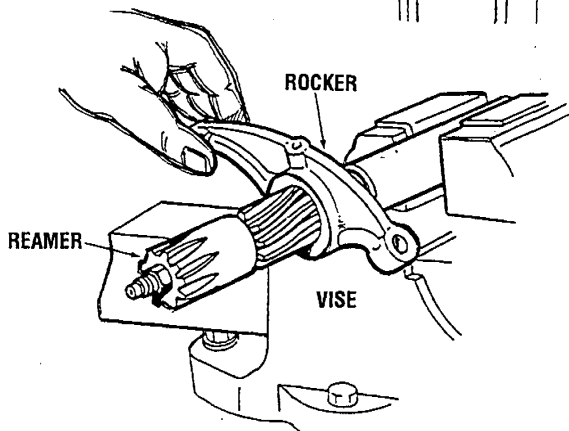
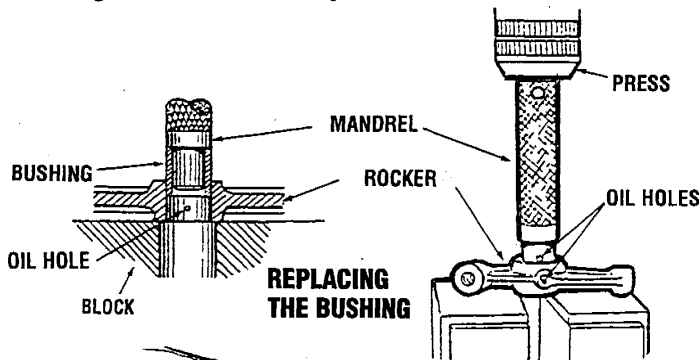

CYLINDER BLOCK

- Visual Inspection.** Check the cylinder block for cracks and damage. If necessary, repair or replace it entirely. Check to see that oil or cooling water passages are not clogged and, if clogged, remove with compressed air or a wire probe.

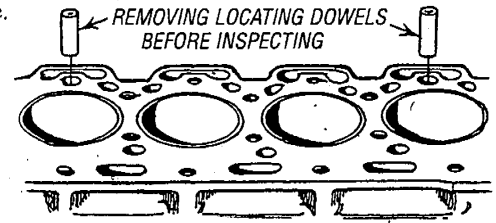

- Distortion Inspection.** Check the gasket face distortion of the cylinder block and if it exceeds the limit, repair or replace it.

Distortion limit: 1, 2 0.004 in (0.10mm)
3, 4, 5, 6 0.010 in (0.25mm)

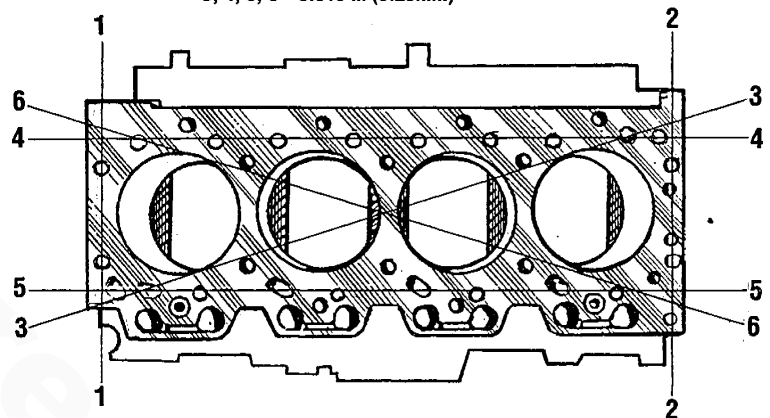

CYLINDER LINER

- Wear Inspection.** Measure the liner bore at three positions of upper, middle and lower portions with a cylinder gauge in X-X and Y-Y directions as shown. If wearing exceeds the limit, replace the liner.

Cylinder Liner Bore 3.7412 - 3.7422 in (95.025 - 95.050mm)
Wear Limit 0.008 in (0.20 mm)

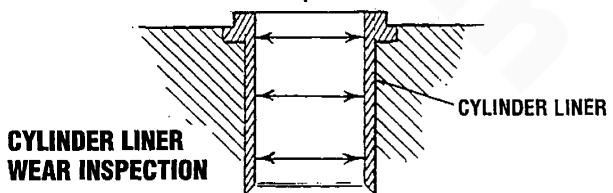
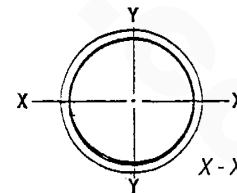

ENGINE INSPECTION

2. **Cylinder Liner Replacement.** Hydraulic press or similar device is needed.

- a. Attach the cylinder liner puller and installer to the lower rim of the cylinder liner, then press out the liner.
- b. Check for scratches on the cylinder block side and, if any, remove them by using extremely fine emery paper with engine oil.
- c. To install the liner, apply engine oil on the cylinder block bore and the liner exterior, then set the liner on the cylinder block. Using the cylinder liner puller and installer, press the liner into the cylinder block.

NOTE: Press the liner in straight. When press fitting the liner, keep the pressure within a range of 2,200-6,600lb.

Measure the liner protrusion and correct it if necessary.

Protrusion Limits 0.0040 - 0 in (0.101 - 0 mm)

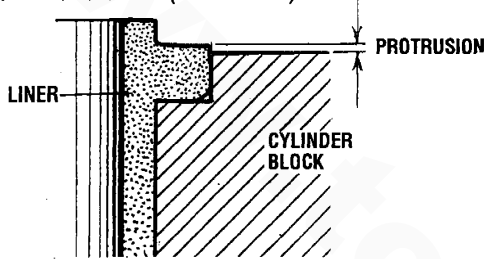

PISTON AND PISTON RING

1. **Visual Inspection.** Check the sliding surface and ring groove of the piston for wear, scratches or any other damage.

- a. Inspecting the clearance between the piston and the cylinder liner.
- b. Check the clearance between the piston and the cylinder liner by measuring the cylinder bore and the piston diameter and, if the clearance exceeds the limit, replace the cylinder liner and the piston.

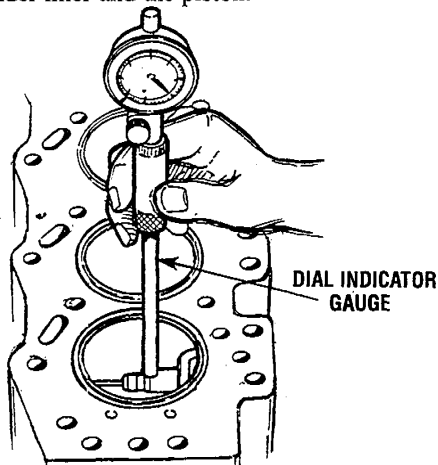

Side Clearance 0.0017 - 0.0028 in (0.032 - 0.083 mm)

c. Measure the piston diameter at 90° (perpendicular) to the pin bore axis and 0.866in (22mm) below the piston top.

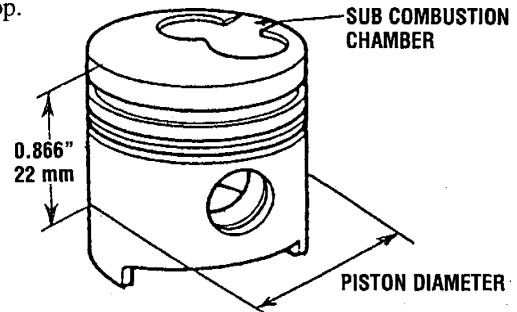

Standard Piston Diameter 3.7381 - 3.7399 in (94.967 - 94.993mm)

2. **Piston Ring Inspection.** Check the piston ring for breaks, seizure and wear and, if any of these conditions exist, replace the ring. Check the clearance between the piston ring and the ring groove and, if it exceeds the limit, replace the ring.

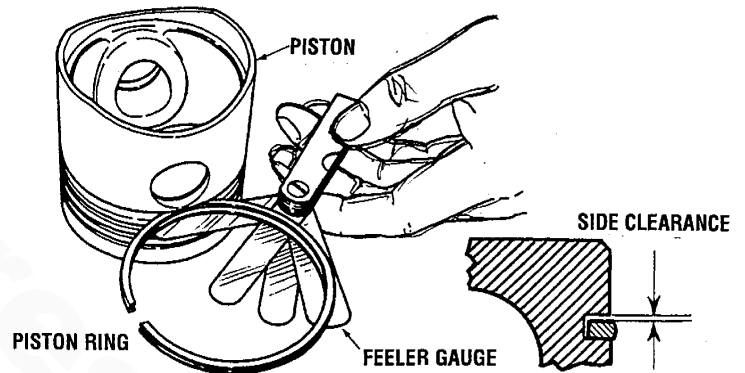

Side Clearance Limit 0.012 in (0.30mm)

3. **Inspecting the piston ring end gap.** Position the piston ring into the bottom of the cylinder liner. Measure the piston ring end gap and, if it exceeds the limit, replace the ring. Be sure to position the piston ring below the ring sliding surface of the cylinder liner.

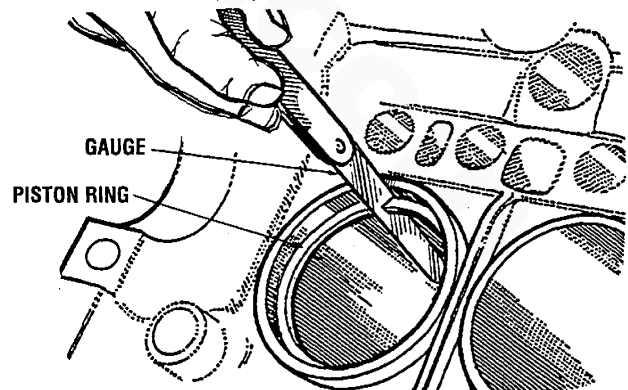

Piston Ring End Gap Limit 0.591 in (1.5mm)



ENGINE INSPECTION

CONNECTING ROD

1. **Visual Inspection.** Check the connecting rod for cracks or other damage and, if necessary, replace it.

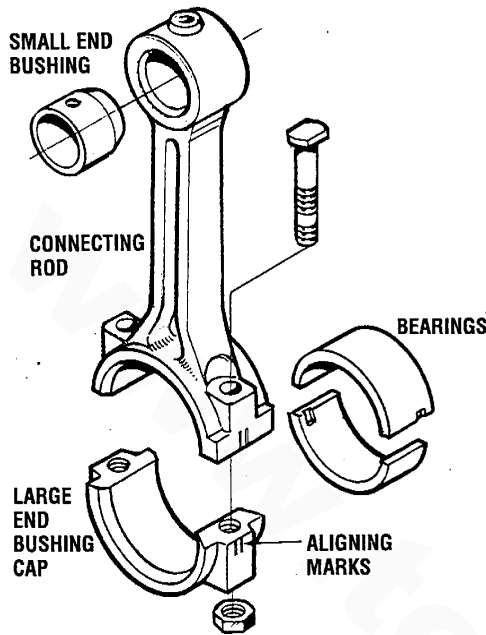

2. **Bend Inspection.** Using a connecting rod aligner, check the bend and twist of the connecting rod and, if exceeding the limit, repair it with a press or replace it.

Bend Limit 0.002 in per 3.9 in (0.05 mm per 100 mm)

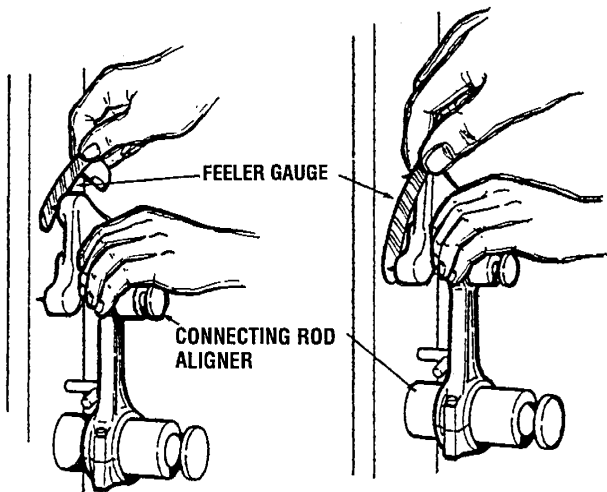

3. **Inspect the clearance between the piston pin and small end bushing.** Check the clearance between the piston pin and the small end bushing and, if it exceeds the limit, replace the piston pin or small bushing.

Clearance Standard: 0.0005 - 0.0015 in (0.012 - 0.039 mm)
 Clearance Limit: 0.002 in (0.05 mm)

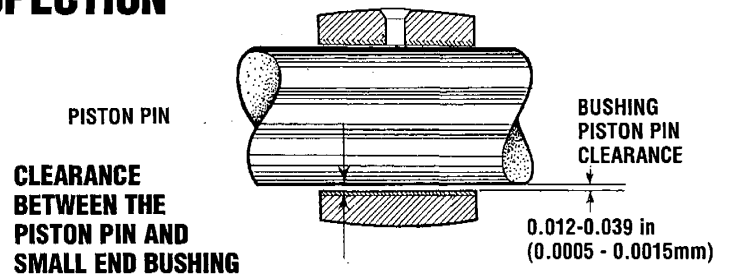

4. **Small end bushing replacement.** Using a press, press out the old bushing. Align the oil passages of the connecting rod and the small end bushing; press in the new bushing to the connecting rod bore. After a small end bushing has been replaced, ream the bushing bore to obtain the specified clearance between the small end bushing and the piston pin.

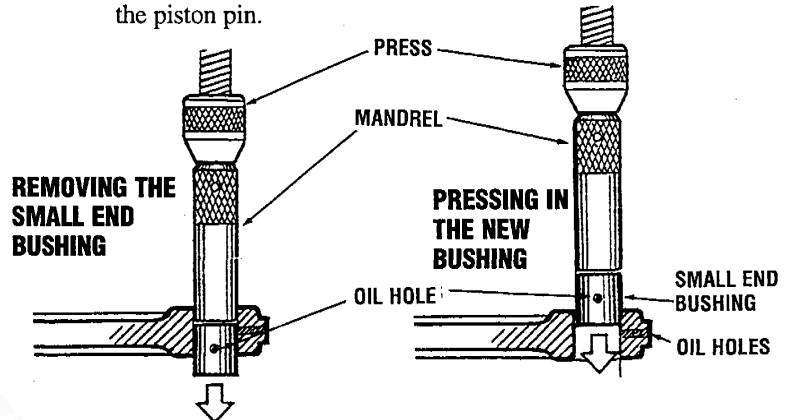

NOTE: When reaming the bushing, correctly insert the reamer in the bushing. In order to prevent unevenness on the bushing surface, the reaming should always be made in the cutting direction. Make certain the reamer is stopped at different positions at all times.

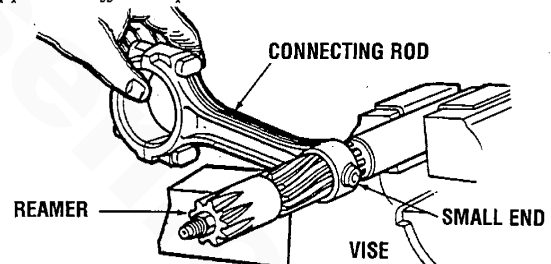

5. **Inspecting connecting rod side play.** Check the connecting rod side play with the dial gauge and, if it exceeds the limit, replace the connecting rod and crankshaft.

Side Play Limit 0.016 in (0.40 mm)

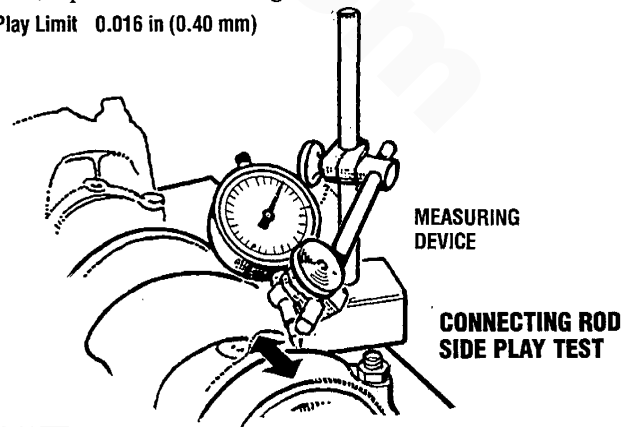

ENGINE INSPECTION

- Inspecting connecting rod bearing.** Check the connecting rod bearing for peeling and thermal damage. If it is severe, replace the bearing.
- Inspecting connecting rod bearing clearance.** Using the plastigauge, measure the oil clearance of the connecting rod bearing and, if it exceeds the limit, replace the connecting rod bearing.

Connecting Rod Cap Torque 56.41- 57.86 ft-lb (7.8 - 8.0 m-kg)

Connecting Rod Bearing Clearance

Standard: 0.0005 - 0.0012 in (0.012 - 0.031 mm)
Limit: 0.0020 in (0.05mm)

Undersize Bearing: 0.010 in (0.254 mm)
0.020 in (0.508 mm)
0.030 in (0.762 mm)

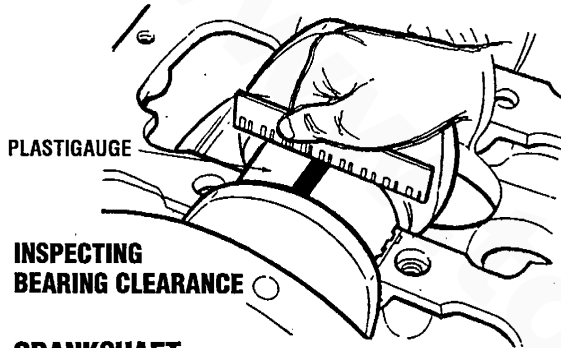

INSPECTING BEARING CLEARANCE

CRANKSHAFT

- Visual Inspection.** Check the crankshaft for cracks or other damage. If cracking is suspected, thoroughly clean the crankshaft and perform a magnaflux check of the crankshaft. If any cracks are detected, replace the crankshaft.

MAGNAFLUX TEST

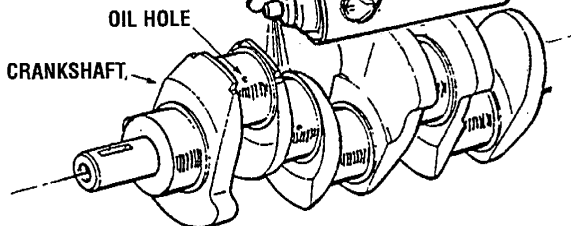

Check for clogging of oil passages and, if clogged, remove with compressed air or a wire.

- Runout inspection.** Check the crankshaft runout and, if it exceeds the limit, replace the crankshaft.

Runout Limit 0.0020 in (0.05 mm)

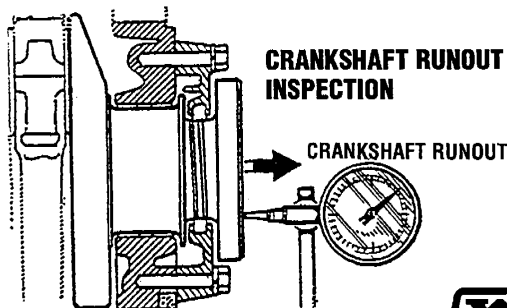

- Inspecting crank pin and journal.** Support the crankshaft on both ends using V-blocks. Measure the diameter of each crank pin and crankshaft main journal and, if the diameter is less than the limit, refinish the crank pin and main journal to size for the next undersize bearing.

Crank pin diameter

Standard 2.40601 - 2.4065 in (61.112 - 61.125 mm)
Wear limit 0.002 in (0.05 mm)

Main journal diameter

Standard 2.9848 - 2.9853 in (75.812 - 75.825 mm)
Wear limit 0.002 in (0.05 mm)

- For the measurement on both the crank pin and the main journal, measure them at vertical and horizontal directions on front and rear places.
- When refinishing the crankshaft, it's finish to R1mm as shown in the diagram.
- Refer to the chart for refinishing dimensions of the crankshaft where an undersize bearing is used.

REFINISHING DIMENSIONS

Undersize bearing	Main journal diameter
0.01 in (0.254 mm)	2.9748 - 2.9753 in (75.558 - 75.571 mm)
0.02 in (0.508 mm)	2.9648 - 2.9675 in (75.304 - 75.317 mm)
0.03 in (0.762 mm)	2.9578 - 2.9554 in (75.050 - 675.063 mm)

Undersize bearing	Crankpin diameter
0.01 in (0.254 mm)	2.3964 - 2.3965 in (60.868 - 60.871 mm)
0.02 in (0.508 mm)	2.3874 - 2.3865 in (60.604 - 60.617 mm)
0.03 in (0.762 mm)	2.3760 - 2.3765 in (60.350 - 60.363 mm)

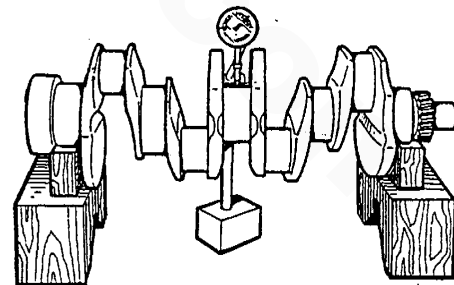
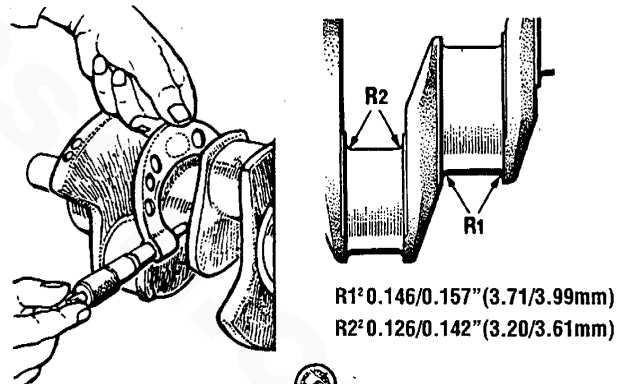

ENGINE INSPECTION

4. **Inspecting crankshaft end play.** Check the end play of the crankshaft and, if the end play exceeds the limit, replace the thrust washer with 0.007 in (0.178 mm) over-size. Crankshaft end play is measured by setting a dial gauge on the rear end of the crankshaft and moving the crankshaft in the axial direction.

Crankshaft End Play Standard: 0.0055 - 0.0154 in (0.14 - 0.39 mm)
Crankshaft End play limit: 0.0157 in (0.40 mm)

MAIN BEARING

1. **Inspecting main bearing.** Check the main bearing for peeling, seizure or fusion and, if necessary, replace the bearing.
2. **Inspecting main bearing clearance,** Using the plastigauge, measure the oil clearance and, if it exceeds the limit, replace the main bearing.

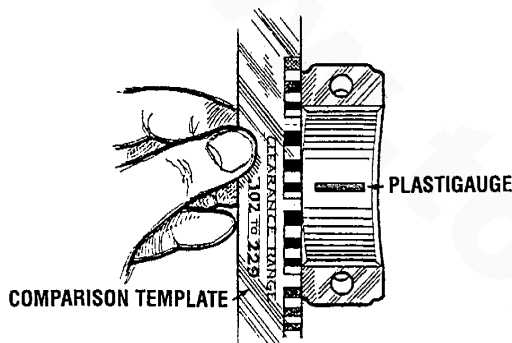

Oil Clearance Standard: 0.0023 - 0.0035 in (0.059 - 0.090 mm)
Oil Clearance Limit: 0.005 in (0.12 mm)

CAMSHAFT

1. **Visual Inspection.** Check the camshaft for cracks and damage. If necessary, replace the camshaft.
NOTE: If the damage is slight, you may be able to correct the camshaft with an oil soaked fine emery grindstone. Take special care to not damage the original cam form.
2. **Inspecting cam height.** Measure the cam height and, if it is less than the limit, replace the camshaft.

Cam height limit: 1.6724 in (42.478 mm)

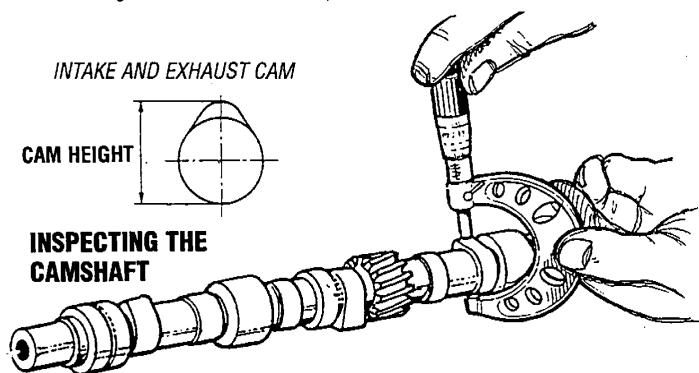

3. **Inspecting camshaft journal.** Check the camshaft journal and, if wearing exceeds the limit, replace the camshaft.

	Diameter of Journal	Wear Limit
No. 1	2.0437 - 2.0449 in (51.910 - 51.940 mm)	0.008 mm
No. 2	2.0339 - 2.0350 in (51.660 - 51.690 mm)	(0.0003 in)
No. 3	2.0240 - 2.0252 in (51.410 - 51.440 mm)	
No. 4	2.0142 - 2.0154 in (51.160 - 51.190 mm)	

4. **Inspecting camshaft oil clearance.** Check the clearance between the camshaft journal and the camshaft support bore as follows:
 - a. Measure the camshaft journal diameter and the camshaft support bore.
 - b. Calculate the clearance and replace the camshaft or cylinder block if the clearance exceeds the limit.

Oil clearance limit 0.0057 in (0.145 mm)

5. **Checking camshaft alignment,** and, if it exceeds the limit, replace the camshaft.

Maximum allowable runout 0.0031 in (0.08 mm)

6. **Inspecting camshaft end play.**
 - a. Install the thrust plate, camshaft gear, friction gear, lock plate and camshaft gear lock bolt on the camshaft.
 - b. Tighten the lock bolt to the specified torque.

Lock Bolt Torque (19mm socket) 46 - 69 lb/ft (6.4 - 9.5 kg/m)

- c. Measure the clearance between the thrust plate and camshaft gear. If it exceeds the limit, replace the thrust plate.

End play limit 0.0118 in (0.3 mm)

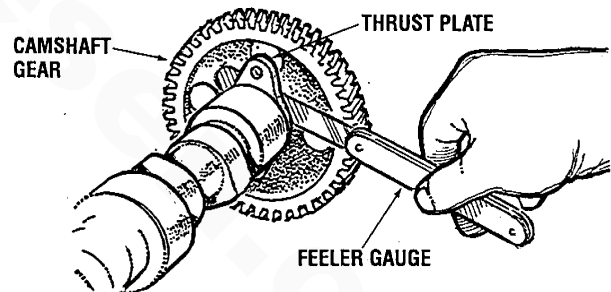

IDLER GEAR BUSHING AND IDLER GEAR SPINDLE

1. **Visual inspection.** Check for damage on the bushing inner surface of the idler gear and the spindle sliding surface and, if necessary, replace the idler gear or spindle. Check the oil passage for clogging and, if necessary, clean the passage with compressed air or wire.
2. **Inspecting clearance between bushing and spindle.** Check the clearance between the idler gear bushing and the spindle and, if it exceeds the limit, replace the idler gear or spindle.

Clearance Standard: 0.0013 - 0.0033 in (0.034 - 0.084 mm)
Clearance Limit: 0.006 in (0.15 mm)

ENGINE INSPECTION

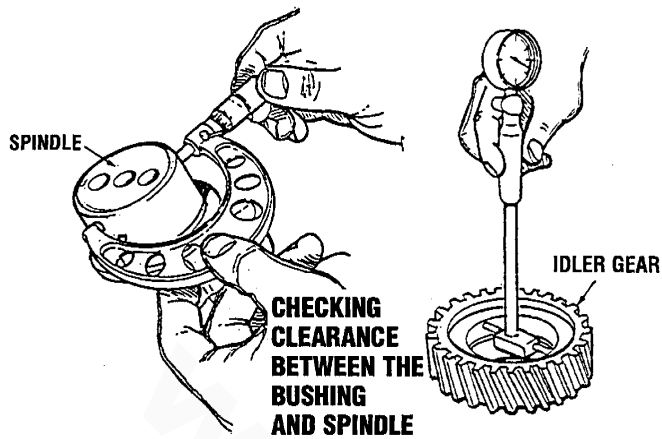

CHECKING THE GEARS

1. **Visual Inspection.** Check each gear (idler gears, injection pump drive gear, crankshaft gear, camshaft gear) for cracks or other damage. If necessary, replace as required.
2. **Inspecting end play of idler gear.** Check the end play of the idler gear with a dial indicator as shown. If it exceeds the specified limit, replace the thrust plate or idler gear.

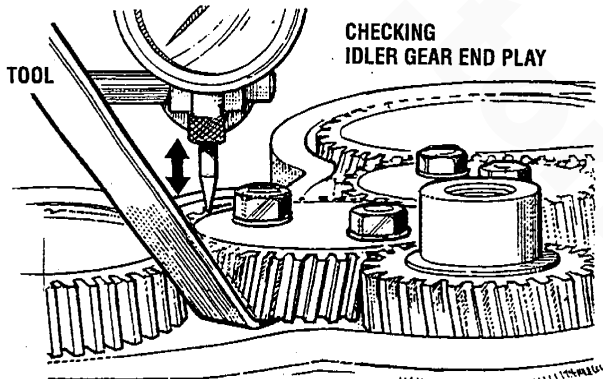

NOTE: Measure the end play after tightening the idler gear attaching nuts to the specified torque value.

Thrust plate torque (1/2" socket) 17 - 23 ft-lb (2.3 - 3.2 kg/m)
Standard end play 0.0059 - 0.0118 in (0.15 - 0.30 mm)

3. **Check backlash between gears.** Check the backlash between each gear with a dial indicator.

NOTE: Check the backlash after assuring that the idler gear end play and the clearance between the idle gear bushing and spindle are within the standard.

Backlash Standard 0.0039 - 0.0079 in (0.10 - 0.20 mm)
Backlash Limit 0.0118 in (0.30 mm)

TAPPET

1. **Visual inspection.** Check the tappet for cracks and other damage and, if damaged replace the tappet. Check for abnormal wear of the portion of the tappets that contact with the cam, and if any one is abnormally worn, replace the tappet.
2. **Inspecting Clearance Between Tappet and Tappet Bore.** Check the clearance between the tappet and tappet bore and, if the clearance is greater than the limit, replace the tappet or cylinder block.

Clearance Limit 0.0039 in (0.10 mm)

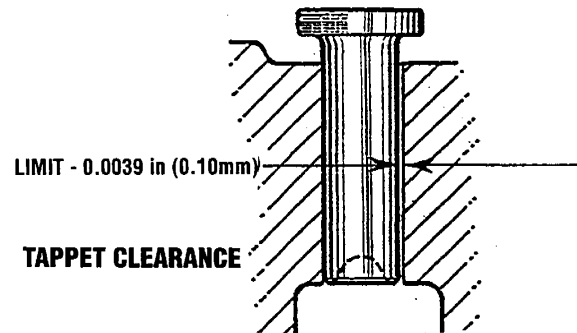

PUSH RODS

1. **Visual Inspection.** Check each push rod for damage to either end. If damage is severe, replace the push rod.
2. **Bend Inspection.** Check the push rod for bend and, if it exceeds the limit, replace it. Place the push rod on a flat surface and measure the clearance between the center of the push rod and the flat surface. Replace the push rod if the wear limit is exceeded.

Bend limit: 0.0075 in (0.19 mm)

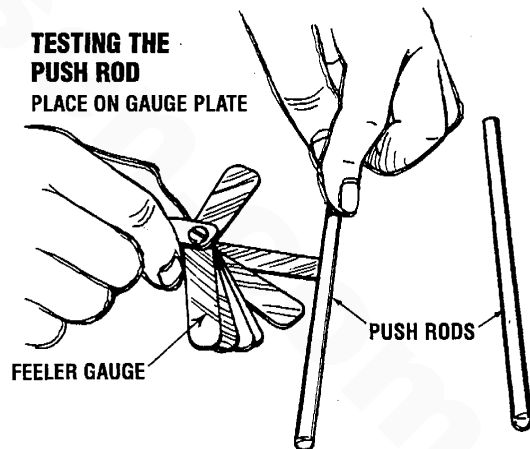

TIMING GEAR COVER OIL SEAL

1. **Inspecting timing gear cover oil seal.** Check the timing gear cover and the lip of the oil seal for any damage. If necessary, replace the cover or oil seal.
2. **Oil seal replacement.** To remove the oil seal, use the oil seal puller and installer and pull out the oil seal. To install, apply engine oil on the outside of a new oil seal, then press fit the oil seal with oil seal puller and installer until the installer comes in contact with the cover.

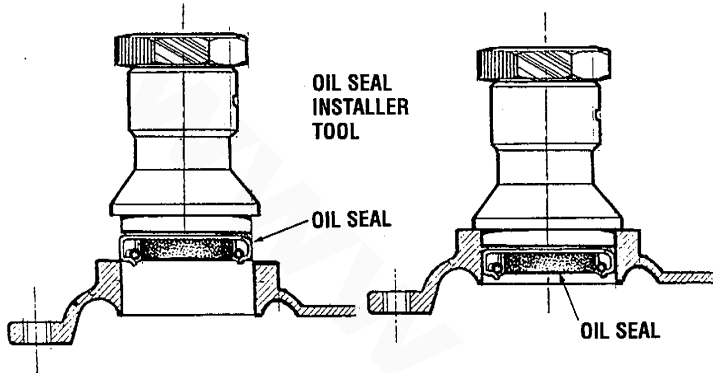

REAR OIL SEAL

1. **Inspecting oil seal.** Check the oil seal lip for wear, fraying or other damage and, if necessary, replace it.
2. **Oil seal replacement.**
 - a. Strike out the old rear oil seal with a suitable mandrel.
 - b. Apply engine oil onto the outside of a new seal and press fit the seal in the rear oil seal cap equally.

NOTE: In case the crankshaft is worn, the oil seal must be fitted on the oil seal cap with its fitting position moved by approximately 0.1181in (3mm) so that the seal does not touch the worn down portion of the crankshaft.

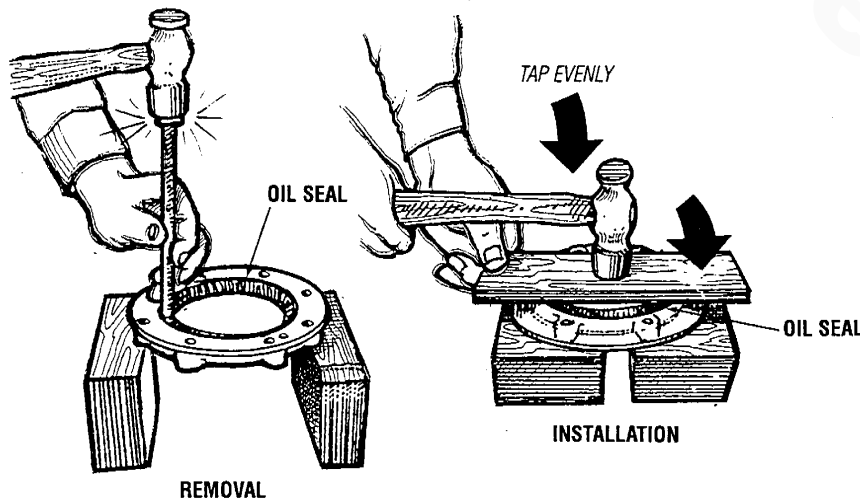

OIL PAN

1. Scrape and clean any dirt or metal particles from the inside of the oil pan.
2. Check the oil pan for cracks and damaged drain plug threads
3. Inspect for damage (uneven surface) at the bolt holes caused by the over torquing of the bolts. surfaces as required. Repair or replace the oil pan.

OIL JET (UPPER BLOCK)

1. Make certain the oil passage is not clogged.
2. Inspect the spring in the oil jet valve for damage and sticking.

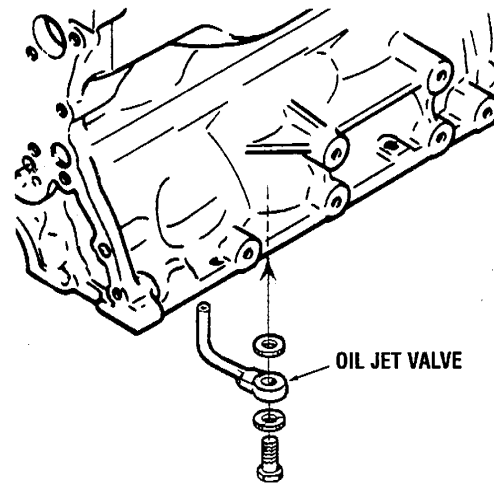

ENGINE ASSEMBLY

Reassembly Precautions

- Be careful not to mix bolts and nuts. Metric and S.A.E. bolts are used on various engine assemblies.
- During assembly, recheck clearances and insure that parts are being assembled in their proper order and facing in the correct direction in relation to the engine block, such as, pistons, piston rings, bearings and bearing caps.
- Apply lubricating oil to moving parts during assembly. Insure that moving parts, when assembled on the engine, rotate or slide and are not subject to binding or excessive tension.
- If there are mating marks scribed during disassembly, reference them correctly for assembly.
- Use new gaskets, lockwashers, O-rings, etc.
- Tighten the bolts and nuts on important parts of engine to specified torques using a reliable torque wrench.
- Use liquid sealants when required on nuts, bolts and gaskets. Refrain from using tape sealants.

NOTE: Also refer to *Sealants and Lubricants* in this manual.

Be aware of these common problems that can occur during assembly.

Insufficient Lubrication. Heavily oil sliding and reciprocating parts, lightly oil head bolts and other fasteners, except those that penetrate into the water jacket. These fasteners should be sealed with Permatex No. 2 or the high-tack equivalent.

Reversed orientation. Most gaskets, many bolt washers, and all thermostats are asymmetrical.

Mechanical damage. Run fasteners down in approved torque sequences and in three steps—1/2, 2/3, and 1/1 torque. Exceptions are torque-to-yield bolts and rocker arm shaft fasteners. The former are torqued as indicated. The latter—rocker shaft fasteners—should be brought down in very small increments, working from the center bolts out. Gaskets, especially head gaskets, might be damaged during assembly, they should be positioned with great care.

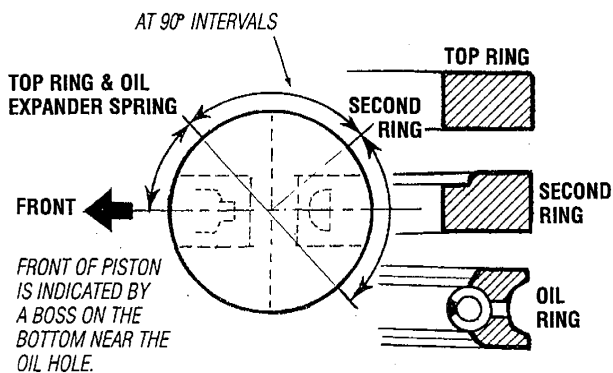

ENGINE ASSEMBLY

1. **Install the valves in cylinder head.** Using the valve spring lifter arm and pivot, assemble the valve, lower spring seat, oil deflector, inner valve spring, outer valve spring, upper spring seat and taper sleeve in this order.

NOTE: The oil deflector should be installed on the intake valve only.

2. **Assemble the rocker arm shaft, rocker shaft brackets and rocker arms.** Note that the front end of the rocker shaft is identified by a pin protruding from the top and a larger oil hole between the supply holes serving #1 and #2 rocker arms. This pin fits a slot in the #1 rocker shaft support which prevents the shaft from turning and cutting off the lube oil to the rocker arms and valves. Use the following order of assembly:

- | | |
|-------------------------|----------------|
| a. Spring | d. Rocker |
| b. Rocker | e. Wave washer |
| c. Rocker shaft support | f. snap ring |

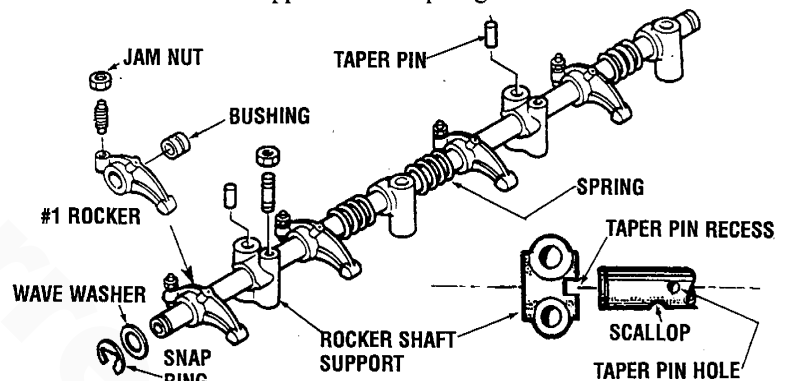

3. **Assemble the connecting rod, piston and piston rings.** Arrange the piston and the connecting rod as shown and, using the piston pin installer, insert the piston pin through the piston and connecting rod until the piston pin (wrist pin) snap rings can be fitted. Fit the piston pin snap rings to their respective grooves. Install the piston rings to ring grooves on the piston with the inscription mark on ring upward using a suitable piston ring expander.

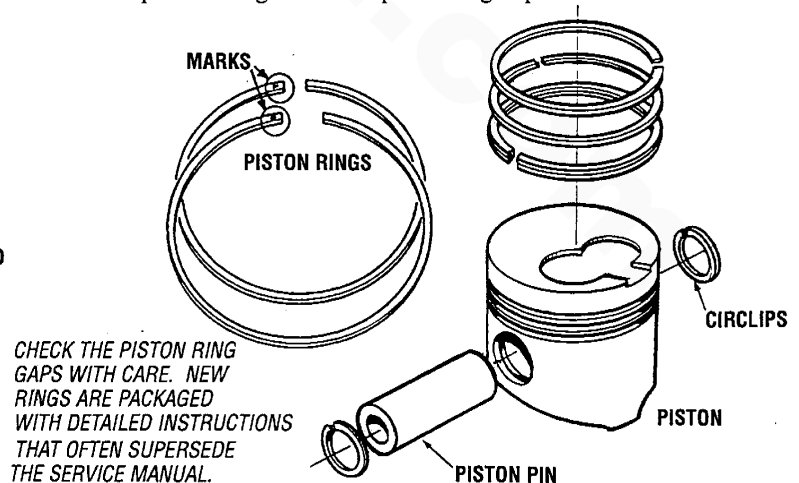

ENGINE ASSEMBLY

4. Main Bearings and Bearing Caps.

NOTE: Do not apply oil to the backsides of the main bearing shells.

- a. Fit the main bearings on the cylinder block and the bearing caps respectively. Check that the oil ways align perfectly with those in the block.
- b. Fit the thrustwashers to the cylinder block so that the oil grooves on thrustwashers face to crankshaft side.
- c. Position the crankshaft to the cylinder block, being careful not to drop the thrustwashers as the crankshaft settles into place.

FITTING THE THRUST WASHERS
ALIGN THE OIL HOLES

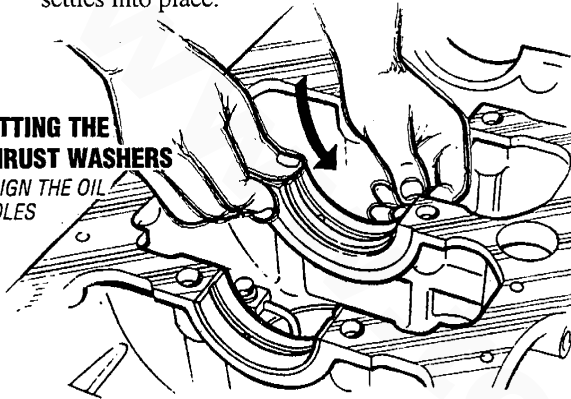

- d. Fit the thrust washer to the main bearing cap so that the oil grooves on thrust washer face to crankshaft side. Then install the main bearing cap to the cylinder block with arrow mark of the main bearing cap facing the crankshaft pulley side.

Main Bearing Cap Torque 11.0 - 11.7 m-kG (80 - 85 ft-lb)

FITTING THE BEARING CAPS

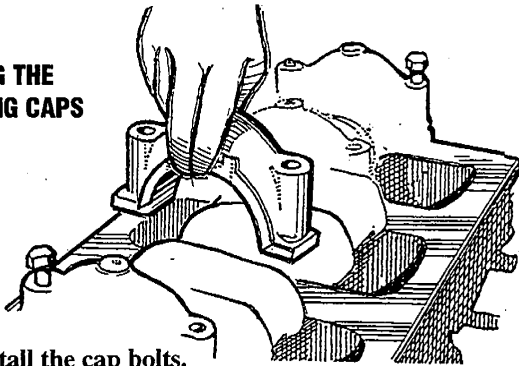

5. Install the cap bolts.

NOTE: Ensure the crankshaft rotates smoothly after installing.

6. Install the rear oil seal. Apply oil to the oil seal lip.
7. Install the piston and connecting rod assembly.
 - a. Place the piston rings so that the ring ends are properly spaced around the circumference of the piston as shown on the previous page.
 - b. Using a ring compressor, fit the piston into the cylinder in the position as is shown. Apply oil onto the sliding face of the piston and the cylinder bore.

PLACE A HEAVY HAMMER AND GENTLY PRESS DOWN WITH THE FORCE OF YOUR HAND. THE ENTIRE SURFACE SHOULD BE COATED WITH FRESH LUBE OIL.

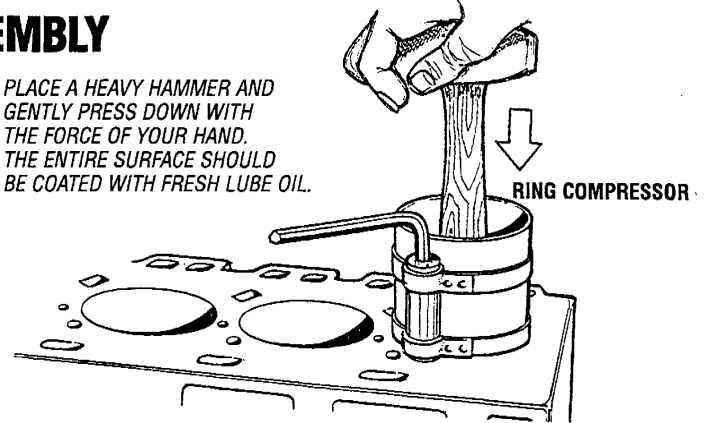

- c. Install the caps to the connecting rods, ensuring that the identification numbers on the cap and connecting rod are matched.

Cap Torque (14 mm socket) 59 - 65 ft-lb (8.2 - 9.0m-kG)
(install new connecting rod bolts)

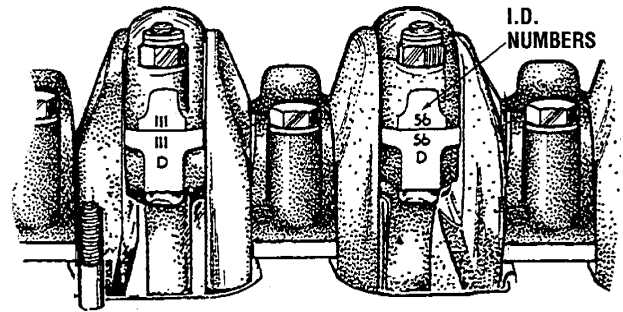

8. Installation of the crankshaft.

- a. Insert the tappets into the cylinder block. Apply engine oil to the sliding face of the tappet.

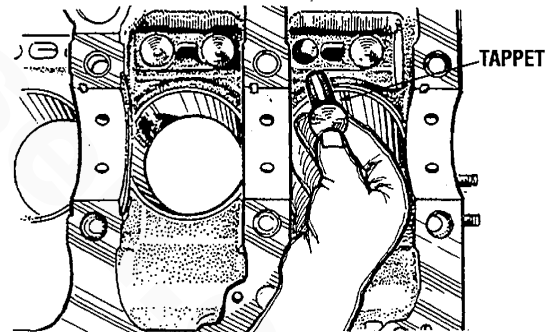

- b. Insert the camshaft into the cylinder block. Apply oil to the camshaft journal and bearing surfaces.

- c. Install the camshaft thrust plate.

Thrust Plate Torque (1/2 in socket) 11.6 - 17.4 ft-lb (1.6 - 2.4 m-kG)

9. Install the idler gear spindle. Align the oil passages of the idler gear spindle and cylinder block.

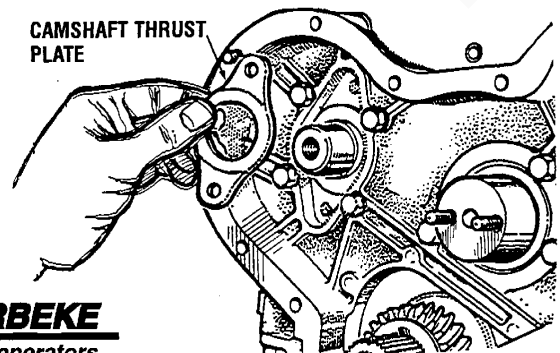

10. Fuel Injection Pump.

NOTE: It is easier to first install the injection pump to the timing gear case and the entire assembly onto the engine. Install the injection pump aligning the identification marks.

Mount the injection pump on the gear case, then tighten the pump drive gear attaching nuts.

Attaching Nut Torque 29 - 51 ft/lb (4.0 - 7.0 m/kg)

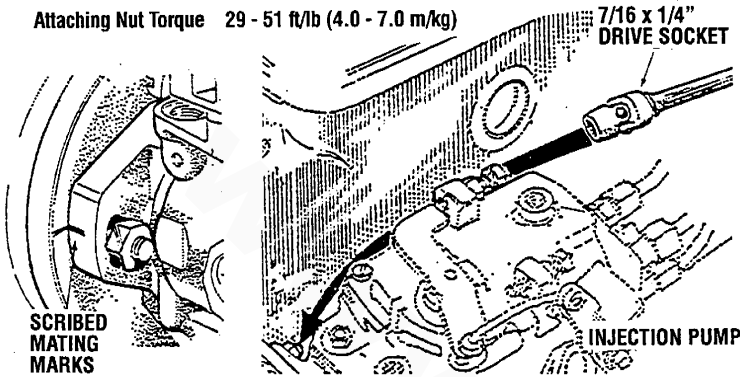

11. Install the timing gear case. Attach the straight edge on the cylinder block, then match the surfaces of the timing gear case end and that of the cylinder block. If the gasket protrudes from the mating surface, cut away the excess with a knife.

Attaching Bolt Torque (1/2 in socket) 12 - 17 ft/lb (1.6 - 2.4 m/kg)

12. Install each gear. While aligning the timing mark of each gear, install the following gears on each position:

- a. Camshaft gear;
- b. Idler gears;
- c. Injection pump drive gear;
- d. Install the idler gear thrust plate, then tighten the nuts.

Idler Gear Thrust Plate
 Nut Torque (1/2 in socket) 16.6 - 23.1 ft-lb (2.3 - 3.2 m/kg)

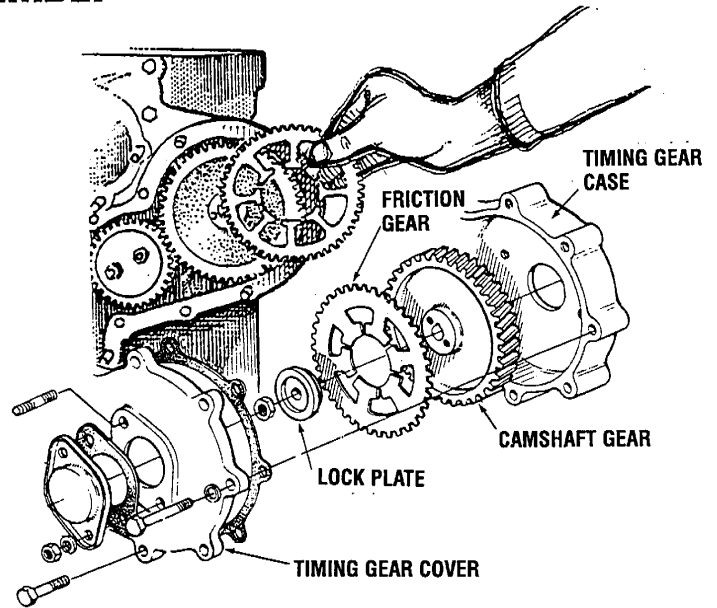
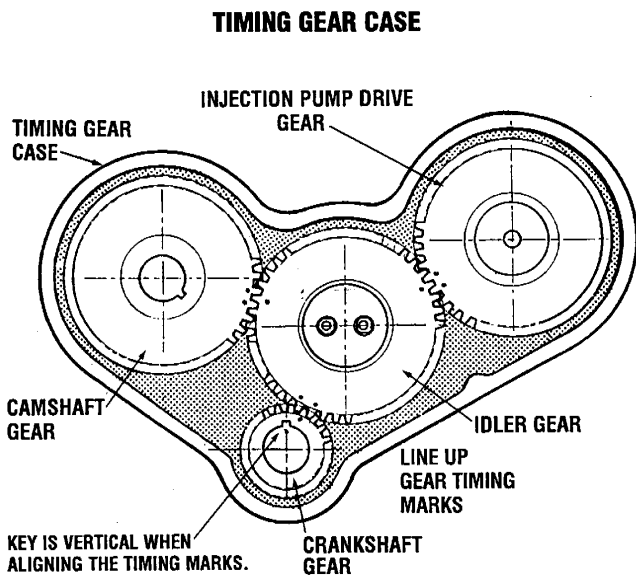

13. Install the friction gear.

14. Install the camshaft gear lock bolt.

NOTE: Wedge a clean cloth between the camshaft gear and the idler gear.

Lock Bolt Torque (19 mm socket) 46 - 69 ft-lb (6.4 - 9.5 m/kg)

15. Install the injection pump drive gear lock nut.

NOTE: Wedge a clean cloth between the injection pump drive gear and the idler gear.

Lock Bolt Torque (1 in socket) 29 - 51 ft-lb (4.0 - 7.0 m/kg)

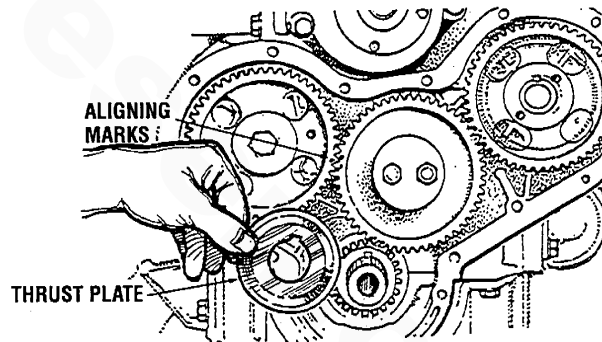

16. Install the oil deflector on the crankshaft.

17. Install the timing gear cover.

- a. Install the bearing housing cover on the timing gear cover.
- b. Install the injection pump drive gear cover on the timing gear cover.
- c. Install the timing gear cover and tighten the timing gear cover attaching nuts and bolts after the crankshaft pulley has been installed temporarily to center the seal.

Timing Gear Cover Torque 11.6 - 17.4 ft-lb (1.6 - 2.4 m/kg)

18. Mount the oil pump assembly. Apply the sealing agent on the set screw thread and tighten the screw. Ensure the oil pump drive gear and the driven gear mesh.

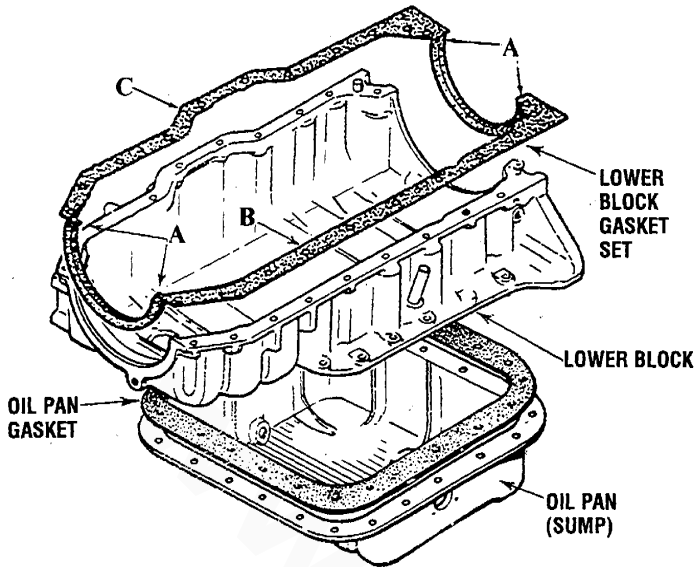

19. Assemble the new gasket set (lower block).

- Position the gasket ends A on the gaskets B and C.
- Apply a silicon sealing agent on the mating surfaces of the gasket and that between the cylinder block and the timing gear case.
- Install the lower block making certain the lower block gasket is perfectly aligned. Tighten the bolts evenly.

Lower block Bolt Torque (1/2 in socket) 12 - 17 ft-lb (1.6 - 2.3 m-kg)

20. Install the oil pan gasket and the oil pan (sump).

Oil Pan Bolts Torque (9/16 in socket) 12 - 17 ft-lb (1.6 - 2.3 m-kg)

21. Attach the back plate.

Back Plate Torque (9/16 in socket) 23.9 - 35 ft-lb (3.3 - 4.8 m-kg)

22. Install the flywheel. Install the flywheel onto the rear end of the crankshaft by placing it on the crankshaft and rotating it to properly align the mounting bolt holes. Install the tabwasher and the attaching bolts. After torquing, bend one tab against the flat of each attaching bolt.

Flywheel Bolts Torque (19 mm socket) 112 ft-lb (15.5 m-kg)

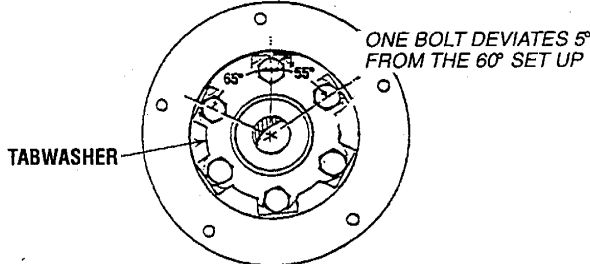

23. Install the raw water pump. Mount the raw water pump on its adapter plate and assemble it to the engine. Do not tighten.

24. Install the crankshaft pulley. Apply engine oil onto the lip of the oil seal. Carefully slide the front crankshaft pulley onto the crankshaft ensuring that the key in the crankshaft and the keyway in the pulley mate properly. Apply Loctite (high temperature) to the threads of the front crankshaft pulley holddown bolt when installing it. Ensure the flat washer is under the head of the bolt.

Front Crankshaft Pulley

Bolt Torque (38 mm socket) 253 - 289 ft-lb (30 - 40 m-kg)

25. Install the two tubular dowels adjacent to cylinders 1 and 4 if they were removed earlier during disassembly. Position the gasket on cylinder block. Do not use any liquid seal or cement.

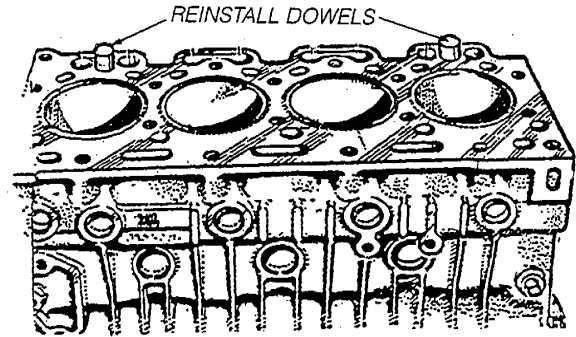

26. Position the cylinder head.

27. Insert the pushrod. Check if the push rod is securely set in the tappet concavity.

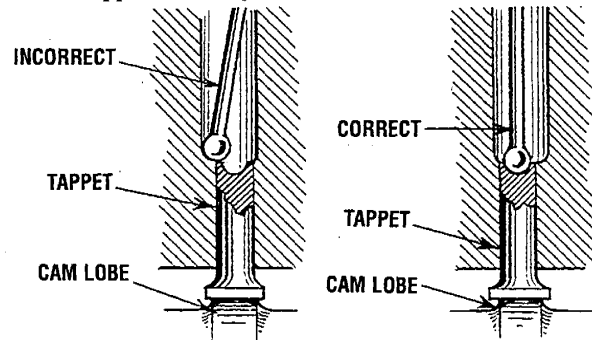

28. Position the valve cap on the top of the valve stem. It should be set squarely on the valve stem.

29. Install the rocker arm assembly onto the cylinder head. Remember that the end of the rocker shaft having the pin occupying the slot in #1 rocker support points toward the front (pulley) end of the engine.

30. Tighten the cylinder head bolts. Tighten the cylinder head bolts evenly in the sequence shown. After tightening the cylinder head bolts, make certain the rocker arms move smoothly.

Cylinder Head Bolts

Torque (3/4 in socket) 85 - 90 ft-lb (11.8 - 12.5 m-kg)

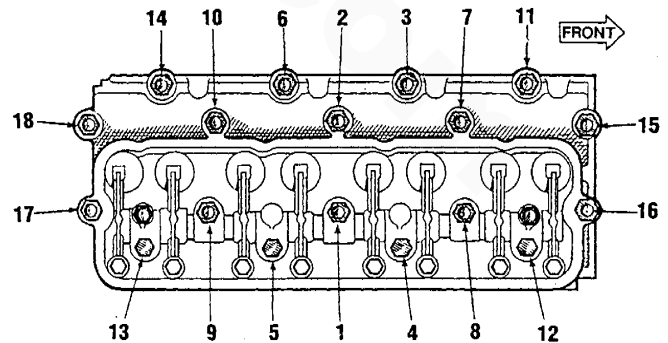

ENGINE ASSEMBLY

31. Adjust the valve clearance. Adjust the No. 1, 2, 3, and 6 valves when the No. 1 piston is on Top Dead Center (TDC) or the compression stroke.

Turn the crankshaft once, setting the No. 4 cylinder piston at TDC (compression) and adjust the No. 4, 5, 7, and 8 valves. The valves are numbered 1 - 8 from front of the engine.

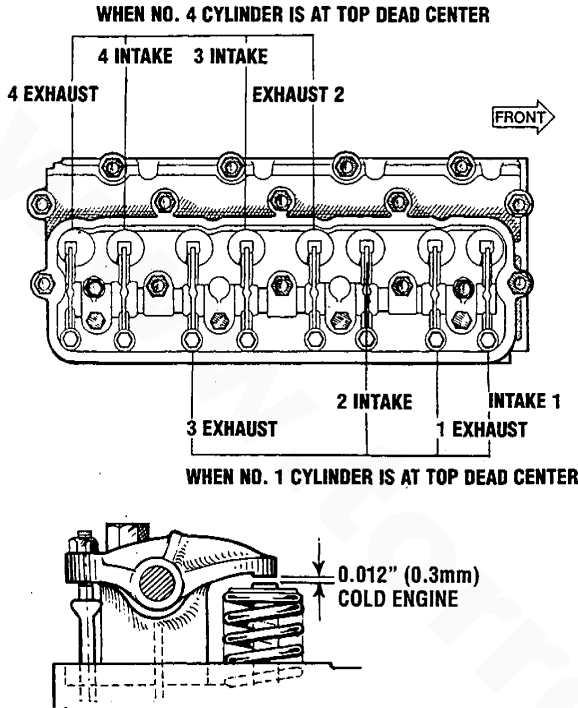

32. Adjust each valve's clearance by inserting a 0.012 in (0.03 mm) feeler gauge between the rocker arm and the valve stem.

Valve Clearance 0.30 mm (.12 in) cold

NOTE: When the engine overhaul is complete, run the engine under load to check its performance. Allow the engine to cool to room temperature and retorque the cylinder head holddown nuts and readjust valves. The cylinder head hold-down bolts and valve adjustment should be rechecked again after 50 hours and periodically thereafter.

33. Install the cylinder head cover.

Cylinder Head Cover Bolts Torque 0.3 - 0.4 m-kg (2 - 3 ft-lb)

NOTE: After the engine has been reassembled, readjust the valve clearances with a warm engine, see ENGINE ADJUSTMENTS.

34. Install the thermostat and thermostat housing.

- a. Inspect the thermostat housing and the housing gasket. Apply some sealant to the gasket when reassembling.
- b. Install the temperature switch and sender and reconnect their wires.

c. Install a new thermostat and gasket (the old thermostat can become a spare). When installing the new thermostat and gasket, apply a thin coat of sealant to both sides of the gasket.

d. The thermostat can be checked for proper operation by placing it in a pan of cold water and then raising the temperature of the water to a boil. The thermostat should open noticeably (with travel on the order of 1/4 in - 1/2 in) and be fully opened when the water is boiling.

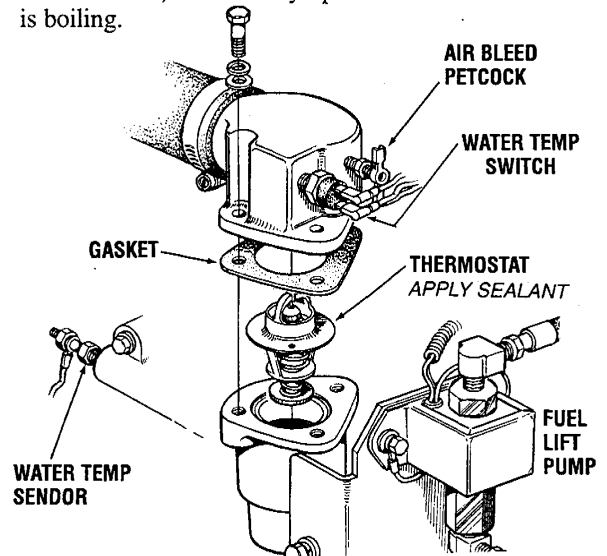

35. Attach the engine coolant circulating pump.

Coolant Pump Assembly
Bolts Torque (use 1/2" socket) 1.6 - 2.3 m-kg (12 - 17 ft-lb)

A complete breakdown of the COOLANT PUMP ASSEMBLY is covered elsewhere in this manual.

36. Adjust the injection timing.

Refer to INJECTION TIMING elsewhere in this manual.

37. Mount the oil filter bracket / oil cooler assembly.

When installing the new filter apply a thin coat of clean engine oil to the rubber gasket. Tighten by hand.

38. Mount the front engine mounting bracket.

Mounting Bracket Torque 4.6 - 6.8 m-kg (33 - 49 ft-lb)

39. Install the intake manifold. Replace the four gaskets.

Intake Manifold Torque 11.6 - 17.4 ft-lb (1.6 - 2.4 m-kg)

40. Mount the fuel filter assembly.

41. Mount the rocker arm cover using a new gasket.

Apply sealant to that portion of the gasket that contacts the gasket only.

Rocker Arm Cover Torque 2 - 3 ft-lb (0.3 - 0.4 m-kg)

42. Attach the crankcase vent hose.

43. Install the fuel injection nozzles and return lines. Use new sealing washers throughout, in the same order as were the old washers.

Injector To Head Bolt (27mm deep socket) 43 - 51 ft-lb (6.0 - 7.0 m-kg)

See *FUEL INJECTORS* for more details.

44. Install the glow plugs and connectors. Use anti-seize compound on the threads.

Glow Plug Torque 7.2 - 10.8 ft-lb (1.0 - 1.5 m-kg)

To test the glow plugs, see *GLOW PLUGS*.

45. Connect the fuel line to the engine mounted fuel filter and the injection pump. Use new sealing washers.

46. Connect the high pressure injector lines from the injection pump to injectors. Reinstall the line clamp.

Attaching Nuts Torque 18 - 22 ft-lb (2.5 - 3.0 m-kg)

47. Install the bellhousing.

48. Install the air intake silencer.

49. Mount the engine heat exchanger.

The heat exchanger should be serviced when the engine is overhauled. Refer to *HEAT EXCHANGER* for service and inspection.

49. Mount the fuel filter assembly.

Attaching Nuts Torque 33 - 49 ft-lb (4.6 - 6.8 m-kg)

50. Install the alternator and drive belt.

CAUTION: Connect the alternator properly. Should the polarity be reversed, a powerful current would flow from the battery into the alternator, damaging the diodes and wiring harness.

- a. Install the alternator support bolt through the alternator leg (underside) into the engine casting.
- b. Swing the alternator into position on the adjusting bracket and fasten. Lightly tighten.
- c. Adjust belt tension.
- d. Tighten both bolts and recheck belt tension.

Support bolt Torque 27 - 38 ft-lbs (3.8 - 5.3 m-kg)

Adjusting bracket bolt Torque 9 - 10 ft-lbs (1.2 - 1.8 m-kg)

NOTE: Make certain the belts are perfectly aligned with the alternator and engine pulleys. If not, insert or remove spacers as needed, to align the alternator.

See *ALTERNATOR* for testing.

51. Install the raw water pump and drive belt. Insure it is in proper alignment with the crankshaft pulley. Check the belt tension.

Refer to *RAW WATER PUMP* for pump breakdown.

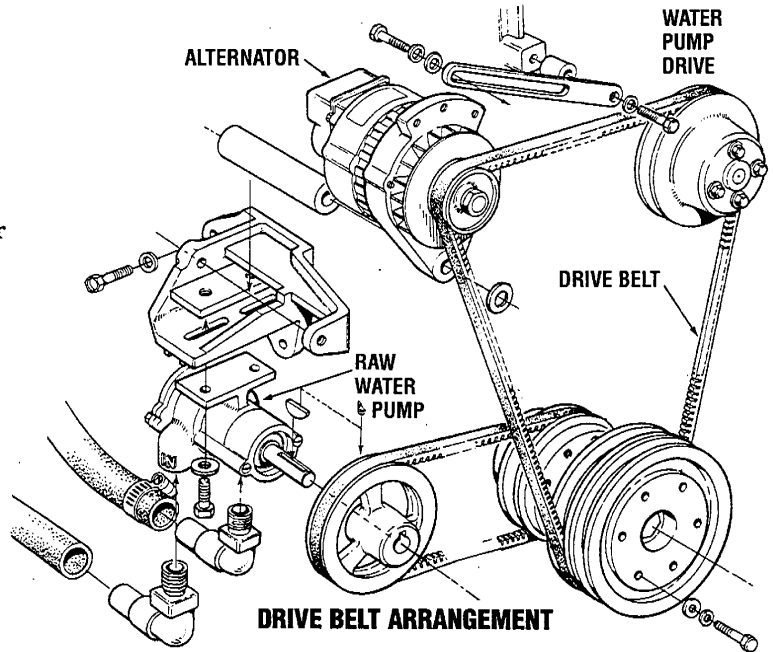

52. Install the oil and water sender and switch.

53. Install the starter motor.

54. Install the breaker panel and the preheat solenoid.

55. Reinstall the engine electrical harness.

56. Mount the complete exhaust manifold and the expansion tank to the cylinder head.

Manifold Mounting Bolts Torque 12 17 ft-lb (1.6 - 2.4 m-kg)

See *EXHAUST MANIFOLD* for service and inspection.

57. Assemble the wiring harness and ground wires.

58. Reconnect all DC wiring harness terminals to their engines components.

CAUTION: Check all AC and DC wiring connections to WESTERBEKE wiring schematics and diagrams.

ENGINE ASSEMBLY

MARINE ENGINE/TRANSMISSION

59. Assemble the damper plate to the flywheel.

Damper Plate Torque 14 - 20 ft-lb (1.7 - 2.7 m-kg)

60. Reinstall the marine transmission and fill with ATF Dextron III.

NOTE: Some transmissions, such as the Borg Warner Velvet Drive require oil coolers. Oil coolers should be cleaned, pressure tested and repainted at engine overhaul. The transmission oil cooler hoses should also be inspected. Refer to the text on Heat Exchangers.

61. Fill the engine cooling system with pre-mixed coolant (50/50 good quality antifreeze and distilled water).

Fill the engine oil sump to the mark on the dipstick with lube oil (A.P.I. spec. CF or CG-4).

The engine should be test run under load prior to re-installing. At this time readjust the valve clearances on the hot engine.

Allow the engine to cool to room temperature and retorque the cylinder head bolts and re-check the valve clearances.

See *ENGINE ADJUSTMENTS*.

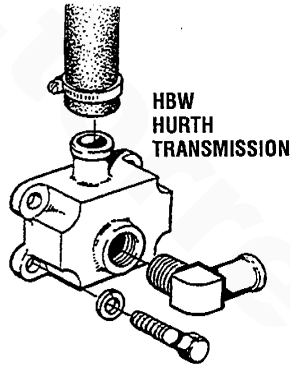
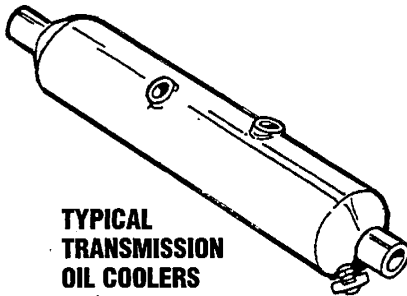

GENERATOR

59. Mount the generator back end assembly with its control panel. Reconnect all DC wiring and reconnect all AC connections.

CAUTION: Check all AC and DC wiring connections to WESTERBEKE wiring schematics and diagrams.

60. Fill the engine cooling system with pre-mixed coolant (50/50 good quality antifreeze and distilled water).

Fill the engine oil sump to the mark on the dipstick with lube oil (A.P.I. spec. CF or CG 4).

The engine should be test run under load prior to re-installing. At this time readjust the valve clearances on the hot engine.

Allow the engine to cool to room temperature and retorque the cylinder head bolts and re-check the valve clearances.

See *ENGINE ADJUSTMENTS*.

EXHAUST MANIFOLD / HEAT EXCHANGER

EXHAUST MANIFOLD

The exhaust manifold, which was disassembled from the cylinder head, should be inspected before reassembly.

1. Remove the exhaust nipples, elbows and plugs from the manifold.
2. Examine all parts for defects, corrosion and wear and replace as needed.
3. Flush out the manifolds interior with a liquid cleaner and rinse thoroughly with fresh water.
4. Use a pipe cleaner to clear the passage that connects from the filler neck to the coolant recovery tank tubing.
5. Flush out the coolant recovery tank and its connecting tube.

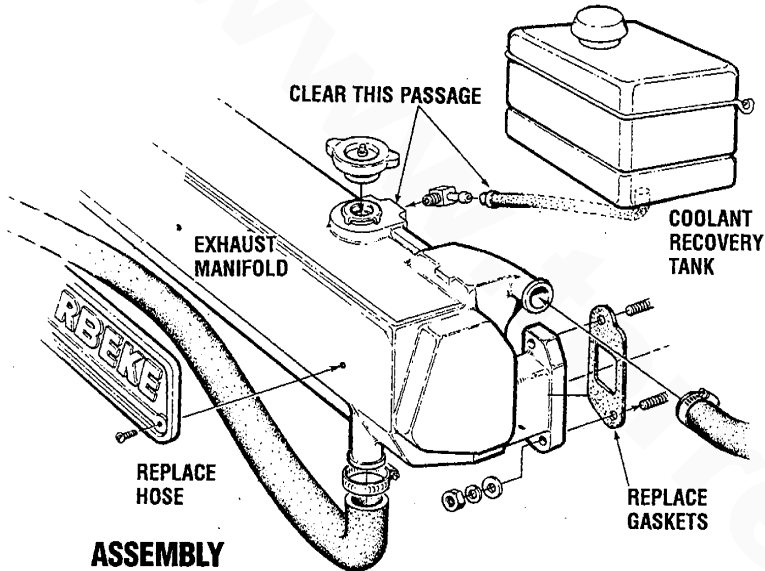

ASSEMBLY

1. If the manifold was removed as an assembly and left intact, it can be replaced on the cylinder head in the reverse order of removal. Do not reuse the gaskets; install new ones.
 - a. Loosely attach the manifold elbows to the cylinder head using new gaskets. Do not use any gasket sealant on these gaskets.
 - b. Gradually tighten each fitting to make sure of proper alignment of all the parts. This should be done in three steps.

Manifold Mounting Bolts Torque 12 - 17 ft-lb (1.6 - 2.4 m-kg)

2. Reinstall the exhaust connections. Use new gasket and check turbo clamp condition. Replace if suspect..

3. Check the manifold pressure cap. Open the valve by pulling it and make sure it closes when released. Make certain the upper and lower seals are in good condition. If any doubt, replace the cap.

CHECKING THE PRESSURE CAP

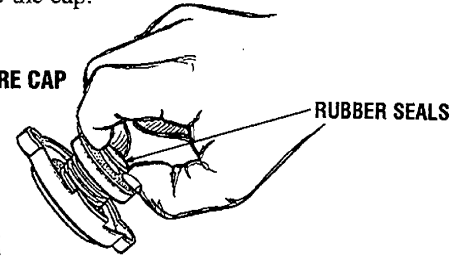

HEAT EXCHANGER

The heat exchanger should be inspected and serviced during an engine overhaul.

1. Disconnect the hoses and remove the hose fittings, petcock, drain plugs and zinc anode. Also, remove the end fittings and gaskets.
2. Inspect the tube (casing) for wear and dents, if at all suspect replace the heat exchanger.
3. Clean out any zinc debris and pressure test the coolant and raw water passages.
4. When reassembling, install new gaskets and O-rings. Apply some lubricant to the new gaskets and to the petcocks and fittings as you install them.
5. Install a new zinc anode.

NOTE: All of the above can be accomplished by sending the heat exchanger to a heat exchanger/radiator service shop. They will also service transmission and engine oil coolers.

6. Repaint the assembled heat exchanger with Westerbeke heat resistant spray enamel.
7. Reconnect all hoses, replacing them as needed.
8. Refill the system with coolant as detailed above.
9. Pressure test system and check for leaks.

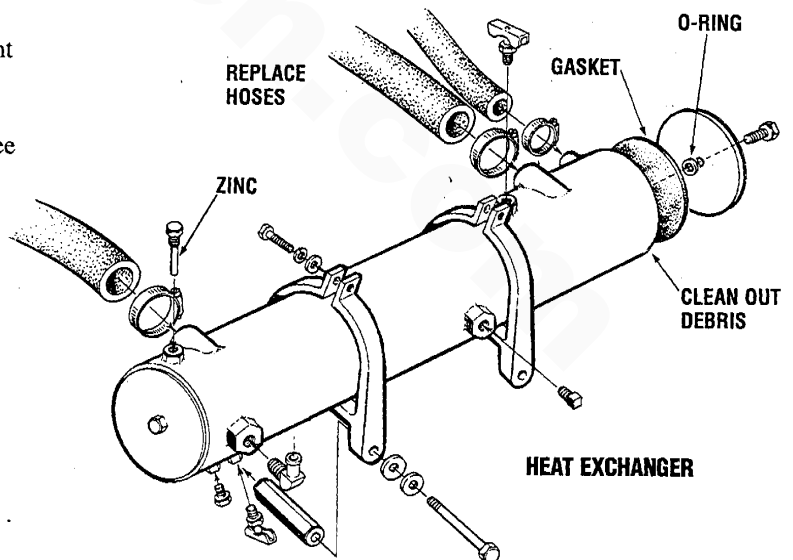

FUEL INJECTION PUMP

TESTING INJECTION TIMING

1. Remove the air intake/silencer assembly.
2. Remove the four high pressure injector lines that connect between the injection pump and injectors.
3. Remove the bolt and gasket installed on the distributor head of the injection pump.
4. Remove the valve rocker cover.
5. Rotate the crankshaft in normal direction of rotation using the front crankshaft pulley nut and place the No. 1 piston at TDC of its compression stroke. (No. 1 piston is first from the front of the engine).

NOTE: To verify, the rocker arms of No. 4 cylinder should be rocking, one opening, one closing.

6. Remove the snap ring from the end of the rocker shaft at cylinder No. 1 along with the retaining washer.
7. Loosen the rocker arm adjusting bolt so as to allow the arm to be removed from the push rod and slide it off the rocker shaft.
8. Press down on the valve and spring assembly and ensure the valve is hitting the top of the No. 1 piston. Then remove the cap, keepers and valve springs from the No. 1 valve.

NOTE: Ensure the valve moves freely in its guide. Take care to not drop the keepers down the push rod hole.

9. Position a dial indicator gauge on the valve stem and, using the front crankshaft pulley nut, rock the crankshaft counterclockwise and clockwise to locate the exact TDC of the compression stroke for the No. 1 piston. Then zero the indicator gauge to the valve stem (the gauge should be able to measure up to 0.3 inch of valve movement).

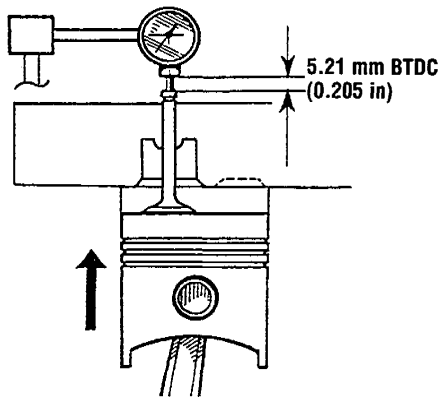

10. Slowly turn the crankshaft in the opposite direction of normal rotation until the indicator reads $0.180 \pm .005$ inches BTDC. It is advisable to go slightly more than 0.180 inches and then return to that figure to remove gear lash. The No. 1 piston is now at 30° BTDC. Verify the scribe mark on the injection pump outboard mounting flange is properly aligned with the scribe mark on the engine mounting case. At the six o'clock position on the outboard side of the injection pump is a semi-oval cover with two screws. Remove this cover and locate the sealing O-ring and timing washer 0.032 inches in thickness. Remove this washer and replace the cover.

11. Remove the plug and sealing washer from the aft center of the injection pump. The plug is centrally located where the four high pressure injector lines attach to the pump. In place of the plug install the Mazda tool #49 9140 074 measuring device. Ensure the measuring device rod contacts the plunger inside the pump and then zero the gauge.

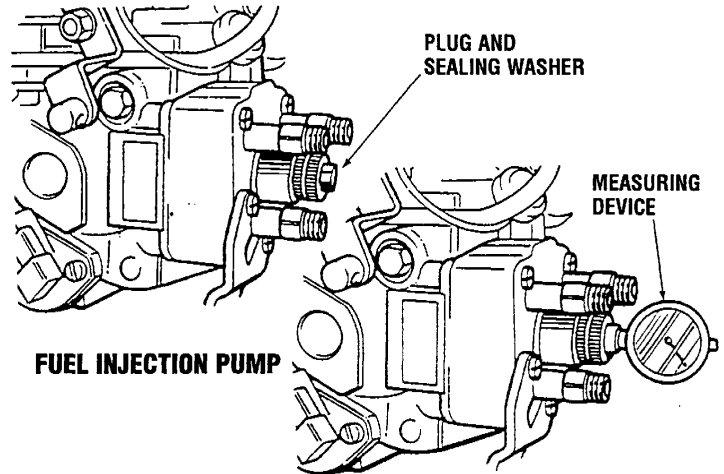

NOTE: When setting the dial gauge, confirm that the dial gauge pointer does not deviate from the scale mark of zero by slightly turning the engine crankshaft from left to right.

Turn the engine crankshaft in the normal direction of rotation to bring the No. 1 piston up to TDC. The dial indicator on the valve stem should show zero and the indicator on the injection pump should show 0.039 inches (1 mm) of movement.

ADJUSTING INJECTION TIMING

1. Loosen the nuts holding the injection pump to the engine. (The high pressure injector lines should not be attached to the injection pump.)
2. Make the adjustment by moving the injection pump itself. When the amount of movement of the measuring device indicator on the injection pump is too large, first turn the injection pump in the reverse direction of the engine rotation so that the dial gauge pointer indicates less than the scale mark of 0.039 inches (1 mm). These adjustments are to tighten the gear backlash.

Injection Pump Gear Lock Nut Torque 29 - 51 ft-lb (4.0 - 7.4 m-kp)

When the amount of the measuring device indicator on the injection pump is too small, turn the injection pump in the direction of normal engine rotation so that the measuring device indicator points to the scale mark of 0.039 inches (1 mm).

3. After the adjustment, tighten the injection pump hold-down nuts, and then confirm again that the adjustment has been done correctly.



FUEL INJECTION PUMP / FUEL LIFT PUMP

CHECKING CAM LIFT

1. Turn the crankshaft in the direction of normal engine rotation and read the maximum value which the dial indicator pointer on the measuring device shows. This value is cam lift.

Amount of Cam Lift 0.08 in (2.2 mm)

2. After this check, remove the measuring device and install the plug and sealing washer.
3. Reinstall the 0.032 inch thick timing washer in the injection pump.

BLEEDING THE INJECTION PUMP

1. The injector pump and injector high pressure lines will have to be bled of air after the lines have been reinstalled. To bleed the injection pump, first loosen the return connection (a). Then, by priming with the lever on the engine mounted fuel filter, supply fuel to the injection pump to remove the air from the injection pump. Continue until fuel clear of air passes out of the loosened return connection.
2. Next, bleed the high pressure lines by loosening them at their attachment to the fuel injectors. Loosen the attaching nuts (one to two turns) on all four fuel lines. Turn the key on and crank the engine with the starter until fuel spurts by the loosened connections. Stop cranking the engine. Tighten the attaching nuts and start the engine in the usual manner.

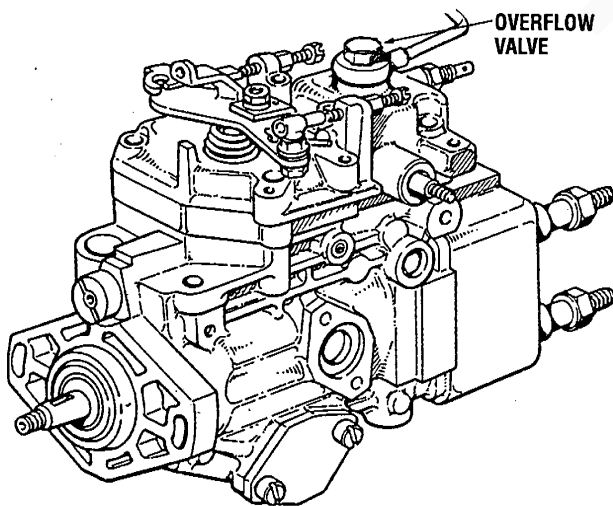

FUEL INJECTION PUMP

FUEL LIFT PUMP (EARLY MODELS)

The fuel lift pump should be cleaned and repainted. Install a new filter as illustrated and clean the ground wire terminal.

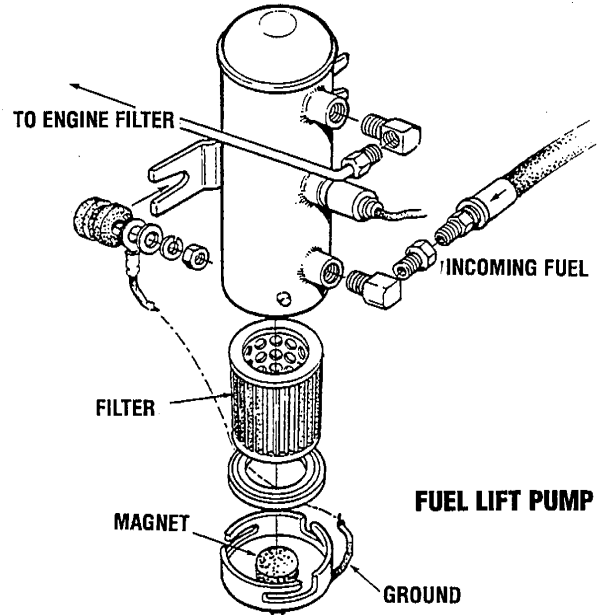

Troubleshooting

This pump operates during the start sequence when preheat is pressed. Simulate a start and depress preheat, the pump should produce a clicking sound indicating the pumping piston in the pump is working. If no clicking is heard, check that 12 volts are present at the pump connection and the pump is properly grounded.

1. Test the pump by connecting a battery and fuel line as illustrated. Fuel delivery must be 0.5 pints (225 cc) or more every fifteen seconds.

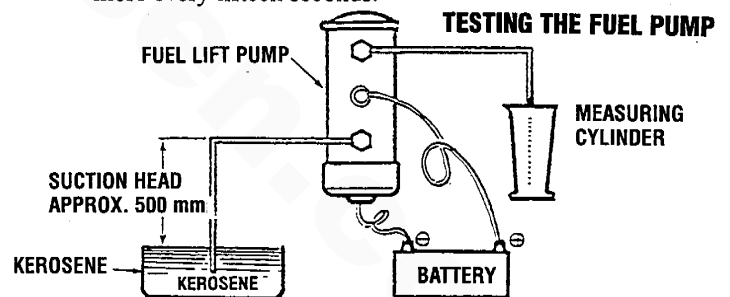

NOTE: Later model WESTERBEKE engines and generators use a solid state fuel lift pump that requires no maintenance. The above tests can be performed on these models.

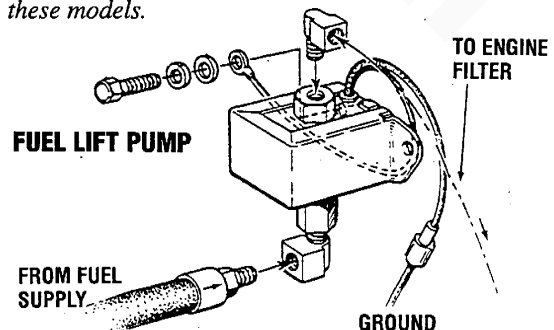

REMOVING THE INJECTORS

NOTE: Injector must be serviced in a "clean room" environment.

1. Disconnect the high pressure lines from the injectors and loosen the lines at their attachment to the injection pump and move them out of the way of the injectors. Avoid bending the lines.
2. Remove the fuel return line in its entirety from the top of the injectors. Take care not to lose the two sealing washers and banjo bolt that attaches the fuel return line to each injector.
3. Unscrew the injector from the cylinder head using a suitable 27 mm deep socket.

NOTE: Clean the area around the base of the injector prior to lifting it out of the cylinder head to help prevent any rust or debris from falling down into the injector hole. If the injector will not lift out easily and is held in by carbon build up or the like, work the injector side to side with the aid of the socket wrench to free it and then lift it out.

4. The injector seats in the cylinder head on a copper sealing washer. This washer should be removed with the injector and replaced with a new washer when the injector is reinstalled.

INJECTION TESTING/ADJUSTMENT

1. Using the nozzle tester, check the spray pattern and injection starting pressure of nozzle and, if it exceeds the limit, adjust or replace the nozzle. When using nozzle tester, take the following precautions:

CAUTION: The spray injected from the nozzle is of such velocity that it may penetrate deeply into the skin of fingers and hands, destroying tissue. If it enters the bloodstream, it may cause blood poisoning.

- a. If the diesel fuel of the nozzle tester is discolored, replace it. At the same time, clean or replace the filter.
- b. Set the nozzle tester in a clean place where there is no dust or dirt.

INJECTION PRESSURE TEST

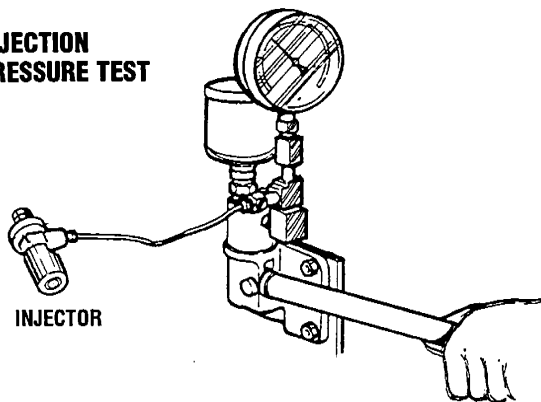

- c. Mount the nozzle and nozzle holder on the nozzle tester.
- d. Use the fuel at the approximate temperature of 68° F (20° C).
- e. Operate the hand lever of nozzle tester several times to bleed the air in the nozzle line, then move the hand lever at intervals of one stroke per second while reading the injection starting pressure.

Injector Starting Pressure 1,920 lb/in² (135 kg/cm²)

- f. If the fuel injection starting pressure is not within the specification, it can be adjusted by removing or adding shims in the injector body to achieve proper pressure.

NOTE: The shims are available in 27 kinds ranging from 0.5 mm to 1.54 mm at 0.02 increments. An increment of 0.4 mm causes the starting pressure to rise by approximately 68 lb/in² (4.8 kg/cm²).

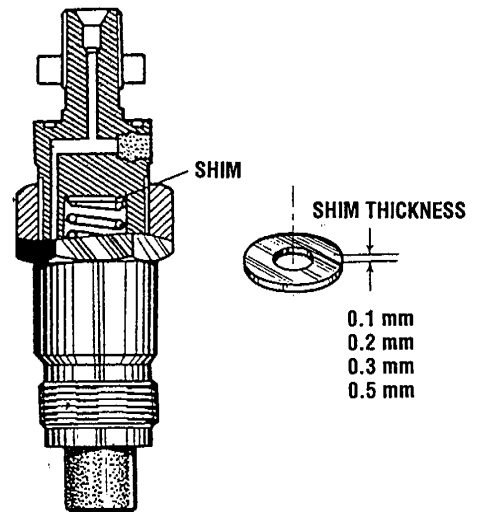

When replacing the shim, grip the retaining nut in a vise and remove the body with a wrench. Tighten the retaining nut to the specified torque.

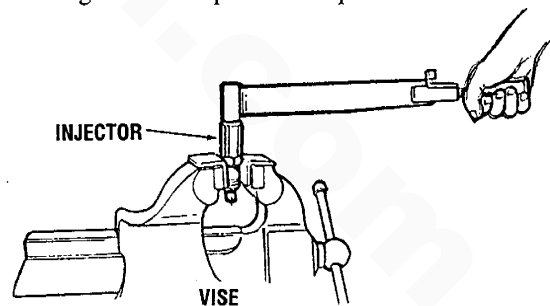

INSPECTING SPRAY PATTERN

1. Operate the hand lever of the nozzle tester at intervals of one stroke per second to check if the fuel is injected correctly in its axial direction. A nozzle is defective if it injects fuel in an oblique direction or in several separate strips. Also, a spray in the form of particles indicates a defect. These defects may sometimes be caused by clogging with dust and, therefore, all parts should be carefully cleaned before reassembly.

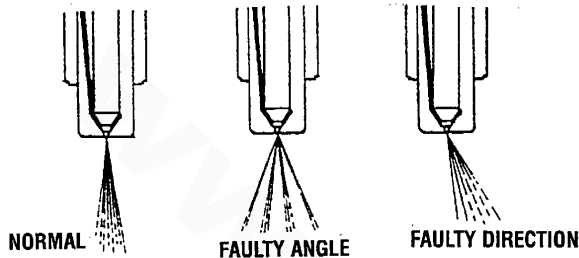

2. Operate the hand lever to raise the pressure up to 1635 psi (115 kg/cm²), which is 280 psi (20 kg/cm²) lower than the starting pressure. If, with pressure applied, fuel does not drip from the nozzle, oil tightness is satisfactory. Dripping of fuel with pressure applied, is indicative of damage to the needle valve or valve body or poor contact between both. In that event, both needle valve and valve body should be considered defective and replaced.

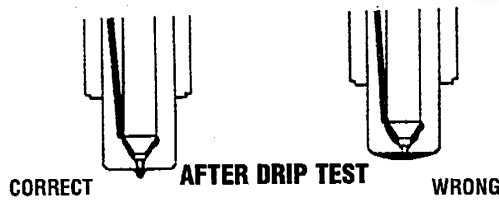

DISASSEMBLY AND INSPECTION

1. Clamp the nozzle holder in a vise, remove the nozzle nut and disassemble the nozzle body, spring, and needle.
2. Clean the disassembled parts with clean diesel fuel.

NOTE: Greatest possible care should be taken in handling the nozzles as they are precisely machined. The nozzle and the needle valve are matched parts. Do not mix their original combinations. Disassemble and wash each nozzle assembly separately.
 Carbon deposits on the nozzle body must be removed with a piece of hard wood. However, it would be advisable not to clean the surrounding area of the nozzle orifice to avoid possible damage to the orifice.
 Iron dust on the magnetic filter top must be removed completely.

5. Assure the needle valve, when it is pushed in the nozzle body, comes down into the valve seat by its weight about 0.7092in (18mm). If it does not, replace the assembly. If any defect is found, always replace the needle valve and the nozzle body as a unit.
6. Check that there is no flaw or other damage on mating surfaces and sliding surfaces of the nozzle body and the needle valve and, if present, replace the nozzle assembly.

ASSEMBLING THE INJECTOR

1. Assemble in the reverse order of disassembly.
NOTE: After assembling the injector, test it.
2. Tighten the nozzle body on the nozzle holder to the specified torque.

Nozzle Body Torque (24 mm socket) 8.0 - 10 lb/ft (58 - 72 kg/m)

INSTALLING

1. Install in the reverse order of removal.
NOTE: The copper washers should not be reused. Replace with new washers.
2. Tighten the nozzle on the cylinder head to the specified torque.

Nozzle Torque (27 mm socket) 43 - 51 lb/ft (6.0 - 7.0 kg/m)

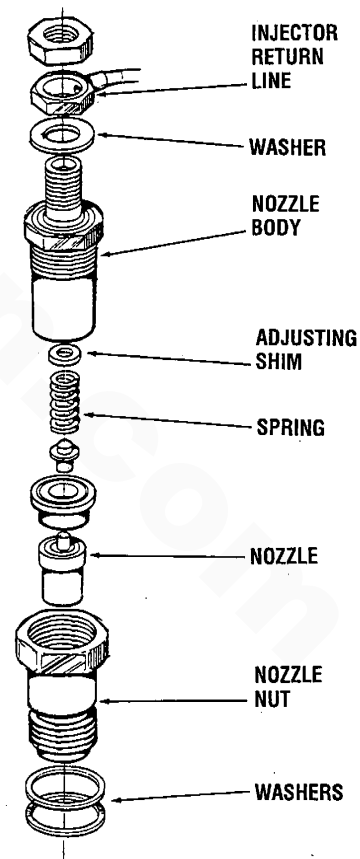

FUEL SYSTEM TROUBLESHOOTING

PROBLEM	PROBABLE CAUSE	VERIFICATION/REMEDY
Engine hard to start or fails to start.	<ol style="list-style-type: none"> 1. No fuel at injectors. <ol style="list-style-type: none"> a. No fuel in fuel tank and/or fuel shut off. b. Fuel filter clogged. c. Fuel filter clogged. d. Fuel shutoff solenoid not working. e. Injection pump faulty. 2. Fuel injectors faulty. 3. Water and/or air in fuel filters. 4. Injection timing incorrect. 5. Glow plugs not working. 	<ol style="list-style-type: none"> 1. Check causes a through e. <ol style="list-style-type: none"> a. Fill tank. Open shutoff and bleed system. b. Replace filter and bleed. c. Bleed pump. Check fittings for suction leak on fuel supply. d. Trouble shoot as described in previous section. e. Inspect pump. Repair or replace pump as needed. 2. Remove and test nozzles. Repair nozzles as needed 3. Remove water and/or bleed air from system. Check system for leaks and fuel tank for water contamination. 4. Check and adjust the timing. 5. Check glow plug circuit and repair as needed.
Engine idling too low.	<ol style="list-style-type: none"> 1. Idle speed too low. 2. Fuel filter clogged. 3. Incorrect injection pump timing. 4. High pressure injection line leaking. 5. Fuel injector leaking at sealing gasket in head. 6. Injection nozzle not operating properly. 7. Engine air intake obstructed. 	<ol style="list-style-type: none"> 1. Adjust idle stop as needed. 2. Replace filter and bleed fuel system. 3. Check timing and adjust as needed. 4. Slacken attaching nut and retighten. 5. Retighten injector and/or replace sealing washer. 6. Check nozzle and adjust as needed. 7. Check air flow intake silencer and air flow into engine compartment.
Fuel consumption too high.	<ol style="list-style-type: none"> 1. Idle speed too high. 2. Engine air intake restricted. 3. Injection timing incorrect. 4. Injector nozzle leaking. 5. Injector not operating properly. 6. Engine overloaded. 	<ol style="list-style-type: none"> 1. Check engine speed. 2. Check intake and correct. 3. Check timing and readjust pump as needed. 4. Tighten nozzle or replace sealing gasket. 5. Remove injector and adjust nozzle spray pressure. 6. Check propeller size and engine performance

(continued)

FUEL SYSTEM TROUBLESHOOTING

PROBLEM	PROBABLE CAUSE	VERIFICATION/REMEDY
Engine output and performance poor.	<ol style="list-style-type: none"> 1. Contaminated or inferior fuel. 2. Fuel filter obstructed. 3. Air in fuel system. 4. Injection pump timing incorrect. 5. Injector high pressure lines leaking. 6. Injectors not operating properly. 7. Shaft stuffing box too tight. 8. Valves improperly adjusted. 	<ol style="list-style-type: none"> 1. Purge fuel system and replace with quality fuel. 2. Remove and replace filter element. 3. Bleed and check for source. 4. Check the timing and adjust pump as needed. 5. Loosen and then retighten injector line attachment nut or replace the complete line. 6. Remove injectors and adjust spray pressure to proper setting. 7. Check shaft free movement and for heat. 8. Check valve adjustment and maintain.
Large amount of black exhaust smoke.	<ol style="list-style-type: none"> 1. Clogged fuel filter. 2. Restricted air intake. 3. Engine overloaded. 4. Injection timing. 5. Fuel injectors not operating properly. 	<ol style="list-style-type: none"> 1. Replace the fuel filter and bleed the system. 2. Remove air obstruction. 3. Check engine propeller size and engine performance no load through fully loaded. 4. Check the injection pump timing and adjust as needed. 5. Check nozzle spray pressure.setting.
Abnormal noise from engine	<ol style="list-style-type: none"> 1. Poor quality and/or incorrect fuel. 2. Incorrect injection timing. Timing too advanced. 3. Fuel injector stuck open. 	<ol style="list-style-type: none"> 1. Use No. 2 diesel fuel. 2. Check injection timing. 3. Locate and remove faulty injector. Replace or rebuild.

GLOW PLUGS

DESCRIPTION

The glow plugs are wired through the preheat solenoid. When PREHEAT is pressed at the control panel this solenoid should "click" on and the glow plug should begin to get hot.

INSPECTION

To inspect the plug, remove the electrical terminal connections, then unscrew or unclamp each plug from the cylinder head. Thoroughly clean each plug's tip and threads with a soft brush and cleaning solution to remove all the carbon and oil deposits. While cleaning, examine the tip for wear and burn erosion; if it has eroded too much, replace the plug.

TESTING

An accurate way to test glow plugs is with an ohmmeter. Touch one prod to the glow plug's wire connection, and the other to the body of the glow plug, as shown. A good glow plug will have a 1.0 - 1.5 ohm resistance. This method can be used with the plug in or out of the engine. You can also use an ammeter to test the power drain (8 - 9 amps per plug).

⚠ WARNING: *These glow plugs will become very hot to the touch. Be careful not to burn your fingers when testing the plugs.*

Re-install the plugs in the engine and test them again. The plugs should get very hot (at the terminal end) within 20 to 25 seconds. If the plugs don't heat up quickly, check for a short circuit. When reinstalling the glow plugs, use anti-seize compound on the threads.

⚠ WARNING: *Do not keep a glow plug on for more than 30 seconds.*

Glow Plug Tightening Torque 7 - 11 ft-lb (1.0 - 1.5 m-kg)

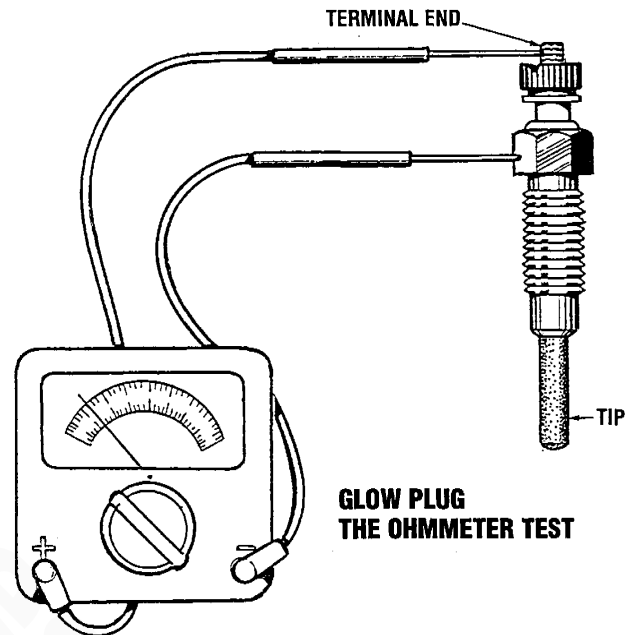

VALVE CLEARANCE ADJUSTMENT

1. Warm the engine to normal operating temperature.
2. Pull off the air breather pipe from the rocker cover. Remove the rocker cover bolts and remove the rocker cover to expose the rocker shaft and valve assembly.
3. Remove the glow plugs from each of the cylinders to enable the crankshaft to be easily rotated by hand to position each cylinder for valve adjustment. Valves are adjusted with the piston in the cylinder being adjusted at TDC of its compression stroke.

NOTE: Retorque the cylinder head bolts before adjusting the engine's valves.

4. Loosen the head bolts in the reverse order of tightening.

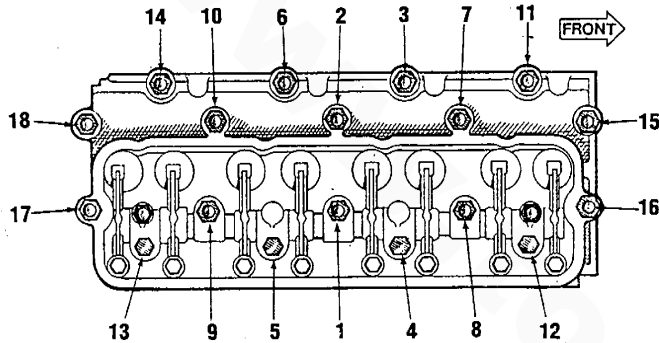

5. Tighten the head bolts in the order shown.
Cylinder Head Bolt Torque 85 90 ft-lb (11.8 - 12.5 m-kg)

6. Set the piston of No. 1 cylinder to TDC (compression) and check the valve clearance at each position indicated. If the clearance is incorrect, adjust to specifications:
 Intake - No. 1 and No. 2 cylinders; and
 Exhaust - No. 1 and No. 3 cylinders.
7. Turn the crankshaft once, setting the piston of No. 4 cylinder at TDC (compression) and adjust to the following specifications:
 Intake - No. 3 and No. 4 cylinders; and
 Exhaust - No. 2 and No. 4 cylinders.

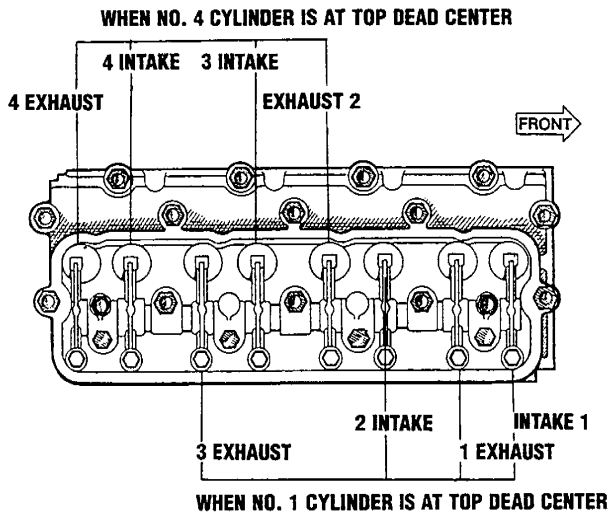

8. Adjust each valve's clearance by inserting a 0.012in (0.03mm) feeler gauge between the rocker arm and the valve stem. Make sure to adjust all valves when the engine is cold.

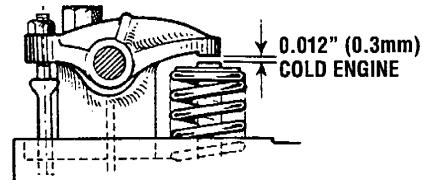
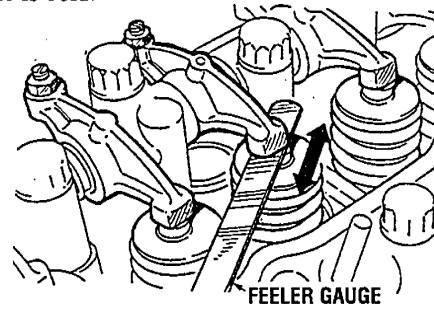

9. Install the cylinder head cover.
Head Cover Bolt Torque 2 - 3 ft-lb (0.3 - 0.45 m-kg)

ENGINE COMPRESSION

Check the compression pressure. To do this, warm the engine, remove all fuel injectors, or glow plugs, disconnect the fuel shut-off solenoid wire, and install a compression adapter in the injector hole or glow plug hole. Connect a compression tester on the adapter and crank the engine with the starter motor until the pressure reaches a maximum value. Repeat this process for each cylinder. Look for cylinders with dramatically (at least 20%) lower compression than the average of the others. Compression pressure should not differ by more than 42.7 psi (3.0 kg/cm²) at 200 rpm.

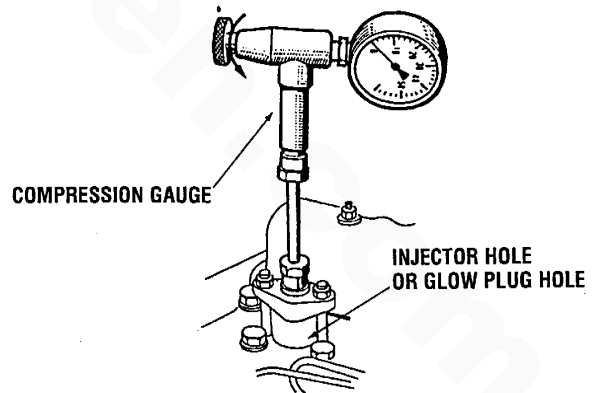

Compression pressure standard	427 psi at 200 rpm (30.0 kg/cm ²)
Compression pressure limit	384 psi at 200 rpm (27.0 kg/cm ²)

If a weak cylinder is flanked by healthy cylinder, the problem is either valve or piston related. Check the valve clearances for the weak cylinder, adjust as needed and test again. If the cylinder is still low, apply a small amount of oil into the cylinder to seal the rings and repeat the test. If compression comes up - the rings are faulty.



Abnormally high readings on all cylinders indicates heavy carbon accumulations, a condition that might be accompanied by high pressures and noise.

NOTE: In case of severe vibrations and detonation noise, have the injectors checked and overhauled by an authorized fuel injection service center. Poor fuel quality, contaminates and loss of positive fuel pressure to the injection pump will result in injector faults.

When re-installing the glow plugs use anti-seize compound.

SETTING THE IDLE SPEED (PROPULSION ENGINE)

1. Warm the engine to normal operating temperature.
2. Stick a piece of suitable reflecting tape on the crankshaft pulley.
3. Idle the engine.
4. Use the light of a photoelectric strobe type tachometer on the reflecting tape and compare with the readings on the electric tachometer.

Normal idle speed 650 - 950 rpm

NOTE: The idle speed may vary according to the transmission and propeller.

5. To adjust the engine idle speed, loosen the lock nut of the idle adjustment bolt and turn the bolt clockwise to increase idle speed and counterclockwise to reduce.

NOTE: Should the engine rpm be in question, verify the tachometer readings as shown at the instrument panel. See TACHOMETER.

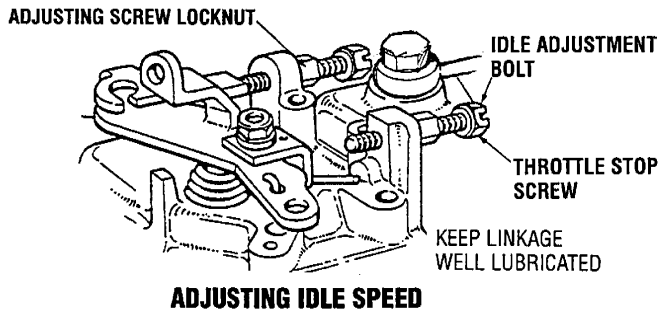

SPEED ADJUSTMENT (GENERATOR)

NOTE: Speed adjustment of the generator (hertz) is controlled by the electronic governor see ELECTRONIC GOVERNOR for speed and gain adjustments.

Early Models Without Electronic Governing

Engine speed is maintained by the governor mechanism inside the fuel injection pump (61.5 - 62.0 hertz at no-load and 58.5 - 59.0 hertz at full rated generator output). Engine no-load speed is adjusted by positioning the throttle lever against the adjustable throttle stop screw, lock wiring it at that position, and tensioning the throttle stop screw against the throttle lever and securing it with its lock nut.

When servicing the injection pump, the service shop must be advised if the pump is to be used in a generator application. The service shop will have to remove and replace the governor spring with a propulsion spring. Once the pump is set to propulsion specifications, the generator spring is reinstalled in the injection pump and the pump remounted on the engine. The throttle is then set for the proper engine no-load speed (hertz).

For disassembly, inspection, reassembly and internal adjustments of the injection pump, it is recommended the pump be taken to a qualified injection service shop authorized to service Diesel KiKi injection equipment.

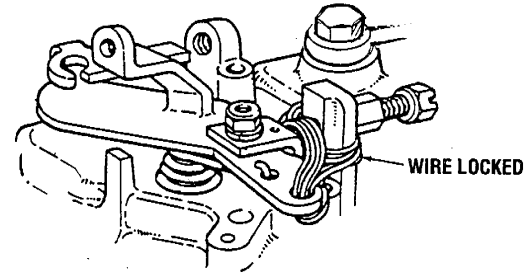

ENGINE STOP SOLENOID - PROPULSION/GENERATOR

This solenoid is installed on the top rear of the injection pump and is activated by 12 VDC electrical current.

NOTE: To service generator applications, refer to the GENERATOR section of this manual.

Troubleshooting

1. The solenoid does not operate when the keyswitch is turned "ON". (Preheat depressed)
 - a. Are the engine batteries turned "ON"?
 - b. Is the 20 amp circuit breaker set?
 - c. Is 12 VDC present at the solenoid connection?
2. The solenoid does not stop the engine when the keyswitch is switched "OFF". (Stop switch depressed)
 - a. Check to see if 12 VDC is still present at the solenoid electrical lead with the key off. (Stop switch depressed)
 - b. Remove solenoid from injection pump and ensure plunger and spring in the solenoid are not sticking.

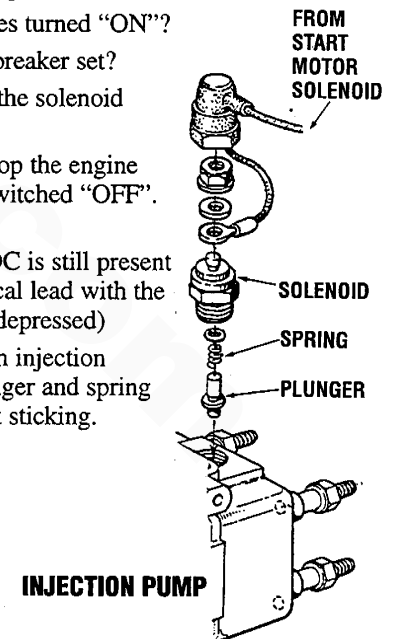

REMOVING THE PUMP

Remove in the following order: coolant (drain as needed); V-belt; water hoses; water pump attaching nuts; and water pump.

DISASSEMBLY

1. Remove the pump pulley boss by using a support and press.
2. Remove the bearing shaft from the impeller and bearing housing by using a support block and press.
3. Remove the snap ring with snap ring pliers and press out the water pump shaft from the bearings.

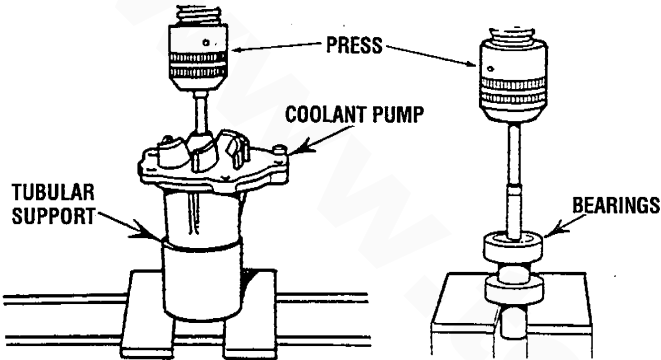

INSPECTION

Inspect the shaft, bearings and impeller. Look for cracks and damage. Check the housing gasket and inspect the rear seals and small end gaskets. Replace any parts that show wear.

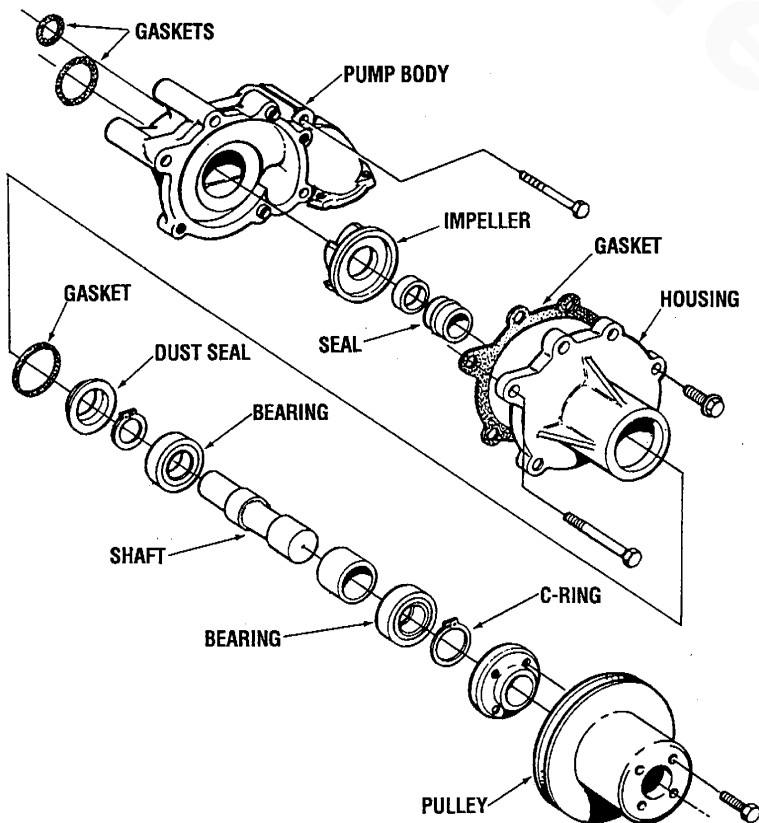

ASSEMBLY

Assemble the water pump in the reverse order of disassembly, using the following procedure:

1. Fill lithium grease (lithium base NLGI No. 2) into the following positions.
 - Ball bearings
 - Approximately 1/3 space between both ball bearings
 - Space between the ball bearing and water baffle plate.
2. Apply a thin coat of engine oil to the press fit surface of the water seal and press the larger end into the proper aperture of the pump using a tubular mandrel. (Mazda tool # 49 0636 145).

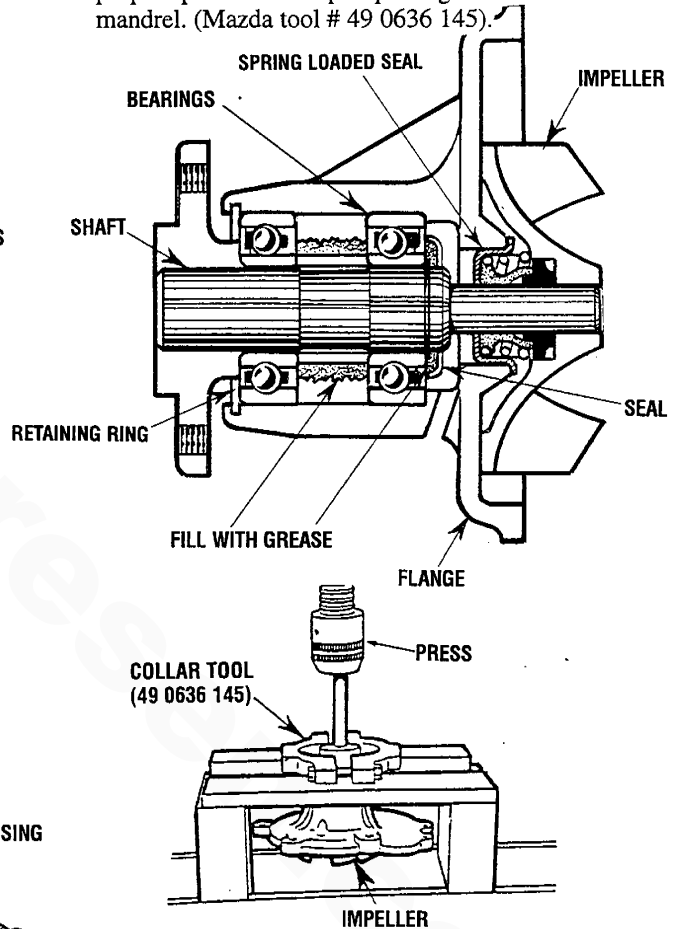

NOTE: Do not allow oil or grease to contaminate the surfaces of the ceramic ring or the graphite (small end) of the spring-loaded seal.

3. After the water pump has been assembled, check if the pump shaft rotates smoothly.

INSTALLING THE PUMP

1. Install in the reverse order of removal.

NOTE: Use a new gasket.
2. After installing the pump, fill the system with coolant and operate the engine to check for leaks.



REMOVING THE OIL PUMP

Remove from the engine in the following order:

1. Oil Pan;
2. Oil Pump Set Screw;
3. Oil Pipe Attaching Bolts; and
4. Oil Pump

DISASSEMBLY

Disassemble in the following order: Oil Pipe and Gasket; Oil Strainer and Gasket; Oil Pump Cover; Drive Gear (use a press and suitable mandrel); Inner Rotor and Shaft Assembly; Outer Rotor; Relief Valve Assembly; and Oil Pump Body.

INSPECTION

1. **Visually check the disassembled parts and replace faulty parts.** Check the sliding surface of pump cover with special care and replace the cover if the surface has steps or excessive streaks. (Minor steps streaks may be repaired by rubbing them with a compound on a surface plate.)

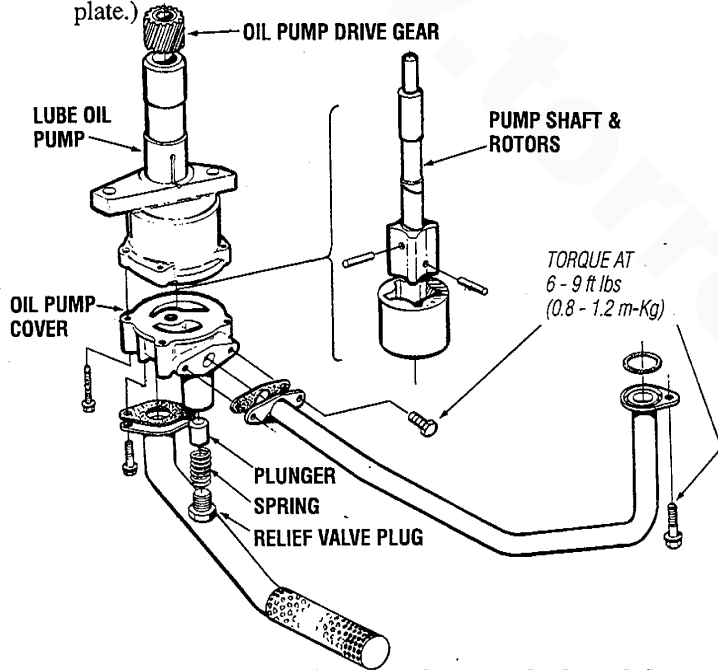

2. **Inspect the clearance between the pump body and the shaft.** Measure the clearance with a dial gauge and magnet base. When the clearance exceeds the limit, replace the pump drive shaft inner rotor, pump body and drive gear.

Clearance Limit 0.0024 in - 0.0079 in (0.06 - 0.15 mm)

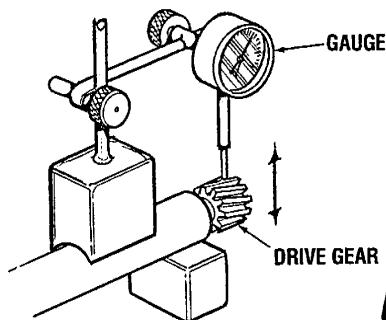

3. **Inspect the clearance between the inner rotor and the outer rotor.** Check the clearance between the lobes of the rotors with a feeler gauge. If the clearance exceeds the limit, replace both rotors.

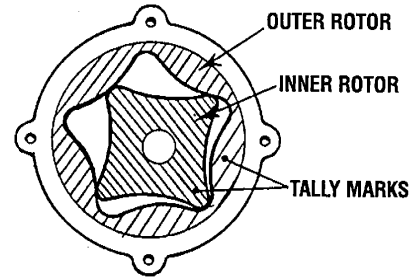

Clearance Limit 0.055 - 0.0100 in (0.14 - 0.25 mm)

4. **Inspect the clearance between the outer rotor and the pump body.** Check the clearance between the outer rotor and pump body with a feeler gauge. If the clearance exceeds the limit, replace the rotor or pump body.

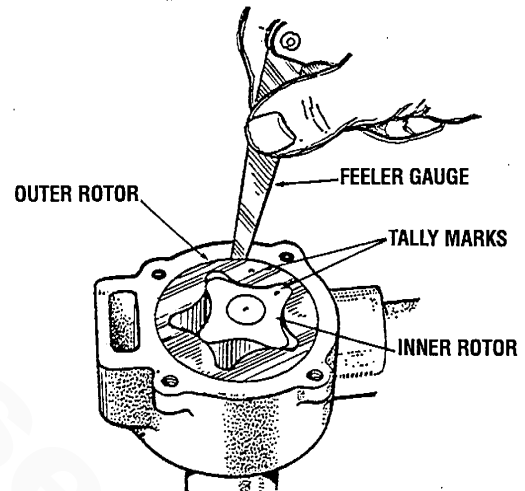

Clearance Limit 0.055 - 0.0100 in (0.14 - 0.25 mm)

5. **Check the clearance between the rotor and the pump cover.** Inspect the end float of the rotors. Place a straight-edge across the pump body and measure the clearance between the rotor and straight edge with a feeler gauge. If the clearance exceeds the limit, replace the drive gear, drive shaft, inner rotor, outer rotor and pump body.

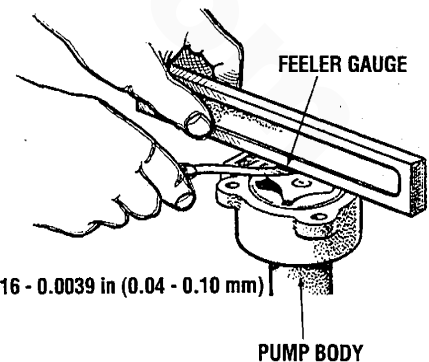

Clearance Limit 0.0016 - 0.0039 in (0.04 - 0.10 mm)



LUBRICATING OIL PUMP

6. Measure the free length of the plunger spring. Check the relief valve for worn plunger and fatigued spring.

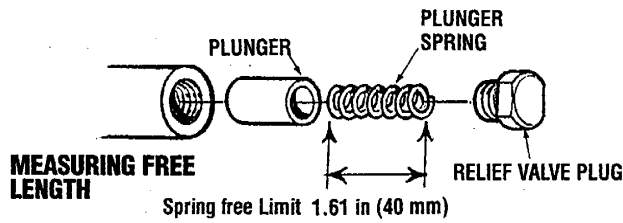

RELIEF VALVE ASSEMBLY

ASSEMBLY

7. Assemble in the reverse order of disassembly.

NOTE: When installing the rotors into the body, be sure that the tally marks on the rotors are positioned toward the cover.

Cover Tightening Torque (7/16" socket) 5.8 - 8.7 ft-lb (0.8 - 1.2 m-kg)

INSTALLING THE OIL PUMP

1. Install in reverse order of removal.

NOTE: When installing the set screw, apply sealing compound on the set screw threads.

OIL PRESSURE

TESTING OIL PRESSURE

The lubricating system is a pressure feeding system using an oil pump. The engine oil is drawn from the oil sump by the oil pump, which drives the oil, under pressure, through the oil filter, oil cooler and various lubricating points in the engine. The oil then returns to the oil sump to repeat the continuous cycle. When the oil pressure exceeds the specified pressure, the oil pushes open the relief valve in the oil pump and returns to the oil sump, keeping the oil pressure within its specified range.

To test the oil pressure, remove the oil pressure sender, then install a mechanical oil pressure gauge in its place. After warming up the engine, set the engine speed at 3600 rpm and read the oil pressure gauge.

Oil Pressure 35.0 lb/in² (3.8 kg/cm²) or more at 1800 rpm
54.04 lb/in² (3.8 kg/cm²) or more at 3600 rpm

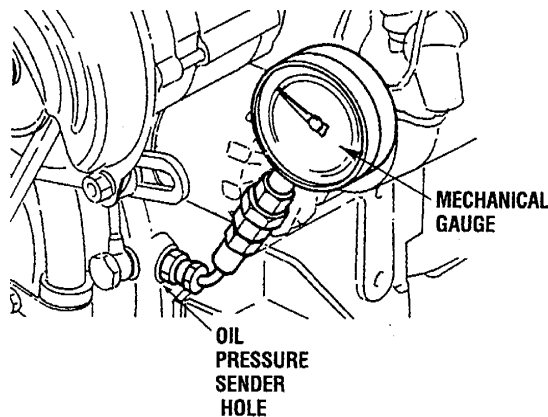

LOW OIL PRESSURE

The specified safe minimum oil pressure is 4.3 + 1.4 psi (0.3 + 0.1 kg/cm²). A gradual loss of oil pressure usually indicates a worn bearings. For additional information on low oil pressure readings, see the *ENGINE TROUBLESHOOTING* chart.

OIL PRESSURE SWITCH/SENDER

When performing an engine overhaul, replace the oil pressure switch and the oil pressure sender.

When installing the new parts apply a teflon sealant to the threaded ends being careful not to close off the oil hole in the sender.

Oil Pressure Sender and Switch Torque 9 - 13 ft-lb (1.2 - 1.8 m-kg)

CAUTION: Oil Pressure Switch - Do not use lock pliers, vise grips or pipe wrenches on the oil pressure switch. Use the correct socket which is available from Snap-On, Proto, New Britain and others. Damage to the switch will cause oil leaks and/or switch failure.

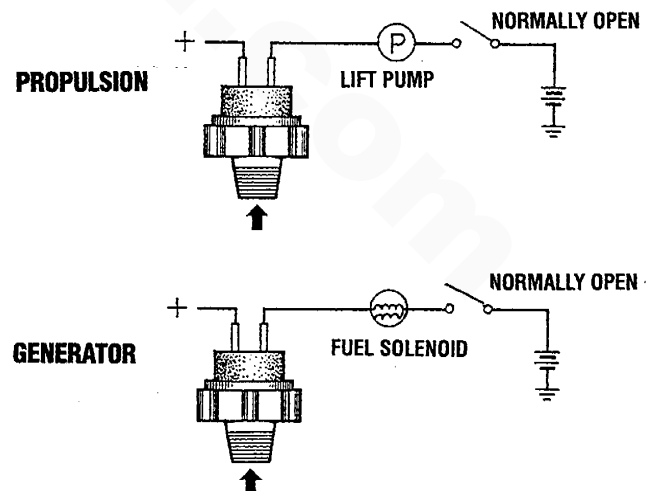

RAW WATER PUMP

PUMP OVERHAUL

NOTE: Since completely rebuilding a damaged or worn pump from individually purchased parts would almost match the price of a new pump, WESTERBEKE recommends that a new pump be purchased.

Before disassembling the raw water pump, inspect the pump by rotating the drive shaft. If it is rough, frozen, or seems to have excessive play, replace the entire pump.

Disassembly

The pump, as removed from the engine, will have hose attachment nipples threaded into its inlet and outlet port. They may be left in place or removed if they interfere with the pump disassembly. Note the port location and positioning if removed.

1. Loosen the set screw with an allen wrench and remove the water pump pulley from the shaft. Taking care not to lose the key.
2. Remove the four cover screws, the cover and the cover gasket.

NOTE: Replacement of the cover gasket is recommended; however, if you are going to reuse it, keep the gasket well lubricated until the pump is reassembled. If it's allowed to dry, the gasket will shrink and not be reusable.

3. Pull out the impeller with long nose pliers or a pair of screwdrivers.
4. Remove the cam screw and cam.

5. Remove the housing assembly, releasing the shaft, bearing and seal assembly. This will allow the bearing and seal to be disassembled for inspection.

NOTE: It may be necessary to use a drift and arbor press to press the bearing and seal assembly from the shaft.

6. Inspect all parts and replace those showing wear or erosion.
7. Use the illustration to assist in reassembling the raw water pump.
 - a. Apply a small amount of petroleum jelly to the seal's inner race and to the impeller shaft at reassembly.
 - b. When positioning the cam in the housing use a small amount of Permatex #1 on the inner cam surface and cam screw head; remove any excess from the impeller housing.
 - c. Apply a light film of silicon or petroleum jelly to the inner surface of the housing for the impeller
8. When the pump is assembled, reposition and tighten the hose nipples into the pump housing, use Teflon sealant on the nipple thread. Assemble the pump to the engine and attach the hoses and the belt.

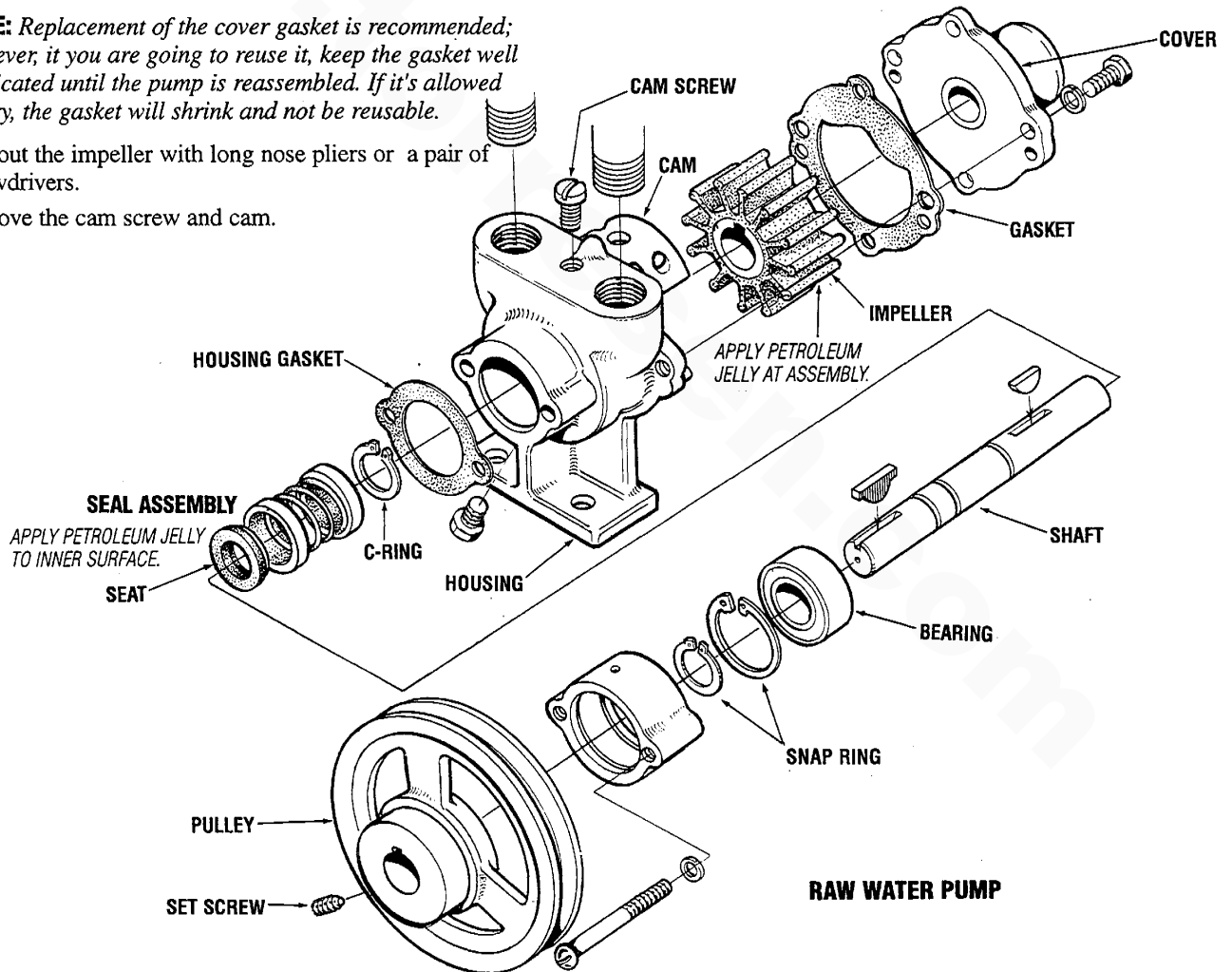

DESCRIPTION

The starter can be roughly divided into the following sections:

- A motor section which generates a drive power.
- An overrunning clutch section which transmits an armature torque, preventing motor overrun after starting.
- A switch section (solenoid) which is operated when actuating the overrunning clutch through a lever and which supplies load current to the motor.

The starter is a new type, small, light-weight and is called a high-speed internal-reduction starter. The pinion shaft is separate from the motor shaft; the pinion slides only on the pinion shaft. A reduction gear is installed between the motor shaft and a pinion shaft. The pinion sliding part is not exposed outside the starter so that the pinion may slide smoothly without becoming fouled with dust and grease. The motor shaft is supported at both ends on ball bearings. The lever mechanism, switch and overrunning clutch inner circuit are identical to conventional ones.

ADJUSTMENT AND REPAIR

If any abnormality is found by the following tests, the starter should be disassembled and repaired.

Pinion Gap Inspection

1. Connect a battery (12V) between the starter terminal S and the starter body, and the pinion drive should rotate out and stop.

CAUTION: Never apply battery voltage for over 10 seconds continuously.

2. Lightly push the pinion back and measure the return stroke (called pinion gap).
3. If the pinion gap is not within the standard range, 0.0197 - 0.0788in (0.5 to 2.0mm), adjust it by increasing or decreasing the number of shims on the solenoid. The gap is decreased as the number of shims increases.

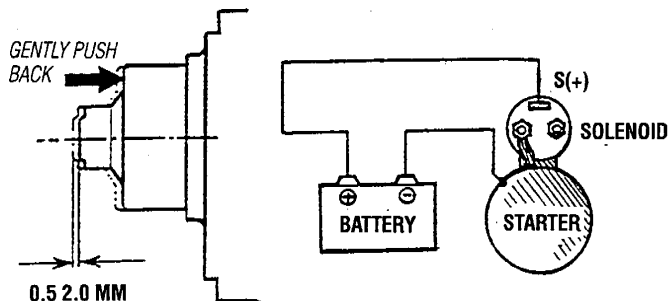

PINION GAP

No-Load Test

1. Connect the ammeter, voltmeter, and battery to the starter as illustrated.
2. When the switch is closed, the pinion must protrude and the starter must run smoothly (at 3000 rpm or more). If the current or starter speed is out of specification, disassemble the starter and repair it.

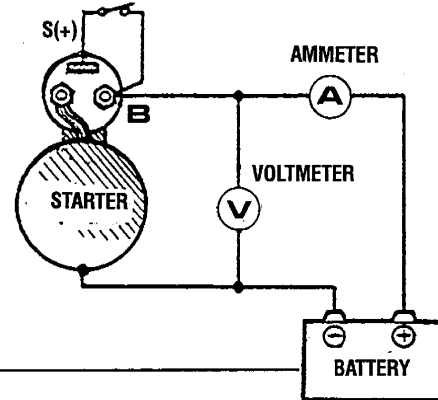

CAUTION: Use thick wires as much as possible and tighten every terminal securely. This is a solenoid shift-type starter which makes a rotating sound louder than that of a direct-drive type starter. When detecting starter rotation at the pinion tip, be careful not to come in contact with the pinion gear when it protrudes.

SOLENOID

Perform the following tests. If any test result is not satisfactory, replace the solenoid assembly.

1. Inspect the solenoid for continuity between terminals (+) and (-) and between terminals S and the body and M and the body. There should be no continuity found between terminals S and M. Continuity will be found between terminals S and the body and terminal M and the body.

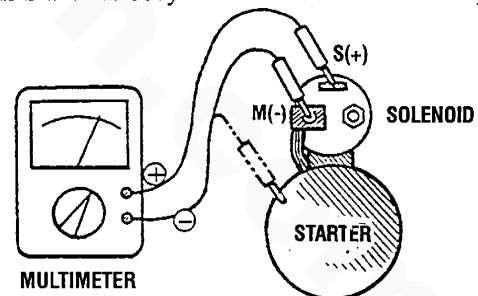

NOTE: Disconnect the wire from terminal M.

2. Connect a battery to the solenoid's terminal S for (+) and M for (-). Have a switch in the + lead and close it. The pinion drive should extend fully out.

CAUTION: Do not apply battery current for more than 10 seconds when testing the solenoid.

3. **Holding test.** With a battery connected to the solenoid terminal S (+) and to the starter body, manually pull out the pinion fully. The pinion must remain at that position even when released from holding with your hand.

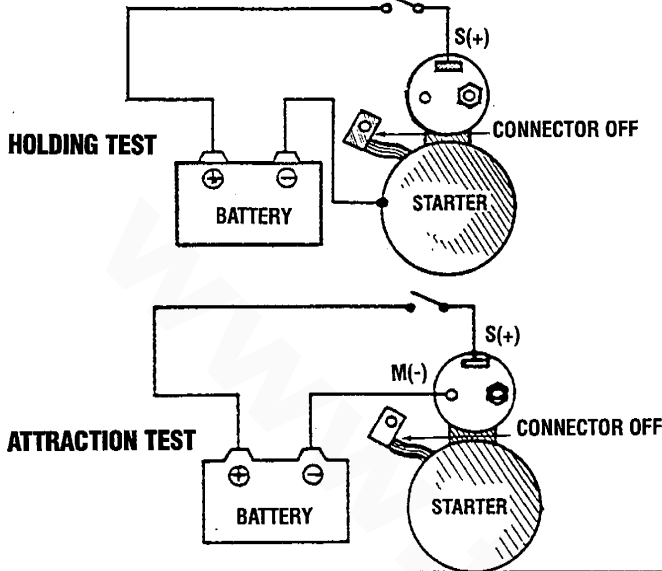

4. **Return test:** With a battery connected to the solenoid terminal M (-) and to the starter body, manually pull out the pinion fully. The pinion must return to its original position when released from holding by hand.

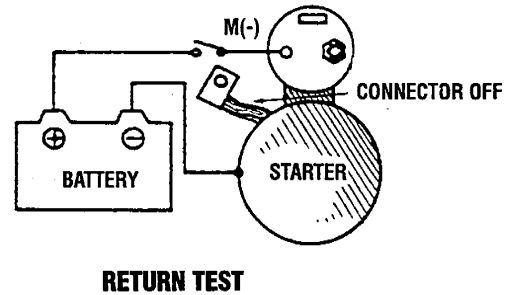

STARTER DISASSEMBLY

1. Disconnect the wire from the solenoid terminal M (-).
2. Loosen the two screws fastening the solenoid. Remove the solenoid assembly.
3. Remove the two long through bolts and two screws fastening the brush holder. Remove the rear bracket.
4. With the brushes pulled away from the armature, remove the yoke and brush holder assembly. Then pull the armature out.
5. Remove the cover, pry the snap ring out, and remove the washer.
6. Unscrew the bolts and remove the center bracket. At the same time, the washers for the pinion shaft end play adjustment will come off.
7. Pull out the reduction gear lever and lever spring from the front bracket.
8. On the pinion side, pry the snap ring out, and pull out the pinion and pinion shaft.
9. At each end of the armature, remove the ball bearing with a bearing puller. It is impossible to replace the ball bearing press-fitted in the front bracket. If that bearing has worn off, replace the front bracket assembly.

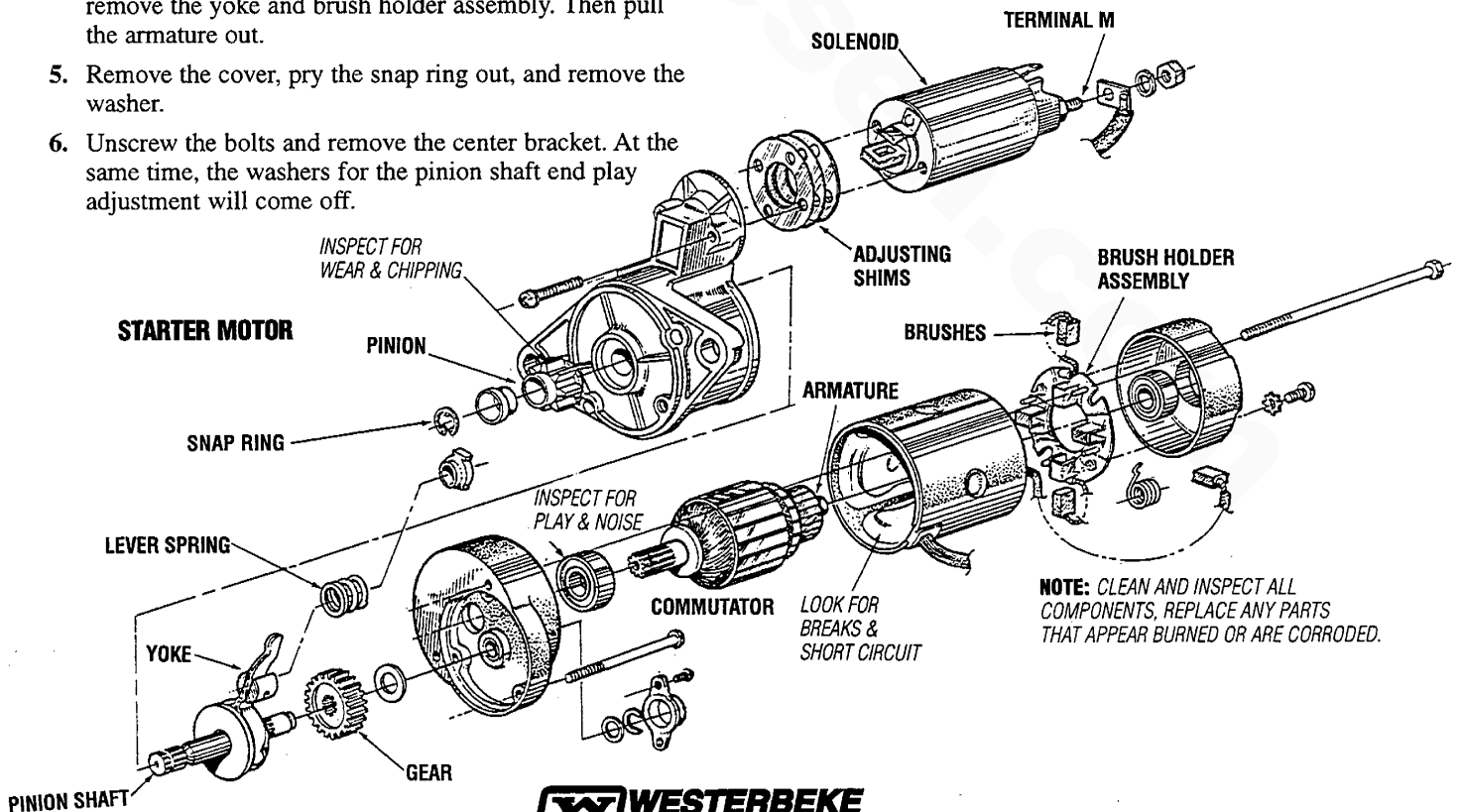

STARTER MOTOR

STARTER INSPECTION

Solenoid

Inspect the solenoid for continuity between terminals S and M and between terminals S and body. No continuity should be found between S and M. Continuity should be found between S and the body and M and the body.

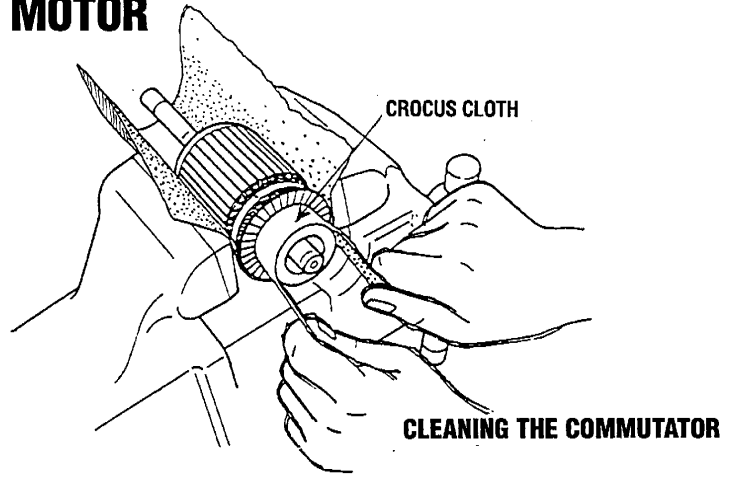
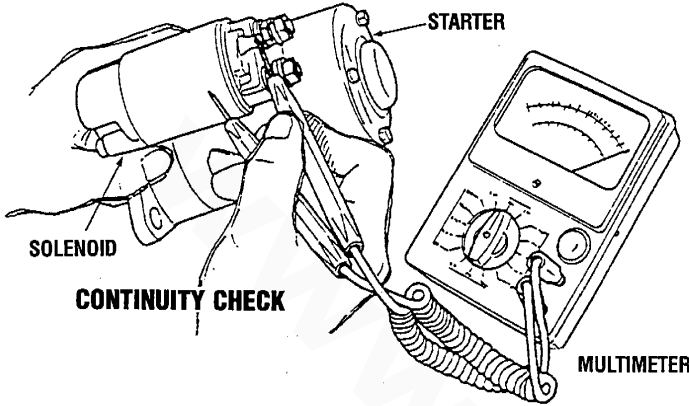

Inspecting The Armature

1. Check the armature with a growler tester. If it's short circuited, replace the armature. Also check for insulation between the commutator and its shaft. If poorly insulated, replace the armature.

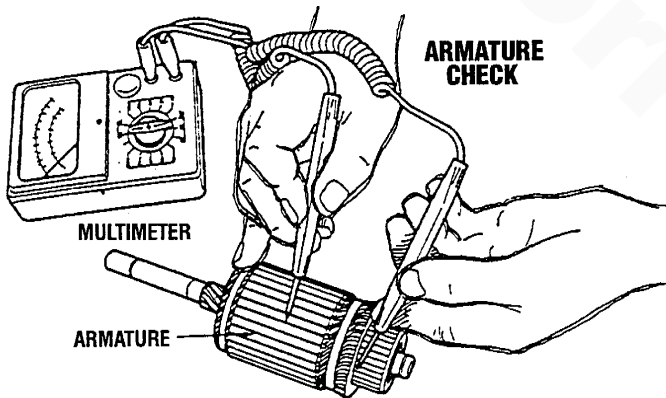

Brush and Brush Holder Inspection

1. Check the brushes. If worn out beyond the service limit, replace the brushes.

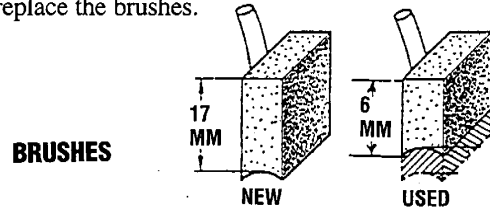

Brush Height Standard	0.669 in (17 mm)
Brush Height Limit	0.2363 in (6 mm)

2. Check the brush spring tension. A weak or defective spring will cause excessive brush wear; replace the springs if suspect.

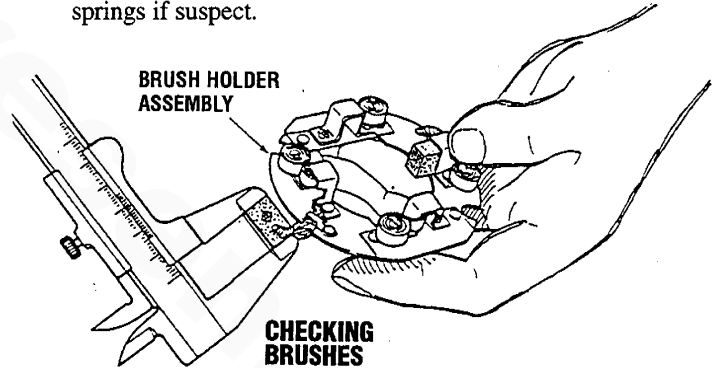

2. Measure the commutator O.D. and the depth of undercut. Repair or replace it if the service limit is exceeded. Also check the commutator outside surface for dirtiness and roughness. If rough, polish the commutator with fine crocus cloth.

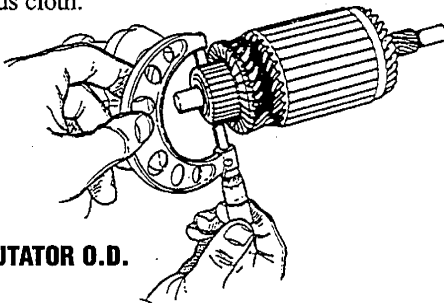

Commutator Outside Diameter Standard	1.523 in (38.7 mm)
Commutator Outside Diameter Limit	-0.039 in (-1.0 mm)

3. Check for insulation between the positive brush holder and holder base. If poorly insulated, replace the holder assembly. Also check the brush holders for proper staking.

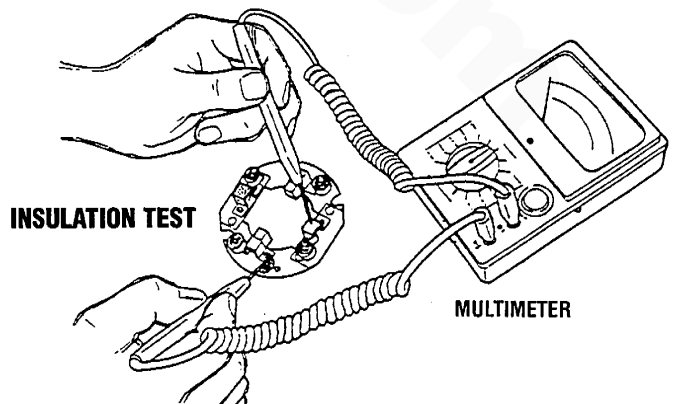

Field Coil Inspection

1. Check for insulation between one end (brush) of the coil and yoke.
2. Check for continuity between both ends (brushes) of the coil
3. Check the poles and coil for tightness.

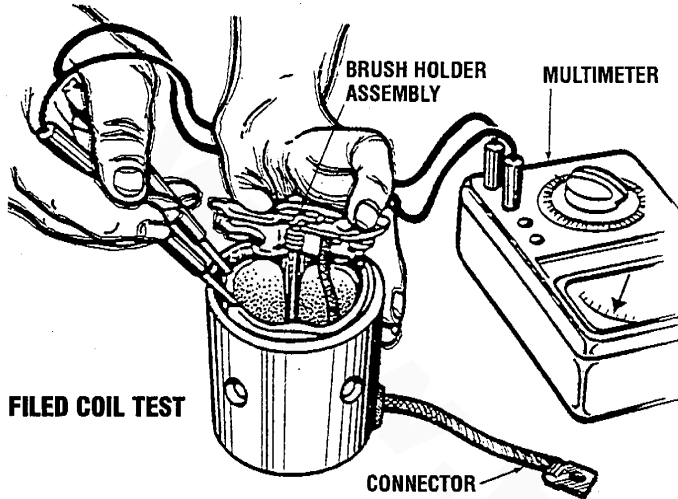

STARTER ADJUSTMENT AND REASSEMBLY

CAUTION: Before installing, thoroughly clean the starter flange and mounting surfaces, remove all oil, old paint, and rust. Starter performance largely depends on the quality of the wiring. Use wire of sufficient size and grade between the battery and starter and fully tighten to the terminal.

Reassemble the starter assembly in the reverse order of disassembly, making sure of the following:

1. **Pinion shaft end play adjustment.** Set the end play (thrust gap) to between 0.0197 - 0.0788in (0.5 to 2mm) by inserting an adjusting washer between the center bracket and the reduction gear.
 - a. Fit the pinion shaft, reduction gear washer and snap ring to the center bracket.
 - b. Measure end play by moving the pinion shaft in the axial direction. If the end play exceeds 0.0788in (0.5mm), increase the number of adjusting washers inserted.

2. **Greasing.** Whenever the starter has been overhauled, apply grease to the following parts:
 - a. Armature shaft gear and reduction gear.
 - b. All bearings.
 - c. Bearing shaft washers and snap rings.
 - d. Bearing sleeves.
 - e. Pinion.
 - f. Sliding portion of lever.

CAUTION: Never smear the starter fitting surface, terminals, brushes, or commutator with grease.

3. After reassembly, check by conducting a no-load test again.

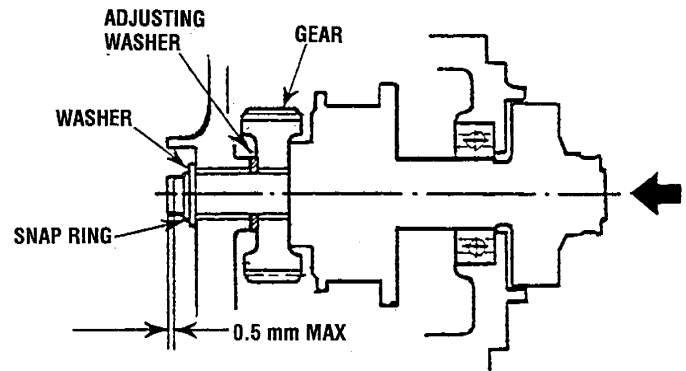

PINION SHAFT END PLAY

TACHOMETER/HOUR METER

The tachometer/hour meter used in propulsion engine instrument panels contains two separate electrical circuits with a common ground. One circuit operates the hour meter and the other the tachometer. The hour meter circuit operates on 12 volts alternator charging voltage supplied to the (+) terminal on the back of the instrument.

The tachometer circuit operates on AC voltage 6-8 volts, fed from one of the diodes in the alternator and supplied to the tachometer input terminal while the engine is running, and the alternator producing battery charging voltage 13.0-14.8 volts DC.

The following are procedures to follow when troubleshooting a fault in either of the two circuits in a tachometer/hour meter.

Hour meter Inoperative

Check for the proper DC voltage between (+) and (-) terminals.

1. Voltage present - meter is defective - repair or replace.
2. Voltage not present - trace (+) and (-) electrical connections for fault. (Jump 12 volts DC to meter (+) terminal to verify the operation.)

Tachometer Inoperative

Check for the proper AC voltage between tachometer input terminal and (-) terminal with the engine running.

1. Voltage present - attempt adjusting meter through calibration access hole. No results, repair or replace meter.
2. AC voltage not present - check for proper alternator DC output voltage.
3. Check for AC voltage at tach terminal on alternator to ground.
4. Check electrical connections from tachometer input terminal to alternator connection.

Tachometer Sticking

1. Check for proper AC voltage between "tach inp." terminal and (-) terminal.
2. Check for good ground connection between meter (-) terminal and alternator.
3. Check that alternator is well grounded to engine block at alternator pivot bolt.

Tachometer Inaccurate

- a. With a hand-held tach on the front of the crankshaft pulley retaining nut or with a strobe-type tach, read the front crankshaft pulley rpm at idle.
- b. Adjust the tachometer with a small Phillips type screwdriver through the calibration access hole in the rear of the tachometer. Zero the tach and bring it to the rpm indicated by the strobe or hand tach. (Verify the rpm at idle and at high speed 3000-3600 rpm). (Adjust the tach as needed.)

NOTE: Current model tachometers use a coarse adjustment dial to set the tachometer to the crankshaft pulley rpms. The calibrating screw is then used for fine tuning.

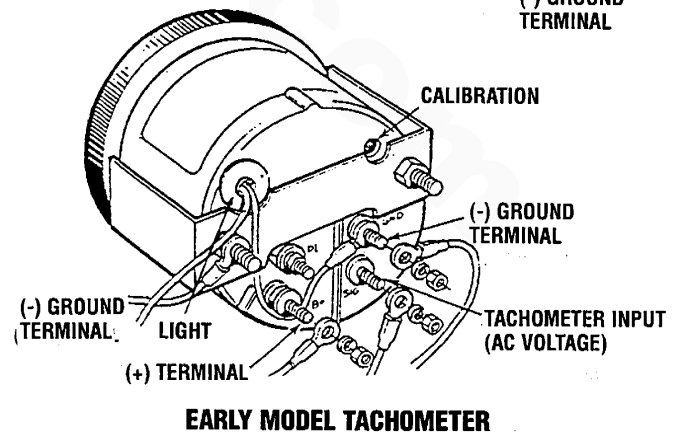
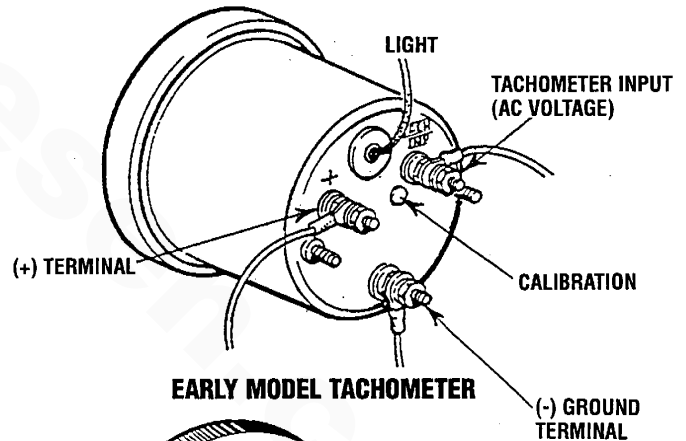
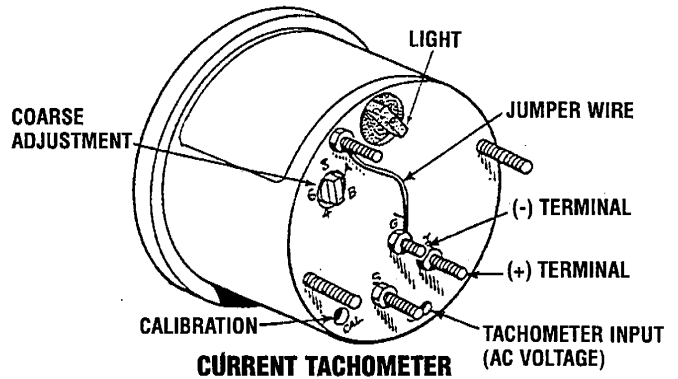

ALTERNATOR TESTING

DESCRIPTION

The charging system consists of an alternator with a voltage regulator, an engine DC wiring harness, a mounted DC circuit breaker and a battery with connecting cables. Because of the use of integrated circuits (IC's), the electronic voltage regulator is very compact and is mounted internally or on the back of the alternator.

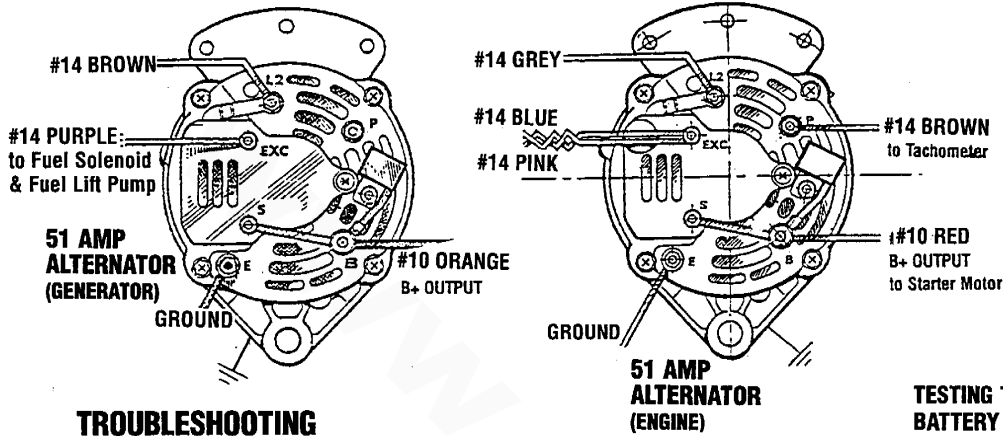

TROUBLESHOOTING

WARNING: A failed alternator can become very hot. Do not touch until the alternator has cooled down.

This troubleshooting section is to determine if a problem exists with the charging circuit or with the alternator. If it is determined that the alternator or voltage regulator is bad, it is best to have a qualified technician check it out.

The alternator charging circuit charges the starting battery and the service battery. An isolator with a diode, a solenoid, or a battery selector switch is usually mounted in the circuit to isolate the batteries so the service battery is not discharged along with the starting battery. If the alternator is charging the starting battery but not the service battery, the problem is in the service battery charging circuit and not with the alternator.

Testing the Alternator

WARNING: Before starting the engine make certain that everyone is clear of moving parts! Keep away from sheaves and belts during test procedures.

WARNING: MULTIMETERS AND DC CIRCUITS: DC and AC circuits are often mixed together in marine applications. Always disconnect shore power cords, isolate DC and AC converters and shut down generators before performing DC testing. No AC tests should be made without proper knowledge of AC circuits.

1. Start the Engine.
2. After a few minutes of running measure the starting battery voltage at the battery terminals using a multi-meter set on DC volts. The voltage should be increasing toward 14 volts. If it is, the alternator is working. Turn to Step 4.

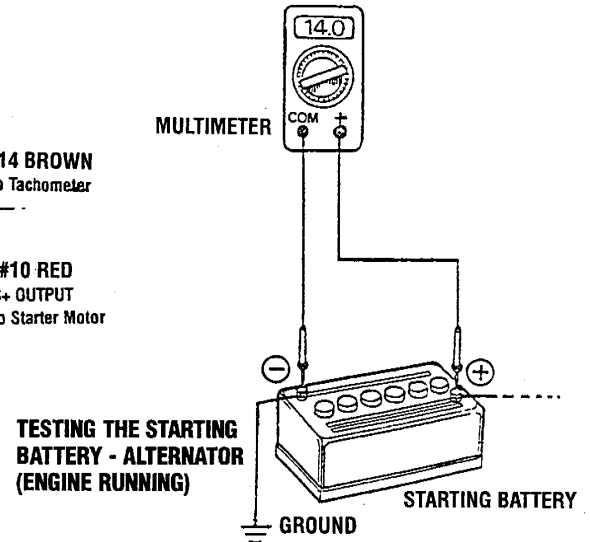

3. If the starting battery voltage remains around 12 volts after the engine is started and run for a few minutes, a problem exists with the alternator or the charging circuit.
 - a. Turn off the engine. Inspect all wiring and connections. Ensure that the battery terminals and the engine ground connections are tight and clean.
 - b. If a battery selector switch is in the charging circuit, ensure that it is on the correct setting.
 - c. Turn on the ignition switch, but do not start the engine.
 - d. Check the battery voltage. If your battery is in good condition the reading should be 12 to 13 volts.

CAUTION: To avoid damage to the battery charging circuit, never shut off the engine battery switch when the engine is running!

ALTERNATOR TESTING

- e. Now check the voltage between the alternator output terminal (B+) and ground. If the circuit is good, the voltage at the alternator should be the same as the battery, or if an isolator is in the circuit the alternator voltage will be zero. If not, a problem exists in the circuit between the alternator and the battery. Check all the connections - look for an opening in the charging circuit.

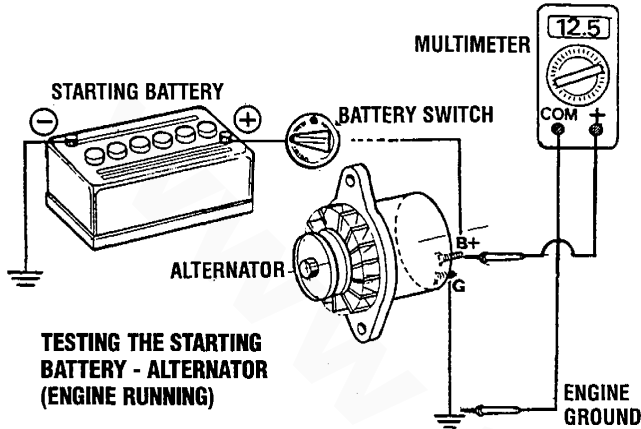

- f. Start the engine again. Check the voltage between the alternator output and ground. The voltage reading for a properly operating alternator should be between 13.5 and 14.5 volts. If your alternator is over- or under-charging, have it repaired at a reliable service shop.

NOTE: Before removing the alternator for repair, use a voltmeter to ensure that 12 volts DC excitation is present at the EXC terminal if the previous test showed only battery voltage at the B output terminal. If 12 volts are not present at the EXC terminal, trace the wiring looking for breaks and poor connections.

Jump the 12 V to the Exc. terminal from a known 12V source and operate the alternator. If the voltage output is 13-14 volts, the alternator is o.k. Trace the cause for 12 volts not present at the Exc. terminal.

Alternator is Working

4. Check the voltage of the service battery. This battery should have a voltage between 13 and 14 volts when the engine is running. If not, there is a problem in the service battery charging circuit. Troubleshoot the service battery charging circuit by checking the wiring and connections, the solenoid, isolator, battery switch and the battery itself.

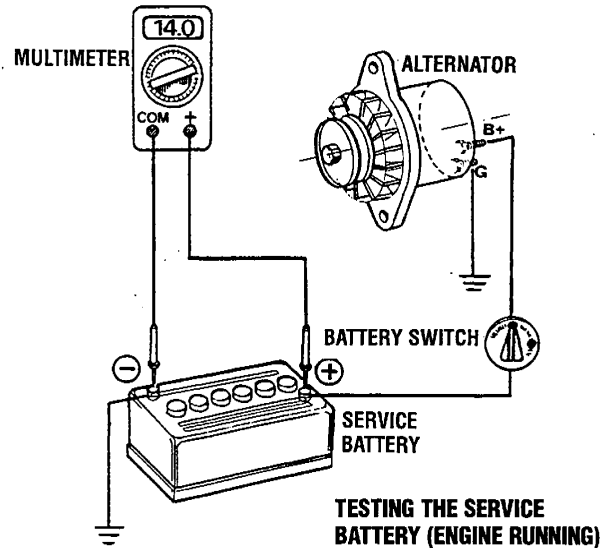

CAUTION: When performing tests on the alternator charging circuit do not use a high voltage tester (i.e. Megger). You can damage the alternator diodes.

ALTERNATOR INSPECTION

When rebuilding the engine, the alternator should be cleaned and inspected. The housing can be wiped off with a solvent and the alternator terminal studs should be cleaned with a wire brush. Make certain the studs are tight and clean the wiring connections that connect to the wiring harness.

Turn the rotor pulley by hand. It should turn smoothly.

Depending on when the alternator was last serviced, the brushes may need replacing. If the alternator is at all suspect, send it to a service shop for testing and overhaul.

82B FOUR MARINE ENGINE

WIRING DIAGRAM #039144

NOTE : An on-off switch should be installed in this circuit to disconnect the starter from the battery in an emergency and when leaving the boat. Twelve volt diesel engine starters typically draw 200 to 300 amps when cranking. A switch with a continuous rating of 175 amps at 12 VDC will normally serve this function, but a switch must never be used to "make" the starter circuit.

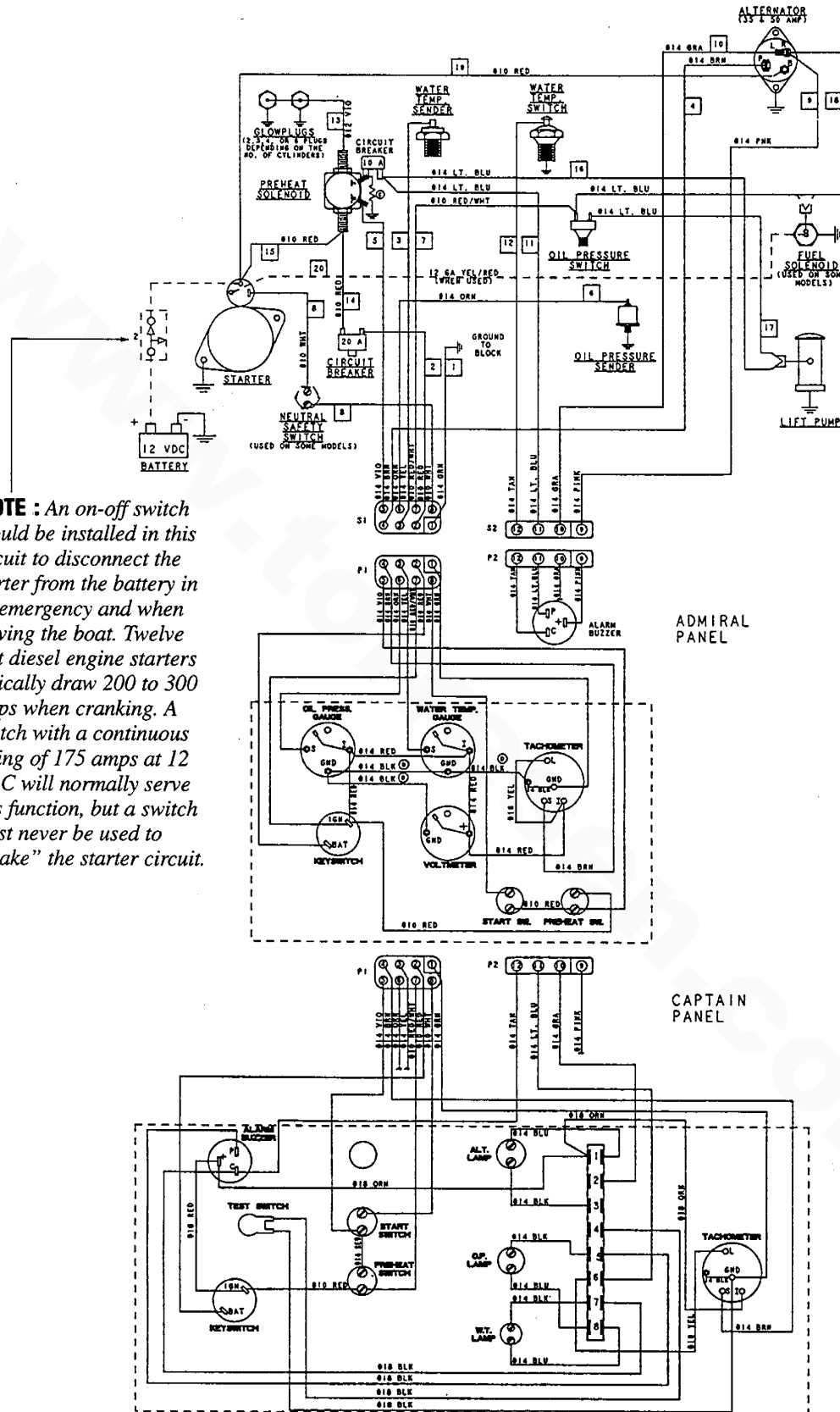

82B FOUR MARINE ENGINE

WIRING SCHEMATIC #039144

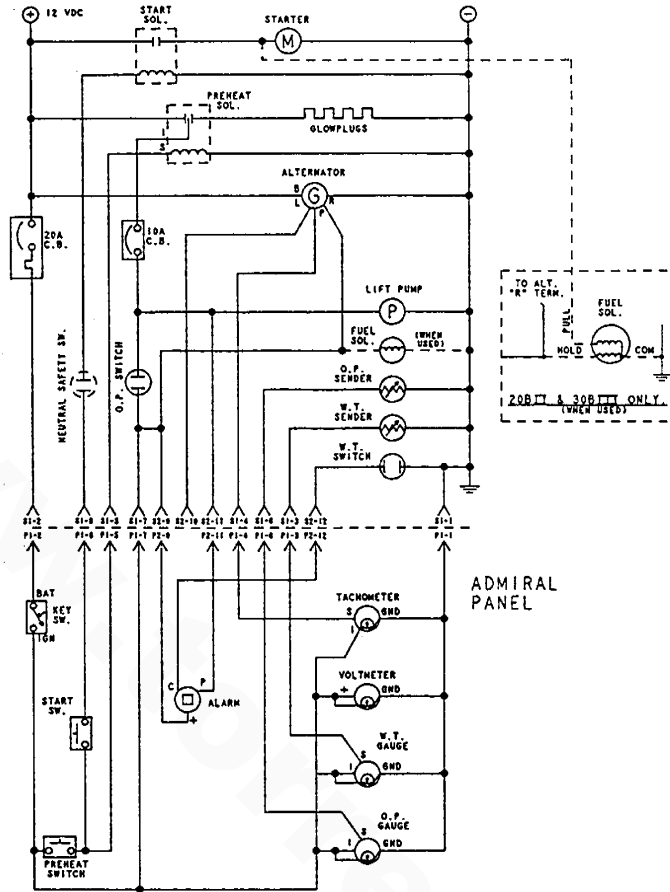

ADMIRAL PANEL

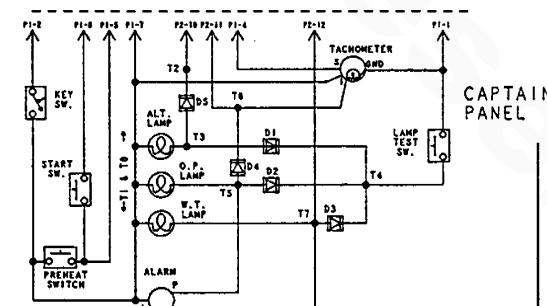

CAPTAIN PANEL

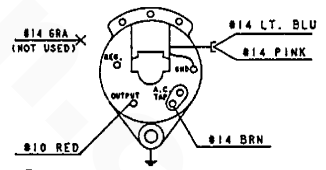

Ⓐ PRESTOLITE 72 AMP. ALT.

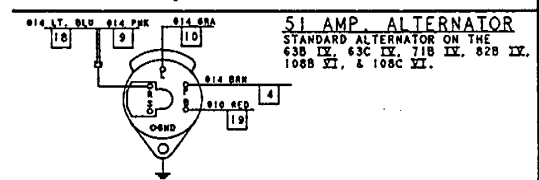

51 AMP. ALTERNATOR
STANDARD ALTERNATOR ON THE
63B IX, 63C IX, 71B IX, 82B IX,
108B VI, & 108C VI.

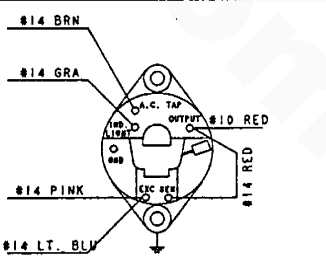
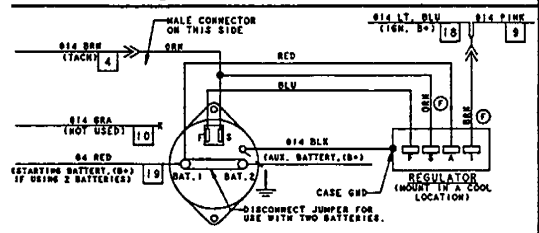

Ⓐ UNIVERSAL PROPULSION
PRESTOLITE 51 AMP. ALT.

OPTIONAL ALTERNATORS Ⓐ
135A, 160A, 190A, LESTER ALTERNATORS
AVAILABLE ON THE 63B IX, 63C IX, 71B IX, 82B IX, 108B VI, & 108C VI ONLY.



Engine parts from Torrsen Marine - www.torresen.com - 231-759-8596
SPECIFICATIONS - 82B FOUR MARINE ENGINE

ENGINE SPECIFICATIONS	
Engine Type	Diesel, four-cylinder, four-cycle, fresh water-cooled, vertical in-line overhead valve mechanism.
Aspiration	Naturally aspirated
Governor	Electronic Governing.
Combustion Chamber	Swirl type
Bore & Stroke	3.74 x 4.13 inches (95 x 105 mm)
Piston Displacement	182 cubic inches (2.98 liters)
Firing Order	1 - 3 - 4 - 2
Direction of Rotation	Clockwise, when viewed from the front
Compression Ratio	21 : 1
Dimensions	Height: 27.3 inches (694.0 mm) Width: 25.5 inches (647.7 mm) Length: 38.8 inches (985.8 mm)
Weight	678 lbs (307 kgs)
Inclination	Continuous 15° Temporary 25° (not to exceed 20 min.)
Generator Power Take Off	40 HP (Maximum)

TUNE-UP SPECIFICATIONS	
Compression Pressure (Limit of difference between cylinders)	427 psi (30 kg/cm ²) at 200 rpm (47.2 psi (3.0 kg/cm ²))
Valve Timing	Intake Opens 17° BTDC Intake Closes 47° ABDC Exhaust Opens 51° BBDC Exhaust Closes 13° ATDC
Valve Seat Angle	Intake 45° Exhaust 30°
Valve Clearance (engine warm)	Intake 0.012 inches (0.3 mm) Exhaust 0.012 inches (0.3 mm)
Injector Pressure	1920 + 71 - 0 psi (135 + 5 - 0 kg/cm ²)
Engine Timing	Static timed - drop valve method 0.205 ± .005 inches BTDC

EXHAUST EMISSIONS SYSTEMS	
Emission Control Systems	Indirect Fuel Injection

FUEL SYSTEM	
General	Open flow, self priming - 1 bleed point.
Fuel	No. 2 diesel oil (cetane rating of 45 or higher)
Fuel Injection Pump	ZEXEL Model VE Distributor (Diesel KiKi)
Fuel Injection Timing	0° TDC (Top Dead Center)
Nozzle	Throttle type
Fuel Filter (on engine)	Spin-on type, full flow
Air cleaner	Metal screen type - cleanable
Air Flow (engine combustion)	94.6 cfm (2.7 cmm)

COOLING SYSTEM	
General	Fresh water-cooled block, thermostatically-controlled with heat exchanger.
Operating Temperature	170 - 190° F (77 - 88° C)
Fresh Water Pump	Centrifugal type, metal impeller, belt-driven
Raw Water Pump	Positive displacement, rubber impeller, belt-driven.
Raw Water Flow, at 3600 rpm	19.0 gpm (71.9 lpm) (measured before discharging into exhaust elbow).
System Capacity (coolant)	13.0 qts (12.3 liters)

LUBRICATION SYSTEM	
General	Pressure fed system
Oil Filter	Full flow, paper element, spin-on type
Sump Capacity (not including filter)	6.5 U.S. qts (6.15liters) plus filter/cooler assembly
Operating Oil Pressure (engine hot)	50 - 60 psi (3.5 - 4.2 kg/cm ²)
Oil Grade	API Specification CF or CG-4, SAE 30, 10W-30, 15W-40

ELECTRICAL SYSTEM	
Starting Battery	12-Volt, (-) negative ground
Battery Capacity	400 - 600 Cold Cranking Amps (CCA)
Starter	12-Volt, reduction
Starting Aid	Glow plugs, sheathed type
Battery Charging Alternator	51 Amps



Engine parts from Torrsen Marine - www.torresen.com - 231-759-8596

SERVICE DATA / STANDARDS AND LIMITS - 82B FOUR MARINE ENGINE

Component	Specified Value / Standard inches(mm)	Repair Limit inches(mm)
COMPRESSION / TIMING		
Cylinder Compression Pressure	427 psi at 200 rpm (30.0 kg/cm ²)	384 psi (27.0 kg/cm ²)
Difference between Cylinders (Max)	42.7 psi (3.0 kg/cm ²)	
VALVE TIMING		
Intake Valve Opens	17° BTDC	
Intake Valve Closes	47° ABDC	
Exhaust Valve Opens	51° BBDC	
Exhaust Valve Closes	13° ATDC	
CYLINDER HEAD		
Surface Distortion	See Text	0.004 (0.1)
Intake Valve Seat Angle	45°	
Exhaust Valve Seat Angle	30°	
Intake Valve Seat Width	0.079 (2.0)	0.004 (0.1)
Exhaust Valve Seat Width	0.079 (2.0)	0.004 (0.1)
Valve Clearance (Intake & Exhaust)	0.012 (0.30) [cold]	
VALVES		
Valve Head Diameter (Intake)	1.59 - 1.60 (40.4 - 40.6)	
(Exhaust)	1.47 - 1.48 (37.40 - 37.60)	
Valve Head Thickness (Intake & Exhaust)	0.059 (1.5) ... 0.039 (1.0)	
Overall Length (Intake)	4.508 (114.5)	
(Exhaust)	4.512 (114.6)	
Valve Stem O.D. Intake	0.353 - 0.354 (8.955 - 8.980)	0.351 (8.904)
Exhaust	0.352 - 0.353 (8.935 - 8.960)	0.350 (8.884)
Valve Guide Protrusion from Cylinder Head	0.65 (16.5)	
Cylinder Inner Dia.	0.355 - 0.356 (9.018 - 9.040)	
Stem to Guide Clearance Intake	0.0015 - 0.0033 (0.038 - 0.085)	0.0050 (0.127)
Exhaust	0.0023 - 0.0041 (0.058 - 0.105)	0.0050 (0.127)
Valve Contact Width	0.079 (2.0)	
Valve Face Angle Intake	45°	
Exhaust	30°	
Dimension L (Sinking)	1.890 (48.0)	1.949 (49.5)
Valve Spring (Outer) Wire Diameter	0.117 (4.5)	
Outer Coil Diameter	1.496 (38.0)	
Free Length	2.193 (55.7)	2.083 (52.9)
Fitting Length	1.587 (40.3)	
Fitting Load	71.43 - 75.40lb (32.4 - 34.2Kg)	66.36lb (30.1Kg)
Squareness	0.054 (1.37)	
Spring Constant	121lb/in (2.16Kg/mm)	

Component	Specified Value / Standard inches(mm)	Repair Limit inches(mm)
Valve Spring (Inner)		
Wire Diameter	0.138 (3.5)	
Outer Coil Diameter	1.083 (27.5)	
Free Length	1.736 (44.1)	1.654 (42.0)
Fitting Length	1.488 (37.8)	
Fitting Load	26.68 - 29.32lb (12.1 - 13.3Kg)	24.92 lb/11.3 kg
Squareness	0.049 (1.25)	
Spring Constant	113lb/in (2.02Kg/mm)	
TIMING GEARS		
Backlash Between Gears in Mesh	0.0003 - 0.0005 (0.01 - 0.14)	0.012 (0.3)
Idler Gear Bushing Clearance Between Bushings and Shaft	0.001 - 0.010 (0.03 - 0.07)	0.0078 (0.2)
ROCKER ARM		
Rocker Arm Bore	0.625 - 0.626 (15.876 - 15.896)	
Rocker Arm Shaft Outer Diameter	0.6234 - 0.6244 (15.835 - 15.860)	
Clearance	0.0006 - 0.0024 (0.016 - 0.061)	0.0028 (0.07)
TAPPET		
Outer Diameter	0.5600 - 0.5610 (14.224 - 14.249)	
Bore in Cylinder Block	0.5630 - 0.5640 (14.288 - 14.319)	
Clearance In Cylinder Block Bore	0.0015 - 0.0037 (0.039 - 0.095)	0.0039 (0.10)
VALVE CAMSHAFT		
Journal Diameter No. 1 (Front)	2.0437 - 2.0449 (51.910 - 51.940)	
No. 2	2.0339 - 2.0351 (51.660 - 51.690)	
No. 3	2.0240 - 2.0250 (51.410 - 51.440)	
No. 4 (Rear)	2.0142 - 2.0154 (51.160 - 51.190)	
Wear Limit	0.0003 (0.008)	
Cam Elevation Intake and Exhaust	1.6767 (42.580)	1.6728 (42.478)
Camshaft End Play	0.0008 - 0.0071 (0.020 - 0.180)	0.0118 (0.30)
Camshaft Run-Out	0.08 (0.0031)	
Camshaft Support Bore No. 1 (Front)	2.0473 - 2.0485 (52.000 - 52.030)	
No. 2	2.0374 - 2.0386 (51.750 - 51.780)	
No. 3	2.0280 - 2.0290 (51.500 - 51.530)	
No. 4 (Rear)	2.0177 - 2.0189 (51.250 - 51.280)	
Oil Clearance	0.0024 - 0.0047 (0.060 - 0.120)	0.0057 (0.145)
Backlash Between Gears	0.0039 - 0.0067 (0.10 - 0.17)	0.0118 (0.30)
IDLER GEAR		
Boss Bore	1.8898 - 1.8908 (48.000 - 48.025)	
Boss Bore Limit	0.0079 - 0.0118 (0.20 - 0.30)	
Bushing Inner Diameter	1.7327 - 1.7336 (44.009 - 44.034)	
Outer Diameter	1.8915 - 1.8925 (48.043 - 48.068)	
Spindle Length	1.1398 - 1.1437 (28.95 - 29.05)	
Outer Diameter	1.7303 - 1.7313 (43.950 - 43.975)	
Spindle and Bushings Clearance	0.0013 - 0.0033 (0.034 - 0.084)	0.0059 (0.15)
End Play	0.0059 - 0.0118 (0.15 - 0.28)	



SERVICE DATA / STANDARDS AND LIMITS - 82B FOUR MARINE ENGINE

Component	Specified Value / Standard inches(mm)	Repair Limit inches(mm)
CONNECTING ROD		
Small End Bore		
Piston Pin and Small End Bushing	0.005 - 0.0015 (0.012 - 0.039)	0.0020 (0.05)
Bend and Twist	0.002 in 4 (0.05 in 100)	
Side Clearance	0.0094 - 0.0134 (0.239 - 0.340)	0.0157 (0.40)
Small End Bore	1.1816 - 1.1824 (30.012 - 30.033)	
CONNECTING ROD BEARING		
Oil Clearance	0.0014 - 0.0030 (0.036 - 0.076)	0.039 (0.10)
Available Undersize	0.01, 0.02, 0.03 (0.255, 0.508, 0.762)	
PISTON		
Diameter	3.7381 - 3.7399 (94.967 - 94.993)	
Piston Ring Hole Bore	1.1809 - 1.1814 (29.996 - 30.008)	
Ring Groove Width		
Top	0.0958 - 0.966 (2.433 - 2.453)	
Second	0.0954 - 0.962 (2.423 - 2.443)	
Oil	0.1887 - 0.1895 (4.793 - 4.813)	
PISTON RINGS		
Piston/Liner Clearance	0.0017 - 0.0028 (0.032 - 0.083)	
Width		
Top	0.0958 - 0.0966 (2.433-2.453)	
Second	0.0954 - 0.0962 (2.423 - 2.443)	
Oil	0.1887 - 0.1895 (4.793 - 4.813)	
Thickness		
Top	0.0930 - 0.938 (2.363 - 2.383)	
Second	0.0930 - 0.938 (2.363 - 2.383)	
Oil	0.1867 - 0.1875 (4.743 - 4.763)	
Side Clearance		
Top	0.0020 - 0.0070 (0.050 - 0.180)	0.118 (0.30)
Second	0.0016 - 0.0031 (0.040 - 0.080)	
Oil	0.0012 - 0.0028 (0.030 - 0.070)	
End Gap	0.0157 - 0.0240 (0.40 - 0.60)	0.0591 (1.5)
PISTON PIN		
Diameter	1.1809 - 1.1811 (29.994 - 30.000)	
Pin to Piston Clearance	0 - 0.006 (0 - 0.016)	
CRANKSHAFT		
Main Journal diameter	2.9848 - 2.9853 (75.812 - 75.825)	
Grinding Limit	2.955 (75.05)	
Crankpin Diameter	2.4060 - 2.4065 (61.112 - 61.125)	
Processing Diameter	0.030 (0.762)	
End Play	0.0055 - 0.0154 (0.140 - 0.390)	0.0157 (0.40)
Run-out		0.0020 (0.05)

Component	Specified Value / Standard inches(mm)	Repair Limit inches(mm)
MAIN BEARING		
Clearance	0.0020 - 0.0037 (0.059 - 0.090)	0.0047 (0.12)
Available Undersize	0.01, 0.02, 0.03 (0.254, 0.508, 0.762)	
CYLINDER BLOCK		
Warpage limit	0.004 (0.10)	
Cylinder Liner		
Inner Diameter	3.7412 - 3.7422 (95.025 - 95.050)	0.0079 (0.20)
Protrusion	-0.0040 - -0.0000 (-0.101 - -0.000)	
Flywheel to Crankshaft Run-out		0.0079 (0.20)
FUEL SYSTEM		
Idle Speed	600 - 650 rpm	
Fuel Injection Pump		
Plunger diameter	0.393 (10.0)	
Cam Lift	0.08 (2.2)	
Injection Timing	0° T.D.C.	
Injector Nozzle Diameter	0.031 (0.80)	
Injection Order	1 - 3 - 4 - 2	
Injection Pressure	1920 + 71/-0 psi (135 + 5/-0 kg/cm ²)	
LUBRICATION SYSTEM		
Oil Pressure	54 psi (3.8 kg/cm ²)	
Min Safe pressure (idle)	4.3 ± 1.4 psi (0.3 ± 0.1 kg/cm ²)	
Oil Capacity (sump)	6.3 Qts (6.0 L)	
Oil Pump		
Outer Rotor and Body Clearance	0.0055 - 0.0100 (0.14 - 0.25)	0.0118 (0.30)
Rotor Lobe Clearance	0.0016 - 0.0059 (0.04 - 0.15)	0.0118 (0.30)
Rotor End Float	0.0016 - 0.0039 (0.04 - 0.10)	0.0059 (0.15)
Pump Shaft and Body Clearance	0.0024 - 0.0079 (0.06 - 0.15)	0.0039 (0.10)
STARTER MOTOR		
Depth of Brush Undercut	0.019 (0.5)	0.008 (0.2)
Height of Brush	0.669 (17)	0.236 (6)
Spring Pressure	43 lb/in ² (3 kg/cm ²)	
Commutator O.D.	1.523 (38.7)	-0.039 (-1.0)
Pinion Shaft End Play	0.0197 (0.5)	



Engine parts from Torrsen Marine - www.torresen.com - 231-759-8596
TORQUE SPECIFICATIONS - 82B FOUR MARINE ENGINE

COMPONENT	FT-LB (M-KG)	COMPONENT	FT-LB (M-KG)
Alternator Bracket	27 - 38 (3.8 - 5.3)	Injection Pipe Flare Nut.....	18 - 22 (1.6 - 3.0)
Back Plate	24 - 35 (3.3 - 4.8)	Injection Pump Gear Locknut.....	29 - 51 (4.0 - 7.0)
Camshaft Gear	46 - 69 (6.4 - 9.5)	Injector to Head	43 - 51 (6.0 - 7.0)
Camshaft Thrust Plate.....	12 - 17 (1.6 - 2.4)	Intake Manifold	12 - 17 (1.6 - 2.4)
Connecting Rod Cap	59 - 65 (8.2 - 9.0)	Main Bearing Cap	79.56 - 80.29 (11.0 - 11.7)
Coolant Pump	12 - 17 (1.6 - 2.4)	Oil Pan	12 - 17(1.6- 2.3)
Coolant Pump Pulley.....	12 - 17 (1.6 - 2.4)	Oil Pan Pipe	12 - 17 (1.6 - 2.3)
Coolant Temperature Sender	9 - 13 (1.2 - 1.8)	Oil Pressure Sender	9 - 13 (1.2 - 1.8)
Coolant Temperature Switch.....	9 - 13 (1.2 - 1.8)	Oil Pressure Switch.....	9 - 13 (1.2 - 1.8)
Crankshaft Pulley Nut	253 - 289 (35.0 - 40.0)	Oil Pump Cover	6 - 9 (0.8 - 1.2)
Cylinder Head Bolts.....	85 - 90 (11.8 - 12.5)	Oil Pump Pipe	6 - 9 (0.8 - 1.2)
Cylinder Head Cover	2 - 3 (0.3 - 0.45)	Rear Oil Seal Cap.....	11 - 15 (1.5 - 2.0)
Damper Plate.....	14 - 20 (1.9 - 2.7)	Rocker Arm Assembly	80 - 85 (11.0 - 11.7)
Engine Mounts	23 - 34 (3.2 - 4.7)	Rocker Arm Cover.....	1.8 - 2.9 (0.25 - 0.40)
Fuel Filter Assembly	33 49 (4.6 - 6.8)	Thermostat Housing	2 - 3 (0.3 - 0.45)
Exhaust Manifold.....	12 - 17 (1.6 - 2.4)	Thrust Plate	16 - 23 (2.3 - 3.2)
Fuel Solenoid Locknut	28.9 - 36.2 (4.0 - 5.0)	Timing Gear Case	12 - 17 (1.6 - 2.4)
Flywheel Bolt	95 - 137 (13.1 - 19.0)	Timing Gear Cover.....	12 - 17 (1.6 - 2.4)
Glow Plug	7 - 11 (1.0 - 1.5)		
Idler Gear	17 - 23 (2.2 - 3.2)		
Injection Nozzle to Body	8 - 10 (1.1 - 2.0)		



STANDARD HARDWARE

BOLT HEAD MARKINGS

Bolt strength classes are embossed on the head of each bolt.

Customary (inch) bolts are identified by markings two to grade eight (strongest). The marks correspond to two marks less than the actual grade, i.e.; a grade seven bolt will display five embossed marks.

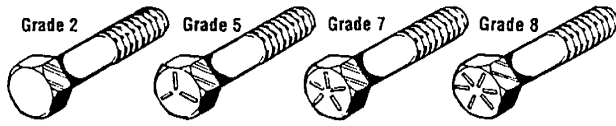

Metric bolt class numbers identify bolts by their strength with 10.9 the strongest.

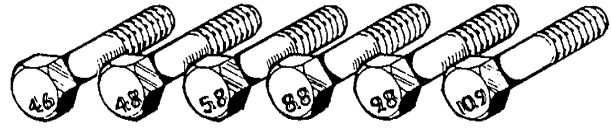

- NOTES:**
1. Use the torque values listed below when specific torque values are not available.
 2. These torques are based on clean, dry threads. Reduce torque by 10% when engine oil is used.
 3. Reduce torques by 30% or more, when threading capscrews into aluminum.

STANDARD BOLT & NUT TORQUE SPECIFICATIONS			
Capscrew Body Size (Inches) - (Thread)	SAE Grade 5 Torque Ft-Lb (Nm)	SAE Grade 6-7 Torque Ft-Lb (Nm)	SAE Grade 8 Torque Ft-Lb (Nm)
1/4 - 20 - 28	8 (11) 10 (14)	10 (14)	12 (16) 14 (19)
5/16 - 18 - 24	17 (23) 19 (26)	19 (26)	24 (33) 27 (37)
3/8 - 16 - 24	31 (42) 35 (47)	34 (46)	44 (60) 49 (66)
7/16 - 14 - 20	49 (66) 55 (75)	55 (75)	70 (95) 78 (106)
1/2 - 13 - 20	75 (102) 85 (115)	85 (115)	105 (142) 120 (163)
9/16 - 12 - 18	110 (149) 120 (163)	120 (163)	155 (210) 170 (231)
5/8 - 11 - 18	150 (203) 170 (231)	167 (226)	210 (285) 240 (325)
3/4 - 10 - 16	270 (366) 295 (400)	280 (380)	375 (508) 420 (569)
7/8 - 9 - 14	395 (536) 435 (590)	440 (597)	605 (820) 675 (915)
1 - 8 - 14	590 (800) 660 (895)	660 (895)	910 (1234) 990 (1342)

METRIC BOLT & NUT TORQUE SPECIFICATIONS					
Bolt Dia.	Wrench Size	Grade 4.6 Ft-Lb (Nm)	Grade 4.8 Ft-Lb (Nm)	Grade 8.8 - 9.8 Ft-Lb (Nm)	Grade 10.9 Ft-Lb (Nm)
M3 M4 M5	5.5 mm 7 mm 8 mm	0.3 (0.5) 0.8 (1.1) 1.5 (2.5)	0.5 (0.7) 1 (1.5) 2 (3)	1 (1.3) 2 (3) 4.5 (6)	1.5 (2) 3 (4.5) 6.5 (9)
M8 M9 M10	10 mm 13 mm 16 mm	3 (4) 7 (9.5) 14 (19)	4 (5.5) 10 (13) 18 (25)	7.5 (10) 18 (25) 37 (50)	11 (15) 35 (26) 55 (75)
M12 M14 M16	18 mm 21 mm 24 mm	26 (35) 37 (50) 59 (80)	33 (45) 55 (75) 85 (115)	63 (85) 103 (140) 159 (215)	97 (130) 151 (205) 232 (315)
M18 M20 M22	27 mm 30 mm 33 mm	81 (110) 118 (160) 159 (215)	118 (160) 166 (225) 225 (305)	225 (305) 321 (435) 435 (590)	321 (435) 457 (620) 620 (840)
M24 M27 M30	36 mm 41 mm 46 mm	203 (275) 295 (400) 402 (545)	288 (390) 417 (565) 568 (770)	553 (750) 811 (1100) 1103 (1495)	789 (1070) 1154 (1565) 1571 (2130)
M33 M36	51 mm 55 mm	546 (740) 700 (950)	774 (1050) 992 (1345)	1500 (2035) 1925 (2610)	2139 (2900) 2744 (3720)

NOTE: Formula to convert Ft-Lbs to Nm (Newton Meters) multiply Ft-Lb x 1.356.

SEALANTS & LUBRICANTS

GASKETS/SEALANTS

Oil based PERMATEX #2 and it's HIGH TACK equivalent are excellent all purpose sealers. They are effective in just about any joint in contact with coolant, raw water, oil or fuel.

A light coating of OIL or LIQUID TEFLON can be used on rubber gaskets and O-rings.

LOCTITE hydraulic red sealant should be used on oil adapter hoses and the oil filter assembly.

Coat both surfaces of the oil pan gasket with high temp RED SILICONE sealer.

When installing gaskets that seal around water (coolant) passages, coat both sides with WHITE SILICONE grease.

High-copper ADHESIVE SPRAYS are useful for holding gaskets in position during assembly.

Specialized gasket sealers such as HYLOMAR work well in applications requiring non-hardening properties. HYLOMAR is particularly effective on copper cylinder-head gaskets as it resists fuel, oil and water.

Use LIQUID TEFLON for sealing pipe plugs and fillings that connect coolant passages. **Do not use tape sealants!**

BOLTS & FASTENERS/ASSEMBLIES

Lightly oil head bolts and other fasteners as you assemble them. Bolts and plugs that penetrate the water jacket should be sealed with PERMATEX #2 or HIGH TACK.

When assembling the flywheel, coat the bolt threads with LOCTITE blue.

Anti-seize compounds and thread locking adhesives such as LOCTITE protect threaded components yet allows them to come apart when necessary. LOCTITE offers levels of locking according to the job.

LITHIUM based grease is waterproof, ideal for water pump bearings and stuffing boxes.

Heavily oil all sliding and reciprocating components when assembling. **Always use clean engine oil!**



GENERATOR INFORMATION

USE OF ELECTRIC MOTORS

The power required to start an electric motor is considerably more than is required to keep it running after it is started. Some motors require much more current to start them than others. Split-phase (AC) motors require more current to start, under similar circumstances, than other types. They are commonly used on easy-starting loads, such as washing machines, or where loads are applied after the motor is started, such as small power tools. Because they require 5 to 7 times as much current to start as to run, their use should be avoided, whenever possible, if the electric motor is to be driven by a small generator. Capacitor and repulsion-induction motors require from 2 to 4 times as much current to start as to run. The current required to start any motor varies with the load connected to it. An electric motor connected to an air compressor, for example, will require more current than a motor to which no load is connected.

In general, the current required to start 115-Volt motors connected to medium starting loads will be approximately as follows:

MOTOR SIZE (HP)	AMPS FOR RUNNING (AMPERES)	AMPS FOR STARTING (AMPERES)
1/6	3.2	6.4 to 22.4*
1/4	4.6	9.2 to 32.2*
1/3	5.2	10.4 to 72.8*
1/2	7.2	14.4 to 29.2*
3/4	10.2	20.4 to 40.8*
1	13	26 to 52

***NOTE:** In the above table the maximum Amps for Starting is more for some small motors than for larger ones. The reason for this is that the hardest starting types (split-phase) are not made in larger sizes.

Because the heavy surge of current needed for starting motors is required for only an instant, the generator will not be damaged if it can bring the motor up to speed in a few seconds. If difficulty is experienced in starting motors, turn off all other electrical loads and, if possible, reduce the load on the electric motor.

Required Operating Speed

Run the generator first with no load applied, then at half the generator's capacity, and finally loaded to its full capacity as indicated on the generator's data plate. The output voltage should be checked periodically to ensure proper operation of the generating plant and the appliances it supplies. If an AC voltmeter or ampmeter is not installed to monitor voltage and load, check it with a portable meter and ampprobe.

NOTE: When the vessel in which the generator is installed contains AC equipment of 120 volts only, it is recommended that the generator's AC terminal block be configured to provide one 120 volt AC hot leg for the vessel's distribution panel. This will ensure good motor starting response from the generator.

Generator Frequency Adjustment

Frequency is a direct result of engine/generator speed, as indicated by the following:

- When the generator is run at 1800 rpm, the AC voltage output frequency is 60 Hertz.
- When the generator is run at 1500 rpm, the AC voltage output frequency is 50 Hertz.

Therefore, to change the generator's frequency, the generator's drive engine's speed must be changed. Along with a reconfiguring of the AC output connections at the generator, a regulator board voltage output adjustment must also be made. See *ELECTRONIC GOVERNOR* in this manual.

Generator Maintenance

- Maintaining reasonable cleanliness is important. Connections of terminal boards and rectifiers may become corroded, and insulation surfaces may start conducting if salts, dust, engine exhaust, carbon, etc. are allowed to build up. Clogged ventilation openings may cause excessive heating and reduced life of windings.
- For unusually severe conditions, thin rust-inhibiting petroleum-base coatings, should be sprayed or brushed over all surfaces to reduce rusting and corrosion.
- In addition to periodic cleaning, the generator should be inspected for tightness of all connections, evidence of overheated terminals and loose or damaged wires.
- The drive discs on single bearing generators should be checked periodically if possible for tightness of screws and for any evidence of incipient cracking failure. Discs should not be allowed to become rusty because rust may accelerate cracking. The bolts which fasten the drive disc to the generator shaft must be hardened steel SAE grade 8, identified by 6 radial marks, one at each of the 6 corners of the head.
- The rear armature bearing is lubricated and sealed; no maintenance is required. However, if the bearing becomes noisy or rough-sounding, have it replaced.
- Examine bearing at periodic intervals. No side movement of shaft should be detected when force is applied. If side motion is detectable, bearings are wearing or wear on shaft of bearing socket outside bearing has occurred. Repair must be made quickly or major components will rub and cause major damage to generator.

Carbon Monoxide Detector

WESTERBEKE recommends mounting a carbon monoxide detector in the vessels living quarters. **Carbon monoxide, even in small amounts is deadly.**

The presence of carbon monoxide indicates an exhaust leak from the engine or generator, from the exhaust elbow/exhaust hose, or that fumes from a nearby vessel are entering your boat.

If carbon monoxide is present ventilate the area with clean air and correct the problem immediately!



GENERATOR CONTROL PANEL SWITCHES

DESCRIPTION

This manually controlled series of WESTERBEKE marine diesel generators is equipped with toggle switches on the engine control panel and, optionally, at remote panels. The following instructions and methods of correcting minor problems apply only to such toggle switch controls.

All three switches are momentary contact type and serve the following functions:

1. PREHEAT: The PREHEAT toggle switch is a double pole, single throw switch. The switch serves two purposes: preheating the engine for easy starting and defeating of bypassing the engine oil pressure switch. The defeat function turns on the fuel solenoid, instrument power and alternator excitation.

When the PREHEAT switch is depressed, the voltmeter, panel lights, gauges and meters and fuel solenoid will activate. The PREHEAT switch should be depressed for twenty seconds.

2. STOP: The STOP toggle switch is a single pole, single throw, normally closed switch. The switch provides power to the fuel solenoid, instrument cluster and alternator excitation, after the oil pressure switch has closed upon starting. Opening of this switch opens the power circuit to the fuel solenoid, stopping the flow of fuel to the engine and shuts down the engine.

To stop the engine, depress the STOP switch. When the STOP switch is depressed, the power feed to the fuel solenoid is opened, and the fuel flow to the engine is stopped. The STOP switch should be depressed until the generator stops rotating.

3. START: The START toggle switch is a double pole, single throw switch. The switch serves two purposes: starting the engine and defeating of bypassing the engine oil pressure switch. The defeat function turns on the fuel solenoid, instrument power and alternator excitation. While the PREHEAT switch is still depressed, depressing the START switch engages the start solenoid. Panel power and the fuel solenoid will be activated. When the engine begins to fire, the START switch should be released. The PREHEAT switch should not be released until the oil pressure reaches alarm stops.

NOTE: When the engine is shut down, the water temperature gauge and the oil pressure gauge will continue to register the last temperature and oil pressure readings displayed. They will return to zero once electrical power is restored.

4. EMERGENCY STOP: The EMERGENCY stop switch at the rear of the control box is normally closed. When depressed, it will open the DC circuit to the control panel and shut the engine down. As the switch is not toggled it can be used when performing maintenance.

REMOTE PANEL

For remote operation of the generator system, the same three switches are used. The PREHEAT and START switches are connected in parallel with the gauge panel's switches and serve the same functions as in the gauge panel. The STOP switch is in series with the gauge panel's STOP switch and serves the same function.

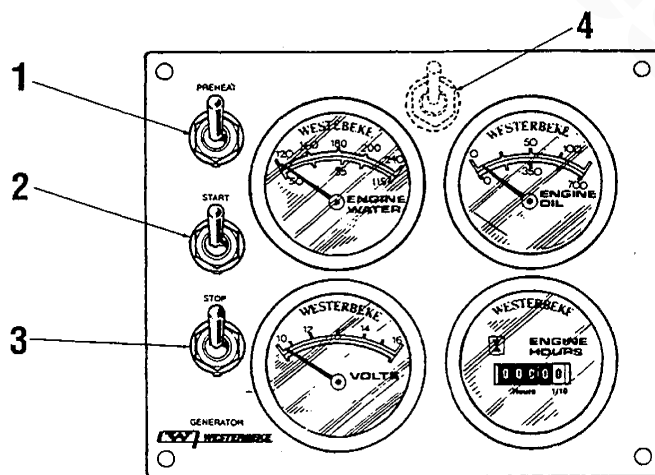

CONTROL PANEL

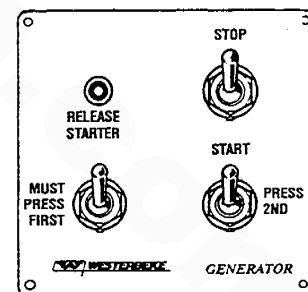

REMOTE PANEL (OPTIONAL)



CONTROL PANEL TROUBLESHOOTING MANUAL STARTER DISCONNECT (TOGGLE SWITCHES)

NOTE: The engine control system is protected by a 20 amp manual reset circuit breaker located on the engine as close as possible to the power source.

Problem	Probable Cause	Verification/Remedy
PREHEAT depressed, no panel indications electric fuel pump and preheat solenoid not energized. cuit	<ol style="list-style-type: none"> 1. Oil Pressure switch. 2. 20 amp circuit breaker tripped. 	<ol style="list-style-type: none"> 1. Check switches and/or battery connections. 2. Reset breaker. If it opens again, check preheat solenoid circuit and run circuit for shorts to ground.
START SWITCH DEPRESSED , no starter engagement.	<ol style="list-style-type: none"> 1. Connection to solenoid faulty. 2. Low DC voltage to solenoid terminal. 3. Faulty switch. 4. Faulty solenoid. 5. Loose battery connections. 6. Low battery. 	<ol style="list-style-type: none"> 1. Check connection. 2. Check voltage. Jump voltage to S terminal. 3. Check switch with ohmmeter. 4. Check that 12 volts are present at the solenoid connection. 5. Check battery connections. 6. Check battery charge state.
NO IGNITION , cranks, does not start.	<ol style="list-style-type: none"> 1. Faulty fueling system. 2. Check for air in the fuel system. 3. Faulty fuel lift pump. 4. Faulty fuel solenoid. 	<ol style="list-style-type: none"> 1. Check for fuel. 2. Allow system to bleed. 3. Replace fuel lift pump. 4. Check fuel solenoid.
NOT CHARGING BATTERY	<ol style="list-style-type: none"> 1. Faulty alternator drive. 	<ol style="list-style-type: none"> 1. Check the drive belt and its tension. Be sure the alternator turns freely. Check for loose connections. Check the output with a voltmeter. Ensure 12V are present at the regulator terminal.(Exc. Terminal.)
BATTERY RUNS DOWN	<ol style="list-style-type: none"> 1. Oil pressure switch. 2. High resistance leak to ground. 	<ol style="list-style-type: none"> 1. Observe if the gauges and panel lights are activated when the engine is not running. Test the oil pressure switch. 2. Check the wiring. Insert sensitive (0-.25 amp) meter in battery lines (Do NOT start engine). Remove connections and replace after short is located.

TROUBLESHOOTING WATER TEMPERATURE AND OIL PRESSURE GAUGES

If the gauge reading is other than what is normally indicated by the gauge when the instrument panel is energized, the first step is to check for 12 volts DC between the ignition (B+) and the Negative (B-) terminals of the gauge.

Assuming that there is 12 volts as required, leave the instrument panel energized and perform the following steps:

1. Disconnect the sender wire at the gauge and see if the gauge reads zero, which is the normal reading for this situation.
2. Connect the sender terminal at the gauge to ground and see if the gauge reads full scale, which is the normal reading for this situation.

If both of the above gauge tests are positive, the gauge is undoubtedly OK and the problem lies either with the conductor from the sender to the gauge or with the sender.

If either of the above gauge tests are negative, the gauge is probably defective and should be replaced.

Assuming the gauge is OK, check the conductor from the sender to the sender terminal at the gauge for continuity.

Check that the engine block is connected to the ground. Some starters have isolated ground terminals and if the battery is connected to the starter (both plus and minus terminals), the ground side will not necessarily be connected to the block.



THE BE GENERATOR SINGLE AND THREE PHASE

DESCRIPTION

This generator is a four-pole, brushless, self-excited generator which requires only the driving force of the engine to produce AC output. The copper and laminated iron in the exciter stator are responsible for the self-exciting feature of this generator. The magnetic field produced causes an AC voltage to be induced into the related exciter rotor windings during rotation. Diodes located in the exciter rotor rectify this voltage to DC and supply it to the windings of the rotating field. This creates an electromagnetic field which rotates through the windings of the main stator, inducing an AC voltage which is supplied to a load. An AC voltage is produced in the auxiliary windings of the main stator and is, in turn, supplied to a voltage regulator. The regulator produces a DC voltage to further excite the exciter stator windings, enabling the generator to produce a rated AC output. The voltage regulator senses AC voltage output and adjusts DC excitation to the exciter stator winding according to amperage load the generator is furnishing. To maintain a constant voltage output.

CIRCUIT BREAKER

A circuit breaker is installed on all WESTERBEKE generators. This circuit breaker will automatically disconnect generator power in case of an electrical overload. The circuit breaker can be manually shut off when servicing the generator to ensure that no power is coming into the boat.

NOTE: This circuit breaker is available as a WESTERBEKE add-on kit for earlier model generations; contact your WESTERBEKE dealer.

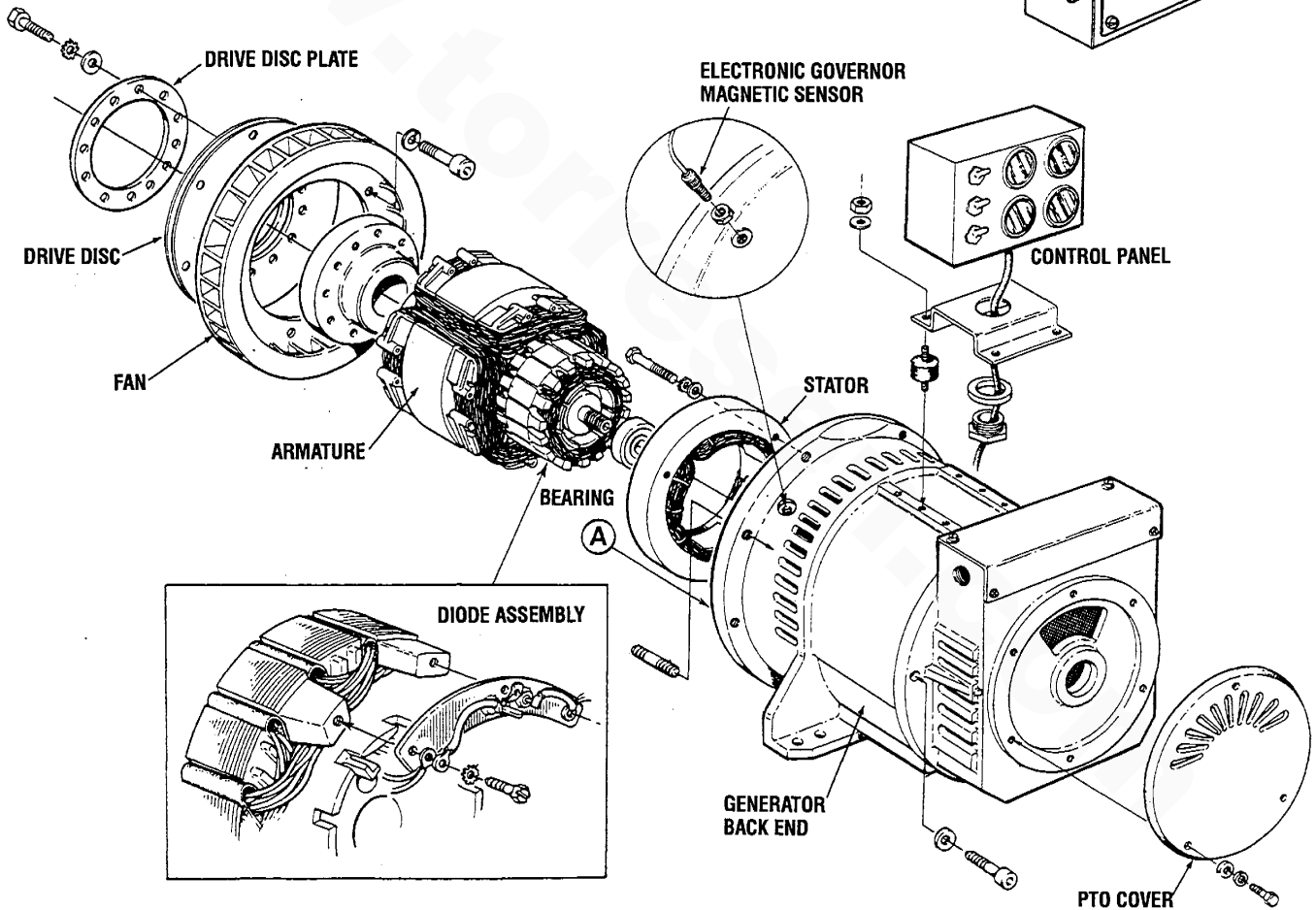
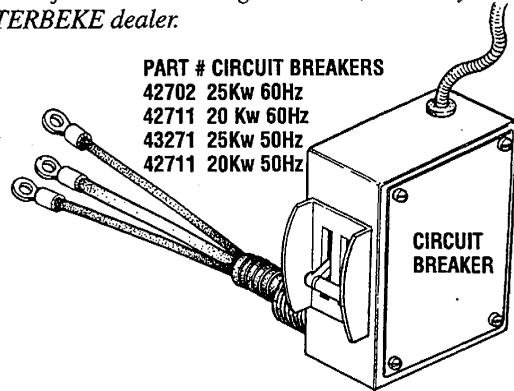

GENERATOR AC VOLTAGE CONNECTIONS

DESCRIPTION

The regulator is equipped with seven numbered terminals (0 to 6) and their related brass jumpers. The illustrations show connection points and jumpers for the 3 phase configuration of the generator. The sensing leads connect between pin #1 and pin #2 on the AC terminal block and connection #2 and #0 on the voltage regulator board.

NOTE: Series Delta requires the installation of a jumper on the regulator board between terminal B and 10.

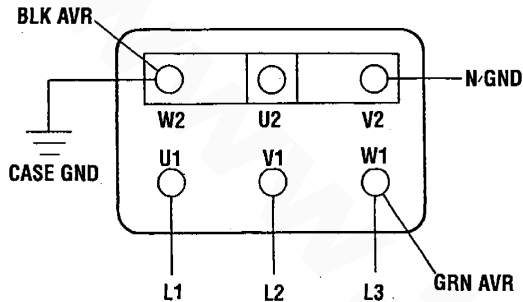

**BE THREE PHASE (SIX WIRE)
CONNECTIONS FOR BOTH 60 & 50 HERTZ**

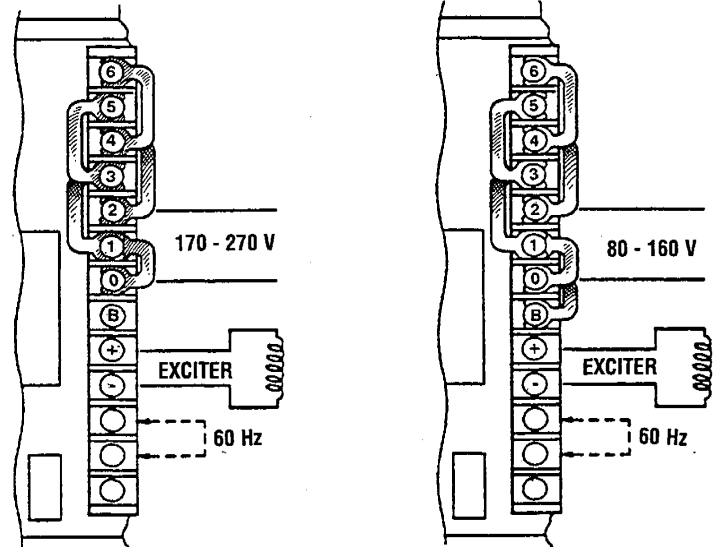

3 PHASE VOLTAGE REGULATOR

PARALLEL WYE (STAR)

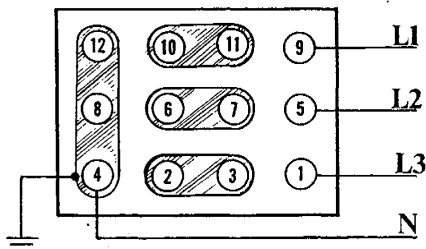

- L - L - 208 VAC 3Ø 50 Hz
- L - N - 120 VAC 1Ø 60 Hz
- L - L - 190 VAC 3Ø 50 Hz
- L - N - 110 VAC 1Ø 60 Hz

SERIES WYE (STAR)

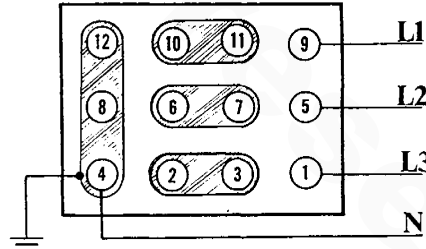

- L - L - 450 VAC 3Ø 60Hz
- L - N - 265 VAC 1Ø 60 Hz
- L - L - 380 VAC 3Ø 50Hz
- L - N - 220 VAC 1Ø 50Hz

SERIES DELTA

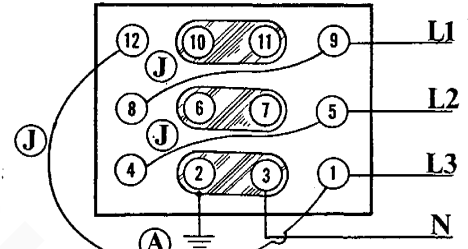

- L - L - 240 VAC 2Ø 60Hz
- L2, L3-N - 120 VAC 1Ø 60Hz
- L - L - 220 VAC 3Ø 50Hz
- L2, L3-N - 110 VAC 1Ø 50Hz

BE THREE PHASE (TWELVE WIRE)

A. SERIES DELTA-Note the repositioning of the ground lead from neutral to generator housing.

J. Jumper using #10 AWG wire.



GENERATOR AC VOLTAGE CONNECTIONS

AC VOLTAGE CONNECTIONS

NOTE The frame ground wire (white/green) must be properly positioned when changing the AC output configuration of the AC terminal block. For making connections to the AC terminal block, use terminal ends for 1/4 inch studs that will accept multi strand copper wire sized for the amperage rating from the hot lead connection. The frame ground wire is white or white with a green strip. It connects between the neutral stud and the generator frame.

Generator Frequency

1. Frequency is a direct result of engine/generator speed:
1800 rpm = 60 hertz; 1500 rpm = 50 hertz.
2. To change generator frequency, follow the steps below:
Configure the AC terminal block for the desired voltage frequency as shown. Ensure that the case ground wire is connected to the correct terminal block neutral ground stud.

NOTE: The white/green ground wire may be removed in those installations where the AC circuit has a separate neutral and ground circuit. This will prevent the unit from being a ground source in the vessel.

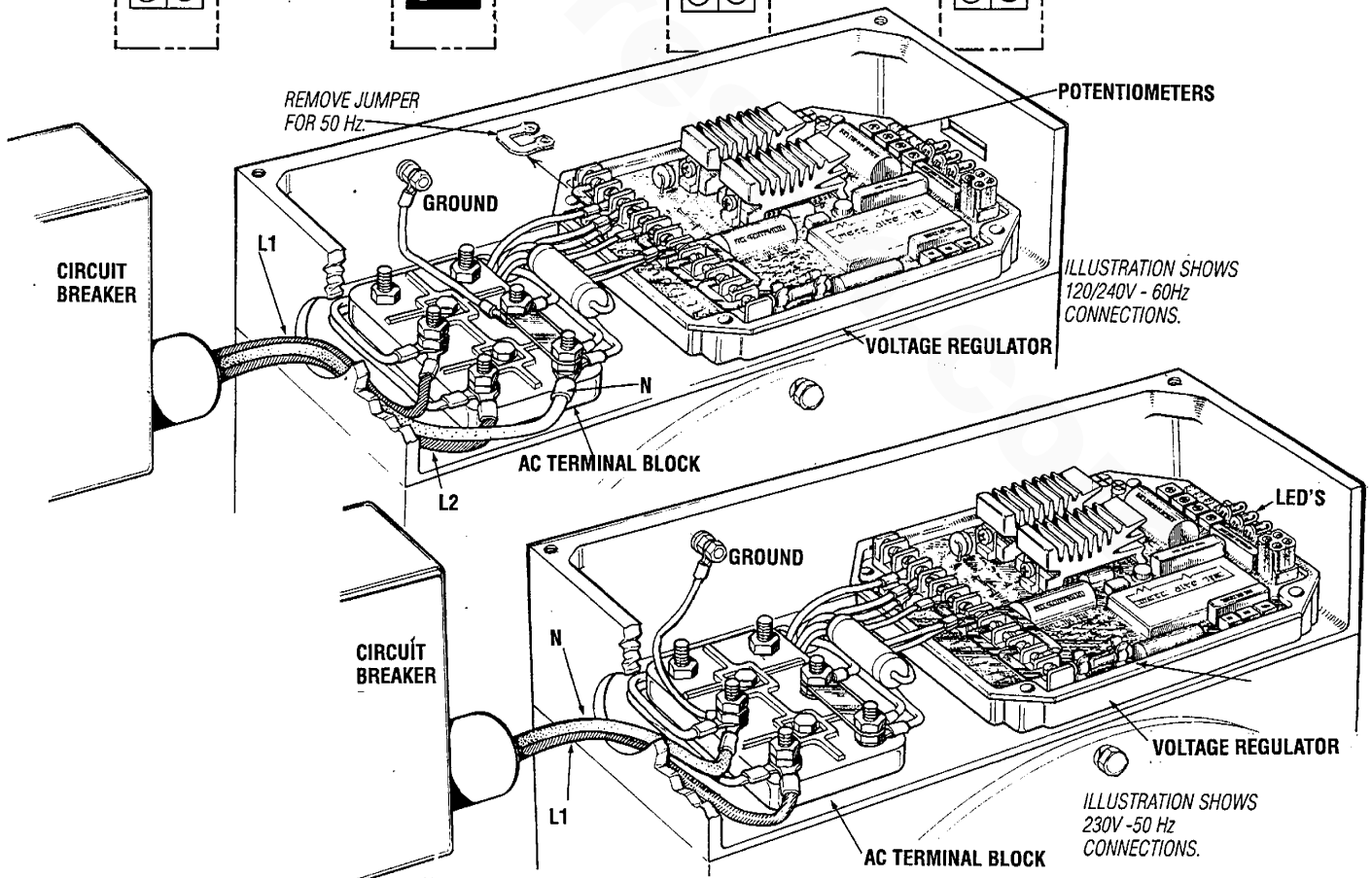
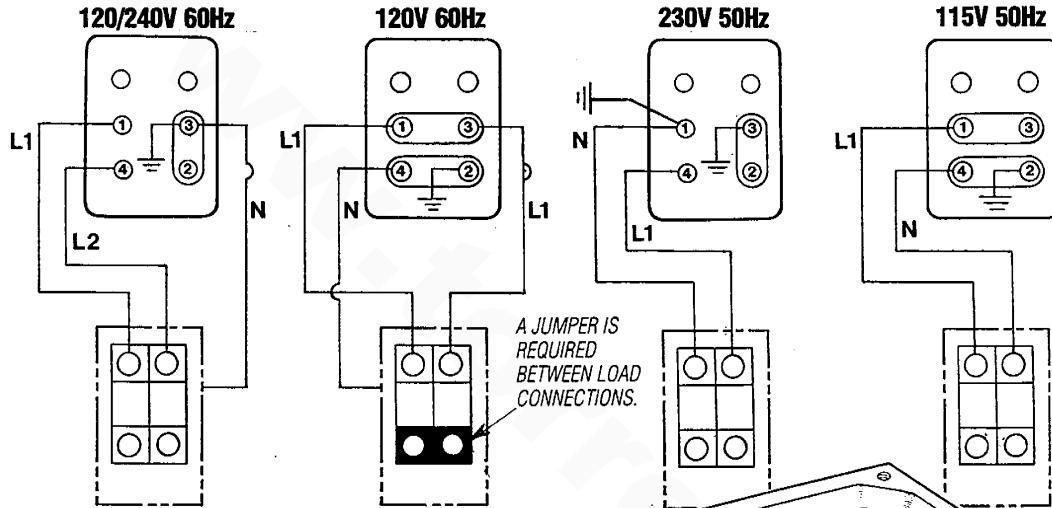

VOLTAGE REGULATOR ADJUSTMENTS

Description

The voltage regulator is an advanced design which ensures optimum AC alternator performance. It is equipped with complete protection circuitry to guard against operating conditions that could be detrimental to the AC alternator.

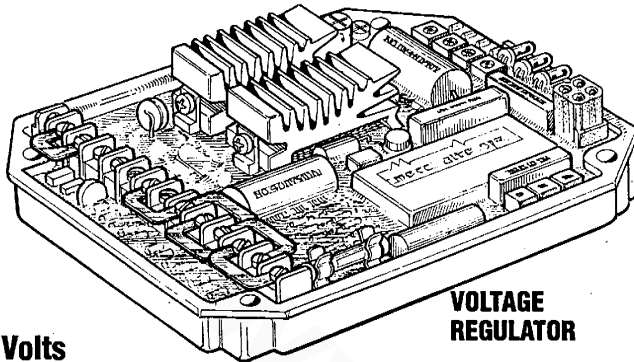

Volts

This potentiometer is used to adjust output voltage. At proper engine operating speed the output voltage should be held at $\pm 1\%$ from a no-load condition to a full rated generator output and from power factor 1.0 - 0.8 with engine drive speed variations up to -6%.

Prior to starting the engine, turn the VOLT and STAB trimmers (using a mini phillips screwdriver) fully in a counter clockwise (Minimum) direction until you feel them hit their stops.

Turn the AMP and HERTZ trimmers completely clockwise (Maximum) in the same manner.

With the alternator running at no-load, at normal speed, and with VOLT adjust at minimum, it is possible that output voltage will oscillate. Slowly rotate the VOLT adjust clockwise. The voltage output of the alternator will increase and stabilize. Increase the voltage to the desired value. In this situation, only the green LED will stay lit.

Stability

This potentiometer permits variation of the regulator's response to generator load changes so as to limit overcompensation and obtain a minimum recovery time to the normal voltage output.

In order to adjust the regulator stability the alternator must be running at no-load and the output must be monitored.

Turn the STAB adjust slowly clockwise until the voltage starts to fluctuate. At this point rotate the STAB adjust counterclockwise until the voltage is stable within 1 or 2 tenths of a volt.

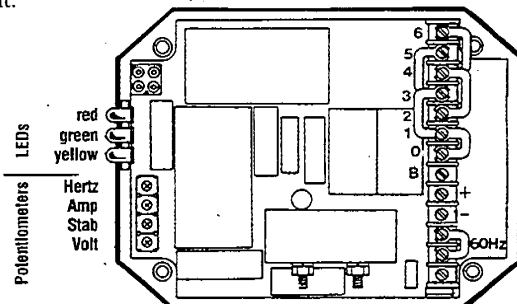

VOLTAGE REGULATOR DIAGRAM

Amp-Hertz

These two adjustments are used in conjunction with the two protection circuits in the voltage regulator that are indicated by the illumination of a colored LED lights.

1. Delayed overload protection (yellow LED).
2. Low speed protection (red LED).

Both systems have an intervention threshold which can be adjusted using the respective potentiometer. Each of the two circuits are able to cause an adequate reduction in excitor voltage to safeguard the excitor windings and prevent their overheating.

The overload protection system has a delay which permits temporary overloading of the generator during times such as motor start-up or other similar load surge demands. The regulator also has a third LED (green), that glows during generator operation to indicate correct operation of the regulator with the generator.

Setting the Overload Protection

In order to set the AMP overload protection, the alternator must be loaded to its full output rating.

1. Load the alternator to its rating, then decrease the speed of the engine by 10.10% (54 Hertz on 60 hertz units, 45 hertz on 50 hertz units).
2. Rotate the AMP adjustment counterclockwise until it hits its stop. Wait about 15-20 seconds after which the AC output of the alternator should drop and the yellow LED light should come on.
3. Slowly rotate the AMP adjustment clockwise until the output voltage increases to approximately 97% of the voltage output at the start of the adjustment. At this point the yellow LED light should come on.
4. Return to nominal speed, the yellow LED will turn off and the alternator voltage will rise to its normal value. Should this not happen, repeat the adjustment.

NOTE: When changing from 60 hertz to 50 hertz operation, remove the 60 hertz jumper bar from the regulator board.

Setting the Underspeed Protection

NOTE: If the unit is operating at 60 Hertz ensure that the jumper strap is in place on the regulator board between the two 60 Hertz terminals. In order to adjust the underspeed setting, the alternator should be running at no-load.

1. To adjust the underspeed (low frequency) protection circuit, lower the engine speed at 90% of its normal running speed (54 hertz on 60 hertz units, 45 hertz on 50 hertz units).
2. Rotate the Hertz adjustment counterclockwise slowly until the alternator's AC output voltage starts to decrease and at the same time the red "LED" light comes on.
3. Increase the engine speed to its normal speed (frequency). The red "LED" light will go out and the AC voltage output will return to normal.

With the above adjustments made, the regulator should function normally.



INTERNAL WIRING SCHEMATICS SINGLE PHASE

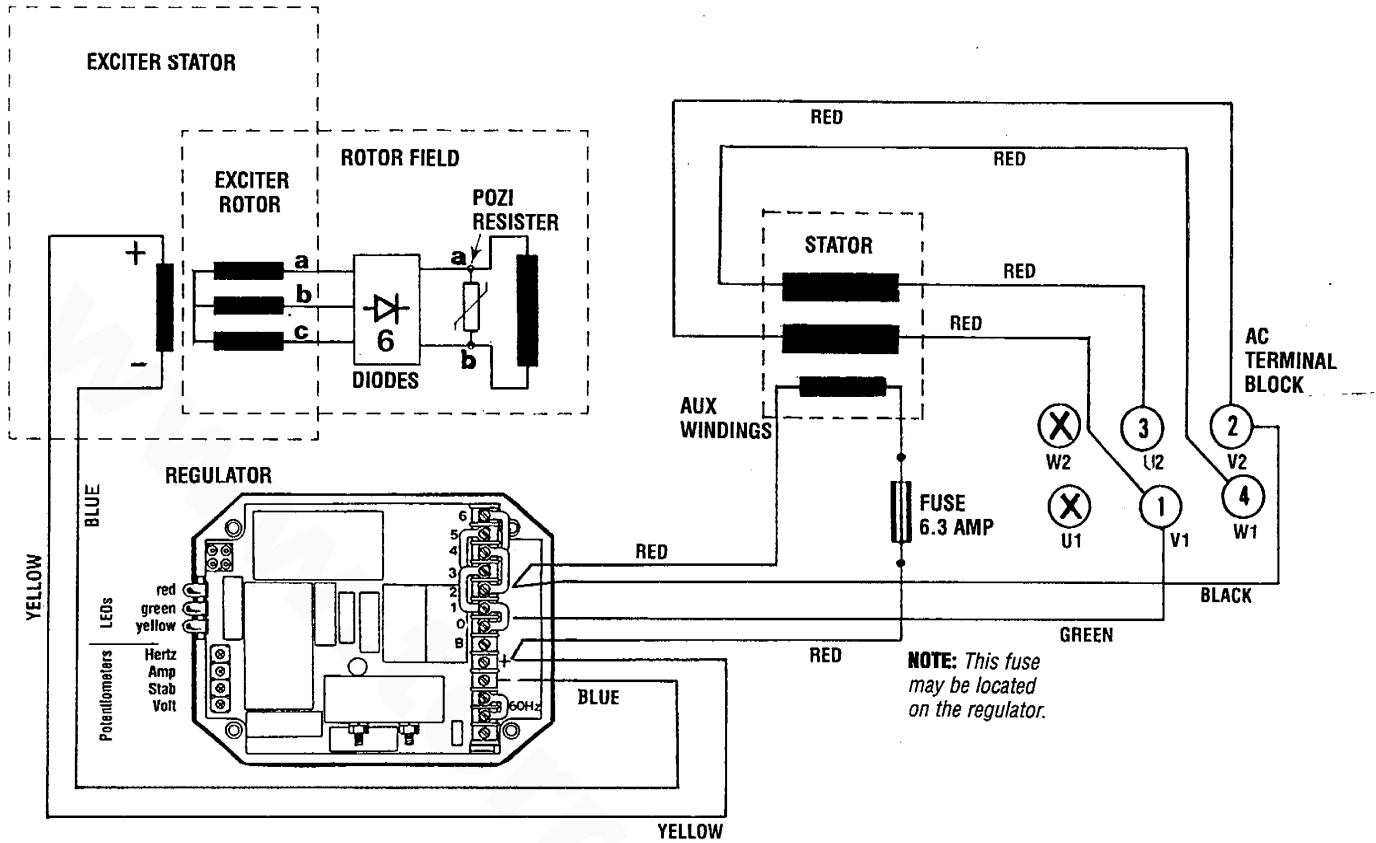

THREE PHASE 6 WIRE RECONNECTABLE

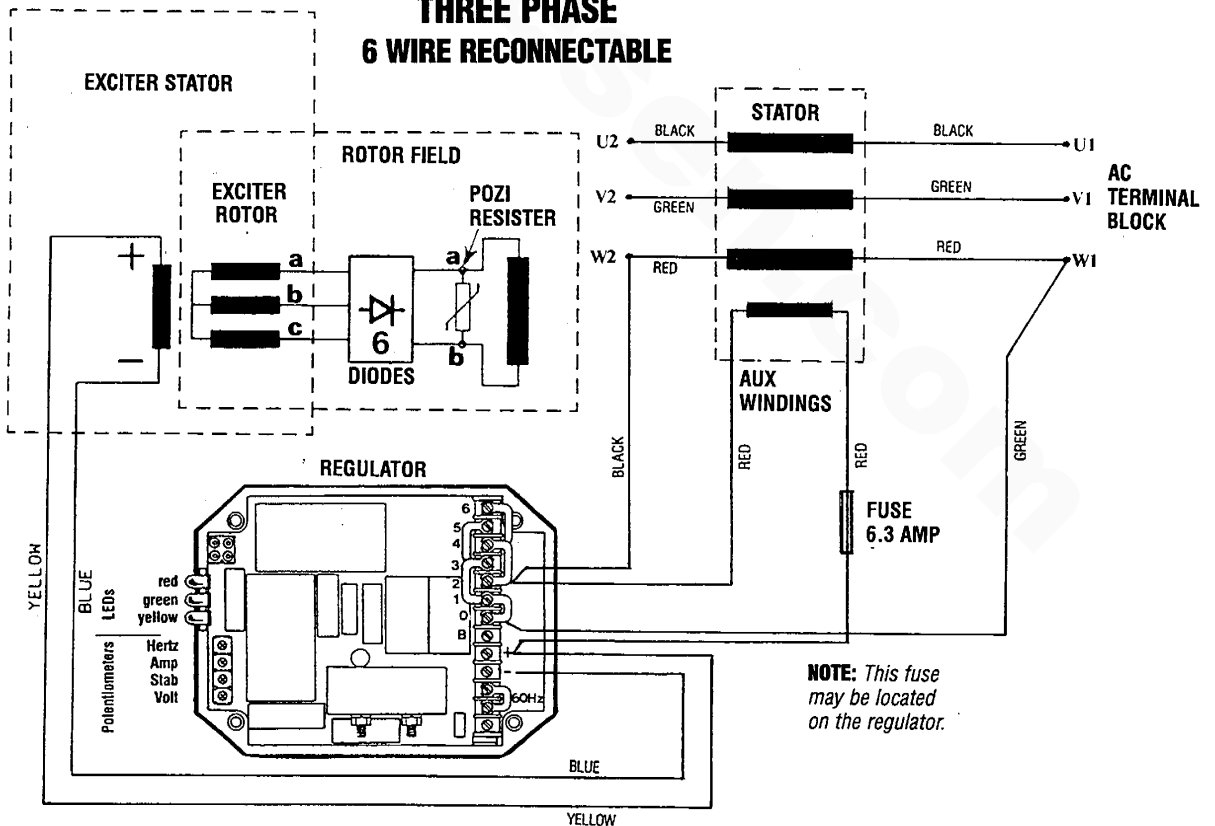

INTERNAL WIRING SCHEMATICS

3 PHASE TWELVE WIRE RECONNECTABLE

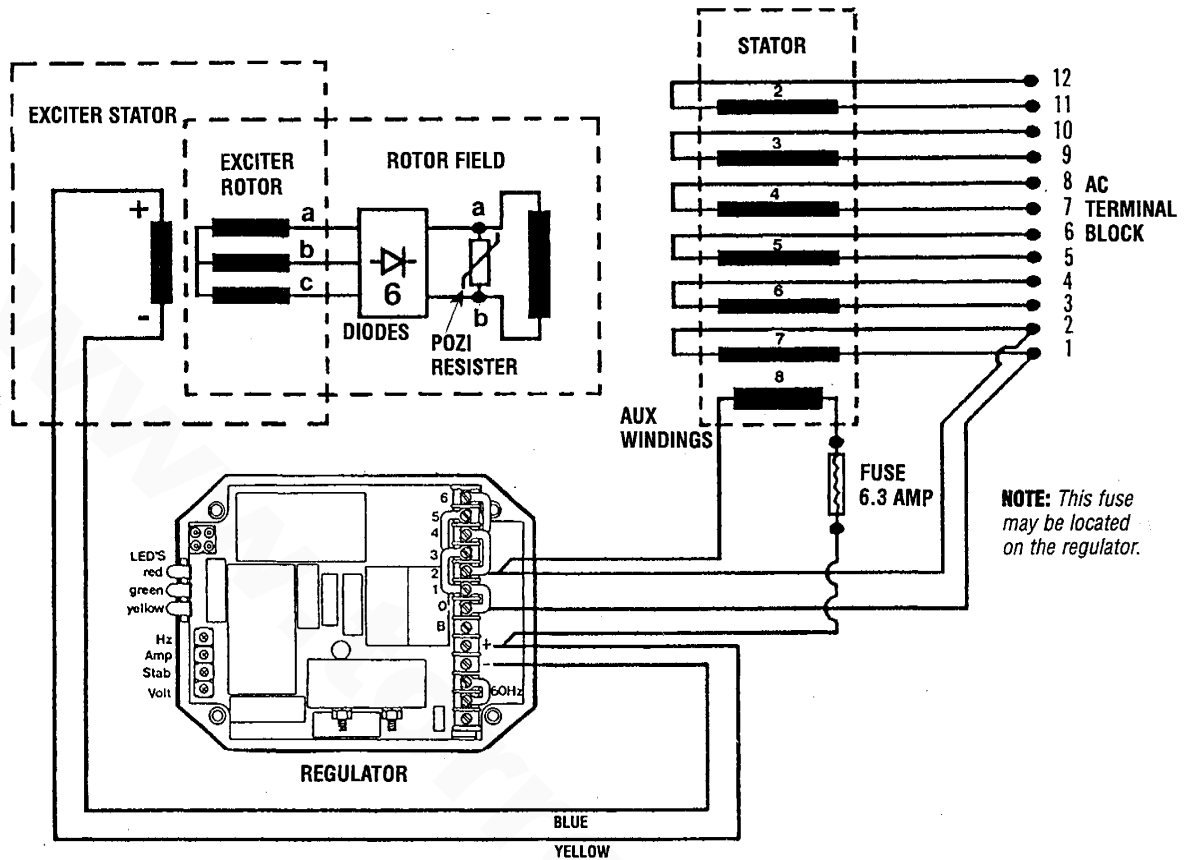

BE GENERATOR WINDING RESISTANCE VALUES (IN OHMS)

	SINGLE PHASE	20 & 25 BE	32 BE
EXCITER STATOR		18.06	18.20
EXCITER ROTOR	a - b	0.68	0.72
	b - c	0.68	0.72
ROTATING FIELD		1.75	2.01
MAIN STATOR	1 - 2	0.05	0.05
	3 - 4	0.05	0.05
AUXILLARY WINDING		1.19	0.98
THREE PHASE			
		20, 25, & 32 BE	
EXCITER STATOR		18.20	
EXCITER ROTOR	a - b	0.7	
	b - c	0.7	
ROTATING FIELD		2.01	
MAIN STATOR		0.06 (each winding)	
AUXILLARY WINDING		0.98	



BE TROUBLESHOOTING

NOTE: AC GENERATOR TROUBLESHOOTING MUST BE PERFORMED WITH ENGINE OPERATING AT 60 HERTZ.

PROBLEM	PROBABLE CAUSE	
No AC voltage output at no load.	<ol style="list-style-type: none"> 1. Short or open in the main stator winding. 2. Shorted pozi-resistor on exciter rotor. 3. Four or more shorted or open diodes on exciter rotor. 	<ol style="list-style-type: none"> 4. Short or open in exciter stator winding. 5. Short or open in rotating field winding.
Residual voltage produced at no load 15 - 20 volts AC.	<ol style="list-style-type: none"> 1. Blown 6 AMP base fuse auxiliary circuit feed to AVR. 2. Faulty voltage regulator 	<ol style="list-style-type: none"> 3. Shorted or open main stator auxiliary winding.
Low AC voltage output at no load 60 - 100 VAC.	<ol style="list-style-type: none"> 1. Open or shorted diodes in exciter rotor 1 to 3 diodes. 2. Open or shorted exciter rotor winding 	<ol style="list-style-type: none"> 3. Faulty voltage regulator.
High AC output voltage 150 VAC or higher.	<ol style="list-style-type: none"> 1. Faulty voltage regulator. 	
Unstable voltage output.	<ol style="list-style-type: none"> 1. STB pod on regulator needs adjustment. 	<ol style="list-style-type: none"> 2. Faulty voltage regulator.
AC voltage drop under load 60 - 100 volts AC.	<ol style="list-style-type: none"> 1. Diode(s) on exciter rotor breaking down when load is applied (inductive) 1-3 diodes. 	

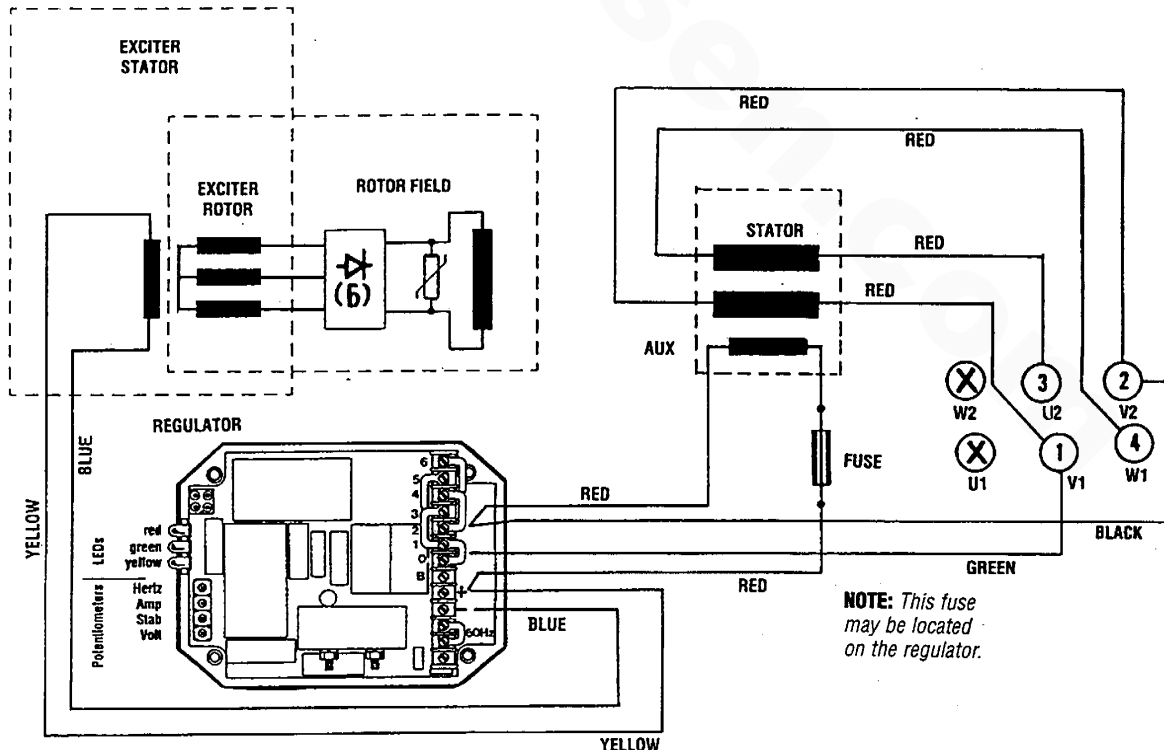

ELECTRONIC GOVERNOR

Electronic Governor System

The system is composed of three basic components:

1. **Controller.** Mounted in the instrument panel.
2. **Sensor.** Installed on the bellhousing over the flywheel ring gear.
3. **Actuator.** Mounted at the front of the engine and attached with linkage to the throttle arm of the injection pump.

Controller Adjustment

1. **Speed.** This adjustment is used to raise or lower the engine's speed to the desired hertz.
2. **Gain.** This adjustment affects the reaction time of the actuator to the generator/engine load changes.

NOTE: A high gain adjustment can induce an oscillating of the actuator producing a hunting mode. In such cases, lessen the gain adjustment.

Calibration

1. With no power to the governor, adjust the GAIN to 9:00 o'clock.
2. Start the engine and adjust the speed by turning the speed pot clockwise to desired speed.

NOTE: Controllers are factory adjusted to minimum rpm. However, for safety, one should be capable of disabling the engine if an overspeed should exist.

3. At no-load, turn the GAIN potentiometer clockwise until the engine begins to hunt. if the engine does not hunt, physically upset the governor linkage.
4. Turn the GAIN potentiometer counterclockwise until stable.

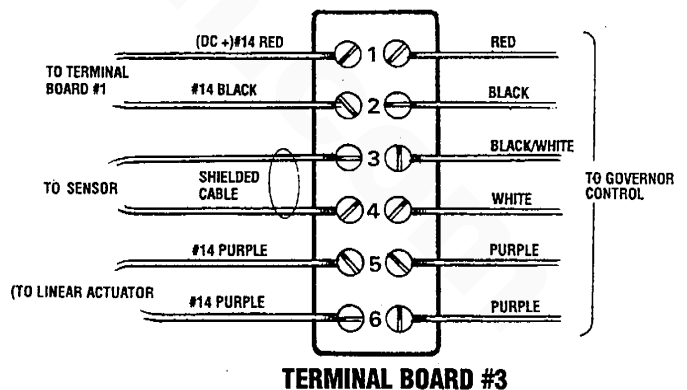
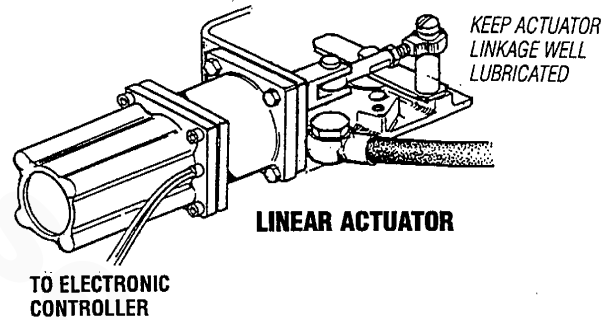
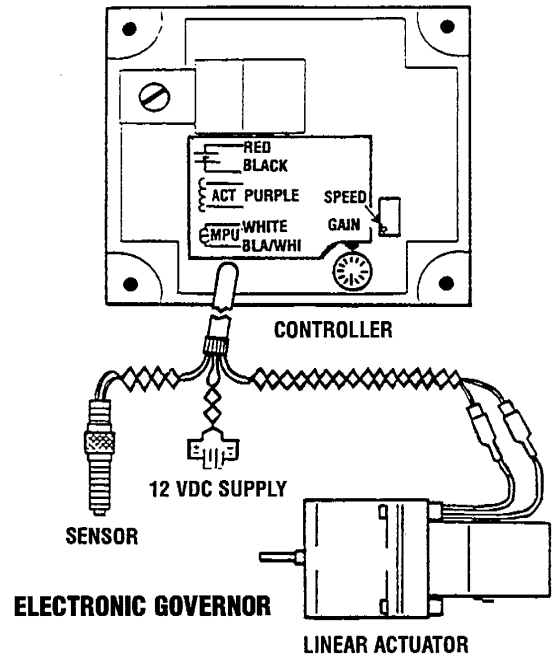
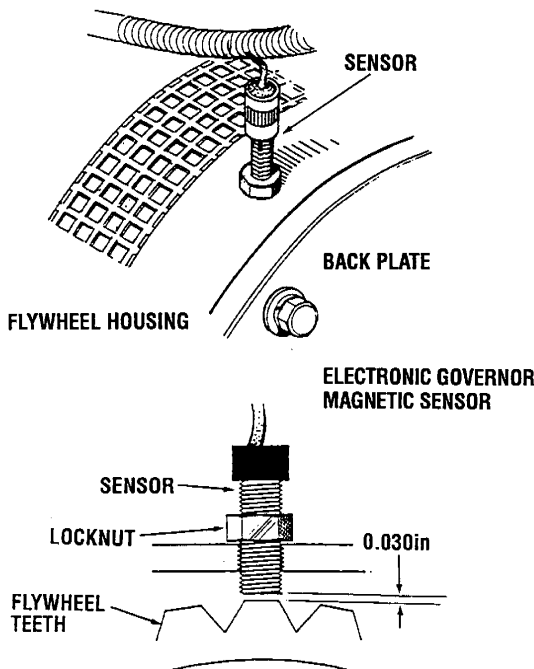

TROUBLESHOOTING THE ELECTRONIC GOVERNOR

Problem	Probable Cause	Verification/Remedy
System appears dead (Engine runs at idle.)	<ol style="list-style-type: none"> 1. Low battery voltage at controller. 2. Stuck linkage. 3. No signal or weak signal from sensor. (Measure AC voltage from sensor while engine is running at idle. Voltage should be 2.5 volts or greater. 4. Check Actuator – depress PREHEAT and check for battery voltage between negative black lead at terminal block. <ol style="list-style-type: none"> a. Purple lead to black. b. Second purple to black. 5. Perform the following check between terminals at the actuator and the negative DC lead at the controller terminal block. (Preheat depressed). <ol style="list-style-type: none"> a. Low voltage (1.20-2.0 VDC) at either actuator connection. b. Battery voltage at both actuator connections. c. Battery voltage at one actuator lead but not the other. 	<ol style="list-style-type: none"> 1. Check wiring for cause. Check battery state of charge. 2. Lubricate, free up linkage between controller and throttle arm. 3. Check for improperly installed or damaged sensor in flywheel housing. Replace or adjust. 4. Replace controller if battery voltage is not present at both leads. <ol style="list-style-type: none"> a. Broken actuator lead. b. Broken actuator lead. c. Replace the actuator.
Actuator fully extends when PREHEAT is depressed and stays extended.	<ol style="list-style-type: none"> 1. Check controller. Lift one of the purple actuator leads from the terminal block. Depress PREHEAT. <ol style="list-style-type: none"> a. Actuator fully extends. b. Actuator does not fully extend and connections. <p>NOTE: Release PREHEAT and reconnect the purple lead.</p>	<ol style="list-style-type: none"> a. Short in lead to actuator. b. Replace controller.
Actuator hunts (oscillates) and engine running.	<ol style="list-style-type: none"> 1. Linkage between actuator and throttle binding. 2. Improper adjustment of GAIN on controller. 3. Inadequate DC power supply to controller, complete the following tests: Connect a DC voltmeter across the plus and negative leads at the controller terminal block. Lift both purple leads from the terminal block. Connect one purple lead to the C plus terminal and the other to the DC negative. Momentarily depress PREHEAT. The actuator should fully extend. <p>3a. Sensor positioned marginally too far away from flywheel teeth giving erratic signal voltage to controller.</p>	<ol style="list-style-type: none"> 1. Lubricate/free-up. 2. Lessen GAIN adjustment (Recalibrate the Controller). 3. If actuator does not fully extend, check the actuator leads. If the voltage is less than specified, check for loose or poor connections, low battery voltage, voltage drop in DC circuit due to remote panel installation and small wire sizes making connections. DC voltage registering on the meter should be: 12 VDC System – 9.6 VDC or higher 24 VDC System – 19.2 VDC or higher <p>NOTE: Reconnect actuator leads properly after making this test.</p> <p>3a. Check the position of the sensor.</p>



SHORE POWER TRANSFER SWITCH

SHORE POWER CONNECTIONS (60 HERTZ)

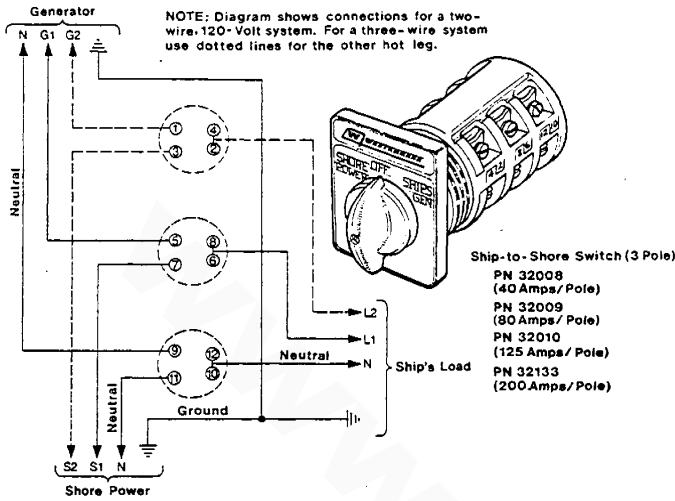

If the installer connects shore power to the vessel's AC circuit, this must be done by means of the Shore Power Transfer Switch. Set the transfer switch shown in the diagrams to the OFF position. This switch prevents simultaneous connection of shore power to generator output.

CAUTION: Damage to the generator can result if utility shore power and generator output are connected at the same time. This type of generator damage is not covered under the warranty; it is the installer's responsibility to make sure all AC connections are correct.

120 VOLT/60 HZ THREE WIRE CONFIGURATION

Notice the repositioning of the white wire ground load on the terminal block to the generator case.

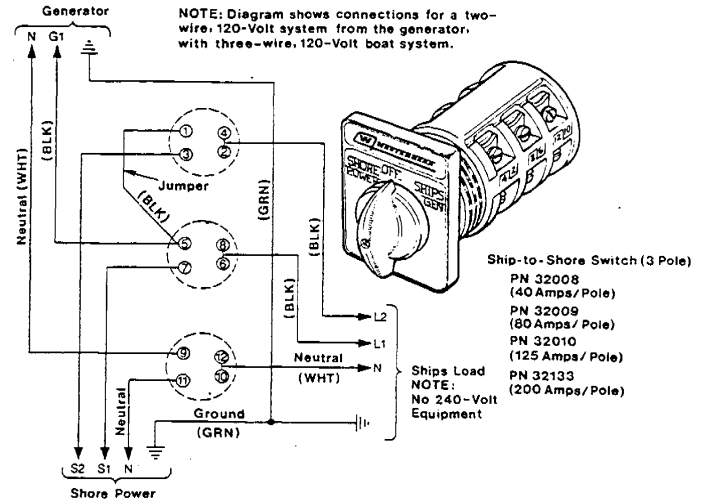

Switching Shore Power to Generator Power

CAUTION: Heavy motor loads should be shut off before switching shore power to generator power or vice-versa because voltage surges induced by switching with heavy AC loads on the vessel being operated may cause damage to the exciter circuit components in the generator.



BED GENERATOR

WIRING SCHEMATIC #039422

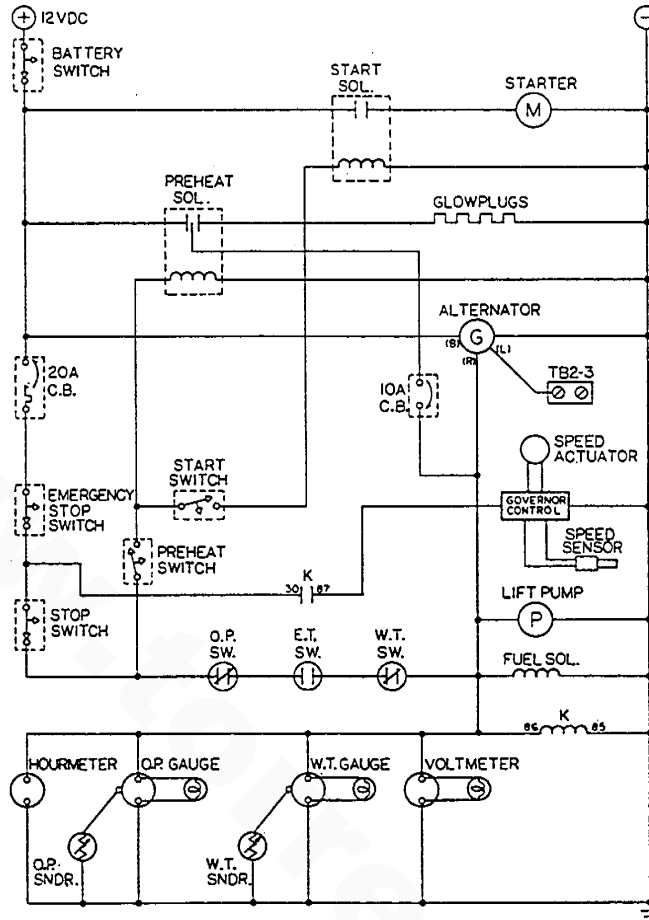

REMOTE START/STOP PANEL

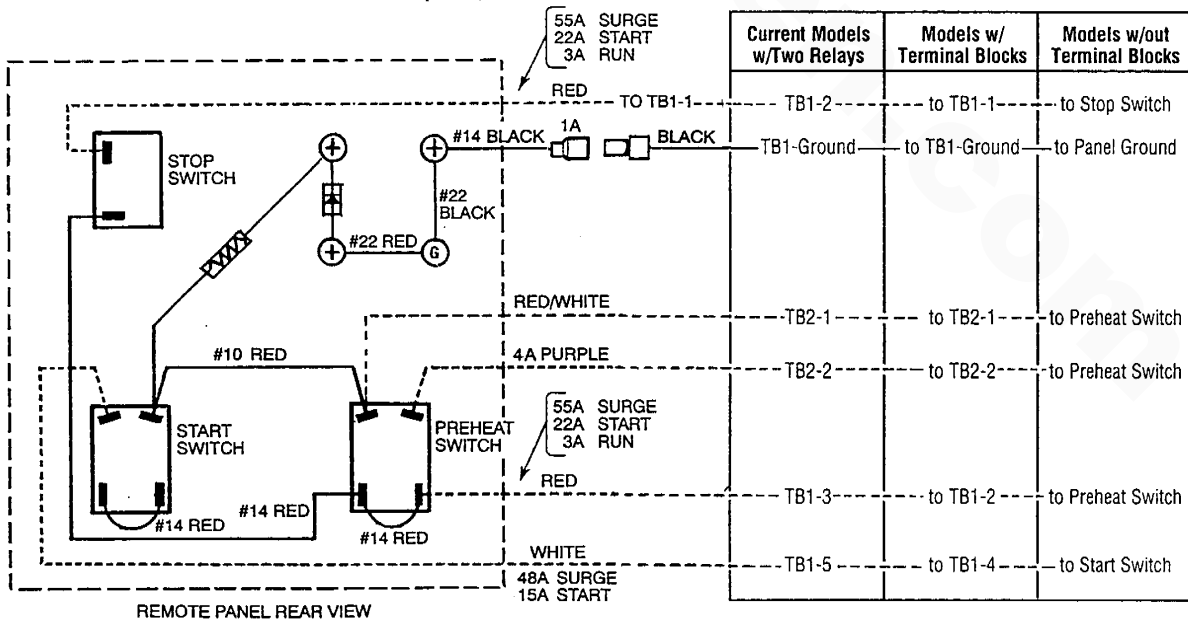

BED GENERATOR WIRING DIAGRAM #039422

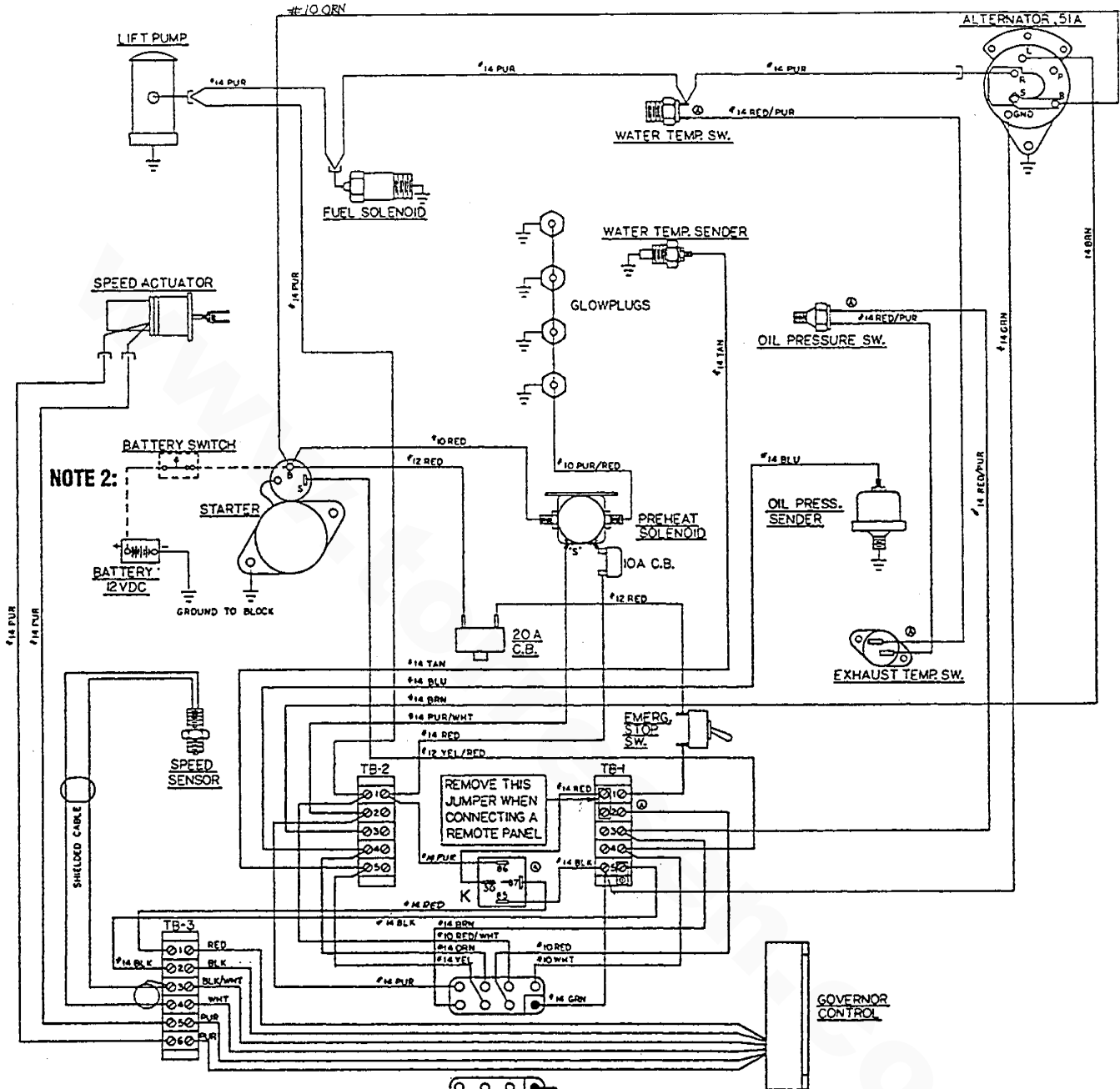

NOTE 2:

An on-off switch should be installed in this circuit to disconnect the starter from the battery in an emergency and when leaving the boat. Twelve volt diesel engine starters typically draw 200 to 300 amps when cranking. A switch with a continuous rating of 175 amps at 12 VDC will normally serve this function, but a switch must never be used to "make" the starter circuit.

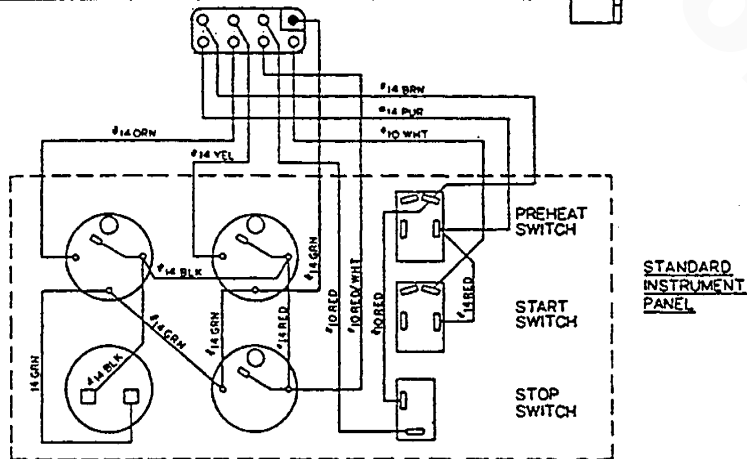

BED GENERATOR

WIRING SCHEMATIC #039422 (WITH DUAL RELAYS)

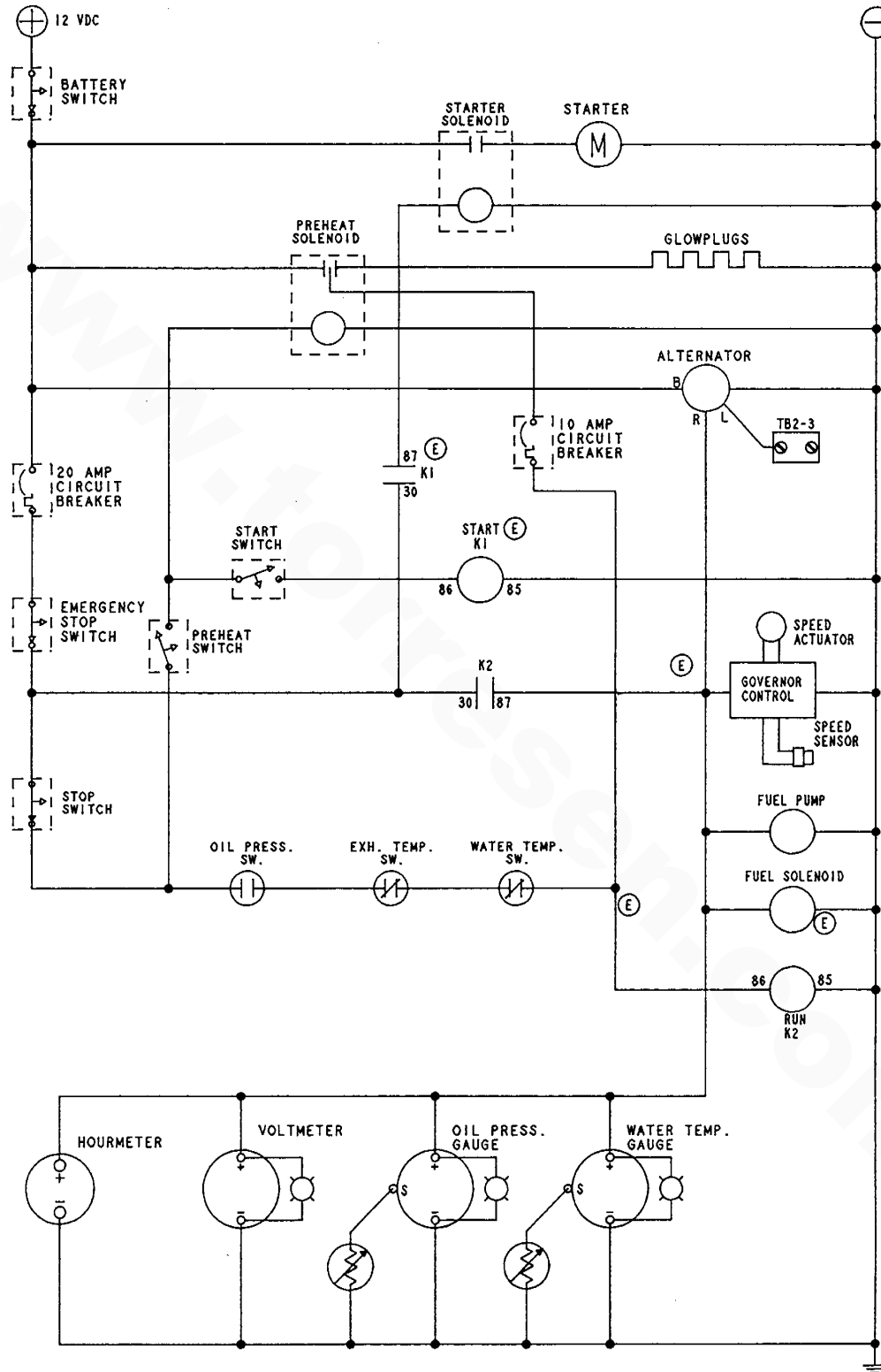

BED GENERATOR

WIRING DIAGRAM #039422 (WITH DUAL RELAYS)

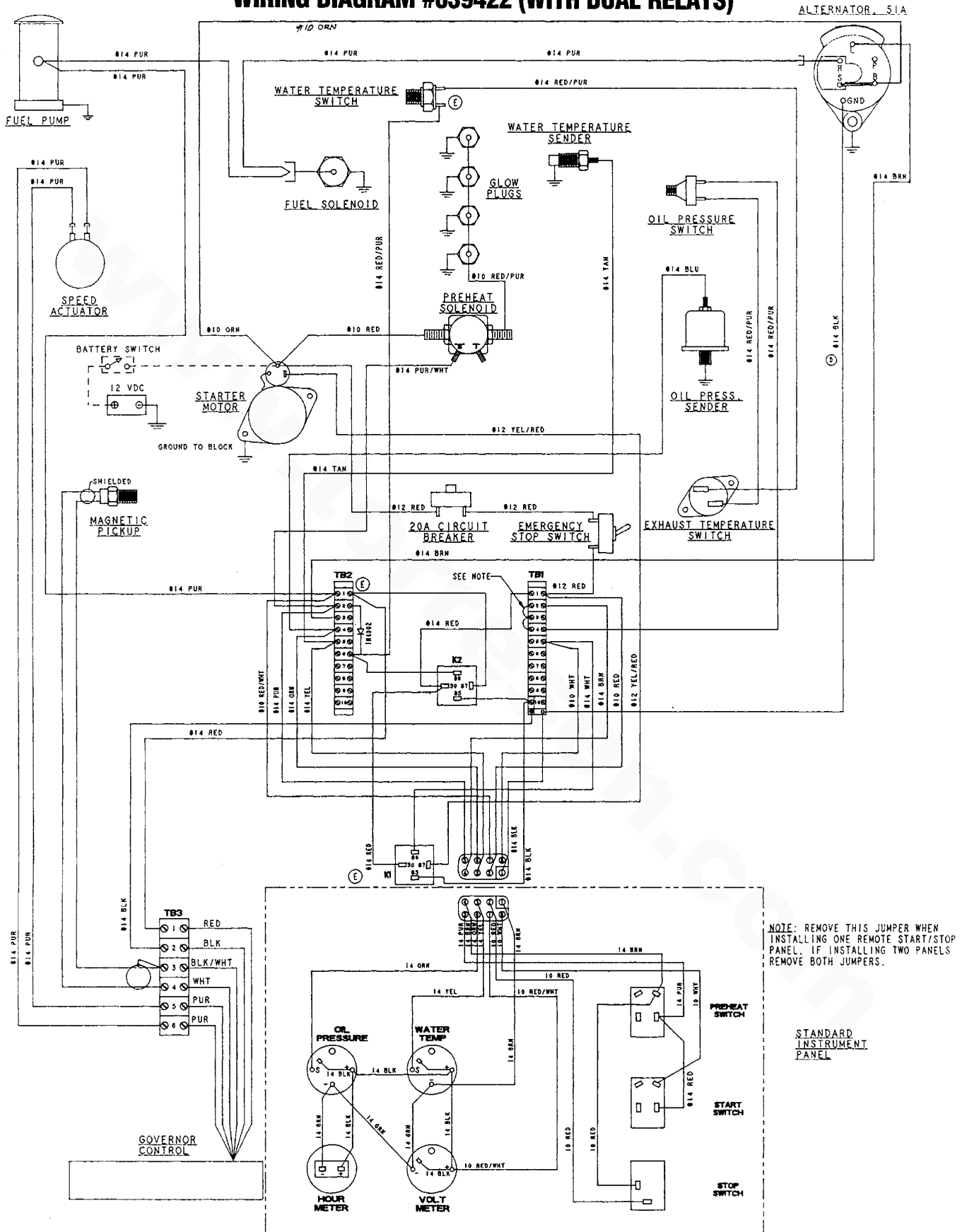

SPECIFICATIONS

WESTERBEKE 25 KW BED GENERATOR

ENGINE SPECIFICATIONS	
Engine Type	Diesel, four-cylinder, four-cycle, fresh water-cooled, vertical in-line overhead valve mechanism.
Aspiration	Naturally aspirated
Governor	Electronic Governing.
Combustion Chamber	Swirl type
Bore & Stroke	3.74 x 4.13 inches (95 x 105 mm)
Piston Displacement	182 cubic inches (2.98 liters)
Firing Order	1 - 3 - 4 - 2
Direction of Rotation	Clockwise, when viewed from the front
Compression Ratio	21 : 1
Dimensions	Height: 28.6 inches (726.5 mm) Width: 23.3 inches (591.8 mm) Length: 44.9 inches (1149.4 mm)
Weight	678 lbs (307 kgs)
Inclination	Continuous 15° Temporary 25° (not to exceed 20 min.)
Generator Power Take Off	40 Horsepower (Maximum)
TUNE-UP SPECIFICATIONS	
Compression Pressure (Limit of difference between cylinders)	427 psi (30 kg/cm ²) at 200 rpm (47.2 psi {3.0 kg/cm ² })
Valve Timing	Intake Opens 17° BTDC Intake Closes 47° ABDC Exhaust Opens 51° BBDC Exhaust Closes 13° ATDC
Valve Seat Angle	Intake 45° Exhaust 30°
Valve Clearance (engine warm)	Intake 0.012 inches (0.3 mm) Exhaust 0.012 inches (0.3 mm)
Injector Pressure	1920 + 71 - 0 psi (135 + 5 - 0 kg/cm ²)
Engine Timing	Static timed - drop valve method 0.205 ± .005 inches BTDC
EXHAUST EMISSIONS SYSTEMS	
Emission Control Systems	Indirect Fuel Injection

FUEL SYSTEM	
General	Open flow, self priming - 1 bleed point.
Fuel	No. 2 diesel oil (cetane rating of 45 or higher)
Fuel Injection Pump	ZEXEL Model VE Distributor.
Fuel Injection Timing	0° TDC (Top Dead Center)
Nozzle	Throttle type
Fuel Filter (on engine)	Spin-on type, full flow
Air cleaner	Metal screen type - cleanable
Air Flow (engine combustion)	94.6 cfm (2.7 cmm)
COOLING SYSTEM	
General	Fresh water-cooled block, thermostatically-controlled with heat exchanger.
Operating Temperature	170 - 190° F (77 - 88° C)
Fresh Water Pump	Centrifugal type, metal impeller, belt-driven
Raw Water Pump	Positive displacement, rubber impeller, belt-driven.
Raw Water Flow, at 3600 rpm	15.0 gpm (56.7 lpm) (measured before discharging into exhaust elbow).
System Capacity (coolant)	13.0 qts (12.3 liters)
LUBRICATION SYSTEM	
General	Pressure fed system
Oil Filter	Full flow, paper element, spin-on type
Sump Capacity (not including filter)	6.5 U.S. qts (6.15liters) plus filter/cooler assembly
Operating Oil Pressure (engine hot)	50 - 60 psi (3.5 - 4.2 kg/cm ²)
Oil Grade	API Specification CF or CG-4, SAE 30, 10W-30, 15W-40
ELECTRICAL SYSTEM	
Starting Battery	12-Volt, (-) negative ground
Battery Capacity	300 - 600 Cold Cranking Amps (CCA)
Starter	12-Volt, reduction
Starting Aid	Glow plugs, sheathed type



SPECIFICATIONS WESTERBEKE 25 KW BED GENERATOR

ELECTRICAL SYSTEM	
Starting Battery	12-Volt, (-) negative ground
Battery Capacity	400 - 600 Cold Cranking Amps (CCA)
DC Charging Alternator	51 Amp rated, belt-driven
Starter	12-Volt, Reduction Gear
Starting Aid	Glow plugs, sheathed type
DC No-Load Current	± 2% of rated Amps
DC Cranking Current	250 - 300 Amps (engine cold)
AC GENERATOR (SINGLE PHASE)	
General - Single Phase	Brushless, four-pole, revolving field Sealed lubricated single bearing design. Reconnectable single phase for 120/240 volts with solid state voltage regulator.
Voltage - Single Phase	120 or 120/240 Volts - 60 Hertz 230 Volts - 50 Hertz
Voltage regulation:	± 2% no load to full load.
Frequency regulation:	.3 Hertz no load to full load.
Rating (Volts AC)	20 KW - 60 Hertz (1800 rpm) 120 Volts 208 Amps 120/240 Volts 208.109 Amps 20 KW - 50 Hertz (1500 rpm) 230 Volts 87 Amps

AC GENERATOR (THREE PHASE)		
General - 3 Phase	Brushless six pole, revolving field. Sealed lubricated single bearing design. 12 Lead reconnectable for low voltage WYE and for Delta. Solid State voltage regulator with protection circuitry.	
Voltage - 3 Phase (60 Hertz)	Low voltage WYE	208 volts
	High voltage WYE	480 volts
	DELTA	240 volts
Voltage - 3 Phase (50 Hertz)	High voltage WYE	380 volts
	DELTA	240 volts
Amperage - 3 Phase (60 Hertz)	Low voltage WYE	86.7 Amps
	High voltage WYE	37.6 Amps
	DELTA	75.2 Amps
Amperage - 3 Phase (50 Hertz)	High voltage WYE	38.0 Amps
	DELTA	65.6 Amps
GENERATOR COOLING		
Air Requirements (60 Hertz at 1800 RPM)	1.0 Power Factor 425 cfm (12.74 cmm)	
Note: Increase air supply 15% for 50 Hertz operation 1500 rpm		
Engine Combustion Air Requirements (60 Hertz at 1800 RPM)	94.6 cfm (2.7 cmm)	



SPECIAL TOOLS - GENERATOR

FIELD FABRICATED TOOLS

These drawings provide a means by which simple tools can be made to assist in the removal of the generator end from the engine and in the replacement of the generator end on the engine. A local machine shop should be able to fabricate these tools at a modest price, but first check with your local WESTERBEKE dealer to see if these tools are on hand for loan.

Housing Puller Tool

This tool allows the bearing in the generator housing to be gently pushed straight off the housing without any twisting. If a nut of the same specifications as that of the tapped hole in the pilot tool were to be welded on the end of the eye bolt, this tool would be able to pull the bearing back into place without any twisting. Please refer to these drawings before the generator end is removed.

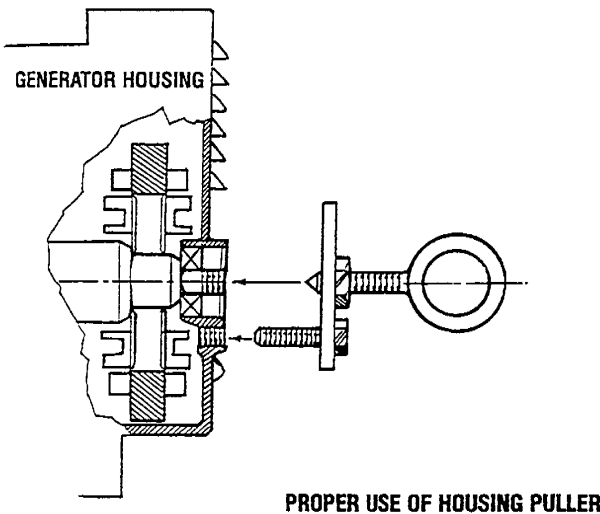
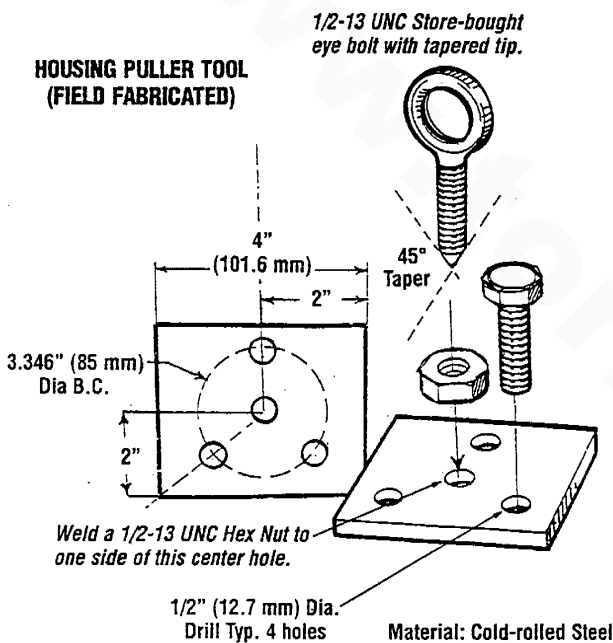

Lifting Eye Tool

This tool allows a mechanic to safely remove the generator end from the engine by attaching this Generator End Lifting Eye to the four screw holes located under the control panel. To use this Lifting Eye, remove the generator's control panel and screw the Lifting Eye to the generator end.

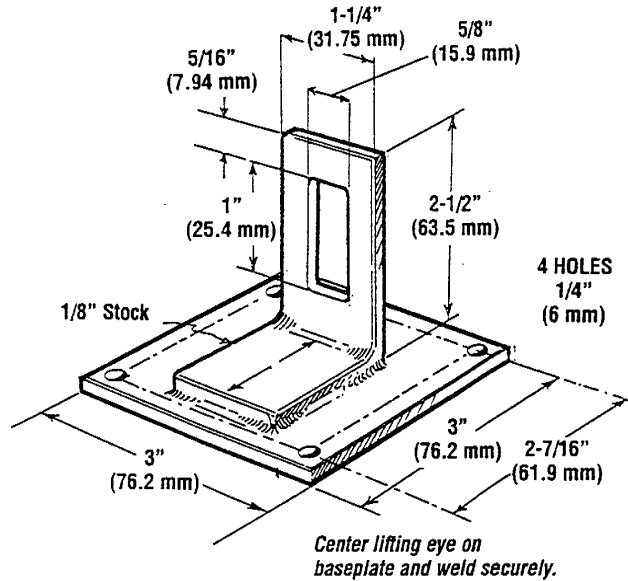

Disk Alignment Tool

This tool allows a mechanic to safely remove and install the generator drive disks by aligning the disks with the Drive Plate Guide Pin. The Pin screws into the flywheel and acts as a guide. Also the pin helps to support some of the rotor and the drive plate's weight while removing or replacing these parts.

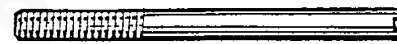

Material: One M8 bolt with the hex head machined off and a screwdriver slot cut in the machined end.

Pilot Tool

The tool below helps keep the rotor from damaging the windings in the generator housing to be removed straight off the engine or to be placed straight on the engine. Refer to the removal and replacement diagram at the bottom of the page.

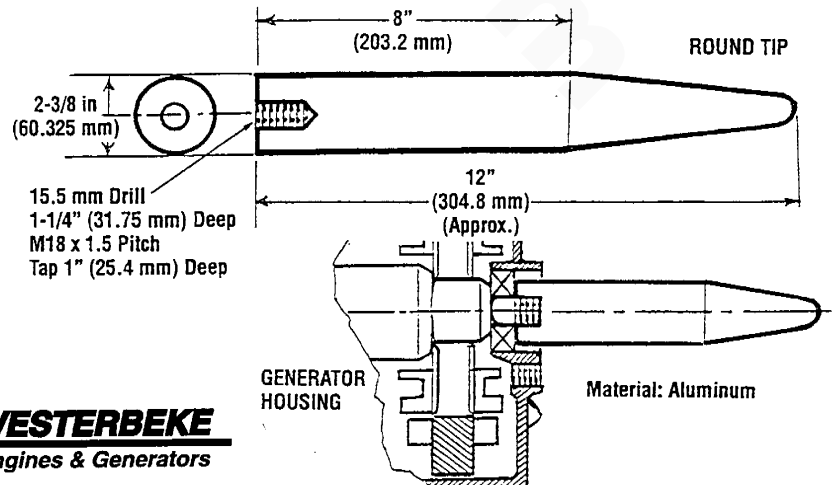

METRIC CONVERSIONS

INCHES TO MILLIMETERS				MILLIMETERS TO INCHES			
Inches	mm	Inches	mm	mm	Inches	mm	Inches
1	25.40	15	381.00	1	0.0394	15	0.5906
2	50.80	20	508.00	2	0.0787	20	0.7874
3	76.20	25	635.00	3	0.1181	25	0.9843
4	101.60	30	762.00	4	0.1575	30	1.1811
5	127.00	35	889.00	5	0.1969	35	1.3780
10	254.00	40	1016.00	10	0.3937	40	1.5748

10 MILLIMETERS = 1 CENTIMETER, 100 CENTIMETERS = 1 METER = 39.37 INCHES (3.3 FEET)

INCHES TO METERS				METERS TO INCHES			
Inches	Meters	Inches	Meters	Meters	Inches	Meters	Inches
1	0.0254	7	0.1778	0.1	3.937	0.7	27.559
2	0.0508	8	0.2032	0.2	7.874	0.8	31.496
3	0.0762	9	0.2286	0.3	11.811	0.9	35.433
4	0.1016	10	0.2540	0.4	15.748	1.0	39.370
5	0.1270	11	0.2794	0.5	19.685	1.1	43.307
6	0.1524	12	0.3048	0.6	23.622	1.2	47.244

TO CONVERT METERS TO CENTIMETERS, MOVE DECIMAL POINT TWO PLACES TO THE RIGHT

YARDS TO METERS				METERS TO YARDS			
Yards	Meters	Yards	Meters	Meters	Yards	Meters	Yards
1	0.91440	6	5.48640	1	1.09361	6	6.56168
2	1.82880	7	6.40080	2	2.18723	7	7.65529
3	2.74320	8	7.31520	3	3.28084	8	8.74891
4	3.65760	9	8.22960	4	4.37445	9	9.84252
5	4.57200	10	9.14400	5	5.46807	10	10.93614

MOVE DECIMAL POINT FOR HIGHER VALUES — e.g. 6,000 METERS = 6,561.68 YARDS

POUNDS TO KILOGRAMS				KILOGRAMS TO POUNDS			
lb	kg	lb	kg	kg	lb	kg	lb
1	0.454	6	2.722	1	2.205	6	13.228
2	0.907	7	3.175	2	4.409	7	15.432
3	1.361	8	3.629	3	6.614	8	17.637
4	1.814	9	4.082	4	8.818	9	19.842
5	2.268	10	4.536	5	11.023	10	22.046

GALLONS TO LITERS				LITERS TO GALLONS			
Gallons	Liters	Gallons	Liters	Liters	Gallons	Liters	Gallons
1	3.79	10	37.86	1	0.26	60	15.66
2	7.57	20	75.71	2	0.53	90	23.77
3	11.36	30	113.57	5	1.32	120	31.32
4	15.14	40	151.42	10	2.64	150	39.62
5	18.93	50	189.28	20	5.28	180	47.54

PINTS TO LITERS				LITERS TO PINTS			
Pints	Liters	Pints	Liters	Liters	Pints	Liters	Pints
1	0.47	6	2.84	1	2.11	6	12.68
2	0.95	7	3.31	2	4.23	7	14.79
3	1.42	8	3.79	3	6.34	8	16.91
4	1.89	9	4.26	4	8.45	9	19.02
5	2.37	10	4.73	5	10.57	10	21.13

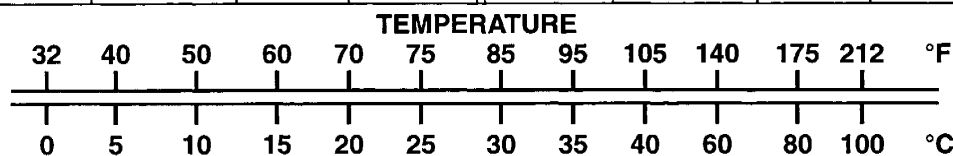

INDEX

AC Voltage Connections	53, 63	Raw Water Pump	44
Alternator Testing	50	Rear Oil Seal	23
Camshaft	21	Reassembly	23
Compression-Engine	39	Rocker Arm	17
Connecting Rod	19	Specifications	54
Control Panel Troubleshooting	61	Standards and Limits	55
Coolant Circulating pump	41	Starter Motor	45
Crankshaft	20	Stop Solenoid	40
Cylinder Block	17	Tappets	22
Cylinder Head Bolt Pattern	27, 35	Thermostat	28
Cylinder Liner	17	Timing Gears Cover	23
Electronic Governor	69	Timing Gears	12, 22
Electronic Governor Troubleshooting	70	Testing for Overhaul	7
Engine		Torque Specifications	57
Adjustments	39, 40	Troubleshooting	3
Assembly	24	Valve Clearance	28, 39
Camshaft	21	Valve Guide	15
Checking - gears	22	Valve Seat	16
Coolant Pump	41	Valve Spring	14
Compression	39	Valve Spring Removal	11
Connecting Rod	19	Wiring Diagram	52
Crankshaft	20	Wiring Schematic	53
Cylinder Block	17	Exhaust Manifold	31
Cylinder Head Bolt Pattern	27	Frequency - Adjustment	50, 53
Cylinder Liner	17	Fuel Injection Pump	32, 33
Disassembly	8	Fuel Injectors	34, 35
Exhaust Manifold	31	Fuel Lift Pump	33
Fuel Injection Pump	32	Fuel System Troubleshooting	36
Fuel Injectors	34	Generator	
Fuel Lift Pump	33	AC Voltage Connections	63, 64
Glow Plugs - Testing	38	BE Single and Three Phase	62
Heat Exchanger	31	Circuit Breaker	62
Injection Pump	9, 10, 32	Control Panel Switches	60
Injection Timing	32	Control Panel Troubleshooting	61
Injectors	34	Disassembly	8
Inspection	14	Electronic Governor	69
Low Oil Pressure	43	Electronic Governor Troubleshooting	70
Lubricating Oil Pump	42	Frequency - Adjustment	59
Main Bearing	21	Information	59
Oil Jet (Upper Block)	23	Maintenance	59
Oil Pan	23	Overload Protection Setting	65
Oil Pressure	43	Remote Start/Stop Panel (diagram)	60, 72
Oil Pressure Switch/Sender	43	Shore Power Transfer Switch	71
Overhaul	7	Special Tools	78
Piston and Piston Ring	18	Specifications	76
Push Rod	22	Troubleshooting	68



INDEX

Wiring Diagram	73	Tappets	22
Wiring Schematic	72	Testing for Overhaul	7
Glow Plugs - Testing	38	Timing Gear Cover	23
Heat Exchanger	31	Timing Gear	12
Injection Pump	9, 10	Torques	
Injection Timing	32	Standard Hardware	58
Injectors	32	Specifications	57
L Dimension	15	Westerbeke Components	68
Lubricating Oil Pump	42	Transmission - Oil Coolers	30
Metric Conversion Chart	79	Transmission-Service	8
Oil Pressure	43	Troubleshooting	
Oil Pressure Testing	43	BE Generator	68
Pumps		Control Panel	61
Coolant Circulating	41	Electronic Governor	70
Fuel Lift	31	Engine	3
Injection	30	Fuel System	36
Raw Water (Overhaul)	44	Valve Clearance	28, 39
Raw Water Pump	44	Valve Guide	15
Rear Oil Seal	23	Valve Seat	16
Remote Start/Stop Panel (diagram)	72	Valve Spring	14
Sealants and Lubricants	58	Voltage Regulator	65
Shore Power Transfer Switch	71	Wiring Diagrams/ Schematics	
Special Tools - Generator	76	Generator #039422 (diagram)	73, 74
Specifications - Engines	54	82B Four Engine #039144 (diagram)	52
Specifications - Generators	74	82b Four Engine #039144 (schematic)	53
Standard Hardware	58	BE Single Phase (schematic)	66
Standards and Limits	55	BE Three Phase 12 wire (schematic)	67
Starter Motor	45	BE Three Phase 6 wire(schematic)	63, 66
Starter Motor - Adjustment and Repair	45	Remote Stop/Start Panel(diagram)	72
Tachometer	49	Generator #038422 (schematic)	72

www.torresen.com

www.torresen.com



*WESTERBEKE CORPORATION
MYLES STANDISH INDUSTRIAL PARK
150 JOHN HANCOCK ROAD, TAUNTON, MA 02780-7319*

1008 WMDW 12/98