



OPERATORS MANUAL

WESTERBEKE GASOLINE GENERATOR CARBURETOR MODELS

4.5 KW BCGTC – 60 Hz

3.75 KW BCGTC – 50 Hz

7.2 KW BCGTC – 60 Hz

6.0 KW BCGTC – 50 Hz

9.6 KW BCGTC – 60 Hz

8.0 KW BCGTC – 50 Hz

Single Phase

PUBLICATION 42832
1st Edition / September 1997



WESTERBEKE CORPORATION • AVON INDUSTRIAL PARK
AVON, MA 02322 • TEL: (508) 588-7700 • FAX: (508) 559-9323



Member National Marine Manufacturers Association

 **WARNING:**

Exhaust gasses contain Carbon Monoxide, an odorless and colorless gas. Carbon Monoxide is poisonous and can cause unconsciousness and death. Symptoms of Carbon Monoxide exposure can include:

- *Dizziness*
- *Nausea*
- *Headache*
- *Weakness and Sleepiness*
- *Throbbing in Temples*
- *Muscular Twitching*
- *Vomiting*
- *Inability to Think Coherently*

IF YOU OR ANYONE ELSE EXPERIENCE ANY OF THESE SYMPTOMS, GET OUT INTO THE FRESH AIR IMMEDIATELY. If symptoms persist, seek medical attention. Shut down the unit and do not restart until it has been inspected and repaired.

SAFETY INSTRUCTIONS

INTRODUCTION

Read this safety manual carefully. Most accidents are caused by failure to follow fundamental rules and precautions. Know when dangerous conditions exist and take the necessary precautions to protect yourself, your personnel, and your machinery.

The following safety instructions are in compliance with the American Boat and Yacht Council (ABYC) standards.

PREVENT ELECTRIC SHOCK

⚠ WARNING: Do not touch AC electrical connections while engine is running, or when connected to shore power. Lethal voltage is present at these connections!

- Do not operate this machinery without electrical enclosures and covers in place.
- Shut off electrical power before accessing electrical equipment.
- Use insulated mats whenever working on electrical equipment.
- Make sure your clothing and skin are dry, not damp (particularly shoes) when handling electrical equipment.
- Remove wristwatch and all jewelry when working on electrical equipment.
- Do not connect utility shore power to vessel's AC circuits, except through a ship-to-shore double throw transfer switch. Damage to vessel's AC generator may result if this procedure is not followed.
- Electrical shock results from handling a charged capacitor. Discharge capacitor by shorting terminals together.

PREVENT BURNS — HOT ENGINE

⚠ WARNING: Do not touch hot engine parts or exhaust system components. A running engine gets very hot!

- Always check the engine coolant level at the coolant recovery tank.

⚠ WARNING: Steam can cause injury or death!

- In case of an engine overheat, allow the engine to cool before touching the engine or checking the coolant.

PREVENT BURNS — FIRE

⚠ WARNING: Fire can cause injury or death!

- Prevent flash fires. Do not smoke or permit flames or sparks to occur near the carburetor, fuel line, filter, fuel pump, or other potential sources of spilled fuel or fuel vapors. Use a suitable container to catch all fuel when removing the fuel line; carburetor, or fuel filters.
- Do not operate with a Coast Guard Approved flame arrester removed. Backfire can cause severe injury or death.
- Do not operate with the air cleaner/silencer removed. Backfire can cause severe injury or death.
- Do not smoke or permit flames or sparks to occur near the fuel system. Keep the compartment and the engine/generator clean and free of debris to minimize the chances of fire. Wipe up all spilled fuel and engine oil.
- Be aware — diesel fuel will burn.

PREVENT BURNS — EXPLOSION

⚠ WARNING: Explosions from fuel vapors can cause injury or death!

- Follow re-fueling safety instructions. Keep the vessel's hatches closed when fueling. Open and ventilate cabin after fueling. Check below for fumes/vapor before running the blower. Run the blower for four minutes before starting your engine.
- All fuel vapors are highly explosive. Use extreme care when handling and storing fuels. Store fuel in a well-ventilated area away from spark-producing equipment and out of the reach of children.
- Do not fill the fuel tank(s) while the engine is running.
- Shut off the fuel service valve at the engine when servicing the fuel system. Take care in catching any fuel that might spill. DO NOT allow any smoking, open flames, or other sources of fire near the fuel system or engine when servicing. Ensure proper ventilation exists when servicing the fuel system.
- Do not alter or modify the fuel system.
- Be sure all fuel supplies have a positive shutoff valve.
- Be certain fuel line fittings are adequately tightened and free of leaks.
- Make sure a fire extinguisher is installed nearby and is properly maintained. Be familiar with its proper use. Extinguishers rated ABC by the NFPA are appropriate for all applications encountered in this environment.



SAFETY INSTRUCTIONS

ACCIDENTAL STARTING

⚠ WARNING: Accidental starting can cause injury or death!

- Disconnect the battery cables before servicing the engine/generator. Remove the negative lead first and reconnect it last.
- Make certain all personnel are clear of the engine before starting.
- Make certain all covers, guards, and hatches are re-installed before starting the engine.

BATTERY EXPLOSION

⚠ WARNING: Battery explosion can cause injury or death!

- Do not smoke or allow an open flame near the battery being serviced. Lead acid batteries emit hydrogen, a highly explosive gas, which can be ignited by electrical arcing or by lit tobacco products. Shut off all electrical equipment in the vicinity to prevent electrical arcing during servicing.
- Never connect the negative (-) battery cable to the positive (+) connection terminal of the starter solenoid. Do not test the battery condition by shorting the terminals together. Sparks could ignite battery gases or fuel vapors. Ventilate any compartment containing batteries to prevent accumulation of explosive gases. To avoid sparks, do not disturb the battery charger connections while the battery is being charged.
- Avoid contacting the terminals with tools, etc., to prevent burns or sparks that could cause an explosion. Remove wristwatch, rings, and any other jewelry before handling the battery.
- Always turn the battery charger off before disconnecting the battery connections. Remove the negative lead first and reconnect it last when servicing the battery.

BATTERY ACID

⚠ WARNING: Sulphuric acid in batteries can cause severe injury or death!

- When servicing the battery or checking the electrolyte level, wear rubber gloves, a rubber apron, and eye protection. Batteries contain sulfuric acid which is destructive. If it comes in contact with your skin, wash it off at once with water. Acid may splash on the skin or into the eyes inadvertently when removing electrolyte caps.

TOXIC EXHAUST GASES

⚠ WARNING: Carbon monoxide (CO) is a deadly gas!

- Ensure that the exhaust system is adequate to expel gases discharged from the engine. Check the exhaust system regularly for leaks and make sure the exhaust manifolds are securely attached and no warping exists. Pay close attention to the manifold, water injection elbow, and exhaust pipe nipple.
- Be sure the unit and its surroundings are well ventilated.
- In addition to routine inspection of the exhaust system, install a carbon monoxide detector. Consult your boat builder or dealer for installation of approved detectors.
- For additional information refer to ABYC T-22 (educational information on Carbon Monoxide).

⚠ WARNING: Carbon monoxide (CO) is an invisible odorless gas. Inhalation produces flu-like symptoms, nausea or death!

- Do not use copper tubing in diesel exhaust systems. Diesel fumes can rapidly destroy copper tubing in exhaust systems. Exhaust sulfur causes rapid deterioration of copper tubing resulting in exhaust/water leakage.
- Do not install exhaust outlet where exhaust can be drawn through portholes, vents, or air conditioners. If the engine exhaust discharge outlet is near the waterline, water could enter the exhaust discharge outlet and close or restrict the flow of exhaust. Avoid overloading the craft.
- Although diesel engine exhaust gases are not as toxic as exhaust fumes from gasoline engines, carbon monoxide gas is present in diesel exhaust fumes. Some of the symptoms or signs of carbon monoxide inhalation or poisoning are:

Vomiting
Dizziness
Throbbing in temples
Muscular twitching
Intense headache
Weakness and sleepiness

AVOID MOVING PARTS

⚠ WARNING: Rotating parts can cause injury or death!

- Do not service the engine/generator while it is running. If a situation arises in which it is absolutely necessary to make

SAFETY INSTRUCTIONS

operating adjustments, use extreme care to avoid touching moving parts and hot exhaust system components.

- Do not wear loose clothing or jewelry when servicing equipment; avoid wearing loose jackets, shirts, sleeves, rings, necklaces or bracelets that could be caught in moving parts.
- Make sure all attaching hardware is properly tightened. Keep protective shields and guards in their respective places at all times.
- Do not check fluid levels or the drive belts' tension while the engine/generator is operating.
- Stay clear of the drive shaft and the transmission coupling when the engine is running; hair and clothing can easily be caught in these rotating parts.

HAZARDOUS NOISE

 **WARNING: High noise levels can cause hearing loss!**

- Never operate a generator without its muffler installed.
- Do not run an engine with the air intake (silencer) removed.
- Do not run engines or generators for long periods with their enclosures open.

 **WARNING: Do not work on machinery when you are mentally or physically incapacitated by fatigue!**

OPERATORS MANUAL

Many of the preceding safety tips and warnings are repeated in your Operators Manual along with other cautions and notes to highlight critical information. Read your manual carefully, maintain your equipment, and follow all safety procedures.

GASOLINE ENGINE AND GENERATOR INSTALLATIONS

Preparations to install a gasoline engine or generator should begin with a thorough examination of the American Boat and Yacht Council's (ABYC) standards. These standards are from a combination of sources including the USCG and the NFPA.

Sections of the ABYC standards of particular interest are:

- H-2 Ventilation
- H-24 Gasoline fuel systems
- P-1 Exhaust systems
- P-4 Inboard engines
- E-9 DC Electrical systems

All installations must comply with the Federal Code of Regulations (FCR).

ABYC, NFPA AND USCG PUBLICATIONS FOR INSTALLING GASOLINE AND DIESEL ENGINES AND GENERATORS

Read the following ABYC, NFPA and USCG publications for safety codes and standards. Follow their recommendations when installing your WESTERBEKE engine/generator.

ABYC (American Boat and Yacht Council)
"Safety Standards for Small Craft"

Order From:
ABYC
15 East 26th Street
New York, NY 10010

NFPA (National Fire Protection Association)
"Fire Protection Standard for Motor Craft"

Order From:
NFPA
1 Batterymarch Park
P.O. Box 9101
Quincy, MA 02269-9101

USCG (United States Coast Guard)
"USCG 33CFR183"

Order From:
U.S. Government Printing Office
Washington, D.C. 20404



INSTALLATION

When installing WESTERBEKE engines and generators it is important that strict attention be paid to the following information:

CODES AND REGULATIONS

Strict federal regulations, ABYC guidelines, and safety codes must be complied with when installing engines and generators in a marine environment.

SIPHON-BREAK

For installations where the exhaust manifold/water injected exhaust elbow is close to or below the vessel's waterline, provisions must be made to install a siphon-break in the raw water supply hose to the exhaust elbow. This hose must be looped a minimum of 18" above the vessel's waterline. *Failure to use a siphon-break when the exhaust manifold injection port is at or below the load waterline will result in raw water damage to the engine and possible flooding of the boat.*

EXHAUST SYSTEM

The exhaust hose must be certified for marine use. The system must be designed to prevent water from entering the exhaust under any sea conditions and at any angle of the vessels hull.

A detailed 40 page Marine Installation Manual covering gasoline and diesel, engines and generators, is available from your WESTERBEKE dealer.



Declaration of Conformity

Application of Council Directive(s) **EMC 89/336/EEC**
ISO 8846 1990(E)

Standard(s) to Which Conformity is declared **EN50081-1**
EN50082-2
EN55020
ISO-8846-1990(E), Certification Number, IWES003

Manufacturers Name **Westerbeke Corporation**

Manufacturers Address **41 Ledin Drive**
Avon Industrial Park
Avon, Ma. 02322, USA

Type of Equipment **Marine Gasoline Generator**

Product Name **Westerbeke Marine Gasoline Generator**

Model(s) **3.7/4.5BCGTE, 6.0/7.2BCGTE**
8.0/9.6BCGTE, 3.7/4.5BCGTC, 6.0/7.2BCGTC & 8.0/9.6BTGTC

Product Options **All**

Supplementary Information

- 1.) The equipment listed is only for use in Marine Applications aboard boats.
- 2.) The equipment listed must be located below decks on the vessel and permanently installed in it's location.
- 3.) The equipment listed must be wired to the grounding system of the vessel.

I the undersigned, hereby declare that the equipment specified above conforms to the above Directive(s) and Standard(s).

Place Avon, Massachusetts, U.S.A.

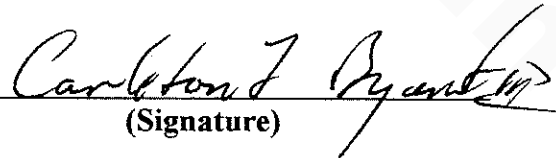
(Signature)

Date: September 1, 1996

Carleton F. Bryant
(Full Name)

Chief Operating Officer
(Title)

INTERNATIONAL MARINE CERTIFICATION INSTITUTE

Trèves Centre, Rue de Trèves 45
 B - 1040 BRUXELLES
 BELGIQUE
 tel: +32 (0) 2-238-7892
 fax: +32 (0) 2-238-7700



CERTIFICATE

We hereby certify the component stated below meets the EC Directive 94/25/EC for type-examination in accordance with ISO 8846 and has following characteristics:

| | |
|--------------|--|
| TYPE | Gasoline Marine Generator |
| MANUFACTURER | Westerbeke Corp. |
| ADDRESS | Avon Industrial Park, Avon, MA 02333 USA |

| GROUP OF | +++++ | +++++ | +++++ |
|----------|---------------|-------|-------|
| Model 1 | 3.7/4.5 BCGTE | +++++ | +++++ |
| Model 2 | 6.0/7.2 BCGTE | +++++ | +++++ |
| Model 3 | 8.0/9.6 BCGTE | +++++ | +++++ |
| Model 4 | 3.7/4.5 BCGTC | +++++ | +++++ |
| Model 5 | 6.0/7.2 BCGTC | +++++ | +++++ |
| Model 6 | 8.0/9.6 BCGTC | +++++ | +++++ |
| Model 7 | +++++ | +++++ | +++++ |
| Model 8 | +++++ | +++++ | +++++ |
| Model 9 | +++++ | +++++ | +++++ |
| Model 10 | +++++ | +++++ | +++++ |
| Model 11 | +++++ | +++++ | +++++ |
| Model 12 | +++++ | +++++ | +++++ |
| Model 13 | +++++ | +++++ | +++++ |
| Model 14 | +++++ | +++++ | +++++ |
| Model 15 | +++++ | +++++ | +++++ |
| Model 16 | +++++ | +++++ | +++++ |
| Model 17 | +++++ | +++++ | +++++ |
| Model 18 | +++++ | +++++ | +++++ |
| Model 19 | +++++ | +++++ | +++++ |
| Model 20 | +++++ | +++++ | +++++ |
| Model 21 | +++++ | +++++ | +++++ |
| Model 22 | +++++ | +++++ | +++++ |
| Model 23 | +++++ | +++++ | +++++ |

| | |
|----------------------|-------------------------|
| Certification number | IVES003 |
| Signed | <i>Lars E. Granholm</i> |
| Name | Lars E. Granholm |
| Title | Managing Director |
| EU Notified Body No. | 0609 |
| Date | 02/02/1998 |

TABLE OF CONTENTS

| | | | |
|--|----|---|----|
| Introduction | 2 | Engine Lubricating Oil | 16 |
| Warranty Procedures..... | 2 | Description..... | 16 |
| Customer Identification Card..... | 2 | Changing the Engine Oil..... | 16 |
| Product Software..... | 2 | Replacing the Oil Filter..... | 16 |
| Serial Number Location..... | 2 | Refilling the Oil Sump..... | 16 |
| Ordering Parts..... | 3 | Remote Oil Filter (Optional) | 17 |
| Notes, Cautions and Warnings..... | 3 | Installation..... | 17 |
| Protecting Your Investment..... | 3 | DC Electrical System | 18 |
| Spares and Accessories..... | 3 | 12-Volt DC Control Circuit..... | 18 |
| Control Panels | 4 | Batteries..... | 18 |
| Generator Panel..... | 4 | Specifications..... | 18 |
| Remote Panel..... | 4 | Battery Maintenance..... | 18 |
| Overspeed Circuit Board..... | 4 | Battery Charging..... | 18 |
| Safety Shutdown Switches | 5 | Component Testing..... | 18 |
| Safety Shutdown Switches..... | 5 | Wiring Diagram #42834..... | 19 |
| High Exhaust Temperature Switch..... | 5 | Wiring Schematic #42834..... | 20 |
| High Water Temperature Switch..... | 5 | Wiring Diagram #42857 Remote Panel(s)..... | 21 |
| Low Oil Pressure Switch..... | 5 | Engine Adjustments | 22 |
| Engine Circuit Breaker..... | 5 | Engine Speed (Hertz) Adjustment..... | 22 |
| Fuel, Engine Oil and Engine Coolant | 6 | Governor..... | 22 |
| Gasoline..... | 6 | Governor Adjustments..... | 22 |
| Care of the Fuel Supply..... | 6 | Governor Maintenance..... | 22 |
| Engine Oil..... | 6 | Torquing the Cylinder Head Bolts..... | 22 |
| Engine Coolant..... | 6 | Valve Clearance Adjustment..... | 22 |
| Coolant Recovery Tank..... | 6 | Choke Solenoid..... | 23 |
| Preparations for Initial Start-Up | 7 | Ignition Timing..... | 23 |
| Prestart Inspection..... | 7 | Spark Plugs..... | 23 |
| Operating Instructions | 8 | Carburetor Adjustment..... | 24 |
| Generator Panel..... | 8 | Drive Belts Adjustment..... | 24 |
| Starting the Generator..... | 8 | Timing Belt Inspection and Replacement..... | 25 |
| Stopping the Generator..... | 8 | Engine Troubleshooting | 29 |
| Remote Panel..... | 8 | Generator Information | 31 |
| Starting the Generator..... | 8 | Use of Electric Motors..... | 31 |
| Stopping the Generator..... | 8 | Required Operating Speed..... | 31 |
| Emergency Stopping..... | 8 | Generator Frequency Adjustment..... | 31 |
| Starting Under Cold Conditions..... | 8 | Generator Maintenance..... | 31 |
| Abnormal Stop..... | 8 | Generator Wiring Diagrams | 32 |
| Break-In Procedure/Daily Operation | 9 | AC Electrical Connections | 33 |
| Break-In Procedure..... | 9 | Lay-Up & Recommissioning | 34 |
| Check List..... | 9 | General..... | 34 |
| Stopping the Generator..... | 9 | Fresh Water Cooling System..... | 34 |
| Generator Adjustments..... | 9 | Lubrication System..... | 34 |
| Maintenance Schedule | 10 | Fuel System..... | 34 |
| Engine Cooling Circuit | 12 | Raw Water Circuit..... | 34 |
| Description..... | 12 | Intake Manifold..... | 35 |
| Thermostat..... | 13 | Starter Motor..... | 35 |
| Thermostat Test..... | 13 | Cylinder Lubrication..... | 35 |
| Draining the Coolant..... | 13 | Spare Parts..... | 35 |
| Refilling the Coolant..... | 13 | Batteries..... | 35 |
| Raw Water Pump..... | 14 | Recommissioning..... | 35 |
| Changing the Raw Water Pump Impeller..... | 14 | BCGTC Generator Specifications | 36 |
| Heat Exchanger..... | 14 | BCGTC Generator Parts Identification | 37 |
| Drive Belt Adjustment..... | 14 | Standard Hardware Torques | 38 |
| Fuel System | 15 | BCGTC Generator Hardware Torques | 39 |
| Gasoline..... | 15 | Metric Conversions | 40 |
| Carburetor..... | 15 | Suggested Spare Parts | 41 |
| Gasoline/Water Separator and Filter..... | 15 | | |
| Fuel Pump..... | 15 | | |
| Gasdenser..... | 15 | | |



INTRODUCTION

This WESTERBEKE Generator is a product of WESTERBEKE'S long years of experience and advanced technology. We take great pride in the superior durability and dependable performance of our engines and generators. Thank you for selecting WESTERBEKE.

In order to get the full use and benefit from your generator, it is important that you operate and maintain it correctly. This manual is designed to help you do this. Please read this manual carefully and observe all the safety precautions throughout. Should your engine require servicing, contact your nearest WESTERBEKE dealer for assistance.

This is your Operators Manual. A Parts Catalog is also provided and a Technical Manual is available from your WESTERBEKE dealer. Also, if you are planning to install this equipment yourself, contact your WESTERBEKE dealer for WESTERBEKE'S Installation Manual.

WARRANTY PROCEDURES

Your WESTERBEKE Warranty is included in a separate folder. If you have not received a customer identification card registering your warranty 60 days after submitting the warranty registration form, please contact the factory in writing with model information, including the unit's serial number and commission date.

WESTERBEKE CANNOT BE RESPONSIBLE FOR THE CONTENT OF SUCH SOFTWARE, MAKES NO WARRANTIES OR REPRESENTATIONS WITH RESPECT THERETO, INCLUDING ACCURACY, TIMELINESS OR COMPLETENESS THEREOF AND WILL IN NO EVENT BE LIABLE FOR ANY TYPE OF DAMAGE OR INJURY INCURRED IN CONNECTION WITH OR ARISING OUT OF THE FURNISHING OR USE OF SUCH SOFTWARE.

WESTERBEKE customers should also keep in mind the time span between printings of WESTERBEKE product software and the unavoidable existence of earlier WESTERBEKE manuals. In summation, product software provided with WESTERBEKE products, whether from WESTERBEKE or other suppliers, must not and cannot be relied upon exclusively as the definitive authority on the respective product. It not only makes good sense but is imperative that appropriate representatives of WESTERBEKE or the supplier in question be consulted to determine the accuracy and currentness of the product software being consulted by the customer.

SERIAL NUMBER LOCATION

The *generator* serial number and model number is located on a decal on the the generator housing. Take the time to enter the information on the blank decal provided. This will provide a quick reference when seeking technical information and/or ordering parts.



Customer Identification

WESTERBEKE OWNER
MAIN STREET
HOMETOWN, USA

Model BCGTC Ser. #D703XXXX
Expires 9/20/02

CUSTOMER IDENTIFICATION CARD (Typical)

The WESTERBEKE serial number is an alphanumeric number that can assist in determining the date of manufacture of your WESTERBEKE engine/generator. The first character indicates the decade (A=1960s, B=1970s, C=1980s, D=1990s), the second character represents the year in the decade, and the fourth and fifth number represents the month of manufacture.

PRODUCT SOFTWARE

Product software (tech data, parts lists, manuals, brochures and catalogs) provided from sources other than WESTERBEKE are not within WESTERBEKE'S CONTROL.

| SPECIFICATION | 50 HZ. | 60 HZ. |
|------------------|--------|--------|
| MODEL | | |
| RPM | | |
| KW | | |
| KVA | | |
| VOLTS | | |
| AMPS | | |
| ENG. HP | | |
| ENG. SER. NO. | | |
| GEN. SER. NO. | | |
| PF/PHASE | / | |
| WIRES | | |
| RATING | | |
| INSUL. CLASS .. | | |
| TEMP. RISE | | |
| BATTERY | | |
| C.I.D. | | |



INTRODUCTION

The *engine* model number and serial number are located on a plate mounted on the engine's valve cover.



ORDERING PARTS

Whenever replacement parts are needed, always provide the generator and engine model and serial numbers. In addition, include a complete part description and part number for each part needed (see the separately furnished Parts Catalog). Also insist upon WESTERBEKE packaged parts because *will fit* or generic parts are frequently not made to the same specifications as original equipment.

NOTES, CAUTIONS AND WARNINGS

As this manual takes you through the operating procedures, maintenance schedules, and troubleshooting of your generator, critical information will be highlighted by NOTES, CAUTIONS, and WARNINGS. An explanation follows:

NOTE: *An operating procedure essential to note.*

CAUTION: *Procedures, which if not strictly observed, can result in the damage or destruction of the engine or generator.*

WARNING: *Procedures, which if not properly followed, can result in personal injury or loss of life.*

PROTECTING YOUR INVESTMENT

Care at the factory during assembly and thorough testing have resulted in a WESTERBEKE generator capable of many thousands of hours of dependable service. However the manufacturer cannot control how or where the generator is installed in the vessel or the manner in which the unit is operated and serviced in the field. This is up to the buyer/owner-operator.

NOTE: *Six important steps to ensure long generator life:*

- *Proper engine and generator installation and alignment.*
- *An efficient well-designed exhaust system that includes an anti-siphon break to prevent water from entering the engine.*
- *Changing the engine oil and oil filters every 100 operating hours.*
- *Proper maintenance of all engine and generator components according to the maintenance schedule in this manual.*
- *Use clean, filtered unleaded fuel.*
- *Winterize your engine according to the "Lay-up and Recommissioning" section in this manual.*

SPARES AND ACCESSORIES

Certain spare parts will be needed to support and maintain your WESTERBEKE generator or engine when cruising (see *SUGGESTED SPARE PARTS*). Often even simple items such as proper fuel and oil filter can be difficult to obtain along the way. WESTERBEKE will provide you with a suggested spares and accessories brochure to assist you in preparing an on-board inventory of the proper WESTERBEKE parts.

CONTROL PANELS

GENERATOR PANEL

The ON and START/OFF switches are the only functional components to operate the generator at the engine. Both switches are used to start the generator – see *Starting the Generator* under *OPERATING INSTRUCTIONS*.

The ON switch is a two-position switch with momentary contacts in the up (*on*) position and a stationary contact function in the center position. This switch energizes the fuel pump.

The START/OFF switch is a three-position switch with momentary contact functions in the up (*start*) and down (*off*) positions, and a stationary contact function in the center position. When in the center (normal) position, this switch allows the generator to be run, once started. When in the up (*start*) position (together with the ON switch in the up position), this switch starts the generator, and once released, reverts to the center position. When in the down (*off*) position, this switch stops the engine in normal operation as well as in an emergency situation.

When maintenance is being performed on the generator, the 8 amp fuse should be removed. This will disable the remote control panel(s), preventing attempts to start the generator from their locations. However, it is always best to disconnect the battery during this time if it is not required to perform the maintenance.

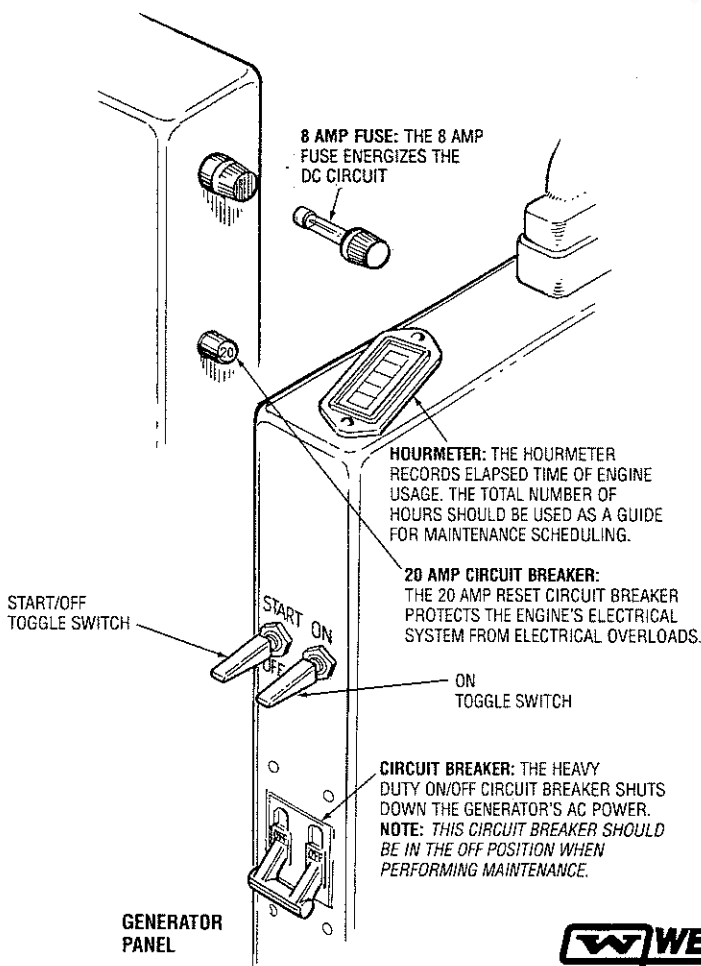

REMOTE PANEL

There are three functional components on the remote panel for generator operation:

1. ON switch
2. START/STOP switch
3. Green LED indicator light

The ON switch is a two-position switch with momentary contact functions in the up (*on*) position and a stationary contact function in the center position. This switch energizes the fuel pump.

The START/STOP switch is a three-position switch with momentary contact functions in the up (*start*) and down (*stop*) positions, and a stationary contact function in the center position. The center position is a dual *off/run* mode position and is normally in the *off* mode. When in the *start* (up) position, this switch starts the generator (together with the ON switch in the up position) and once released, reverts to the center position, *run* mode. When in the *stop* (down) position, this switch stops the generator, and once released, reverts to the center position, *off* mode.

The Green LED indicator light indicates the engine running condition. It lights when the ON switch is moved to the *start* position, dims when the engine is cranking, and brightens when the engine starts, notifying the operator to release the START switch.

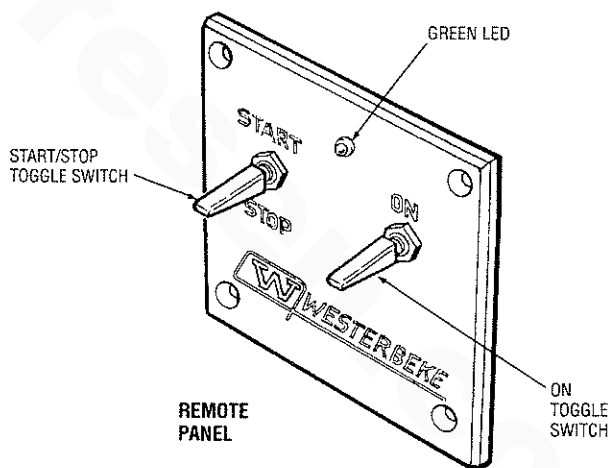

OVERSPEED CIRCUIT BOARD

The overspeed circuit board senses the engine speed through pulses off the engine coil. If the engine speed exceeds 3800 rpm, this overspeed circuit will activate, and will interrupt DC power to the K2 relay shutting the engine down. It has an automatic reset.

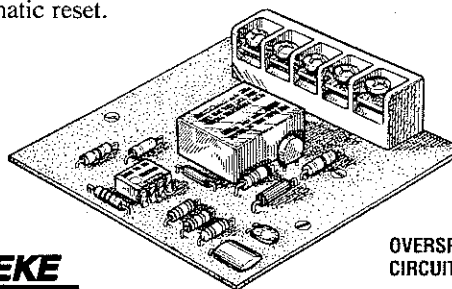

SAFETY SHUTDOWN SWITCHES

SAFETY SHUTDOWN SWITCHES

The engine is protected by three automatic shutdown switches. Should a shutdown occur, *do not attempt to restart without finding and correcting the cause*. Refer to the heading *Engine starts, runs and then shuts down* in the *ENGINE TROUBLESHOOTING* section of this manual.

The following is a description of these automatic shutdown switches:

High Exhaust Temperature Switch

An exhaust temperature switch is located on the exhaust elbow. Normally closed, this switch will open and interrupt the DC voltage to the K2-run relay (shutting off the engine) should the switch's sensor indicate an excessive exhaust temperature (an inadequate supply of raw water causes high exhaust temperatures). This switch opens at 260-270°F (127-132°C). This switch resets at approximately 225°F (107°C).

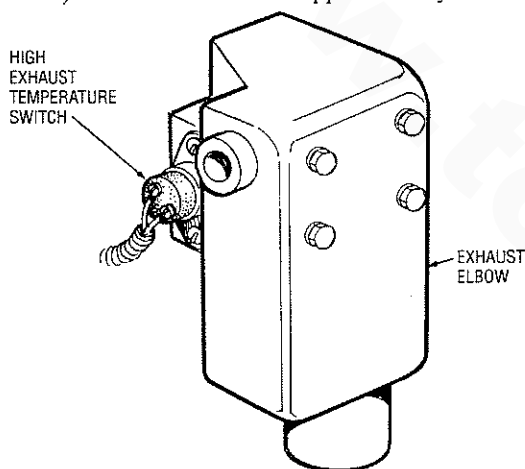

High Water Temperature Switch

A high water temperature switch is located at the thermostat housing. Normally closed, this switch, should the fresh water coolant's operating temperature reach approximately 210°F (99°C), will open and interrupt the DC voltage to the K2-run relay thereby shutting off the engine. This switch resets at 195°F (107°C).

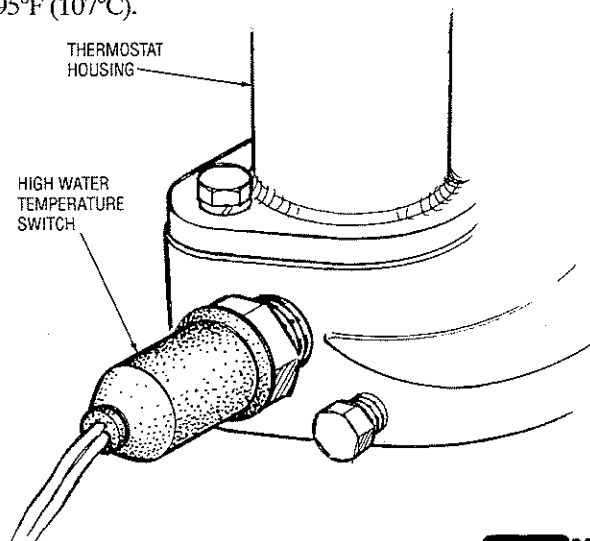

Low Oil Pressure Switch

A low oil pressure shutdown switch is located off the engine's oil gallery. Normally open in a static state, this switch's sensor monitors the engine's oil pressure. Should the engine's oil pressure fall to 5-10 psi, this switch will open interrupting the DC voltage to the K2-run relay thereby shutting off the engine.

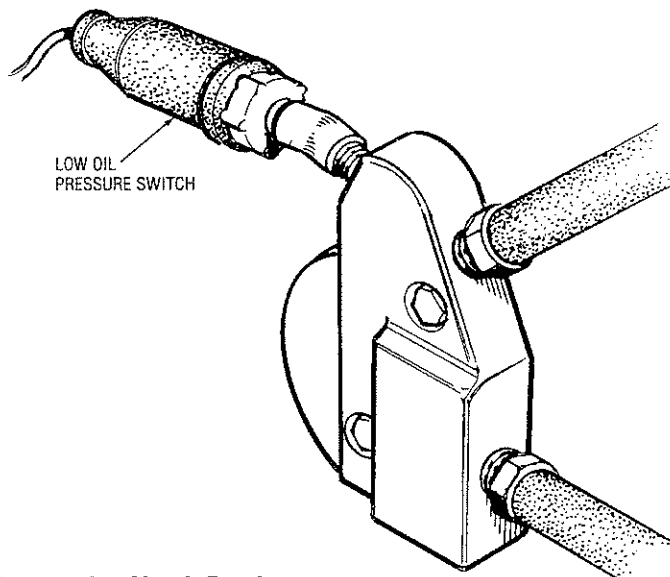

Engine Circuit Breaker

The generator's engine is protected by an engine mounted manual reset circuit breaker (20 amps DC). Excessive current draw or electrical overload anywhere in the instrument panel wiring or engine wiring will cause the breaker to trip. In this event the generator will shut down because the opened breaker interrupts the DC circuit to the K2-run relay. If this should occur, check and repair the source of the problem. After repairing the fault, reset the breaker and restart the generator.

FUEL, ENGINE OIL AND ENGINE COOLANT

GASOLINE

CAUTION: Only use unleaded fuel with an octane rating of 89 or higher. Leaded fuel will cause serious harm to your engine and violate your warranty.

CARE OF THE FUEL SUPPLY

Use only clean fuel! The clearance of the components in your carburetor is very critical; invisible dirt particles which might pass through the filter can damage these finely finished parts. It is important to buy clean fuel, and keep it clean. The best fuel can be rendered unsatisfactory by careless handling or improper storage facilities. To assure that the fuel going into the tank for your engine's daily use is clean and pure, the following practice is advisable:

Purchase a well-known brand of fuel.

Install and regularly service a good, Coast Guard approved metal bowl type filter/water separator between the fuel tank and the engine.

ENGINE OIL

Use a heavy duty engine oil with an API classification of SJ. Change the engine oil after an initial 50 hours of break-in operation, and every 100 hours of operation thereafter. For recommended oil viscosity, see the following chart:

| Operating Temperature | Oil Viscosity |
|------------------------|--------------------------|
| Above 68° F (20° C) | SAE 30, 10W-30 or 15W-40 |
| 41° - 68° F (5°-20° C) | SAE 20 or 10W-30 |
| Below 41° F (5° C) | SAE 10W-30 |

CAUTION: Do not allow two or more brands of engine oil to mix. Each brand contains its own additives; additives of different brands could react in the mixture to produce properties harmful to your engine.

ENGINE COOLANT

Westerbeke recommends a mixture of 50% antifreeze and 50% distilled water, when possible. Distilled water is free from the chemicals that can corrode internal engine surfaces.

The antifreeze performs double duty, as it allows the engine to run at proper temperatures by transferring heat away from the engine to the coolant. It also lubricates and protects the cooling circuit from rust and corrosion. Use a good quality antifreeze that contains supplemental cooling additives (SCAs) that keep the antifreeze chemically balanced, crucial to long term protection.

The water and antifreeze should be pre-mixed before being poured into the cooling circuit.

NOTE: Use the new environmentally-friendly long lasting antifreeze that is now available.

ANTIFREEZE PROTECTION CHART

| Antifreeze concentration | 23% | 30% | 35% | 50% |
|--------------------------|---------|---------|---------|---------|
| Freezing Temperature | 14° F | 8° F | -4° F | -40° F |
| | (-10°C) | (-13°C) | (-20°C) | (-40°C) |

COOLANT RECOVERY TANK

A coolant recovery tank kit is supplied with each generator. The purpose of this recovery tank is to allow for engine coolant expansion and contraction, during engine operation, without the loss of coolant and without introducing air into the cooling system.

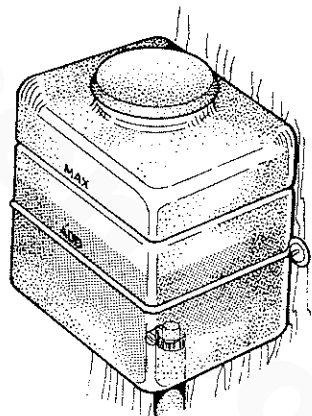

COOLANT RECOVERY TANK

PREPARATIONS FOR INITIAL START-UP

PRESTART INSPECTION

Before starting your generator for the first time or after a prolonged layoff, check the following items:

- Check the engine oil level: add oil to maintain the level at the full mark on the dipstick.
- Check the fuel supply and examine the fuel filter/separator bowls for contaminants.
- Check the DC electrical system. Inspect wire connections and battery cable connections.
- Check the coolant level in both the plastic recovery tank and at the manifold.

NOTE: After the initial running of the generator, the air in the engine's cooling system will be purged to the coolant recovery tank. After shutdown and after the engine has cooled, the coolant from the recovery tank will be drawn into the engine's cooling system to replace the purged air.

Before subsequent operation of the generator, the engine's manifold should be topped off, and the coolant recovery tank may need to be filled to the MAX level.

- Visually examine the unit. Look for loose or missing parts, disconnected wires, unattached hoses, and check threaded connections. Search for any gasoline leaks.
- Check load leads for correct connections as specified in the wiring diagrams.
- Examine the air inlet and outlet for air flow obstructions.
- Be sure no other generator or utility power is connected to the load lines.
- Be sure that in power systems with a neutral line that the neutral is properly grounded (or ungrounded) as the system requires, and that generator neutral is properly connected to the load neutral. In single phase systems an incomplete or open neutral can supply the wrong line-to-neutral voltage on unbalanced loads.

CAUTION: When starting the generator, it is recommended that all AC loads, especially large motors, be switched OFF until the engine has come up to speed and, in cold climates, starts to warm up. This precaution will prevent damage caused by unanticipated operation of the AC machinery and will prevent a cold engine from stalling.

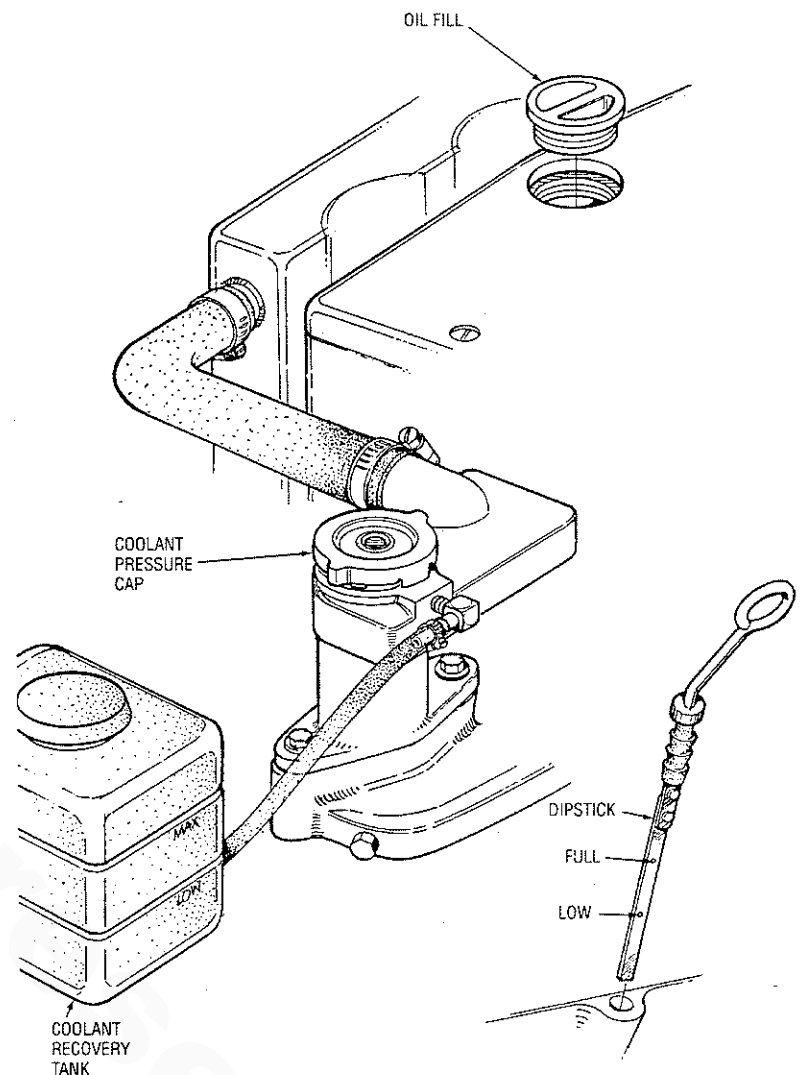

OPERATING INSTRUCTIONS

GENERATOR PANEL

Starting the Generator

To start the generator, hold the momentary ON switch in the up (*on*) position, then hold the momentary START/OFF switch in the up (*start*) position (both switches are held up together). After approximately one second the starter will engage and the engine will crank. Once the engine is running, the starter will disengage, and the START/OFF switch may then be released to return to its center (*run mode*) position. Continue holding the ON switch until the engine has sufficient oil pressure, then release it to its center position.

NOTE: Should the engine fail to start, release both switches, wait 20 seconds, and try again. Never run the starter more than 20 seconds at a time.

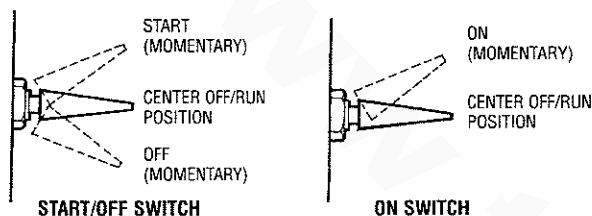

Stopping the Generator

To stop the generator, move the momentary START/OFF switch to the down (*off*) position then release it to the center (normal) position.

REMOTE PANEL

Starting the Generator

To start the generator, hold the momentary ON switch in the up (*on*) position (the green light will come on), then hold the momentary START/STOP switch in the up (*start*) position (both switches are held up together). After approximately one second the starter will engage and the engine will crank (the green light will dim). Once the engine is running (the green light will brighten), the starter will disengage and the START/STOP switch may then be released to return to its center (*run mode*) position. Continue holding the ON switch until the engine has sufficient oil pressure, then release it to its center position.

NOTE: Should the engine fail to start, release both switches, wait 20 seconds, and try again. Never run the starter more than 20 seconds at a time.

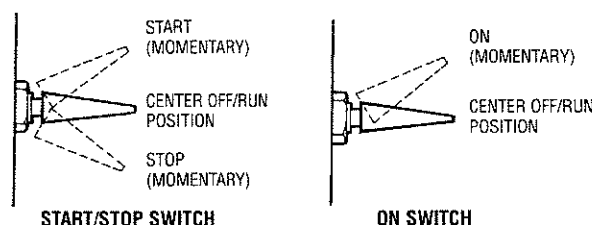

Stopping the Generator

To stop the generator, move the momentary START/STOP switch to the down (*stop*) position then release it to the center (*off/run mode*) position. This will activate the remote control panel for START/STOP functions.

CAUTION: Prolonged cranking intervals without the engine starting can result in filling the engine exhaust system with raw water. This may happen because the pump is pumping raw water through the raw water cooling system during cranking. This raw water can enter the engine's cylinders by way of the exhaust manifold once the exhaust system fills. Prevent this from happening by closing the raw water supply through-hull shutoff, draining the exhaust muffler, and correcting the cause of the excessive engine cranking. Engine damage resulting from raw water entry is not a warrantable issue; the owner/operator should keep this in mind.

EMERGENCY STOPPING

If the generator does not stop using the START/OFF switch, remove the 8 amp fuse or disconnect the battery.

STARTING UNDER COLD CONDITIONS

Make certain the lubricating oil conforms with the ratings for the prevailing temperature. Check the table under *ENGINE LUBRICATING OIL*. The battery should be fully charged to minimize voltage drop.

ABNORMAL STOP

An abnormal stop is one in which the generator ceases to run and comes to a stop as a result of an operating fault which may cause damage to the engine, the generator, or create an unsafe operating condition. The fault stop conditions are:

1. Overspeed condition.
2. High engine temperature.
3. Low oil pressure.
4. High exhaust temperature.

Should a fault condition occur, the engine will shut down and the green LED light on the remote panel will go off indicating that a fault has occurred. Once detected, the fault should be located (see *ENGINE TROUBLESHOOTING*).

BREAK-IN PROCEDURE/DAILY OPERATION

BREAK-IN PROCEDURE

Once the generator has been started, check for proper operation and then encourage a fast warm-up. Run the generator between 20% to 60% of full load for the first 10 hours.

CAUTION: Do not attempt to break-in your generator by running without a load.

After the first 10 hours of the generators' operation, the load can be increased to the full-load rated output; then periodically vary the load.

Avoid overload at all times. An overload is signaled by a smoky exhaust with reduced output voltage and frequency. Monitor the current being drawn from the generator and keep it within the generators' rating. Since the generator operates at 3600 rpm to produce 60 hertz, or at 3000 to produce 50 hertz, control of the generator's engine break-in is governed by the current drawn from the generator.

To protect against unintentional overloading of the generator, the generator's output leads should be routed through a circuit breaker that is rated at the rated output of the generator.

NOTE: Be aware of motor starting loads and the high current drawn required for starting motors. This starting amperage drawn can be 3 to 5 times normal running amperage (see GENERATOR INFORMATION).

CHECK LIST

Follow this checklist each day before starting your generator.

- Record the hourmeter reading in your log (engine hours relate to the maintenance schedule).
- Visually inspect the engine for fuel, oil, or water leaks.
- Check the oil level (dipstick).
- Check the coolant level in the coolant recovery tank.
- Check your fuel supply.
- Check the starting batteries (weekly).
- Check the drive belts for wear and proper tension (weekly).
- Monitor the control panel gauges.
- Check for abnormal noise such as knocking, friction, vibration and blow-back sounds.
- Confirm exhaust smoke:
When the engine is cold – White Smoke.
When the engine is warm – almost Smokeless.
When the engine is overloaded – some Black Smoke.

NOTE: Some unstable running may occur in a cold engine. This condition should abate as normal operating temperature is reached and leads are applied.

CAUTION: Do not operate the generator for long periods of time without a load being placed on the generator.

STOPPING THE GENERATOR

Remove the major AC loads from the generator one at a time. Allow the generator to run for a few minutes to stabilize the operating temperature, (then see *Stopping the Generator* under OPERATING INSTRUCTIONS).

NOTE: After the first 50 hours of generator operation check the maintenance schedule for the 50 hour service check.

GENERATOR ADJUSTMENTS

Once the generator has been placed in operation, there may be governor adjustments required for engine speed (hertz) during the engine's break-in period (first 50 hours) or after this period (see ENGINE SPEED (HERTZ) ADJUSTMENT under ENGINE ADJUSTMENTS). A no-load voltage adjustment may also be required in conjunction with the engine's speed adjustment (see GENERATOR INFORMATION).

MAINTENANCE SCHEDULE

⚠ WARNING: *Never attempt to perform any service while the engine is running. Wear the proper safety equipment such as goggles and gloves, and use the correct tools for each job. Disconnect the battery terminals when servicing any of the engine's DC electrical equipment.*

NOTE: *Many of the following maintenance procedures are simple but others are more difficult and may require the expert knowledge of a service mechanic.*

| SCHEDULED MAINTENANCE | CHECK EACH DAY | HOURS OF OPERATION | | | | | | | EXPLANATION OF SCHEDULED MAINTENANCE |
|--|------------------------------------|---|--------------------------|--------------------------|--------------------------|--------------------------|--------------------------|--------------------------|--|
| | | 50 | 100 | 250 | 500 | 750 | 1000 | 1250 | |
| Fuel Supply | <input type="checkbox"/> | | | | | | | | Unleaded gasoline with octane rating of 89 or higher. |
| Fuel/Water Separator | <input type="checkbox"/> | | | | | | | | Check for water and dirt in fuel (drain/replace filter if necessary). |
| Engine Oil Level | <input type="checkbox"/> | | | | | | | | Oil level should indicate between FULL and LOW on dipstick. |
| Coolant Level | <input type="checkbox"/> | | | | | | | | Check at recovery tank; if empty, check at manifold. Add coolant if needed. |
| Drive Belts | <input type="checkbox"/> Weekly | | | | | | | | Inspect for proper tension (3/8" to 1/2" deflection) and adjust if needed. Check belt edges for wear. |
| Visual Inspection of Engine | <input type="checkbox"/> | NOTE: <i>Keep engine surface clean. Dirt and oil will inhibit the engine's ability to remain cool.</i> | | | | | | | Check for fuel, oil and water leaks. Inspect wiring and electrical connections. Keep bolts & nuts tight. Check for loose belt tension. |
| Spark Plugs | | <input type="checkbox"/> | | <input type="checkbox"/> | <input type="checkbox"/> | <input type="checkbox"/> | <input type="checkbox"/> | <input type="checkbox"/> | Check gap; inspect for burning and corrosion. |
| Generator | | <input type="checkbox"/> | <input type="checkbox"/> | <input type="checkbox"/> | <input type="checkbox"/> | <input type="checkbox"/> | <input type="checkbox"/> | <input type="checkbox"/> | Check that AC connections are clean and secure with no chafing – see <i>GENERATOR INFORMATION</i> for additional information. |
| Carburetor Filter Screen | | <input type="checkbox"/> | | <input type="checkbox"/> | <input type="checkbox"/> | <input type="checkbox"/> | <input type="checkbox"/> | <input type="checkbox"/> | Initial change at 50 hrs, then change every 250 hrs. |
| Starting Batteries (and House Batteries) | <input type="checkbox"/> Weekly | <input type="checkbox"/> | | | | | | | Every 50 operating hours check electrolyte levels and make sure connections are very tight. Clean off excessive corrosion. |
| Engine Oil | | <input type="checkbox"/> | <input type="checkbox"/> | <input type="checkbox"/> | <input type="checkbox"/> | <input type="checkbox"/> | <input type="checkbox"/> | <input type="checkbox"/> | Initial engine oil & filter change at 50 hrs., then change both every 100 hours. |
| *Adjust the Valve Clearances | | <input type="checkbox"/> | | | <input type="checkbox"/> | | <input type="checkbox"/> | | Initial adjustment at 50 hrs., then every 500 hrs. |
| Air Screen (Flame Arrester) | | <input type="checkbox"/> | | | | | | | Clean at 50 hours, then every 100 hours. |
| Exhaust System | | <input type="checkbox"/> | | <input type="checkbox"/> | | <input type="checkbox"/> | | <input type="checkbox"/> | Initial check at 50 hrs., then every 250 hrs. Inspect for leaks. Check siphon break operation. Check the exhaust elbow for carbon and/or corrosion buildup on inside passages; clean and replace as necessary. Check that all connections are tight. |
| Engine Hoses | | | <input type="checkbox"/> | <input type="checkbox"/> | <input type="checkbox"/> | <input type="checkbox"/> | <input type="checkbox"/> | <input type="checkbox"/> | Hose should be hard & tight. Replace if soft or spongy. Check and tighten all hose clamps. |
| Governor | | | | <input type="checkbox"/> | <input type="checkbox"/> | <input type="checkbox"/> | <input type="checkbox"/> | <input type="checkbox"/> | Change oil every 250 hours. Lubricate linkage arm periodically. |

*WESTERBEKE recommends this service be performed by an authorized mechanic.

(continued)



MAINTENANCE SCHEDULE

NOTE: Use the engine hourmeter gauge to log your engine hours or record your engine hours by running time.

| SCHEDULED MAINTENANCE | CHECK EACH DAY | HOURS OF OPERATION | | | | | | | EXPLANATION OF SCHEDULED MAINTENANCE |
|--|----------------|--------------------------|--------------------------|--------------------------|--------------------------|--------------------------|--------------------------|--------------------------|--|
| | | 50 | 100 | 250 | 500 | 750 | 1000 | 1250 | |
| Heat Exchanger | | <input type="checkbox"/> | <input type="checkbox"/> | <input type="checkbox"/> | <input type="checkbox"/> | <input type="checkbox"/> | <input type="checkbox"/> | <input type="checkbox"/> | Clean or replace anode. Open heat exchanger end cap and clean out debris. Remove every 1000 hours for professional cleaning and pressure testing. |
| Raw Water Pump | | | | <input type="checkbox"/> | | <input type="checkbox"/> | | <input type="checkbox"/> | Remove pump cover and inspect impeller for wear; replace if needed. Also replace gasket. Lubricate both when reassembling. |
| Coolant System | | | | | | <input type="checkbox"/> | | | Drain, flush, and refill cooling system with appropriate antifreeze mix. |
| *Starter Motor | | | | | <input type="checkbox"/> | | | <input type="checkbox"/> | Check solenoid and motor for corrosion. Remove and lubricate. Clean and lubricate the Start motor pinion drive. |
| Distributor | | <input type="checkbox"/> | | | <input type="checkbox"/> | | | | Check ignition timing. Check condition of distributor cap and rotor. |
| *Engine Cylinder Compression and Valve Clearance | | | | | <input type="checkbox"/> | | | <input type="checkbox"/> | Incorrect valve clearance will result in poor engine performance; check compression pressure and timing, and adjust valve clearances. |
| *Engine Timing Belt | | | | | | | <input type="checkbox"/> | | Remove and replace. |
| | | | | | | | | | NOTE: Failure to replace the timing belt at the recommended interval could result in timing belt failure resulting in major damage to the engine. |
| *Exhaust Elbow | | | | | <input type="checkbox"/> | | | | Test exhaust elbow for casting integrity. Replace if casting is corroded or deteriorated. WARNING: A defective exhaust elbow can cause carbon monoxide leakage! |

*WESTERBEKE recommends this service be performed by an authorized mechanic.



ENGINE COOLING CIRCUIT

DESCRIPTION

The generator's engine is fresh water cooled (engine coolant) by an engine-mounted heat exchanger. Raw water is pumped through the heat exchanger by a belt-driven, positive displacement impeller pump. After the raw water cools the fuel in the gasdenser and cools the engine coolant in the heat exchanger, it mixes with the engine's exhaust gases, cools the exhaust hose, and discharges overboard.

The engine's coolant is circulated by a belt-driven centrifugal-type metal impeller pump mounted on the front of the engine.

The engine's coolant temperature is thermostatically controlled.

The engine's cooling system should be drained, flushed out, and refilled with a fresh mixture of coolant at 750 operating hours or every two years.

⚠ CAUTION: *Proper cooling system maintenance is critical; almost half of engine failures can be traced back to cooling system corrosion.*

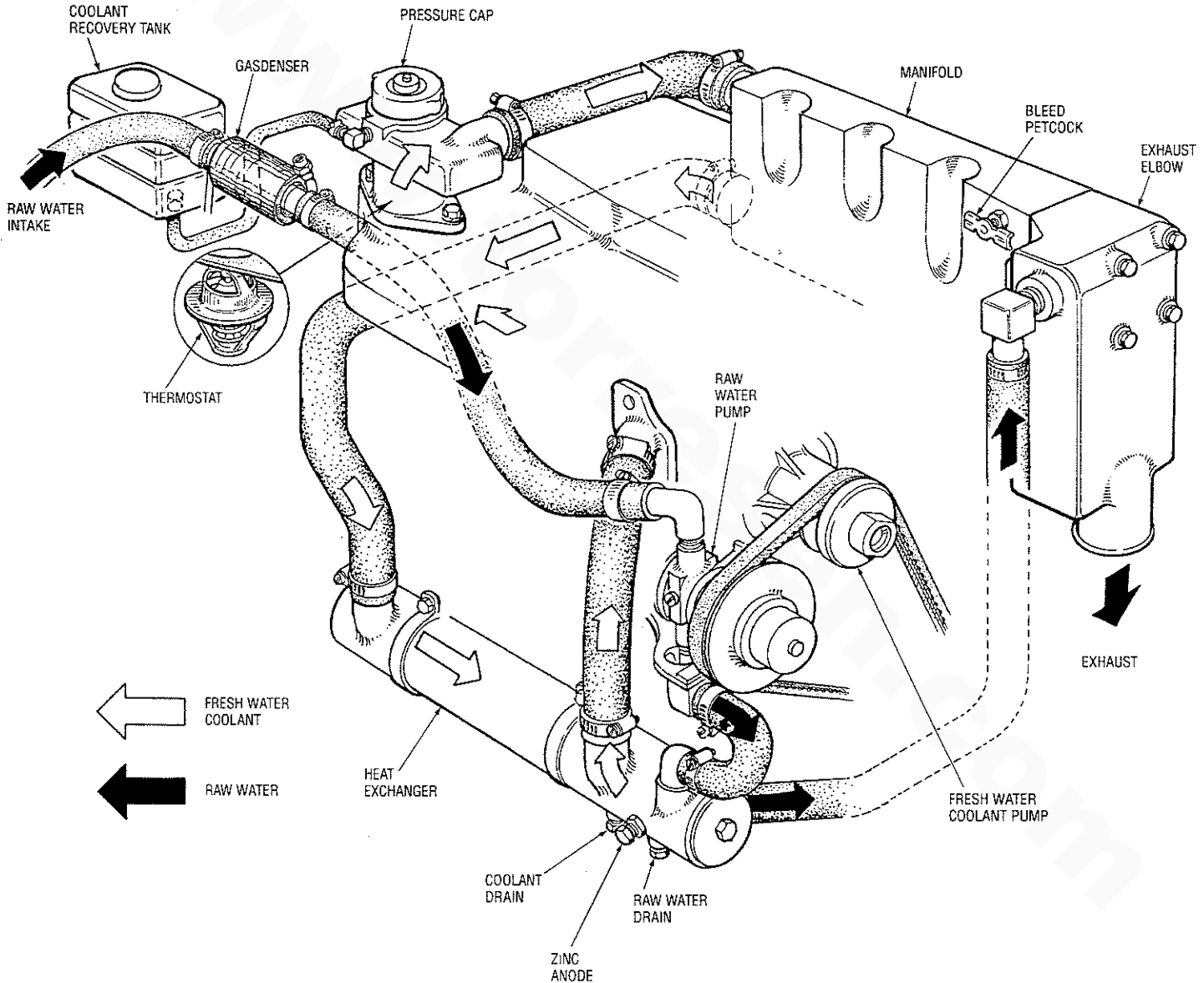

ENGINE COOLING CIRCUIT

THERMOSTAT

A thermostat controls the coolant temperature as the coolant continuously flows through the closed cooling circuit. When the engine is first started the closed thermostat prevents coolant from flowing (some coolant is by-passed through a hole in the thermostat to prevent the exhaust manifold from overheating). As the engine warms up, the thermostat gradually opens. The thermostat is accessible and can be checked, cleaned, or replaced easily. Carry a spare thermostat and gasket.

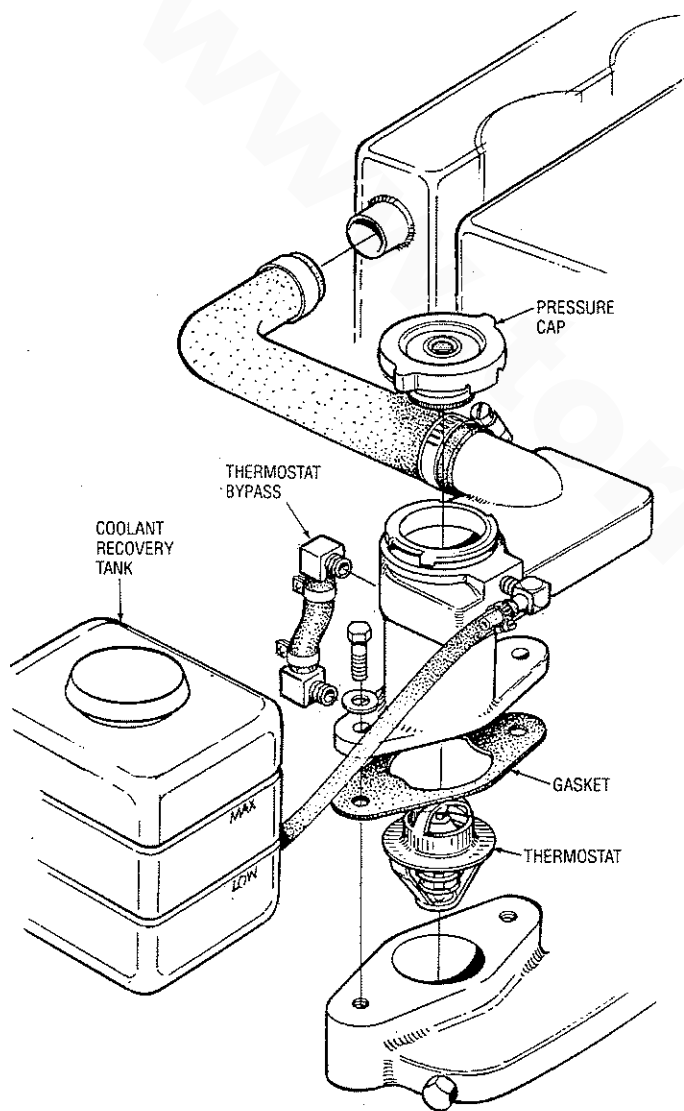

THERMOSTAT TEST

If you suspect a faulty thermostat, place it in a pan of water and bring to a boil. A working thermostat should open about 1/2".

DRAINING THE COOLANT

Remove the manifold pressure cap, loosen the water drain located on the left side of the engine block just under the manifold and loosen the heat exchanger drain plug.

REFILLING THE COOLANT

Slowly pour clean premixed coolant into the manifold.

NOTE: Open the air bleed petcock on the exhaust manifold to help remove air from the system. When a steady flow of coolant appears at the drain, close the water drain plug, fill the system and close the petcock.

Start the engine and bring it to operating temperature. Monitor the coolant in the manifold and add as needed. Fill the manifold to the filler neck and install the pressure cap.

Remove the cap on the coolant recovery tank and fill with coolant halfway between LOW and MAX, and replace the cap.

Run the engine and observe the coolant expansion flow into the recovery tank.

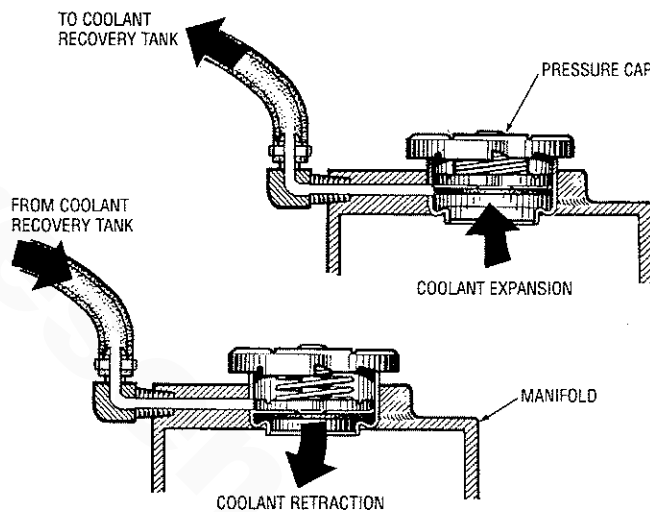

After checking for leaks, stop the engine and allow it to cool. Coolant should drain back into the cooling system as the engine cools down. Add coolant to the recovery tank if needed. Clean up any spilled coolant.

NOTE: Periodically check the condition of the pressure cap. Ensure that the upper and lower rubber seals are in good condition and check that the vacuum valve opens and closes tightly. Carry a spare cap.

WARNING: Always check the coolant level at the coolant recovery tank. If the engine is hot, allow it to cool before checking. **HOT COOLANT** and **STEAM** can cause **INJURY** or **DEATH**! Do not check the coolant at the manifold unless the engine is cool!



ENGINE COOLING CIRCUIT

RAW WATER PUMP

The raw water pump is a self-priming, rotary pump with a non-ferrous housing and a Neoprene impeller. The impeller has flexible blades which wipe against a curved cam plate within the impeller housing, producing the pumping action. *On no account should this pump be run dry.* There should always be a spare impeller and impeller cover gasket aboard (an impeller kit). Raw water pump impeller failures occur when lubricant (raw water) is not present during engine operation. Such failures are not warrantable, and operators are cautioned to make sure raw water flow is present at start-up. The raw water pump should be inspected periodically for broken or torn impeller blades. See *MAINTENANCE SCHEDULE*.

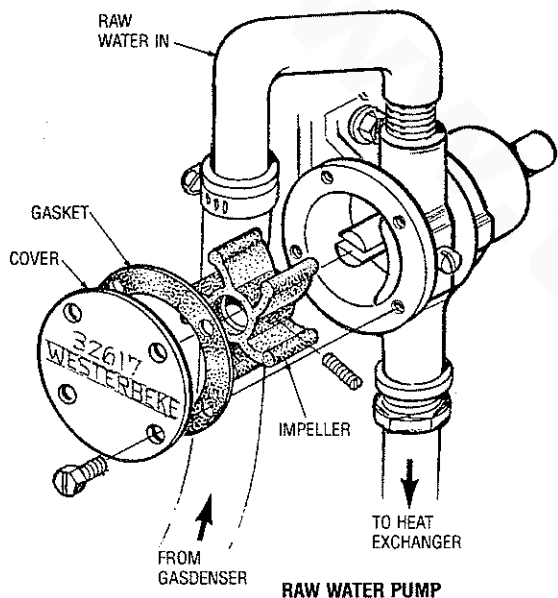

HEAT EXCHANGER

Cool raw water flows through the inner tubes of the heat exchanger. As the engine coolant passes around these tubes the heat of the internal engine is conducted to the raw water which is then pumped into the exhaust system and discharged. The engine coolant (now cooled) flows back through the engine and the circuit repeats itself.

The engine coolant and raw water are independent of each other; this keeps the engine's water passages clean from the harmful deposits found in raw water.

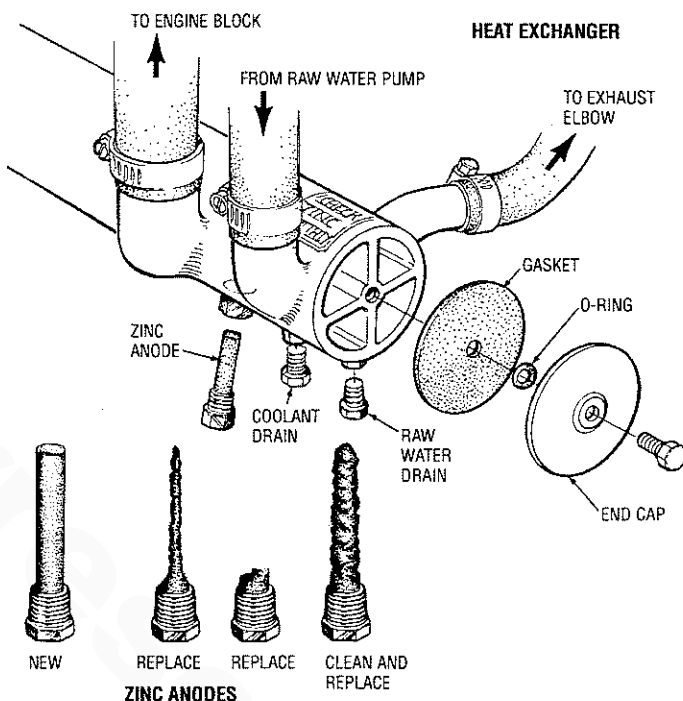

CHANGING THE RAW WATER PUMP IMPELLER

NOTE: Coat the replacement impeller blade tips with petroleum jelly before installing.

CAUTION: The raw water intake valve (seacock) must be closed when servicing any components of the raw water system, and must be re-opened before starting the engine.

A zinc anode (or pencil) is located in the raw water cooling circuit within the heat exchanger. The purpose of the zinc anode is to sacrifice itself to electrolysis action taking place in the raw water cooling circuit, thereby reducing the effects of electrolysis on other components of the system. The condition of the zinc anode should be checked monthly and the anode cleaned or replaced, as required. Spare anodes should be carried onboard. The area in the exchanger where the anode is located should periodically be cleaned of anode debris. Take care not to lose the small O-ring that nestles between the heat exchanger end gasket and the cover.

DRIVE BELT ADJUSTMENT

CAUTION: The drive belt must be properly tensioned for the belt-driven water pumps to function properly.

For the raw water pump/fresh water pump drive belt tension adjustment procedure, see *DRIVE BELTS ADJUSTMENT* under *ENGINE ADJUSTMENTS*.



FUEL SYSTEM

GASOLINE

Use *unleaded* 89 octane or higher gasoline. When fueling, follow U.S. Coast Guard regulations, close off all hatches and companionways to prevent fumes from entering the boat, and ventilate after fueling.

NOTE: The generator compartment should have a gasoline fume detector/alarm properly installed and working.

⚠ WARNING: Shut off the fuel valve at the tank when servicing the fuel system. Take care in catching any fuel that may spill. DO NOT allow any smoking, open flames or other sources of fire near the fuel system when servicing. Ensure proper ventilation exists when servicing the fuel system.

CARBURETOR

The carburetor is a single barrel downdraft type with a solenoid-activated electric choke and electric fuel shutoff solenoid.

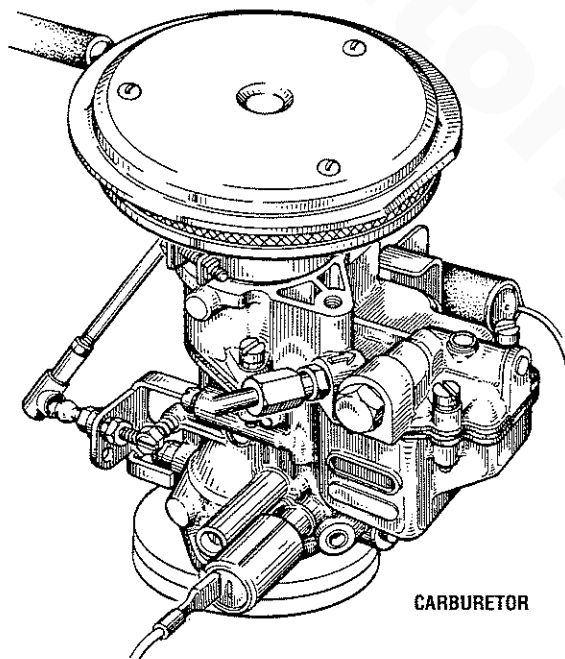

CARBURETOR

GASOLINE/WATER SEPARATOR AND FILTER

A primary fuel filter of the water separating type must be installed between the fuel tank and the engine to remove water and other contaminants from the fuel before they can be carried to the fuel system on the engine.

Most installers include a type of filter/water separator with the generator installation package as they are well aware of the problems that contaminants in the fuel can cause.

These gasoline filters must have *metal* bowls (not “see-through”) to meet U.S. Coast Guard requirements. The metal bowls have drain valves to use when checking for water and impurities.

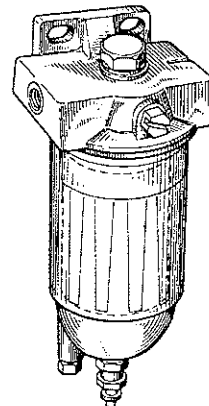

GASOLINE/WATER SEPARATOR

FUEL PUMP

Periodically check the fuel connections to and out of the pump and make sure that no leakage is present and that the fittings are tight and secure. The DC ground connection at one of the pump’s mounting bolts should be clean and well secured by the mounting bolt to ensure proper pump operation.

⚠ WARNING: Fuel leakage at the fuel pump or its connections is a fire hazard and should be corrected. Make sure proper ventilation exists whenever servicing fuel system components.

GASDENSER

The gasdenser consists of a portion of the fuel line that is coiled around the raw water intake line and insulated. It is located between the raw water intake and the raw water pump. The gasdenser cools the fuel to prevent vapor lock.

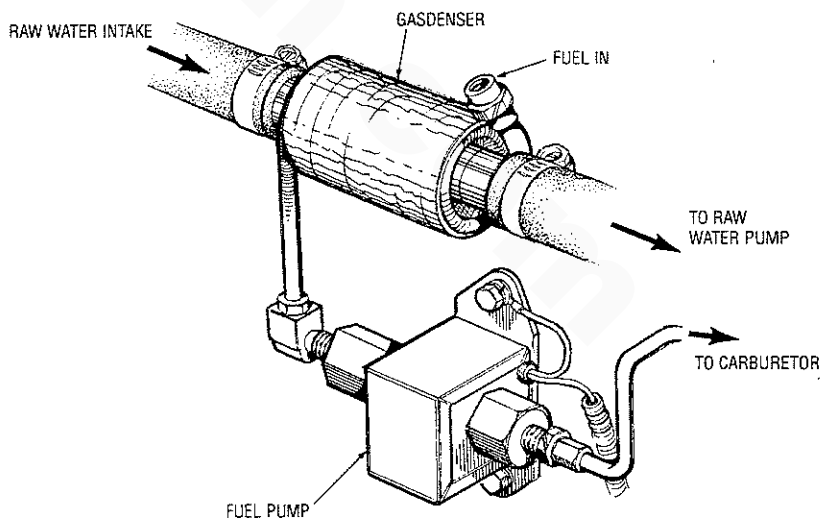

ENGINE LUBRICATING OIL

DESCRIPTION

Use a heavy duty engine oil with an API classification of SJ. Change the engine oil after an initial 50 hours of break-in operation and every 100 hours of operation thereafter. For recommended oil viscosity see the following chart:

| Operating Temperature | Oil Viscosity |
|------------------------|--------------------------|
| Above 68° F (20° C) | SAE 30, 10W-30 or 15W-40 |
| 41° - 68° F (5°-20° C) | SAE 20 or 10W-30 |
| Below 41° F (5° C) | SAE 10W-30 |

CAUTION: Do not allow two or more brands of engine oil to mix. Each brand contains its own additives; additives of different brands could react in the mixture to produce properties harmful to your engine.

CHANGING THE ENGINE OIL

The engine oil should be warm. Remove the oil drain hose from its attachment bracket and lower it into a container and allow the oil to drain, or attach a pump to the end of the drain hose and pump the old oil out. Make sure the oil drain hose is properly secured in its holder after all of the old oil has been drained.

Always observe the old oil as it is removed. A yellow/gray emulsion indicates the presence of water in the oil. Although this condition is rare, it does require prompt attention to prevent serious damage. Call a competent mechanic if water is present in the oil. Raw water present in the oil can be the result of a fault in the exhaust system attached to the engine and/or a siphoning through the raw water cooling circuit into the exhaust, filling it up into the engine.

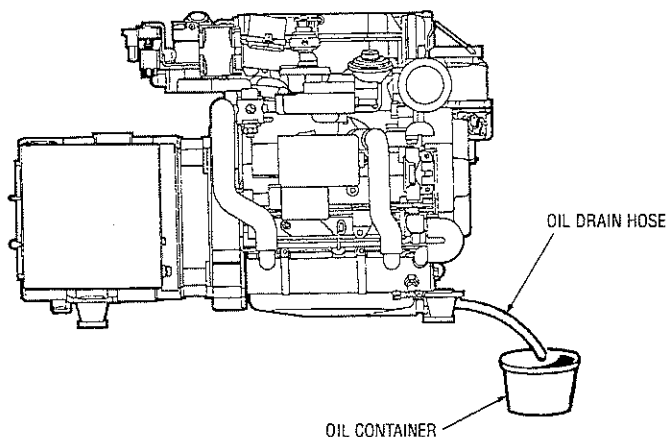

WARNING: Used engine oil contains harmful contaminants. Avoid prolonged skin contact. Clean skin and nails thoroughly using soap and water. Launder or discard clothing or rags containing used oil. Discard used oil properly.

REPLACING THE OIL FILTER

When removing the used oil filter, you may find it helpful to punch a hole in the upper and lower portion of the old filter to drain the oil into a container before removing it. This helps to lessen spillage. An automotive filter wrench should be helpful in removing the old oil filter. Place some paper towels and a plastic bag around the filter when unscrewing it to catch any oil that's in the filter. Inspect the old oil filter as it is removed to make sure that the rubber sealing gasket comes off with the old oil filter. If this rubber sealing gasket remains sealed against the oil filter adapter, gently remove it. When installing the new oil filter element, wipe the filter gasket's sealing surface on the oil filter adapter free of oil and apply a thin coat of clean engine oil to the rubber gasket on the oil filter. Screw the filter onto the threaded oil filter nipple, and tighten the filter firmly by hand.

NOTE: Use genuine WESTERBEKE oil filters. Generic filters are not recommended.

REFILLING THE OIL SUMP

Add fresh oil through the valve cover. After refilling the oil, run the engine for a few moments while checking the engine's oil pressure. Make sure there is no leakage around the new oil filter or from the oil drain system, and then stop the engine. Then check the quantity of oil with the lube oil dipstick. Fill to, but not over, the FULL mark on the dipstick.

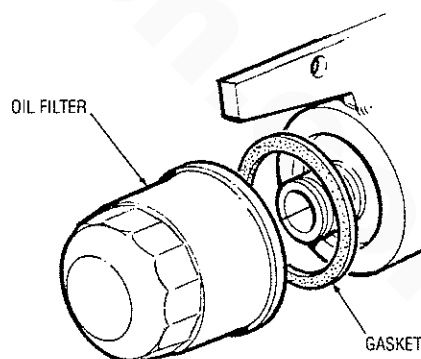

REMOTE OIL FILTER (OPTIONAL)

INSTALLATION

This popular accessory is used to relocate the engine's oil filter from the engine to a more convenient location such as an engine room bulkhead.

NOTE: Refer to *REPLACING THE OIL FILTER* for instructions on removing the oil filter.

To install, simply remove the engine oil filter and thread on WESTERBEKE's remote oil filter kit as shown. Always install this kit with the oil filter facing down as illustrated.

Contact your WESTERBEKE dealer for more information.

NOTE: Westerbeke is not responsible for engine failure due to incorrect installation of the Remote Oil Filter.

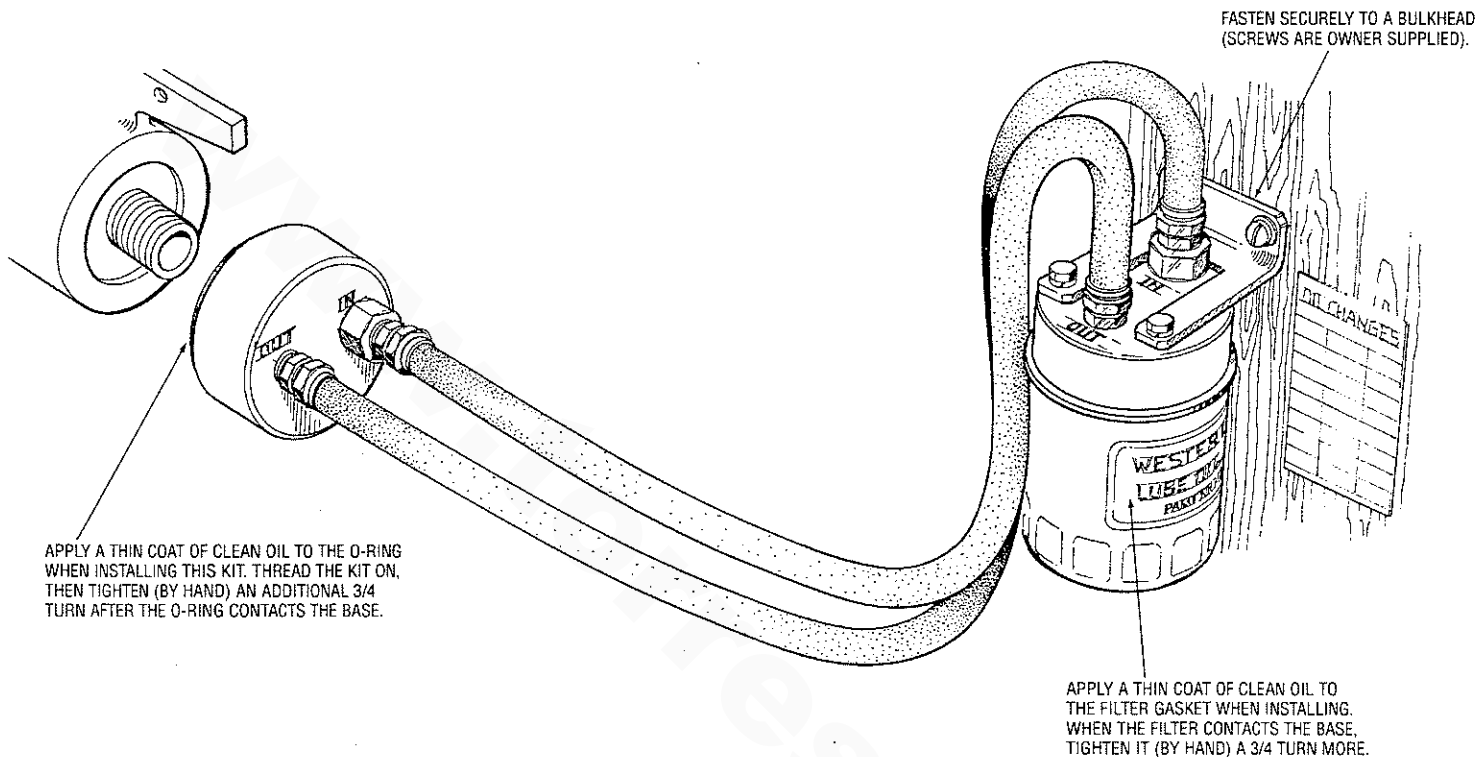

DC ELECTRICAL SYSTEM

12-VOLT DC CONTROL CIRCUIT

The DC Circuit on the BCGTC functions to start, operate and stop the generator's engine. The circuit is best understood by reviewing the DC Wiring Diagram and Wiring Schematic. The engine's DC wiring is designed with three simple basic circuits: start, run and stop.

The engine has a 12 volt DC electrical control circuit that is shown on the Wiring Diagrams. Refer to these diagrams when troubleshooting or when servicing the DC electrical system or the engine.

BATTERIES

CAUTION: To avoid damage to the battery charging circuit, never shut off the engine battery switch while the engine is running. Shut off the engine battery switch, however, to avoid electrical shorts when working on the engine's electrical circuit.

Specifications

The minimum recommended capacity of the battery used in the engine's 12-volt DC control circuit is 300 CCA.

Battery Maintenance

Review the manufacturer's recommendations and then establish a systematic maintenance schedule for your engine's starting batteries and house batteries.

- Monitor your voltmeter for proper charging during engine operation.
- Check the electrolyte level and specific gravity with a hydrometer.
- Use only distilled water to bring electrolytes to a proper level.
- Make certain that battery cable connections are clean and tight to the battery posts (and to your engine).
- Keep your batteries clean and free of corrosion.

WARNING: Sulfuric acid in lead batteries can cause severe burns on skin and damage clothing. Wear protective gear.

BATTERY CHARGING

The generator supplies a continuous 17 amp charge from its battery charger to the starting battery.

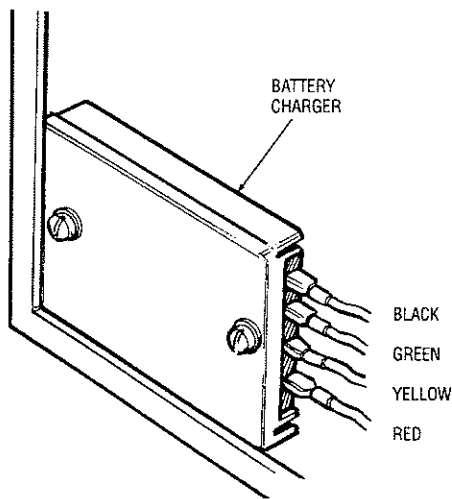

COMPONENT TESTING

All DC voltage measurements are made to the engine battery negative ground point unless specified otherwise. In making test measurements, make sure that a good ground for the meter is established, preferably the point where the negative battery is connected to the engine. Battery positive voltage is indicated as B+ and should measure no less than 11.5 volts.

AC voltage measurements should be made with a true RMS AC meter to insure measurement accuracy.

Relay. The relays used in the control system have coils which are polarized by the fact that they have internal free wheeling suppression diodes across them. Relay coil terminal 86 must be maintained (+), terminal 85(-). The relay coil is rated 12V DC, and the coil resistance is typically 85 ohms. With B+ on terminal 86, direct grounding of terminal 85 is permissible for testing purposes.

DC ELECTRICAL SYSTEM

WIRING DIAGRAM #42834

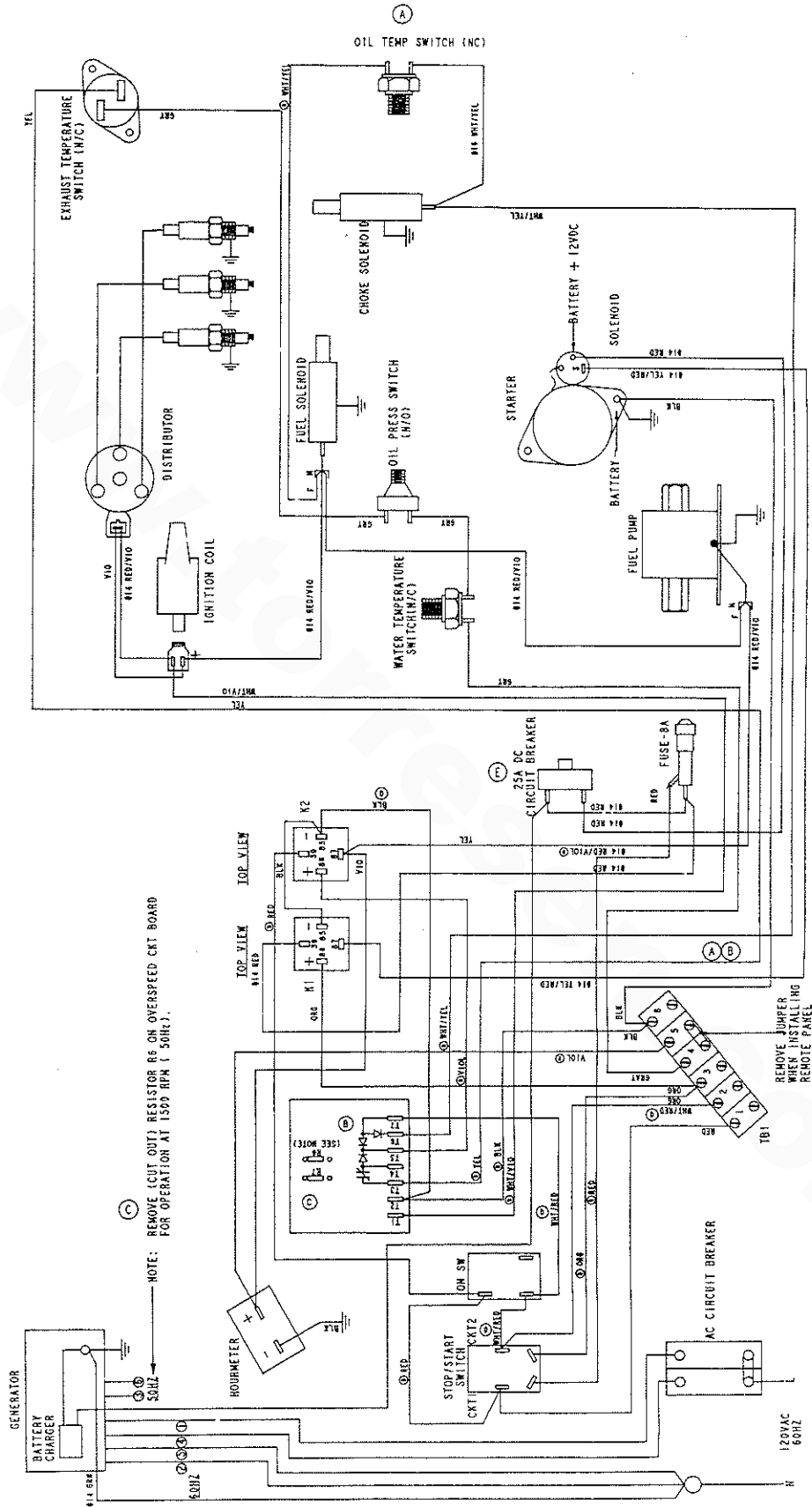

Rev. E 3/28/98

DC ELECTRICAL SYSTEM

WIRING SCHEMATIC #42834

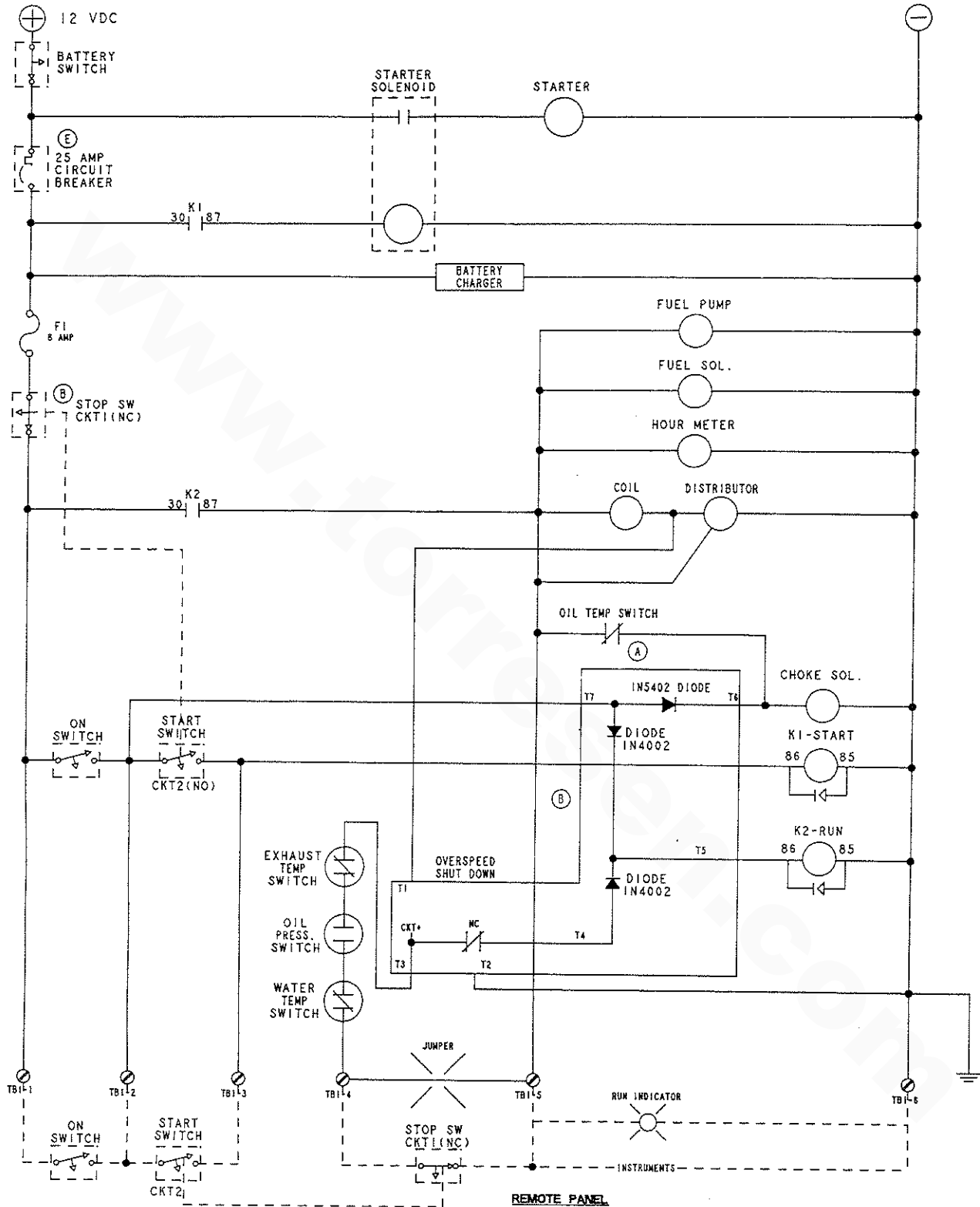

- NOTES:
1. ALL WIRE #16AWG(10SDEG C 600V-ALPHA# 1858/19-MIL-W-16878D TYPE B) UNLESS SPECIFIED OTHERWISE.
 2. WARNING - RELAYS K1, K2 HAVE INTERNAL DIODES ACROSS THEIR COILS, POLARITY AS INDICATED MUST BE MAINTAINED TO AVOID DAMAGE TO THE RELAYS.



Rev. E 3/28/98

DC ELECTRICAL SYSTEM

WIRING DIAGRAM #42857

REMOTE PANEL(S)

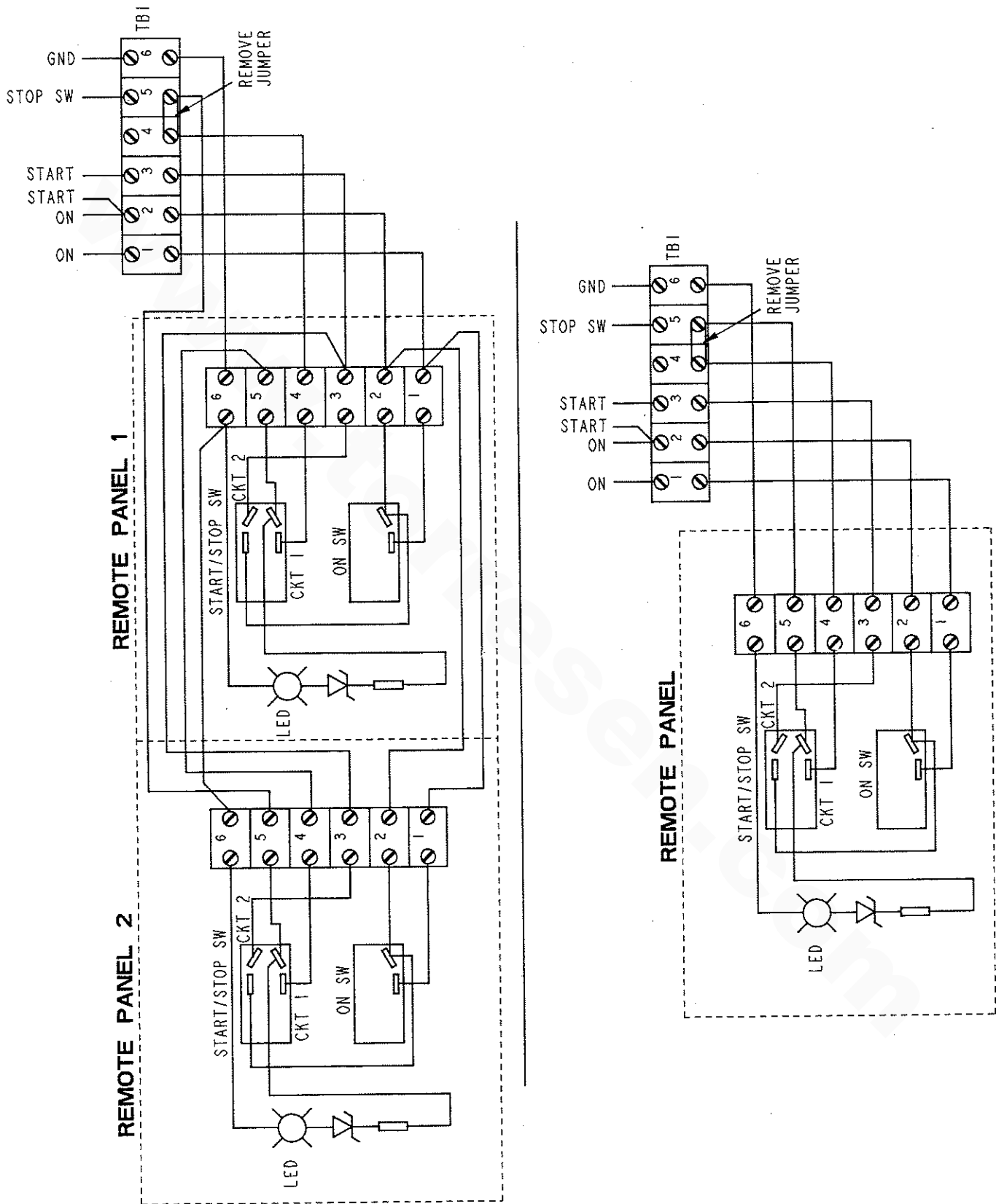

ENGINE ADJUSTMENTS

NOTE: WESTERBEKE recommends that the following engine adjustments be performed by a competent engine mechanic. The information below is provided to assist the mechanic.

ENGINE SPEED (HERTZ) ADJUSTMENT

Governor

The belt-driven, mechanically operated governor maintains the engine's rpm under various load conditions. Engine speed determines the hertz and voltage output of the generator.

Governor Adjustments

Operate the generator to bring the unit up to operating temperature before adjusting the governor.

NOTE: If the governor is severely out of adjustment, manually adjust the linkage at no-load to obtain a safe output voltage before proceeding with the adjustment.

There are three adjusting points on the governor (see illustration).

- 1. Increase/Decrease Speed Adjustment.** This adjusting bolt sets the no-load speed of the engine. (The linkage arm between the governor arm and throttle lever should be adjusted to hold the throttle full open when the engine is not running.) Make sure this linkage moves freely and that the ball joint connectors are properly lubricated. Use graphite lube for this purpose. Disconnect the ball joint and apply graphite lube to the inside of the joint.
- 2. Hunting/Regulation Adjustment.** If the variation in engine speed between no-load and full-load is too great, adjust this eye bolt to draw the spring closer to the lever hub. The increase/decrease speed bolt may need to be adjusted as well.

If the governor surges under load, adjust this eye bolt to move the spring away from the lever hub (check speed adjustment).

- 3. Bumper Screw Adjustment.** This screw is used to remove a no-load surge ONLY. NEVER turn the bumper screw into the governor so far that it increases the no-load speed.

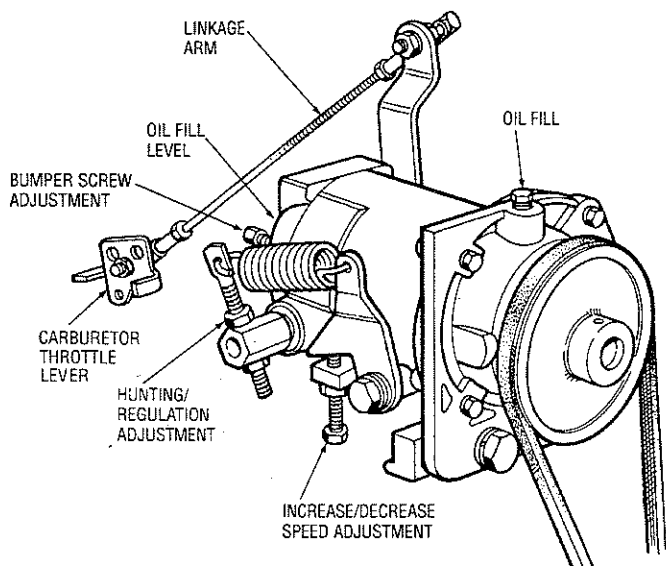

GOVERNOR

Governor Maintenance

1. Periodically lubricate the linkage arm attaching points at the governor arm and throttle lever. Use a graphite lubricant or equivalent.

NOTE: Free movement of this linkage arm is important for proper governor/throttle operation.

2. Governor oil capacity – 3 ounces 10/30 engine oil.

NOTE: Do not overfill the governor.

3. Change the governor oil every 250 hours of operation.

To change the oil, remove the governor from the engine, remove the oil fill and the fill level plug, and drain all the oil. Reinstall on the engine and fill with 3 ounces of 10/30 engine oil. Replace the plugs.

4. Periodically adjust the governor belt tension (see *DRIVE BELTS ADJUSTMENT*). Since belts stretch slightly, this stretching will, to some degree, affect the governor's action.

TORQUING THE CYLINDER HEAD BOLTS

After the initial break-in period (approximately 50 hours), the cylinder head bolts should be re-torqued.

Tighten the cylinder head bolts according to the sequence shown. Make sure the engine is cold when this is done, and loosen one head bolt one-half turn and then tighten it between 43–51 lb-ft (60–70 Nm). Then proceed to the next head bolt in the sequence. Tighten the RS (rocker cover stud) securely.

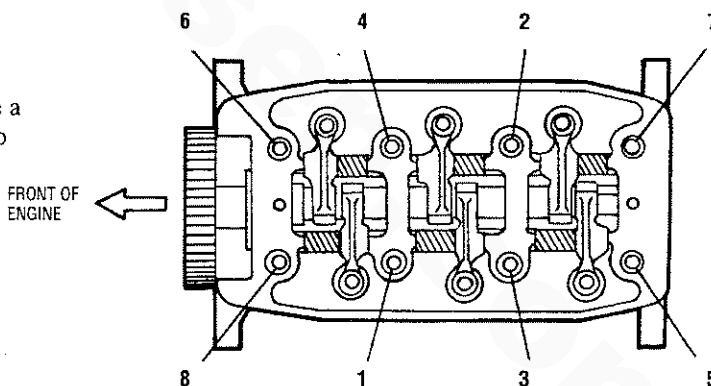

ENGINE ADJUSTMENTS

NOTE: WESTERBEKE recommends that the following engine adjustments be performed by a competent engine mechanic. The information below is provided to assist the mechanic.

VALVE CLEARANCE ADJUSTMENT

NOTE: Retorque the cylinder head bolts before adjusting the engine's valves (see *TORQUING THE CYLINDER HEAD BOLTS*).

1. Remove the rocker cover and gasket.
2. Adjust the intake and exhaust valves in the firing order of the engine (1-3-2), as follows:

Rotate the crankshaft in its normal direction of rotation, placing the No. 1 piston at the TDC (Top Dead Center) of its compression stroke with the intake and exhaust valves completely closed. Then adjust the intake and exhaust valve clearances for cylinder No. 1.

Valve clearances:

- Intake valves – 0.20 mm (.008 in)
- Exhaust valves – 0.30 mm (.012 in)

Repeat the above procedure to adjust the intake and exhaust valves for No. 3 cylinder, then repeat this procedure once more to adjust the intake and exhaust valves for No. 2 cylinder.

3. Replace the rocker cover along with a new rocker cover gasket.

Rocker cover torque: 2.9–5.1 lb-ft (0.4–0.7 kg-m)

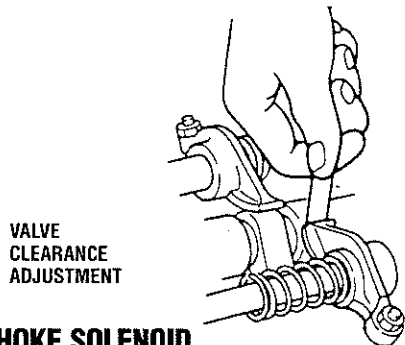

CHOKE SOLENOID

The choke solenoid is a 12 volt DC operated unit that functions to close the choke plate in the carburetor when the ON switch is depressed during engine start-up.

The choke solenoid de-energizes once the engine starts and the ON switch is released. Some unstable running may be present when the engine starts cold but should smooth out as the engine reaches operating temperature.

Keep this solenoid dry and periodically lubricate the linkage between the solenoid and the choke lever.

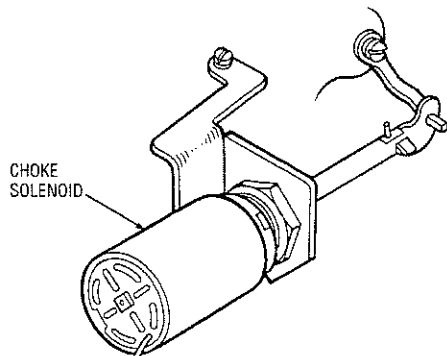

IGNITION TIMING

1. Attach a timing light to the #1 spark plug and mark the front timing pointer to indicate 18°. Locate the timing mark on the crankshaft pulley and mark it with white chalk or a crayon.
2. Start the engine and warm it up to its normal operating temperature. Make sure the generator is operating *without a load on it*.
3. Using the timing light, align the timing mark in the front crankshaft pulley so it is just slightly before the first timing pointer. Do this by loosening and slowly rotating the distributor body. Use the following timing specifications:
Timing Specifications: 18° ± .5° BTDC at 3600 rpm (*no load on generator*)

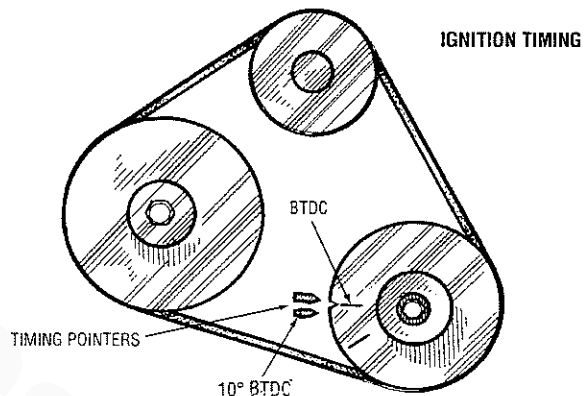

SPARK PLUGS

The spark plugs should be cleaned and regapped after the first 50 hour break-in period, then inspected every 250 hours thereafter and replaced as needed.

WARNING: Do not remove the spark plugs while the engine is hot. Allow the engine to cool before removing them.

Spark plug gap: 0.028 – 0.031 in. (0.7 – 0.8 mm).

Spark plug torque: 10.8 – 15.2 lb-ft (1.5 – 2.1 kg-m).

NOTE: Loc-tite Anti-Seize applied to the threaded portion of the spark plugs will retard corrosion, making future removal of the spark plugs easier.

SPARK PLUG INSPECTION

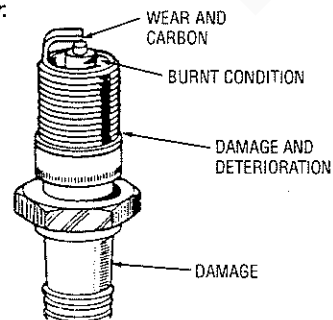

ENGINE ADJUSTMENTS

NOTE: WESTERBEKE recommends that the following engine adjustments be performed by a competent engine mechanic. The information below is provided to assist the mechanic.

CARBURETOR ADJUSTMENT

Basic Jet Adjustment is performed with the generator operating. Screw the jet slowly in until it seats, then back it out 1-1/2 to 2 turns.

NOTE: An idle mixture jet adjusted too far off its seat can induce a sooty exhaust discharge at engine start-up and shutdown.

NOTE: At idle speed, oil pressure will be lower than the rating of the oil pressure switch. Jump this switch to prevent engine shutdown at idle speed.

Run Mixture Jet. This mixture jet is presized at the factory and is not adjustable. The idle mixture jet adjustment can be made in the 3600 rpm range to improve engine performance.

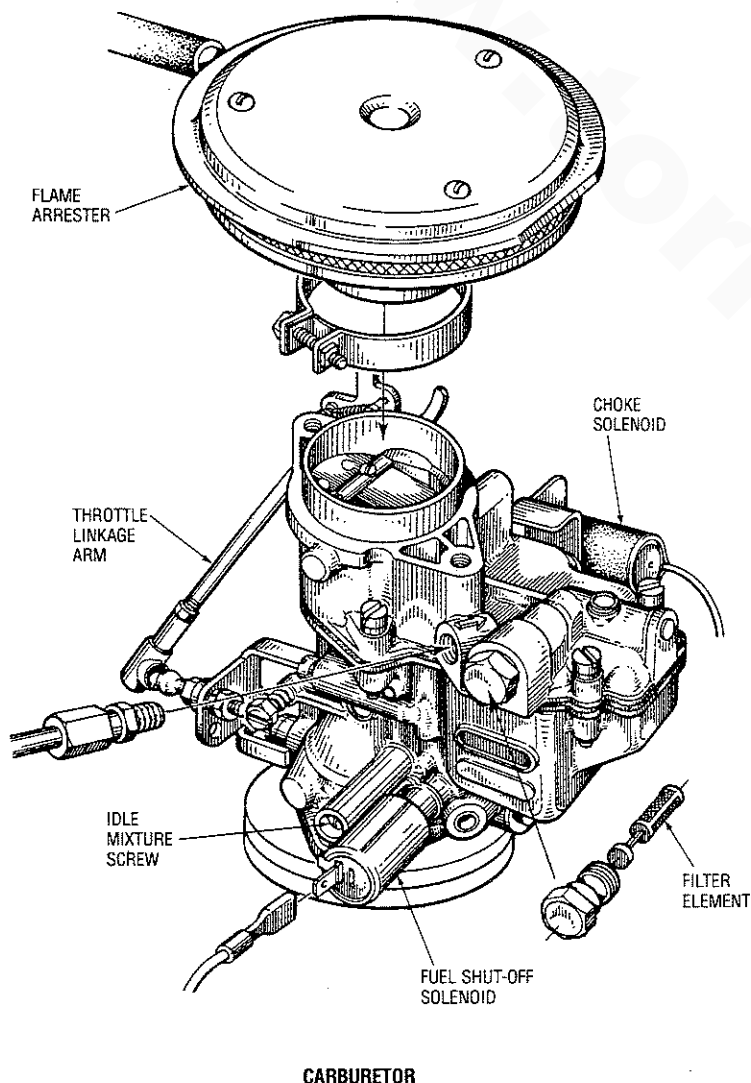

DRIVE BELTS ADJUSTMENT

The drive belts must be properly tensioned. Excessive drive belt tension can cause rapid wear of the belt and reduce the service life of the fresh water pump's bearing. A slack belt or the presence of oil on the belt can cause belt slipping, resulting in high operating temperatures.

The BCGTC generator has two drive belts, one for the governor and one for the raw water pump/fresh water pump. The tension adjustment procedure for both belts is as follows:

1. Remove the belt guard.
2. To adjust the governor drive belt, loosen the two governor mounting bolts.

To adjust the raw water pump/fresh water pump drive belt, loosen the two raw water pump mounting bolts.

3. With the belt(s) loose, inspect for wear, cracks and frayed edges, and replace if necessary.
4. To loosen or tighten the governor drive belt, slide the governor in or out as required, then retighten its mounting bolts.

To loosen or tighten the raw water pump/fresh water pump drive belt, slide the raw water pump in or out as required, then retighten its mounting bolts.

5. The drive belts are properly adjusted if they can be deflected no less than 3/8 inch (10mm) and no more than 1/2 inch (12mm) as the belt is depressed with the thumb at the midpoint between the two pulleys on the longest span of the belt.

NOTE: Maintain a 22 lb pressure to the belt's outer face for proper belt operation. Spare belts should always be carried on board.

WARNING: Never attempt to check or adjust a drive belt's tension while the engine is in operation.

6. Operate the generator for about 5 minutes, then shut down the generator and recheck the belt(s) tension.
7. Replace the belt guard.

ENGINE ADJUSTMENTS

NOTE: WESTERBEKE recommends that the following engine adjustments be performed by a competent engine mechanic. The information below is provided to assist the mechanic.

TIMING BELT INSPECTION AND REPLACEMENT

Timing Belt Removal

CAUTION: Water or oil on the timing belt severely reduces the service life of the belt. Keep the timing belt sprocket and tensioner free of oil and grease. These parts should never be cleaned. Replace if seriously contaminated with dirt or oil. If oil is evident on these parts, check the front case, oil pump oil seals, and camshaft oil seals for a possible oil leak.

1. Turn the crankshaft clockwise to align the timing mark on the camshaft sprocket and timing belt rear cover.

NOTE: always turn the crankshaft clockwise.

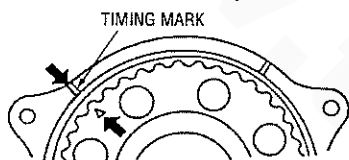

2. Remove the plug on the left surface of the cylinder block and insert a rod with a diameter of 8mm (0.31 in.) to lock the counterbalance shaft.

NOTE: Be sure to use an inserting rod with a diameter of 8mm (0.31 in.).

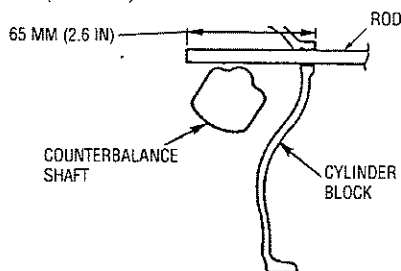

3. Loosen the timing belt tensioner nut.
4. Move the timing belt tensioner toward the water pump, and temporarily tighten the nut to hold the tensioner in that position.

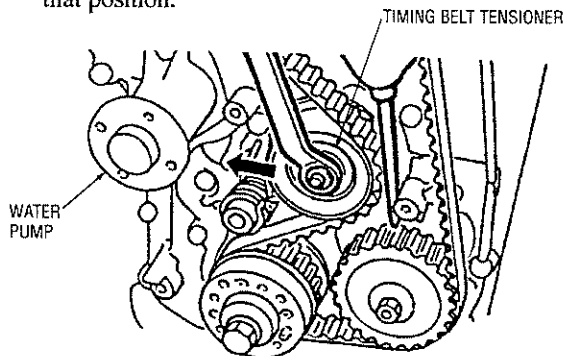

5. Remove the timing belt.

NOTE: If the timing belt is to be reused, draw an arrow on the belt back to indicate the direction of rotation (clockwise).

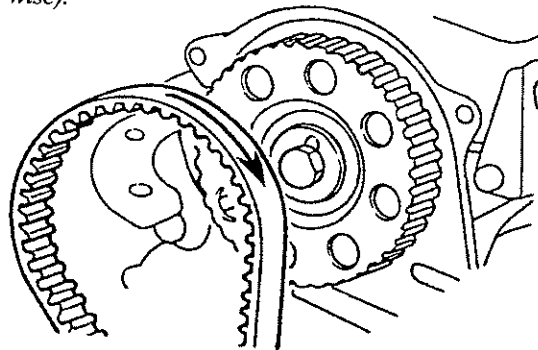

Camshaft Sprocket Removal

1. Remove the bolt without turning the camshaft.

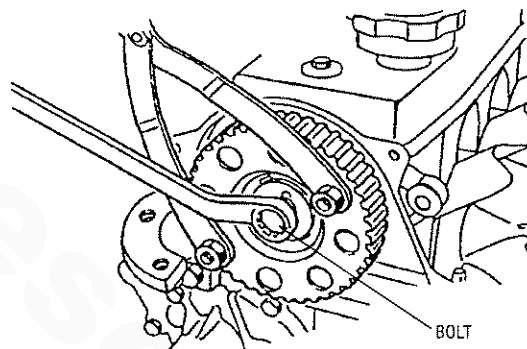

Oil Pump Sprocket Flange Nut Removal.

1. Remove the plug from the left side of the cylinder block.
2. Insert an 8 mm (0.31 in.) diameter round bar to lock the counterbalance shaft.
3. Remove the nut.

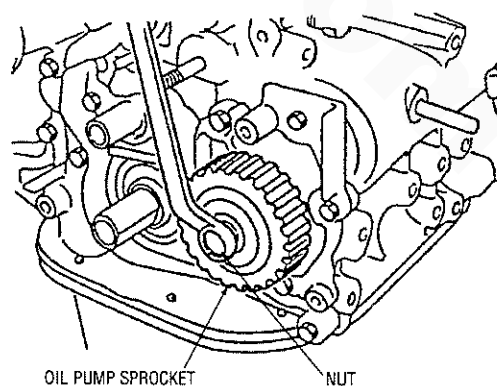

ENGINE ADJUSTMENTS

NOTE: WESTERBEKE recommends that the following engine adjustments be performed by a competent engine mechanic. The information below is provided to assist the mechanic.

Crankshaft Bolt Removal

1. Lock the crankshaft in position.

NOTE: Do not turn the crankshaft.

2. Remove the crankshaft bolt.

Timing Belt Inspection

Replace the belt if any of the following conditions exist:

1. Hardening of back rubber-back side is glossy, without resilience, and leaves no indent when pressed with fingernail.
2. Cracks on rubber back.
3. Cracks or peeling of canvas.
4. Cracks on tooth bottom.
5. Cracks on belt.
6. Abnormal wear of belt sides. The sides are normal if they are sharp as if cut by a knife.
7. Abnormal wear on teeth.
8. Tooth missing and canvas fiber exposed.

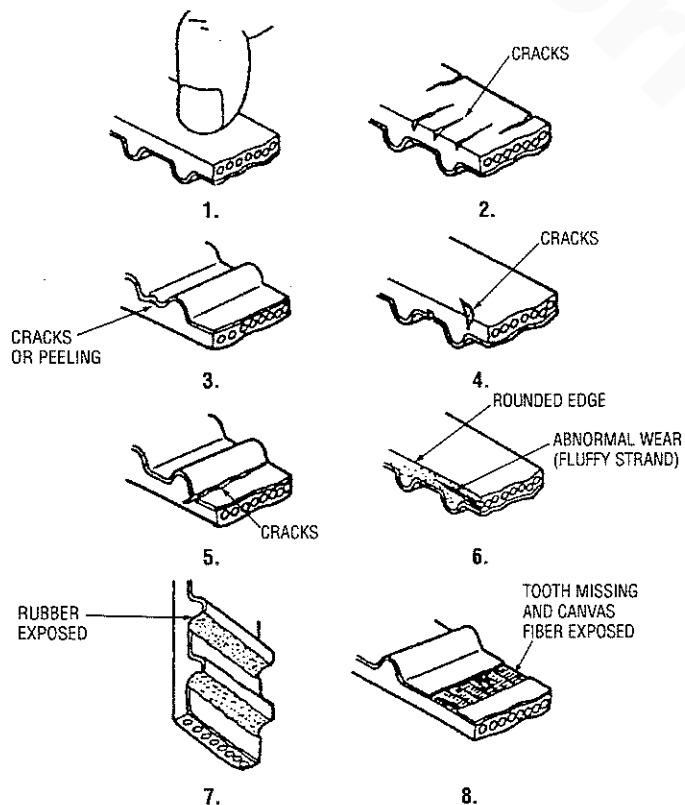

Tensioner Inspection

1. Replace the tensioner if the pulley binds, rattles or is noisy when turned.

Flange Installation

1. Mount the flange so that its side shown by the heavy arrow in the illustration faces toward the sprocket.

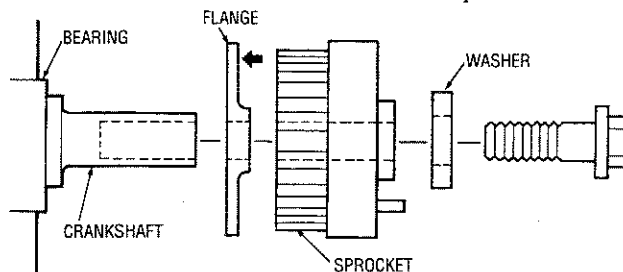

Crankshaft Bolt Installation

1. Lock the crankshaft.

NOTE: Do not turn the crankshaft.

2. Tighten the crankshaft bolt to the specified torque.

Oil Pump Sprocket Flange Nut Installation

1. Insert a round bar into the plug hole in the left side of the cylinder block to keep the counterbalance shaft from turning.
2. Install the oil pump sprocket.
3. Tighten the nut to the specified torque.

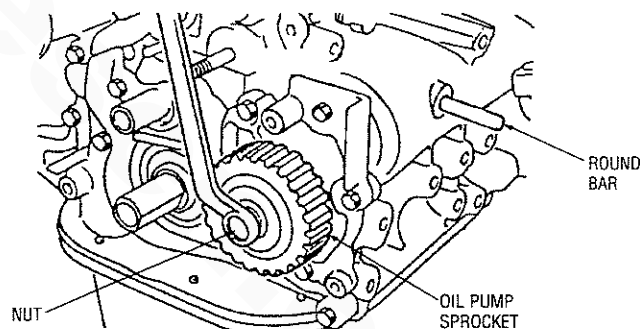

Camshaft Sprocket Bolt Installation

1. Tighten the bolt to the specified torque.

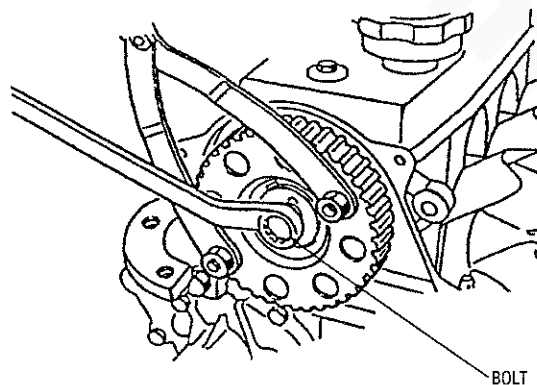

ENGINE ADJUSTMENTS

NOTE: WESTERBEKE recommends that the following engine adjustments be performed by a competent engine mechanic. The information below is provided to assist the mechanic.

Tensioner Spring/Timing Tensioner Installation

1. Install the tensioner spring and timing belt tensioner.
2. Hook the tensioner spring onto the bend of the timing belt tensioner bracket and the stopper pin on the cylinder block.
3. Move the timing belt tensioner as close as possible to the water pump; temporarily tighten the tensioner nut.

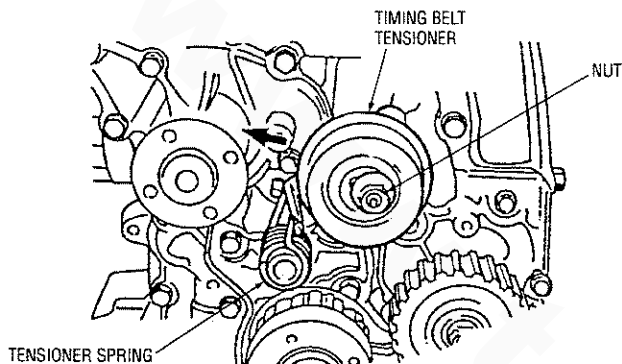

Timing Belt Installation

1. Align the triangular marking on the camshaft sprocket with a marking on the timing belt rear cover.
2. Align the notch in the crankshaft sprocket flange with the marking on the front case.
3. Align the triangular marking on the oil pump sprocket with the marking on the front case, and then insert a 65 mm (2.56 in.) or longer, 8 mm (0.31 in.) diameter round bar into the plug hole in the left side of the cylinder block.

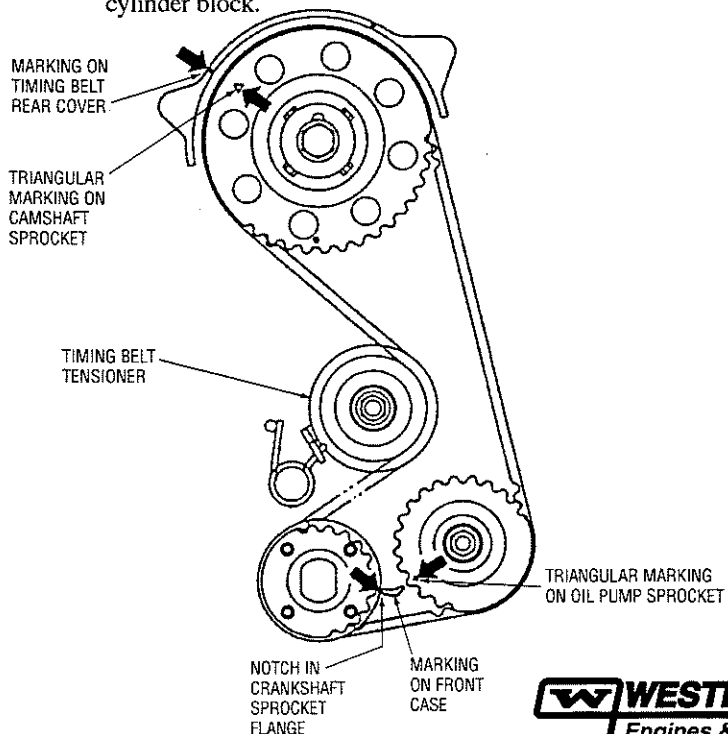

At this time, check that the moveable range of teeth on the oil pump sprocket is according to specifications.

Standard value: 4 to 5 teeth in forward direction
1 to 2 teeth in reverse direction

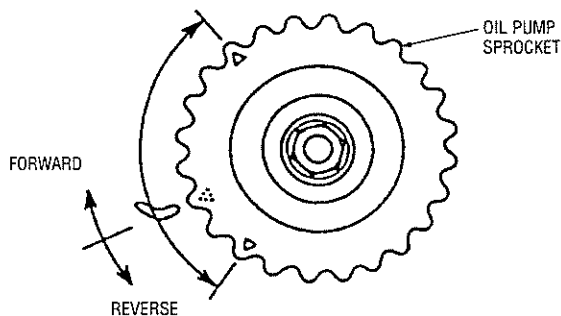

4. If the movable range of the oil pump sprocket exceeds the specified range, correct as follows:
 - a. Pull out the round bar from the plug hole in the left side of the cylinder block.
 - b. Turn the oil pump sprocket one turn at a time until the round bar can again be inserted.
 - c. Check that the movable range of the oil pump sprocket is in the specified value.
5. Set the timing belt over the crankshaft sprocket and then over the oil pump sprocket and camshaft sprocket, in that order.

NOTE: Ensure that the tension side of the timing belt is not slack. Keep the round bar inserted until the timing belt has been placed. After this step, be sure to remove the round bar.

6. Apply counterclockwise force to the camshaft sprocket to make the belt taut on the tension side, and make sure that all timing marks are lined up.

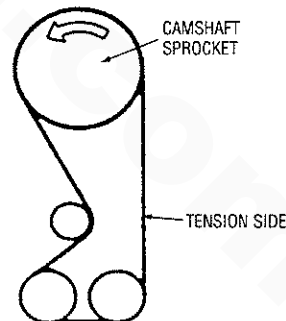

7. Loosen the temporarily tightened tensioner nut on the water pump side 1 or 2 turns, and tension the belt making use of spring force.

ENGINE ADJUSTMENTS

NOTE: WESTERBEKE recommends that the following engine adjustments be performed by a competent engine mechanic. The information below is provided to assist the mechanic.

- Turn the crankshaft *clockwise* by nine camshaft sprocket teeth (81°) to align the timing mark on the camshaft sprocket with the tensioner set mark on the timing belt rear cover.

CAUTION: This operation is performed to give a proper tension to the timing belt, so do **NOT** turn the crankshaft counterclockwise and push the belt to check the tension.

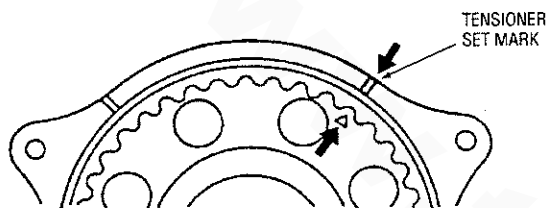

- Make sure that the timing belt teeth are engaged with the camshaft sprocket teeth along the portion of the sprocket shown by the curved arrow in the illustration below. Then tighten the tensioner nut.
- Pull the timing belt in the center of the tension side toward the sealing gasket line for the belt cover, as illustrated. Make sure that the clearance between the back of the belt and the sealing line is the standard value.

Standard Value: 12mm (0.47in.)

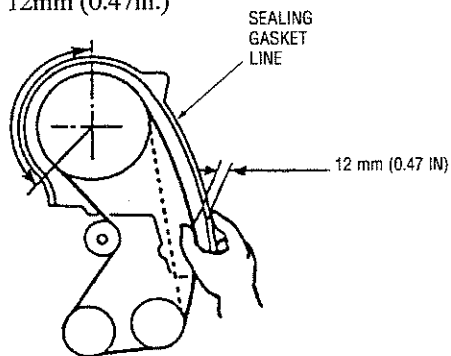

- Pull out a rod from the plug hole on the left surface of the cylinder block and apply the specified sealant. Then tighten the plug to the specified torque.
Specified sealant value: 3M ATD Part No. 8660 or equivalent
Tightening torque: 15-22 Nm (11-16 ft.lbs.)

ENGINE TROUBLESHOOTING

The following troubleshooting tables are based upon certain engine problem indicators and the most likely causes of the problems.

When troubleshooting indicates an electrical problem, see the DC Electrical System Wiring Diagram and Schematic, as they may reveal other possible causes of problems not listed below.

| PROBLEM | PROBABLE CAUSE |
|-----------------------------------|--|
| Engine does not crank. | <ol style="list-style-type: none"> 1. Voltage drop at starter solenoid terminal. 2. Engine 20A circuit breaker has tripped. 3. Battery is low or dead. 4. Loose battery connections. 5. Faulty wire connection. 6. Faulty start switch. 7. Faulty start relay (K1). 8. Faulty starter solenoid. 9. Raw water filled cylinders. |
| Engine cranks but fails to start. | <ol style="list-style-type: none"> 1. Out of fuel. 2. Engine is flooded. <ol style="list-style-type: none"> a. Carburetor float needle valve open or damaged. Clean or replace the needle valve. b. Float in carburetor is leaking. Repair or replace float. c. Float chamber gasket damaged or securing screws are loose. Replace gasket and/or tighten screws. 3. Fuel pump inoperative. 4. Worn or faulty spark plugs. 5. High tension wires grounding (wet system). 6. Faulty ignition coil. 7. Faulty distributor. 8. Faulty wire connection. 9. Faulty overspeed circuit board. Replace. 10. Faulty run relay (K2). 11. Timing belt. 12. No engine compression. 13. Faulty idle adjustment. |

| PROBLEM | PROBABLE CAUSE |
|--|--|
| Engine starts, runs and then shuts down. | <ol style="list-style-type: none"> 1. Faulty shutdown switch, (oil pressure, water or exhaust temperature). 2. High engine water or exhaust temperature. 3. Dirty fuel/water separator filter. 4. Mechanical check valve at the fuel supply faulty. 5. Low oil level in sump. 6. Faulty fuel pump. 7. Faulty engine temperature sensor. |
| Engine starts, runs but does not come up to speed. | <ol style="list-style-type: none"> 1. Fuel line restriction. 2. Mechanical check valve at the fuel supply is faulty. 3. Throttle plate binding. 4. Faulty fuel pump. 5. Faulty wire connection. 6. Faulty engine temperature sensor. 7. AC generator overload. 8. High exhaust pressure. |
| Engine hunts. | <ol style="list-style-type: none"> 1. Low battery voltage. 2. Generator is overloaded. 3. Cracked distributor cap. 4. Faulty high tension wires. 5. Faulty fuel pump. 6. High exhaust back-pressure. 7. Valves are out of adjustment. |



ENGINE TROUBLESHOOTING

| PROBLEM | PROBABLE CAUSE |
|-------------------|---|
| Engine misfires. | <ol style="list-style-type: none"> 1. Poor quality fuel. 2. Incorrect timing. 3. Dirty flame arrester. 4. Cracked distributor cap. 5. Faulty ignition wires. 6. Spark plugs are worn. 7. High exhaust back-pressure. 8. Valve clearances are incorrect. |
| Engine backfires. | <ol style="list-style-type: none"> 1. Spark plug wires are connected wrong. 2. Incorrect timing. 3. Engine is flooded. See <i>Engine is flooded under Engine cranks but fails to start.</i> 4. Dirty flame arrester. 5. Cracked distributor cap. 6. High exhaust back-pressure. |
| Engine overheats. | <ol style="list-style-type: none"> 1. Coolant loss. Pressure test cooling system. 2. Faulty raw water pump impeller. 3. Belts are loose or broken. 4. Raw water pump worn. 5. Faulty thermostat. |
| Low oil pressure. | <ol style="list-style-type: none"> 1. Low oil level. 2. Wrong SAE type oil in the engine. 3. Wrong type oil filter. 4. Relief valve is stuck. 5. Faulty oil pump. 6. Faulty engine bearings. |

| PROBLEM | PROBABLE CAUSE |
|--|--|
| High oil pressure. | <ol style="list-style-type: none"> 1. Dirty oil or wrong SAE type oil in the engine. 2. Relief valve is stuck. |
| No DC charge to the starting battery. | <ol style="list-style-type: none"> 1. Faulty connections to battery voltage regulator. 2. Faulty battery voltage regulator. 3. Faulty bridge rectifier. 4. Faulty generator charger windings. |
| Blue exhaust smoke discharge from the engine. | <ol style="list-style-type: none"> 1. Lube oil is diluted. 2. High lube oil level. 3. Crankcase breather hose is clogged. 4. Valves are worn or adjusted incorrectly. 5. Piston rings are worn or unseated. |
| Black exhaust smoke discharge from the engine. | <ol style="list-style-type: none"> 1. Dirty flame arrester. 2. Faulty carburetor. |
| Poor performance at generator speed. | <ol style="list-style-type: none"> 1. Main jet clogged. Remove and clean. 2. Carburetor inlet filter clogged. Remove and clean. 3. Fuel pump clogged. Remove and replace. 4. Air intake filter screen dirty. Remove and clean. |

GENERATOR INFORMATION

USE OF ELECTRIC MOTORS

The power required to start an electric motor is considerably more than is required to keep it running after it is started. Some motors require much more current to start than others. Split-phase (AC) motors require more current to start, under similar circumstances, than other types. They are commonly used on easy-starting loads, such as washing machines, or where loads are applied after the motor is started, such as small power tools. Because they require 5 to 7 times as much current to start as to run, their use should be avoided, whenever possible, if the electric motor is to be driven by a small generator. Capacitor and repulsion-induction motors require from 2 to 4 times as much current to start as to run. The current required to start any motor varies with the load connected to it. An electric motor connected to an air compressor, for example, will require more current than a motor to which no load is connected.

In general, the current required to start 115 volt motors connected to medium starting loads will be approximately as follows:

| MOTOR SIZE (HP) | AMPS FOR RUNNING (AMPERES) | AMPS FOR STARTING (AMPERES) |
|-----------------|----------------------------|-----------------------------|
| 1/6 | 3.2 | 6.4 TO 22.4 |
| 1/4 | 4.6 | 9.2 TO 32.2 |
| 1/3 | 5.2 | 10.4 TO 72.8 |
| 1/2 | 7.2 | 14.4 TO 29.2 |
| 3/4 | 10.2 | 20.4 TO 40.8 |
| 1 | 13 | 26 TO 52 |

NOTE: In the above table the maximum "AMPS FOR STARTING" is more for some small motors than for larger ones. The reason for this is that split-phase (the hardest starting types) are used in the smaller motors only.

Because the heavy surge of current needed for starting motors is required for only an instant, the generator will not be damaged if it can bring the motor up to speed in a few seconds. If difficulty is experienced in starting motors, turn off all other electrical loads and, if possible, reduce the load on the electric motor.

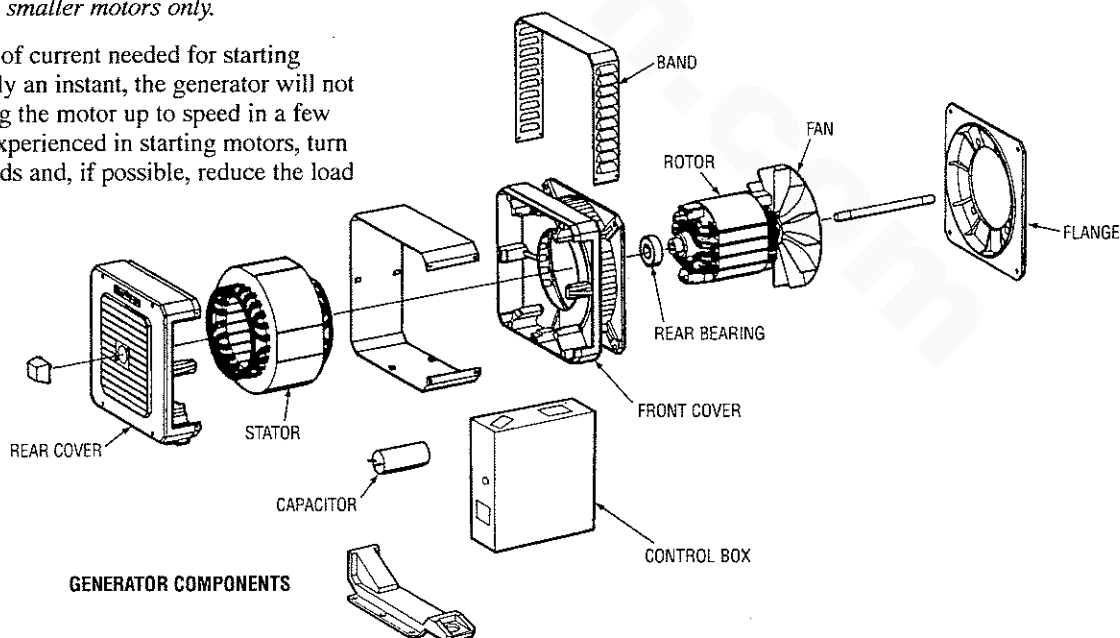

REQUIRED OPERATING SPEED

Although individual units may vary slightly, the normal voltage and frequency of typical 60 (50) hertz engine-driven generators described in this manual are approximately as follows: run first with no load applied, then at half the generator's capacity, and finally loaded to its full capacity as indicated on the generator's data plate.

The output voltage should be checked periodically to ensure proper operation of the generating plant and the appliances it supplies.

GENERATOR FREQUENCY ADJUSTMENT

- Frequency is a direct result of engine/generator speed, as indicated by the following:
- When the generator is run at 3600 rpm, the AC voltage output frequency is 60 hertz.
- When the generator is run at 3000 rpm, the AC voltage output frequency is 50 hertz.

Therefore, to change the generator's frequency, the generator's drive engine's speed must be changed. A reconfiguring of the AC output connections at the generator must also be made.

GENERATOR MAINTENANCE

Maintaining cleanliness is important. Do not allow salt, dust, or carbon from engine exhaust to build up on either the generator or its engine.



GENERATOR WIRING DIAGRAMS

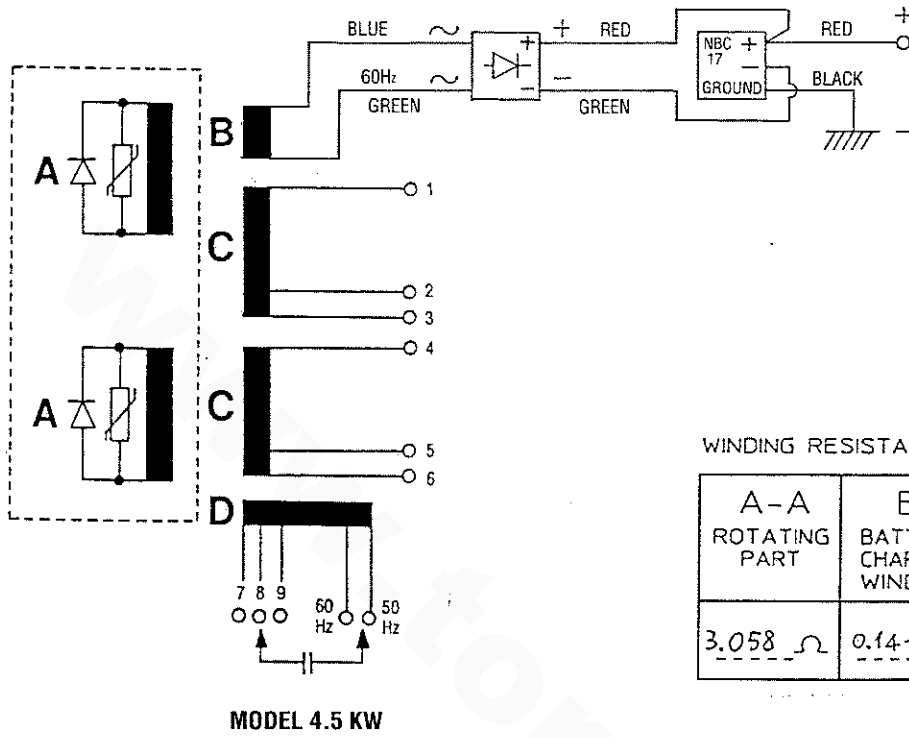

WINDING RESISTANCE AT 20° C TEMPERATURE

| A-A ROTATING PART | B BATTERY CHARGER WINDING | C-C STATOR WINDING | D EXC WINDING |
|-------------------------|------------------------------------|--------------------------|---------------------|
| 3.058 Ω | 0.141 Ω | 1-2 0.488 Ω | 50-8 4.334 Ω |
| | | 1-3 0.554 Ω | 60-8 3.456 Ω |
| | | 4-5 0.491 Ω | 50-7 4.594 Ω |
| | | 4-6 0.557 Ω | 60-7 3.714 Ω |

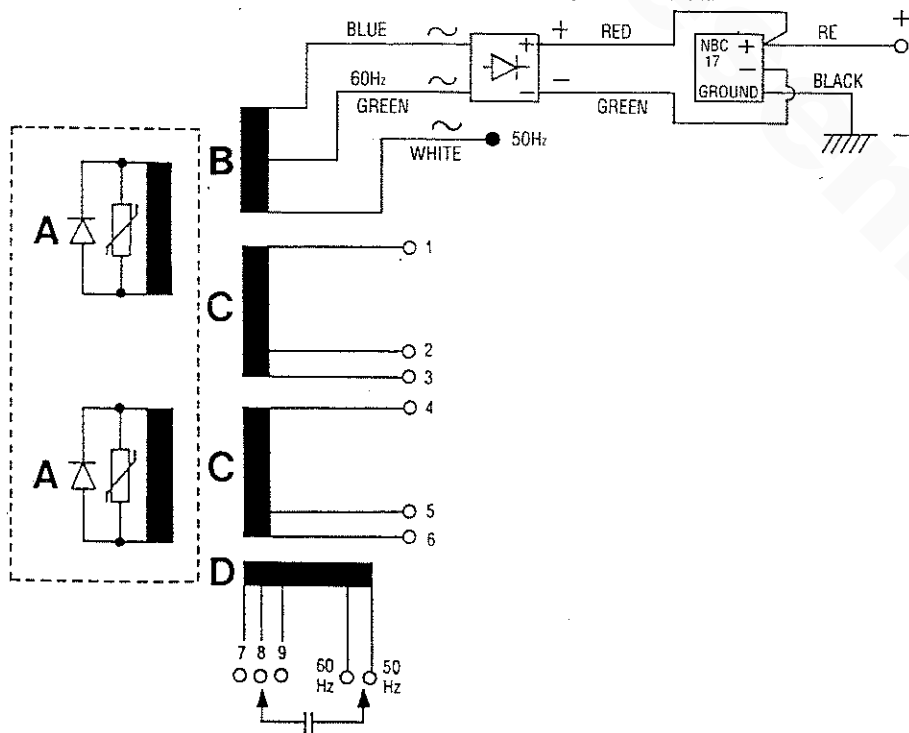

Rev. 6/1/98

AC ELECTRICAL CONNECTIONS

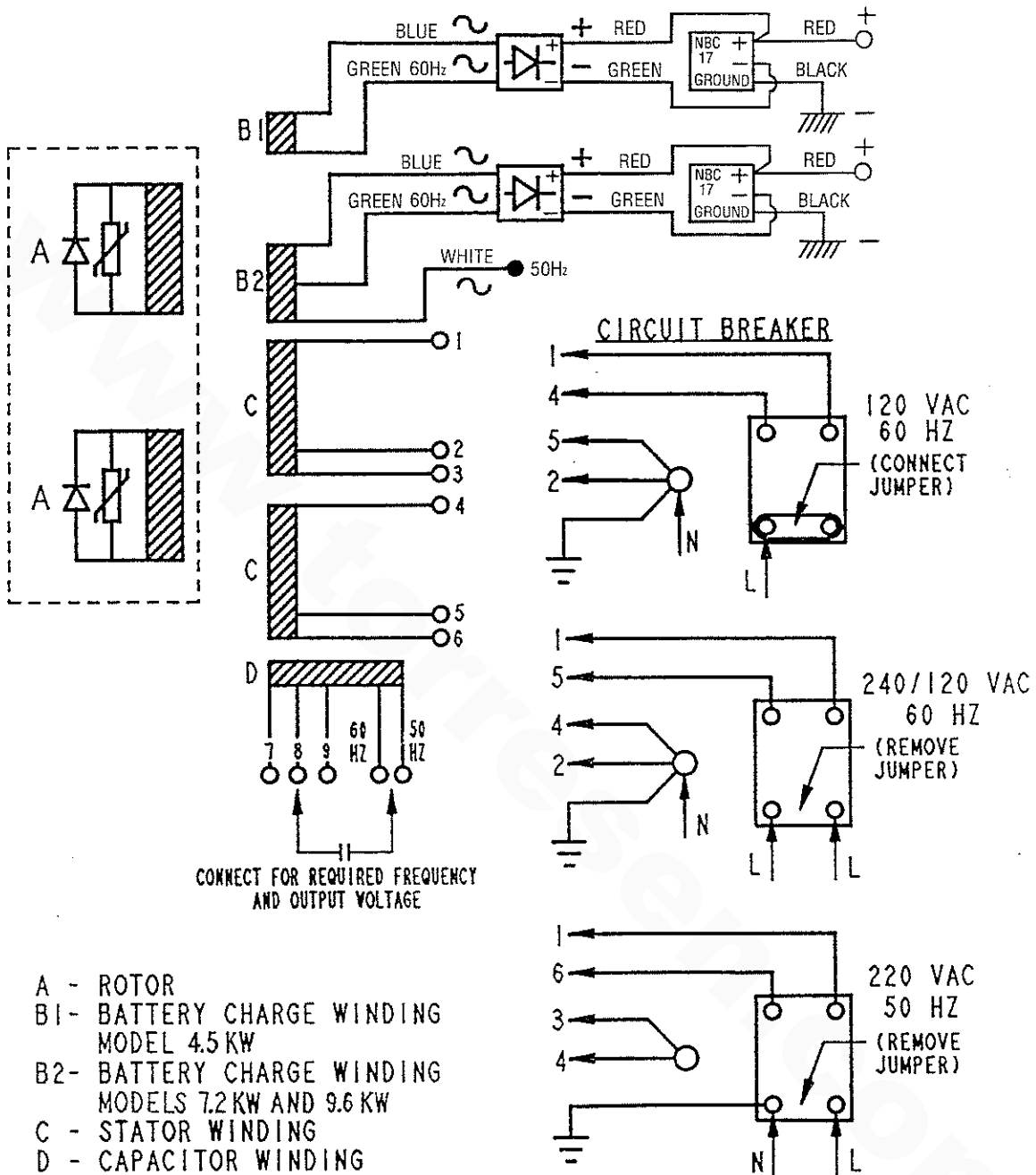

WARNING: When changing from 60Hz to 50Hz, make certain the ground wire (white & green stripe) is properly repositioned according to this diagram.

LAY-UP & RECOMMISSIONING

GENERAL

Many owners rely on their boatyards to prepare their craft, including engines and generators, for lay-up during the off-season or for long periods of inactivity. Others prefer to accomplish lay-up preparation themselves.

The procedures which follow will allow you to perform your own lay-up and recommissioning, or will serve as a checklist if others do the procedures.

These procedures should provide protection for your engine/generator during a lay-up and also help familiarize you with its maintenance needs.

If you have any questions regarding lay-up procedures, call your local servicing dealer. He will be more than willing to provide assistance.

FRESH WATER COOLING SYSTEM

A 50-50 solution of antifreeze and distilled water is recommended for use in the fresh water cooling system at all times. This solution may require a higher concentration of antifreeze, depending on the area's winter climate. Check the solution to make sure the antifreeze protection is adequate.

Should more antifreeze be needed, drain an appropriate amount from the engine block and add a more concentrated mixture. Operate the engine to ensure a complete circulation and mixture of the antifreeze concentration throughout the cooling system. Then recheck the antifreeze solution's strength.

LUBRICATION SYSTEM

With the engine warm, drain all the engine oil from the oil sump. Remove and replace the oil filter. (Place some paper towels and a plastic bag around the filter to catch the oil during its removal.)

When installing the new oil filter, be sure to apply a small amount of oil on the rubber sealing gasket at the base of the filter. Fill the sump with the correct amount of oil for your engine model. (Refer to the *SPECIFICATIONS* section of this manual.) Use an oil with an API specification of SJ. Run the engine and check for proper oil pressure and make sure there are no leaks or fuel spills.

CAUTION: Do not leave the engine's old engine oil in the sump over the lay-up period. Engine oil and combustion deposits combine to produce harmful chemicals which can reduce the life of your engine's internal parts.

FUEL SYSTEM

Top off your fuel tanks with *unleaded* gasoline of 89 octane or higher. A fuel conditioner such as *STABIL* gasoline stabilizer should be added. Change the element in your gasoline/water separator and clean the metal bowl. Re-install and make certain there are no leaks. Clean up any spilled fuel.

Start the engine and allow it to run for 5-10 minutes. Check for any leaks that may have been created in the fuel system during this servicing and correct them. Clean up any fuel spills.

RAW WATER CIRCUIT

Close the through-hull fitting. Remove the raw water intake hose from the fitting. Place the end of this hose into a 5-gallon bucket of clean fresh water. Before starting the engine, check the zinc anode in the heat exchanger on the engine and clean or replace it as required. Clean the raw water strainer, if one is installed on the inside of the hull.

Start the engine and allow the raw water pump to draw the fresh water through the system. When the bucket is empty, stop the engine and refill the bucket with an antifreeze solution slightly stronger than needed for winter freeze protection in your area.

Start the engine and allow all of this mixture to be drawn through the raw water system. Once the bucket is empty, stop the engine. This antifreeze mixture should protect the raw water circuit from freezing during the winter lay-up, as well as providing corrosion protection.

Remove the impeller from your raw water pump (some antifreeze mixture will accompany it, so catch it in a bucket).

Examine the impeller. Get a replacement, if needed, and a cover gasket. Do not replace the impeller (into the pump) until recommissioning, but replace the cover and gasket.

LAY-UP & RECOMMISSIONING

INTAKE MANIFOLD

Clean the filter screen in the flame arrester, and place a clean cloth lightly soaked in lube oil around the flame arrester to block any opening. Also place an oil-soaked cloth in the through-hull exhaust port. Make a note to remove cloths prior to start-up!

STARTER MOTOR

Lubrication and cleaning of the starter drive pinion is advisable, if access to the starter permits its removal. Make sure the battery connections are shut off before attempting to remove the starter. Take care in properly replacing any electrical connections removed from the starter.

CYLINDER LUBRICATION

Spray fogging oil into the open air intake, with the flame arrester removed, while the generator is running. The fogging oil will stall out the engine and coat the valves, cylinders and spark plugs for winter protection.

NOTE: *The spark plugs will need to be removed for cleaning and regapping at spring commissioning.*

SPARE PARTS

Lay-up time provides a good opportunity to inspect your WESTERBEKE engine to see if external items such as drive belts or coolant hoses need replacement. Check your basic spares kit and order items not on hand, or replace those items used during the lay-up, such as filters and zinc anodes.

BATTERIES

If batteries are to be left on-board during the lay-up period, make sure that they are fully charged, and will remain that way, to prevent them from freezing. If there is any doubt that the batteries will not remain fully charged, or that they will be subjected to severe environmental conditions, remove the batteries and store them in a warmer, more compatible environment.

⚠ WARNING: *Lead acid batteries emit hydrogen, a highly-explosive gas, which can be ignited by electrical arcing or a lighted cigarette, cigar, or pipe. Do not smoke or allow an open flame near the battery being serviced. Shut off all electrical equipment in the vicinity to prevent electrical arcing during servicing.*

RECOMMISSIONING

The recommissioning of your WESTERBEKE engine after a seasonal lay-up generally follows the same procedures as those presented in the *PREPARATIONS FOR INITIAL START-UP* section regarding preparation for starting and normal starts. However, some of the lay-up procedures will need to be counteracted before starting the engine.

1. Remove the oil-soaked cloths from the intake manifold and from the through-hull exhaust port.
2. Remove the raw water pump cover and gasket. Discard the gasket. Install the raw water pump impeller removed during lay-up (or a replacement, if required). Install the raw water pump cover with a new cover gasket.
3. Remove the spark plugs, wipe clean, re-gap, and install to proper tightness.
4. Reinstall the batteries that were removed during the lay-up, and reconnect the battery cables, making sure the terminals are clean and that the connections are tight. Check to make sure the batteries are fully charged.
5. Note that it is not necessary to flush the antifreeze/fresh water solution from the raw water coolant system. When the engine is put into operation, the system will self-flush in a short period of time with no adverse affects.
6. Start the engine in accordance with procedures in the *PREPARATIONS FOR INITIAL START-UP* section of this manual.

BCGTC GENERATOR SPECIFICATIONS

| ENGINE SPECIFICATIONS | |
|------------------------------|---|
| Engine Type | 3 cylinder, 4 cycle, overhead camshaft w/counterbalance shaft, carbureted, water cooled gasoline engine |
| Bore and Stroke | 2.56 x 2.61 in. (65.0 mm x 66.3 mm) |
| Total Displacement | 40.3 cu. in. (.66 liter) |
| Bearings | Four main bearings |
| Combustion Chamber | Semi-spherical |
| Compression ratio | 9.8 - 1 |
| Firing Order | 1 - 3 - 2 |
| Direction of Rotation | Counterclockwise viewed from the back end |
| Inclination | 25° continuous, all directions 30° temporary, all directions |
| Governor | Mechanical |

| FUEL SYSTEM | |
|-----------------------|---------------------------------------|
| Fuel Pump | Electric fuel pump |
| Fuel | Unleaded 89 octane or higher gasoline |
| Distributor | Breakerless distributor |
| Spark Plugs | 14 mm |
| Ignition Coil | 12 volt |
| Flame Arrester | Metal screen type |
| Carburetor | Single-barrel downdraft type |

| ELECTRICAL SYSTEM | |
|-------------------------|------------------------------------|
| Start Motor | 12 volt reduction gear w/solenoid |
| Starting Battery | 12 volt negative ground |
| Battery Capacity | 300 cold cranking amps (CCA) (min) |
| Battery Charging | Integral electric, 17 amps |

| AIR REQUIREMENTS | |
|---------------------------------------|------------------------------|
| Generator Cooling | 225-250 CFM (6.3-7.0 cmm) |
| Engine Combustion (all models) | 42 CFM (1.2 cmm) |
| Engine Cooling | 100 CFM (2.8 cmm) |

| EXHAUST EMISSIONS CONTROL SYSTEM | |
|------------------------------------|--|
| EM | Engine Modification |
| COOLING SYSTEM | |
| General | Fresh water-cooled block through raw water-cooled heat exchanger circuit |
| Fresh Water Pump | Centrifugal type, metal impeller, belt-driven |
| Raw Water Pump | Positive displacement, rubber impeller, belt-driven |
| Raw Water Flow, at 3600 RPM | 7.0-7.5 gpm (26.4-28.3 lpm) measured before discharge into water injected exhaust elbow. |
| Cooling Water Capacity | 3.5 qts. (3.4 liters) |
| LUBRICATING SYSTEM | |
| Type | Forced lubrication by gear pump |
| Oil Filter | Fuel flow, paper element spin-on disposals |
| Oil Capacity | 2.7 qts. (2.6 liters) |
| Oil Grade | API specification SJ class |

| AC GENERATOR SPECIFICATIONS | | | | | |
|--|--|--------------|-----------|------------|------------|
| Type | 2 pole capacitor regulated 50/60 hertz-1.0 power factor | | | | |
| Rating (minimum) | <u>rpm</u> | <u>Model</u> | <u>Hz</u> | <u>KVA</u> | <u>VAC</u> |
| | 3000 | 3.75 Kw | 50 | 3.75 | 230 |
| | 3000 | 6.0 Kw | 50 | 6.0 | 230 |
| | 3000 | 8.0 Kw | 50 | 8.0 | 230 |
| | 3600 | 4.5 Kw | 60 | 4.5 | 120 |
| | 3600 | 7.2 Kw | 60 | 7.2 | 120 |
| | 3600 | 9.6 Kw | 60 | 9.6 | 120 |
| Consult factory for 120/240 volt application | | | | | |

| TUNE-UP SPECIFICATIONS | |
|------------------------------|---|
| Spark Plug Gap | 0.031 ± .002 inches (0.8 ± 0.05 mm) |
| Spark Plug Torque | 10.8 - 15.2 lb-ft |
| Valve Clearances | Intake valves: 0.20 mm (.008 in) Exhaust valves: 0.30 mm (.012 in) |
| Timing Specifications | 18° ± .5° BTDC at 3600 rpm (no load on generator) |
| Cylinder Head | 60 - 70 Nm 43-51 ft-lbs |
| Bolt Torque | see <i>TORQUING THE CYLINDER HEAD BOLTS</i> under <i>ENGINE ADJUSTMENTS</i> |

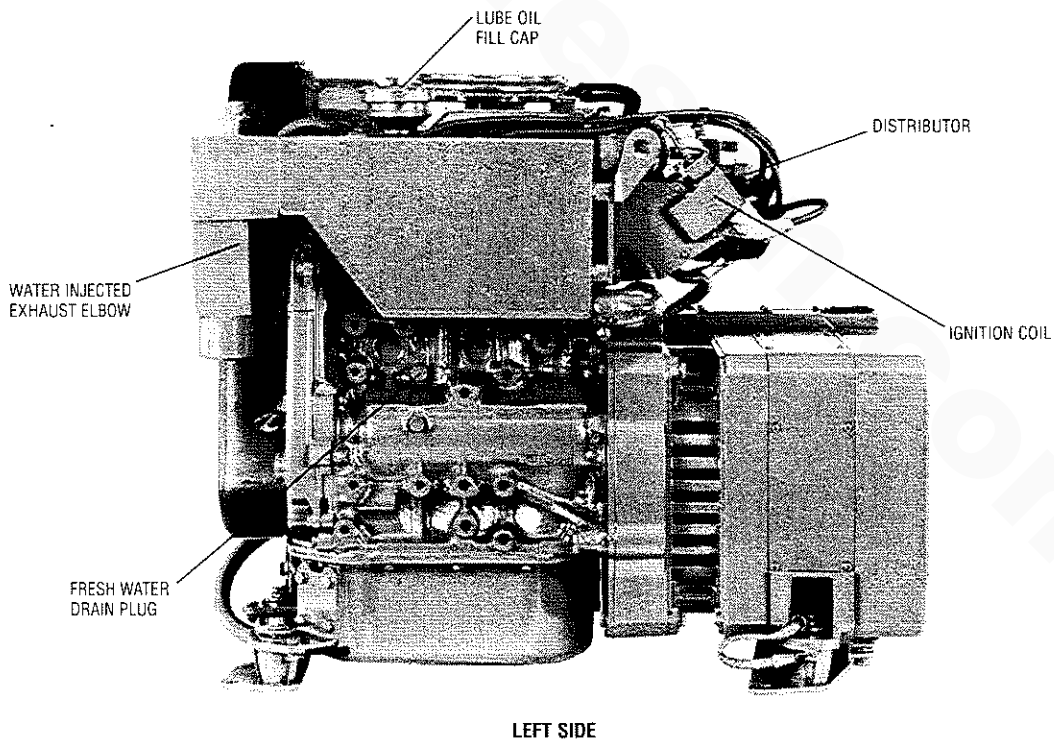
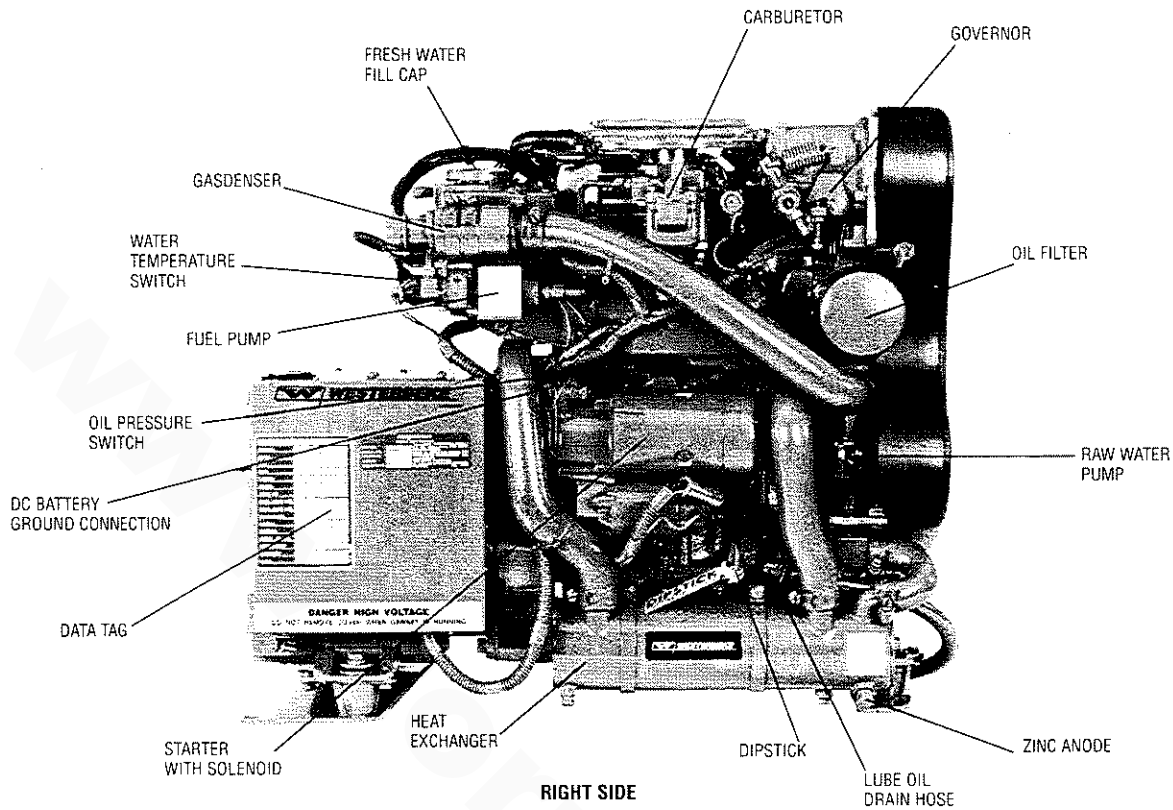

STANDARD HARDWARE TORQUES

NOTE: Unless stated otherwise for a specific assembly, use the following torque values when tightening standard hardware.

| Grade 4 | Pitch | lb-ft | kg-m |
|--------------------|------------|-----------|----------|
| 6mm bolt head/nut | 1 | 2.9-5.1 | 0.4-0.7 |
| 8mm bolt head/nut | 1.25 | 7.2-11.6 | 1.0-1.6 |
| 10mm bolt head/nut | 1.25 | 13.7-22.4 | 1.9-3.1 |
| 10mm bolt head/nut | 1.5 | 13.0-21.7 | 1.8-3.0 |
| 12mm bolt head/nut | 1.25 (ISO) | 25.3-39.8 | 3.5-5.5 |
| 12mm bolt head/nut | 1.5 | 25.3-39.8 | 3.5-5.5 |
| 12mm bolt head/nut | 1.75 | 21.7-36.2 | 3.0-5.0 |
| 13mm bolt head/nut | 1.5 | 32.5-50.6 | 4.5-7.0 |
| 14mm bolt head/nut | 1.5 | 36.2-57.9 | 5.0-8.0 |
| 14mm bolt head/nut | 2 | 34.0-55.7 | 4.7-7.7 |
| 16mm bolt head/nut | 1.5 | 54.2-79.6 | 7.5-11.0 |
| 16mm bolt head/nut | 2 | 51.4-76.7 | 7.1-10.6 |
| Grade 6T | | | |
| 6mm bolt head/nut | 1 | 4.3-6.5 | 0.6-0.9 |
| 8mm bolt head/nut | 1.25 | 10.8-15.9 | 1.5-2.2 |
| 10mm bolt head/nut | 1.25 | 21.7-32.5 | 3.0-4.5 |
| 10mm bolt head/nut | 1.5 | 19.5-30.4 | 2.7-4.2 |
| 12mm bolt head/nut | 1.25 (ISO) | 36.2-57.9 | 5.0-8.0 |
| 12mm bolt head/nut | 1.5 | 36.2-50.6 | 5.0-7.0 |
| 12mm bolt head/nut | 1.75 | 34.7-49.2 | 4.8-6.8 |

| Grade 7T, 8T and 8.8 | Pitch | lb-ft | kg-m |
|--------------------------|------------|-------------|-----------|
| 6mm bolt head/nut | 1 | 5.8-8.7 | 0.8-1.2 |
| 8mm bolt head/nut | 1.25 | 14.5-21.7 | 2.0-3.0 |
| 10mm bolt head/nut | 1.25 | 28.9-39.8 | 4.0-5.5 |
| 10mm bolt head/nut | 1.5 | 26.8-37.6 | 3.7-5.2 |
| 12mm bolt head/nut | 1.25 (ISO) | 54.2-75.9 | 7.5-10.5 |
| 12mm bolt head/nut | 1.5 | 50.6-65.1 | 7.0-9.0 |
| 12mm bolt head/nut | 1.75 | 43.4-61.5 | 6.0-8.5 |
| 13mm bolt head/nut | 1.5 | 57.9-86.8 | 8.0-12.0 |
| 14mm bolt head/nut | 1.5 | 72.3-108.5 | 10.0-15.0 |
| 14mm bolt head/nut | 2 | 68.7-101.3 | 9.5-14.0 |
| 16mm bolt head/nut | 1.5 | 108.5-166.4 | 15.0-23.0 |
| 16mm bolt head/nut | 2 | 101.3-159.1 | 14.0-22.0 |
| Grade 5 Cap Screw | | | |
| 1/4 UNC | | 9-11 | 1.2-1.5 |
| 1/4 UNF | | 11-13 | 1.5-1.8 |
| 5/16 UNC | | 18-20 | 2.5-2.8 |
| 5/16 UNF | | 21-23 | 2.9-3.2 |
| 3/8 UNC | | 28-33 | 3.7-4.6 |
| 3/8 UNF | | 30-35 | 4.1-4.8 |
| 7/16 UNC | | 44-49 | 6.1-6.8 |
| 7/16 UNF | | 50-55 | 6.9-7.6 |
| 1/2 UNC | | 68-73 | 9.4-10.1 |
| 1/2 UNF | | 73-80 | 10.1-11.1 |

BCGTC GENERATOR HARDWARE TORQUES

| | Nm | ft. lbs. |
|-------------------------------------|---------|----------|
| Timing Belt | | |
| Crankshaft bolt | 135-145 | 98-105 |
| Timing belt cover bolt | 10-12 | 7-9 |
| Camshaft sprocket bolt | 80-100 | 58-72 |
| Oil pump sprocket nut | 50-57 | 36-41 |
| Timing tensioner nut | 22-30 | 7-9 |
| Timing belt rear cover bolt | 10-12 | |
| Water Pump | | |
| Water pump | 8-10 | 6-7 |
| Rocker Arms and Rocker Shaft | | |
| Rocker cover shaft | 29-35 | 21-25 |
| Camshaft thrust plate bolt | 10-12 | 7-9 |
| Rocker arm adjust nut | 8-10 | 6-7 |
| Cylinder Head, Valve | | |
| Cylinder head bolt (cold engine) | 60-70 | 43-51 |

| | Nm | ft. lbs. |
|---|---------------|---------------|
| Front Case, Counterbalance Shaft | | |
| Front case bolt | 8-10 | 6-7 |
| Oil pump cover bolt | 8-10 | 6-7 |
| Oil pan bolt | 10-12 | 7-9 |
| Oil drain plug | 35-45 | 25-33 |
| Oil screen bolt | 15-22 | 11-16 |
| Oil pump driven gear bolt | 34-40 | 25-29 |
| Rear cover bolt | 10-12 | 7-9 |
| Piston and Connecting Rod | | |
| Connecting rod cap nut | 15 + 90° turn | 11 + 90° turn |
| Crankshaft, Bearing | | |
| Oil seal case bolt | 10-12 | 7-9 |
| Bearing cap bolt | 50-55 | 36-40 |
| Cylinder Block | | |
| Taper plug 1/16 | 8-12 | 6-9 |
| Taper plug 1/8 | 15-22 | 11-16 |
| Water drain plug | 35-45 | 25-33 |
| Taper plug pt-1/4 | 35-45 | 25-33 |



METRIC CONVERSIONS

| INCHES TO MILLIMETERS | | | | MILLIMETERS TO INCHES | | | |
|-----------------------|--------|--------|---------|-----------------------|--------|----|--------|
| Inches | mm | Inches | mm | mm | Inches | mm | Inches |
| 1 | 25.40 | 15 | 381.00 | 1 | 0.0394 | 15 | 0.5906 |
| 2 | 50.80 | 20 | 508.00 | 2 | 0.0787 | 20 | 0.7874 |
| 3 | 76.20 | 25 | 635.00 | 3 | 0.1181 | 25 | 0.9843 |
| 4 | 101.60 | 30 | 762.00 | 4 | 0.1575 | 30 | 1.1811 |
| 5 | 127.00 | 35 | 889.00 | 5 | 0.1969 | 35 | 1.3780 |
| 10 | 254.00 | 40 | 1016.00 | 10 | 0.3937 | 40 | 1.5748 |

10 MILLIMETERS = 1CENTIMETER, 100 CENTIMETERS = 1 METER = 39.37 INCHES (3.3 FEET)

| INCHES TO METERS | | | | METERS TO INCHES | | | |
|------------------|--------|--------|--------|------------------|--------|--------|--------|
| Inches | Meters | Inches | Meters | Meters | Inches | Meters | Inches |
| 1 | 0.0254 | 7 | 0.1778 | 0.1 | 3.937 | 0.7 | 27.559 |
| 2 | 0.0508 | 8 | 0.2032 | 0.2 | 7.874 | 0.8 | 31.496 |
| 3 | 0.0762 | 9 | 0.2286 | 0.3 | 11.811 | 0.9 | 35.433 |
| 4 | 0.1016 | 10 | 0.2540 | 0.4 | 15.748 | 1.0 | 39.370 |
| 5 | 0.1270 | 11 | 0.2794 | 0.5 | 19.685 | 1.1 | 43.307 |
| 6 | 0.1524 | 12 | 0.3048 | 0.6 | 23.622 | 1.2 | 47.244 |

TO CONVERT METERS TO CENTIMETERS, MOVE DECIMAL POINT TWO PLACES TO THE RIGHT

| YARDS TO METERS | | | | METERS TO YARDS | | | |
|-----------------|---------|-------|---------|-----------------|---------|--------|----------|
| Yards | Meters | Yards | Meters | Meters | Yards | Meters | Yards |
| 1 | 0.91440 | 6 | 5.48640 | 1 | 1.09361 | 6 | 6.56168 |
| 2 | 1.82880 | 7 | 6.40080 | 2 | 2.18723 | 7 | 7.65529 |
| 3 | 2.74320 | 8 | 7.31520 | 3 | 3.28084 | 8 | 8.74891 |
| 4 | 3.65760 | 9 | 8.22960 | 4 | 4.37445 | 9 | 9.84252 |
| 5 | 4.57200 | 10 | 9.14400 | 5 | 5.46807 | 10 | 10.93614 |

MOVE DECIMAL POINT FOR HIGHER VALUES — e.g. 6,000 METERS = 6,561.68 YARDS

| POUNDS TO KILOGRAMS | | | | KILOGRAMS TO POUNDS | | | |
|---------------------|-------|----|-------|---------------------|--------|----|--------|
| lb | kg | lb | kg | kg | lb | kg | lb |
| 1 | 0.454 | 6 | 2.722 | 1 | 2.205 | 6 | 13.228 |
| 2 | 0.907 | 7 | 3.175 | 2 | 4.409 | 7 | 15.432 |
| 3 | 1.361 | 8 | 3.629 | 3 | 6.614 | 8 | 17.637 |
| 4 | 1.814 | 9 | 4.082 | 4 | 8.818 | 9 | 19.842 |
| 5 | 2.268 | 10 | 4.536 | 5 | 11.023 | 10 | 22.046 |

| GALLONS TO LITERS | | | | LITERS TO GALLONS | | | |
|-------------------|--------|---------|--------|-------------------|---------|--------|---------|
| Gallons | Liters | Gallons | Liters | Liters | Gallons | Liters | Gallons |
| 1 | 3.79 | 10 | 37.86 | 1 | 0.26 | 60 | 15.66 |
| 2 | 7.57 | 20 | 75.71 | 2 | 0.53 | 90 | 23.77 |
| 3 | 11.36 | 30 | 113.57 | 5 | 1.32 | 120 | 31.32 |
| 4 | 15.14 | 40 | 151.42 | 10 | 2.64 | 150 | 39.62 |
| 5 | 18.93 | 50 | 189.28 | 20 | 5.28 | 180 | 47.54 |

| PINTS TO LITERS | | | | LITERS TO PINTS | | | |
|-----------------|--------|-------|--------|-----------------|-------|--------|-------|
| Pints | Liters | Pints | Liters | Liters | Pints | Liters | Pints |
| 1 | 0.47 | 6 | 2.84 | 1 | 2.11 | 6 | 12.68 |
| 2 | 0.95 | 7 | 3.31 | 2 | 4.23 | 7 | 14.79 |
| 3 | 1.42 | 8 | 3.79 | 3 | 6.34 | 8 | 16.91 |
| 4 | 1.89 | 9 | 4.26 | 4 | 8.45 | 9 | 19.02 |
| 5 | 2.37 | 10 | 4.73 | 5 | 10.57 | 10 | 21.13 |

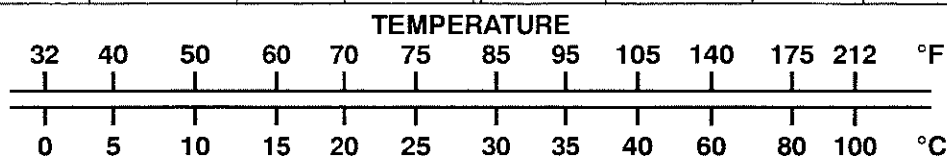

SUGGESTED SPARE PARTS

WESTERBEKE MARINE GASOLINE GENERATORS

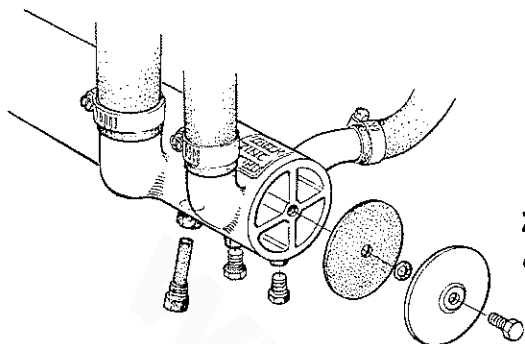

Heat Exchanger End Gasket

Check annually.



Zinc Anodes

Carry several.

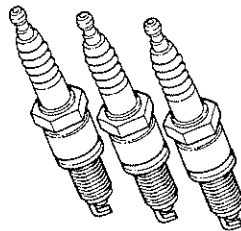

Spark Plugs

Always carry a full set.

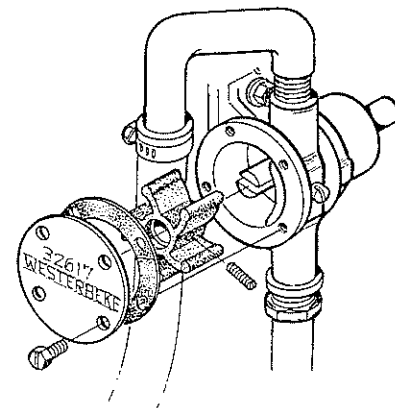

Raw Water Impeller and Gasket

Check annually.

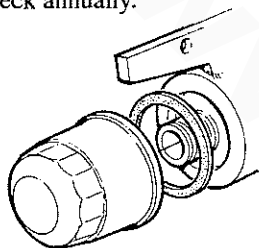

Oil Filter

Have several aboard.
Change every 100 hours.

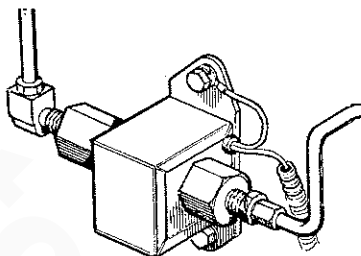

Fuel Lift Pump

Solid State Model. Have a spare on board.

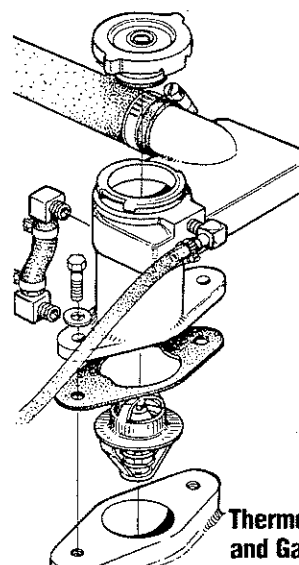

Thermostat and Gasket

Always carry a spare aboard.

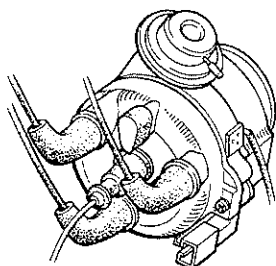

Distributor Cap and Wires

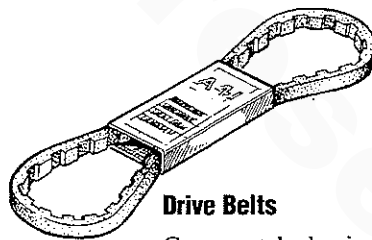

Drive Belts

Carry matched pairs.
Inspect every 100 hours.

SPARE PARTS KITS

WESTERBEKE also offers two Spare Parts Kits, each packaged in a rugged hinged toolbox. Kit A includes the basic spares. Kit B is for more extensive off-shore cruising.

KIT A

- Impeller Kit
- Heat Exchanger Gasket
- Oil Filter
- Drive Belts
- Zinc Anodes
- Spark Plugs

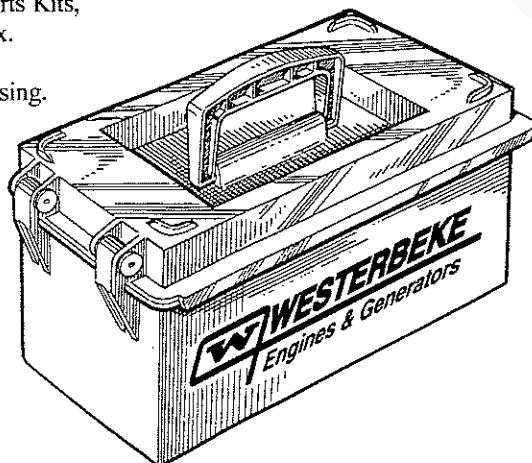

KIT B

- Impeller Kit
- Water Pump Repair Kit
- Thermostat Kit
- Zinc Anodes
- Complete Gasket Kit
- Heat Exchanger Gasket
- Oil Filter
- Drive Belts
- Spark Plugs



www.torresen.com

