



SERVICE MANUAL

55A FOUR MARINE DIESEL ENGINE

PUBLICATION #43377
1st Edition / September 1998



**CALIFORNIA
PROPOSITION 65 WARNING**

Diesel engine exhaust and some of its constituents are known to the State of California to cause cancer, birth defects, and other reproductive harm.



WARNING

Exhaust gasses contain Carbon Monoxide, an odorless and colorless gas. Carbon Monoxide is poisonous and can cause unconsciousness and death. Symptoms of Carbon Monoxide exposure can include:

- *Dizziness*
- *Nausea*
- *Headache*
- *Weakness and Sleepiness*
- *Throbbing in Temples*
- *Muscular Twitching*
- *Vomiting*
- *Inability to Think Coherently*

IF YOU OR ANYONE ELSE EXPERIENCE ANY OF THESE SYMPTOMS, GET OUT INTO THE FRESH AIR IMMEDIATELY. If symptoms persist, seek medical attention. Shut down the unit and do not restart until it has been inspected and repaired.

SAFETY INSTRUCTIONS

INTRODUCTION

Read these safety instructions carefully. Most accidents are caused by failure to follow fundamental rules and precautions. Know when dangerous conditions exist and take the necessary precautions to protect yourself, your personnel, and your machinery.

The following safety instructions are in compliance with the American Boat and Yacht Council (ABYC) standards.

PREVENT ELECTRIC SHOCK

⚠ WARNING: *Do not touch AC electrical connections while engine is running, or when connected to shore power. Lethal voltage is present at these connections!*

- Do not operate this machinery without electrical enclosures and covers in place.
- Shut off electrical power before accessing electrical equipment.
- Use insulated mats whenever working on electrical equipment.
- Make sure your clothing and skin are dry, not damp (particularly shoes) when handling electrical equipment.
- Remove wristwatch and all jewelry when working on electrical equipment.
- Do not connect utility shore power to vessel's AC circuits, except through a ship-to-shore double throw transfer switch. Damage to vessel's AC generator may result if this procedure is not followed.
- Electrical shock results from handling a charged capacitor. Discharge capacitor by shorting terminals together.

PREVENT BURNS — HOT ENGINE

⚠ WARNING: *Do not touch hot engine parts or exhaust system components. A running engine gets very hot!*

- Always check the engine coolant level at the coolant recovery tank.

⚠ WARNING: *Steam can cause injury or death!*

- In case of an engine overheat, allow the engine to cool before touching the engine or checking the coolant.

PREVENT BURNS — FIRE

⚠ WARNING: *Fire can cause injury or death!*

- Prevent flash fires. Do not smoke or permit flames or sparks to occur near the carburetor, fuel line, filter, fuel pump, or other potential sources of spilled fuel or fuel vapors. Use a suitable container to catch all fuel when removing the fuel line, carburetor, or fuel filters.
- Do not operate with a Coast Guard Approved flame arrester removed. Backfire can cause severe injury or death.
- Do not operate with the air cleaner/silencer removed. Backfire can cause severe injury or death.
- Do not smoke or permit flames or sparks to occur near the fuel system. Keep the compartment and the engine/generator clean and free of debris to minimize the chances of fire. Wipe up all spilled fuel and engine oil.
- Be aware — diesel fuel will burn.

PREVENT BURNS — EXPLOSION

⚠ WARNING: *Explosions from fuel vapors can cause injury or death!*

- Follow re-fueling safety instructions. Keep the vessel's hatches closed when fueling. Open and ventilate cabin after fueling. Check below for fumes/vapor before running the blower. Run the blower for four minutes before starting your engine.
- All fuel vapors are highly explosive. Use extreme care when handling and storing fuels. Store fuel in a well-ventilated area away from spark-producing equipment and out of the reach of children.
- Do not fill the fuel tank(s) while the engine is running.
- Shut off the fuel service valve at the engine when servicing the fuel system. Take care in catching any fuel that might spill. DO NOT allow any smoking, open flames, or other sources of fire near the fuel system or engine when servicing. Ensure proper ventilation exists when servicing the fuel system.
- Do not alter or modify the fuel system.
- Be sure all fuel supplies have a positive shutoff valve.
- Be certain fuel line fittings are adequately tightened and free of leaks.
- Make sure a fire extinguisher is installed nearby and is properly maintained. Be familiar with its proper use. Extinguishers rated ABC by the NFPA are appropriate for all applications encountered in this environment.



SAFETY INSTRUCTIONS

ACCIDENTAL STARTING

⚠ WARNING: Accidental starting can cause injury or death!

- Disconnect the battery cables before servicing the engine/generator. Remove the negative lead first and reconnect it last.
- Make certain all personnel are clear of the engine before starting.
- Make certain all covers, guards, and hatches are re-installed before starting the engine.

BATTERY EXPLOSION

⚠ WARNING: Battery explosion can cause injury or death!

- Do not smoke or allow an open flame near the battery being serviced. Lead acid batteries emit hydrogen, a highly explosive gas, which can be ignited by electrical arcing or by lit tobacco products. Shut off all electrical equipment in the vicinity to prevent electrical arcing during servicing.
- Never connect the negative (-) battery cable to the positive (+) connection terminal of the starter solenoid. Do not test the battery condition by shorting the terminals together. Sparks could ignite battery gases or fuel vapors. Ventilate any compartment containing batteries to prevent accumulation of explosive gases. To avoid sparks, do not disturb the battery charger connections while the battery is being charged.
- Avoid contacting the terminals with tools, etc., to prevent burns or sparks that could cause an explosion. Remove wristwatch, rings, and any other jewelry before handling the battery.
- Always turn the battery charger off before disconnecting the battery connections. Remove the negative lead first and reconnect it last when servicing the battery.

BATTERY ACID

⚠ WARNING: Sulphuric acid in batteries can cause severe injury or death!

- When servicing the battery or checking the electrolyte level, wear rubber gloves, a rubber apron, and eye protection. Batteries contain sulfuric acid which is destructive. If it comes in contact with your skin, wash it off at once with water. Acid may splash on the skin or into the eyes inadvertently when removing electrolyte caps.

TOXIC EXHAUST GASES

⚠ WARNING: Carbon monoxide (CO) is a deadly gas!

- Ensure that the exhaust system is adequate to expel gases discharged from the engine. Check the exhaust system regularly for leaks and make sure the exhaust manifolds are securely attached and no warping exists. Pay close attention to the manifold, water injection elbow, and exhaust pipe nipple.
- Be sure the unit and its surroundings are well ventilated.
- In addition to routine inspection of the exhaust system, install a carbon monoxide detector. Consult your boat builder or dealer for installation of approved detectors.
- For additional information refer to ABYC T-22 (educational information on Carbon Monoxide).

⚠ WARNING: Carbon monoxide (CO) is an invisible odorless gas. Inhalation produces flu-like symptoms, nausea or death!

- Do not use copper tubing in diesel exhaust systems. Diesel fumes can rapidly destroy copper tubing in exhaust systems. Exhaust sulfur causes rapid deterioration of copper tubing resulting in exhaust/water leakage.
- Do not install exhaust outlet where exhaust can be drawn through portholes, vents, or air conditioners. If the engine exhaust discharge outlet is near the waterline, water could enter the exhaust discharge outlet and close or restrict the flow of exhaust. Avoid overloading the craft.
- Although diesel engine exhaust gases are not as toxic as exhaust fumes from gasoline engines, carbon monoxide gas is present in diesel exhaust fumes. Some of the symptoms or signs of carbon monoxide inhalation or poisoning are:

Vomiting
Dizziness
Throbbing in temples
Muscular twitching
Intense headache
Weakness and sleepiness

AVOID MOVING PARTS

⚠ WARNING: Rotating parts can cause injury or death!

- Do not service the engine while it is running. If a situation arises in which it is absolutely necessary to make operat-



SAFETY INSTRUCTIONS

ing adjustments, use extreme care to avoid touching moving parts and hot exhaust system components.

- Do not wear loose clothing or jewelry when servicing equipment; avoid wearing loose jackets, shirts, sleeves, rings, necklaces or bracelets that could be caught in moving parts.
- Make sure all attaching hardware is properly tightened. Keep protective shields and guards in their respective places at all times.
- Do not check fluid levels or the drive belt's tension while the engine is operating.
- Stay clear of the drive shaft and the transmission coupling when the engine is running; hair and clothing can easily be caught in these rotating parts.

HAZARDOUS NOISE

 **WARNING: High noise levels can cause hearing loss!**

- Never operate an engine without its muffler installed.
- Do not run an engine with the air intake (silencer) removed.
- Do not run engines for long periods with their enclosures open.

 **WARNING: Do not work on machinery when you are mentally or physically incapacitated by fatigue!**

OPERATORS MANUAL

Many of the preceding safety tips and warnings are repeated in your Operators Manual along with other cautions and notes to highlight critical information. Read your manual carefully, maintain your equipment, and follow all safety procedures.

ENGINE INSTALLATIONS

Preparations to install an engine should begin with a thorough examination of the American Boat and Yacht Council's (ABYC) standards. These standards are a combination of sources including the USCG and the NFPA.

Sections of the ABYC standards of particular interest are:

- H-2 Ventilation
- P-1 Exhaust systems
- P-4 Inboard engines
- E-9 DC Electrical systems

All installations must comply with the Federal Code of Regulations (FCR).

ABYC, NFPA AND USCG PUBLICATIONS FOR INSTALLING DIESEL ENGINES

Read the following ABYC, NFPA and USCG publications for safety codes and standards. Follow their recommendations when installing your engine.

ABYC (American Boat and Yacht Council)
"Safety Standards for Small Craft"

Order From:

ABYC
3069 Solomon's Island Rd.
Edgewater, MD 21037

NFPA (National Fire Protection Association)
"Fire Protection Standard for Motor Craft"

Order From:

NFPA
11 Tracy Drive
Avon Industrial Park
Avon, MA 02322

USCG (United States Coast Guard)
"USCG 33CFR183"

Order From:

U.S. Government Printing Office
Washington, D.C. 20404

INSTALLATION

When installing WESTERBEKE engines and generators it is important that strict attention be paid to the following information:

CODES AND REGULATIONS

Strict federal regulations, ABYC guidelines, and safety codes must be complied with when installing engines and generators in a marine environment.

SIPHON-BREAK

For installations where the exhaust manifold/water injected exhaust elbow is close to or below the vessel's waterline, provisions must be made to install a siphon-break in the raw water supply hose to the exhaust elbow. This hose must be looped a minimum of 18" above the vessel's waterline. *Failure to use a siphon-break when the exhaust manifold injection port is at or below the load waterline will result in raw water damage to the engine and possible flooding of the boat.*

EXHAUST SYSTEM

The exhaust hose must be certified for marine use. The system must be designed to prevent water from entering the exhaust under any sea conditions and at any angle of the vessels hull.

A detailed 40 page Marine Installation Manual covering gasoline and diesel, engines and generators, is available from your WESTERBEKE dealer.

TABLE OF CONTENTS

Introduction	2
55A FOUR Specifications	4
Parts Identification	5
Testing for Overhaul	6
Engine Troubleshooting	7
Engine Disassembly	11
Engine Inspection and Repair	16
Engine Reassembly	26
Engine Adjustments	42
Glow Plugs	51
Lubrication System	52
Remote Oil Filter (Optional)	57
Coolant Pump	58
Raw Water Pump	59
Heat Exchanger	60
Intake/Exhaust Manifold	61
Tachometer	62
Starter Motor	63
DC Electrical System/Alternator	67
DC Electrical System — Wiring Diagram	70
DC Electrical System — Wiring Schematic	71
Transmissions	72
Service Standards	73
Metric Conversions	77
55A FOUR Torques	78
Standard Hardware Torques, General Screws, Sealants	79
Index	80



INTRODUCTION

ENGINE OVERHAUL

This service manual contains detailed information relating to the overhaul of the 55A FOUR Diesel Engine. For the major overhaul procedure, refer to the *ENGINE DISASSEMBLY*, *ENGINE INSPECTION AND REPAIR*, and *ENGINE REASSEMBLY* sections. Additional service information for specific components and systems may be found by referring to the *Table of Contents* and the *Index*. Refer also to your WESTERBEKE Parts Catalog.

These service procedures are intended for the guidance of suitably equipped and staffed marine engine service and rebuilding facilities, and should only be undertaken by such facilities and their personnel.

PRODUCT SOFTWARE

Product software (tech data, parts lists, manuals, brochures and catalogs) provided from sources other than WESTERBEKE are not within WESTERBEKE'S control.

WESTERBEKE CANNOT BE RESPONSIBLE FOR THE CONTENT OF SUCH SOFTWARE, MAKES NO WARRANTIES OR REPRESENTATIONS WITH RESPECT THERETO, INCLUDING ACCURACY, TIMELINESS OR COMPLETENESS THEREOF AND WILL IN NO EVENT BE LIABLE FOR ANY TYPE OF DAMAGE OR INJURY INCURRED IN CONNECTION WITH OR ARISING OUT OF THE FURNISHING OR USE OF SUCH SOFTWARE.

WESTERBEKE customers should also keep in mind the time span between printings of WESTERBEKE product software and the unavoidable existence of earlier WESTERBEKE manuals. Product software provided with WESTERBEKE products, whether from WESTERBEKE or other suppliers, must not and cannot be relied upon exclusively as the definitive authority on the respective product. It not only makes good sense but is imperative that appropriate representatives of WESTERBEKE or the supplier in question be consulted to determine the accuracy and currentness of the product software being consulted by the customer.

NOTES, CAUTIONS AND WARNINGS

As this manual takes you through the service procedures and troubleshooting of your marine engine, critical information will be highlighted by *NOTES*, *CAUTIONS*, and *WARNINGS*. An explanation follows:

NOTE: *An operating procedure essential to note.*

CAUTION: *Procedures, which if not strictly observed, can result in the damage or destruction of your engine.*

WARNING: *Procedures, which if not properly followed, can result in personal injury or loss of life.*

CUSTOMER IDENTIFICATION CARD



Customer Identification
MR. ENGINE OWNER
MAIN STREET
HOMETOWN, USA
Model 55A FOUR Ser. #U0000-D702
Expires 4/4/98

The WESTERBEKE engine serial number is an alphanumeric number that can assist in determining the date of manufacture of your WESTERBEKE engine. The manufacturer's date code is placed at the end of the engine serial number and consists of a character followed by three numbers. The character indicates the decade (A=1960s, B=1970s, C=1980s, D=1990s), the first number represents the year in the decade, and the second and third numbers represent the month of manufacture.

ORDERING PARTS/SERIAL NUMBER LOCATION

Whenever replacement parts are needed, always provide the engine model number and engine serial number as they appear on the silver and black identification nameplate located on the side of the manifold. The engine serial number can also be found stamped into the engine block just above the injection pump. You must provide us with this information so we may properly identify your engine. In addition, include a complete part description and part number for each part needed (see the separately furnished Parts List). Also insist upon WESTERBEKE packaged parts because *will fit* or generic parts are frequently not made to the same specifications as original equipment.

NOTE: *Component locations in this manual are referenced from the front of the engine which is the pulley/drive belt end. Left and right sides are determined as follows: imagine straddling the engine, facing in the same direction as the front of the engine: the left side is at your left, the right side is at your right.*

Owners may find it convenient to fill in the engine identification nameplate shown below to provide a quick reference when using this service manual.



INTRODUCTION

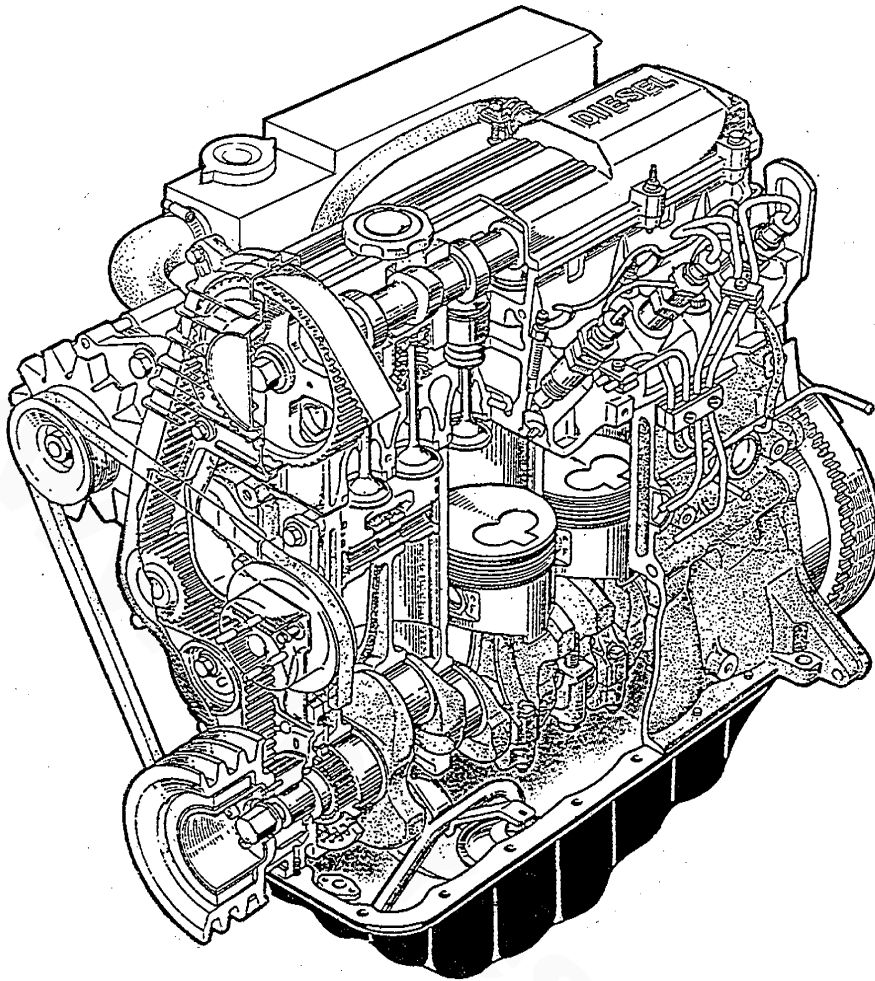

55A FOUR DIESEL ENGINE

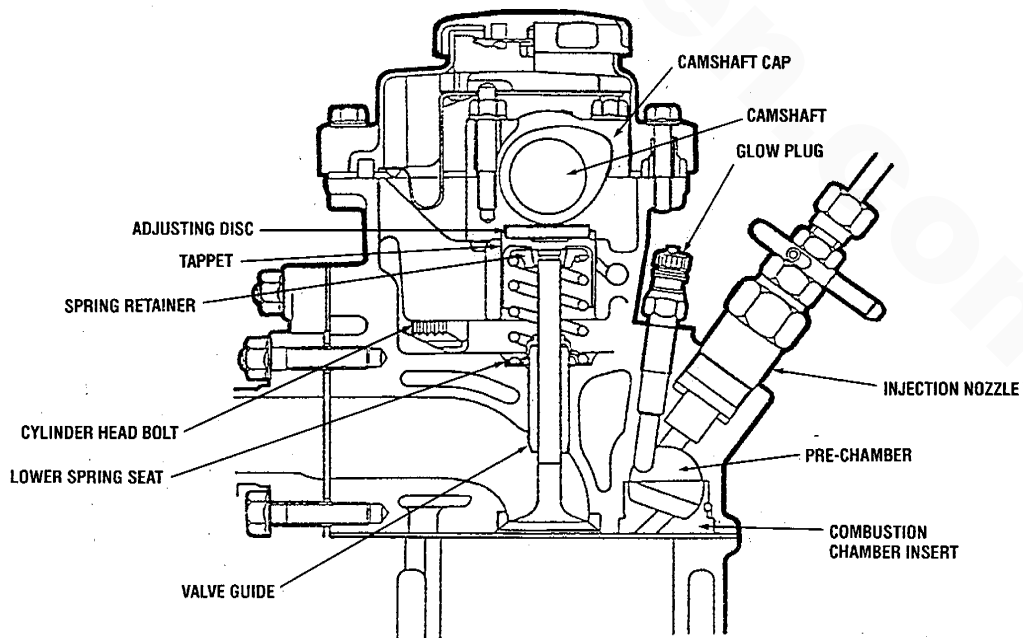

55A FOUR SPECIFICATIONS

ENGINE SPECIFICATIONS

Engine Type	Diesel, four-cycle, four-cylinder, fresh-water-cooled, vertical, in-line (55 hp at 3600 rpm maximum)
Governor	Integral with the injection pump, mechanical centrifugal flyweight type
Valve Mechanism	Direct drive, OHC
Combustion Chamber	Swirl chamber type
Bore and Stroke	3.38 x 3.70 inches (86.0 x 94.0 mm)
Piston Displacement	133.2 cubic inches (2.18 liters)
Firing Order	1-3-4-2
Direction of Rotation	Clockwise, when viewed from the front of the engine (pulley drive belt end)
Maximum Torque (at 1920 rpm)	93 lb-ft (12.9 kg-m)
Compression Ratio	22.7:1
Compression Pressure	426 psi (30 kg/cm ²) at 200 rpm
Valve Seat Angle	Intake 45°, Exhaust 45°
Valve Clearance (engine cold)	Intake .008 – 0.012 in. (0.20 – 0.30mm) Exhaust 0.012–0.016 in. (0.30–0.40 mm)
Dimensions	Height: 26.78 inches (680.2 mm) Width: 50.0 inches (546.1 mm) Length: 35.0 inches (889.0 mm)
Inclination	Continuous 14°; Temporary 25° (not to exceed 30°)
Dry Weight	470 lbs (213.2 kgs)
Engine Speed	Idle speed: 750 – 1000 rpm Cruising speed: 2500 – 3000 rpm
Fuel Consumption	1.5 U.S. gph (5.6 lph) running at 2500 rpm (approximate) when the propeller allows 3600 rpm at full open throttle while underway in forward gear

FUEL SYSTEM

Fuel	No. 2 diesel oil (cetane rating of 45 or higher)
Injection Pump	Zexel mechanical governed
Injection Timing	0° TDC
Injectors	Throttle type
Injection Pressure	1920 psi + 71 psi (135 kg/cm ² + 5 kg/cm ²)
Lift Pump	12 volt – plunger type
Fuel Filter (on engine)	Spin-on type (replaceable)
Fuel Supply and Return Piping	.250 in (.635 mm) I.D. minimum .375 in (.925 mm) I.D. maximum
Air Cleaner	Replaceable paper filter element
Air Flow (engine combustion) (engine cooling)	140 cfm (3.9 cmm) at 3600 rpm 250 cfm (7.0 cmm)

EXHAUST SYSTEM

Exhaust Elbow	90° elbow, 45° elbow and exhaust riser
Exhaust Hose Size	2 inch I.D. hose
Muffler Size (min.)	14 inch x 14 inch

COOLING SYSTEM

General	Freshwater-cooled block, thermostatically controlled with raw water exchanger system
Operating Temperature	170 – 190°F (77 – 88°C)
Coolant Pump	Centrifugal type, metal impeller, belt-driven
Raw Water Pump	Positive displacement, rubber impeller, belt driven
Raw Water Flow, at 3600 rpm (measured before discharging into exhaust elbow)	16.0 gpm (60.5 lpm) approximate
Coolant System Capacity	9.5 U.S. qts (9.0 liters)

ELECTRICAL SYSTEM

Starting Battery	12-volt DC, (–) negative ground
Battery Capacity	300 – 400 Cold cranking amps (CCA) (min.)
Starter Motor	12-volt, 1.6kw, solenoid, actuated shift reduction gear
Starting Aid	12 volt sheathed type glow plug
DC No-Load Current	100 amps at 11.5 volts (3000 rpm, min.)
Cold Cranking Current	280 – 300 amps at 10 volts (250 rpm, min.)
Alternator (standard)	12-volt, DC, 50 amps
Regulator	Internal regulator, built into alternator

TRANSMISSION

General	(<i>Hurth Standard Transmission</i>) Case-hardened helical gears, with a servo-operated multiple disc clutch.
Gear ratio (standard)	2.74 : 1 (HBW250 – 3R)
Propeller Shaft	Right handed – standard transmission
Propeller	20 D x 13 P – 2 blade or 20 D x 11 P – 3 blade propeller should allow the engine to reach its full rated rpm (3600 + 000 – 100) at full open throttle while underway in forward gear.
Recommendations (using standard transmission 2.74:1 reduction)	
Lubricating Fluid	ATF – type A or Dextron – II or III
Transmission Sump Capacity	0.79 U.S. qts (0.75 liters) approximate

LUBRICATION SYSTEM

Oil Pump	Crescent type directly driven by the crankshaft.
Oil Filter	Full flow, paper element, spin-on type
Lube Oil Cooler	Fresh water cooled.
Lubricant Capacity	1.75 U.S. gal. (6.6. liters)
Sump Capacity	5.0 U.S. qts (4.8 liters) not including filter
Operating Oil Pressure	30 – 60 psi (2.1 – 4.2 kg/cm ²) at maximum engine rpm and at normal operating temperature
Oil Grade	API Specification CF or CG-4, SAE 30, 10W-30, 15W-40



PARTS IDENTIFICATION

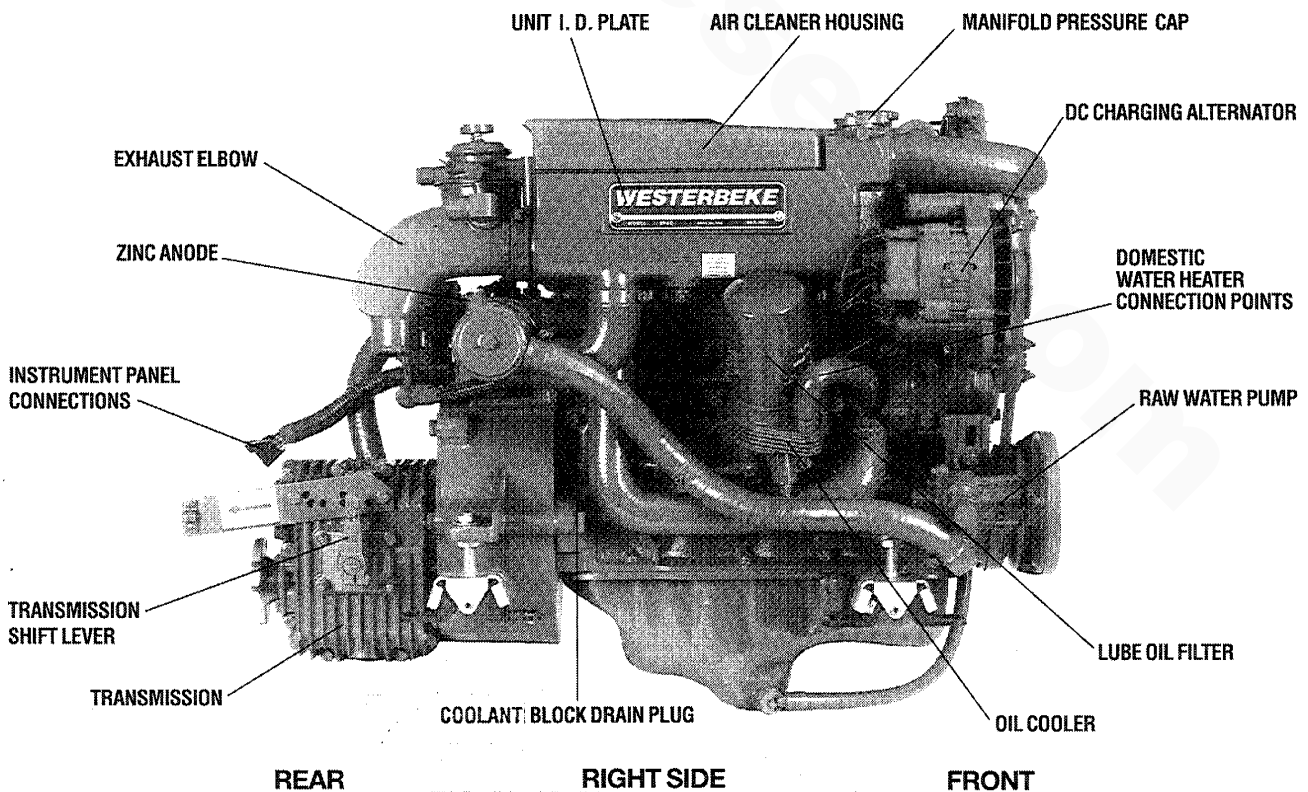
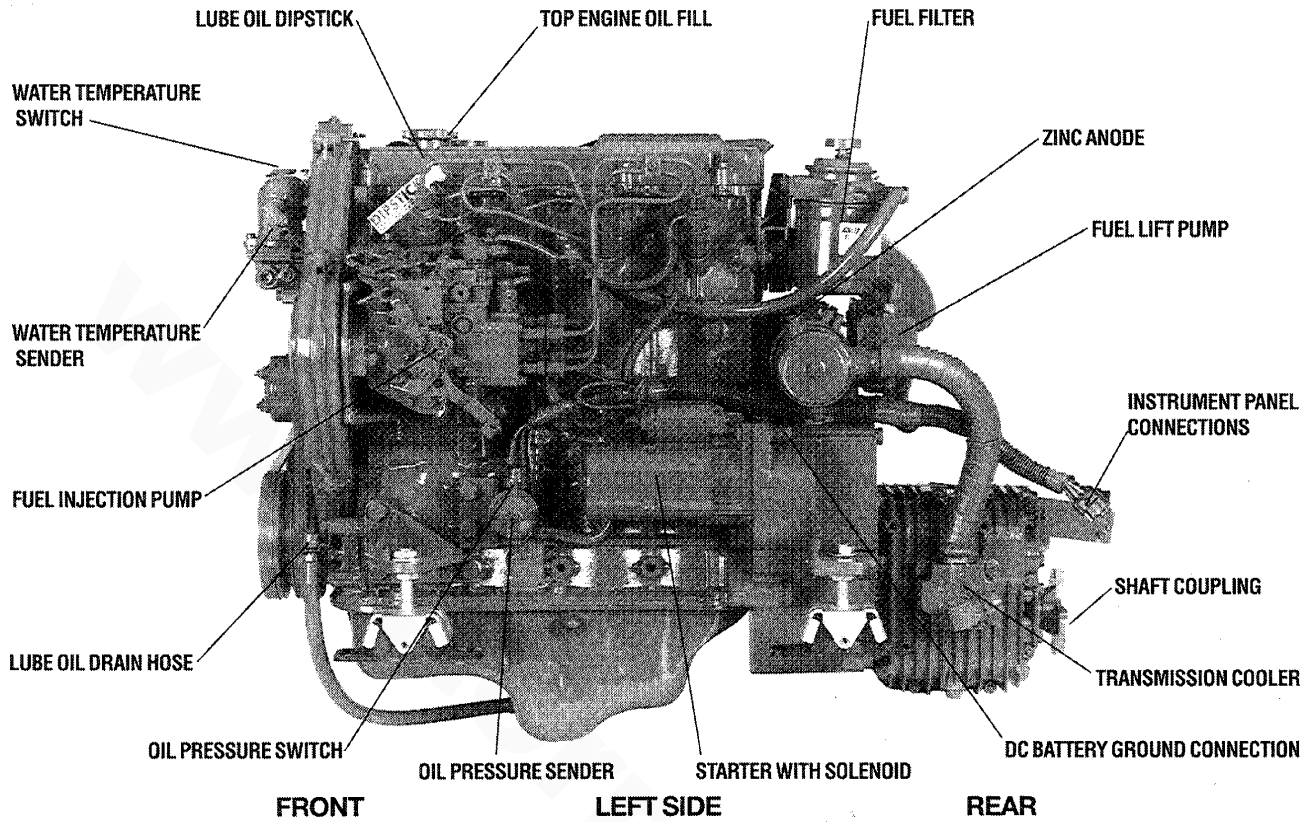

TESTING FOR OVERHAUL

HOW TO DETERMINE WHEN TO OVERHAUL THE ENGINE

Cause of Low Compression

Generally, the time at which an engine should be overhauled is determined by various conditions such as lowered engine power output, decreased compression pressure, and increased fuel and oil consumption. The lowered engine power output, in the case of diesel engines, is not necessarily due to trouble with the engine itself, but is sometimes caused by injector nozzle wear or injection pump wear. It is most reasonable to judge by a decrease in compression pressure. The decrease in compression pressure is caused by many factors. It is, therefore, necessary to determine a cause or causes on the basis of data produced by periodic inspection and maintenance. Oil analysis on a seasonal basis is a good means of monitoring engine internal wear. When caused by worn cylinders or piston rings, the following symptoms will occur:

- Low engine power output
- Increased fuel consumption
- Increased oil consumption
- Hard engine starting
- Noisy engine operation

These symptoms often appear together. Increased fuel consumption and hard engine starting can result also from excessive fuel injection, improper injection timing, and wear of plugs and nozzles. They are caused also by defective electrical devices such as the battery, alternator, starter and glow plugs. Therefore it is desirable to judge the optimum engine overhaul time by the lowered compression pressure caused by worn cylinders and pistons plus increased oil consumption. In diesel engines, satisfactory combustion is obtained only under sufficient compression pressure. If an engine lacks compression pressure, incomplete combustion of fuel will take place even if other parts of the engine are operating properly. To determine the period of engine overhaul, it is important to measure the engine compression pressure regularly. At the same time, the engine speed at which the measurement of compression pressure is made should be checked because the compression pressure varies with engine rpm. The engine rpm can be measured at the front end of the crankshaft.

Measuring Compression Pressure

To check the compression pressure, see *COMPRESSION TEST* under *ENGINE ADJUSTMENTS*.

NOTE: Do not guess the conditions of other cylinders from a result of testing one cylinder. Be sure to measure the compression pressure for each cylinder. Look for cylinders with dramatically (at least 20%) lower compression than the average of the other cylinders. If the weak cylinder is flanked by healthy cylinders, the problem is either valve- or head-gasket related. Very low compression in an adjacent cylinder indicates gasket failure. Abnormally high readings on all cylinders indicate heavy carbon accumulations, a condition that might be accompanied by high pressures and noise.

NOTE: In case of severe vibrations and detonation noise, have the injectors overhauled by an authorized fuel injection service center. Poor fuel quality, contaminates, and loss of positive fuel pressure to the injection pump will result in injector faults.

OVERHAUL CONDITIONS

Compression pressure tends to increase a little in a new engine until the piston rings and valve seats have been broken in. Thereafter, it decreases gradually with the progressive wear of these parts. Engine compression should be 30 kg/cm² (at 200 rpm).

When the decrease of compression pressure reaches its limit (see *SERVICE STANDARDS*), the engine must be overhauled. The engine also requires an overhaul when oil consumption is high, when blowby is evident, and when compression values are at minimum or below.

NOTE: Refer to the *SERVICE STANDARDS* chart during an engine overhaul. It gives the measurements and values for the repair or replacement of the engine components.

ENGINE TROUBLESHOOTING

The following troubleshooting table describes certain problems relating to engine service, the probable causes of these problems, and the recommendations to overcome these problems.

Note: The engine's electrical system is protected by a 20-ampere manual reset circuit breaker. The preheat solenoid is mounted on the same bracket.

PROBLEM	PROBABLE CAUSE	VERIFICATION/REMEDY
HARD STARTING	LOW CRANKING SPEED 1. Engine oil viscosity too high. 2. Run-down battery. 3. Worn battery. 4. Battery terminals loosely connected. 5. Defective starter. 6. Defective main drive section.	1. Replace engine oil with less viscous oil. 2. Recharge battery. 3. Replace battery. 4. Clean terminals and correct cables. 5. Repair or replace starter. 6. Check clutch for disengagement.
	DEFECTIVE INJECTION SYSTEM 1. Air trapped in fuel passage. 2. Clogged fuel filter. 3. Low injection pressure. 4. Inadequate spray. 5. Injection pump delivering insufficient fuel. 6. Injection too early.	1. Bleed air from fuel system. 2. Clean or replace filter. 3. Adjust injection pressure. 4. Clean or replace nozzle. 5. Repair or replace injection pump. 6. Adjust injection timing.
	ENGINE TROUBLES 1. Low compression. a. Incorrect valve clearance. b. Inadequate contact of valve seat. c. Valve stem seized. d. Broken valve spring. e. Compression leaks through cylinder head gasket. f. Cracked or distorted cylinder head. g. Piston ring seized. h. Worn piston ring and cylinder. i. Cracked or worn piston. 2. Burnt glow plug. 3. Faulty glow plug operation. 4. Incorrect governor lever position. 5. Governor spring out of position.	a. Adjust valve clearance. b. Lap valve. c. Replace valve and valve guide. d. Replace valve spring. e. Replace gasket. f. Replace cylinder head. g. Replace piston and piston ring. h. Overhaul engine. i. Replace piston. 2. Replace glow plug. 3. Check glow plugs and solenoid. 4. Set lever to starting position. 5. Correct spring.
POOR IDLING	1. Improper valve clearance. 2. Poor valve to valve seat contact. 3. Failure of cylinder head gasket. 4. Malfunction of fuel system.	1. Adjust valve clearance. 2. Repair or replace. 3. Replace gasket. 4. See <i>LOW OUTPUT</i> and <i>ROUGH OPERATION</i> .
LOW OUTPUT	LOW COMPRESSION	See <i>Low Compression</i> under <i>HARD STARTING</i> .
	INJECTION SYSTEM OUT OF ADJUSTMENT 1. Incorrect injection timing. 2. Insufficient injection. 3. Low injection pressure.	1. Adjust injection timing. 2. Repair or replace injection pump. 3. Check injection nozzle and adjust pressure.
	INSUFFICIENT FUEL 1. Air trapped in fuel system. 2. Clogged filter. 3. Contaminated fuel tank.	1. Check and retighten connector. 2. Clean or replace filter. 3. Clean tank.
	INSUFFICIENT INTAKE AIR 1. Clogged air cleaner.	1. Clean or replace air cleaner.

(continued)



ENGINE TROUBLESHOOTING

PROBLEM	PROBABLE CAUSE	VERIFICATION/REMEDY
LOW OUTPUT (cont.)	OVERHEATING 1. Low coolant level. 2. Loose V-belt. 3. Incorrect injection timing. 4. Low engine oil level.	1. Add coolant. 2. Adjust or replace V-belt. 3. Adjust injection timing. 4. Add engine oil.
EXCESSIVE OIL CONSUMPTION	OIL LEAKAGE 1. Defective oil seals. 2. Loose oil filter. 3. Broken cylinder head cover gasket. 4. Damaged cylinder head cover. 5. Damaged front housing gasket. 6. Loose oil pipe connector. 7. Loose bolt(s) at oil pump body, cylinder head covers or oil pan. 8. Loose or damaged oil pressure switch. 9. Defective seal at oil pan and cylinder block. 10. Loose drain plug.	1. Replace oil seals. 2. Tighten. 3. Replace gasket. 4. Replace. 5. Replace. 6. Retighten oil connections. 7. Tighten. 8. Tighten or replace. 9. Repair. 10. Retighten or replace.
	OIL LEVEL RISING 1. Incorrectly positioned piston ring gaps. 2. Displaced or twisted connecting rod. 3. Worn piston ring. 4. Worn piston or cylinder.	1. Correct ring gap positions. 2. Replace connecting rod. 3. Replace ring. 4. Replace piston and rebore cylinder.
	OIL LEVEL FALLING 1. Defective stem seal. 2. Worn valve and valve guide.	1. Replace stem seal. 2. Replace valve and valve guide.
OIL PRESSURE DROP	1. Oil leak. 2. Insufficient oil. 3. Worn and/or damaged oil pump gear. 4. Worn oil pump plunger or weak spring. 5. Clogged oil strainer. 6. Excessive lubrication clearance between main bearing and connecting rod bearing.	1. See <i>OIL LEAKAGE</i> . 2. Add oil. 3. Replace. 4. Replace. 5. Clean. 6. See <i>Crankshaft Assembly</i> under <i>ENGINE REASSEMBLY</i> .
EXCESSIVE FUEL CONSUMPTION	ENGINE BODY TROUBLES 1. Noisy knocking. 2. Smoky exhaust. 3. Moving parts nearly seized or excessively worn. 4. Poor compression. 5. Improper valve timing. 6. Improper valve clearance.	1. See <i>KNOCKING</i> . 2. See <i>SMOKY EXHAUST</i> . 3. Repair or replace. 4. See <i>Low compression</i> under <i>HARD STARTING</i> . 5. Adjust. 6. Adjust.
	INSUFFICIENT INTAKE AIR 1. Air intake obstructed.	1. Clean and remove obstruction.
	NOZZLE TROUBLES 1. Seized nozzle. 2. Worn nozzle.	1. Replace. 2. Replace.
	IMPROPER FUEL FUEL LEAKS	Replace with proper fuel. Find fuel leaks.
SMOKY EXHAUST	WHITISH OR PURPLISH 1. Excessive engine oil. 2. Excessive rise of oil into combustion chamber. <ul style="list-style-type: none"> a. Poor piston contact. b. Seized piston ring. c. Excessive piston-to-cylinder clearance. 	1. Correct oil level. <ul style="list-style-type: none"> a. Check. b. Replace or clean. c. Replace or correct.

(continued)



ENGINE TROUBLESHOOTING

PROBLEM	PROBABLE CAUSE	VERIFICATION/REMEDY
SMOKY EXHAUST (cont.)	WHITISH OR PURPLISH (cont.) d. Worn valve stem and valve guide. e. Low engine oil viscosity. f. Excessive oil pressure. 3. Injection timing is too late. 4. Insufficient compression.	d. Replace. e. Replace. f. Correct. 3. Adjust. 4. See <i>Low compression</i> under <i>HARD STARTING</i> .
	BLACKISH OR DARK GRAYISH 1. Engine body troubles. a. Poor compression. b. Improper valve clearance. 2. Insufficient intake air (air cleaner clogged). 3. Improper fuel.	a. See <i>Low compression</i> under <i>HARD STARTING</i> . b. Adjust. 2. Clean air cleaner. 3. Replace with proper fuel.
ABNORMAL SOUND OR NOISE	CRANKSHAFT AND MAIN BEARING 1. Main bearing worn, heat-damaged or seized. 2. Excessive main bearing oil clearance. 3. Melted main bearing. 4. Badly worn crankshaft. 5. Excessive crankshaft end play.	1. Replace bearing and grind crankshaft. 2. Replace bearing. 3. Replace bearing and check lubrication system. 4. Grind crankshaft. 5. Adjust end play.
	CONNECTING ROD AND CONNECTING ROD BEARING 1. Connecting rod big end bearing worn, heat-damaged or seized. 2. Worn crankpin. 3. Bent connecting rod.	1. Replace bearing. 2. Grind crankshaft. 3. Correct bend or replace.
	PISTON, PISTON PIN, AND PISTON RING 1. Worn cylinder. 2. Worn piston or piston pin. 3. Piston seized. 4. Piston seized and rings worn or damaged. 5. Bent connecting rod.	1. Rebore cylinder to oversize and replace piston. 2. Replace piston. 3. Replace piston and rebore cylinder. 4. Replace piston and rings. 5. Replace connecting rod.
	VALVE MECHANISM 1. Worn camshaft. 2. Excessive valve clearance. 3. Broken valve spring. 4. Worn timing gear.	1. Replace camshaft. 2. Adjust valve clearance. 3. Replace valve spring. 4. Replace timing gear.
	OTHER 1. Fresh water pump bearing malfunction. 2. Incorrect drive belt tension. 3. Alternator bearing malfunction. 4. Exhaust gas leakage. 5. Timing belt tensioner malfunction.	1. Replace bearing. 2. Adjust. 3. Replace bearing. 4. Repair. 5. Replace tensioner.
ROUGH OPERATION (HUNTING)	INJECTION PUMP SYSTEM 1. Uneven injection. 2. Control rack malfunctioning. 3. Worn delivery valve. 4. Inadequate injection nozzle spray.	1. Adjust injection or replace parts. 2. Disassemble, check and correct injection pump. 3. Replace delivery valve. 4. Replace injection nozzle.
	GOVERNING SYSTEM 1. Governor lever malfunctioning. 2. Fatigued governor spring.	1. Check governor shaft and correct operation. 2. Replace spring.

(continued)



ENGINE TROUBLESHOOTING

PROBLEM	PROBABLE CAUSE	VERIFICATION/REMEDY
KNOCKING	ENGINE KNOCKS WITHOUT MUCH SMOKE 1. Engine troubles. a. Overheated cylinder. b. Carbon deposits in cylinder. 2. Too early injection timing. 3. Too high injection pressure. 4. Improper fuel.	a. See <i>OVERHEATING; LOW OUTPUT</i> . b. Clean. 2. Correct. 3. Correct. 4. Replace with proper fuel.
	KNOCKING WITH DARK SMOKE 1. Poor compression. 2. Injection pump malfunctioning. a. Worn plunger. b. Pinion is not in mesh with control rack. c. Broken delivery valve spring. d. Worn delivery valve seat. 3. Improper nozzle. a. Poor spray. b. Poor chattering. c. After-injection drip. d. Nozzle needle valve seized.	1. See <i>Low compression</i> under <i>HARD STARTING</i> . a. Replace. b. Correct. c. Replace. d. Replace. a. Clean or replace nozzle. b. Repair or replace nozzle. c. Repair or replace nozzle. d. Replace.
INTERMITTENT EXHAUST SOUND	1. Fuel filter clogged. 2. Fuel pipe sucks air. 3. Water mixed in fuel	1. Clean or replace. 2. Retighten pipe joints or replace pipe. 3. Replace fuel.
OVERHEATING	1. V-belt slackening or slippery with oil. 2. Damaged water pump. 3. Lack of coolant. 4. Low oil level or poor oil quality. 5. Knocking. 6. Moving parts seized or damaged.	1. Adjust, replace or clean. 2. Replace. 3. Add. 4. Add or change. 5. See <i>KNOCKING</i> . 6. Replace.



ENGINE DISASSEMBLY

NOTE: Before disassembly and cleaning, carefully check for defects which cannot be found after disassembly and cleaning.

GENERAL DISASSEMBLY PROCEDURE

- All disassembled parts should be carefully arranged in the order of reassembly. Mark or label the parts as needed to insure proper mating and reassembly in the proper directions and positions.
- If the disassembly procedure is complex requiring many parts to be disassembled, the parts should be disassembled in a way that will allow them to be efficiently reassembled without any change in the engine's external appearance or its performance.
- Do not remove or disassemble parts that require no disassembly.
- Carefully inspect each part after removal for damage, deformation, and other problems.
- Be careful not to damage the disassembled parts. Keep the parts clean.
- Use the proper tools. Apply oil when necessary. Take special care to keep the fuel system parts free from the intrusion of dust and dirt.
- Remove the transmission first, then disassemble the engine.

TRANSMISSION REMOVAL

1. Unplug the instrument panel wiring harness.
2. Drain the transmission fluid and the transmission oil cooler hoses
3. Detach the oil cooler hoses.
4. Unbolt the transmission from the engine.

NOTE: For transmission service and maintenance, refer to your transmission owner's manual. To rebuild a transmission, contact your WESTERBEKE dealer or a qualified marine transmission service facility.

ENGINE DISASSEMBLY

1. Clean the exterior of the engine of any deposits of dirt and oil.
2. Mount the engine on a suitable engine stand for disassembly.
3. Drain the coolant from the engine and the heat exchanger. Drain the fuel and the engine oil.
4. Remove the engine wiring harness in its entirety. Label the terminal connections to insure proper reattachment.
5. Remove the engine heat exchanger and the engine oil cooler/oil filter assembly. If possible, leave one end of each hose connection attached to the part being removed.
6. Remove the starter motor.
7. Remove the engine bellhousing.
8. Remove the transmission damper plate.

9. Remove the flywheel.
10. Remove the engine back plate.
11. Unclamp the exhaust elbow, the two coolant hoses on the exhaust manifold, and the coolant recovery tank hose, then remove the intake/exhaust manifold in its entirety with its four gaskets.

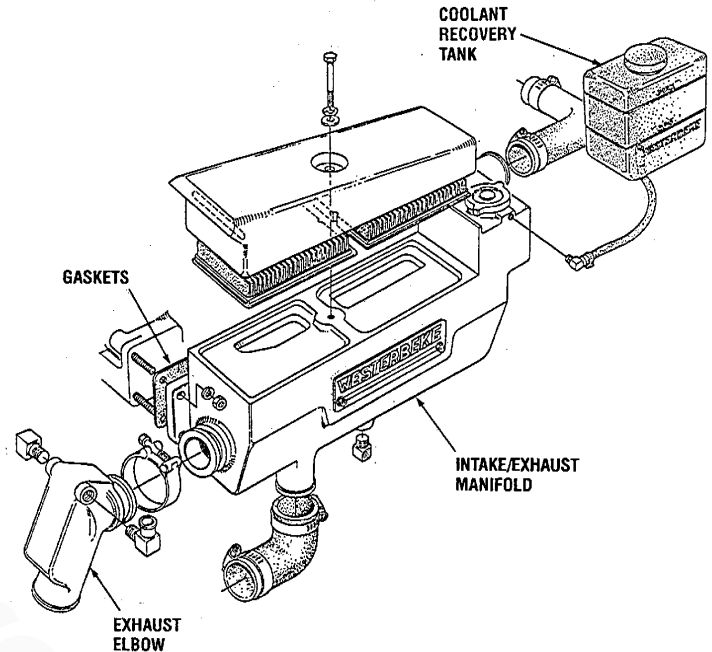

12. Remove the alternator.
13. Remove the raw water pump.
14. Remove the engine mounted fuel filter and the fuel line to the injection pump. (Note the arrangement of the sealing washers on the banjo bolts at the fuel filter and the injection pump). Remove the fuel lift pump.
15. Remove the thermostat housing, gasket, and the thermostat. Leave the temperature sending unit in place.

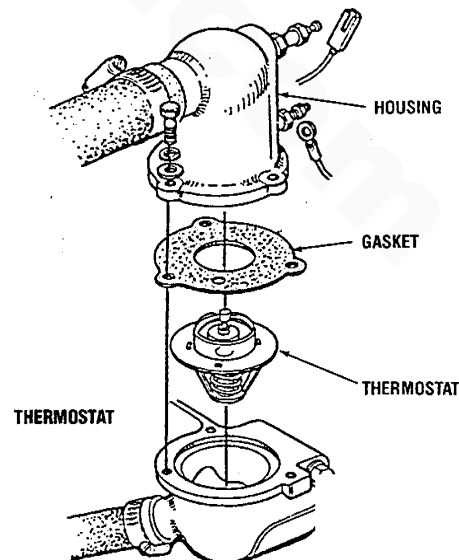

ENGINE DISASSEMBLY

16. Remove the idler pulley bracket and idler pulley.
17. Remove the seal plate.
18. Remove the coolant pump.
19. Remove all the high pressure injector lines from the injection pump to the injectors. Leave the two upper line clamps in place.
NOTE: Cap the ends of the lines, and the connections at the injection pump and at the injectors, to prevent entry of foreign material.
20. Remove the fuel return lines from the top of the injectors and from the fuel injection pump. (Note the washer arrangement on the fuel return line banjo bolts. Cap all openings on the fuel return line, injectors and injection pump.)
21. Remove the fuel injectors, dust seals and sealing washers from the cylinder head.
22. Remove the glow plugs.
23. Remove the cylinder head cover.
24. Fuel Injection Pump.

NOTE: The fuel injection pump is a very important component of the diesel engine, requiring the utmost care in handling. It has been thoroughly bench-tested, and the owner/operator is cautioned not to attempt to service it. If the fuel injection pump requires servicing, remove it and take it to an authorized fuel injection pump service facility. Do not attempt to disassemble and repair it. If the pump is defective, WESTERBEKE recommends that you replace the entire pump.

The only adjustment the servicing mechanic should make to the fuel injection pump is the adjustment for engine idle speed (see IDLE SPEED ADJUSTMENT under ENGINE ADJUSTMENTS).

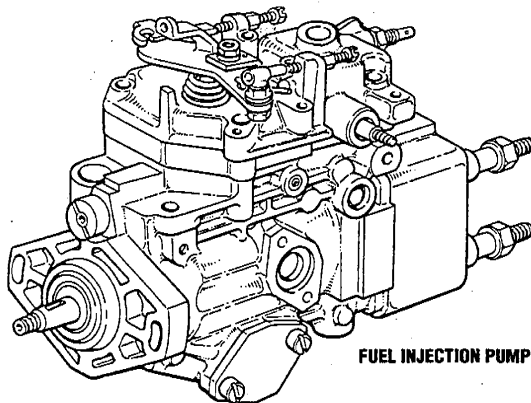

Remove the injection pump as follows:

NOTE: Scribe mating marks on the pump body flange and the timing belt cover before removal.

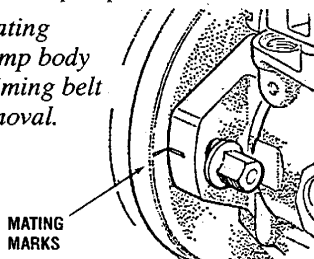

- a. Remove the two timing belt covers.
- b. Loosen the two injection pump hold-down nuts. Do not remove them entirely. The hold-down nut on the engine side of the pump can be loosened by using a 1/4" universal socket and extension with a ratchet.
- c. Remove the nut and lockwasher from the injection pump shaft.
- d. Place the keyway on the injection pump shaft in the 12 o'clock position using the front crankshaft pulley bolt before attempting to remove the injection pump.
- e. Using the **pulley puller** (49 S120 215A), apply sufficient pressure to loosen the pump from the pulley. The loose hold down nuts will prevent the pump from falling from the engine.

NOTE: If an extractor is not available, replace the nut loosely on the injection pump shaft, and with a nylon drift and hammer, gently tap the injection pump shaft to dislodge it from the keyed pulley.

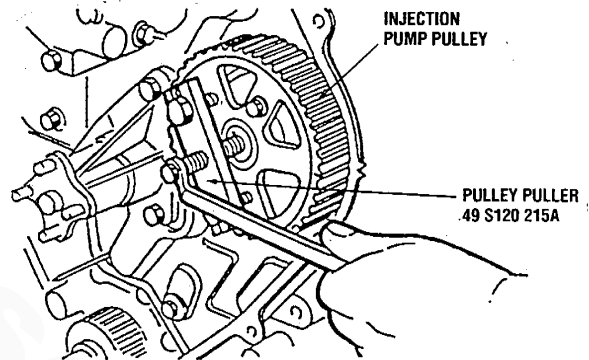

- f. Once loosened, remove the hold down nuts and washers and carefully withdraw the pump from the pulley and the engine.
25. Remove the following components:
 - a. Oil pressure switch and oil level gauge.
 - b. Dipstick tube.
 - c. Cylinder head cover.
 - d. Crankshaft pulley.
 - e. Oil strainer and oil pan.
 - f. Oil pump assembly.
 - g. Rear cover.
 - h. Connecting rod caps.
 - i. Pistons and connecting rods.
 - j. Piston rings.
 - k. Main bearing caps.
 - l. Main bearings.
 - m. Oil jets.
 - n. Crankshaft.



ENGINE DISASSEMBLY

Timing Belt

NOTE: WESTERBEKE recommends replacing the timing belt during an engine overhaul. Timing belt failure could result in major damage to the engine.

NOTE: If the timing belt is to be reused, draw an arrow on the belt pointing in the direction of the belt's rotation so it will be replaced in the same direction.

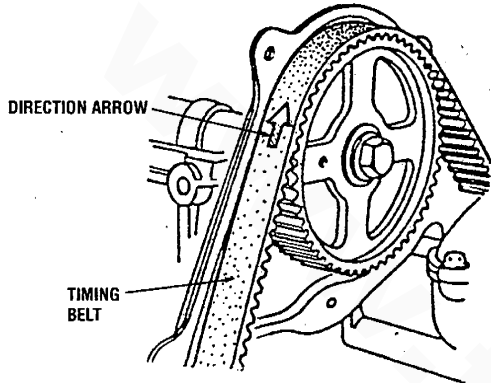

1. Loosen the timing belt tensioner lock bolt, push the timing belt tensioner left as far as it will go, then temporarily retighten the lock bolt.

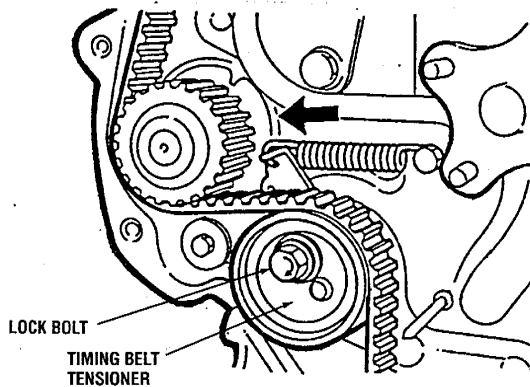

2. Remove the timing belt.
3. Remove the timing belt tensioner.
4. Turn the crankshaft clockwise about 45° from the timing mark which is marked on the oil pump housing.

NOTE: Turning the crankshaft prevents the pistons and valves from contacting one another.

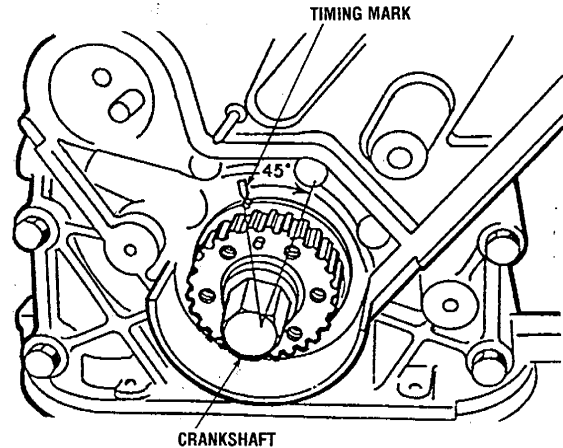

Injection Pump Pulley

1. Put two bolts (size M8 x 1.25 x 35 – 40 mm) through the arms of the injection pump pulley and insert them in the thread hole of the injection pump bracket.

NOTE: This is to prevent the injection pump pulley from turning while loosening the injection pump pulley lock bolt.

2. Loosen the injection pump pulley lock bolt.

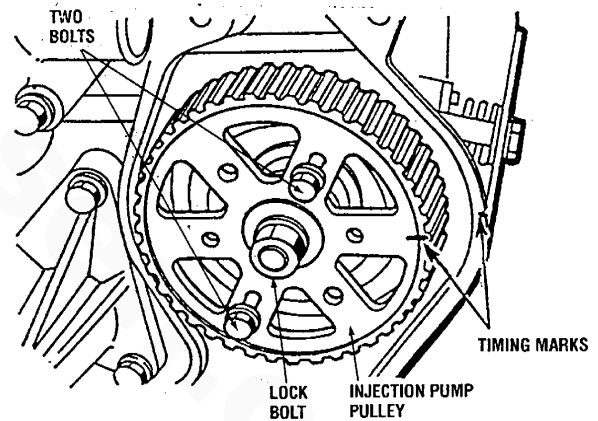

3. Using the pulley puller (49 S120 215A), separate the injection pump pulley from the injection pump shaft.

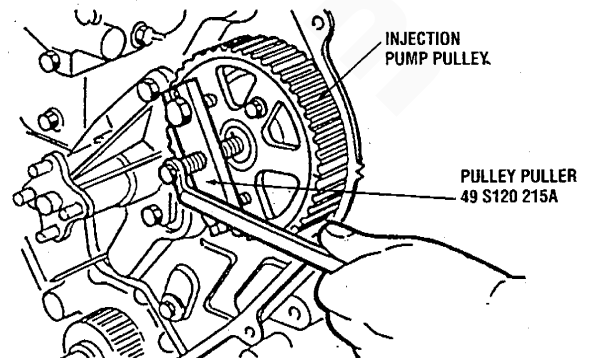

ENGINE DISASSEMBLY

Camshaft Pulley & Timing Belt Pulley

1. Hold the camshaft with a wrench (29 mm, 1.1 in) and loosen the camshaft pulley lock bolt.

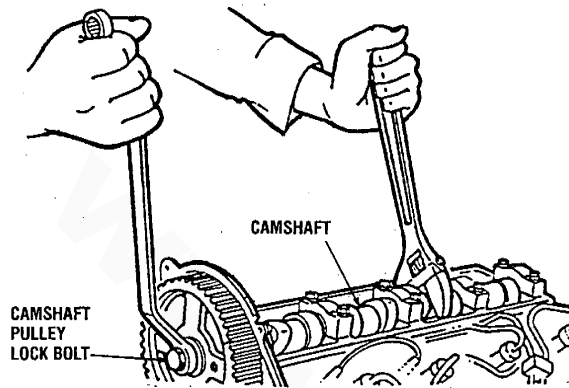

CAUTION: Do not damage the edge of the cylinder head with the wrench. If it is damaged, engine oil may leak.

CAUTION: Before removing the camshaft pulley, turn the crankshaft 45° clockwise to prevent damage to the valves.

2. Remove the camshaft pulley from the camshaft using the same procedure described under *Injection Pump Pulley*, above.

CAUTION: Do not hit the camshaft pulley with a hammer.

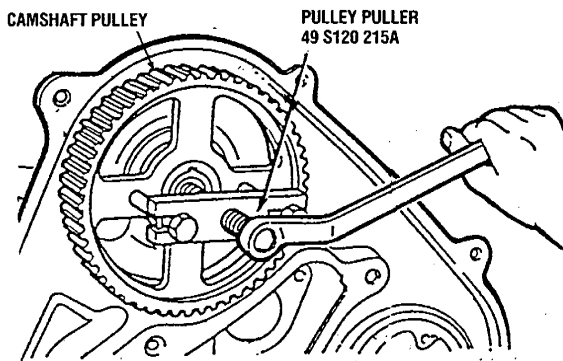

3. Remove the timing belt pulley.

Cylinder Head Bolts

1. Loosen the cylinder head bolts in the numbered sequence shown in the illustration. Loosen them a little at a time, in sequence.

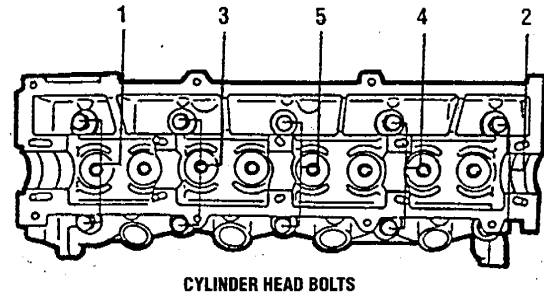

Cylinder Head and Gasket

1. Remove the cylinder head by tapping it with a plastic hammer.
2. Remove the cylinder head gasket.

Camshaft

1. Gradually loosen the camshaft cap nuts in the numbered sequence shown in the illustration.
2. Remove the caps.
3. Remove the camshaft and oil seals.

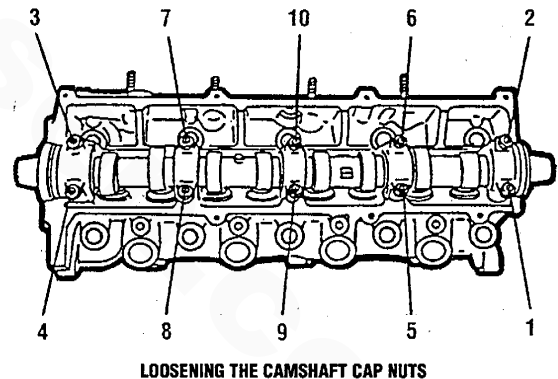

Adjusting Discs and Tappets

1. Remove the adjusting discs and tappets as a set.

CAUTION: All adjusting discs and tappets should be disassembled in a way that correct reassembly can be performed efficiently.

ENGINE DISASSEMBLY

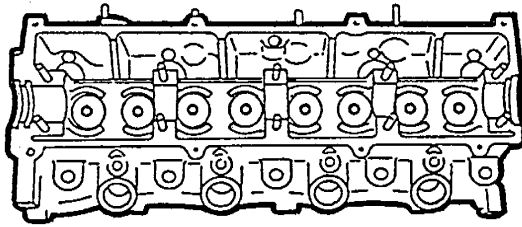

ADJUSTING DISCS AND TAPPETS

Valves

1. Remove the springs.
2. Remove the valves, lower spring seats and spring retainers from the cylinder head by using an appropriate valve spring compression tool.

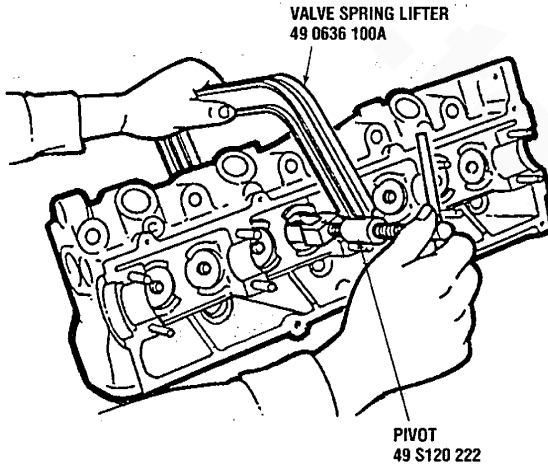

NOTE: The valve guides are to be removed only after measuring the valve guide/valve stem (see Valve Guides under ENGINE INSPECTION).

Valve Seals

1. Move the piston of the valve seal to be replaced to approximately top dead center.
2. After removing the lower spring seats, remove the valve seals by using the valve seal remover (49 S120 170) to grasp and work them out.

NOTE: The valve seal remover (49 S120 170) cannot grasp the valve seals unless the lower spring seats have been removed.

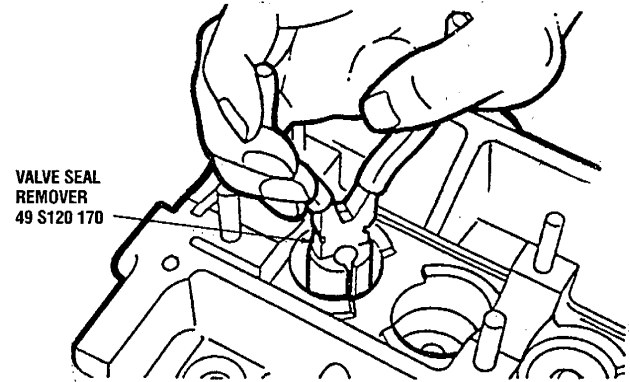

Combustion Chamber Inserts

1. Remove the combustion chamber inserts from the bottom surface of the cylinder head by using a suitable mandrel.

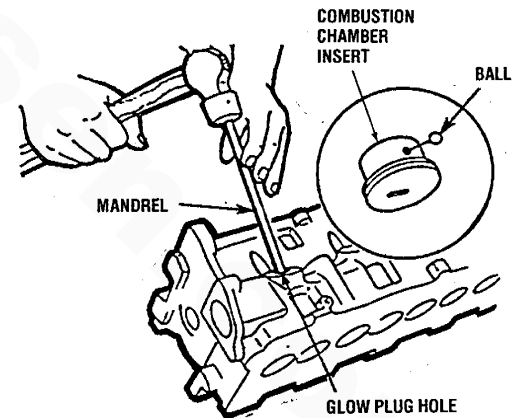

ENGINE INSPECTION AND REPAIR

GENERAL INSPECTION PROCEDURE

1. Before inspection, clean each part taking care to remove any gasket fragments, dirt, oil or grease, carbon, moisture residue, or other foreign materials.
2. Be careful not to damage the joints or sliding parts of aluminum alloy components such as the cylinder head and the pistons.
3. Inspection and repair should be done in the order indicated.

ENGINE INSPECTION

Cylinder Head

1. Inspect for water leakage, fuel leakage, damage, and cracks. If a problem is found, replace the part.
2. Measure the cylinder head for distortion in six directions using a thickness gauge, as shown in the illustrations.

Distortion limit: 0.10 mm (0.004 in)

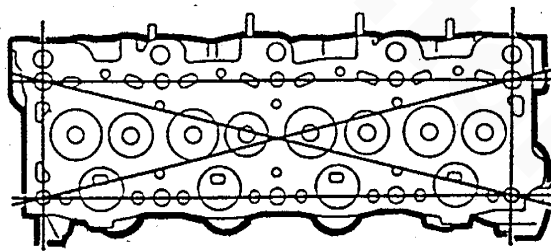

CYLINDER HEAD DISTORTION

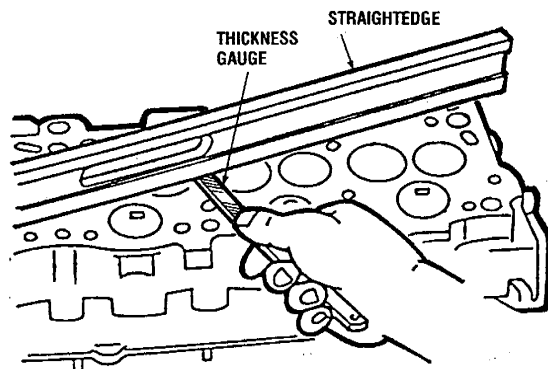

CYLINDER HEAD DISTORTION

3. If cylinder head distortion exceeds the limit, replace the cylinder head.

CAUTION: Do not attempt to repair the cylinder head by milling or grinding. Handle the cylinder head carefully, taking special care not to damage its lower surface.

4. Measure the manifold contact surface distortion in the three directions shown in the illustration. If the distortion exceeds the limit, grind the surface, or replace the cylinder head.

Distortion limit: 0.20 mm (0.008 in)

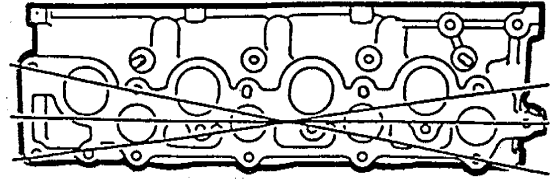

MANIFOLD CONTACT SURFACE DISTORTION

5. Measure the oil clearance of the camshaft.
 - a. Remove the tappets and adjusting discs from the cylinder head, and separate them by cylinder.

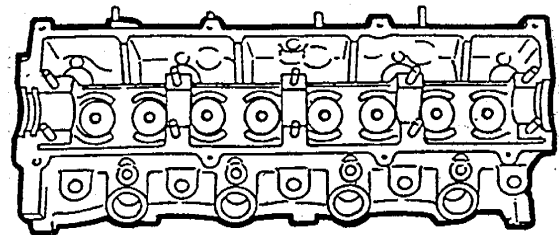

TAPPETS AND ADJUSTING DISCS REMOVAL

- b. Clean away oil and dirt from the camshaft and cylinder head journals.
- c. Set a plastigauge on the camshaft journal (in the axial direction of the journal).
- d. Set the camshaft caps, and tighten the nuts to the specified torque.

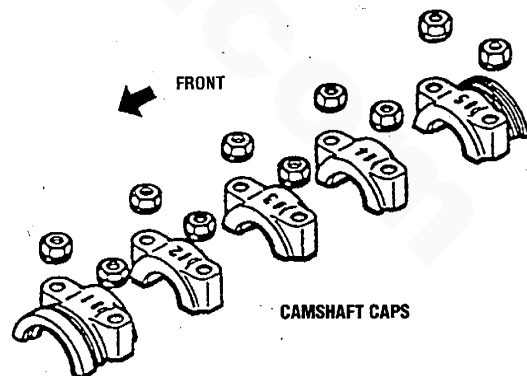

CAMSHAFT CAPS

Camshaft cap nut tightening torque:
2.0 – 2.7 kg-m (15 – 20 ft-lb)

ENGINE INSPECTION AND REPAIR

⚠ CAUTION: When installing the camshaft caps, note the correct sequence and the arrow marks. When tightening the camshaft cap nuts, do so evenly and in the sequence shown in the illustration.

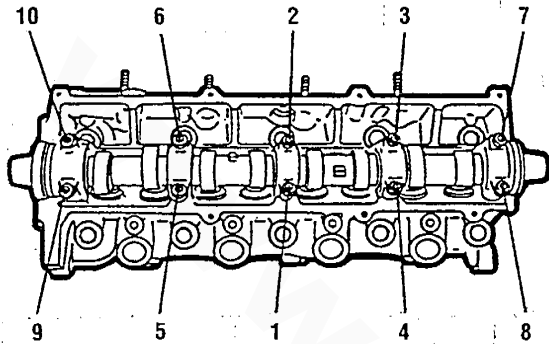

TIGHTENING THE CAMSHAFT CAP NUTS

- e. Remove the camshaft caps and measure the oil clearance.

Standard oil clearance:

0.025 – 0.066 mm (0.0098 – 0.0260 in)

Limit: 0.1 mm (0.0039 in)

- f. If the oil clearance exceeds the limit, replace the cylinder head or the camshaft.

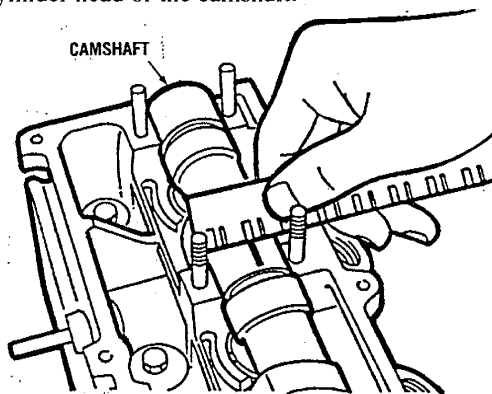

MEASURING THE OIL CLEARANCE

6. Measure the end play of the camshaft. If the end play exceeds the limit, replace the camshaft or the cylinder head.

Standard camshaft end play:

0.02 – 0.15 mm (0.00079 – 0.00591 in)

Limit: 0.2 mm (0.0079 in)

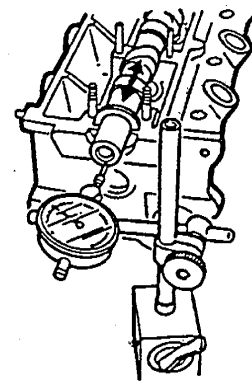

MEASURING THE CAMSHAFT END PLAY

7. Measure the amount that the combustion chamber insert has receded.

- a. Clean the lower side so that the surface of the combustion chamber insert won't be scarred.
b. Measure using a dial gauge.

Limits:

Receded amount: 0.04 mm (0.0016 in)

Projection amount: 0.05 mm (0.0024 in)

- c. If either limit is exceeded, replace the combustion chamber insert or the cylinder head.

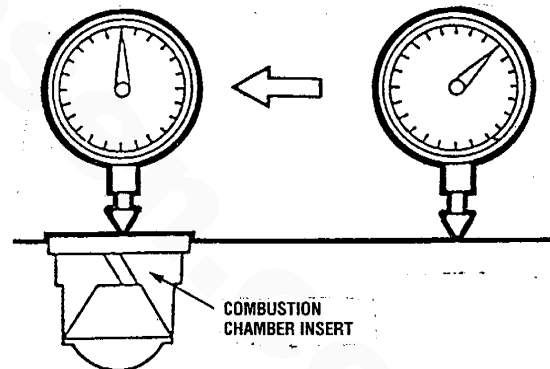

Valve Seats

1. Use a thickness gauge and a straightedge, as shown in the illustration, to measure the amount the valve has receded from the cylinder head surface.

ENGINE INSPECTION AND REPAIR

If the receded amount is **1.55 – 2.55 mm (0.061 – 0.100 in)**, use an equivalent washer at the valve spring seat. If the receded amount is **2.55 mm (0.100 in)** or more, replace the cylinder head

Standard amount of valve recession
Intake and exhaust (cold engine):
0.75 – 1.05 mm (0.030 – 0.041 in)

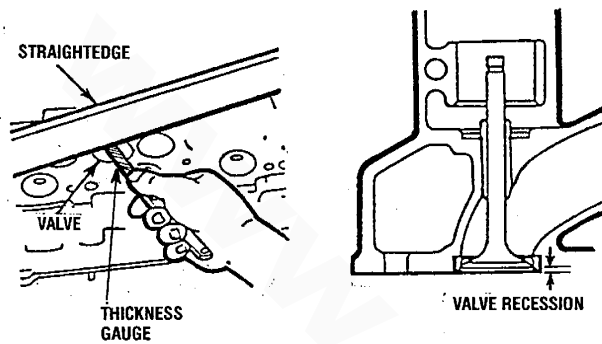

2. Check the surface which contacts the valve face for roughness or damage. If necessary, use a valve seat cutter or valve seat grinder to repair to the specified shape.

NOTE: To check the contact width, apply a thin coating of red lead to the valve seat, and press the valve against the valve seat. Be sure not to turn the valve when doing so.

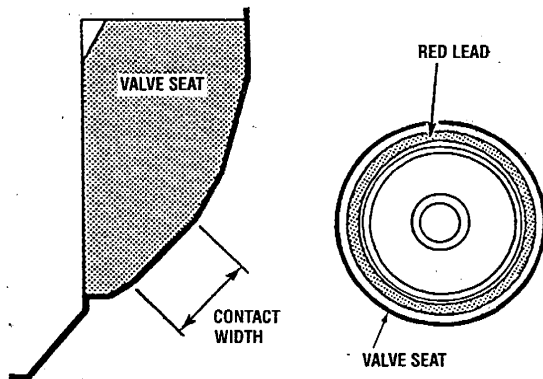

NOTE: When grinding the valve seat, use a 15°, 45° or 60° valve seat cutter or valve seat grinder to grind away the roughness and/or scars (to the minimum limit) of the seat surface, always checking the contact width and contact position while grinding.

Standard valve seat contact width:
1.7 – 2.3 mm (0.067 – 0.091 in)

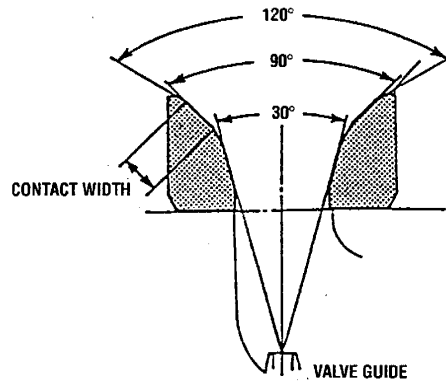

3. To seat the valve, apply a thin coating of engine oil mixed with a small amount of compound to the seat surface, then lightly tap while turning the valve.

CAUTION: When seating the valve, be careful not to let compound adhere to the valve stem. The valve contact position in relation to the valve seat must be at the center of the circumference, and the contact width must be the standard value. Check to be sure that the amount of valve recession is within the specification.

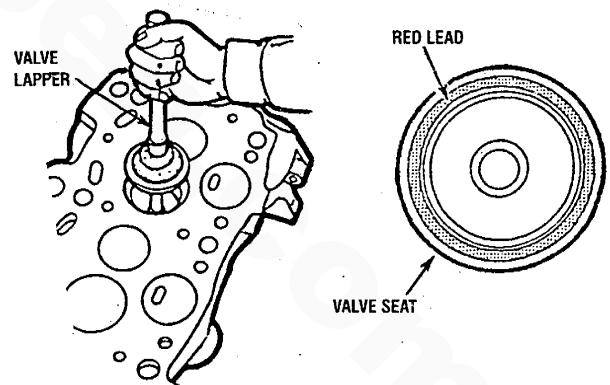

Valves

1. Inspect each valve and replace any that show valve stem wear, damage, bending, or dents.

ENGINE INSPECTION AND REPAIR

2. Inspect each valve for roughness or damage on its faces. If the problem is slight, repair the valve with a valve refacer.

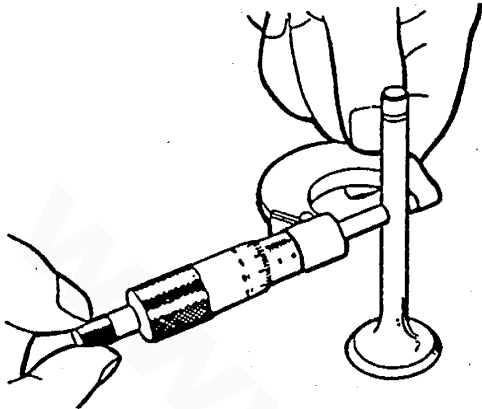

2. To replace the valve guide, tap it to the side opposite the combustion chamber using the valve guide remover (49 0636 165A).

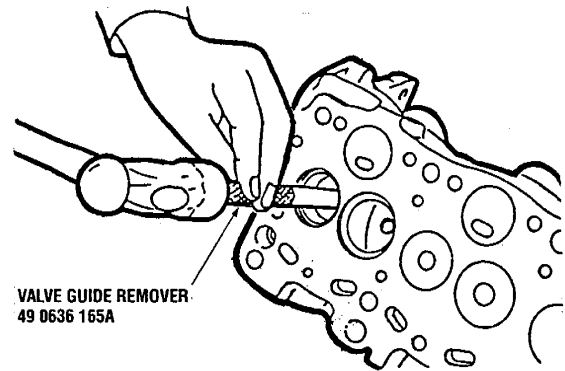

Standard valve stem diameter:

Intake: 7.970 – 7.985 mm (0.3138 – 0.3144 in)

Exhaust: 7.965 – 7.980 mm (0.3136 – 0.3142 in)

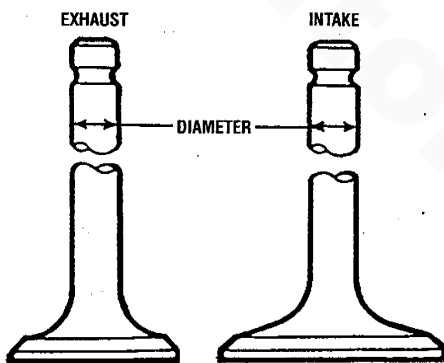

To install, fit the clip onto the valve guide. Use the valve guide installer (49 0552 165) to tap the valve guide in from the side opposite the combustion chamber until the clip barely contacts the cylinder head.

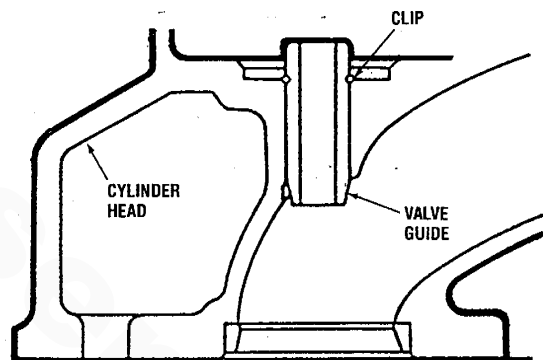

Valve Guides

1. Measure the difference between the inner diameter of each valve guide and the diameter of the corresponding stem. This difference is the stem-to-guide clearance. Replace the valve guide if this clearance exceeds the limit.

Stem-to-guide clearance limit: 0.10 mm (0.004 in)

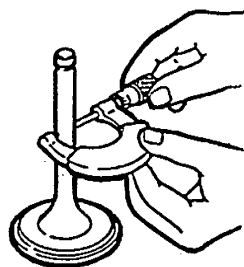
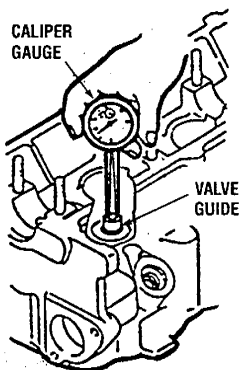

CAUTION: After the valve guide is replaced, recheck the gap between the valve and the valve guide.

The valve seals should be installed after inspection and repair of the valve seats.

Don't confuse the valve guides — intake and exhaust valve guides have different lengths:

The intake valve guide is longer.

The exhaust valve guide is shorter.

ENGINE INSPECTION AND REPAIR

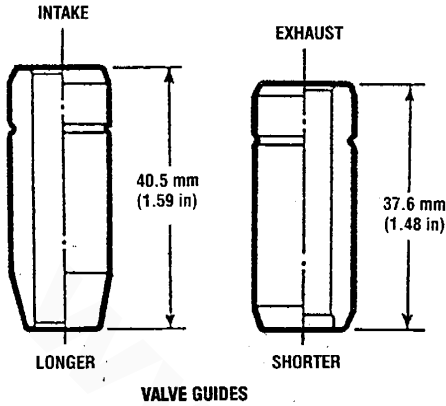

Valve Springs

1. Inspect each valve spring for cracks or other damage. Replace if necessary.
2. Check each spring for free length and angle limit. Replace if necessary

Free length limit: 44.8 mm (1.764 in)

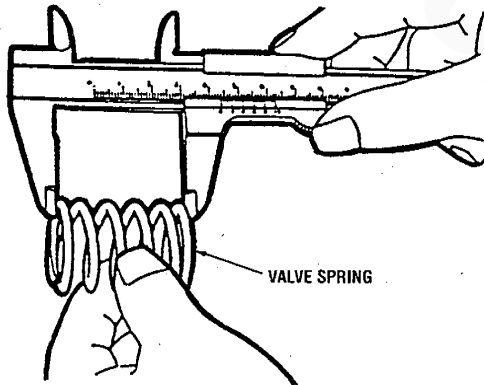

Angle limit: 1.58 mm (0.062 in)

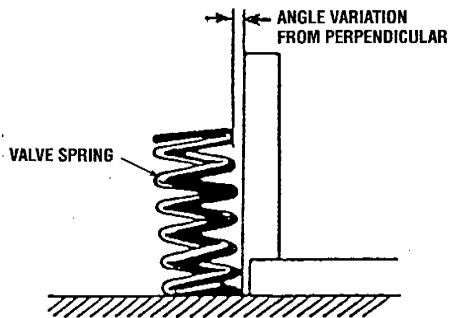

Tappets and Adjusting Discs

1. Measure the outer diameter of the tappet; replace it if the limit is exceeded.
2. Measure the diameter of the tappet hole in the cylinder head, and calculate the difference (clearance) between it and the outer diameter of the tappet; if this clearance is the limit value or more, replace the tappet or the cylinder head.

Standard tappet outer diameter:

34.96 – 34.98 mm (1.3763 – 1.3771 in)

Standard tappet hole:

34.99 – 35.02 mm (1.3776 – 1.3787 in)

Standard clearance:

0.02 – 0.06 mm (0.0008 – 0.0024 in)

Clearance limit: 0.10 mm (0.0040 in)

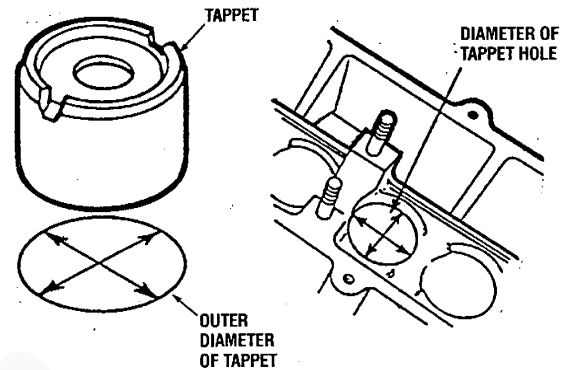

Camshaft

1. Check the camshaft for wear or damage. Replace if necessary.

Standard cam height:

Intake: 44.31 mm (1.744 in)

Exhaust: 45.30 mm (1.783 in)

Cam height limit:

Intake: 43.90 mm (1.728 in)

Exhaust: 44.90 mm (1.768 in)

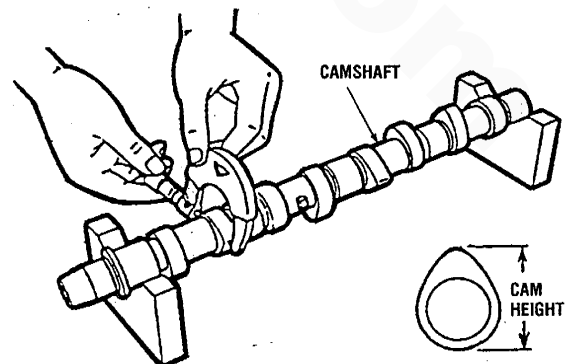

ENGINE INSPECTION AND REPAIR

2. Measure the wear of each journal at the four locations shown in the illustration: directions *A* and *B*, *Front* and *Rear*. Replace the camshaft if necessary.

Journal elliptical limit: 0.05 mm (0.002 in)

Standard journal diameters:

31.96 – 31.98 mm (1.258 – 1.259 in)

Journal diameter limit: 31.86 mm (1.254 in)

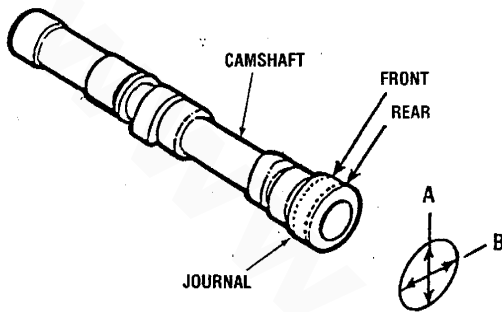

3. Check the camshaft deflection.

Camshaft deflection limit:

0.10 mm (0.0040 in)

NOTE: Place the front and rear journals on V-blocks to make the measurement.

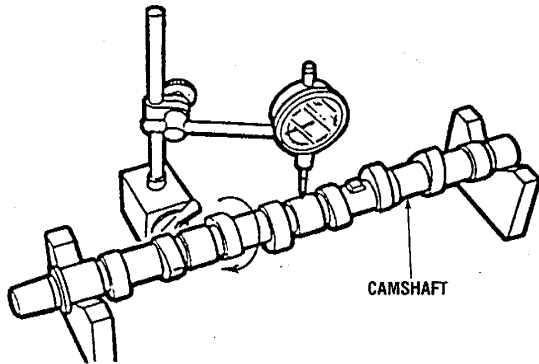

Cylinder Block

1. Check each cylinder for dampness, damage and cracks. Replace if necessary.

2. Measure the distortion (degree of flatness) of the top surface of the cylinder block in six directions using a feeler gauge and a straightedge as shown in the illustrations.

Distortion limit: 0.10 mm (0.0040 in)

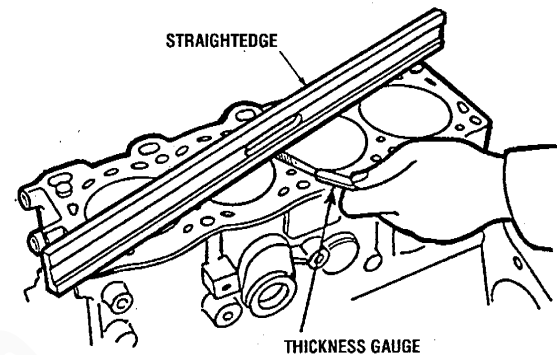
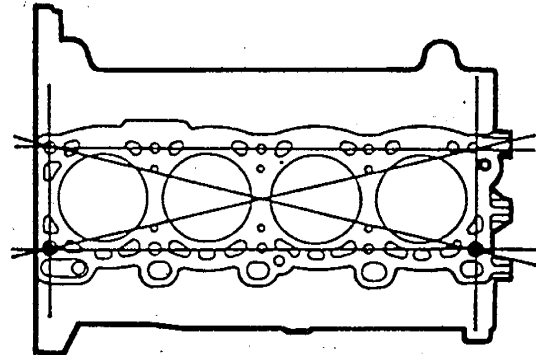

3. If the distortion exceeds the limit, replace the cylinder block.

CAUTION: Don't grind the surface of the cylinder block. If ground, the valves will hit the pistons.

4. Check the cylinder walls for scoring or signs of seizure. If a problem exists, reboring or replacement is necessary.
5. If the upper part of the cylinder wall shows uneven wear, use a ridge reamer to repair.
6. Measure the cylinder diameter at the six locations shown in the illustration. Check the amount of wear. The amount of wear is the difference between the maximum and minimum diameters. If the amount of wear exceeds the limit, the cylinder must be rebored.

Standard cylinder bore: 86.00 mm (3.39 in)

Cylinder bore wear limit: 86.17 mm (3.92 in)

Difference between cylinder bores:

0.022 mm (0.00090 in)

ENGINE INSPECTION AND REPAIR

CAUTION: The boring size should be based on the size of an oversize piston.

Over-size pistons: 0.25 mm (0.010 in)
0.50 mm (0.020 in)

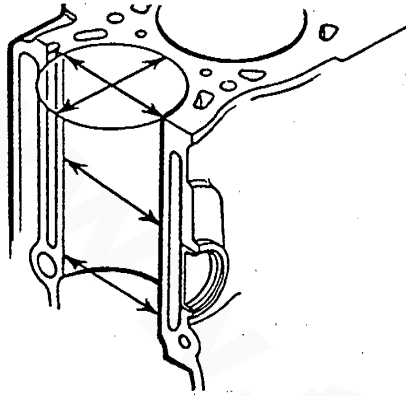

Pistons and Piston Rings

1. Inspect the outer circumferences of all the pistons for seizure or scoring. Replace if necessary.
2. Measure the outside diameter of each piston, and be sure the clearance between the piston and cylinder is correct.

Piston standard outside diameter:

85.95 – 85.98 mm (3.384 – 3.385 in)

Piston and cylinder clearance limit:

0.15 (0.006 in)

CAUTION: Measure the piston outside diameter in the thrust direction, 19 mm (0.75 in) above the bottom of the piston. If the piston is replaced, replace the piston rings also.

Oversize Piston Rings:

0.25 mm (0.010 in), 0.50 mm (0.020 in)

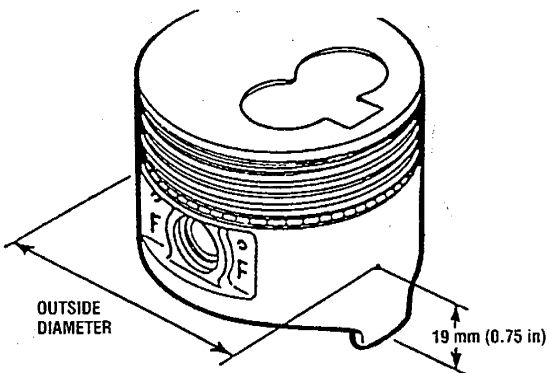

3. Inspect the piston rings for damage, abnormal wear or breakage. Replace if necessary.
4. Insert the piston rings into the cylinder by hand, and push them in by using the piston.
5. Measure the ring opening clearance.

Ring opening clearance limit: 1.0 mm (0.039 in)

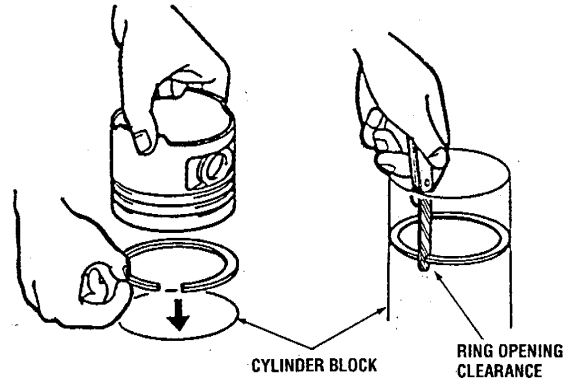

6. Measure the clearance of the piston ring to the ring groove.

Clearance limit: 0.2 mm (0.008 in)

CAUTION: Measure the clearance around the entire circumference of the ring groove.

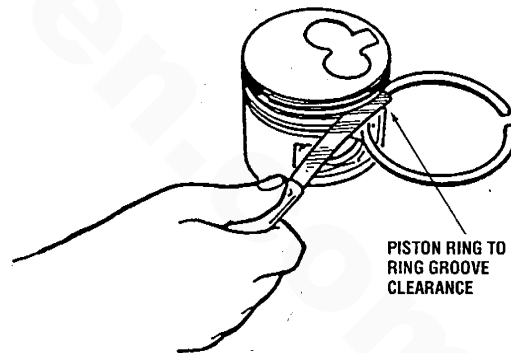

ENGINE INSPECTION AND REPAIR

Connecting Rods

1. Check each connecting rod for bending or torsion.

Connecting rod bending limit:

0.16 mm (0.006 in) per 100 mm (3.94 in)

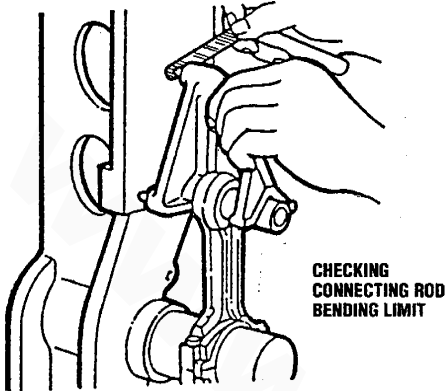

Connecting rod torsion limit:

0.16 mm (0.006 in) per 100 mm (3.94 in)

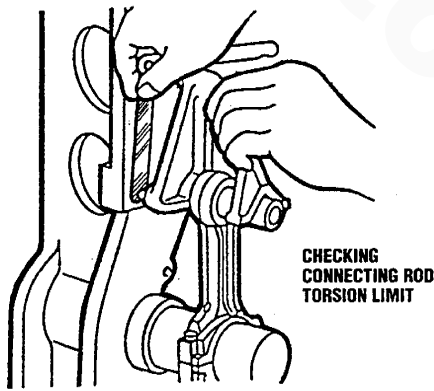

Connecting Rod Bushings

1. Measure the clearance between the outside diameter of the piston pin and the inside diameter of the bushing. If the clearance exceeds the limit, replace the connecting rod bushing.

Standard connecting rod bushing inner diameter:

25.01 – 25.03 mm (0.9846 – 0.9854 in)

Clearance limit: 0.05 mm (0.002 in)

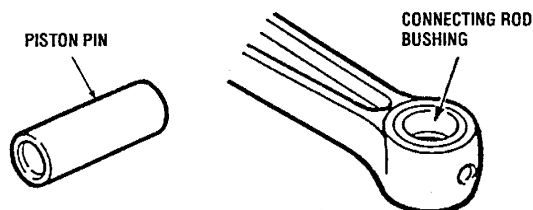

2. To replace the connecting rod bushing, use a press and a suitable pipe (diameter = 27 – 27.5 mm (1.06 – 1.88 in)).

CAUTION: Before assembling, apply a coating of clean engine oil to the connecting rod bushing and connecting rod. Align the oil hole of the connecting rod bushing with the connecting rod oil hole.

3. After pressing the bushing in, correct the bushing's inner diameter by using a spiral expansion reamer, so that the clearance will come within the standard value.

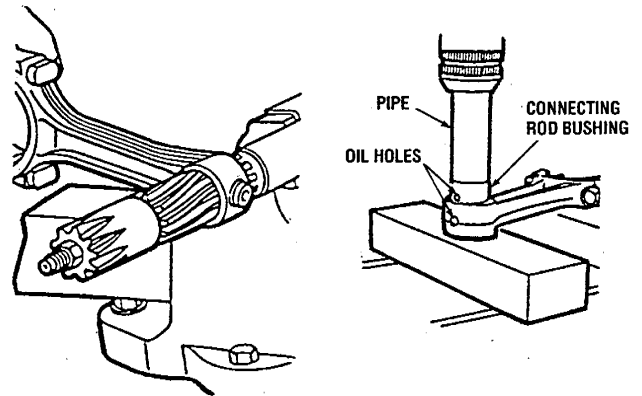

Crankshaft

1. Check around the journals and pins for damage and scoring, and the oil passages for obstructions.
2. Check the crankshaft deflection and each diameter. Replace if necessary.

Deflection limit: 0.05 mm (0.002 in)

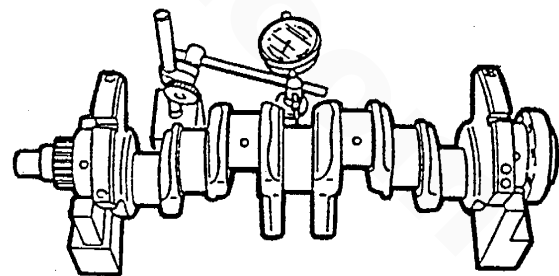

ENGINE INSPECTION AND REPAIR

Standard journal diameters:

- (1) Main journal diameter:
59.94 – 59.96 mm (2.360 – 2.361 in)
- (2) Crankshaft pin diameter:
50.94 – 50.96 mm (2.006 – 2.007 in)
- (3) Rear housing oil seal sliding surface:
89.95 – 90.00 mm (3.541 – 3.543 in)

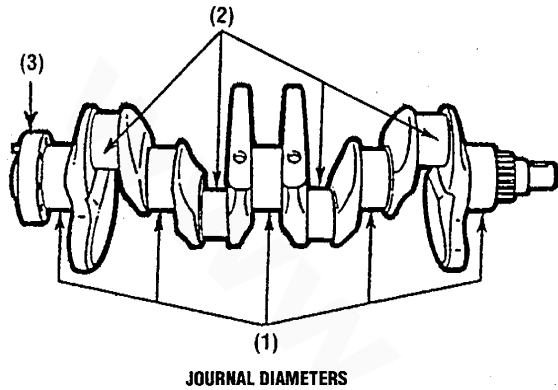

Journal wear limit: 0.05 mm (0.0020 in)

If the wear exceeds the limit, replace or grind the crankshaft to agree with the undersize bearing.

Journal grinding limit: 0.75 mm (0.0295 in)

Undersize bearings: 0.25 mm (0.010 in),
0.50 mm (0.020 in), 0.75 mm (0.0295 in)

CAUTION: When grinding the journal or pin, pay attention to each Fillet R dimension.
Fillet R dimension:
 2.6 – 3.0 mm (0.102 – 0.118 in)

Main Bearings and Connecting Rod Bearings.

1. Check the main bearings and connecting rod bearings.
2. Check the bearing inside surfaces for streaking, flaking, pin holes, etc.; replace all bearings as a set if there is a problem.

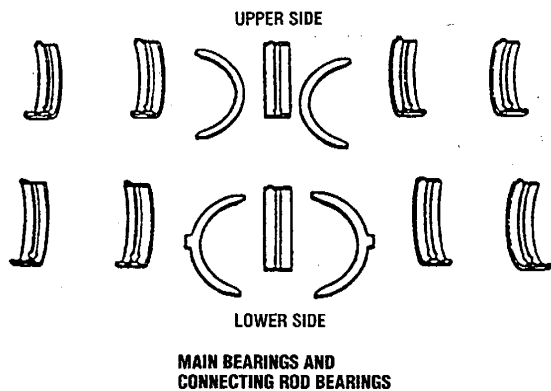

Timing belt

Replace the timing belt if it is contaminated with oil, grease or water, or if any of the following conditions exist:

1. Premature severance.
 - a. Check for proper installation.
 - b. Check the timing belt cover gaskets for damage and installation.

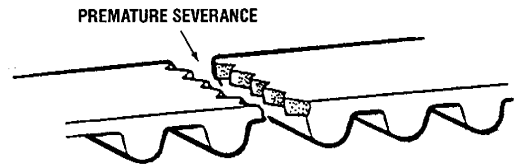

2. Check the teeth for damage, cracks, peeling and hardening, and check for any missing teeth.

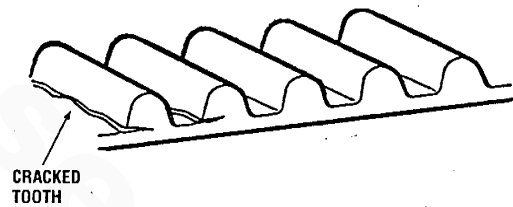
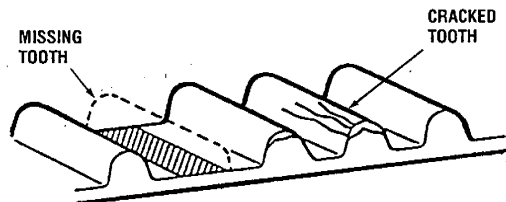

3. Check for noticeable wear or cracks on the belt face.

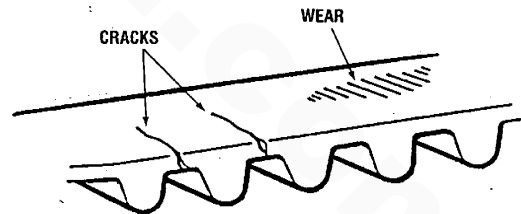

4. Check for wear or damage on only one side of the belt.

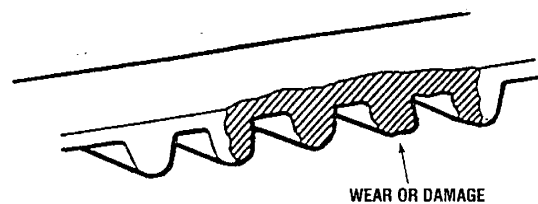

ENGINE INSPECTION AND REPAIR

5. Check for noticeable wear on the belt teeth.

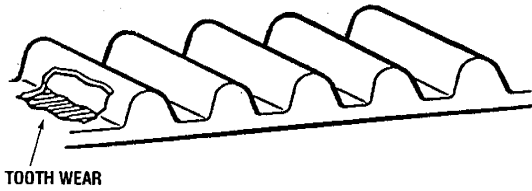

CAUTION: Never forcefully twist the timing belt, turn it inside out or bend it. Be careful not to allow oil, grease, or moisture on the belt.

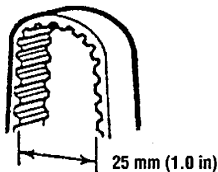

Timing Belt Tensioner

1. Check the rotation of the timing belt tensioner pulley, and check for play or abnormal noise. Replace if necessary.

CAUTION: Do not clean the tensioner with cleaning solvents. If it is dirty, use a clean rag to wipe it clean. Avoid scratching the surface the belt travels over.

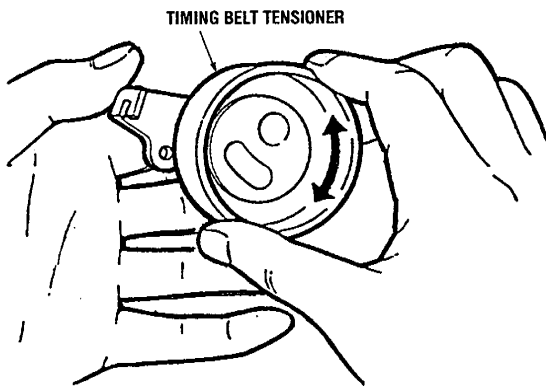

Timing Belt, Camshaft and Injection Pump Pulleys

1. Inspect the teeth on each pulley for wear, deformation or other damage. Replace if necessary.

CAUTION: Do not clean the pulleys. If they are dirty, use a clean rag to wipe them clean.

Timing Belt Covers (left, right)

1. Inspect each timing belt cover for deformation or cracks. Replace if necessary.
2. Inspect the gasket for deformation, cracks, or hardening. Replace if necessary.

ENGINE REASSEMBLY

GENERAL REASSEMBLY PROCEDURE

- Clean or wash the parts to be reassembled. Apply lubricating oil when specified or as needed to the surfaces of moving parts during reassembly. Heavily oil sliding, turning, rotating and reciprocating parts; lightly oil head bolts and other fasteners except those that penetrate into the water jacket. Make sure that moving parts, after assembly onto the engine, are not subject to binding or excessive tension.
- Carefully check gaskets, packings and oil seals, even if checking is not specified. Use new gaskets, lockwashers and O-rings.
- Be careful not to mix bolts and nuts. Both metric and S.A.E. bolts are used on various engine assemblies.
- Replace plain bearings if they are peeling, burned or otherwise damaged.
- Reassemble parts (e.g. pistons, piston rings, bearings, bearing caps) in their proper order, positions and directions relative to the engine block. Note that the cylinder head gasket, head bolt washers and thermostat are asymmetrical. Any mating marks that were drawn or scribed during disassembly should be positioned correctly for reassembly. Position gaskets carefully, especially the head gasket, so they will not be damaged during assembly.
- Inspect all critical clearances, end plays, oil clearances, and bends.
- Use liquid sealants when specified or needed on nuts, bolts and gaskets. Use *Permatex No. 2* or equivalent. Don't use tape sealants.
- Tighten the bolts and nuts on the important parts of the engine to the specified torques using a reliable torque wrench. Tighten fasteners in the specified torque sequences, and in three steps: 1/2, 2/3, and 1/1 torque; an exception is torque-to-yield head bolts. Where a tightening torque is not specified, tighten evenly to an ordinary torque.
- After completion of reassembly, recheck for any abnormalities. Prepare for starting the engine, and idle the engine sufficiently for a test run.

ENGINE REASSEMBLY

Valve Seals

NOTE: Always replace the valve seals during an engine overhaul.

1. Apply a coat of engine oil to the valve guides and the inside surfaces of the valve seals.
2. Using the **valve seal pusher** (49 S120 160), install the valve seals.

CAUTION: Be sure to use the special tool for the installation of the valve seals. If they are not installed correctly, oil might leak down into the cylinders during operation.

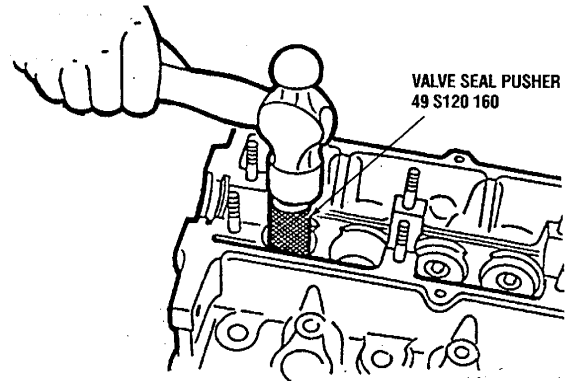

Valves

Install the valves onto the cylinder head as follows:

1. Install the lower spring seat.
2. Insert the valve after applying molybdenum disulphide grease to the valve stem.
3. Install the valve spring and upper spring seat.
4. Press the valve spring using the **valve spring lifter** (49 0636 100A) and **pivot** (49 S120 222). Then install the spring retainer securely.

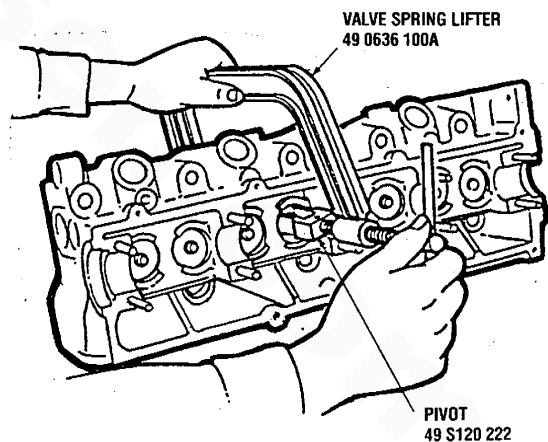

5. Move the No. 1 piston to top dead center, and then rotate the crankshaft approximately 45°.

CAUTION: If this is not done, the valves may be damaged by the pistons when tightening the camshaft cap nuts.

ENGINE REASSEMBLY

Tappets and Adjusting Discs

1. Apply engine oil to the tappets, then install the tappets to the tappet holes.
2. Install the adjusting discs.

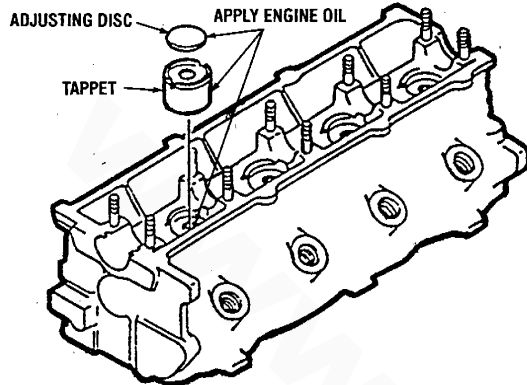

Pistons and Connecting Rods

1. Assemble the piston and connecting rod.
 - a. Align the oil hole in the large end of the connecting rod with the "F" mark on the piston.
 - b. Apply a coat of engine oil to the small end of the connecting rod and all over the piston.
 - c. Insert a snap ring into one of the piston pin holes in the piston.
 - d. Connect the piston and connecting rod by the piston pin, then lock the snap ring so it won't come out. (When doing this, the piston should be heated to 50 – 75°C.)

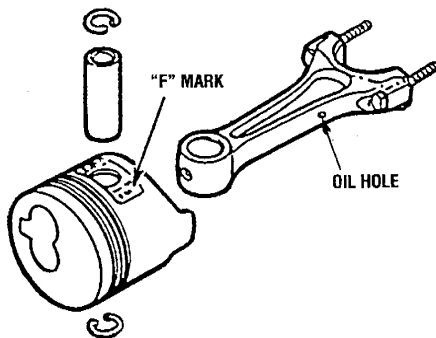

2. Assembly of the piston rings.
 - a. Assemble each piston ring to the piston by using a piston ring inserting tool (commercially available.). The order of assembly is: oil ring expander, oil ring, second ring, top ring.
 - b. Align the piston ring end gaps as shown in the illustration.

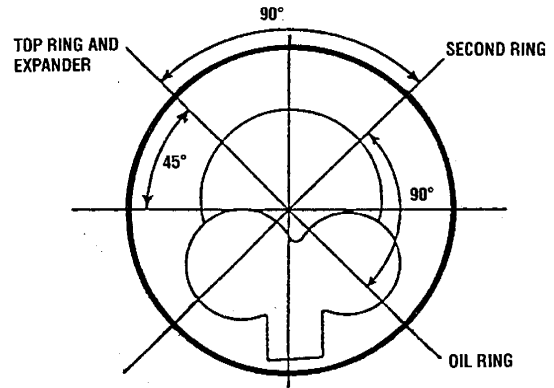

CAUTION: Apply a liberal coat of engine oil during installation. The rings must be mounted so the "R" or "RN" marks face upward.

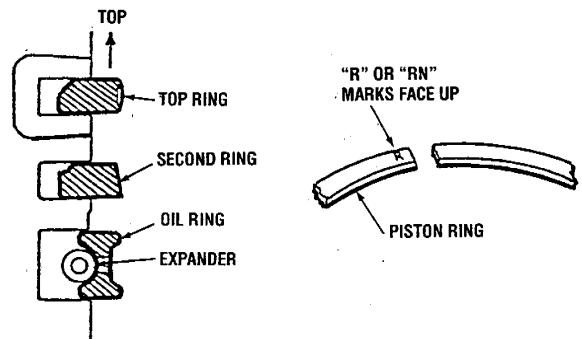

3. Install the piston and connecting rod.
 - a. Fit the connecting rod bearing to the connecting rod, then apply a coating of engine oil.
 - b. After cleaning the inner surface of the cylinder, apply a coating of engine oil.
 - c. Insert each piston and connecting rod into the cylinder block using a piston insertion tool (commercially available).

CAUTION: The pistons must be inserted so that the "F" marks face the front of the cylinder block. Apply a liberal coating of engine oil to the cylinder walls, piston circumference, and rings.

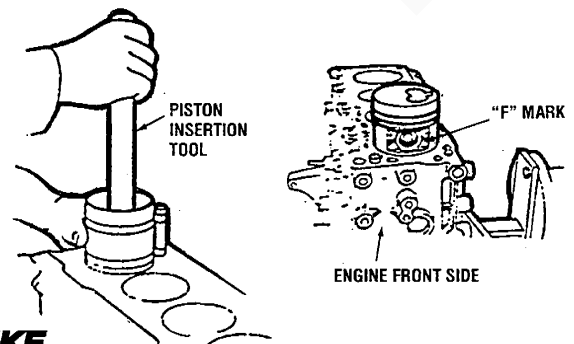

ENGINE REASSEMBLY

Crankshaft Assembly

1. Install the oil jets to the cylinder block.

Oil jet tightening torque:

1.2 – 1.8 kg-m (9 – 13 ft-lb)

2. Install the main bearings.

CAUTION: No oil, dirt, etc. should be on the back surface of the bearings.

The center main bearings cannot be interchanged with the other main bearings because their widths are different.

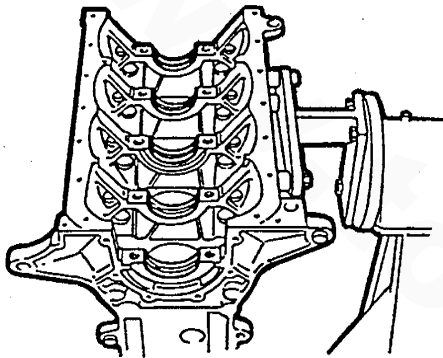

MAIN BEARINGS INSTALLATION

3. Check the oil clearance of the crankshaft and main bearings with a plastigauge.

- a. Remove any foreign material from the journal or bearing.
- b. Position the plastigauge on top of the journal (in the journal axial direction).
- c. Set the main bearing caps in position, then tighten them to the specified torque, in the sequence shown in the illustration.

Main bearing cap bolt tightening torque:

8.4 – 9.0 kg-m (61 – 65 ft-lb)

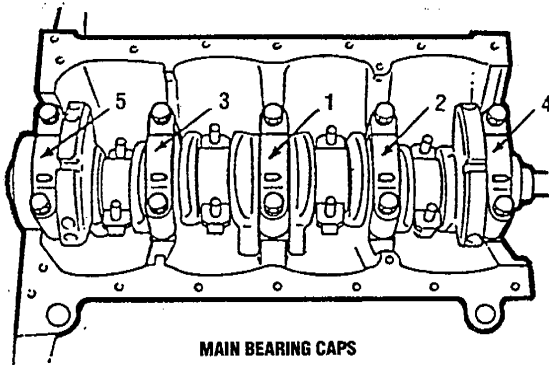

MAIN BEARING CAPS

- d. Remove the main bearing cap and measure the oil clearance.

Standard oil clearance:

0.031 – 0.049 mm (0.0012 – 0.0019 in)

Oil clearance limit: 0.08 mm (0.0031 in)

- e. If the oil clearance exceeds the limit, replace the main bearings with new ones, and measure the oil clearance again.
- f. In case the oil clearance exceeds the limit even when the main bearings are replaced, repair the crankshaft by grinding, and use undersize bearings.

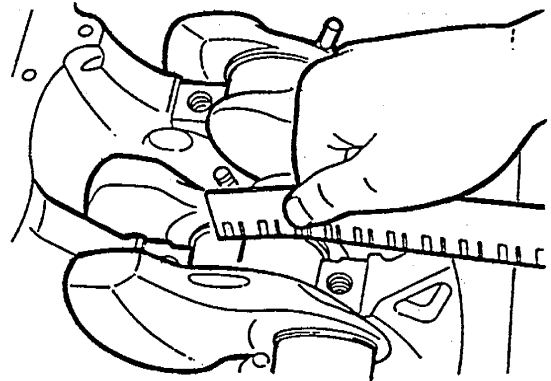

MEASURING CRANKSHAFT AND MAIN BEARINGS OIL CLEARANCE

CAUTION: Position the plastigauge horizontally on the crankshaft, away from the oil hole.

Do not rotate the crankshaft when measuring the oil clearance.

Install the main bearing cap according to the cylinder, number and the  mark.

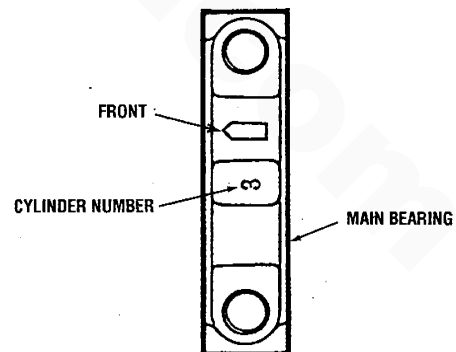

ENGINE REASSEMBLY

- After checking and correcting the oil clearance, apply a coating of engine oil to the main bearing and main journal, and then install the crankshaft.
- Apply a coat of engine oil to the thrust bearing, and install it to the center part of the main journal.

CAUTION: Install the thrust bearing so that the inner surface of the oil groove faces toward the cylinder block side.

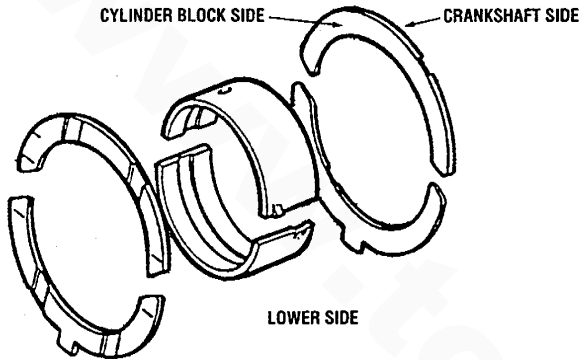

- If the end play is not within the standard range, select another thrust bearing.

Undersize thrust bearing width:
2.18 – 2.23 mm (0.0858 – 0.0878 in)

Standard thrust bearing width:
2.00 – 2.05 mm (0.0787 – 0.0807 in)

CAUTION: First replace the rear thrust bearings; if the end play is still not within the limit, replace the front thrust bearings also.

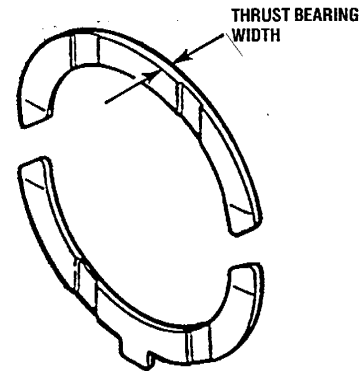

- With the main bearing cap in the set condition, manually push the crankshaft toward the front, then, with it pulled toward the rear, tighten the bolt to the specified torque.

Main bearing cap bolt tightening torque:
8.4 – 9.0 kg-m (61 – 65 ft-lb)

- Measure the end play of the crankshaft, and confirm that it is within the standard range. At this time, check to be sure that the crankshaft can be lightly turned.

Standard crankshaft end play:
0.04 – 0.28 mm (0.0016 – 0.0111 in)

End play limit: 0.3 mm (0.0118 in)

- Use a suitable piece of pipe to tap the pilot bearing onto the crankshaft.

CAUTION: Apply a coating of engine oil to the outer circumference of the pilot bearing and the crankshaft. Set a piece of pipe against the outer race of the bearing, and tap evenly. After installation, apply grease to the bearing.

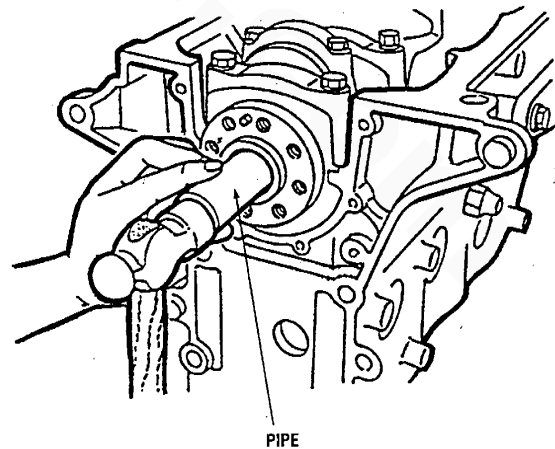
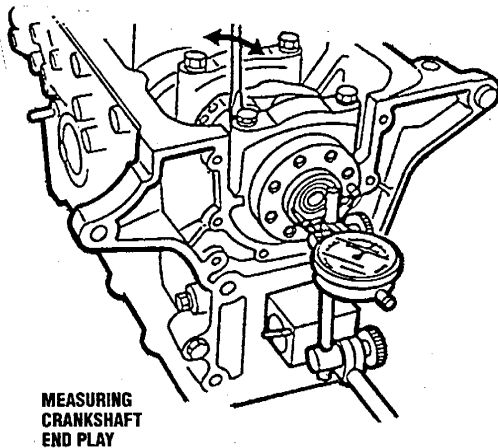

ENGINE REASSEMBLY

10. Install each connecting rod bearing cap as follows:

- a. Measure and adjust the connecting rod bearing and crankshaft pin journal oil clearance by the same procedure used to measure and adjust the crankshaft and main bearing oil clearance.

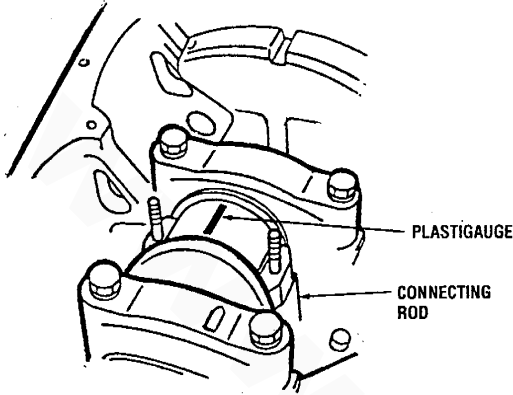

Standard oil clearance:

0.03 – 0.06 mm (0.0012 – 0.0024 in)

Oil clearance limit: 0.08 mm (0.0031 in)

Undersize connecting rod bearings:

0.25 mm (0.010 in), 0.50 mm (0.020 in),
0.75 mm (0.030 in)

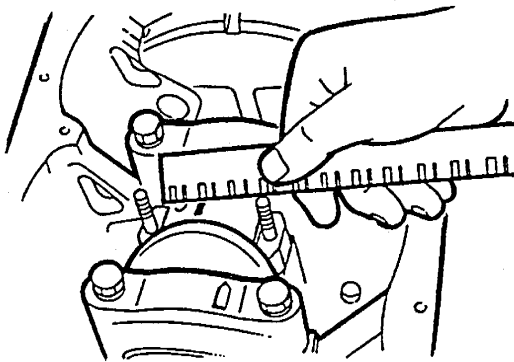

MEASURING CONNECTING ROD BEARING AND CRANKSHAFT PIN JOURNAL OIL CLEARANCE

- b. Check the end play of the connecting rod.

Standard connecting rod end play:

0.11 – 0.26 mm (0.0043 – 0.0102 in)

End play limit: 0.35 mm (0.014 in)

CAUTION: Measure the connecting rod end play before installing the connecting rod cap.

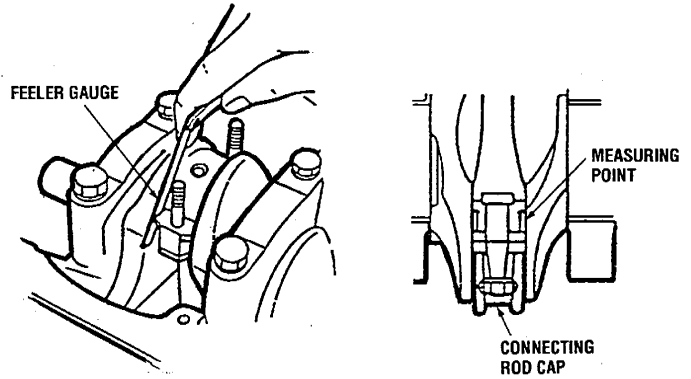

- c. Install the connecting rod bearing cap, and tighten to the specified torque. Before installing, apply a coating of engine oil to the bolt threads, nuts and bearing surfaces.

Connecting rod bearing cap tightening torque:
7.0 – 7.5 kg-m (51 – 54 ft-lb)

CAUTION: When installing the connecting rod cap, first align the cap and connecting rod matching marks.

Before installation, be absolutely sure to apply a coating of engine oil to the bearing.

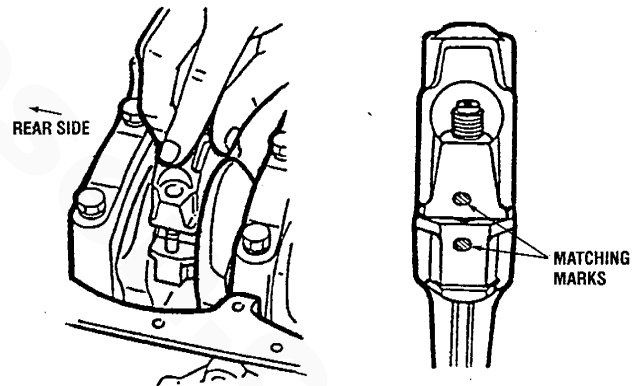

INSTALLING CONNECTING ROD BEARING CAP

Rear Cover Assembly

1. Apply engine oil to the rear cover and the oil seal.

CAUTION: Remember that when engine oil is applied to the cover and seal, it must also be applied to the oil seal lip.

ENGINE REASSEMBLY

2. Press the oil seal into the rear cover.

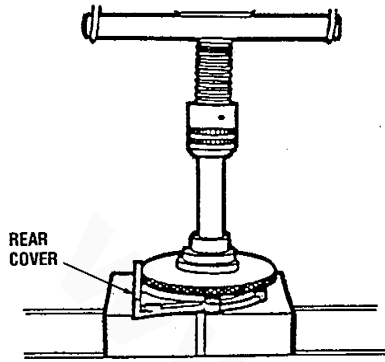

3. Install the rear cover assembly over the gasket.

Rear cover assembly tightening torque:
0.7 – 1.0 kg-m (5 – 7 ft-lb)

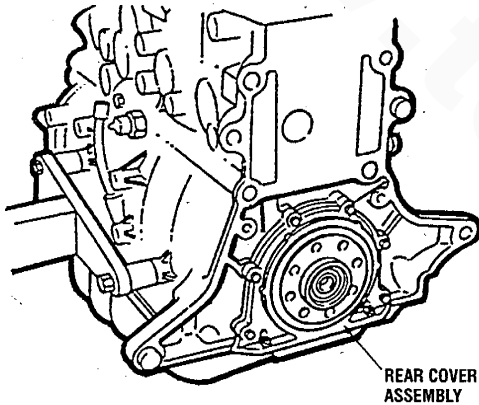

3. Install the oil pump assembly.

Oil pump assembly tightening torque:

M8 (smaller) bolts:
1.6 – 2.3 kg-m (12 – 17 ft-lb)

M10 (bigger bolts):
3.2 – 4.7 kg-m (23 – 34 ft-lb)

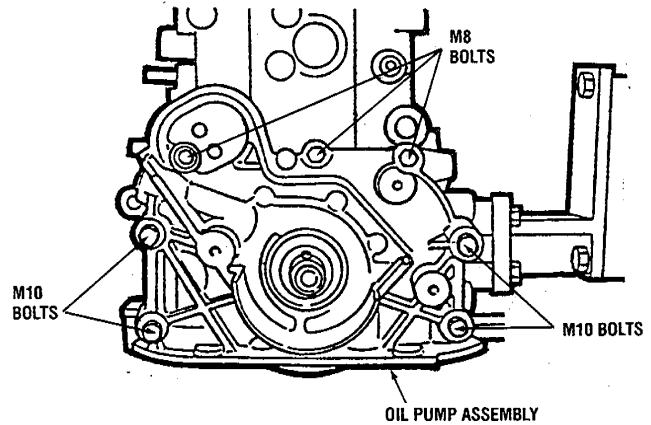

CAUTION: Do not let sealant get into the oil hole.

Apply engine oil to the oil seal lip.

Before applying the sealant, use a rag to thoroughly clean away any dirt or grease from the contact surfaces of the cylinder block and oil pump assembly.

Apply the sealant continuously without any interruption around the bead as shown in the illustration.

After installation, clean away any sealant which oozes out.

Oil Pump Assembly

NOTE: If it is necessary to service the oil pump, see OIL PUMP under LUBRICATION SYSTEM.

1. Install an O-ring applied with grease (lithium base, NLGI No. 2) onto the oil pump assembly.
2. Apply sealant (1016 77 739) to the surface shown by the shading in the illustration.

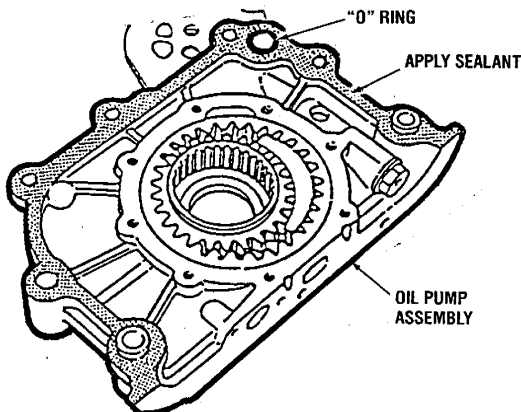

Oil Strainer and Oil Pan

NOTE: See OIL PAN under LUBRICATION SYSTEM for additional information.

1. Install the oil strainer on the oil pump body and cylinder block, then tighten it to the specified torque.

Oil strainer tightening torque:
0.7 – 1.0 kg-m (5 – 7 ft-lb)

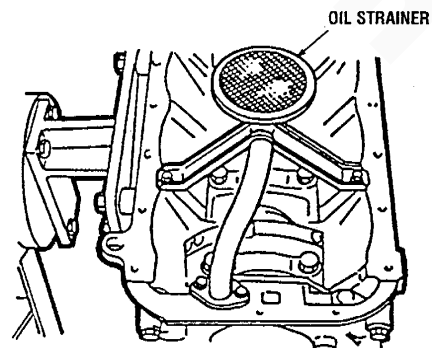

ENGINE REASSEMBLY

2. Cut away that part of the gasket which projects out from the rear cover assembly to the oil pan.

CAUTION: Do not scratch the rear cover assembly.

3. Follow this procedure to install the oil pan:
 - a. Apply sealant where the oil pan and cylinder block meet. Put it on continuously (thickness 2 – 4 mm, 0.08 – 0.16 in), rimming the surface inside the bolt holes; the end should overlap.

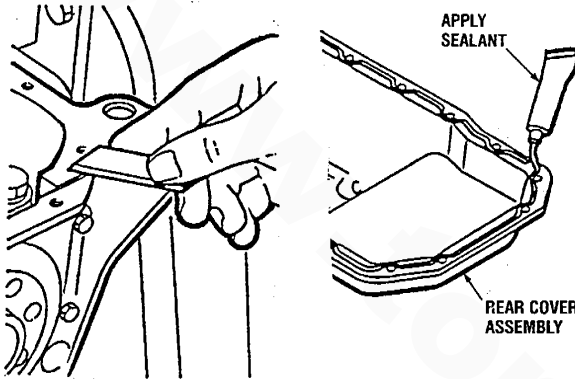

CAUTION: Before application, remove any dirt or grease from the contact surfaces with a rag. Apply sealant only to the cylinder block or the oil pan, not to both. After the sealant is applied, the pan must be secured within 30 minutes.

- b. If a gasket is used, apply sealant to the areas shown by the shading in the illustration. Then install the gasket and the oil pan, tightening to the specified torque.

Oil pan tightening torque:
0.7 – 1.0 kg-m (5 – 7 ft-lb)

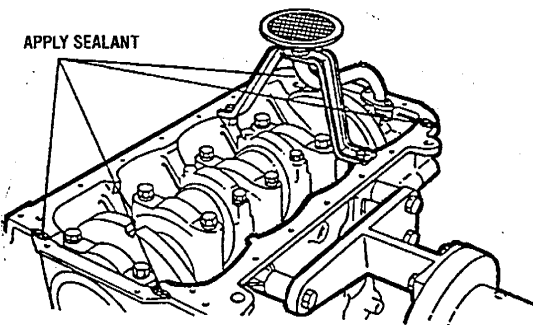

Back Plate and Flywheel

1. Install the back plate.

Back plate tightening torque:
1.6 – 2.3 kg-m (12 – 17 ft-lb).

2. Install the flywheel assembly, using the ring gear brake (49 V101 060).

Flywheel tightening torque:
18 – 19 kg-m (130 – 137 ft-lb).

CAUTION: Sealant (Part No. 8530 77 743) must be applied to the lock bolt threads to prevent oil leakage from the lock bolts. After installation, do not remove the ring gear brake.

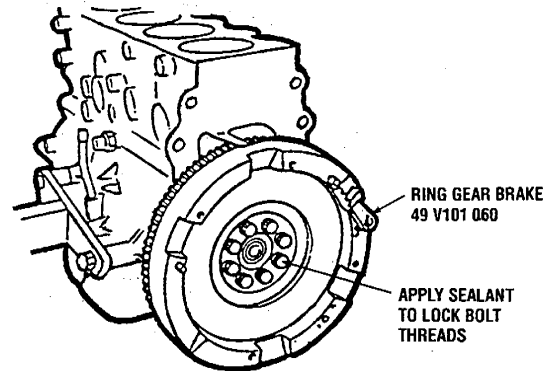

3. Install the damper plate onto the flywheel.

Damper plate tightening torque:
2.2 – 3.3 kg-m (16-24 ft-lb)

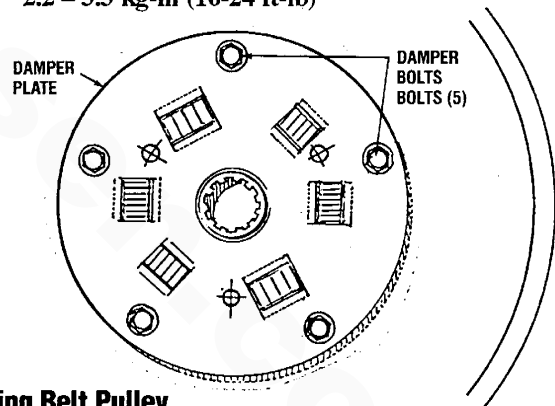

Timing Belt Pulley

1. Install the timing belt pulley with the semicircular (Woodruff) key and tighten it to the specified torque.

Timing belt pulley bolt tightening torque:
16 – 17 (kg-m (116 – 123 ft-lb)

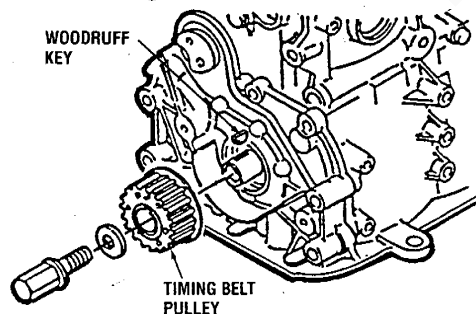

ENGINE REASSEMBLY

- Release the ring gear brake, turn the flywheel, move the No. 1 piston to the top position, and then turn the crankshaft clockwise approximately 45°.

CAUTION: This is to prevent damage to the piston and valve when the cylinder head is installed.

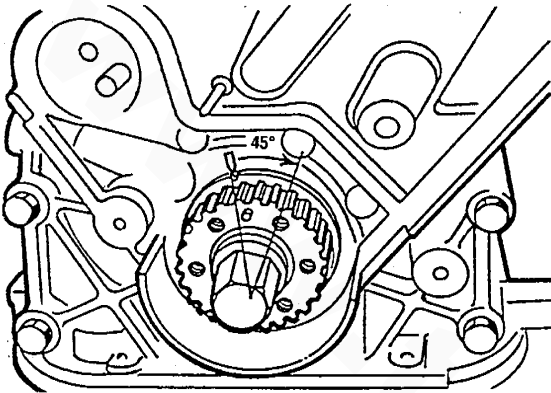

Cylinder head

- Thoroughly remove all dirt and grease from the top of the cylinder block with a rag.
- Place the cylinder head gasket in position.

CAUTION: Use a new cylinder head gasket.

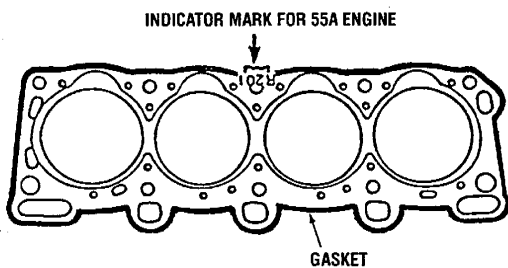

- Remove any dirt or grease from the bottom surface of the cylinder head.
- Place the cylinder head in position.
- Measure the length of the cylinder head bolt below the head. If the measured value is within the limit, apply a coating of engine oil to the threaded part and install.

Cylinder head bolt length:

Standard length:

112.7 – 113.3 mm (4.437 – 4.460 in)

Limit: 114.5 mm (4.508 in)

CAUTION: If the length of the bolt below the head exceeds the limit, the bolt must be replaced.

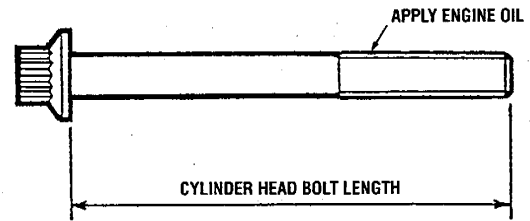

- Tighten the cylinder head bolts in the sequence shown in the illustration.

Cylinder head tightening torque:
3.0 kg-m (21.7 ft-lb)

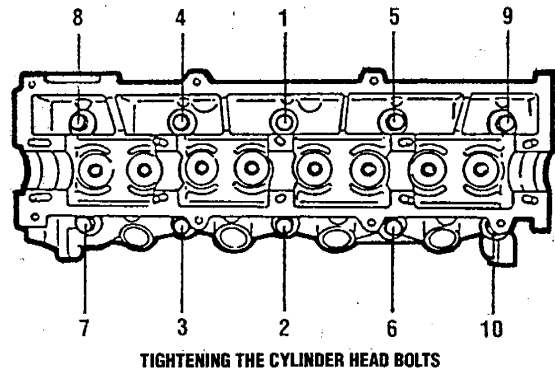

- Make paint marks on the bolt heads, as shown in the illustration below.
- With the paint marks as reference points, turn the cylinder head bolts *another* 90° (90° – 105°) in the tightening direction, turning them in the sequence shown in the illustration above.
- Then tighten them *once again* 90° more (90° – 105°) in the tightening sequence shown above.

CAUTION: Be absolutely sure to tighten all bolts in the sequence shown in the illustration.

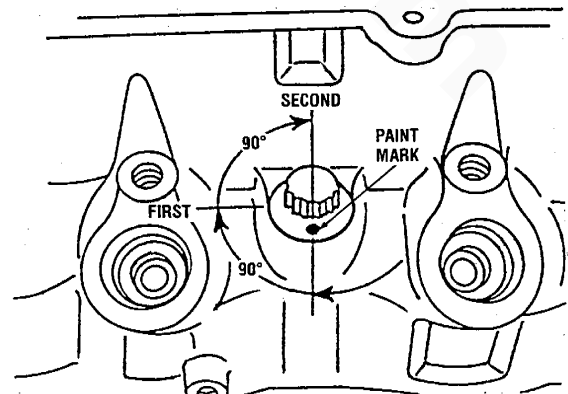

ENGINE REASSEMBLY

Camshaft

1. Apply a coat of engine oil to the camshaft and the cylinder head journals.
2. Insert the seal cap, and then apply sealant (1016 77 739) to the areas shown by the shading in the illustration.

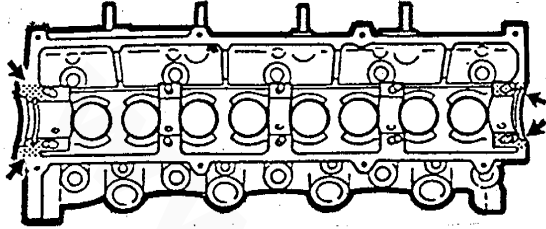

APPLYING SEALANT TO THE CYLINDER HEAD

3. Set the camshaft and camshaft cap in position, then loosely tighten the camshaft cap nuts.

NOTE: Set the camshaft so that the key groove faces directly upward.

4. Apply a coat of engine oil to the lip of the camshaft oil seal, and then insert the oil seal.

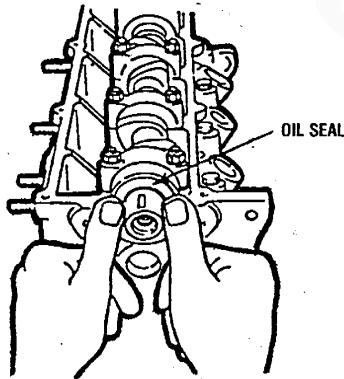

5. Tighten the camshaft cap nuts to the specified torque. See *Cylinder Head, 5.*, under *ENGINE INSPECTION AND REPAIR* for measurement of the oil clearance.

Camshaft cap nut tightening torque:
2.0 – 2.7 kg-m (15 – 20 ft-lb)

CAUTION: Tighten the camshaft cap nuts gradually and evenly, and in the sequence shown in the illustration.
The adjustment of the valve clearance should be made only after the camshaft pulley, injection pump pulley and timing belt have been installed.

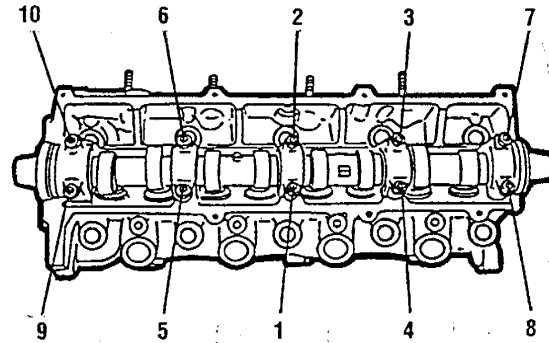

TIGHTENING THE CAMSHAFT CAP NUTS

Glow Plugs

NOTE: See *GLOW PLUGS* page for additional information.

1. Install the glow plugs and glow plug connectors. Use anti-seize compound on the threads.

Glow plug tightening torque:
1.5 – 2.0 kg-m (11 – 15 ft-lb)

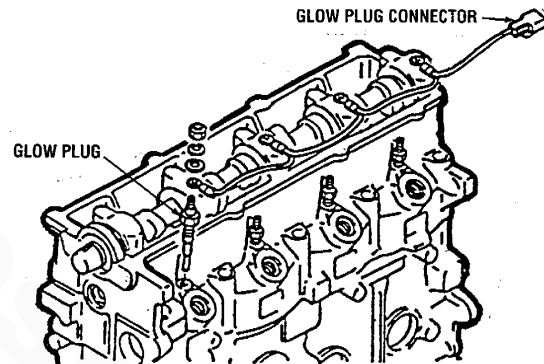

Injection Nozzles

NOTE: For testing information, see *TESTING FUEL INJECTORS* under *ENGINE ADJUSTMENTS*.

1. Install the heat shield washers, copper gaskets, injection nozzles and fuel return lines as shown in the illustration.

CAUTION: Be sure that the heat shield washer is positioned in the direction shown in the illustration. The heat shield washer and copper gasket must be replaced each time the injection nozzle is removed.

Injection nozzle tightening torque:
6.0 – 7.0 kg-m (43 – 51 ft-lb)

ENGINE REASSEMBLY

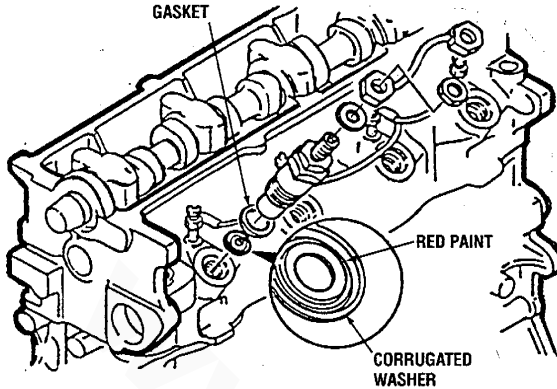

Oil Pressure Switch and Oil Dipstick Tube

1. Install the oil pressure switch.

Oil pressure switch tightening torque:
1.2 – 1.8 kg-m (9 – 13 ft-lb)

2. Install the oil dipstick tube.

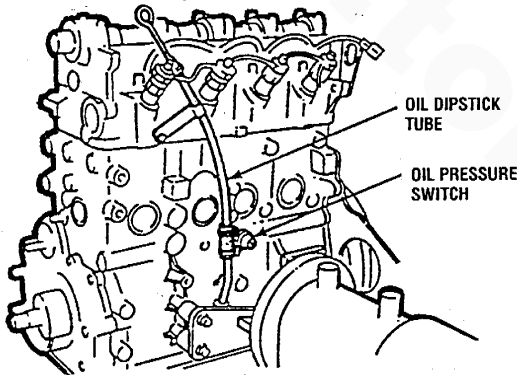

Injection Pump

1. Install the injection pump with the fuel feed line and the injection pump bracket.

NOTE: In case the fuel injection pump bracket and the fuel injection pump are separated, an injection timing adjustment will be necessary after installing the timing belt.

Injection pump tightening torque:
3.2 – 4.7 kg-m (23 – 34 ft-lb)

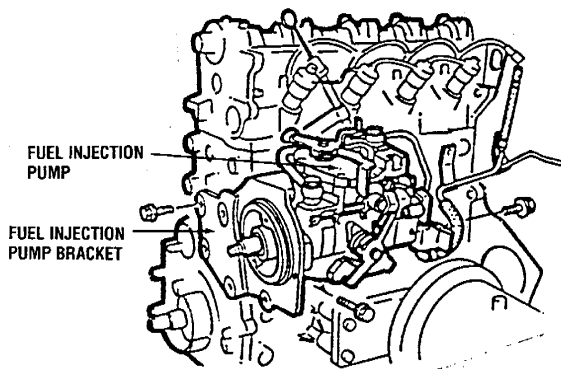

Fuel Injection Lines

1. Install the high pressure fuel injection lines from the injection pump to the injectors.

Fuel injection line tightening torque:
1.8 – 2.3 kg-m (13 – 17 ft-lb)

CAUTION: Check to be sure that no dirt or other foreign material has adhered to the fuel line coupling.

2. Tighten the clip channels.

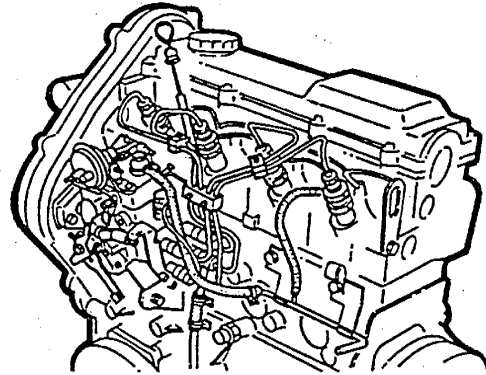

FUEL INJECTION LINES

Coolant Pump

NOTE: For additional information, see the COOLANT PUMP page.

1. Install the coolant pump with its gasket and tighten it to the specified torque.

Coolant pump tightening torque:
3.2 – 4.7 kg-m (23 – 34 ft-lb)

CAUTION: Before installation, remove any dirt from the contact surface. Use a new gasket.

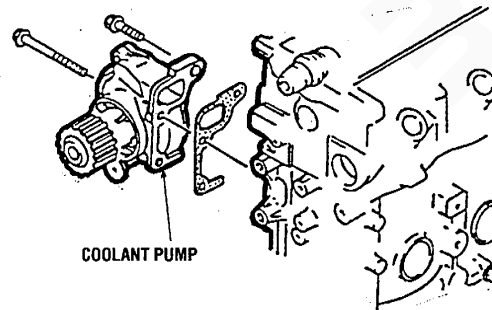

COOLANT PUMP

ENGINE REASSEMBLY

Seal Plate

1. Install the seal plate.

Seal plate tightening torque:

0.8 – 1.2 kg-m (6 – 9 ft-lb)

CAUTION: Be sure that the seal plate sealing rubbers are installed in position.

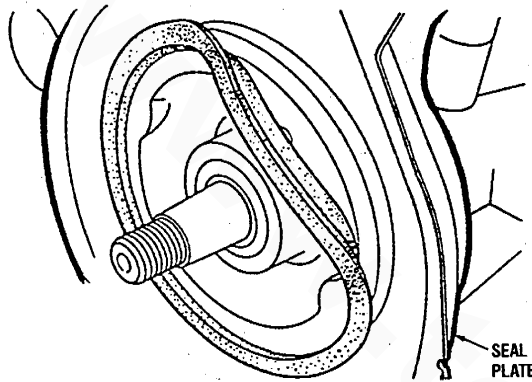

Idler Pulley Bracket

1. Install the idler pulley bracket.

Idler pulley bracket tightening torque:

3.2 – 4.7 kg-m (23 – 34 ft-lb)

NOTE: There are two different lengths of idler pulley bracket bolts.

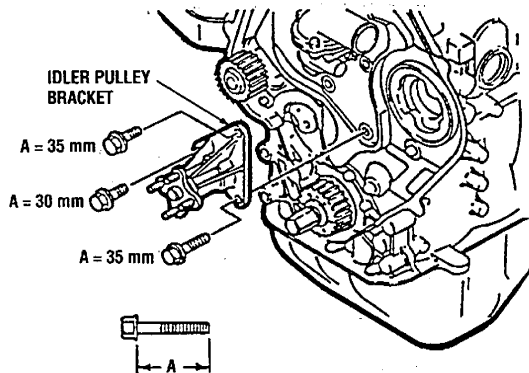

Thermostat Assembly

1. Install a new thermostat and a new gasket (the old thermostat can become a spare). Apply a thin coat of sealant to both sides of the gasket.
2. Inspect the thermostat housing, then install it.

Thermostat housing tightening torque:

1.6 – 2.3 kg-m (12 – 17 ft-lb).

3. Install the temperature switch and sender, and reconnect their wires.

4. Check the thermostat for proper operation by placing it in a pan of cold water and then raising the temperature of the water to a boil. The thermostat should open noticeably (with approximate travel between 1/4" – 1/2") and be fully opened when the water is boiling.

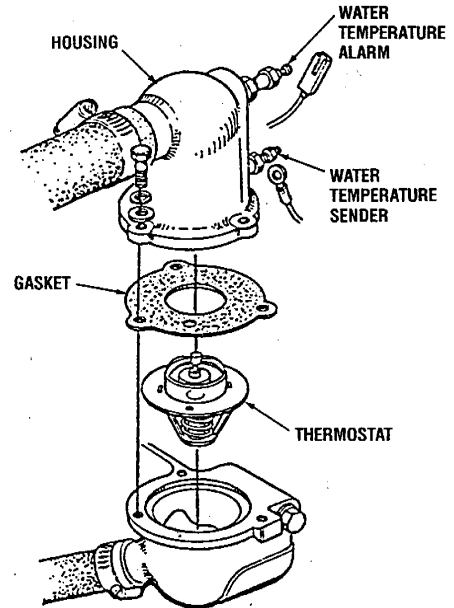

Camshaft Pulley

1. Install the camshaft pulley onto the camshaft with the semicircular (woodruff) key.
2. Hold the camshaft with a wrench (29 mm, 1.14 in), then tighten the camshaft pulley lock bolt to the specified torque.

Camshaft pulley bolt tightening torque:

5.6 – 6.6 kg-m (41 – 48 ft-lb)

CAUTION: Be sure that the mark on the camshaft pulley aligns with the mark on the seal plate. Don't damage the cylinder head edge with the wrench.

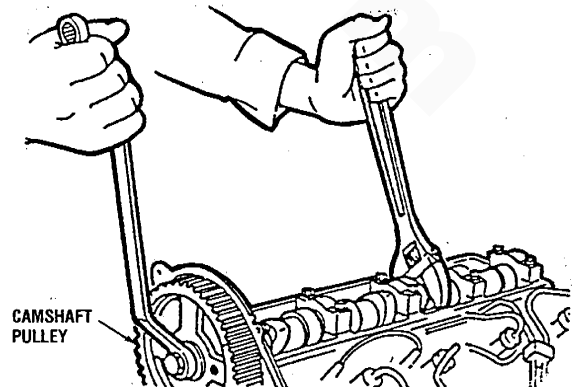

ENGINE REASSEMBLY

Injection Pump Pulley

1. Install the injection pump pulley with the semicircular (woodruff) key to the injection pump shaft.
2. Rotate the injection pump pulley until the timing mark on the injection pump pulley aligns with the timing mark on the seal plate.
3. Attach the injection pump pulley to the injection pump bracket using the two bolts (35 – 40 mm long), and tighten it to the specified torque.

Injection pump pulley tightening torque:
6.0 – 7.0 kg-m (43 – 52 ft-lb)

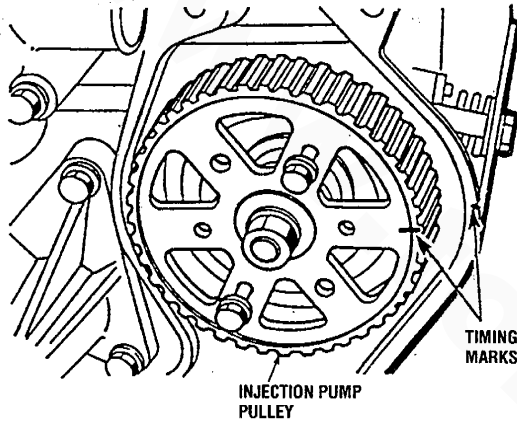

Timing Belt Tensioner

1. Check to ensure that the timing marks on the pulleys are aligned with the timing marks on the seal plate.

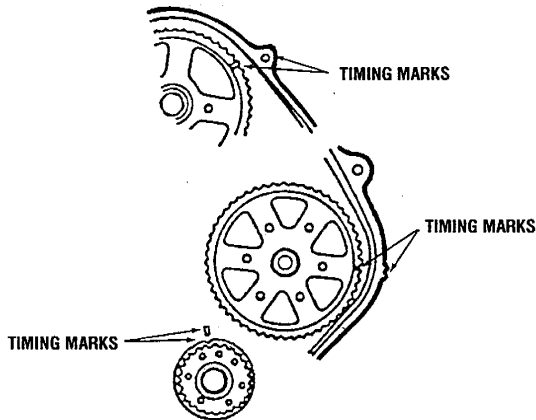

2. Install the timing belt tensioner, locking bolt and spring.
3. Push the timing belt tensioner to the left toward the water pump as far as it will go and then tighten the locking bolt to temporarily hold the tensioner in place.

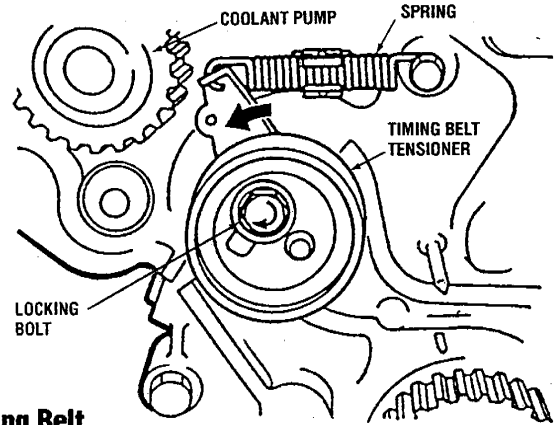

Timing Belt

1. Return the crankshaft approximately 45° to the timing mark which is marked on the oil pump housing.

CAUTION: Check to ensure that the timing marks on the camshaft pulley and the injection pump pulley are aligned with the timing marks on the seal plate.

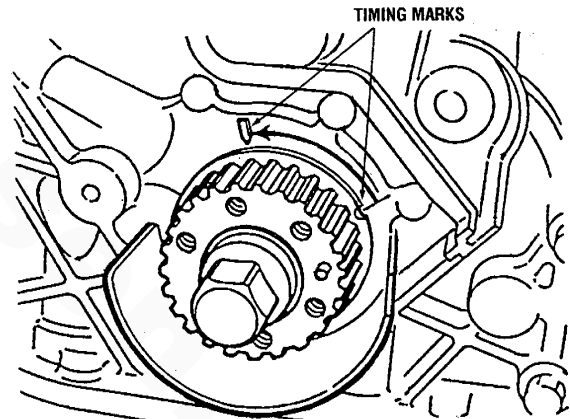

2. Install the timing belt.

CAUTION: If reinstalling the original belt, be sure the arrow that was drawn on the belt points in the direction of the engine's rotation.

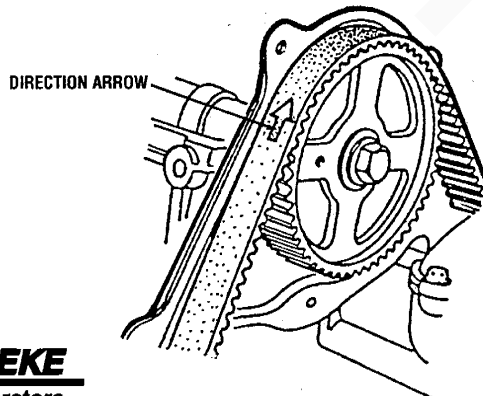

ENGINE REASSEMBLY

3. Remove the two attaching bolts from the injection pump pulley.
4. Loosen the tensioner lock bolt so that tension is applied to the timing belt by the tensioner spring.
5. Turn the crankshaft twice in the direction of normal engine rotation (clockwise) to equalize tension on the timing belt.

CAUTION: Do NOT rotate the crankshaft in the reverse of its normal rotation.

6. Tighten the timing belt tensioner lock bolt.

Timing belt tensioner lock bolt tightening torque:
3.2 – 4.7 kg-m (23 – 34 ft-lb)

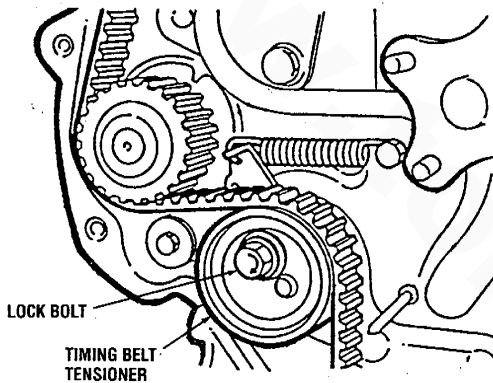

7. Recheck the timing mark positions on the crankshaft, camshaft pulley and injection pump pulley with the timing marks on the gear case.
8. Check the timing belt deflection at the position shown in the illustration.

Standard timing belt deflection (engine is cold):
10.8 – 12.9 mm (0.43 – 0.51 in)/10kg (22 lb)

CAUTION: If the deflection isn't within the specification, repeat the procedure from Step 1.

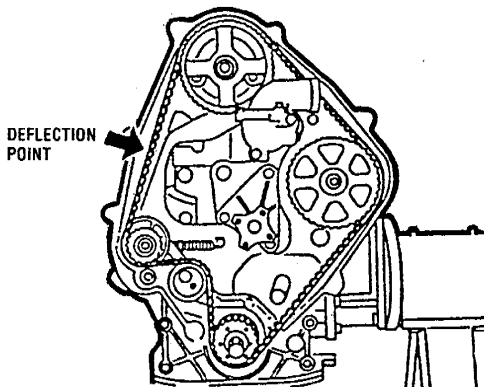

9. Install the left timing belt cover with its rubber seal.
10. Install the right timing belt cover with its rubber seal.

Timing belt cover bolts tightening torque:
0.7 – 1.0 kg-m (5 – 7 ft-lb)

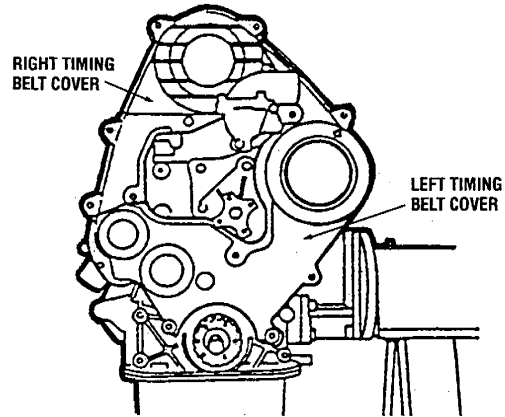

Crankshaft Pulley and Torsional Damper

1. Install the crankshaft pulley and the torsional damper onto the timing belt drive gear with the semicircular (woodruff) key. Tighten the attachment.

Crankshaft pulley bolt tightening torque:
2.3 – 3.3 kg-m (17 – 24 ft-lb)

NOTE: When installing the torsional damper onto the timing belt drive gear, align the mark on the damper with the knock pin on the gear.

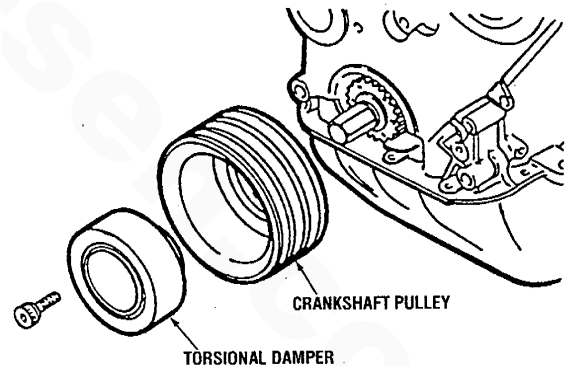

Intake/Exhaust Manifold Assembly

NOTE: For additional information, see the INTAKE/EXHAUST MANIFOLD page.

1. Remove the air intake manifold, clean the two air filters, then reassemble.
2. Place the intake/exhaust manifold gaskets in position.
3. Install the intake/exhaust manifold in its entirety, and tighten it to the specified torque.

Intake exhaust manifold tightening torque:
2.2 – 2.7 kg-m (16 – 20 ft-lb)

ENGINE REASSEMBLY

- Attach the exhaust elbow, the two exhaust manifold hoses, and the coolant recovery tank hose.

For additional servicing information, see the *INTAKE/EXHAUST MANIFOLD* page.

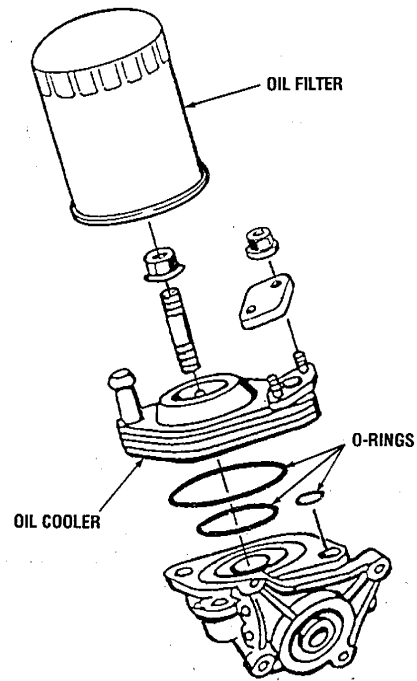
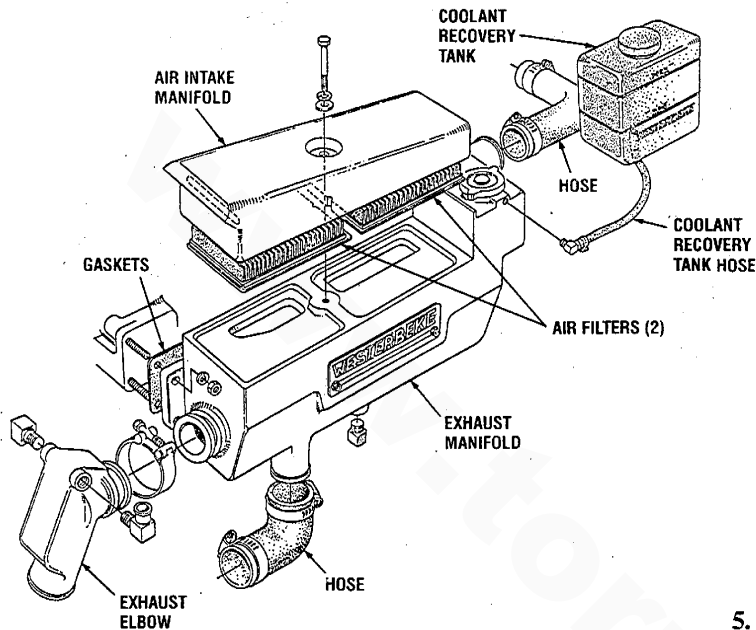

Oil Cooler/Oil Filter Assembly

NOTE: For additional information, see *OIL COOLER* under *LUBRICATION SYSTEM*.

- Install three new O-rings into the oil cooler and apply a coating of engine oil to them.
- Install the oil cooler assembly, and tighten it to the specified torque.

Oil cooler tightening torque:

M10 bolt (bigger): 3.2 – 4.7 kg-m (23 – 34 ft-lb)

M6 bolt (smaller): 0.7 – 1.0 kg-m (5 – 7 ft-lb)

- Before installing a new spin-on oil filter, wipe the filter gasket's sealing surface on the oil cooler free of oil, and apply a thin coat of clean engine oil to the rubber gasket on the new oil filter.
- Screw the oil filter onto the threaded stub, and tighten firmly by hand.

- Install the water hose with a new gasket.

Water hose tightening torque:

Bracket: 1.9 – 2.6 kg-m (14 – 19 ft-lb)

Flange: 0.8 – 1.1 kg-m (5.8 – 8.0 ft-lb)

Alternator

NOTE: For additional information, see *DC ELECTRICAL SYSTEM/ALTERNATOR*.

- Install the alternator bracket, and tighten it to the specified torque:

Alternator bracket tightening torque:

3.2 – 4.7 kg-m (23 – 34 ft-lb)

- Install the alternator and drive belt. Insure that the belt is in proper alignment with the crankshaft pulley and the idler pulley. Check the belt tension.

Alternator drive belt deflection:

New: 11 – 12 mm (0.44 – 0.47 in)/10 kg (22lb)

Used: 12 – 14 mm (0.47 – 0.55 in)/10kg (22lb)

ENGINE REASSEMBLY

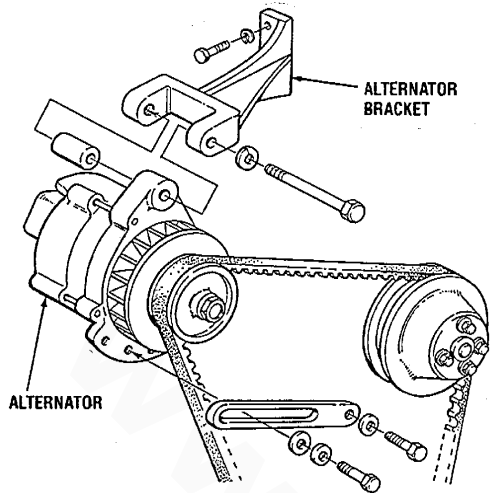

Valve Clearance Adjustment

1. Measure the valve clearance and adjust it (see *VALVE CLEARANCE ADJUSTMENT* under *ENGINE ADJUSTMENTS*).

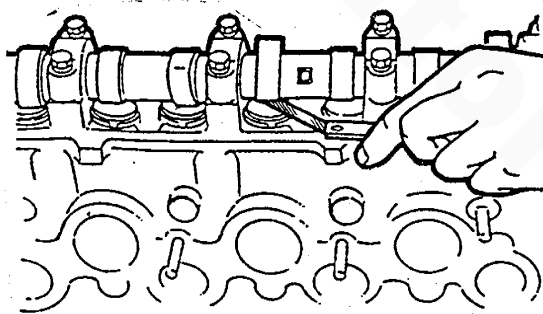

VALVE CLEARANCE ADJUSTMENT

Cylinder Head Cover

1. Apply sealant to the areas shown by the shading in the illustration.
2. Place the gasket in position.
3. Install the cylinder head cover, and tighten it to the specified torque.

Cylinder head cover tightening torque:
0.7 – 1.0 kg-m (5 – 7 ft-lb)

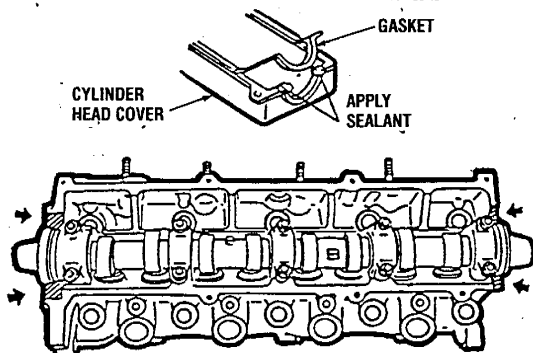

4. Install the PCV hose.
5. Remove the engine from the engine hanger (49 G030 005).

Engine Mounts

1. Install the engine mounts and tighten them to the specified torque.

Engine mount tightening torque:
3.2 – 4.7 kg-m (23 – 34 ft-lb)

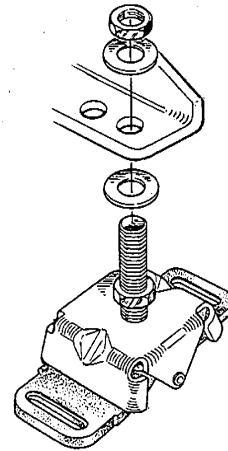

Fuel Filter

Mount the fuel filter assembly, then connect the fuel supply line to the filter.

Bellhousing/Heat Exchanger/Damper Plate

1. Install the bellhousing.
2. Mount the heat exchanger on the bellhousing.
3. Mount the transmission damper plate to the flywheel.

Cooling System

1. Install the raw water pump and its drive belt. Make sure the belt is in proper alignment with the crankshaft pulley. Check the belt tension.
2. Install new hose connections and clamps for the cooling system.

Electrical Equipment

1. Install the oil and water senders and switches.
2. Install the starter motor.
3. Install the breaker panel and the preheat solenoid.
4. Install the engine wiring harness.

CAUTION: Check all AC and DC wiring connections. Refer to Westerbeke's wiring schematics and diagrams.

ENGINE REASSEMBLY

Transmission

Reinstall the HBW marine transmission and fill with ATF Dextron III.

NOTE: Some transmissions such as the *Borg Warner Velvet Drive* require oil coolers. Oil coolers should be cleaned, pressure tested and repainted at engine overhaul.. The transmission oil cooler hoses should also be inspected (refer to *HEAT EXCHANGERS*).

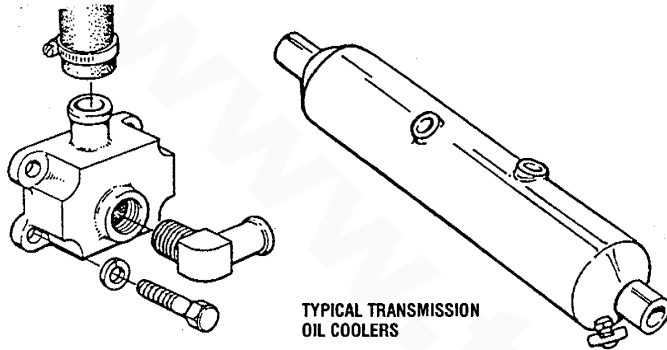

Idle Speed Adjustment

Check the idle speed adjustment after the engine has had a test run — see *IDLE SPEED ADJUSTMENT* under *ENGINE ADJUSTMENTS*.

Fluids

1. Fill the engine cooling system with antifreeze mixture.
2. Fill the engine oil sump with lube oil.

Lubrication system oil grade:
API Specification CF or CG-4,
SAE30, 10W-30, 15W-40.

Test Run

Test run the engine under load prior to reinstalling. Check for oil leaks.

ENGINE ADJUSTMENTS

DRIVE BELT ADJUSTMENT

CAUTION: Drive belts must be properly tensioned. Loose drive belts will not provide proper alternator charging and will eventually damage the alternator. Drive belts that are too tight will pull the alternator out of alignment and/or cause the alternator to wear out prematurely.

To check the belt tension, apply moderate pressure (10 kg, 22 lb) midway between the pulleys. Check the deflection, and adjust it if necessary.

CAUTION: Replace the drive belt if it has become worn, cracked, or frayed.

Belt Deflection	
New Belt	Used Belt
11 – 12 mm (0.44 – 0.47 in)	12 – 14 mm (0.47 – 0.55 in)

Belt tension adjustment is made by pivoting the alternator on its base mounting bolt.

- Loosen the alternator adjusting strap bolt and the base mounting bolt.
- Pivot the alternator on the base mounting bolt to the left or right as required.
- Tighten the base mounting bolt and the adjusting strap bolt.
- Operate the engine for about 5 minutes at idle, then shut down and recheck the belt tension.

CAUTION: Use only genuine WESTERBEKE drive belts; poor quality belts will lead to premature wear and belt elongation resulting in alternator damage.

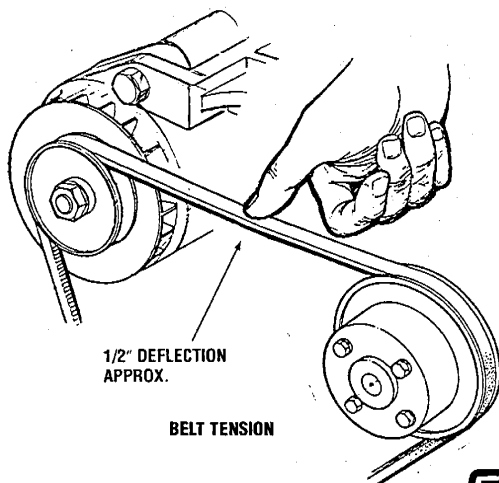

VALVE CLEARANCE ADJUSTMENT

- Remove the cylinder head cover.
- Manually rotate the engine crankshaft and bring the #1 piston up to the TDC of its compression stroke.

NOTE: When this occurs, the intake and exhaust cam lobes will face upwards.

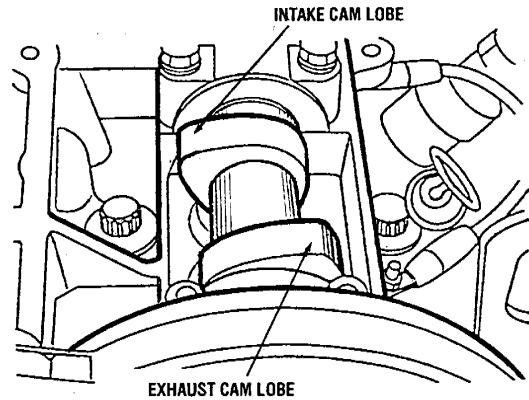

- Measure the valve clearance of the #1 cylinder by using a thickness gauge.

Standard valve clearances (engine is cold):

Intake: 0.20 – 0.30mm (0.008 – 0.012 in)

Exhaust: 0.30 – 0.40 mm (0.012 – 0.016 in)

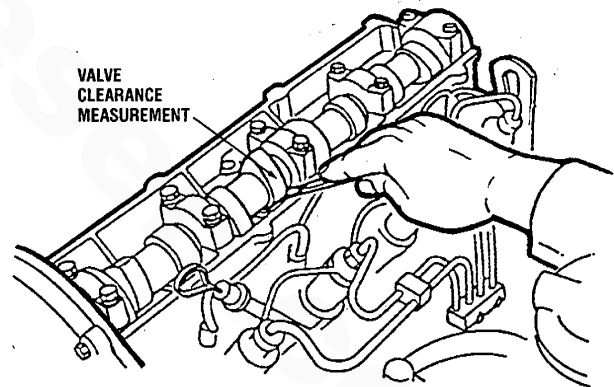

If the valves clearances are not within the standard values, use the following procedure to adjust the valves.

- Rotate the intake valve cam lobe so that it points straight up.
- Rotate the tappet so that one of the notches is facing the exhaust manifold. This allows for better access to the adjusting disc.
- Using the tappet holder WESTERBEKE #41978, press the tappet down to the position where the adjusting disc becomes accessible.



ENGINE ADJUSTMENTS

- Using a small screwdriver or magnet, remove the adjusting disc.
- Select an appropriate disc thickness for the valve clearance measured. Install the disc and verify the correct clearance.

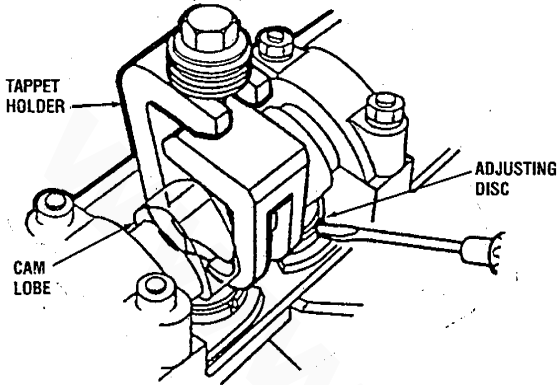

EXAMPLE (Intake Valve): The thickness of the disc removed plus the clearance measured minus the standard clearance will give the thickness of the new adjusting disc.

$$4.00 \text{ mm} + (0.30 - 0.25 \text{ mm}) = 4.05 \text{ mm}$$

$$0.157 \text{ in} + (0.012 - 0.010 \text{ in}) = 0.159 \text{ in.}$$

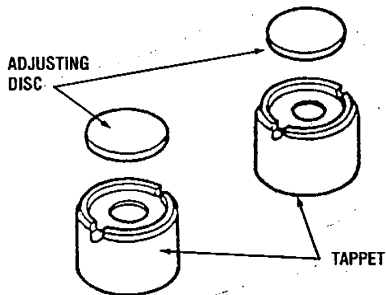

NOTE: The number marked on the disc indicates its thickness. Example: 3825 means 3.825 mm (0.1056 in). Adjusting discs are available in 25 different thicknesses between 3.40 and 4.60 mm (0.1339 - 0.1811 in) at variations of 0.050 mm (0.002 in).

- Measure and adjust, as needed, the valves in cylinders #3, #4 and #2 following the instructions above.

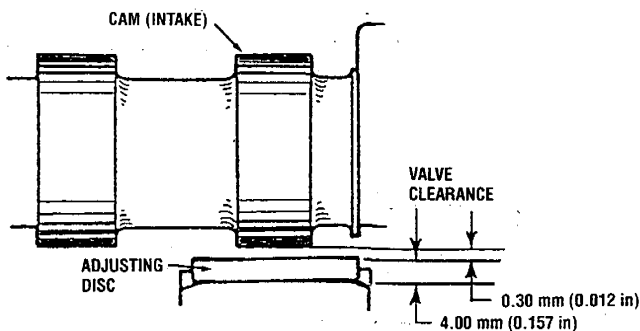

TIMING BELT

NOTE: WESTERBEKE recommends replacing the timing belt during an engine overhaul. Timing belt failure could result in major damage to the engine.

Removal

NOTE: In case the timing belt is to be reused, draw an arrow on the belt pointing in the direction of the belt's rotation, so it will be replaced in the same direction.

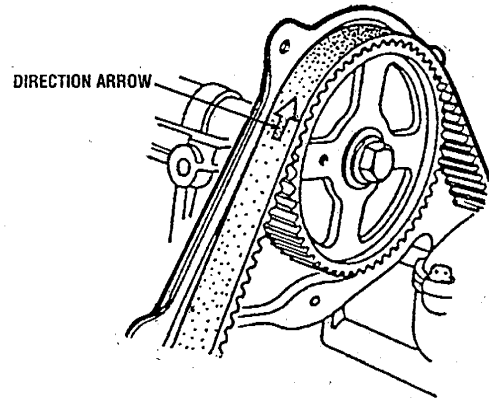

- Before removing the timing belt, rotate the engine crankshaft by hand in the direction of the engine's normal rotation (clockwise) and align the three pairs of timing marks as shown in the illustration.

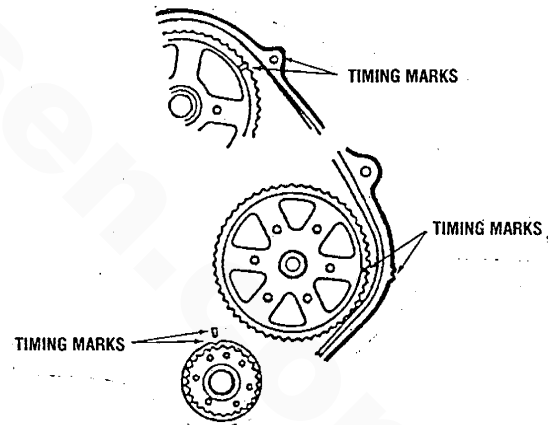

- Loosen the timing belt tensioner lock bolt, push the timing belt tensioner left as far as it will go, then temporarily retighten the lockbolt.

ENGINE ADJUSTMENTS

3. Remove the timing belt.

CAUTION: After removal of the timing belt, DO NOT rotate the crankshaft pulley or the camshaft pulley; if they are rotated, the pistons will damage the opened valves.

Inspection

Replace the timing belt if it is contaminated with oil, grease or water, or if any of the following conditions exist:

1. Premature severance.
 - a. Check for proper installation.
 - b. Check the timing belt cover gaskets for damage and installation.

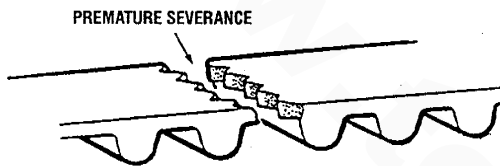

2. Check the teeth for damage, cracks, peeling and hardening, and check for any missing teeth.

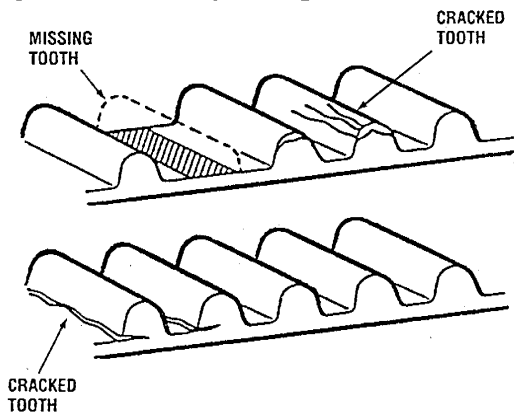

3. Check for noticeable wear or cracks on the belt face.

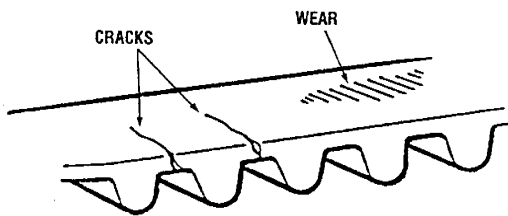

4. Check for wear or damage on only one side of the belt.

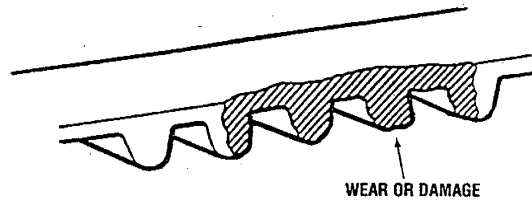

5. Check for noticeable wear on the belt teeth.

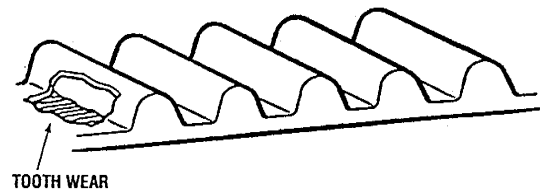

CAUTION: Never forcefully twist the timing belt, turn it inside out or bend it. Be careful not to allow oil, grease, or moisture on the belt.

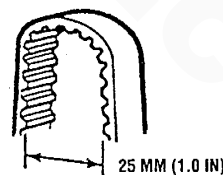

ENGINE ADJUSTMENTS

Installation

1. Check to ensure that the timing marks on the pulleys are aligned with the timing marks on the seal plate.
2. Install the timing belt.

NOTE: If reinstalling the original belt, be sure to install with the arrow in the correct direction of belt rotation.

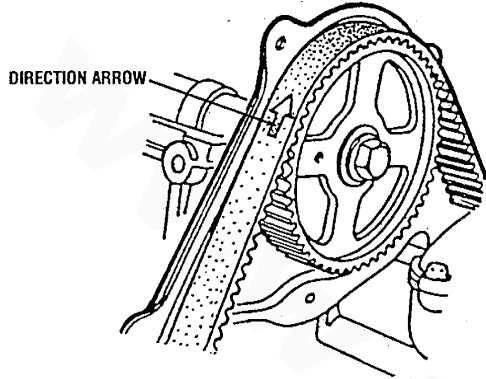

3. Loosen the timing belt tensioner lock bolt to allow the timing belt tensioner to bring pressure on the timing belt.

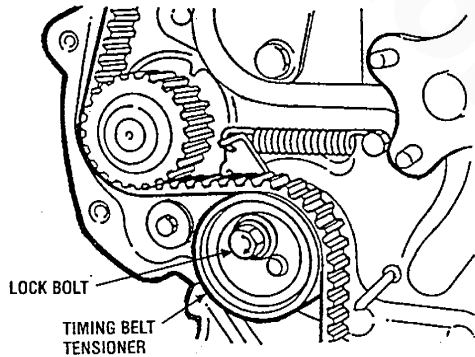

4. Turn the crankshaft twice in the direction of normal engine rotation (clockwise) to equalize tension on the timing belt.

NOTE: Do not turn the engine in the reverse of its normal rotation.

5. Tighten the timing belt tensioner lock bolt.

Lock bolt torque: 3.2 – 4.7 kg-m (23 – 34 ft-lb)

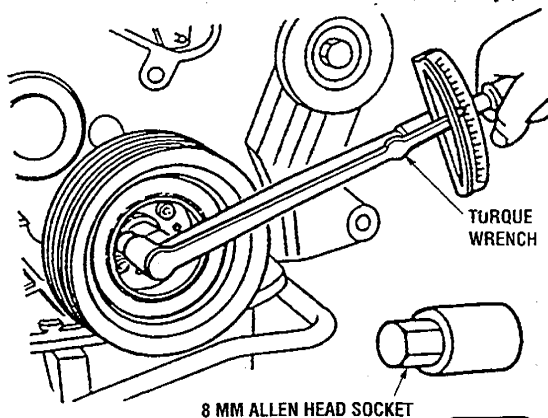

6. Recheck the timing mark positions between the three pulleys and the seal plate. Check the timing belt deflection with a pushing force of 10 kg (22 lb) at the point on the belt shown in the illustration.

Standard deflection (engine is cold):
10.8 – 12.9 mm (0.43 – 0.51 in)

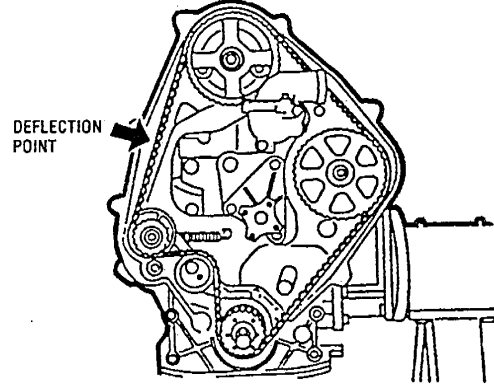

7. Install the left timing belt cover with its rubber seal.
8. Install the right timing belt cover with its rubber seal.

Bolt torque for the timing belt cover bolts:
0.7 – 1.0 kg-m (5 – 7 ft-lb)

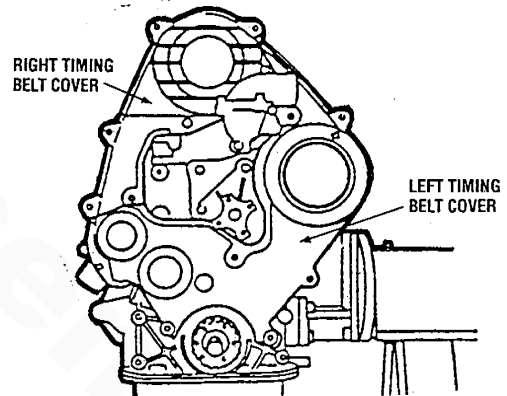

9. Install the crankshaft pulley and the torsional damper onto the timing belt drive gear with the semicircular (woodruff) key. Tighten the attachment.

Crankshaft pulley bolt torque:
2.3 – 3.3 kg-m (17 – 24 ft-lb)

NOTE: When installing the torsional damper onto the timing belt drive pulley, align the mark on the damper with the knock pin on the pulley.

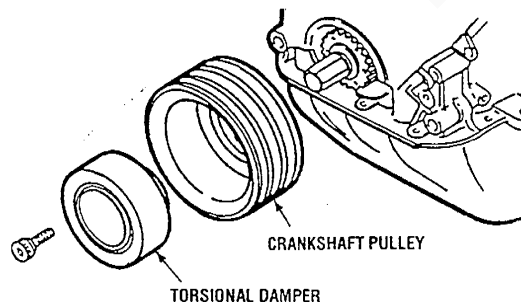

ENGINE ADJUSTMENTS

COMPRESSION TEST

NOTE: When performing the compression test, shut off the raw water supply to the engine-mounted raw water pump. This is to prevent raw water from filling the exhaust system while testing.

1. Warm the engine up to operating temperature.
2. Stop the engine.
3. Remove all four fuel injectors or all four glow plugs.
4. Disconnect the DC power connection to the fuel shutoff solenoid on the fuel injection pump.
5. Install the **compression gauge adapter** (49 1456 010) in the injector hole or glow plug opening of #1 cylinder. Connect the compression tester to the adapter.
6. Crank the engine with the starter and allow the gauge to reach its maximum reading.
7. Record the reading and proceed to the next cylinder. Repeat this process for each cylinder.
8. Compare the readings to the table below. Take corrective action as needed.

Compression pressure	kg/cm ² (lb/in ²)-rpm
Standard	30 (426) — 200
Limit	27 (384) — 200

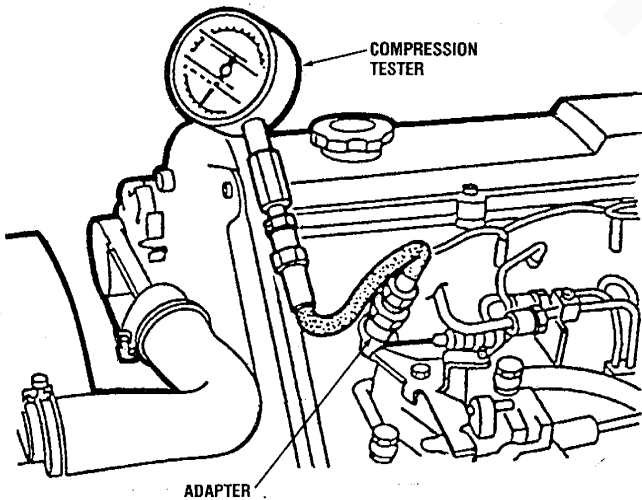

NOTE: Do not guess the conditions of other cylinders from a result of testing one cylinder. Be sure to measure the compression pressure for each cylinder. Look for cylinders with dramatically (at least 20%) lower compression than the average of the other cylinders. If the weak cylinder is flanked by healthy cylinders, the problem is either valve or head-gasket related. Very low compression in an adjacent cylinder indicates gasket failure. Abnormally high readings on all cylinders indicate heavy carbon accumulations, a condition that might be accompanied by high pressures and noise.

NOTE: In case of severe vibrations and detonation noise, have the injectors overhauled by an authorized fuel injection facility. Poor fuel quality, contaminates, and loss of positive fuel pressure to the injection pump will result in injector faults.

If the glow plugs were removed, use anti-seize compound when reinstalling them.

TESTING THE OIL PRESSURE

NOTE: Insure that the oil meets the following standards: API Specification CF or CG-4, SAE 30, 10W-30, 15W-40.

1. Remove the oil pressure sender and then install a mechanical oil pressure gauge in its place.
2. Start the engine and let it thoroughly warm up.
3. Check for oil leaks at the filter and pump assembly.
4. Maintain the engine rpm at 3,000 and note the gauge reading.

Oil Pressure:

4.1 – 4.9 kg/cm² (58 – 70 lb/in²)

5. If the pressure does not come up to the specified pressure, check the lubrication system and repair if necessary (see *ENGINE TROUBLESHOOTING*).

A gradual loss of oil pressure usually indicates a specific bearing failure. For additional information on low oil pressure readings, see "OIL PRESSURE DROP" under "ENGINE TROUBLESHOOTING."

ENGINE ADJUSTMENTS

TESTING FUEL INJECTORS

Using a nozzle tester, check the injection starting pressure of the nozzle, and if it exceeds the limit, adjust or replace the nozzle.

NOTE: *The fuel injectors must be serviced in a clean room environment.*

Removing the Fuel Injectors

1. Disconnect the high pressure lines from the injectors, then loosen the lines at their attachment to the injection pump and move them out of the way of the injectors. Avoid bending the lines.
2. Remove the fuel return line in its entirety from the top of the injectors. Take care not to lose the two sealing washers and banjo bolt that attaches the fuel return line to each injector.
3. Unscrew the injector from the cylinder head, using a 27 mm clamp socket.

NOTE: *Clean the area around the base of the injector prior to lifting it out of the cylinder head to help prevent any rust or debris from falling down into the injector hole. If the injector will not lift out easily and is held in by carbon build-up or the like, work the injector side-to-side with the aid of the socket wrench to free it, and then lift it out.*

4. The injector seats in the cylinder head on a copper sealing washer. This washer should be removed with the injector and replaced with a new washer when the injector is reinstalled.

Injection Testing

1. Set the nozzle tester in a clean place where there is no dust or dirt.
2. Mount the nozzle and nozzle holder on the nozzle tester.
3. Use new fuel that has an approximate temperature of 20°C (68°F).
4. Operate the hand lever of the nozzle tester several times to bleed the air in the nozzle line, then move the hand lever at intervals of one stroke per second while reading the injection starting pressure.
5. If the diesel fuel of the nozzle tester is stained, replace the fuel. At the same time, clean or replace the fuel filter.

CAUTION: *The spray injected from the nozzle is of such velocity that it may penetrate deeply into the skin of the fingers and hands, destroying tissue. If it enters the bloodstream, it may cause blood poisoning.*

6. Check the spray pattern and injection starting pressure of the nozzle and, if the injection starting pressure exceeds the limit, adjust or replace the nozzle.

Injection starting pressure:
135 – 140 kg/cm² (1920-1990 lb/in²)

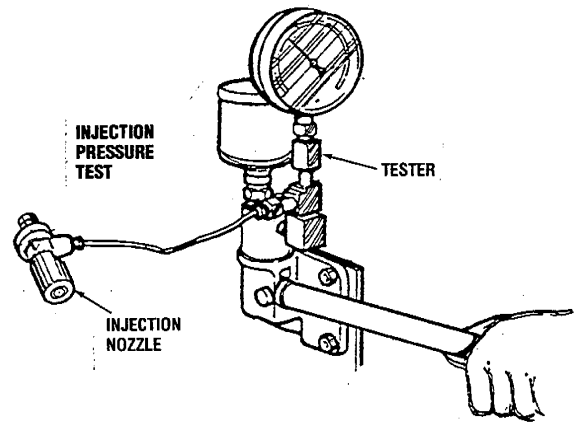

7. If the injection starting pressure of the nozzle is not within the limit, loosen the cap nut on the nozzle holder, insert a flat screwdriver through the bolt hole of the cap nut, then turn the pressure adjusting screw to set the injection starting pressure to 200 kg/cm² (2.844 lb/in²). Then, gradually decrease the pressure until the injection starting pressure is 135 kg/cm² (1920 lb/in²).

After the injection starting pressure has been adjusted, hold the pressure adjusting screw with a flat screwdriver, then tighten the cap nut. Then check the injection starting pressure again if it does not change.

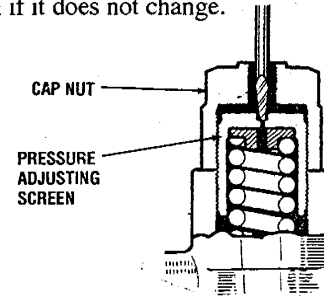

Inspecting the Spray Pattern.

1. Operate the hand lever of the nozzle tester at intervals of one stroke per second to check if the fuel is injected correctly in its axial direction. A nozzle is defective if it injects fuel in an oblique direction or in several separate streams. Also, a spray in the form of particles indicates a defect. These defects may sometimes be caused by clogging with dust, therefore all parts should be carefully cleaned before reassembly. (Care should be taken not to expose one's skin to this spray as it may penetrate the skin and cause infection.)

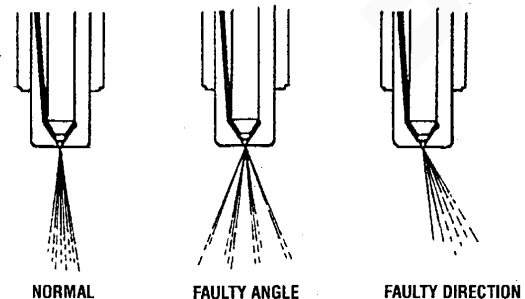

ENGINE ADJUSTMENTS

- Apply a pressure of 115 kg/cm² (1635 lb/in²) to the nozzle by operating the hand lever, and check the drips from the nozzle tip. If it drips or has a large accumulation of fuel on the bottom, it is considered defective and should be replaced. A very small amount of fuel may sometimes remain on the tip of the nozzle, however, this does not indicate a defect.

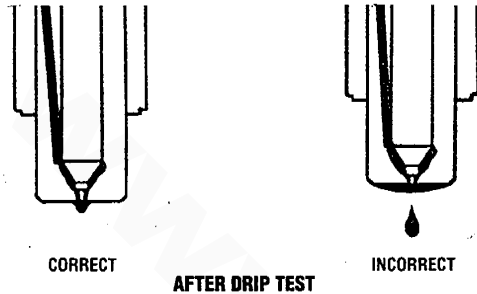

Injector Disassembly

- Clamp the nozzle holder in a vise, then remove the cap nut.
- Remove the pressure adjusting screw, then pull out the upper seat, the spring and the push rod.
- With the nozzle holder in the vise, remove the nozzle nut, then pull the nozzle out.

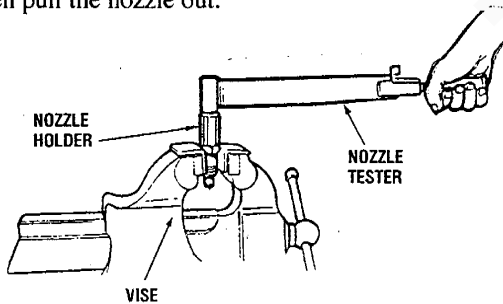

NOTE: The greatest possible care should be taken when handling the nozzles, as they are very precisely machined. The nozzle and the needle valve are matched pairs — do not mix their original combinations.

Injector Inspection

- Disassemble and clean each nozzle assembly separately. Clean the disassembled parts with clean diesel fuel, then remove the carbon adhering to the nozzle with a piece of hard wood. Do **not** use a metal tool to remove the carbon.

NOTE: It is advisable not to clean the surrounding area of the nozzle orifice, to avoid possible damage to the orifice.

Iron dust on the magnetic filter top must be completely removed.

- After cleaning, set the nozzle body in an upright position, insert the needle valve, then check to make sure the needle valve comes down into the valve seat by its own weight. If it does not, replace the entire nozzle assembly.

- Check that there are no flaws or other damage on mating surfaces and the sliding surfaces of the nozzle body and needle valve; if any are present, replace the nozzle assembly.

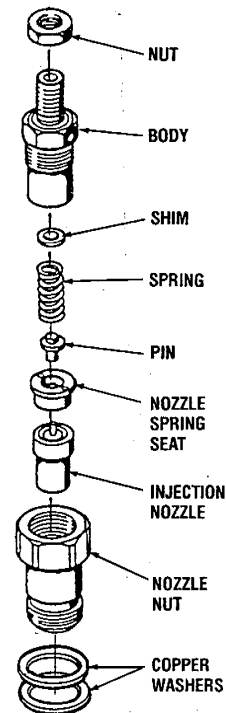

FUEL INJECTOR

Injector Reassembly

To reassemble, reverse the order of disassembly, and include the following:

- To assemble the nozzle and nozzle holder, first assemble the pressure adjusting nut side, and temporarily tighten the nut. Mount the nozzle and set the needle valve to its proper position, then mount the nozzle nut.

Nozzle nut tightening torque:

8 – 10 kg-m (58 – 72 ft-lb)

Cap nut tightening torque:

4 – 5 kg-m (29 – 36 ft-lb)

- After the nozzle and nozzle holder have been assembled, check the injection starting pressure and spray condition.

Injector Installation

- Use new copper washers when installing the injectors.
- Tighten the injectors to the specified torque.

Injectors tightening torque:

1.6 – 2.4 m-k (11.6 – 17.4 ft-lb)

ENGINE ADJUSTMENTS

IDLE SPEED ADJUSTMENT

Checking the Idle Speed

1. Warm up the engine to normal operating temperature.
Remove any specks on the crankshaft pulley with a clean cloth and place a piece of suitable reflecting tape on the pulley to facilitate use of a photoelectric type tachometer.
2. Start and idle the engine.
3. Aim the light of the tachometer onto the reflecting tape to confirm the engine speed.
4. Adjust the idle speed if the engine speed is not within the specified value.

Normal Idle Speed: 750 – 1000 rpm

Adjusting the Idle Speed

1. Loosen the locknut on the idle adjustment bolt on the fuel injection pump.
2. Turn the idle adjustment bolt until the idling speed is within the standard range.
3. Tighten the locknut.
4. Race the engine several times to ensure the idle speed remains as set.

NOTE: Should engine rpm be in question, verify the tachometer readings as shown at the instrument panel with a mechanical or strobe-type tachometer at the engine crankshaft.

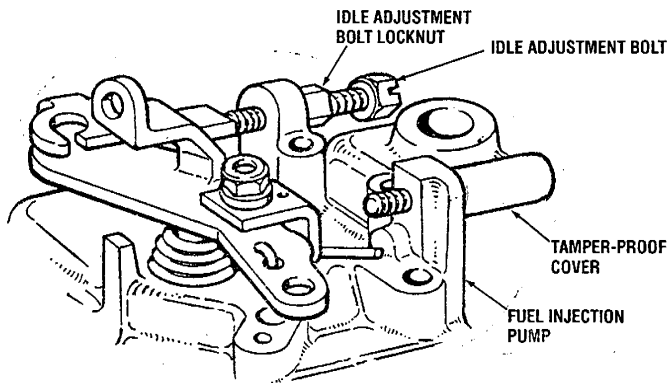

ADJUSTING IDLE SPEED

ENGINE ADJUSTMENTS

INJECTION PUMP TIMING ADJUSTMENT

Disassembly

1. Remove the air intake silencer assembly.
2. Remove the four high pressure injector lines that connect the injection pump with the injectors.
3. Remove the bolt and gasket installed on the distributor head of the injection pump.
4. Remove the valve rocker cover.
5. Rotate the crankshaft in its normal direction of rotation (use the front crankshaft pulley nut) and place the No. 1 piston at TDC of its compression stroke.

NOTE: To verify, the rocker arms of No. 4 cylinder should be rocking (one opening, the other closing).

6. Remove the snap ring circlip from the end of the rocker shaft at cylinder No. 1 along with the retaining washer.
7. Loosen the rocker arm adjusting bolt to allow the arm to be removed from the push rod, and slide it off the rocker shaft.
8. Press down on the valve and spring assembly and note that the valve is hitting the top of No. 1 piston. Then remove the cap, keepers and valve springs from the No. 1 valve.

NOTE: Insure the valve moves freely in its guide. Take care not to drop the keepers down the push rod hole.

Inspection

1. Position a dial indicator gauge on the valve stem, and using the front crankshaft pulley nut, rock the crankshaft counterclockwise and clockwise to locate exact TDC of the compression stroke for the No. 1 piston, and then zero the dial indicator gauge to the valve stem. (The gauge should be able to measure up to .300 inch of valve movement.)

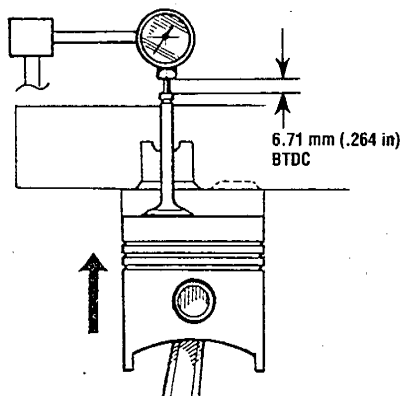

2. Turn the crankshaft until the indicator shows the valve drop to be at .264 inch. This is 30° BTDC.
3. Install the measuring device (Diesel Kit #57828 - 3520) in the bolt hole of the injection pump distributor head, (refer back to step 3. under *Disassembly*) Insure that the

feeler needle of the measuring device is in contact with the plunger inside the pump. Zero the measuring device scale.

4. Turn the crankshaft in the direction of normal rotation until the No. 1 piston is at TDC by referencing the indicator on the valve stem.

The measuring device indicator needle should move 1.00 mm from the zero setting.

Beginning of Static Injection

Cam lift 1.00 mm (0.0394 in)

NOTE: If the measuring device shows movement at the plunger to be more or less than specified above, the injection pump must be adjusted to correct the movement.

Timing Adjustment

1. Disconnect the fuel supply and return line connections from the injection pump.
2. Disconnect the support bracket at the back of the injection pump where it attaches to the lube oil filter adapter.
3. Loosen the two injection pump hold-down nuts that secure the injection pump to the engine.
4. Rotate the injection pump either toward the engine or away from the engine to adjust the measuring device indicator to show 1.0 mm of movement.
5. Secure the pump by tightening the two hold-down nuts.
6. Remove the measuring device, replace the bolt and gasket, and reattach all fuel lines using a new sealing washer.

Reassembly

To reassemble, reverse the order of disassembly, and include the following:

1. Tighten the lock nut of the injection pump drive gear to the specified torque.

Injection pump tightening torque:

4.0 - 7.4 kg-m (29 - 51 ft-lb)

2. After the injection pump has been installed, loosen the overflow valve, and bleed the air by operating the priming pump.

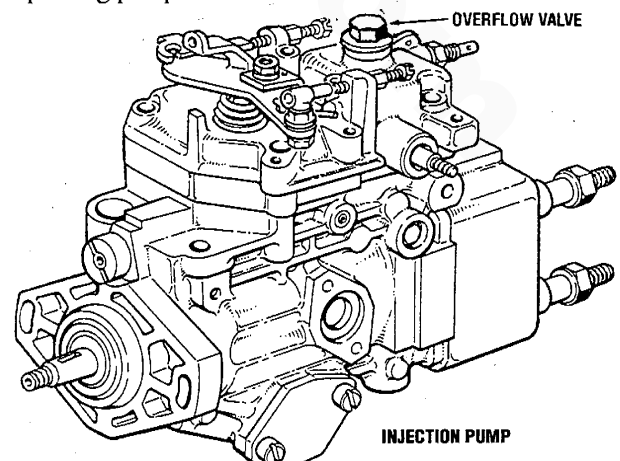

GLOW PLUGS

DESCRIPTOIN

The glow plugs are wired through the preheat solenoid.

When PREHEAT is pressed at the control panel this solenoid should "click" on and the glow plugs should begin to get hot.

INSPECTION

To inspect the plug, remove the electrical terminal connections, then unscrew or unclamp each plug from the cylinder head. Thoroughly clean each plug's tip and threads with a soft brush and cleaning solution to remove all the carbon and oil deposits. While cleaning, examine the tip for wear and burn erosion; if it has eroded too much, replace the plug.

TESTING

An accurate way to test glow plugs is with an ohmmeter. Touch one prod to the glow plug's wire connection, and the other to the body of the glow plug, as shown in the illustration. A good glow plug will have a 1.0 – 1.5 ohm resistance. This method can be used with the plug in or out of the engine. You can also use an ammeter to test the power drain (8 to 9 amps per plug).

WARNING: *These glow plugs will become very hot to the touch. Be careful not to burn your fingers when testing the plugs.*

Reinstall the plugs in the engine and test them again. The plugs should get very hot (at the terminal end) within 20 to 25 seconds. If the plugs don't heat up quickly, check for a short circuit. When reinstalling the glow plugs, use anti-seize compound on the threads.

WARNING: *Do not keep a glow plug on for more than 30 seconds.*

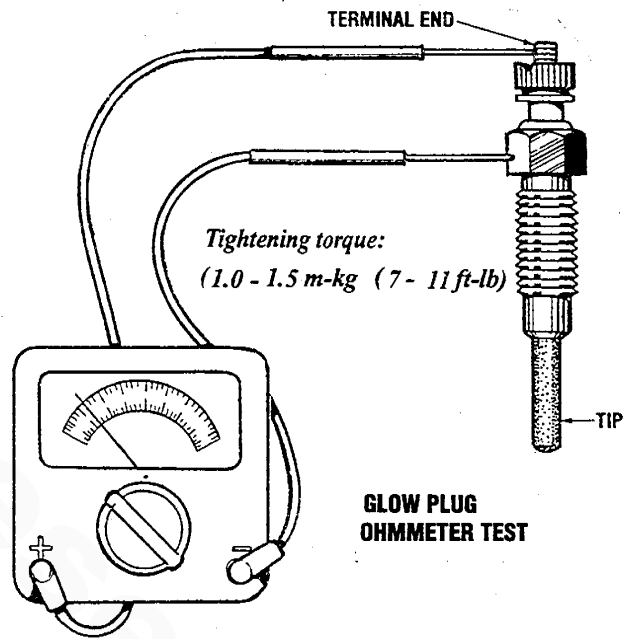

LUBRICATION SYSTEM

GENERAL DESCRIPTION

The oil pump is the crescent type, directly driven by the crankshaft. The oil cooler is water-cooled. Oil jets are provided to cool the pistons.

OIL PAN

Disassembly

1. Mount the engine on a suitable engine stand.
2. Drain the engine oil.
3. To remove the oil pan and its gasket, remove the oil pan mounting bolts, then insert a flat-tipped scraper between the oil pan and the cylinder block to separate them.

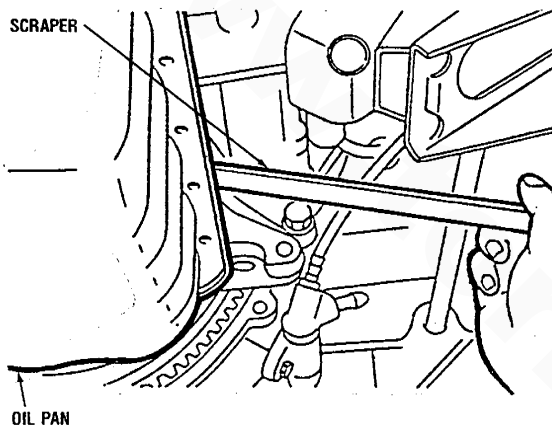

Inspection

Check for the following conditions, and repair or replace the oil pan if necessary.

1. Cracks, deformation, damage (at bolt locations).
2. Damaged drain plug threads.

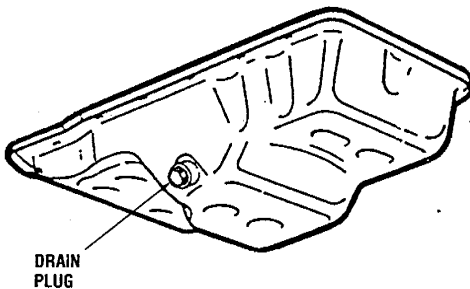

Reassembly

1. After cleaning the surfaces where the oil pan and the cylinder block meet, apply *PERMATEX* sealant (or equivalent) to the oil pan, as shown in the illustration, and then install the oil pan.

NOTE: Tighten the oil pan bolts within 30 minutes after application of the sealant.

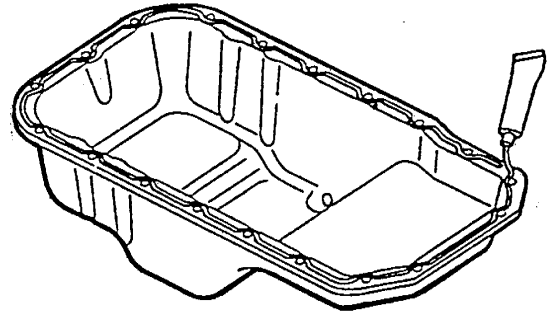

2. If a gasket is used, apply *PERMATEX* sealant (or equivalent) to the areas indicated by the arrows in the illustration after first cleaning the surface where the oil pan meets the cylinder block.

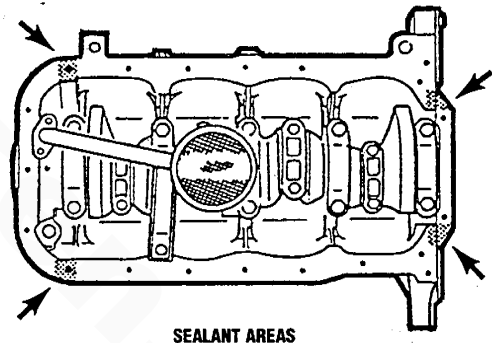

LUBRICATION SYSTEM

OIL PUMP

Removal

1. Mount the engine on a suitable engine stand.
2. After draining the engine oil, remove the parts in the numbered sequence as shown in the illustration.

NOTE: The installation sequence of these parts is the reverse of the removal sequence.

2. Loosen the screws by an impact driver or similar tool so that the oil pump body is not damaged.

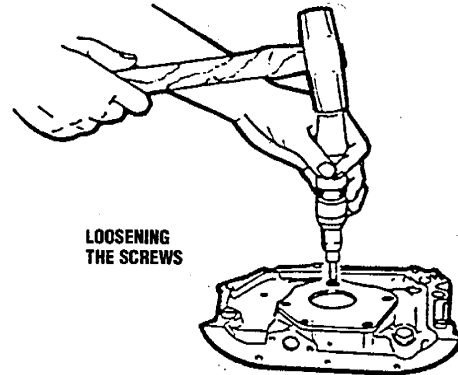

LOOSENING THE SCREWS

Inspection

1. Check for the following conditions, and repair or replace the oil pump if necessary.
 - a. Distortion or damage to the pump body or cover.
 - b. Worn or damaged plunger.
 - c. Weak or broken plunger spring.
2. Measure the gear clearances:

Outer gear tooth tip to crescent clearance limit:
0.35 mm (0.013 in)

Inner gear tooth tip to crescent clearance limit:
0.35 mm (0.013 in)

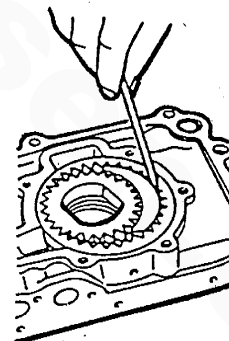

OUTER GEAR TO CRESCENT CLEARANCE

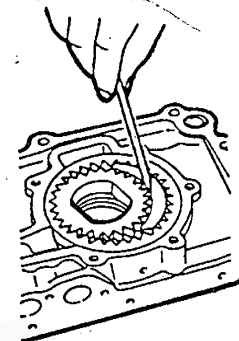

INNER GEAR TO CRESCENT CLEARANCE

3. Measure the side clearance.

Side clearance limit:
0.15 mm (0.006 in)

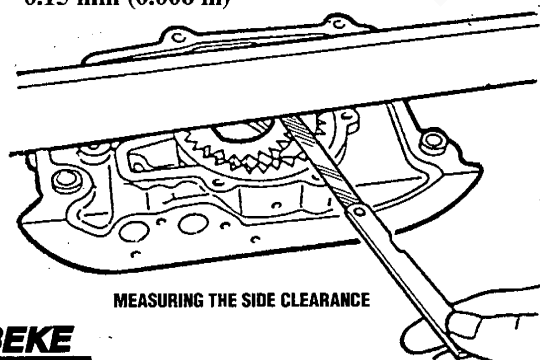

MEASURING THE SIDE CLEARANCE

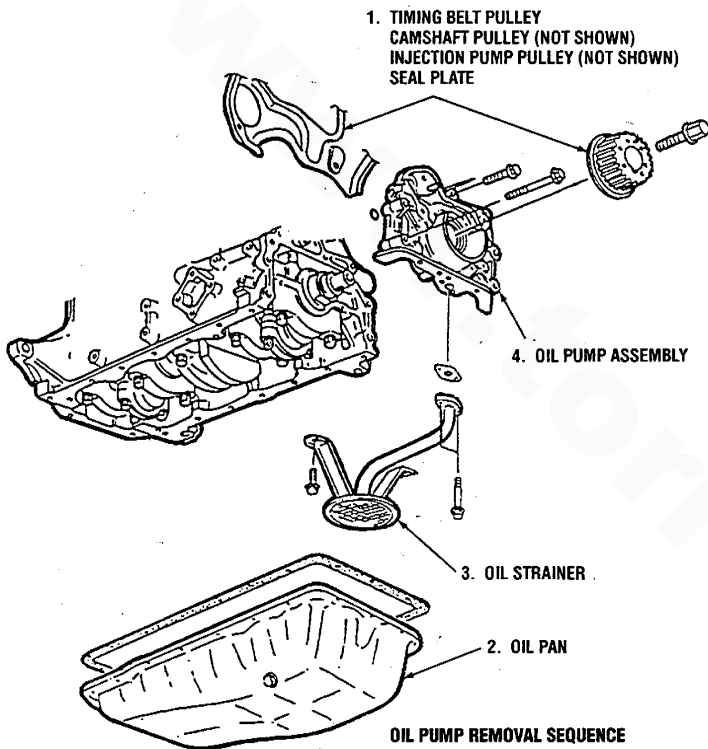

OIL PUMP REMOVAL SEQUENCE

Disassembly

1. Disassemble the oil pump in the numbered sequence shown in the illustration.

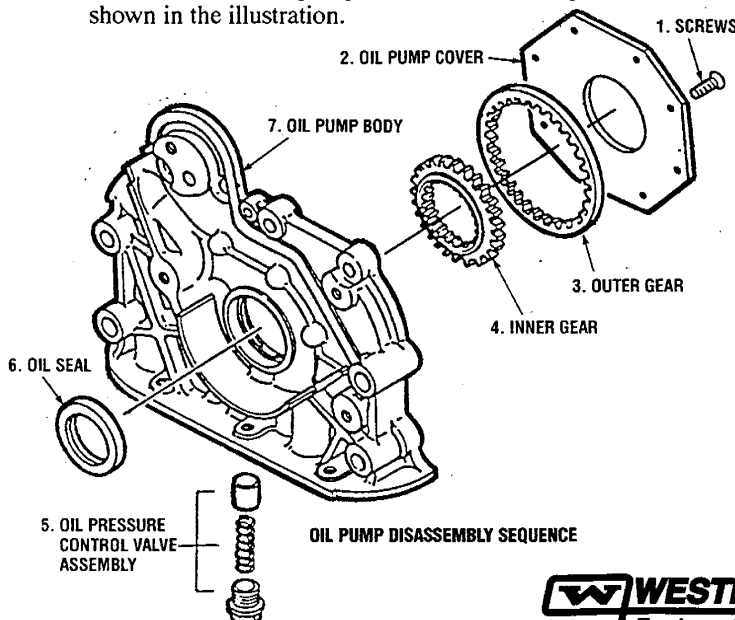

OIL PUMP DISASSEMBLY SEQUENCE

LUBRICATION SYSTEM

4. Measure the body clearance.

**Outer gear to pump body clearance limit:
0.20 mm (0.008 in)**

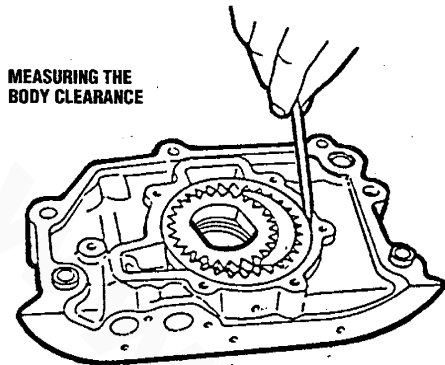

5. Oil Seal Replacement

- a. Remove the oil seal by using a screwdriver or similar tool to pry it out.
- b. Press in the new oil seal by using a pipe or round rod with an outer diameter of 45 mm (1.77 in).

CAUTION: Press the oil seal in until the front end is aligned with the front end of the pump body.

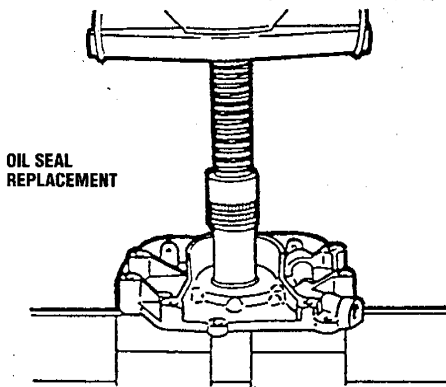

Reassembly

The reassembly sequence is the reverse of the disassembly sequence, and should include the following:

1. Install the outer gear with the mark indicated by the punch holes facing toward the oil pump cover.
2. Apply a thin coating of grease to the O-ring, and position it at the location shown in the illustration.
3. Apply a coat of *PERMATEX* sealant (or equivalent) to the oil pump surface shown by the shading in the illustration.

NOTE: Be careful not to let the sealant get into the oil hole.

4. Coat the oil seal lip with engine oil, then install the seal, taking care not to damage the lip.

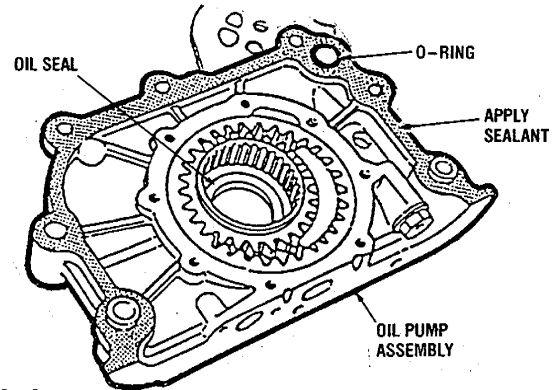

Installation

The installation sequence is the reverse of the removal sequence

OIL COOLER

Disassembly

With the coolant drained, remove each part in the numbered sequence shown in the illustration.

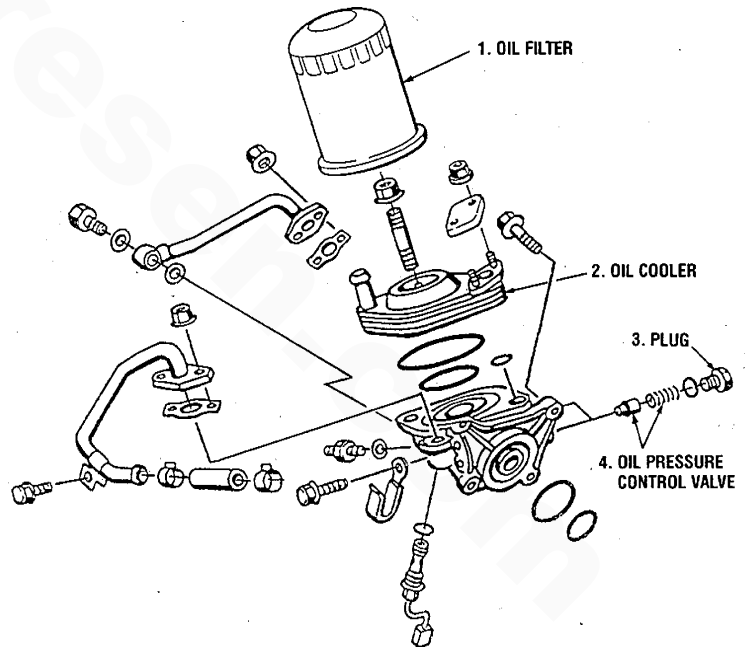

Inspection

Replace all O-rings. Apply engine oil to the new O-rings.

LUBRICATION SYSTEM

Reassembly

The reassembly sequence is the reverse of the disassembly sequence.

When installing the oil cooler, align the oil cooler holes with the projections on the oil filter body.

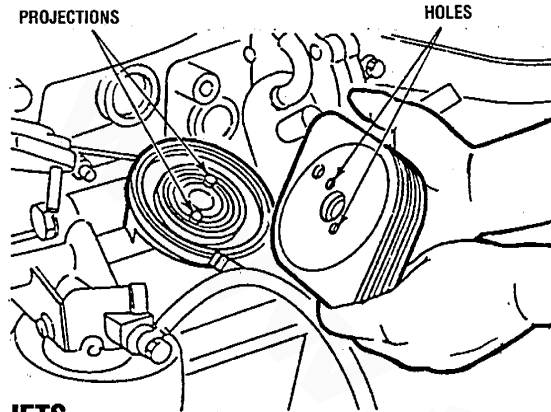

OIL JETS

Removal

Remove each part in the following sequence:

1. Remove the oil pan (see the *OIL PAN* section).
2. Remove the oil jet valves.
3. Remove the oil jets.

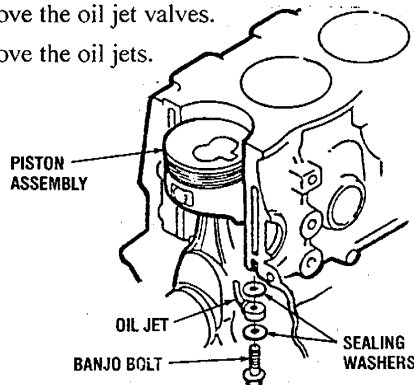

Inspection

1. Make sure that the oil passage is not clogged.
2. Check and ensure that the spring inside the oil jet valve is not stuck or damaged.

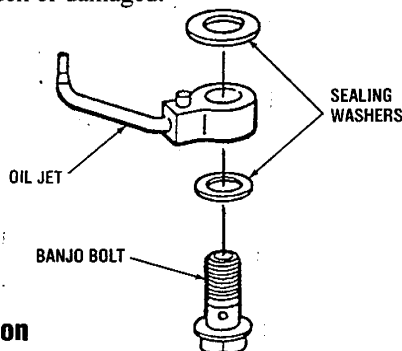

Installation

The installation sequence is the reverse of the removal sequence.

OIL PRESSURE SWITCH & OIL PRESSURE SENDER

1. The engine has a two-prong oil pressure/water temperature switch. The oil pressure switch is normally open; it closes when the oil pressure rises to 5 – 10 psi.

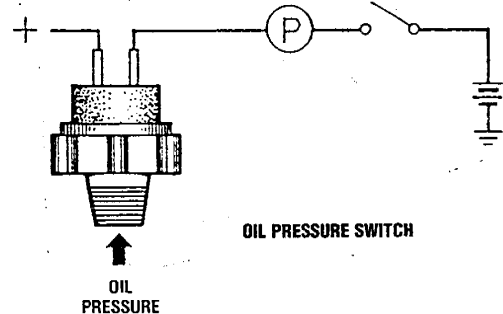

When the oil pressure drops to 5 – 10 psi (too low), this switch interrupts the circuit for the fuel run solenoid by opening, thereby shutting down the engine. This switch also activates an alarm that emits a pulsating signal when the oil pressure drops to 5 – 10 psi.

NOTE: This alarm will also emit a pulsating signal when the engine starts up, as the oil has not yet reached its normal pressure (a good check of the alarm).

When performing an engine overhaul, replace the oil pressure switch and the oil pressure sender. When installing the new parts, apply a teflon sealant to the threaded ends, being careful not to close off the oil hole in the sender.

Oil pressure switch and sender torque:
1.2 – 1.8 kg-m (9 – 13 ft-lb)

CAUTION: Oil pressure switch — Do not use lock pliers, vise grips or pipe wrenches on the oil pressure switch. Use the correct socket which is available from Snap-On, Proto, New Britain and others. Damage to the switch will cause oil leaks and/or switch failure.

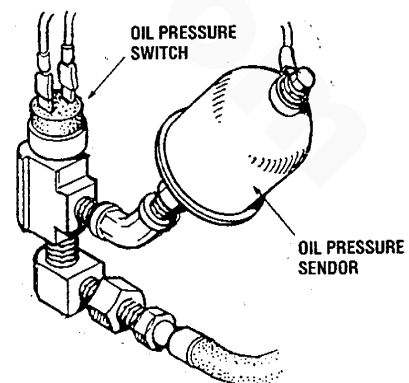

LUBRICATION SYSTEM

TESTING THE OIL PRESSURE

NOTE: Insure that the oil meets the following standards: API Specification CF or CG-4, SAE 30, 10W-30, 15W-40.

1. Remove the oil pressure sender and then install a mechanical oil pressure gauge in its place.

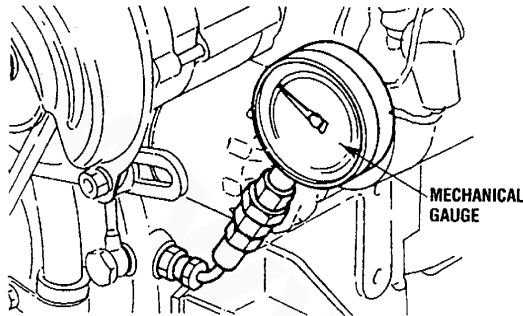

TESTING THE OIL PRESSURE

2. Start the engine and let it thoroughly warm up.
3. Check for oil leaks at the filter and pump assembly.
4. Maintain the engine rpm at 3,000 and note the gauge reading.
5. If the pressure does not come up to the specified pressure, check the lubrication system and repair if necessary (see *ENGINE TROUBLESHOOTING*).

Oil pressure:

4.1 – 4.9 kg/cm² (58 – 70 lb/in²)

A gradual loss of oil pressure usually indicates a specific bearing failure. For additional information on low oil pressure readings, see *OIL PRESSURE DROP* under *ENGINE TROUBLESHOOTING*.

REMOTE OIL FILTER (Optional)

INSTALLATION

This popular accessory is used to relocate the engine's oil filter from the engine to a more convenient location such as an engine room bulkhead.

NOTE: Refer to *ENGINE OIL CHANGE* in this manual for instructions on removing the oil filter.

To install, simply remove the engine oil filter and thread on WESTERBEKE's remote oil filter kit as shown. Always install this kit with the oil filter facing down as illustrated.

Contact your WESTERBEKE dealer for more information.

NOTE: *Westerbeke is not responsible for engine failure due to incorrect installation of the Remote Oil Filter.*

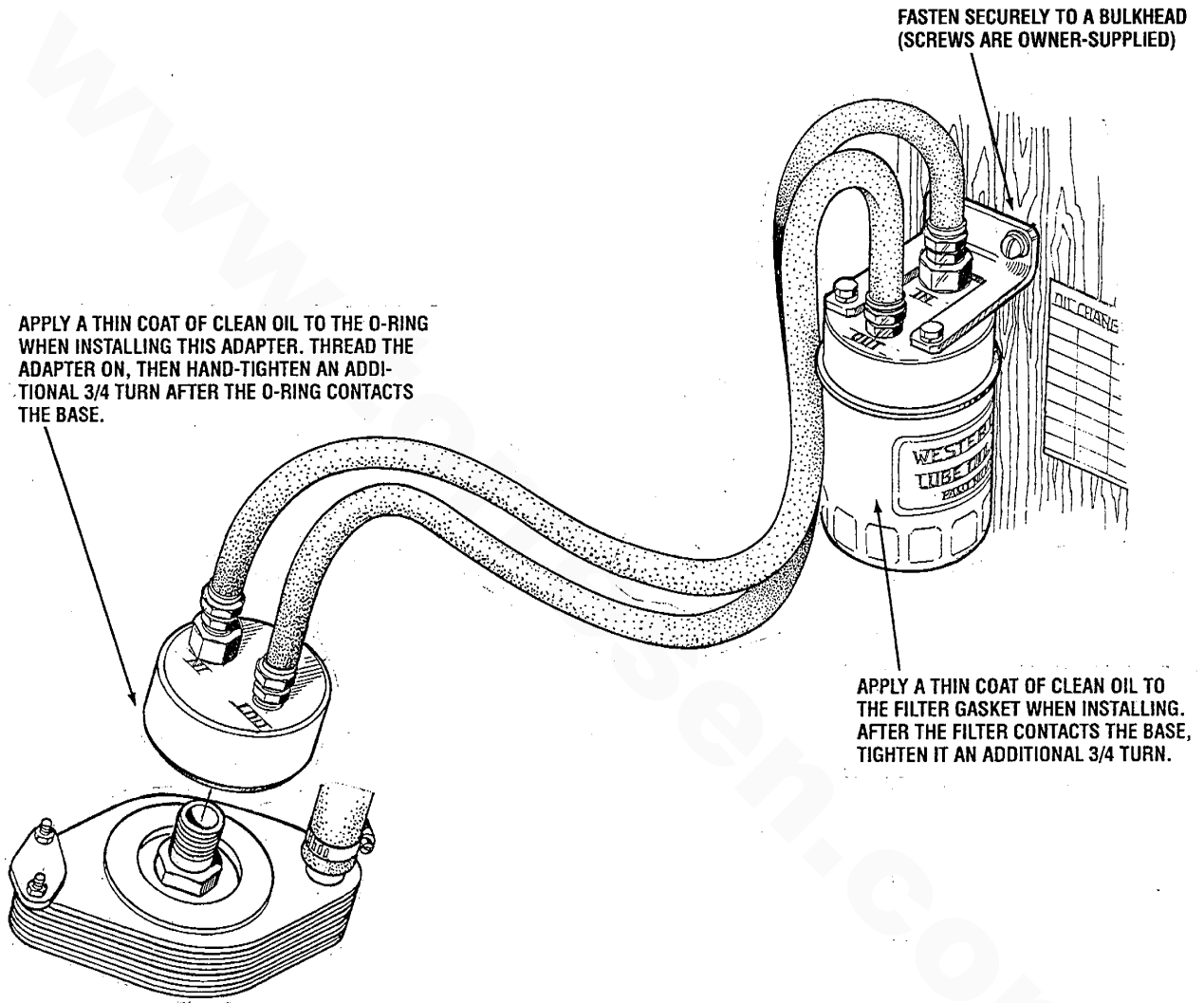

COOLANT PUMP

REMOVAL

1. Turn the crankshaft so that the No. 1 cylinder is at TDC (top dead center) of compression.
2. Drain the engine coolant into a suitable container.
3. Remove the following components in the order listed:
 - a. Alternator drive belt.
 - b. Alternator.
 - c. Coolant Hose.
 - d. Crankshaft pulley.
 - e. Upper and lower timing belt covers.
 - f. Timing belt tensioner and spring.
 - g. Timing belt.
 - h. Coolant pump and alternator strap.

DISASSEMBLY

Remove the pump cover and the gasket.

CAUTION: Do not disassemble the coolant pump body. Replace it as an assembly if necessary.

INSPECTION

Replace the cover gasket.

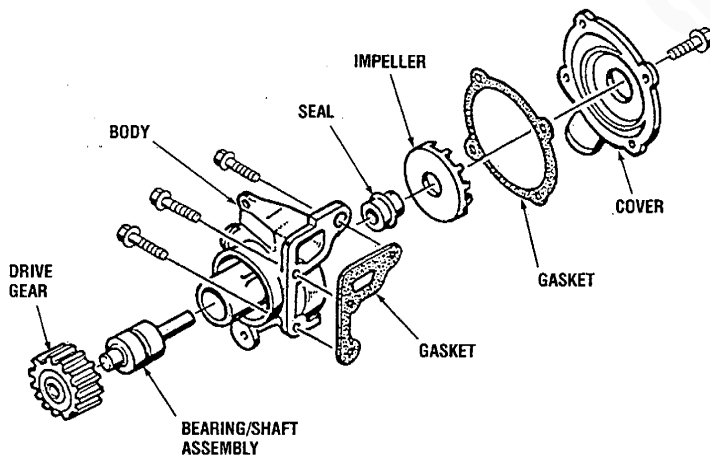

REASSEMBLY

Reassemble the pump cover with its new gasket.

INSTALLATION

The installation sequence of the coolant pump and the other components that were removed is the reverse of the removal sequence.

Coolant pump tightening torque:

3.2 – 4.7 kg-m (23 – 34 ft-lb)

After installing the coolant pump, fill the cooling system with coolant and operate the engine to check for leaks.

RAW WATER PUMP

PUMP OVERHAUL

Disassembly

The pump, as removed from the engine, will have hose attachment nipples threaded into its inlet and outlet port. They may be left in place or removed if they interfere with the pump disassembly. Note the port location and positioning if removed.

1. Loosen the set screw with an allen wrench and remove the water pump pulley from the shaft
2. Remove the 4 cover plate screws, cover plate, and cover gasket.

NOTE: Replacement of the cover plate gasket is recommended; however, if you are going to reuse it, keep the gasket well lubricated until the pump is reassembled. If it's allowed to dry, the gasket will shrink and not be reusable.

3. Pull out the impeller with long nose pliers or pry out with a pair of screwdrivers.
4. Remove the two screws that hold the bearing assembly, this will release the shaft, bearing and seal assembly. Removing the retaining rings will allow the bearings and seals to be disassembled for inspection.

NOTE: It may be necessary to use a drift and arbor press to press the bearing and seal assembly from the shaft.

6. Inspect all parts and replace those showing wear or erosion.
7. Use the illustration below to assist in reassembling the raw water pump.
 - a. apply a small amount of petroleum jelly to the seal's inner race and to the impeller shaft at reassembly.
 - b. When positioning the cam in the housing use a small amount of Permatex #1 on the inner cam surface and cam screw threads, remove any excess from the impeller housing.
 - c. Apply a light film of silicone or petroleum jelly to the inner surface of the housing for the impeller.
8. When the pump is assembled reposition and tighten the hose nipples. Assemble the pump to the engine and attach the hoses and belt.

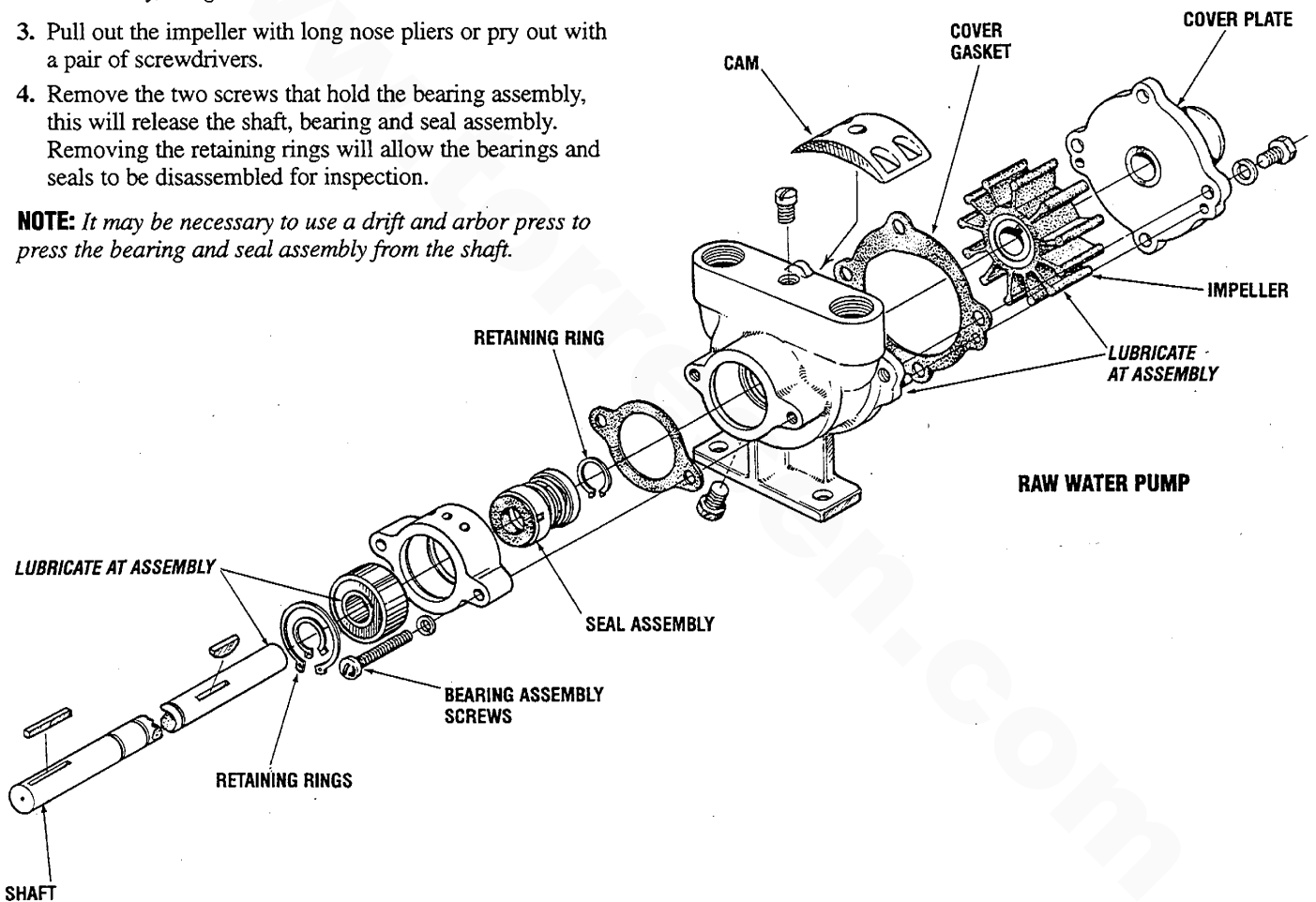

HEAT EXCHANGER

The heat exchanger should be inspected and serviced during an engine overhaul.

DISASSEMBLY

1. Disconnect the hoses and remove the hose fittings, drain plugs and zinc anodes. Also remove the end fittings and gaskets.

INSPECTION

1. Inspect the tube (casing) for wear and dents. Replace the heat exchanger if there is any doubt about its performance.
2. Clear out any zinc debris, and pressure test the coolant and raw water passages.

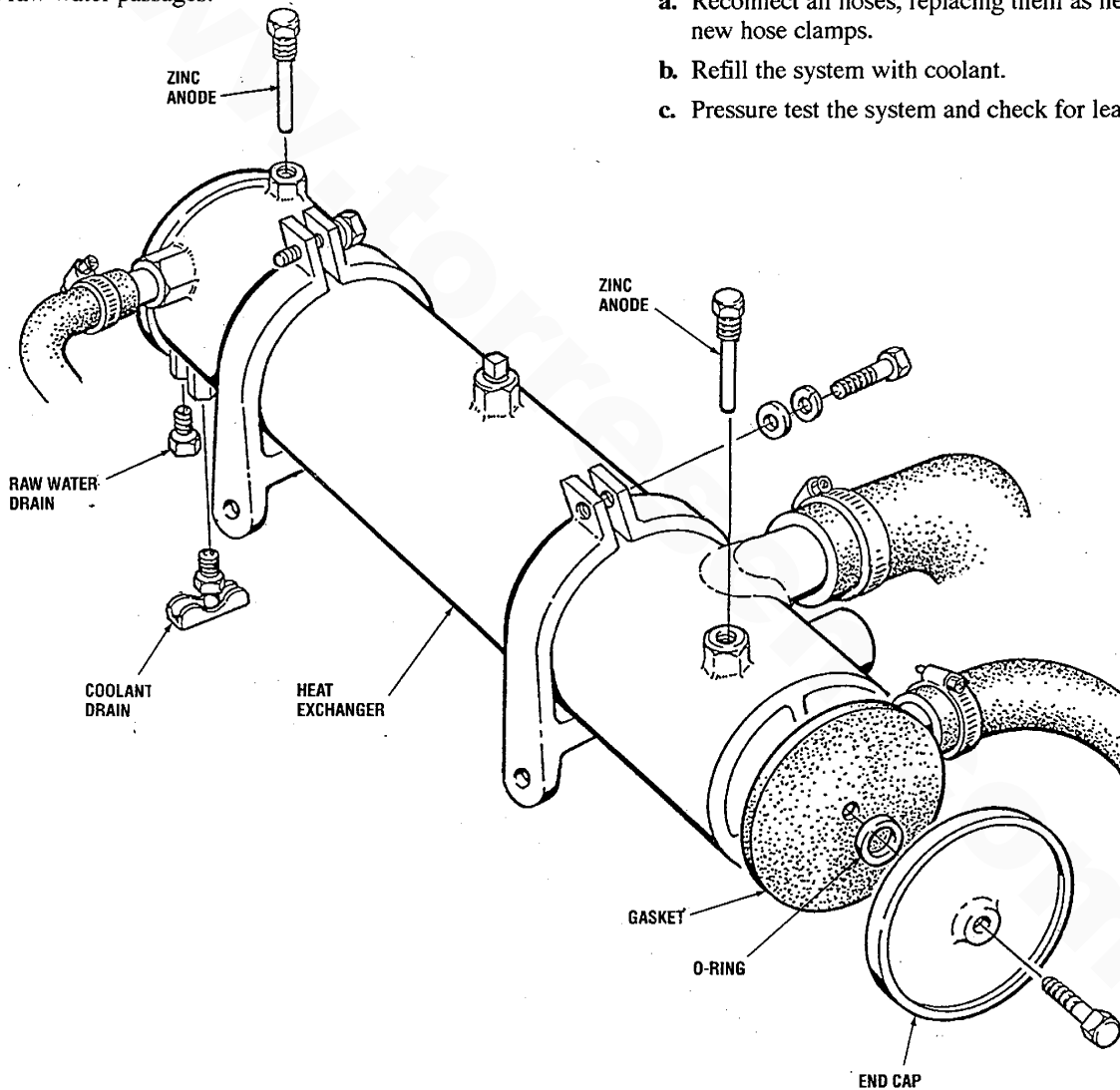

REASSEMBLY

1. When reassembling, install new gaskets and O-rings. Apply some lubricant to the new gaskets and to the pet-cock and fittings as you install them.

2. Install a new zinc anode.

NOTE: All of the above service can be accomplished by sending the heat exchanger to a heat exchanger service shop. They will also service transmissions and engine oil coolers.

3. Repaint the assembled heat exchanger with WESTER-BEKE heat resistant spray enamel.

4. To ensure that the above heat exchanger service is satisfactory, follow this procedure:

- a. Reconnect all hoses, replacing them as needed; use new hose clamps.

- b. Refill the system with coolant.

- c. Pressure test the system and check for leaks.

INTAKE/EXHAUST MANIFOLD

DISASSEMBLY

1. Unclamp the exhaust elbow, the two coolant hoses on the exhaust manifold, and the coolant recovery tank hose. Be sure to note the positions of these components to ensure that they will be properly aligned during reassembly.
2. Remove the single hex bolt that attaches the air intake to the exhaust manifold, then remove the air intake and the dual air filters.
3. Remove the exhaust manifold and its gaskets from the cylinder head.
4. Remove the manifold pressure cap.
5. Remove the manifold drain plug.

INSPECTION

1. Use a liquid cleaner to flush out the exhaust manifold and to clean the intake manifold, then rinse both manifolds thoroughly with fresh water.
2. Clean and inspect the dual air filters; replace if necessary.
3. Clean and inspect the exhaust elbow for cracks and defects; replace if necessary.
4. Check the manifold pressure cap. Open the valve by pulling it, and make sure it closes when released. Make certain the upper and lower seals are in good condition. If in any doubt, replace the cap.

5. Clean the passage that connects to the coolant recovery tank tubing.
6. Flush out the coolant recovery tank and its tubing.
7. Examine all other parts for defects, corrosion and wear, and replace as needed.

REASSEMBLY

1. Install the manifold drain plug.
2. Install the manifold pressure cap.
3. Place the manifold gaskets in position, using new gaskets. Do not use any gasket sealant.
4. Loosely attach the exhaust manifold to the cylinder head.
5. Gradually tighten, making sure all parts are properly aligned; do this in three steps. Tighten to the specified torque.

Intake/exhaust manifold tightening torque:
2.2 – 2.7 m·kg (16 – 20 ft·lb)

6. Install the air intake and the dual air filters. When reassembling, make certain the filters are positioned properly, and do not overtighten when refastening the bolt.
7. Attach the exhaust elbow, the two exhaust manifold hoses, and the coolant recovery tank hose.
8. Repaint the reassembled intake/exhaust manifold with WESTERBEKE heat resistant spray enamel.

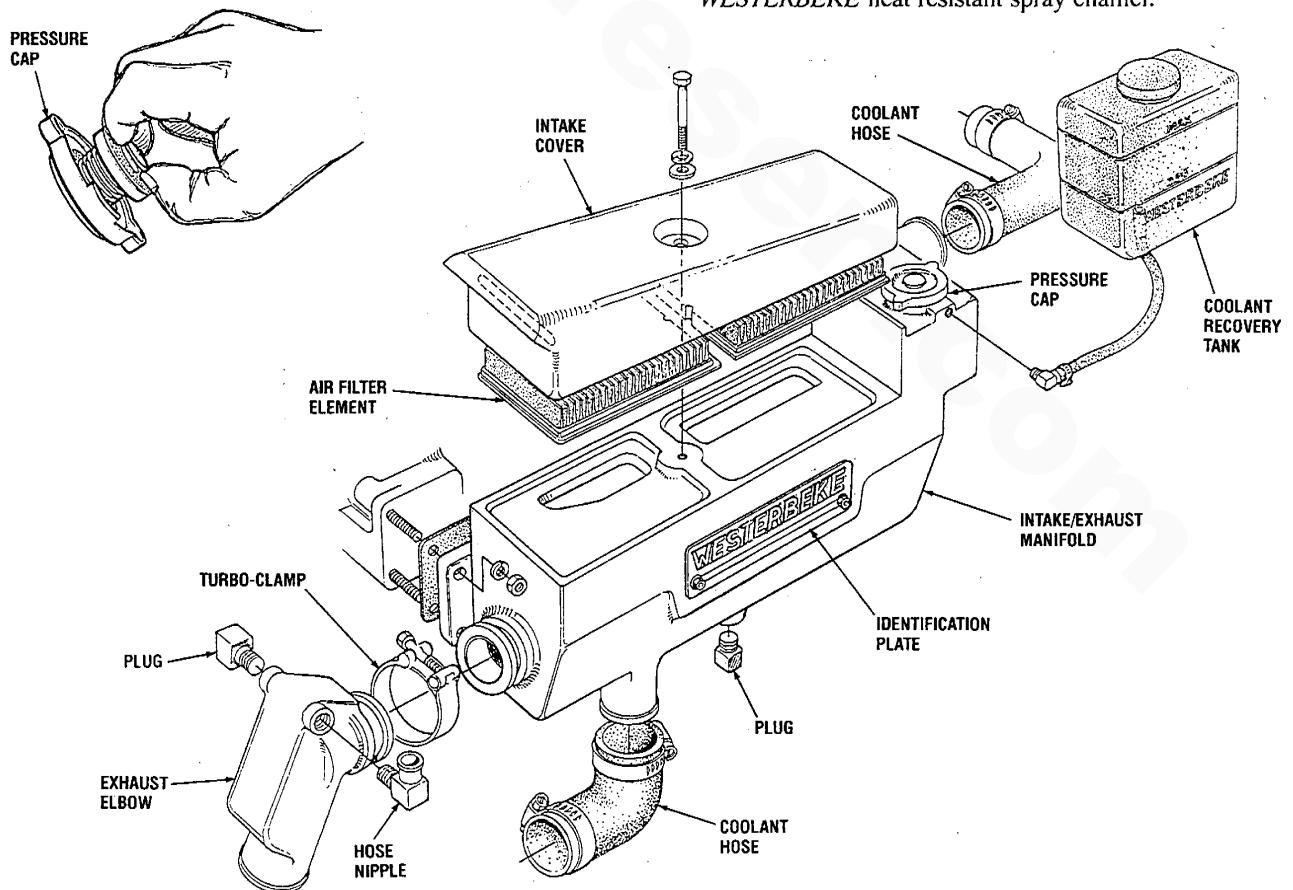

WESTERBEKE
Engines & Generators

TACHOMETER

TACHOMETER/HOURMETER

The tachometer/hourmeter used in propulsion engine instrument panels contains two separate electrical circuits with a common ground. One circuit operates the hourmeter and the other the tachometer. The hourmeter circuit operates on 12 volts alternator charging voltage supplied to the (+) terminal on the back of the instrument.

The tachometer circuit operates on AC voltage 6-8 volts, fed from one of the diodes in the alternator and supplied to the tachometer input terminal while the engine is running, and the alternator producing battery charging voltage 13.0-14.8 volts DC.

Use the following procedures when troubleshooting a fault in either of the two circuits in a tachometer/hourmeter.

Hourmeter Inoperative

Check for the proper DC voltage between (+) and (-) terminals.

1. Voltage present – meter is defective – repair or replace.
2. Voltage not present – trace (+) and (-) electrical connections for fault. (Jump 12 volts DC to meter (+) terminal to verify the operation.)

Tachometer Inoperative

Check for the proper AC voltage between tachometer input terminal and the (-) terminal with the engine running.

1. Voltage present – attempt adjusting the meter through the calibration access hole. If no results, repair or replace the meter.
2. AC voltage not present – check for proper alternator DC output voltage.
3. Check for AC voltage at the tach terminal on the alternator to ground.
4. Check the electrical connections from the tachometer input terminal to the alternator connection.

Tachometer Sticking

1. Check for proper AC voltage between the tachometer input terminal and the (-) terminal.
2. Check for a good ground connection between the meter (-) terminal and the alternator.
3. Check that the alternator is well grounded to the engine block at the alternator pivot bolt.

Tachometer Inaccurate

1. With a hand-held tach on the front of the crankshaft pulley retaining nut or with a strobe-type tach, read the front crankshaft pulley rpm. Set the engine with a hand or strobe tach at 1500-1800 rpm.
2. Adjust the tachometer with a small Phillips type screwdriver through the calibration access hole in the rear of the tachometer. Zero the tach and bring it to the rpm set by the strobe or hand tach. (Verify the rpm at idle and at high speed 2500-3000 rpm). (Adjust the tach as needed.)

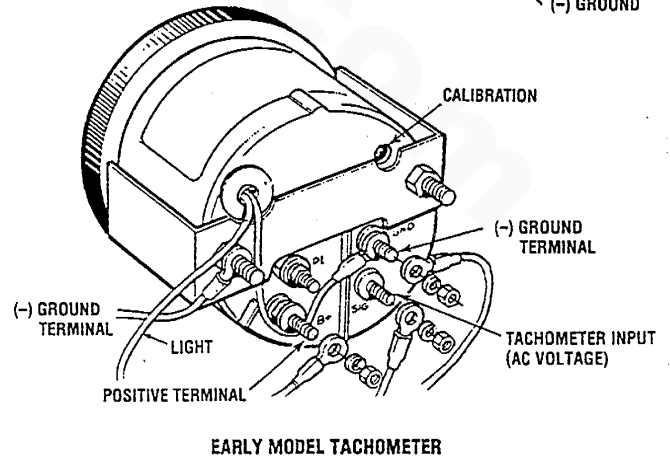
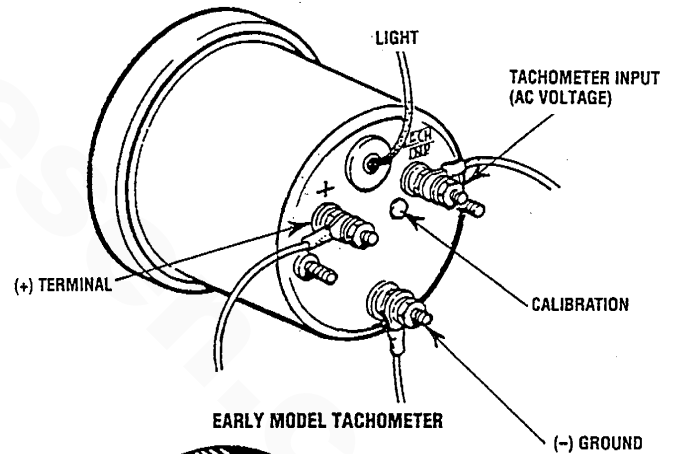
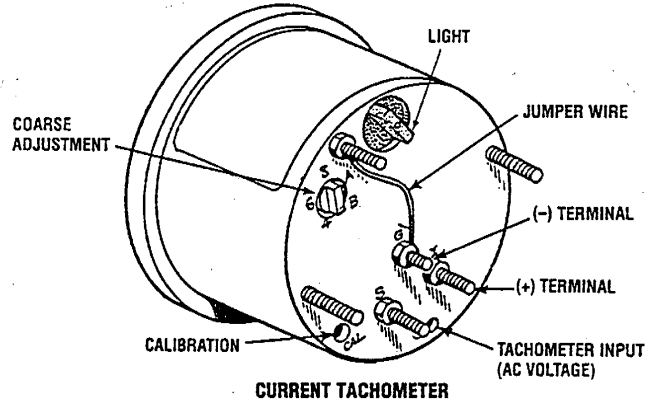

STARTER MOTOR

DESCRIPTION

The *starter* can be roughly divided into the following sections:

- A motor section which generates a drive power.
- An overrunning clutch section which transmits an armature torque, preventing motor overrun after starting.
- A switch section (solenoid) which is operated when actuating the overrunning clutch through a lever and which supplies load current to the motor.

The starter is a new type, small, light-weight and is called a high-speed internal-reduction starter. The pinion shaft is separate from the motor shaft; the pinion slides only on the pinion shaft. A reduction gear is installed between the motor shaft and a pinion shaft. The pinion sliding part is not exposed outside the starter so that the pinion may slide smoothly without becoming fouled with dust and grease. The motor shaft is supported at both ends on ball bearings. The lever mechanism, switch and overrunning clutch inner circuit are identical to conventional ones.

ADJUSTMENT AND REPAIR

If any abnormality is found by the following tests, the starter should be disassembled and repaired.

Pinion Gap Inspection

1. Connect a battery (12V) between the starter terminal S and the starter body, and the pinion drive should rotate out and stop.

CAUTION: Never apply battery voltage for over 10 seconds continuously.

2. Lightly push the pinion back and measure the return stroke (called pinion gap).
3. If the pinion gap is not within the standard range, (0.5 to 2.0 mm), adjust it by increasing or decreasing the number of shims on the solenoid. The gap is decreased as the number of shims increases.

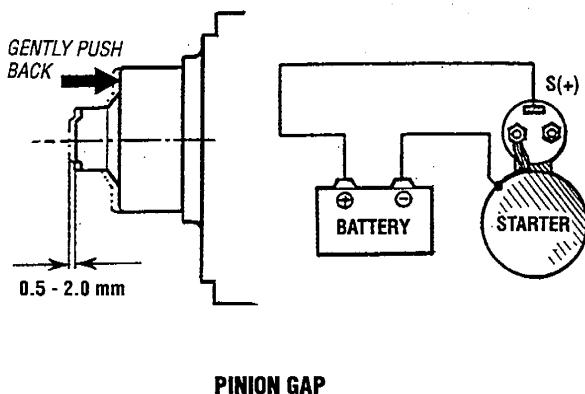

No-Load Test

1. Connect the ammeter, voltmeter, and battery to the starter as illustrated.
2. When the switch is closed, the pinion must protrude and the starter must run smoothly (at 3000 rpm or more). If the current or starter speed is out of specification, disassemble the starter and repair it.

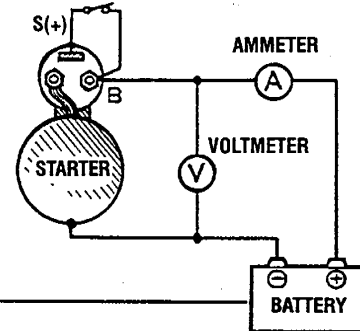

CAUTION: Use thick wires as much as possible and tighten every terminal securely. This is a solenoid shift-type starter which makes a rotating sound louder than that of a direct-drive type starter. When detecting starter rotation at the pinion tip, be careful not to come in contact with the pinion gear when it protrudes.

SOLENOID

Perform the following tests. If any test result is not satisfactory, replace the solenoid assembly.

1. Inspect the solenoid for continuity between terminals (+) and (-) and between terminals S and the body and M and the body. There should be no continuity found between terminals S and M. Continuity will be found between terminals S and the body and terminal M and the body.

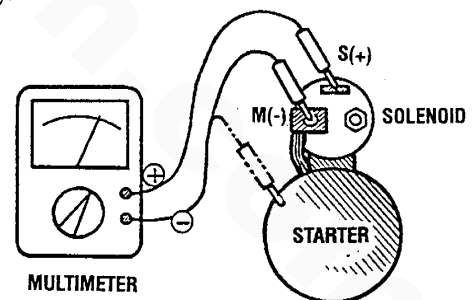

NOTE: Disconnect the wire from terminal M.

2. Connect a battery to the solenoid's terminal S for (+) and M for (-). Have a switch in the + lead and close it. The pinion drive should extend fully out.

CAUTION: Do not apply battery current for more than 10 seconds when testing the solenoid.

STARTER MOTOR

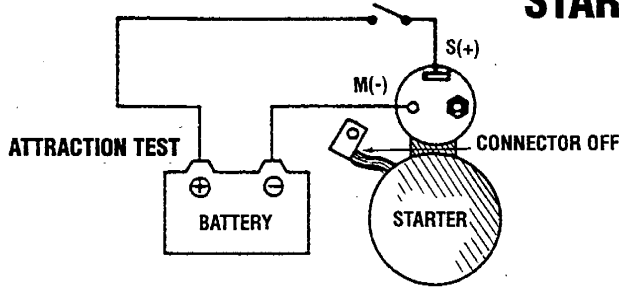

3. *Holding test.* With a battery connected to the solenoid terminal S (+) and to the starter body, manually pull out the pinion fully. The pinion must remain at that position even when released from holding with your hand.

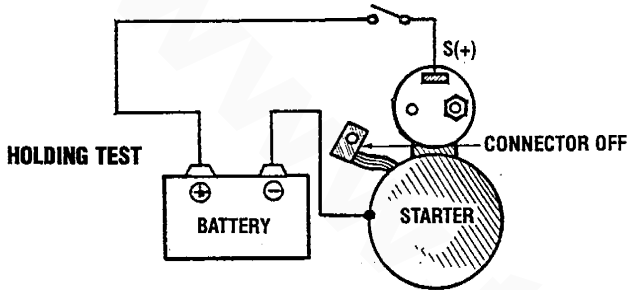

4. *Return test:* With a battery connected to the solenoid terminal M (-) and to the starter body, manually pull out the pinion fully. The pinion must return to its original position when released from holding by hand.

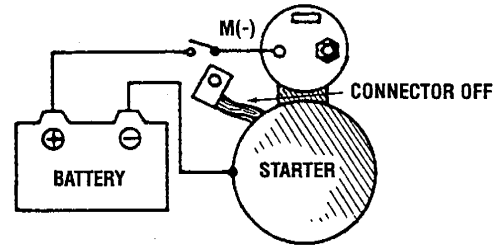

STARTER DISASSEMBLY

1. Disconnect the wire from the solenoid terminal M (-).
2. Loosen the two screws fastening the solenoid. Remove the solenoid assembly.
3. Remove the two long through bolts and two screws fastening the brush holder. Remove the rear bracket.
4. With the brushes pulled away from the armature, remove the yoke and brush holder assembly. Then pull the armature out.
5. Remove the cover, pry the snap ring out, and remove the washer.
6. Unscrew the bolts and remove the center bracket. At the same time, the washers for the pinion shaft end play adjustment will come off.

7. Pull out the reduction gear lever and lever spring from the front bracket.
8. On the pinion side, pry the snap ring out, and pull out the pinion and pinion shaft.
9. At each end of the armature, remove the ball bearing with a bearing puller. It is impossible to replace the ball bearing press-fitted in the front bracket. If that bearing has worn off, replace the front bracket assembly.

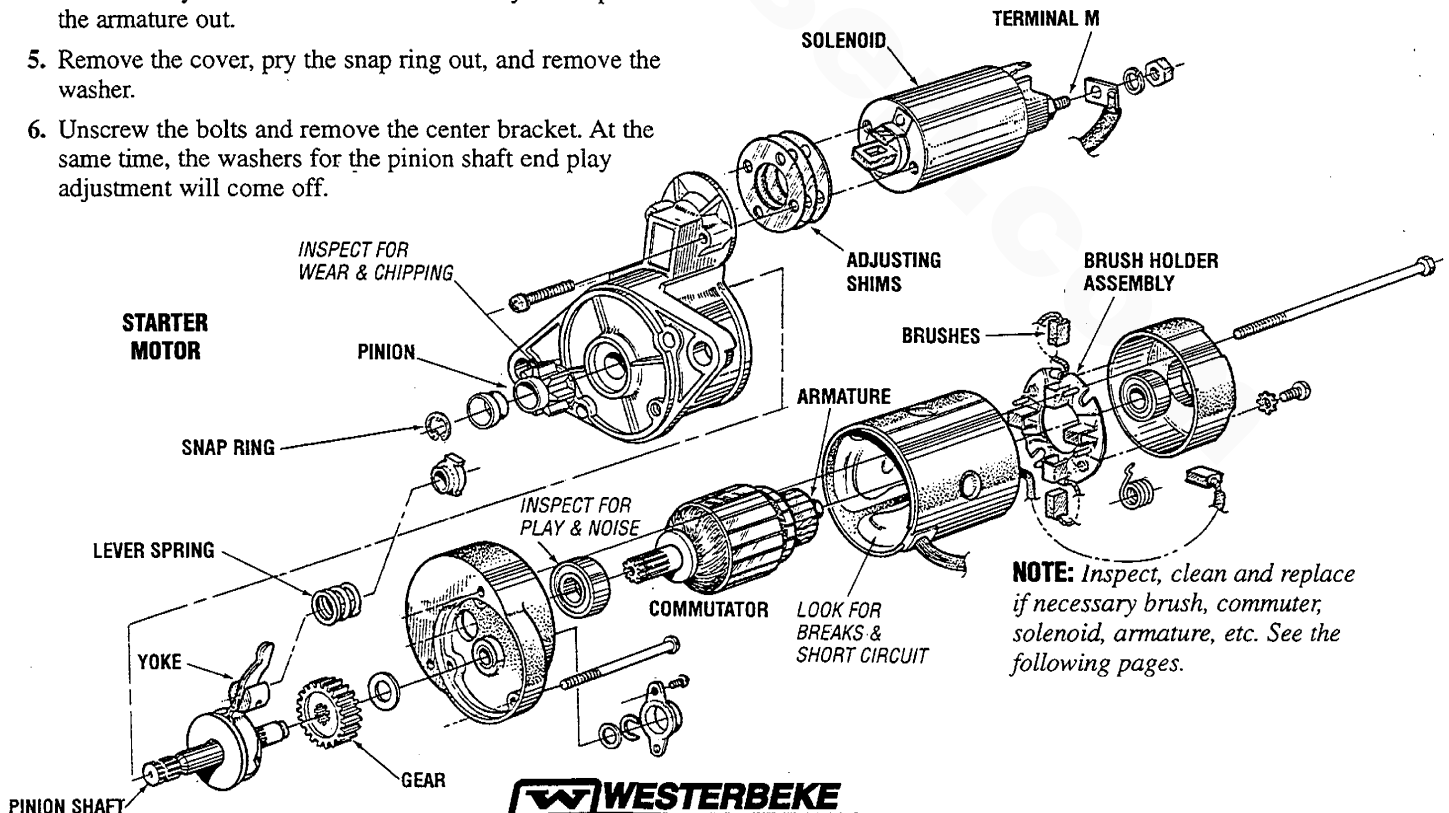

WESTERBEKE
Engines & Generators

STARTER MOTOR

STARTER INSPECTION

Solenoid

Inspect the solenoid for continuity between terminals S and M and between terminals S and body. No continuity should be found between S and M. Continuity should be found between S and the body and M and the body.

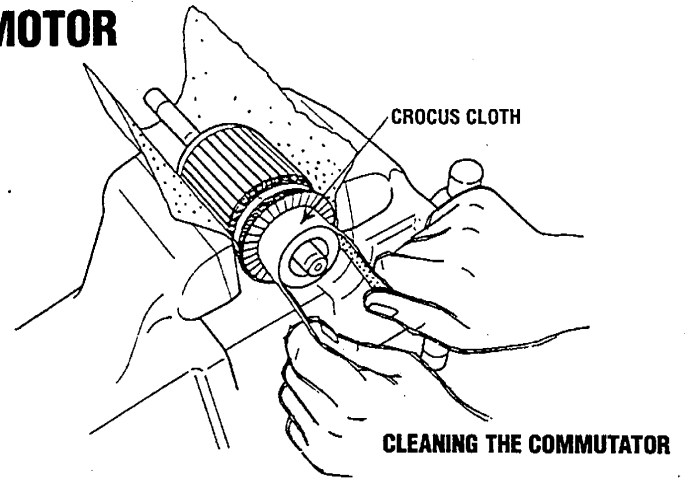
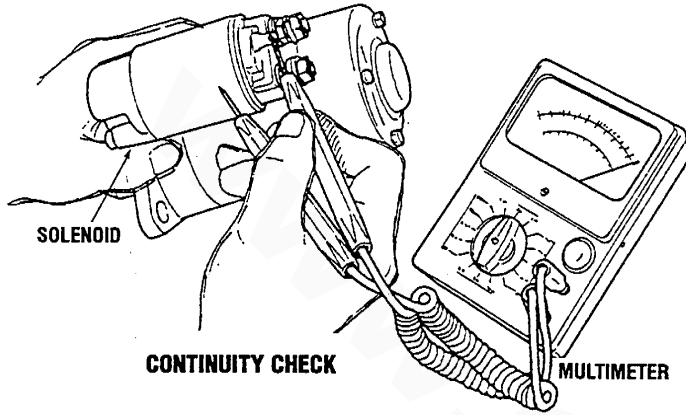

Brush and Brush Holder Inspection

1. Check the brushes. If worn out beyond the service limit, replace the brushes.

Brush Height
 Standard 17 mm (0.669 in)
 Limit 6 mm (0.236 in)

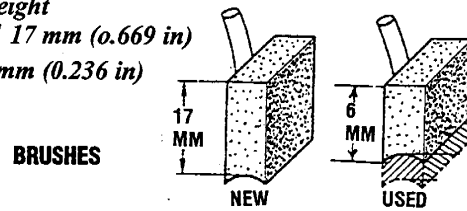

Inspecting The Armature

1. Check the armature with a growler tester. If it's short circuited, replace the armature. Also check for insulation between the commutator and its shaft. If poorly insulated, replace the armature.

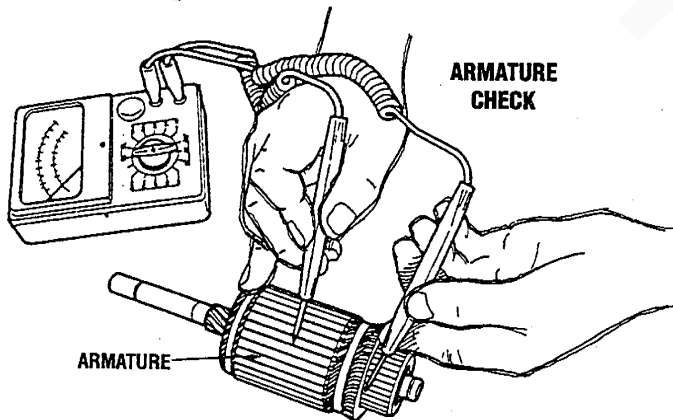

2. Check the brush spring tension. A weak or defective spring will cause excessive brush wear; replace the springs if suspect.

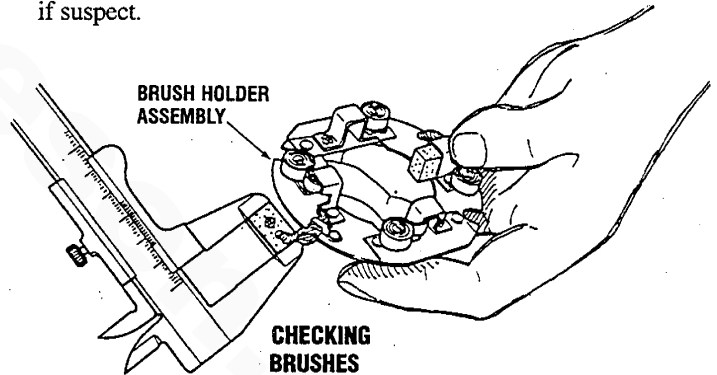

2. Measure the commutator O.D. and the depth of undercut. Repair or replace it if the service limit is exceeded. Also check the commutator outside surface for dirtiness and roughness. If rough, polish the commutator with fine crocus cloth.

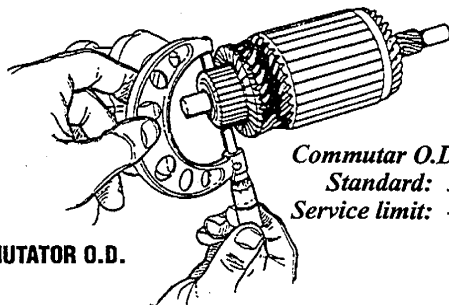

3. Check for insulation between the positive brush holder and holder base. If poorly insulated, replace the holder assembly. Also check the brush holders for proper staking.

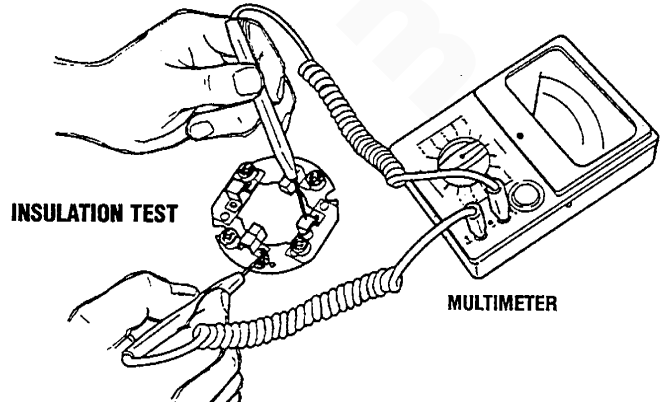

STARTER MOTOR

Field Coil Inspection

1. Check for insulation between one end (brush) of the coil and yoke.
2. Check for continuity between both ends (brushes) of the coil
3. Check the poles and coil for tightness.

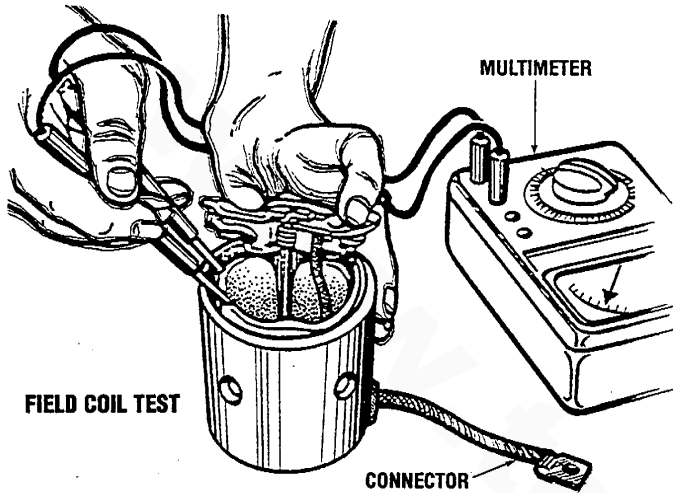

STARTER ADJUSTMENT AND REASSEMBLY

CAUTION: Before installing, thoroughly clean the starter flange and mounting surfaces, remove all oil, old paint, and rust. Starter performance largely depends on the quality of the wiring. Use wire of sufficient size and grade between the battery and starter and fully tighten to the terminal.

Reassemble the starter assembly in the reverse order of disassembly, making sure of the following:

1. *Pinion shaft end play adjustment.* Set the end play (thrust gap) to between 0.5 to 2 mm by inserting an adjusting washer between the center bracket and the reduction gear.
 - a. Fit the pinion shaft, reduction gear washer and snap ring to the center bracket.
 - b. Measure end play by moving the pinion shaft in the axial direction. If the end play exceeds 0.5 mm, increase the number of adjusting washers inserted.

2. *Greasing.* Whenever the starter has been overhauled, apply grease to the following parts:
 - a. Armature shaft gear and reduction gear.
 - b. All bearings.
 - c. Bearing shaft washers and snap rings.
 - d. Bearing sleeves.
 - e. Pinion.
 - f. Sliding portion of lever.

CAUTION: Never smear the starter fitting surface, terminals, brushes, or commutator with grease.

3. After reassembly, check by conducting a no-load test again.

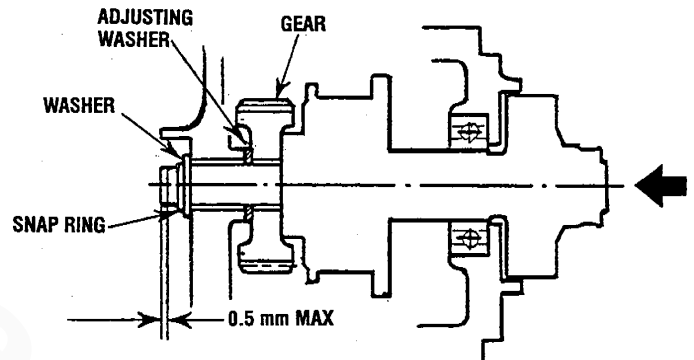

PINION SHAFT END PLAY

DC ELECTRICAL SYSTEM/ALTERNATOR

DESCRIPTION

The charging system consists of an alternator with a voltage regulator, an engine DC wiring harness, a mounted DC circuit breaker, and a battery with connecting cables. Because of the use of integrated circuits (IC's) the electronic voltage regulator is very compact and is mounted internally or on the back of the alternator.

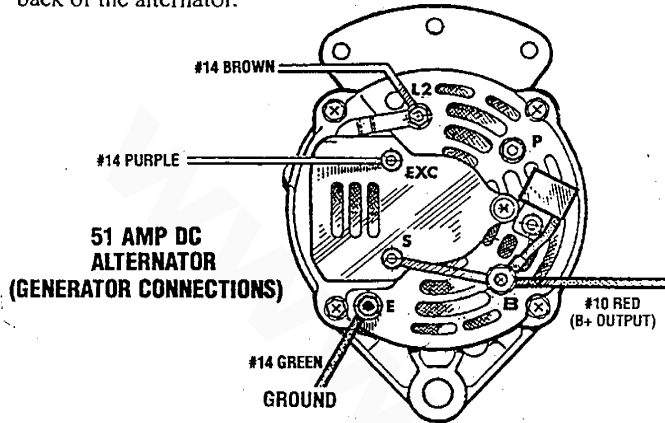

TROUBLESHOOTING

WARNING: A failed alternator can become very hot. Do not touch until the alternator has cooled down.

This troubleshooting section is to determine if a problem exists with the charging circuit or with the alternator. If it is determined that the alternator or voltage regulator is bad, it is best to have a qualified technician check it out.

The alternator charging circuit charges the starting battery and the service battery. An isolator with a diode, a solenoid, or a battery selector switch is usually mounted in the circuit to isolate the batteries, so the starting battery is not discharged along with the service battery. If the alternator is charging the starting battery but not the service battery, the problem is in the service battery charging circuit and not with the alternator.

Testing the Alternator

WARNING: Before starting the engine make certain that everyone is clear of moving parts! Keep away from sheaves and belts during test procedures.

NOTE: Multimeters and DC Circuits

DC and AC circuits are often mixed together in marine applications. Always disconnect shore power cords, isolate DC and AC converters and shutdown generators before performing DC testing. No AC tests should be made without proper knowledge of AC circuits.

1. Start the Engine
2. After a few minutes of running measure the starting battery voltage at the battery terminals using a multi-meter set on DC volts.
The voltage should be increasing toward 14 volts. If it is, your alternator is working.
3. Turn to step 5 on the next page.

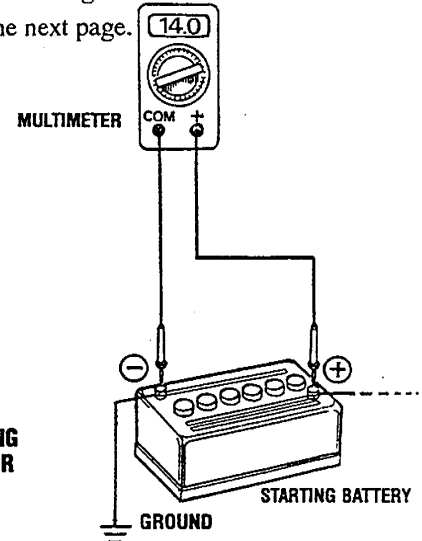

TESTING THE STARTING BATTERY-ALTERNATOR (ENGINE RUNNING)

4. If the starting battery voltage remains around 12 volts after the engine is started and run for a few minutes, a problem exists with the alternator or the charging circuit.
 - A. Turn off the engine. Inspect all wiring and connections. Insure that the battery terminals and the engine ground connections are tight and clean.

CAUTION: To avoid damage to the battery charging circuit, never shut off the engine battery switch when the engine is running!

- B. If a battery selector switch is in the charging circuit, insure that it is on the correct setting.
- C. Turn on the ignition switch, but do not start the engine.
- D. Check the battery voltage. If your battery is in good condition the reading should be 12 to 13 volts.

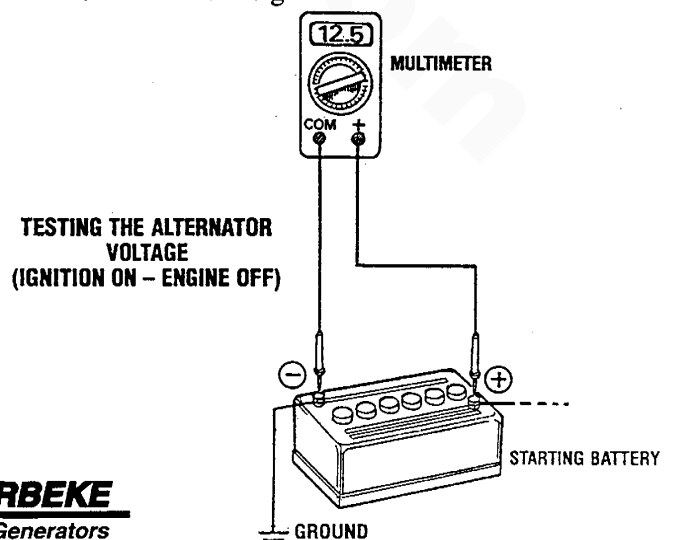

TESTING THE ALTERNATOR VOLTAGE (IGNITION ON - ENGINE OFF)



DC ELECTRICAL SYSTEM/ALTERNATOR

- E. Now check the voltage between the alternator output terminal (B+) and ground. If the circuit is good, the voltage at the alternator should be the same as the battery, or if an isolator is in the circuit the alternator voltage will be zero. If not, a problem exists in the circuit between the alternator and the battery. Check all connections - look for an opening in the charging circuit.

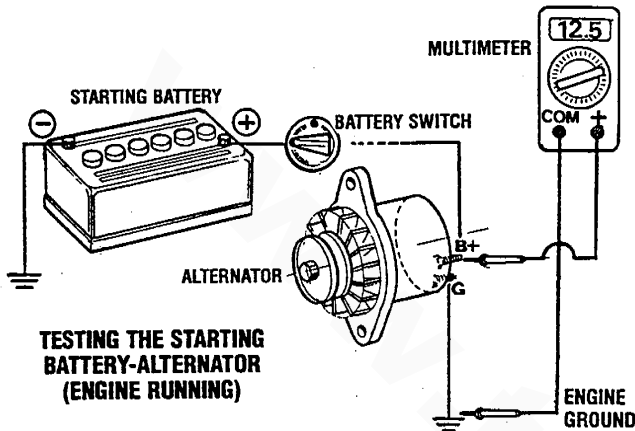

- F. Start the engine again. Check the voltage between the alternator output and ground.

The voltage reading for a properly operating alternator should be between 13.5 and 14.5 volts. If your alternator is over- or undercharging, have it repaired at a reliable service shop.

NOTE: Before removing the alternator for repair, use your voltmeter to ensure that 12 volts DC excitation is present at the EXC terminal if the previous test showed only battery voltage at the B output terminal.

If 12 volts is not present at the EXC terminal trace the wiring, look for breaks and poor connections.

Alternator is Working

5. Check the voltage of the service battery. This battery should have a voltage between 13 and 14 volts when the engine is running. If not, there is a problem in the service battery charging circuit. Trouble-shoot the service battery charging circuit by checking the wiring and connections, the solenoid, isolator, battery switch and the battery itself.

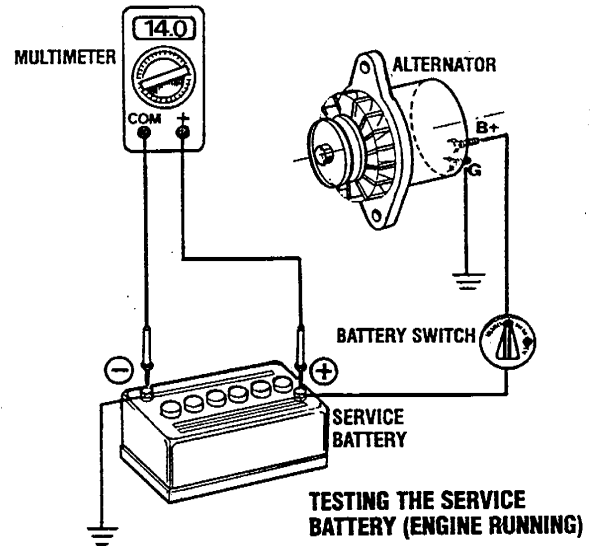

CAUTION: When performing tests on the alternator charging circuit do not use a high voltage tester (ie Megger). You can damage the alternator diodes.

ALTERNATOR INSPECTION

When rebuilding the engine, the alternator should be cleaned and inspected, the housing can be wiped off with a solvent and the alternator terminals cleaned with a wire brush, make certain the electrical studs are tight. Also clean the wiring connections that connect to the wiring harness. Turn the rotor pulley by hand, it should turn smoothly. Depending on when the alternator was last serviced, the brushes may need replacing. If the alternator is at all suspect, send it to a service shop for testing and overhaul.

(This page has been intentionally left blank.)

www.torresen.com



DC ELECTRICAL SYSTEM

WIRING SCHEMATIC #39144

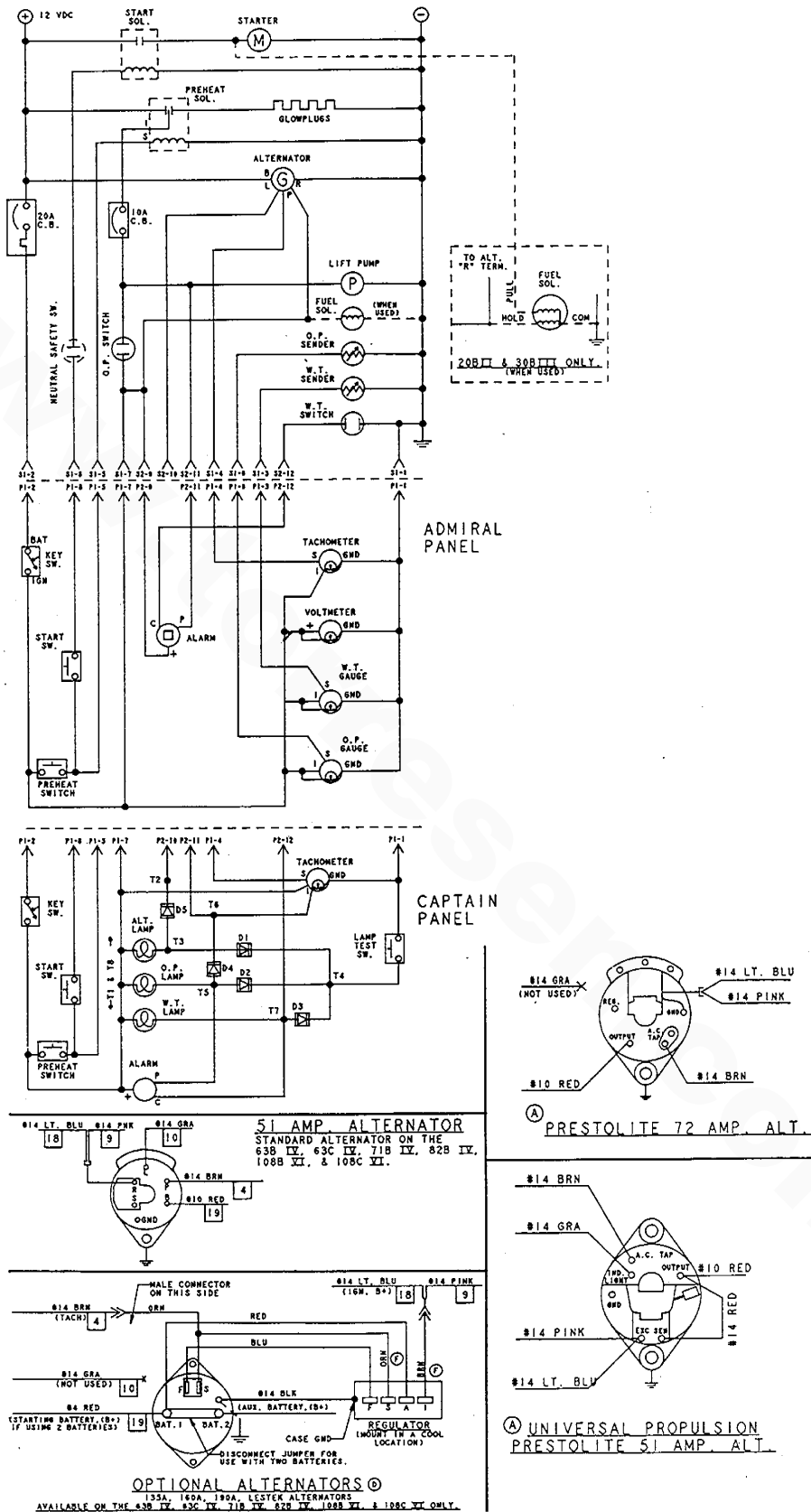

TRANSMISSIONS

WESTERBEKE uses a variety of marine transmissions made by well-known marine manufacturers such as *HURTH*, *ZF*, *BORG WARNER*, *PARAGON* and others. If you require transmission parts, repair work or an overhaul, we recommend contacting the transmission manufacturer directly for information on the locations of authorized service facilities. The addresses of two of these manufacturers are given below.

HURTH Marine Gear
ZF Industries
1018 Carolina Drive
West Chicago, IL 60185, U.S.A.

Tel: 874-634-3500
Fax: 874-913-1039

BORG WARNER Marine and Industrial Transmissions
200 Theodore Rice Blvd
New Bedford, MA 02745, U.S.A.

Tel: 508-979-4881 Customer Service
Tel: 508-979-4826 Technical Service

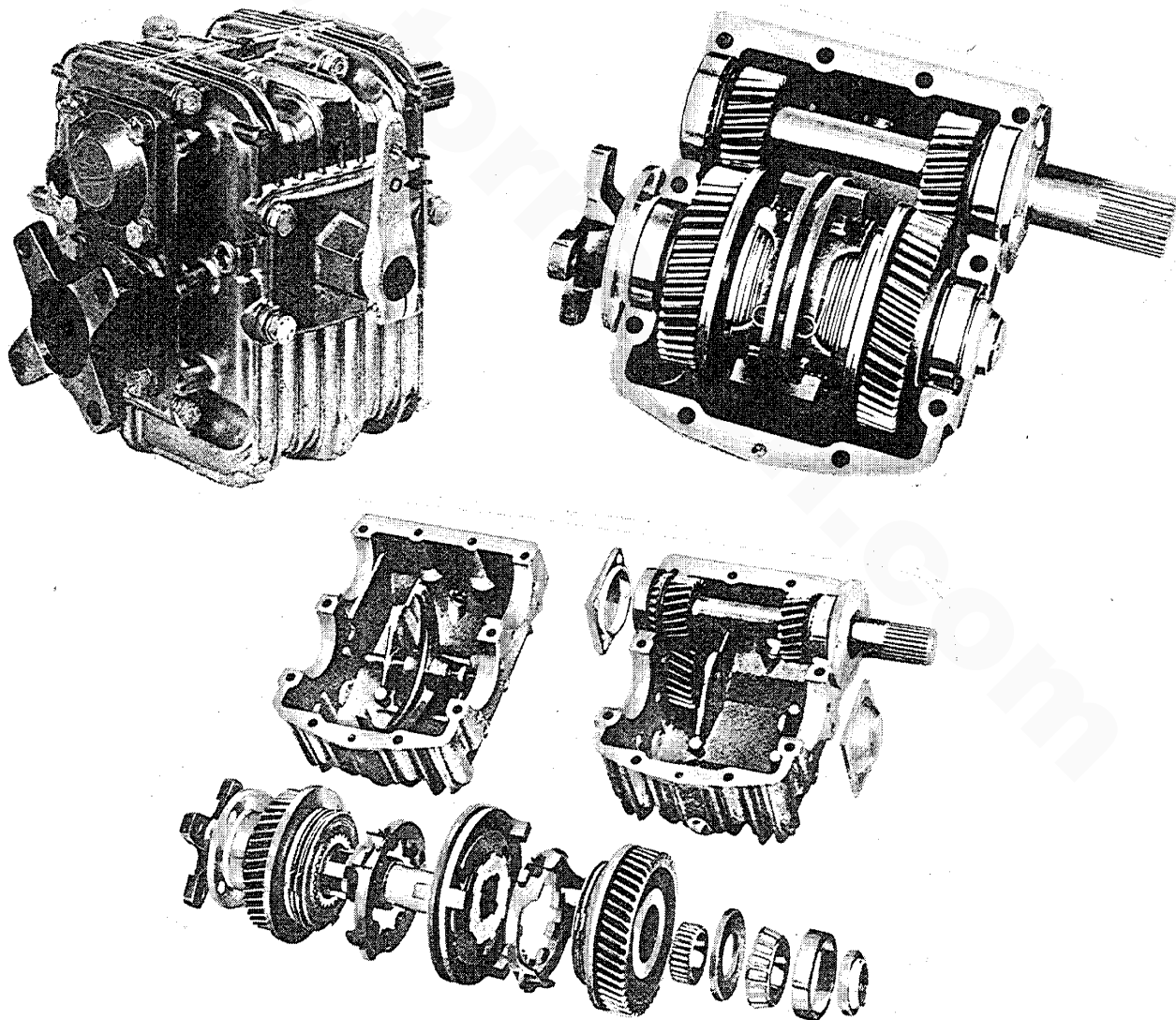

WESTERBEKE
Engines & Generators

SERVICE STANDARDS

DESCRIPTION	STANDARD VALUE	LIMIT
COMPRESSION PRESSURE	30 kg/cm ² (426 lb/in ²)/200 rpm	27kg/cm ² (384 lb/in ²)/200 rpm
INTER-CYLINDER DIFFERENCE (max)	42.7 psi (3.0 kg/cm ²)	
INJECTION ORDER	1-3-4-2	
INJECTION TIMING	0° TDC	
CYLINDER HEAD		
Bottom surface distortion		1.0 mm (0.004 in)
Manifold contact surface distortion		0.20 mm (0.008 in)
Valve seat angles (IN and EX)	45°	
Valve seat width (IN and EX)	1.7-2.3 mm (0.067-0.091 in)	
Valve seat recession (IN and EX)	0.75-1.05 mm (0.030-0.041 in)	
Valve seat contact	1.7-2.3 mm (0.067-0.091 in)	
Combustion chamber insert recession		Receded amount: 0.04 mm (0.0016 in) Projection amount: 0.05 mm (0.0024 in)
Cylinder head bolt length	112.7-113.3 mm (4.437-4.460 in)	114.5 mm (4.508 in)
VALVE CLEARANCE		
Intake	0.20-0.30 mm (0.008-0.012 in)	
Exhaust	0.30-0.40 mm (0.012-0.016 in)	
VALVE TIMING		
Intake: open	BTDC 13°	
Intake: closed	ABDC 39°	
Exhaust: open	BBDC 60°	
Exhaust: closed	ATDC 8°	
VALVE		
Stem O.D. Intake	7.970-7.985 mm (0.3138-0.3144 in)	
Exhaust	7.965-7.980 mm (0.3136-0.3142 in)	
Stem to guide clearance	0.051-0.075 mm (0.002-0.003 in)	0.10 mm (0.004 in)
Valve face angle (IN and EX)	45°	
Valve head thickness (margin width)	1.5 mm (0.059 in)	1.0 mm (0.039 in)
Valve recession (IN and EX)	0.75-1.05 mm (0.030-0.041 in)	1.55-2.55 mm (0.061-0.100 in)
VALVE SPRING		
Free length		44.8 mm (1.764 in)
Angle Limit		1.58 mm (0.062 in)
CYLINDER BLOCK		
Cylinder bore	86.00 mm (3.39 in)	86.17 mm (3.92 in)
Difference between cylinder bores	0.022 mm (0.0009 in)	
Cylinder bore oversize finish tolerance	0.25 mm (0.010 in); 0.50 mm (0.020 in)	
Taper of cylinder		
Top surface distortion		0.10 mm (0.0040 in)

(continued)



DESCRIPTION	STANDARD VALUE	LIMIT
PISTON		
O.D. (skirt end)	85.95–85.98 mm (3.384–2.385 in)	
Piston to cylinder clearance	0.07–0.08 mm (0.002–0.003 in)	0.15 mm (0.006 in)
Oversize piston rings	0.25 mm (0.010 in); 0.50 mm (0.020 in)	
PISTON PIN		
Type	Full Floating	
O.D.	25.0–25.01 mm (0.9842–0.9846 in)	
Piston to pin clearance	0.003–0.006 mm (0.0001–0.0002 in)	
Pin to connecting rod clearance	0.012–0.03 mm (0.0005–0.001 in)	
PISTON RINGS		
Number of compression rings	Two	
Number of oil rings	One	
Ring side clearance		0.2 mm (0.008 in)
Compression ring No. 1	0.03 – 0.06 mm (0.001–0.002 in)	
Compression ring No. 2	0.03 – 0.06 mm (0.001–0.002 in)	
Oil ring	0.03 – 0.06 mm (0.001–0.002 in)	
Ring end gap	0.3–0.5 mm (0.012–0.020 in)	1.0 mm (0.039 in)
CONNECTING ROD		
Bending or torsion		0.16 mm (0.006 in) per 100 mm (3.94 in)
Bushing inner diameter	25.01–25.03 mm (0.9846–0.9854 in)	
End play	0.11–0.26 mm (0.0043–0.0102 in)	0.35 mm (0.014 in)
Sideplay clearance		0.05 mm (0.002 in)
CONNECTING ROD BEARING		
Standard Type	Kelmet metal	
Oil clearance	0.03–0.06 mm (0.0012–0.0024 in)	0.08 mm (0.0031 in)
Undersize	0.25 mm (0.010 in); 0.50 mm (0.020 in); 0.75 mm (0.030 in)	
CRANKSHAFT		
Deflection		0.05 mm (0.002 in)
End play	0.04–0.28 mm (0.0016–0.0111 in)	0.03 mm (0.0118 in)
Thrust bearing width		
Undersize	2.18–2.23 mm (0.0858–0.0878 in)	
Standard	2.00–2.05 mm (0.0787–0.0807 in)	
Main journal O.D.	59.94–59.96 mm (2.360–2.361 in)	0.05 mm (0.0020 in)
Pin O.D.	50.94–50.96 mm (2.006–2.007 in)	
Rear housing oil seal sliding surface	88.95–90.00 mm (3.541–3.543 in)	
Journal grinding limit	0.75 mm (0.0295 in)	
Undersize finish tolerance	0.25 mm (0.010 in); 0.50 mm (0.020 in); 0.75 mm (0.0295 in)	

(continued)



SERVICE STANDARDS

DESCRIPTION	STANDARD VALUE	LIMIT
MAIN BEARING		
Standard type	Kelmet metal	
Oil clearance	0.031–0.049 mm (0.0012–0.0019 in)	0.08 mm (0.0031 in)
Undersize	0.25 mm (0.010 in); 0.50 mm (0.020 in)	
CAMSHAFT	0.75 mm (0.030 in)	
Front bearing	Lead bronze alloy	
Oil clearance	0.025 –0.066 mm (0.0098–0.0260 in)	
Cam lobe height: Intake	44.31 mm (1.744 in)	43.90 mm (1.728 in)
Exhaust	45.30 mm (1.783 in)	44.90 mm (1.768 in)
End play	0.02–0.15 mm (0.00079–0.00591 in)	0.2 mm (0.0079 in)
Journal elliptical		0.05 mm (0.002 in)
Journal diameters	31.96–31.98 mm (1.258–1.259 in)	31.86 mm (1.254 in)
Deflection		0.10 mm (0.0040 in)
TAPPET		
O.D.	34.96–34.98 mm (1.3763 –1.3771 in)	
Hole	34.99–35.02 mm (1.3776–1.3787 in)	
Tappet to cylinder block clearance	0.02–0.06 mm (0.0008–0.0024 in)	0.10 mm (0.0040 in)
TIMING BELT DEFLECTION	10.8–12.9 mm (0.43–0.51 in)/10 kg (22 lb)	
ALTERNATOR DRIVE BELT DEFLECTION		
New	11–12 mm (0.44–0.47 in)/10 kg (22 lb)	
Used	12–14 mm (0.47–0.55 in)/10 kg (22 lb)	

SERVICE STANDARDS

LUBRICATION SYSTEM

Lubricating System		Force-fed type
Oil pump	Type	Crescent inner gear
	Oil pressure control valve opening pressure	8.0 kg/cm ² (114 lb/in ²)
Oil filter	Type	Full-flow type, spin-on paper element
	Oil filter relief valve opening pressure	1.0 kg/cm ² (14 lb/in ²)
	Outer gear tooth tip to crescent clearance limit	0.35 mm (0.013 in)
	Inner gear tooth tip to crescent clearance limit	0.35 mm (0.013 in)
	Side clearance limit	0.15 mm (0.006 in)
	Outer gear to pump body clearance limit	0.20 mm (0.008 in)
Oil bypass filter	Type	Full-flow type, paper element
Oil cooler	Type	Water cooled
Oil filter body	Oil pressure control valve opening pressure	4.5 kg/cm ² (64 lb/in ²)
	Oil filter relief valve opening pressure	1.0 kg/cm ² (14 lb/in ²)
	Oil cooler relief valve opening pressure	2.0 kg/cm ² (28 lb/in ²)
Oil alarm switch activation pressure		0.35–0.70 kg/cm ² (5–10 lb/in ²)
Total oil capacity		6.4 liters (6.76 U.S. quarts, 5.63 Imp. quarts)
Oil pan capacity		5.0 liters (5.28 U.S. quarts, 4.40 Imp. quarts)
Oil filter capacity		0.4 liters (0.42 U.S. quarts, 0.35 Imp. quarts)
Oil bypass filter capacity		0.4 liters (0.42 U.S. quarts, 0.35 Imp. quarts)
Engine oil		API Specification CF or CG-4, SAE 30, 10W-30, 15W-40

METRIC CONVERSIONS

INCHES TO MILLIMETERS				MILLIMETERS TO INCHES			
Inches	mm	Inches	mm	mm	Inches	mm	Inches
1	25.40	15	381.00	1	0.0394	15	0.5906
2	50.80	20	508.00	2	0.0787	20	0.7874
3	76.20	25	635.00	3	0.1181	25	0.9843
4	101.60	30	762.00	4	0.1575	30	1.1811
5	127.00	35	889.00	5	0.1969	35	1.3780
10	254.00	40	1016.00	10	0.3937	40	1.5748

10 MILLIMETERS = 1 CENTIMETER, 100 CENTIMETERS = 1 METER = 39.37 INCHES (3.3 FEET)

INCHES TO METERS				METERS TO INCHES			
Inches	Meters	Inches	Meters	Meters	Inches	Meters	Inches
1	0.0254	7	0.1778	0.1	3.937	0.7	27.559
2	0.0508	8	0.2032	0.2	7.874	0.8	31.496
3	0.0762	9	0.2286	0.3	11.811	0.9	35.433
4	0.1016	10	0.2540	0.4	15.748	1.0	39.370
5	0.1270	11	0.2794	0.5	19.685	1.1	43.307
6	0.1524	12	0.3048	0.6	23.622	1.2	47.244

TO CONVERT METERS TO CENTIMETERS, MOVE DECIMAL POINT TWO PLACES TO THE RIGHT

YARDS TO METERS				METERS TO YARDS			
Yards	Meters	Yards	Meters	Meters	Yards	Meters	Yards
1	0.91440	6	5.48640	1	1.09361	6	6.56168
2	1.82880	7	6.40080	2	2.18723	7	7.65529
3	2.74320	8	7.31520	3	3.28084	8	8.74891
4	3.65760	9	8.22960	4	4.37445	9	9.84252
5	4.57200	10	9.14400	5	5.46807	10	10.93614

MOVE DECIMAL POINT FOR HIGHER VALUES — e.g. 6,000 METERS = 6,561.68 YARDS

POUNDS TO KILOGRAMS				KILOGRAMS TO POUNDS			
lb	kg	lb	kg	kg	lb	kg	lb
1	0.454	6	2.722	1	2.205	6	13.228
2	0.907	7	3.175	2	4.409	7	15.432
3	1.361	8	3.629	3	6.614	8	17.637
4	1.814	9	4.082	4	8.818	9	19.842
5	2.268	10	4.536	5	11.023	10	22.046

GALLONS TO LITERS				LITERS TO GALLONS			
Gallons	Liters	Gallons	Liters	Liters	Gallons	Liters	Gallons
1	3.79	10	37.86	1	0.26	60	15.66
2	7.57	20	75.71	2	0.53	90	23.77
3	11.36	30	113.57	5	1.32	120	31.32
4	15.14	40	151.42	10	2.64	150	39.62
5	18.93	50	189.28	20	5.28	180	47.54

PINTS TO LITERS				LITERS TO PINTS			
Pints	Liters	Pints	Liters	Liters	Pints	Liters	Pints
1	0.47	6	2.84	1	2.11	6	12.68
2	0.95	7	3.31	2	4.23	7	14.79
3	1.42	8	3.79	3	6.34	8	16.91
4	1.89	9	4.26	4	8.45	9	19.02
5	2.37	10	4.73	5	10.57	10	21.13

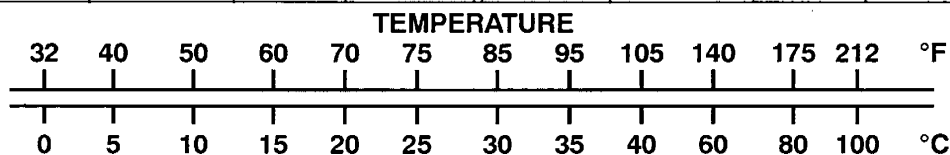

55A FOUR TORQUES

	kg-m	ft-lb
Cylinder head NOTE: The cylinder head bolts are not retorqued. They are torqued only at the original engine assembly and during an engine overhaul.	30	21.7
Cylinder head cover	0.7-1.0	5-7
Connecting rod bearing cap	7.0-7.5	51-54
Main bearing cap	8.4-9.0	61-65
Flywheel	18-19	130-137
Thrust plate	1.9-2.6	14-19
Crankshaft pulley	2.3-3.3	17-24
Camshaft cap	2.0-2.7	15-20
Camshaft pulley	5.6-6.6	41-48
Timing belt pulley	16-17	116-123
Idler pulley	3.2-4.7	23-34
Timing belt tensioner	3.2-4.7	23-34
Timing belt covers	0.7-1.0	5-7
Seal plate	0.8-1.2	6-9
Back plate	1.6-2.3	12-17
Rear oil seal housing	0.7-1.0	5-7
Oil pump assembly M10 bolt	3.2-4.7	23-34
M8 bolt	1.6-2.3	12-17
Oil cooler assembly M10 bolt	3.2-4.7	23-34
M6 bolt	0.7-1.0	5-7
Oil filter	Tighten firmly by hand	
Block oil jets	1.2-1.8	9-13
Oil strainer pick-up	0.7-1.0	5-7
Oil pan	0.7-1.0	5-7
Oil drain hose	2.7-3.3	20-24
Oil pressure sender	1.2-1.8	9-13
Oil pressure switch	1.2-1.8	9-13
Fuel injection pump	3.2-4.7	23-34
Fuel injection pump pulley	6.0-7.0	43-52
Fuel injectors	6.0-7.0	43-51
Fuel injector H/P line	1.8-2.3	13-17
Glow plugs	1.5-2.0	11-15
Coolant Pump	3.2-4.7	23-34
Thermostat housing	1.6-2.3	12-17
Coolant temperature sender	1.2-1.8	9-13
Coolant temperature switch	1.2-1.8	9-13
Alternator bracket	3.8-5.3	27-38
Intake/exhaust manifold	2.2-2.7	16-20
Engine mounts	3.2-4.7	23-34



STANDARD HARDWARE TORQUES

NOTE: Unless stated otherwise for a specific assembly, use the following torque values when tightening standard hardware.

Grade 4	Pitch	lb-ft	kg-m	Grade 7T, 8T and 8.8	Pitch	lb-ft	kg-m
6mm bolt head/nut	1	2.9-5.1	0.4-0.7	6mm bolt head/nut	1	5.8-8.7	0.8-1.2
8mm bolt head/nut	1.25	7.2-11.6	1.0-1.6	8mm bolt head/nut	1.25	14.5-21.7	2.0-3.0
10mm bolt head/nut	1.25	13.7-22.4	1.9-3.1	10mm bolt head/nut	1.25	28.9-39.8	4.0-5.5
10mm bolt head/nut	1.5	13.0-21.7	1.8-3.0	10mm bolt head/nut	1.5	26.8-37.6	3.7-5.2
12mm bolt head/nut	1.25 (ISO)	25.3-39.8	3.5-5.5	12mm bolt head/nut	1.25 (ISO)	54.2-75.9	7.5-10.5
12mm bolt head/nut	1.5	25.3-39.8	3.5-5.5	12mm bolt head/nut	1.5	50.6-65.1	7.0-9.0
12mm bolt head/nut	1.75	21.7-36.2	3.0-5.0	12mm bolt head/nut	1.75	43.4-61.5	6.0-8.5
13mm bolt head/nut	1.5	32.5-50.6	4.5-7.0	13mm bolt head/nut	1.5	57.9-86.8	8.0-12.0
14mm bolt head/nut	1.5	36.2-57.9	5.0-8.0	14mm bolt head/nut	1.5	72.3-108.5	10.0-15.0
14mm bolt head/nut	2	34.0-55.7	4.7-7.7	14mm bolt head/nut	2	68.7-101.3	9.5-14.0
16mm bolt head/nut	1.5	54.2-79.6	7.5-11.0	16mm bolt head/nut	1.5	108.5-166.4	15.0-23.0
16mm bolt head/nut	2	51.4-76.7	7.1-10.6	16mm bolt head/nut	2	101.3-159.1	14.0-22.0
Grade 6T				Grade 5 Cap Screw			
6mm bolt head/nut	1	4.3-6.5	0.6-0.9	1/4 UNC		9-11	1.2-1.5
8mm bolt head/nut	1.25	10.8-15.9	1.5-2.2	1/4 UNF		11-13	1.5-1.8
10mm bolt head/nut	1.25	21.7-32.5	3.0-4.5	5/16 UNC		18-20	2.5-2.8
10mm bolt head/nut	1.5	19.5-30.4	2.7-4.2	5/16 UNF		21-23	2.9-3.2
12mm bolt head/nut	1.25 (ISO)	36.2-57.9	5.0-8.0	3/8 UNC		28-33	3.7-4.6
12mm bolt head/nut	1.5	36.2-50.6	5.0-7.0	3/8 UNF		30-35	4.1-4.8
12mm bolt head/nut	1.75	34.7-49.2	4.8-6.8	7/16 UNC		44-49	6.1-6.8
				7/16 UNF		50-55	6.9-7.6
				1/2 UNC		68-73	9.4-10.1
				1/2 UNF		73-80	10.1-11.1

GENERAL SCREWS

BOLT DIA.	BOLT HEAD MARK		
	4	7	10
M6	0.3 - 0.5	0.8 - 1.0	1.0 - 1.3
M8	1.0 - 1.3	1.5 - 2.2	2.5 - 3.5
M10	1.8 - 2.5	3.0 - 4.2	5.0 - 7.0
M12	3.0 - 4.2	5.5 - 7.5	9.5 - 12.0
M14	5.0 - 7.0	8.0 - 11.0	16.0 - 19.0

SEALANTS

PARTS REQUIRING SEALANT	SURFACES REQUIRING SEALANT (where to mount sealant coated parts)	SEALANT
Taper screw 1/2 "	Thread portion (Gear case)	Liquid Teflon
Taper screw 1/4 "	Thread portion (Cylinder block right side, pump cover)	Liquid Teflon
Taper screw 1/8 "	Thread portion (Cylinder head rear surface)	Liquid Teflon
Water drain plug	Thread portion (Cylinder block right side, rear middle portion)	Liquid Teflon
Oil pressure switch	Thread portion (Cylinder block right side surface)	Liquid Teflon
Side seal	Periphery (Main bearing caps No. 1 and No. 5)	Permatex #6B
Bearing cap No. 1	Contact surface with cylinder block	Permatex #6B



INDEX

Adjusting Discs		Fuel Injection Pump	
Removal	14	Removal	12
Inspection	20	Reassembly	35
Reassembly	27	Fuel Injection Pump Pulley	
Adjustments, Engine	42	Removal	13
Alternator	39, 67	Inspection	25
Back Plate	32	Reassembly	37
Bellhousing	40	Fuel Injection Pump Timing Adjustment	50
Camshaft		Fuel Injectors Testing	47
Removal	14	Glow Plugs	34, 51
Inspection	20	Heat Exchanger	40, 60
Reassembly	34	Idle Speed Adjustment	49
Camshaft Pulley		Idler Pulley Bracket	36
Removal	14	Injection Nozzles	34
Reassembly	36	Injection Pump Pulley	
Combustion Chamber Inserts	15	Removal	13
Compression Test	46	Inspection	25
Connecting Rods		Reassembly	37
Removal	12	Injection Pump Timing Adjustment	50
Inspection	23	Inspection and Repair, Engine	16
Reassembly	27	Intake/Exhaust Manifold	38, 61
Connecting Rod Bearings	24	Lubrication System	52
Connecting Rod Bushings	23	Main Bearings	24
Coolant Pump	35, 58	Metric Conversions	77
Crankshaft		Mounts, Engine	40
Removal	12	Oil Cooler	39, 54
Inspection	23	Oil Dipstick Tube	35
Reassembly	28	Oil Filter	39
Crankshaft Pulley	38	Oil Filter, Remote (Optional)	57
Cylinder Block	21	Oil Jets	55
Cylinder Head		Oil Pan	31, 52
Removal	14	Oil Pressure Sender	55
Inspection	16	Oil Pressure Switch	35, 55
Reassembly	33	Oil Pressure Test	46, 56
Cylinder Head Bolts	14	Oil Pump	31, 53
Cylinder Head Cover	40	Oil Strainer	31
Cylinder Head Gasket	14	Parts Identification	5
Damper Plate	40	Parts Ordering	2
Disassembly, Engine	11	Piston Rings	22
Drive Belt Adjustment	42	Pistons	22, 27
Engine Adjustments	42	Product Software	2
Engine Disassembly	11	Raw Water Pump	40, 59
Engine Mounts	40	Rear Cover Assembly	30
Flywheel	32	Reassembly, Engine	26
Fuel Filter	40	Seal Plate	36
Fuel Injection Lines	35	Service Standards	73
Fuel Injection Nozzles	34	Specifications	4

(continued)



INDEX

Starter Motor	63
Tachometer	62
Tappets	
Removal	14
Inspection	20
Reassembly	27
Testing for Overhaul	6
Thermostat	36
Timing Belt	
Removal	13
Inspection	24
Reassembly	37
Timing Belt Adjustment	43
Timing Belt Camshaft	25
Timing Belt Covers	25
Timing Belt Pulley	
Removal	14
Reassembly	32
Timing Belt Tensioner	
Removal	13
Inspection	25
Reassembly	37
Torques, 55A FOUR	78
Torques, Standard Hardware	79
Torsional Damper	38
Transmission	
Removal	11
Reassembly	41
Transmissions	72
Troubleshooting, Engine	7
Valves	
Removal	15
Inspection	18
Reassembly	26
Valve Clearance Adjustment	42
Valve Guides	19
Valve Seals	15
Valve Seats	17
Valve Springs	20
Wiring Diagram	70
Wiring Schematic	71

www.torresen.com

