



# **SERVICE MANUAL**

## **4-CYLINDER MARINE DIESEL ENGINES & GENERATORS**

### **MARINE DIESEL ENGINES**

38B FOUR	W-33	42B FOUR
W-27	W-33A	
RD80		
W-27A		

### **MARINE DIESEL GENERATORS**

WMD 11.0-60Hz	WMD 12.5-60Hz	12.5 BTDA
WMD 8.3-50Hz	WMD 9.4-50Hz	9.4 BTDA
11.0 BTDA	12.5 BTDA	
8.3 BTDA	9.4 BTDA	

**PUBLICATION NO. 43440**  
2nd Edition / April 1998



WESTERBEKE CORPORATION • MYLES STANDISH INDUSTRIAL PARK  
150 JOHN HANCOCK ROAD, TAUNTON, MA 02780-7319 U.S.A.

**CALIFORNIA  
PROPOSITION 65 WARNING**

Diesel engine exhaust and some of its constituents are known to the State of California to cause cancer, birth defects, and other reproductive harm.

 **WARNING**

*Exhaust gasses contain Carbon Monoxide, an odorless and colorless gas. Carbon Monoxide is poisonous and can cause unconsciousness and death. Symptoms of Carbon Monoxide exposure can include:*

- *Dizziness*
- *Nausea*
- *Headache*
- *Weakness and Sleepiness*
- *Throbbing in Temples*
- *Muscular Twitching*
- *Vomiting*
- *Inability to Think Coherently*

***IF YOU OR ANYONE ELSE EXPERIENCE ANY OF THESE SYMPTOMS, GET OUT INTO THE FRESH AIR IMMEDIATELY. If symptoms persist, seek medical attention. Shut down the unit and do not restart until it has been inspected and repaired.***

## SAFETY INSTRUCTIONS

### INTRODUCTION

*Read these safety instructions carefully. Most accidents are caused by failure to follow fundamental rules and precautions. Know when dangerous conditions exist and take the necessary precautions to protect yourself, your personnel, and your machinery.*

*The following safety instructions are in compliance with the American Boat and Yacht Council (ABYC) standards.*

### PREVENT ELECTRIC SHOCK

**⚠ WARNING:** *Do not touch AC electrical connections while engine is running, or when connected to shore power. Lethal voltage is present at these connections!*

- Do not operate this machinery without electrical enclosures and covers in place.
- Shut off electrical power before accessing electrical equipment.
- Use insulated mats whenever working on electrical equipment.
- Make sure your clothing and skin are dry, not damp (particularly shoes) when handling electrical equipment.
- Remove wristwatch and all jewelry when working on electrical equipment.
- Do not connect utility shore power to vessel's AC circuits, except through a ship-to-shore double throw transfer switch. Damage to vessel's AC generator may result if this procedure is not followed.
- Electrical shock results from handling a charged capacitor. Discharge capacitor by shorting terminals together.

### PREVENT BURNS — HOT ENGINE

**⚠ WARNING:** *Do not touch hot engine parts or exhaust system components. A running engine gets very hot!*

- Always check the engine coolant level at the coolant recovery tank.

**⚠ WARNING:** *Steam can cause injury or death!*

- In case of an engine overheat, allow the engine to cool before touching the engine or checking the coolant.

### PREVENT BURNS — FIRE

**⚠ WARNING:** *Fire can cause injury or death!*

- Prevent flash fires. Do not smoke or permit flames or sparks to occur near the carburetor, fuel line, filter, fuel pump, or other potential sources of spilled fuel or fuel vapors. Use a suitable container to catch all fuel when removing the fuel line, carburetor, or fuel filters.
- Do not operate with a Coast Guard Approved flame arrester removed. Backfire can cause severe injury or death.
- Do not operate with the air cleaner/silencer removed. Backfire can cause severe injury or death.
- Do not smoke or permit flames or sparks to occur near the fuel system. Keep the compartment and the engine/generator clean and free of debris to minimize the chances of fire. Wipe up all spilled fuel and engine oil.
- Be aware — diesel fuel will burn.

### PREVENT BURNS — EXPLOSION

**⚠ WARNING:** *Explosions from fuel vapors can cause injury or death!*

- Follow re-fueling safety instructions. Keep the vessel's hatches closed when fueling. Open and ventilate cabin after fueling. Check below for fumes/vapor before running the blower. Run the blower for four minutes before starting your engine.
- All fuel vapors are highly explosive. Use extreme care when handling and storing fuels. Store fuel in a well-ventilated area away from spark-producing equipment and out of the reach of children.
- Do not fill the fuel tank(s) while the engine is running.
- Shut off the fuel service valve at the engine when servicing the fuel system. Take care in catching any fuel that might spill. DO NOT allow any smoking, open flames, or other sources of fire near the fuel system or engine when servicing. Ensure proper ventilation exists when servicing the fuel system.
- Do not alter or modify the fuel system.
- Be sure all fuel supplies have a positive shutoff valve.
- Be certain fuel line fittings are adequately tightened and free of leaks.
- Make sure a fire extinguisher is installed nearby and is properly maintained. Be familiar with its proper use. Extinguishers rated ABC by the NFPA are appropriate for all applications encountered in this environment.



## SAFETY INSTRUCTIONS

### ACCIDENTAL STARTING

**⚠ WARNING: Accidental starting can cause injury or death!**

- Disconnect the battery cables before servicing the engine/generator. Remove the negative lead first and reconnect it last.
- Make certain all personnel are clear of the engine before starting.
- Make certain all covers, guards, and hatches are re-installed before starting the engine.

### BATTERY EXPLOSION

**⚠ WARNING: Battery explosion can cause injury or death!**

- Do not smoke or allow an open flame near the battery being serviced. Lead acid batteries emit hydrogen, a highly explosive gas, which can be ignited by electrical arcing or by lit tobacco products. Shut off all electrical equipment in the vicinity to prevent electrical arcing during servicing.
- Never connect the negative (-) battery cable to the positive (+) connection terminal of the starter solenoid. Do not test the battery condition by shorting the terminals together. Sparks could ignite battery gases or fuel vapors. Ventilate any compartment containing batteries to prevent accumulation of explosive gases. To avoid sparks, do not disturb the battery charger connections while the battery is being charged.
- Avoid contacting the terminals with tools, etc., to prevent burns or sparks that could cause an explosion. Remove wristwatch, rings, and any other jewelry before handling the battery.
- Always turn the battery charger off before disconnecting the battery connections. Remove the negative lead first and reconnect it last when servicing the battery.

### BATTERY ACID

**⚠ WARNING: Sulphuric acid in batteries can cause severe injury or death!**

- When servicing the battery or checking the electrolyte level, wear rubber gloves, a rubber apron, and eye protection. Batteries contain sulfuric acid which is destructive. If it comes in contact with your skin, wash it off at once with water. Acid may splash on the skin or into the eyes inadvertently when removing electrolyte caps.

### TOXIC EXHAUST GASES

**⚠ WARNING: Carbon monoxide (CO) is a deadly gas!**

- Ensure that the exhaust system is adequate to expel gases discharged from the engine. Check the exhaust system regularly for leaks and make sure the exhaust manifolds are securely attached and no warping exists. Pay close attention to the manifold, water injection elbow, and exhaust pipe nipple.
- Be sure the unit and its surroundings are well ventilated.
- In addition to routine inspection of the exhaust system, install a carbon monoxide detector. Consult your boat builder or dealer for installation of approved detectors.
- For additional information refer to ABYC T-22 (educational information on Carbon Monoxide).

**⚠ WARNING: Carbon monoxide (CO) is an invisible odorless gas. Inhalation produces flu-like symptoms, nausea or death!**

- Do not use copper tubing in diesel exhaust systems. Diesel fumes can rapidly destroy copper tubing in exhaust systems. Exhaust sulfur causes rapid deterioration of copper tubing resulting in exhaust/water leakage.
- Do not install exhaust outlet where exhaust can be drawn through portholes, vents, or air conditioners. If the engine exhaust discharge outlet is near the waterline, water could enter the exhaust discharge outlet and close or restrict the flow of exhaust. Avoid overloading the craft.
- Although diesel engine exhaust gases are not as toxic as exhaust fumes from gasoline engines, carbon monoxide gas is present in diesel exhaust fumes. Some of the symptoms or signs of carbon monoxide inhalation or poisoning are:
  - Vomiting
  - Dizziness
  - Throbbing in temples
  - Muscular twitching
  - Intense headache
  - Weakness and sleepiness

### AVOID MOVING PARTS

**⚠ WARNING: Rotating parts can cause injury or death!**

- Do not service the engine while it is running. If a situation arises in which it is absolutely necessary to make operat-



## SAFETY INSTRUCTIONS

ing adjustments, use extreme care to avoid touching moving parts and hot exhaust system components.

- Do not wear loose clothing or jewelry when servicing equipment; avoid wearing loose jackets, shirts, sleeves, rings, necklaces or bracelets that could be caught in moving parts.
- Make sure all attaching hardware is properly tightened. Keep protective shields and guards in their respective places at all times.
- Do not check fluid levels or the drive belt's tension while the engine is operating.
- Stay clear of the drive shaft and the transmission coupling when the engine is running; hair and clothing can easily be caught in these rotating parts.

### HAZARDOUS NOISE

 **WARNING: High noise levels can cause hearing loss!**

- Never operate an engine without its muffler installed.
- Do not run an engine with the air intake (silencer) removed.
- Do not run engines for long periods with their enclosures open.

 **WARNING: Do not work on machinery when you are mentally or physically incapacitated by fatigue!**

### OPERATORS MANUAL

Many of the preceding safety tips and warnings are repeated in your Operators Manual along with other cautions and notes to highlight critical information. Read your manual carefully, maintain your equipment, and follow all safety procedures.

### ENGINE INSTALLATIONS

Preparations to install an engine should begin with a thorough examination of the American Boat and Yacht Council's (ABYC) standards. These standards are a combination of sources including the USCG and the NFPA.

Sections of the ABYC standards of particular interest are:

- H-2 Ventilation
- P-1 Exhaust systems
- P-4 Inboard engines
- E-9 DC Electrical systems

All installations must comply with the Federal Code of Regulations (FCR).

### ABYC, NFPA AND USCG PUBLICATIONS FOR INSTALLING DIESEL ENGINES

Read the following ABYC, NFPA and USCG publications for safety codes and standards. Follow their recommendations when installing your engine/generator.

**ABYC** (American Boat and Yacht Council)  
"Safety Standards for Small Craft"

Order From:

ABYC  
15 East 26th Street  
New York, NY 10010

**NFPA** (National Fire Protection Association)  
"Fire Protection Standard for Motor Craft"

Order From:

NFPA  
11 Tracy Drive  
Avon Industrial Park  
Avon, MA 02322

**USCG** (United States Coast Guard)  
"USCG 33CFR183"

Order From:

U.S. Government Printing Office  
Washington, D.C. 20404





## TABLE OF CONTENTS

<b>Introduction</b> .....	3	<b>Engine Shutoff</b> .....	32
Product Software.....	3	Engine with Manual Stop (Standard).....	32
Engine/Generator Model Designations.....	3	Optional Key Switch Shutoff (38B and 42B only).....	32
Notes, Cautions and Warnings.....	3	Installing and Adjusting the Key Switch	
Ordering Parts/Serial Number Location.....	3	Shutoff Solenoid.....	32
<b>Engine/Generator Specifications</b> .....	5	Key-Stop Solenoid System Operation	
<b>Testing for Overhaul</b> .....	6	Checking Procedure.....	32
How to Judge Engine Overhaul Period.....	6	<b>Engine Adjustments</b> .....	33
Cause of Low Compression.....	6	Tightening the Cylinder Head.....	33
Measuring Compression Pressure.....	6	Adjusting Valve Clearance.....	33
Overhaul Conditions.....	6	Adjusting Fuel Injection Timing.....	33
Disassembly.....	6	Adjusting No-Load Engine Speeds.....	34
Reassembly.....	7	<b>Lubrication System Service</b> .....	35
<b>Service Standards</b> .....	8	Description.....	35
<b>Technical Data</b> .....	11	Disassembly.....	35
Tightening Torque.....	11	Oil Filter and Oil Pump.....	35
General Screws.....	11	Inspection.....	35
Sealants.....	11	Oil Pump.....	35
<b>Engine Troubleshooting</b> .....	12	Reassembly.....	36
<b>Engine Parts Identification</b> .....	16	Testing the Oil Pressure.....	36
<b>Cylinder Head</b> .....	17	Oil Pressure Switch.....	36
Construction.....	17	<b>Fuel System</b> .....	37
<b>Cylinder Head Service</b> .....	18	Description.....	37
Disassembly.....	18	<b>Fuel System Service</b> .....	39
Inspection.....	18	Disassembly.....	39
Cylinder Head.....	18	Fuel Filter.....	39
Valve Guide.....	18	Fuel Lift Pump.....	39
Valve Seat.....	18	Fuel Injection Pump.....	39
Valve.....	19	Injector.....	40
Valve Spring.....	19	Inspection.....	40
Rocker Arm and Rocker Shaft.....	19	Fuel Filter.....	40
Reassembly.....	19	Fuel Lift Pump.....	40
Partial Reassembly.....	20	Fuel Injection Pump.....	40
Installation of Cylinder Head Assembly.....	20	Nozzle.....	40
Valve Clearance Adjustment.....	20	Reassembly.....	40
<b>Cylinder Block</b> .....	21	Fuel Filter.....	40
Construction.....	21	Fuel Lift Pump.....	40
<b>Cylinder Block Service</b> .....	23	Injection Pump.....	40
Disassembly.....	23	Installation and Adjustment of Fuel	
Inspection.....	23	Injection Pump.....	41
Cylinder Block.....	23	Injector.....	42
Piston, Piston Pin and Piston Rings.....	24	Adjustment and Installation of Nozzle	
Connecting Rod.....	25	Holder Assembly.....	42
Crankshaft.....	25	<b>Raw Water Cooling Circuit</b> .....	44
Main Bearings and Connecting Rod Bearings.....	25	Description.....	44
Gearcase.....	26	<b>Raw Water Pump Service</b> .....	45
Timing Gears and Lube Oil Pump Gear.....	26	Pump Overhaul – Raw Water Pump PN 33636.....	45
Camshaft.....	26	Disassembly.....	45
Fuel Injection Pump Camshaft.....	26	Inspection.....	45
Ball Bearings.....	26	Reassembly.....	45
Tappets.....	26	Pump Overhaul – Raw Water Pump PN 24143.....	46
Push Rods.....	26	Disassembly.....	46
Reassembly.....	26	Inspection.....	46
Reassembly.....	26	Reassembly.....	46
<b>Governor</b> .....	31	<b>Fresh Water Cooling Circuit</b> .....	47
Description.....	31	Description.....	47
Disassembly.....	31	<b>Fresh Water Cooling Service</b> .....	48
Inspection.....	31	Disassembly.....	48
Governor Lever.....	31	Inspection.....	48
Governor Spring.....	31	Water Pump.....	48
Needle Bearing.....	31	Thermostat.....	48
Reassembly and Adjustment.....	31		

(continued)



## TABLE OF CONTENTS

Reassembly .....	48	Engine Wiring Diagram-#36467 .....	70
Drive Belt Adjustment .....	48	Engine Wiring Schematic #36467 .....	71
<b>Admiral Control Panel</b> .....	49	Engine Wiring Diagram #36844 .....	72
Description .....	49	Engine Wiring Schematic #36844 .....	73
<b>Captain Control Panel</b> .....	50	Engine Wiring Diagram #39144 .....	74
Description .....	50	Engine Wiring Schematic #39144 .....	75
<b>Control Panel Troubleshooting</b> .....	51	<b>Standard Hardware Torques</b> .....	76
Tachometer/Hourmeter .....	51	<b>Metric Conversions</b> .....	77
Hourmeter Inoperative .....	51	<b>Generator Information</b> .....	78
Tachometer Inoperative .....	51	Use of Electric Motors .....	78
Tachometer Sticking .....	51	Required Operating Speed .....	78
Tachometer Inaccurate .....	51	Generator Frequency Adjustment .....	78
Manual Starter Disconnect (Toggle Switches) .....	52	Generator Maintenance .....	78
Troubleshooting Water Temperature and Oil Pressure Gauges .....	52	Generator Troubleshooting .....	78
<b>Control Panel – Early Models</b> .....	53	<b>WMD Generator</b> .....	79
Activation by Key Switch .....	53	Description .....	79
<b>Starter/Solenoid Service</b> .....	54	Disassembly .....	79
Description .....	54	Inspection .....	79
Adjustment and Repair .....	54	Reassembly .....	79
Pinion Gap Inspection .....	54	<b>WMD Generator Troubleshooting</b> .....	80
No-Load Test .....	54	No Electrical Output .....	80
Solenoid .....	55	Flash Field Coils .....	80
Starter Disassembly .....	55	Replacement of Field Coil(s) .....	81
Starter Inspection .....	56	Low Voltage Output .....	81
Solenoid .....	56	High Voltage Output .....	82
Inspecting the Armature .....	56	Solenoid with Throttle Linkage .....	82
Brush and Brush Holder Inspection .....	56	<b>WMD Generator AC Internal Wiring Diagrams</b> .....	83
Field Coil Inspection .....	57	<b>WMD Generator DC Electrical System</b> .....	84
Starter Adjustment and Reassembly .....	57	WMD Generator Wiring Diagram #24700 .....	84
<b>DC Electrical System</b> .....	58	WMD Generator Wiring Schematic #24700 .....	85
Description .....	58	<b>BT Generator</b> .....	86
Engine 12-Volt Control Circuit .....	58	Description .....	86
Charging System .....	58	<b>BT Generator Troubleshooting</b> .....	87
Alternator Troubleshooting .....	58	Residual Voltage Check .....	89
Checking for Proper Voltage .....	58	Bridge Rectifier .....	89
Battery Maintenance .....	59	Testing the Bridge Rectifier for Faults with an Ohmmeter .....	90
Glow Plugs .....	59	Internal Wiring Diagram .....	90
<b>Alternator/Regulator Service</b> .....	60	Component Resistance Values .....	91
Description .....	60	Models 11.0 & 12.5(A) BT .....	91
Alternator Troubleshooting .....	60	Component Resistance Checks .....	91
Testing the Charging Voltage .....	60	Exciter Stator Windings .....	91
Output Test .....	61	Exciter Rotor/Field .....	92
Disassembly .....	61	Main Stator Windings .....	93
Inspection .....	62	Compound Transformer .....	93
Diode .....	62	Selector Switch .....	93
Checking for Short Circuit .....	62	Bridge Rectifier Wiring .....	93
Checking for Open Circuit .....	62	No-Load Voltage Adjustment .....	94
Checking Diode Trio .....	62	Voltage/Hertz Connection Bar .....	94
Stator .....	63	<b>BT Generator AC Voltage Connections</b> .....	95
Field Coil (Rotor) .....	63	Generator Frequency .....	95
Checking Brush and Brush Spring .....	63	<b>BT Generator 6 Terminal Block</b> .....	96
Checking the Slip Ring .....	63	Wiring Connections .....	96
Regulator .....	63	<b>BT Generator DC Electrical System</b> .....	98
Reassembly .....	64	BT Generator Wiring Diagram #34651 .....	98
<b>Transmissions</b> .....	65	BT Generator Wiring Diagram #36412 .....	100
<b>DC Electrical System</b> .....	66	BT Generator Wiring Schematic #36412 .....	101
Engine Wiring Diagram #24666 .....	66		
Engine Wiring Schematic #24666 .....	67		
Engine Wiring Diagram #33685 .....	68		
Engine Wiring Schematic #33685 .....	69		





## INTRODUCTION

This service manual contains detailed information relating to the proper operation of the major components and systems of the engine or generator. Included are disassembly, inspection, service, and reassembly instructions for the guidance of suitably equipped and staffed marine engine service and rebuilding facilities. The necessary procedures should be undertaken only by such facilities and their personnel. Refer also to your Westerbeke parts catalog when performing an engine overhaul.

### PRODUCT SOFTWARE

Product software (tech data, parts lists, manuals, brochures and catalogs) provided from sources other than WESTERBEKE are not within WESTERBEKE'S control.

*WESTERBEKE CANNOT BE RESPONSIBLE FOR THE CONTENT OF SUCH SOFTWARE, MAKES NO WARRANTIES OR REPRESENTATIONS WITH RESPECT THERETO, INCLUDING ACCURACY, TIMELINESS OR COMPLETENESS THEREOF AND WILL IN NO EVENT BE LIABLE FOR ANY TYPE OF DAMAGE OR INJURY INCURRED IN CONNECTION WITH OR ARISING OUT OF THE FURNISHING OR USE OF SUCH SOFTWARE.*

WESTERBEKE customers should also keep in mind the time span between printings of WESTERBEKE product software and the unavoidable existence of earlier WESTERBEKE manuals. In summation, product software provided with WESTERBEKE products, whether from WESTERBEKE or other suppliers, must not and cannot be relied upon exclusively as the definitive authority on the respective product. It not only makes good sense but is imperative that appropriate representatives of WESTERBEKE or the supplier in question be consulted to determine the accuracy and currentness of the product software being consulted by the customer.

### ENGINE/GENERATOR MODEL DESIGNATIONS

This manual contains certain descriptions, procedures and specifications that vary depending on the engine/generator model. Where references to specific models are necessary, three basic model group designations are used:

A MODELS			B MODELS			C MODELS		
ENGINES	GENERATORS		ENGINES	GENERATORS		ENGINES	GENERATORS	
	60Hz	50Hz		60Hz	50Hz		60Hz	50Hz
388 Four	11.0 BTD	8.3 BTD	W-33	WMD 12.5	WMD 9.4	428 Four	12.5 BTDA	9.4 BTDA
W27	WMD 11.0	WMD 8.3	W-33A	12.5 BTD	9.4 BTD			
RD80								
W27A	11.0 BTD	8.3 BTD						

### NOTES, CAUTIONS AND WARNINGS

As this manual takes you through the service procedures, maintenance schedules, and troubleshooting of your marine engine/generator, critical information will be highlighted by NOTES, CAUTIONS, and WARNINGS. An explanation follows:

**NOTE:** *An operating procedure essential to note.*

**CAUTION:** *Procedures, which if not strictly observed, can result in the damage or destruction of your engine/generator.*

**WARNING:** *Procedures, which if not properly followed, can result in personal injury or loss of life.*

### ORDERING PARTS/SERIAL NUMBER LOCATION

Whenever replacement parts are needed for engines, always provide the engine model number and engine serial number as they appear on the silver and black identification nameplate located on the manifold. For generators, provide the generator model number, engine serial number, and generator serial number as they appear on the silver and black decal located on the generator end.



The engine serial number can also be found stamped into the engine block just above the injection pump. The generator serial number is stamped into the generator housing on the flat surface on the left side of the generator.

You must provide us with this information so we may properly identify your engine/generator. In addition, include a complete part description and part number for each part needed (see the separately furnished Parts List). Also insist upon WESTERBEKE packaged parts because *will fit* or generic parts are frequently not made to the same specifications as original equipment.

**NOTE:** *Component locations in this manual are referenced from the front of the engine which is the pulley/drive belt end. Left and right sides are determined as follows: imagine straddling the engine, facing in the same direction as the front of the engine: the left side is at your left, the right side is at your right.*



## INTRODUCTION

Owners may find it convenient to fill in the data on the decal or identification nameplate shown below to provide a quick reference when using this service manual.

SPECIFICATION	50 HZ.	60 HZ.
MODEL .....		
RPM .....		
KW .....		
KVA .....		
VOLTS .....		
AMPS .....		
ENG. HP .....		
ENG. SER. NO.		
GEN. SER. NO.		
PF/PHASE .....	/	
WIRES .....		
RATING .....		
INSUL. CLASS .....		
TEMP. RISE .....		
BATTERY .....		
C.I.D. ....		

GENERATOR DECAL



PROPULSION ENGINE IDENTIFICATION NAMEPLATE



## ENGINE/GENERATOR SPECIFICATIONS

A MODELS			B MODELS			C MODELS		
ENGINES	GENERATORS		ENGINES	GENERATORS		ENGINES	GENERATORS	
	60Hz	50Hz		60Hz	50Hz		60Hz	50Hz
38B Four	11.0 BTD	8.3 BTD	W-33	WMD 12.5	WMD 9.4	42B Four	12.5 BTDA	9.4 BTDA
W27	WMD 11.0	WMD 8.3	W-33A	12.5 BTD	9.4 BTD			
RD80								
W27A	11.0 BTD	8.3 BTD						

<b>Engine Type</b>	Vertical, inline, 4-cycle, OHV, freshwater-cooled with heat exchanger, diesel engine.	
<b>Cylinders</b>	4	
<b>Bore &amp; Stroke</b>	2.87 x 3.07 in. (73 x 78 mm)	3.07 x 3.07 in. (78 x 78 mm)
<b>Total Displacement</b>	79.6 cu. in. (1.30 liters)	90.9 cu. in. (1.49 liters)
<b>Combustion Chamber</b>	Swirl chamber type	
<b>Compression Ratio</b>	23:1	
<b>Injection Order</b>	1-3-4-2	
<b>Injection Timing</b>	Engines: 23° ± 1.5°; Generators: 19° ± 1.5°	
<b>Injection Pump</b>	Bosch M type	
<b>Injection Nozzle</b>	Throttle type	
<b>Governor</b>	Centrifugal flyweight type	
<b>Fuel</b>	Diesel #2 cetane rating 45 or higher	
<b>Lubrication</b>	Forced lubrication (trochoid pump)	
<b>Oil Filter</b>	Paper-element filter (full flow type) .5 liter capacity	
<b>Sump Capacity</b>	5.0 quarts (4.8 liters) not including filter. Filter requires approximately .5 quarts (.5 liters)	
<b>Fresh Water Pump</b>	Centrifugal type	
<b>Fresh Water Coolant Capacity (approximate)</b>	8.0 quarts (7.5 liters)	
<b>Raw Water Pump</b>	Positive displacement (Neoprene impeller)	
<b>Starter Motor</b>	12 volts – 1.6 kW reduction type	
<b>DC Alternator</b>	12 volt - 50 amp – internal voltage regulator	
<b>Inclination Angle</b>	15° Continuous (in all directions) 20° Temporary (20 minutes)	
<b>Starting Battery</b>	12 volt 300 C.C.A. or greater	
<b>Compression Value</b>		
Standard	455 psi at 280 rpm (32 kg/cm <sup>2</sup> )	
Minimum	370 psi at 280 rpm (26 kg/cm <sup>2</sup> )	
Overhaul	312 psi at 280 rpm (22 kg/cm <sup>2</sup> )	
<b>Difference between Cylinders</b>	35.5 psi (2.5 kg/cm <sup>2</sup> )	



## TESTING FOR OVERHAUL

### HOW TO JUDGE ENGINE OVERHAUL PERIOD

#### Cause of Low Compression

Generally, the time at which an engine should be overhauled is determined by various conditions such as lowered engine power output, decreased compression pressure, and increased fuel and oil consumption. The lowered engine power output, in the case of diesel engines, is not necessarily due to trouble with the engine itself, but is sometimes caused by injector nozzle wear or injection pump wear. It is most reasonable to judge by a decrease in compression pressure. The decrease in compression pressure is caused by many factors. It is, therefore, necessary to determine a cause or causes on the basis of data of periodic inspection and maintenance. Oil analysis on a seasonal basis is a good means of monitoring engine internal wear. When caused by worn cylinders or piston rings, the following symptoms will occur:

- Low engine power output
- Increased fuel consumption
- Increased oil consumption
- Hard engine starting
- Noisy engine operation

These symptoms often appear together. Increased fuel consumption and hard engine starting can result also from excessive fuel injection, improper injection timing, and wear of plugs and nozzles. They are caused also by defective electrical devices such as the battery, alternator, starter and glow plugs. Therefore it is desirable to judge the optimum engine overhaul time by the lowered compression pressure caused by worn cylinders and pistons plus increased oil consumption. In diesel engines, satisfactory combustion is obtained only under sufficient compression pressure. If an engine lacks compression pressure, incomplete combustion of fuel will take place even if other parts of the engine are operating properly. To judge the period of engine overhaul, it is important to measure the engine compression pressure regularly. At the same time, the engine speed at which measurement of compression pressure is made should be checked because the compression pressure varies with engine rpm.

The engine rpm can be measured at the front end of the crankshaft.

#### Measuring Compression Pressure

To check the compression pressure, follow this procedure:

1. Warm the engine.
2. Remove all the fuel injectors or all the glow plugs from the cylinder block.
3. Disconnect the fuel solenoid from the throttle arm (generator models only).
4. Place the stop lever in the OFF position (propulsion models only).

5. Install a pressure gauge adapter in the first injector hole or glow plug hole to be tested.
6. Connect the pressure gauge to the adapter.
7. Crank the engine with the starter motor until the pressure reaches a maximum value. Read the engine rpm and the pressure gauge when the starter rotation has become stable.
8. Repeat the above procedure for each cylinder.
9. If the compression differs by more than 42.7 psi (3.0 kg/cm<sup>2</sup>) at 200 rpm, then determine the cause of the low pressure, and repair as necessary.

**NOTE:** Do not guess the conditions of other cylinders from a result of testing one cylinder. Be sure to measure the compression pressure for each cylinder. Look for cylinders with dramatically (at least 20%) lower compression than the average of the other cylinders. If the weak cylinder is flanked by healthy cylinders, the problem is either valve- or head-gasket related. Very low compression in an adjacent cylinder points to gasket failure. Abnormally high readings on all cylinders indicate heavy carbon accumulations, a condition that might be accompanied by high pressures and noise.

**NOTE:** In case of severe vibrations and detonation noise, have the injectors overhauled by an authorized fuel injection service center. Poor fuel quality, contaminates, and loss of positive fuel pressure to the injection pump will result in injector faults.

#### OVERHAUL CONDITIONS

Compression pressure tends to increase a little in a new engine until piston rings and valve seats have been broken in. Thereafter, it decreases gradually with the progress of wear of these parts.

When decrease of compression pressure reaches the repair value, the engine must be overhauled.

The engine requires overhaul when oil consumption is high, blowby evident, and compression valves at minimum or below. Engine compression should be 32 kg/cm<sup>2</sup> (at 280 rpm). See SERVICE STANDARDS chart.

**NOTE:** The SERVICE STANDARDS chart gives the values for repair or replacement of the engine components. Refer to these values and measurements during engine overhaul.

#### Disassembly

1. Before disassembly and cleaning, carefully check for defects which cannot be found after disassembly and cleaning.
2. Drain water, fuel and oil before disassembly.
3. Clean or wash the engine exterior.
4. Do not remove or disassemble the parts that require no disassembly.



## TESTING FOR OVERHAUL

5. Perform disassembly in a proper order using proper tools. Keep disassembled parts in order. Apply oil when necessary. Take special care to keep the fuel system parts free from the intrusion of dust and dirt.

### Reassembly

1. Prepare all parts necessary for reassembly.
2. Clean or wash the parts. Apply oil on surfaces where needed or specified.
3. Carefully check gaskets, packings and oil seals even if not specified to check. Replace with new ones if defective.
4. Be sure to install in proper directions and positions. (Pay attention to dowel pins, mating marks and specified directions.) Where tightening torque is not specified, tighten evenly to an ordinary torque. Apply sealant where specified.
5. After completion of the reassembly, manually rotate the engine crankshaft two complete revolutions to ensure there is no binding or obstructions. Prepare for starting the engine and idle the engine sufficiently for a test run.

## SERVICE STANDARDS

These SERVICE STANDARDS specify the values at which the engine components will require REPAIR (replacement is optional), or REPLACEMENT (due to maximum component wear). It is important to observe these standards for your engine/generator, and to take action when necessary to maintain a high level of safety, dependability and performance.

A MODELS			B MODELS			C MODELS		
ENGINES	GENERATORS		ENGINES	GENERATORS		ENGINES	GENERATORS	
	60Hz	50Hz		60Hz	50Hz		60Hz	50Hz
388 Four	11.0 BTD	8.3 BTD	W-33	WMD 12.5	WMD 9.4	428 Four	12.5 BTDA	9.4 BTDA
W27	WMD 11.0	WMD 8.3	W-33A	12.5BTD	9.4 BTD			
RD80								
W27A	11.0 BTD	8.3 BTD						

All measurements are in mm unless otherwise noted.  
To convert mm to inches, multiply by .03937

DESCRIPTION	MODELS			STANDARD VALUE	REPAIR (or replacement) Required at:	REPLACEMENT Required at:
	A	B	C			
<b>ENGINE COMPRESSION PRESSURE</b>	A	B	C	32 kg/cm <sup>2</sup> (at 280 rpm)	26 kg/cm <sup>2</sup>	
<b>INTER-CYLINDER DIFFERENCE (max)</b>	A	B	C	2.5 kg/cm <sup>2</sup>		
<b>INJECTION ORDER</b>	A	B	C	1 - 3 - 4 - 2		
<b>INJECTION TIMING (BTDC on compression stroke)</b>	A	B	C	23°±1.5° (Propulsion) 19°±1.5° (Generator)		
<b>CYLINDER HEAD</b>						
Bottom surface distortion	A	B	C	Within 0.05	0.1	
Valve seat angle (IN and EX)	A	B	C	45°		
Valve seat width (IN and EX)	A	B	C	1.3 - 1.8	2.5	
Valve seat sinkage	A	B	C	.12 - .13		-1
<b>VALVE CLEARANCE (IN and EX)</b>	A	B	C	0.25 (when engine is cold)		
<b>VALVE</b>						
Stem O.D.	A		C	6.6		
		B		8		
Stem to guide clearance						
Intake	A	B	C	.012		0.10
Exhaust	A	B	C	.025		0.15
Valve face angle	A	B	C	45°		
Valve head thickness (margin width)	A		C	1.0		0.5
		B		1.5		0.5
<b>VALVE SPRING</b>						
Free length	A		C	43	41.7	
		B		45.85	44.5	
Installed load/length	A		C	14.0 kg ± 0.7 kg/36 mm		-15%
		B		27.9 kg ± 1.4 kg/37.3 mm		-15%
Squareness	A	B	C	1.5°		3°
<b>ROCKER ARM</b>						
Arm to shaft clearance	A	B	C			-0.2
<b>CYLINDER BLOCK</b>						
Camshaft hole I.D.						
Front bushing	A	B	C	45		
Cylinder bore	A		C	73	+0.2	+ .95 Replace block or sleeve
		B		78	+0.2	+ .95 Replace block or sleeve
Cylinder bore oversize finish tolerance	A	B	C	0 to 0.03 for each oversize		
Taper of cylinder	A	B	C	within 0.01		

**NOTE:** Valve seats are a part of the cylinder head. A machine shop can install valve seats and cut the seats to properly fit the valves.

(continued)



## SERVICE STANDARDS

All measurements are in mm unless otherwise noted.  
To convert mm to inches, multiply by .03937

DESCRIPTION	MODELS			STANDARD VALUE	REPAIR (or replacement) Required at:	REPLACEMENT Required at:
<b>PISTON</b>						
O.D. (skirt end)	A			73		
		B	C	78		
Piston to cylinder clearance	A	B	C	0.07 – 0.08	.178	0.3 B/O
Oversize	A	B	C	0.25, 0.50, 0.75		
<b>PISTON PIN</b>						
Type	A		C	Semi-floating type		
		B		Full-floating type		
O.D.	A		C	19		
		B		23		
Piston to pin clearance		B		-.002 (slight force fit-heat)		0.08
Pin to connecting rod clearance	A		C	Press-fit load: 500 – 1500 kg		
		B		.014 – .038	.015	.015
Piston protrusion above block surface	A	B	C	0.6 – 1.1		
<b>PISTON RINGS</b>						
Number of compression rings	A	B	C	3 (No. 1: chrome plated barrel type, semi-keystone. No. 2 and No. 3: taper ring.)		
Number of oil rings	A	B	C	1 (chrome plated with coil expander)		
Ring side clearance						
Compression No. 1	A	B	C	.06 – .11		0.3
No. 2 & 3	A	B	C	.05 – .09		0.2
Oil ring	A	B	C	.03 – .07		0.2
Ring gap	A	B	C	.22 – .40	1.25	1.5
<b>CONNECTING ROD</b>						
Bend and distortion	A	B	C			0.15
Sideplay clearance	A	B	C	0.1 – 0.35		0.5
<b>CONNECTING ROD BEARING</b>						
Standard Type	A	B	C	Kelmet metal with back metal		
Oil clearance	A	B	C	0.035 – 0.05	0.06	0.15
Undersize	A	B	C	0.25, 0.50, 0.75		
<b>CRANKSHAFT</b>						
Bend	A	B	C			0.05
End play	A	B	C	0.06 – 0.3	-0.3	
Main O.D.	A		C	52	-0.15	-0.90
		B		57	-0.15	-0.90
Conn. O.D.	A		C	42	-0.15	-0.90
		B		48	-0.15	-0.90
Undersize finish tolerance						
Main (common to all)	A		C	0 – 0.015		
		B		0.040 – 0.055		
Conn. (common to all)	A	B	C	-0.035 – -0.050		
<b>MAIN BEARING</b>						
Standard type	A	B	C	Kelmet metal with back metal (flanged metal for center bearing only)		
Oil clearance	A	B	C	0.04 – 0.05	.06	0.10
Undersize	A	B	C	0.25, 0.50, 0.75		



(continued)

## SERVICE STANDARDS

All measurements are in mm unless otherwise noted.  
To convert mm to inches, multiply by .03937

DESCRIPTION	MODELS			STANDARD VALUE	REPAIR (or replacement) Required at:	REPLACEMENT Required at:
<b>CAMSHAFT</b>						
Front bearing	A	B	C	Lead bronze alloy with back metal		
Oil clearance	A	B	C	0.04 – 0.08	0.10	0.15
Cam lobe height (IN and EX)	A	B	C	35.6 – 35.7		-1.0
<b>PUMP CAMSHAFT</b>						
Front bearing	A	B	C	Ball bearing		
Cam lobe height	A	B	C	44		-1.0
<b>TAPPET</b>						
O.D.	A	B	C	23		
Tappet to cylinder block clearance	A	B	C	.025 – .050		0.15
<b>PUSH ROD</b>						
Bend	A	B	C	Within 0.3		

### LUBRICATION

<b>ENGINE OIL</b>						
Oil specification						
API service classification	A	B	C	Class CF or CG-4		
Viscosity above 20°C	A	B	C	SAE30 or 10W-30		
5° to 20°C	A	B	C	SAE20 or 10W-30		
below 5°C	A	B	C	SAE 10W-30		
<b>OIL PUMP</b>						
Trochoid type	A	B	C			
Check valve opening pressure	A	B	C	4 ± 0.4 kg/cm <sup>2</sup> (at 500 rpm of pump speed)		
Outer rotor to body clearance	A	B	C	0.15 – 0.2		0.3
Outer rotor to inner rotor clearance	A	B	C	0.05 – 0.12		0.25
Rotor to cover clearance	A	B	C	0.03 – 0.07		0.20
<b>OIL PRESSURE SWITCH</b>						
Contact closing pressure						
Engine	A	B	C	4 – 6 psi normally open		
Generator	A	B	C	4 – 6 psi normally open		

### FUEL SYSTEM

<b>FUEL INJECTION PUMP</b>						
Model: ND-PFT4M	A	B	C			
At smoke set (SS)						
Pump speed	A		C	1500 rpm: 27.5 ± 1.0 mm <sup>3</sup> /st		
Pump speed		B		1500 rpm: 38 ± 1.0 mm <sup>3</sup> /st		
At start set (MS)						
Pump speed	A		C	150 rpm: 34 ± 5 mm <sup>3</sup> /st		
Pump speed		B		150 rpm: 36 ± 7.5 mm <sup>3</sup> /st		
Difference from reference cylinder	A	B	C	Within 2 mm <sup>3</sup> /rev. cylinder		
Prestroke	A	B	C	2.2 ± 0.1		
<b>NOZZLE</b>						
Throttle type						
Model: ND-DN4SD24	A	B	C			
Injection start pressure	A	B	C	120 ± 10 kg/cm <sup>2</sup>		





## TECHNICAL DATA

### TIGHTENING TORQUE

DESCRIPTION	MODELS			TYPE/QUANTITY	TIGHTENING TORQUE (kg-m)
CYLINDER HEAD BOLT	A		C	M12 bolt (10)	11.5 – 12.5 (wet)
	A		C	M10 bolt (4)	6.5 – 8.0 (wet)
		B		M14 bolt (10)	15 – 16
		B		M14 bolt (4) tappet side	10 – 11
CRANKSHAFT PULLEY NUT	A		C	M18t	15 – 20
		B		M20	20 – 25
MAIN BEARING CAP BOLT	A	B	C		5 – 5.5
CONNECTING ROD CAP NUT	A		C		3.2 – 3.5
CONNECTING ROD CAP BOLT		B			5.5 – 6.0
FLYWHEEL MOUNTING BOLT (with flange)	A	B	C		13 – 14
(8T) (WITH WASHER: OLD)	A	B	C		11.5 – 12.5
OIL DRAIN HOSE BANJO BOLT	A	B	C		5 – 6
OIL FILTER	A	B	C		1.1 – 1.3
FUEL INJECTION PUMP					
Delivery valve holder	A	B	C		4 – 5
NOZZLE HOLDER					
Holder mounting bolt	A	B	C		1.5 – 2
Holder body and retaining nut	A	B	C		6 – 8
GLOW PLUG	A	B	C		1.5 – 2

### GENERAL SCREWS

BOLT DIA.	BOLT HEAD MARK		
	4	7	10
M6	0.3 – 0.5	0.8 – 1.0	1.0 – 1.3
M8	1.0 – 1.3	1.5 – 2.2	2.5 – 3.5
M10	1.8 – 2.5	3.0 – 4.2	5.0 – 7.0
M12	3.0 – 4.2	5.5 – 7.5	9.5 – 12.0
M14	5.0 – 7.0	8.0 – 11.0	16.0 – 19.0

### SEALANTS

PARTS REQUIRING SEALANT	SURFACES REQUIRING SEALANT (where to mount sealant coated parts)	SEALANT
Taper screw 1/2 "	Thread portion (Gear case)	Liquid Teflon
Taper screw 1/4 "	Thread portion (Cylinder block right side, pump cover)	Liquid Teflon
Taper screw 1/8 "	Thread portion (Cylinder head rear surface)	Liquid Teflon
Water drain plug	Thread portion (Cylinder block right side, rear middle portion)	Liquid Teflon
Oil pressure switch	Thread portion (Cylinder block right side surface)	Liquid Teflon
Side seal	Periphery (Main bearing caps No. 1 and No. 5)	Permatex #6B
Bearing cap No. 1	Contact surface with cylinder block	Permatex #6B



## ENGINE TROUBLESHOOTING

The following troubleshooting table describes certain problems relating to engine service, the probable causes of these problems, and the recommendations to overcome these problems.

*Note: The engine's electrical system is protected by a 20-ampere manual reset circuit breaker located on a bracket on the left front side of the engine. The preheat solenoid is mounted on the same bracket.*

PROBLEM	PROBABLE CAUSE	VERIFICATION/REMEDY
<b>HARD STARTING</b>	<b>LOW CRANKING SPEED</b> 1. Engine oil viscosity too high. 2. Run-down battery. 3. Worn battery. 4. Battery terminals loosely connected. 5. Defective starter. 6. Defective main drive section.	1. Replace engine oil with less viscous oil. 2. Recharge battery. 3. Replace battery. 4. Clean terminals and correct cables. 5. Repair or replace starter. 6. Check clutch for disengagement.
	<b>DEFECTIVE INJECTION SYSTEM</b> 1. Air trapped in fuel passage. 2. Clogged fuel filter. 3. Low injection pressure. 4. Inadequate spray. 5. Injection pump delivering insufficient fuel. 6. Injection too early.	1. Bleed air from fuel system. 2. Clean or replace filter. 3. Adjust injection pressure. 4. Clean or replace nozzle. 5. Repair or replace injection pump. 6. Adjust injection timing.
	<b>MAIN ENGINE TROUBLES</b> 1. Low compression. <ul style="list-style-type: none"> <li>a. Incorrect valve clearance.</li> <li>b. Inadequate contact of valve seat.</li> <li>c. Valve stem seized.</li> <li>d. Broken valve spring.</li> <li>e. Compression leaks through cylinder head gasket.</li> <li>f. Piston ring seized.</li> <li>g. Worn piston ring and cylinder.</li> </ul> 2. Burnt glow plug. 3. Faulty glow plug operation. 4. Incorrect governor lever position.	<ul style="list-style-type: none"> <li>a. Adjust valve clearance.</li> <li>b. Lap valve.</li> <li>c. Replace valve and valve guide.</li> <li>d. Replace valve spring.</li> <li>e. Replace gasket.</li> <li>f. Replace piston and piston ring.</li> <li>g. Overhaul engine.</li> </ul> 2. Replace glow plug. 3. Check glow plugs and solenoid. 4. Set lever to starting position.
<b>LOW OUTPUT</b>	<b>LOW COMPRESSION</b>	<b>See HARD STARTING</b>
	<b>INJECTION SYSTEM OUT OF ADJUSTMENT</b> 1. Incorrect injection timing. 2. Insufficient injection. 3. Low injection pressure.	1. Adjust injection timing. 2. Repair or replace injection pump. 3. Check injection nozzle and adjust pressure.
	<b>INSUFFICIENT FUEL</b> 1. Air trapped in fuel system. 2. Clogged filter. 3. Contaminated fuel tank.	1. Check and retighten connector. 2. Clean or replace filter. 3. Clean tank.
	<b>INSUFFICIENT INTAKE AIR</b> 1. Clogged air cleaner.	1. Clean or replace air cleaner.

*(continued)*



## ENGINE TROUBLESHOOTING

PROBLEM	PROBABLE CAUSE	VERIFICATION/REMEDY
<b>LOW OUTPUT (cont.)</b>	<b>OVERHEATING</b> 1. Low coolant level. 2. Loose V-belt. 3. Incorrect injection timing. 4. Low engine oil level.	1. Add coolant. 2. Adjust or replace V-belt. 3. Adjust injection timing. 4. Add engine oil.
<b>EXCESSIVE OIL CONSUMPTION</b>	<b>OIL LEAKAGE</b> 1. Defective oil seals. 2. Broken gear case gasket. 3. Loose gear case attaching bolts. 4. Loose drain plug. 5. Loose oil pipe connector. 6. Broken rocker cover gasket. 7. Loose rocker cover attaching bolts.	1. Replace oil seals. 2. Replace gasket. 3. Retighten bolts. 4. Retighten plug. 5. Retighten oil connections. 6. Replace gasket. 7. Retighten attaching bolts.
	<b>OIL LEVEL RISING</b> 1. Incorrectly positioned piston ring gaps. 2. Displaced or twisted connecting rod. 3. Worn piston ring. 4. Worn piston or cylinder.	1. Correct ring gap positions. 2. Replace connecting rod. 3. Replace ring. 4. Replace piston and rebore cylinder.
	<b>OIL LEVEL FALLING</b> 1. Defective stem seal. 2. Worn valve and valve guide.	1. Replace stem seal. 2. Replace a valve and valve guide.
<b>EXCESSIVE FUEL CONSUMPTION</b>	<b>ENGINE BODY TROUBLES</b> 1. Noisy knocking. 2. Smoky exhaust. 3. Moving parts nearly seized or excessively worn. 4. Poor compression. 5. Improper valve timing. 6. Improper valve clearance.	1. See <i>KNOCKING</i> . 2. See <i>SMOKY EXHAUST</i> . 3. Repair or replace. 4. See <i>LOW COMPRESSION; HARD STARTING</i> . 5. Adjust. 6. Adjust.
	<b>INSUFFICIENT INTAKE AIR</b> 1. Air intake obstructed.	1. Clean or remove obstruction.
	<b>NOZZLE TROUBLES</b> 1. Seized nozzle. 2. Worn nozzle.	1. Replace. 2. Replace.
	<b>IMPROPER FUEL</b>	Replace with proper fuel.
	<b>FUEL LEAKS</b>	Find fuel leaks.
<b>SMOKY EXHAUST</b>	<b>WHITISH OR PURPLISH</b> 1. Excessive engine oil. 2. Excessive rise of oil into combustion chamber. <ul style="list-style-type: none"> <li>a. Poor piston contact.</li> <li>b. Seized piston ring.</li> <li>c. Excessive piston-to-cylinder clearance.</li> </ul>	1. Correct oil level. <ul style="list-style-type: none"> <li>a. Check.</li> <li>b. Replace or clean.</li> <li>c. Replace or correct.</li> </ul>

(continued)



## ENGINE TROUBLESHOOTING

PROBLEM	PROBABLE CAUSE	VERIFICATION/REMEDY
<b>SMOKY EXHAUST (cont.)</b>	<b>WHITISH OR PURPLISH (cont.)</b> d. Worn valve stem and valve guide. e. Low engine oil viscosity. f. Excessive oil pressure. 3. Injection timing is too late. 4. Insufficient compression.	d. Replace. e. Replace. f. Correct. 3. Adjust. 4. See <i>LOW COMPRESSION; HARD STARTING</i> .
	<b>BLACKISH OR DARK GRAYISH</b> 1. Engine body troubles. a. Poor compression. b. Improper valve clearance. 2. Insufficient intake air (air cleaner clogged). 3. Improper fuel.	a. See <i>LOW COMPRESSION; HARD STARTING</i> . b. Adjust. 2. Clean air cleaner. 3. Replace with proper fuel.
<b>ABNORMAL SOUND OR NOISE</b>	<b>CRANKSHAFT AND MAIN BEARING</b> 1. Badly worn bearing. 2. Badly worn crankshaft. 3. Melted bearing.	1. Replace bearing and grind crankshaft. 2. Grind crankshaft. 3. Replace bearing and check lubrication system.
	<b>CONNECTING ROD AND CONNECTING ROD BEARING</b> 1. Worn connecting rod big end bearing. 2. Worn crankpin. 3. Bent connecting rod.	1. Replace bearing. 2. Grind crankshaft. 3. Correct bend or replace.
	<b>PISTON, PISTON PIN, AND PISTON RING</b> 1. Worn cylinder. 2. Worn piston pin. 3. Piston seized. 4. Piston seized and rings worn or damaged.	1. Rebore cylinder to oversize and replace piston. 2. Replace piston. 3. Replace piston and rebore cylinder. 4. Replace piston and rings.
	<b>VALVE MECHANISM</b> 1. Worn camshaft. 2. Excessive valve clearance. 3. Worn timing gear. 4. Worn fan pulley bearing.	1. Replace. 2. Adjust. 3. Replace. 4. Replace.
<b>ROUGH OPERATION (HUNTING)</b>	<b>INJECTION PUMP SYSTEM</b> 1. Uneven injection. 2. Control rack malfunctioning. 3. Worn delivery valve. 4. Inadequate injection nozzle spray.	1. Adjust injection or replace parts. 2. Disassemble, check and correct injection pump. 3. Replace. 4. Replace injection nozzle.
	<b>GOVERNING SYSTEM</b> 1. Governor lever malfunctioning. 2. Fatigued governor spring.	1. Check governor shaft and correct operation. 2. Replace.

*(continued)*



## ENGINE TROUBLESHOOTING

PROBLEM	PROBABLE CAUSE	VERIFICATION/REMEDY
<b>KNOCKING</b>	<b>ENGINE KNOCKS WITHOUT MUCH SMOKE</b> 1. Faulty injector. 2. Bent rod. 3. Main engine troubles. a. Overheated cylinder. b. Carbon deposits in cylinder. 4. Too early injection timing. 5. Too high injection pressure. 6. Improper fuel.	1. Foul exhaust – rebuild injector. 2. Fuelish exhaust – check compression, repair.  a. See <i>OVERHEATING; LOW OUTPUT</i> . b. Clean. 4. Correct. 5. Correct. 4. Replace with proper fuel.
	<b>KNOCKING WITH DARK SMOKE</b> 1. Poor compression. 2. Injection pump malfunctioning. a. Worn plunger. b. Pinion is not in mesh with control rack. c. Broken delivery valve spring. d. Worn delivery valve seat.  3. Improper nozzle. a. Poor spray. b. Poor chattering. c. After-injection drip. d. Nozzle needle valve seized.	1. See <i>LOW COMPRESSION; HARD STARTING</i> .  a. Replace. b. Correct. c. Replace. d. Replace.  a. Clean or replace nozzle. b. Repair or replace nozzle. c. Repair or replace nozzle. d. Replace.
<b>INTERMITTENT EXHAUST SOUND</b>	1. Fuel filter clogged. 2. Fuel pipe sucks air. 3. Water mixed in fuel	1. Clean or replace. 2. Retighten pipe joints or replace pipe. 3. Replace fuel.
<b>OVERHEATING</b>	1. V-belt slackening or slippery with oil. 2. Damaged water pump. 3. Lack of coolant. 4. Faulty thermostat. 5. Low oil level or poor oil quality. 6. Knocking. 7. Moving parts seized or damaged.	1. Adjust, replace or clean. 2. Replace. 3. Add. 4. Replace. 5. Add or change. 6. See <i>KNOCKING</i> . 7. Replace.

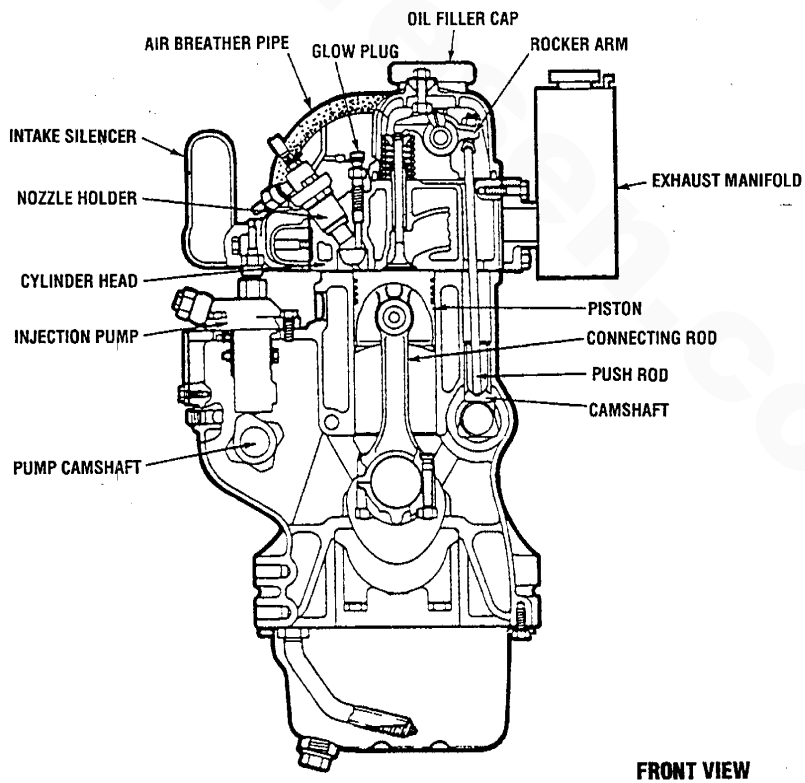
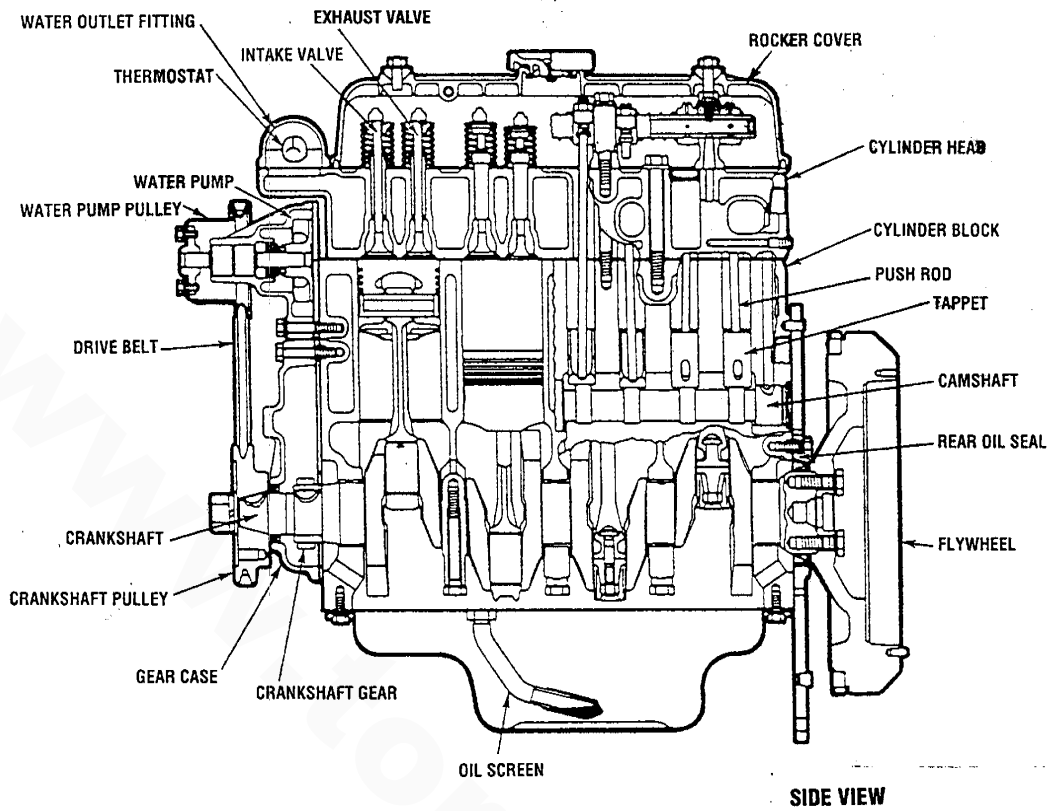

**CONSTRUCTION**

The *cylinder head* is of an overhead valve type made of high-rigidity special cast iron and has an excellent cooling effect. The cross-flow type cylinder head, provided with its intake port on the right-hand side and the exhaust port on the left-hand side, ensures high intake-exhaust efficiency.

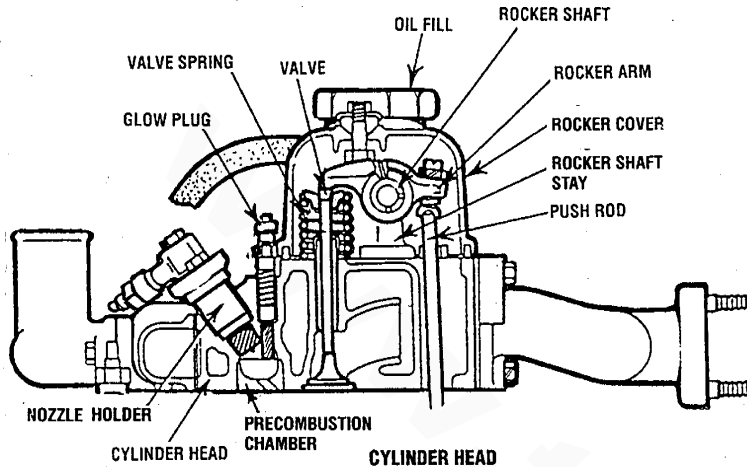

The *precombustion chamber* is of a swirl chamber type (*Ricardo*) made of heat resisting steel and is press fitted in the cylinder head. This chamber, therefore, requires no disassembly.

*Intake and exhaust valve guides* are made of sintered alloy and are commonly usable in either port. The valve guides are oil-impregnated to improve wear resistance.

*Valve seats*, when needed, can be installed by a competent and knowledgeable machine shop.

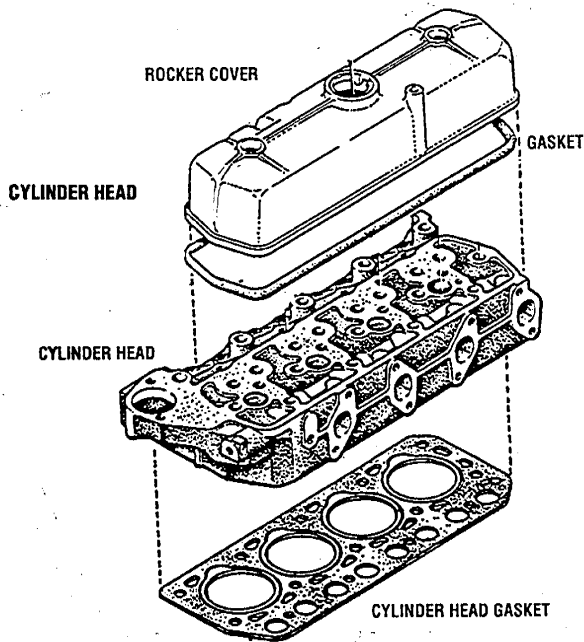

The *cylinder head gasket* is made of carbon graphite. It is provided with stainless steel sheet grommets around the bores for improved heat and pressure resistance. The gasket requires no sealant when assembled.

*Intake valves* are made of heat-resisting steel and have a large-diameter head to provide greater intake efficiency. The heads of the exhaust valves are protected against high temperatures by a special heat-resisting steel facing welded to the valve head.

*Valve springs* are coated with red enamel which marks the rocker arm end to aid in proper placement of the spring during assembly. The spring retainer and retainer lock are common to intake and exhaust valves. The valve stem seal at the top of the valve guide prevents downward seepage of oil into the combustion chamber. *The high speed engines (3000 rpm and over) are provided with a valve spring seat between the valve springs and cylinder head.*

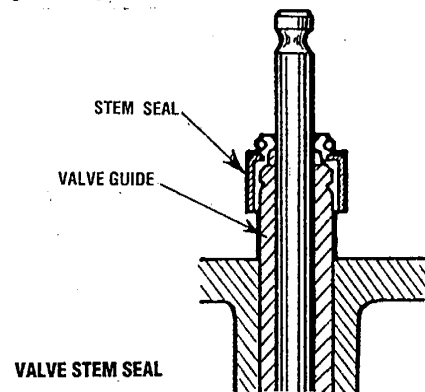

*Rocker arm, rocker shaft and stay.* The rocker arms are made of special cast iron and are gas carbonized on the entire surface. An oil hole is on the upper side of each arm. The rocker arm shaft is a carbon steel tube, the interior of which forms a lubricant passage. The rocker arm area of the shaft is induction-hardened. Four rocker shaft stays of aluminum alloy casting are used. The rearmost stay forms an oil passage connected to the cylinder head. The rear stay is identical to the front stay.

*Intake manifold and exhaust manifold.* An intake manifold with its gasket is on the right side of the cylinder head and an exhaust manifold is on the left side of the cylinder head. The shape of each manifold depends on the engine model.

*The crankcase vent system* allows blowby gases produced in the cylinder block to circulate inside the engine, thus preventing them from exhausting. This system leads blowby gases from the cylinder block through tappet holes and push rod holes into the rocker cover and, further, through the air breather pipe (rubber pipe) into the air intake manifold, so that blowby gases are carried into the combustion chamber and are burned during combustion.

**DISASSEMBLY**

1. Remove the air breather pipe. Remove the water bypass hose if provided.
2. Remove the fuel injection lines.
3. Remove both the intake manifold and exhaust manifold assemblies.
4. Remove the rocker cover.
5. Remove the rocker arms and rocker shaft as an assembly.
6. Remove the push rods.
7. Remove the cylinder head assembly by loosening the head bolts in the numerical order shown below.

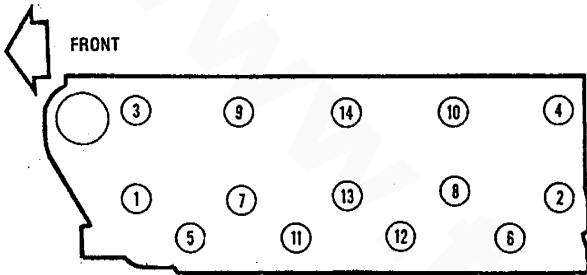

**CYLINDER HEAD BOLTS LOOSENING SEQUENCE**

8. Remove the cylinder head gasket.
9. Partly disassemble the cylinder head assembly as follows:
  - a. Remove the thermostat housing. Remove the thermostat and thermostat gasket.
  - b. Remove the fuel injectors and sealing washers.
  - c. Remove the glow plug lead wires and remove the glow plugs.
  - d. Using a valve spring compressor, compress the spring for each valve. Remove the retainer lock and then remove the retainer, spring and valve. Place the removed valves and other parts in order by each cylinder.
  - e. A valve spring seat of 2mm thick for each spring is fitted on the cylinder head surface. Be careful not to lose the spring seats.

**INSPECTION**

**Cylinder Head**

**NOTE:** See *SERVICE STANDARDS* for tolerances and measurements.

1. Before cleaning the cylinder head, check it for cracks, damage and water leaks.
2. Hot tank the cylinder head to thoroughly clean all surfaces and oil passages.

3. Check the lower surface of the cylinder head for distortion using a straight edge and a feeler gauge.

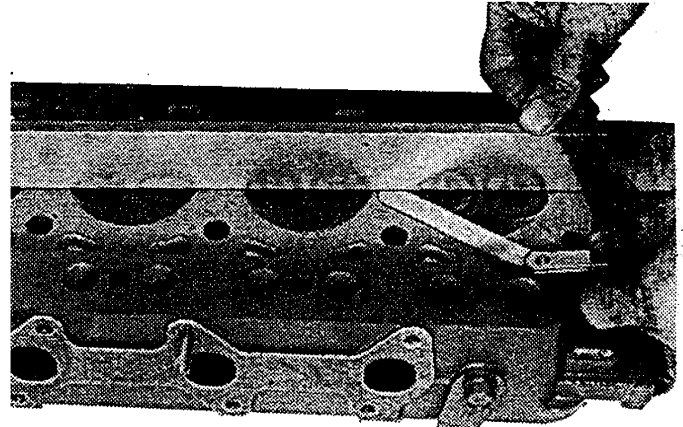

**CHECKING CYLINDER HEAD DISTORTION**

**Valve Guide**

1. Check the valve stem to guide clearance. If the replacement value is reached, replace the valve guide and valve.
2. To remove an existing guide, press it upward with a driver from under the cylinder head. To install a new guide, press it into the top of the cylinder head with a driver until the specified height is obtained.

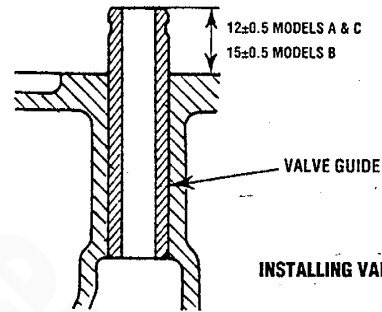

**INSTALLING VALVE GUIDE**

**Valve Seat**

1. Check each valve seat for damage and improper contact. If necessary, correct it as shown in the illustration. After correction, lap the valve into the seat using lapping compound.

**NOTE:** Correction of a valve seat should be done after the valve guide has been checked and if necessary, replaced.

2. If the valve seat sinkage reaches the replacement value (see *SERVICE STANDARDS*), install a new valve seat.

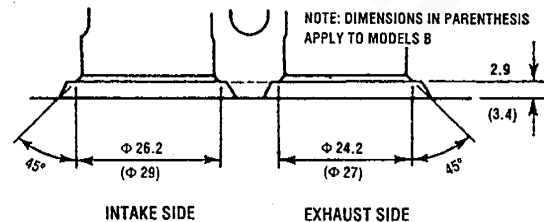

**CORRECTING VALVE SEAT**





3. Check the valve seat sinkage by measuring the installed length of each valve assembly. When measuring the size up to the top of the valve spring retainer, include retainer thickness (at the collar) of  $1.7 \pm 0.3$  mm.

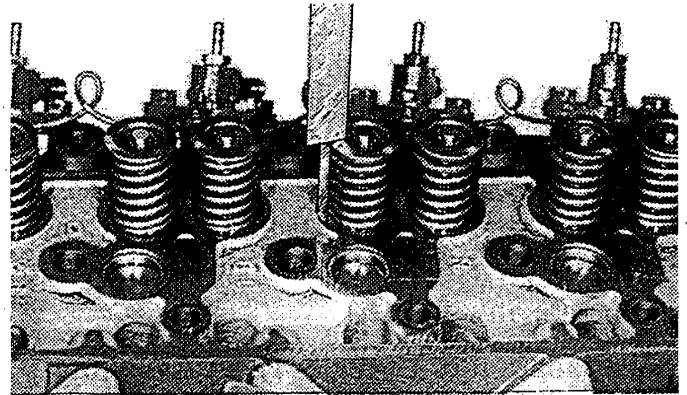
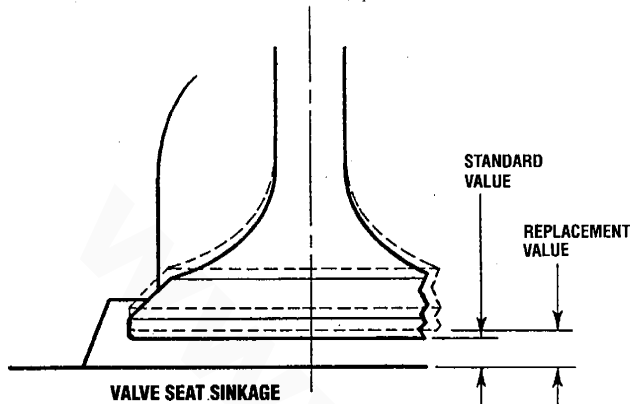

CHECKING INSTALLED LENGTH OF VALVE SPRING

**NOTE:** The thickness of the valve spring retainer collar is  $1.7 \pm 0.3$ .

4. Check the valve seat inserts if provided, for proper fit. Replace any that fit loosely.

### Valve

1. Check the valve face and stem for excessive wear, damage and distortion. If there is any, correct or replace the valve.
2. If the replacement value of the valve head thickness is reached, replace the valve.
3. Check each valve stem for wear and pitting in the areas shown by the arrows in the illustration. If necessary, correct or replace the valve.

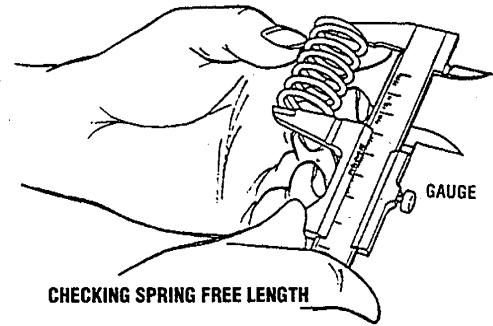

CHECKING SPRING FREE LENGTH

3. Check the squareness of each spring. Replace the spring if it tilts excessively.

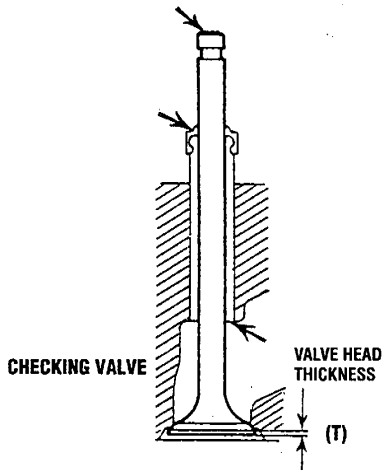

CHECKING VALVE

VALVE HEAD THICKNESS (T)



CHECKING SPRING SQUARENESS

### Valve Spring

1. Check the valve springs for cracks and damage.
2. Measure the free length and load of each spring. Replace the spring if excessively deteriorated.

### Rocker Arm and Rocker Shaft

1. Check the valve contact surface of each rocker arm for excessive wear and damage. If there is any, replace the rocker arm. Check the push rod contact surface of each adjusting screw for wear and damage. If there is any, replace the screw.
2. Measure the rocker arm I.D. and shaft O.D. If the difference between them is excessive, replace the rocker arm.

### REASSEMBLY

To reassemble the cylinder head, reverse the order of disassembly, taking care to observe the following instructions.

**Partial Reassembly**

1. Press in the valve guides to the specified height. (For the installation procedure, see *Valve Guide*.)
2. Install the valve stem seals securely on the valve guide.
3. Apply oil to the valve stems and insert them into the valve guides. Install the springs, retainers and retainer locks in that order.
4. To assemble the rocker arms and shaft, place the rocker shaft in such a manner that the identification mark ( $\phi 3$  mm hole) at the front end of the shaft faces toward the front of the engine. Install the front-most rocker arm and retain it with a snap ring. In a similar manner, install the other rocker arms, one after another. Finally, install the rear-most rocker arm and retain it with a snap ring. Then install the assembly on the cylinder head. When tightening the front and rear stays, be sure to install the bolt seats and washers.

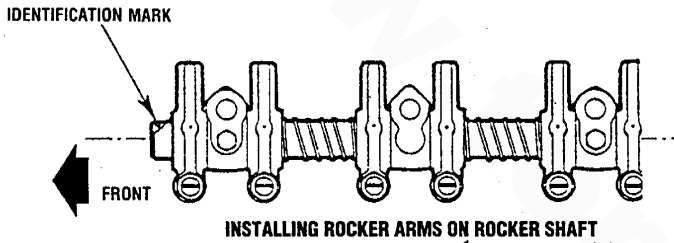

5. Tighten the glow plugs to the specified torque.
6. Install the nozzle holders and tighten the bolts temporarily. After installing the high pressure injection lines, retighten the bolts evenly to the specified torque. Do not reuse any sealing washers.
7. Install the glow plug lead wires. (The glow plugs are a taper sealed type; they do not require gaskets.)

**Installation of Cylinder Head Assembly**

1. Install the cylinder head assembly with a new gasket. The gasket does not require any sealant.
2. Tighten the cylinder head bolts to the specified torque in the numerical order shown in the illustration. Start with a slight torquing of the bolts, and after two or three stages of moderate torquing, finally tighten to the specified torque (see *TECHNICAL DATA*). (Be sure to use a torque wrench.)

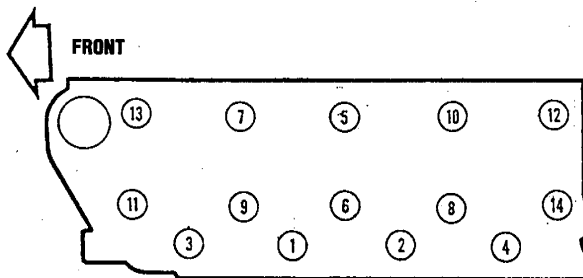

**CYLINDER HEAD BOLT TIGHTENING SEQUENCE**  
 (See Engine Adjustment section)

3. Be sure to use only new gaskets and packings. Apply sealant to the specified sealing points.

**Valve Clearance Adjustment**

Position the piston in #1 cylinder at the top of its compression stroke. Observe the valves and timing mark on the front crankshaft pulley (T.D.C.) when doing this. Adjust the valve clearances for cylinder #1. Rotate the crankshaft 90° in the normal direction of rotation (clockwise) and adjust the valves for the next cylinder in the engine's firing order, cylinder #3. Rotate the crankshaft another 90° and adjust the valves for cylinder #2.

**NOTE:** For additional information, see Adjusting Valve Clearance under *ENGINE ADJUSTMENTS*.

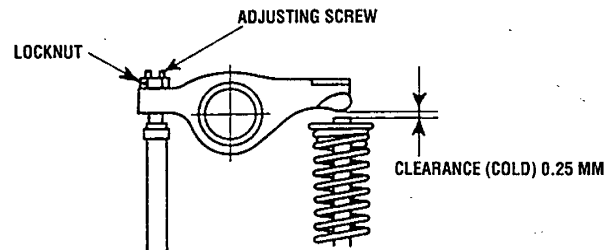

**ADJUSTING VALVE CLEARANCE**

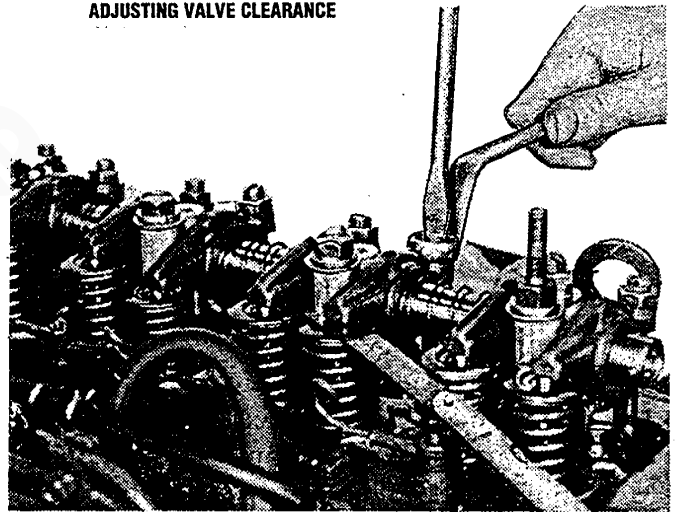

**CONSTRUCTION**

*The special iron casting cylinder block* is of a full jacket type in which cylinder liners are integrated with the cylinder block.

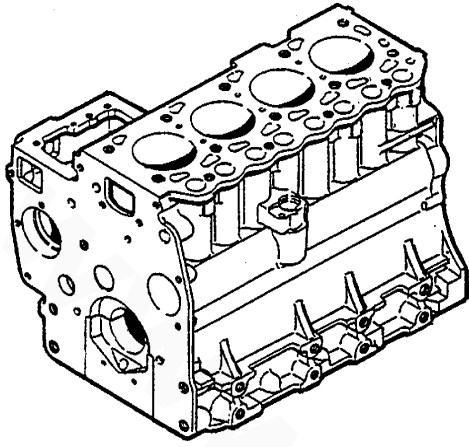

**CYLINDER BLOCK**

*The main bearings* are made of metal-backed copper sintered alloy (Kelmet) and an aluminum alloy. To improve run-in characteristics, they are coated with a lead-tin alloy plating on the journal surface, and tin flash-plating on the journal surface and tin flash-plating over the entire bearing surface. Crankshaft thrust is received by the flanged center bearing. On the front bearing area of the camshaft, a metal-backed special copper alloy rolled bushing is pressfitted.

*The crankshaft* is a precision-forging of carbon steel, which is supported by five bearings to provide high rigidity. Journals, pins and oil seal contact areas are induction-hardened to improve wear resistance and durability.



**CRANKSHAFT**

*The flywheel* is made of cast iron, and the ring gear is made of carbon steel and is shrinkage-fitted to the flywheel. The gear teeth are induction-hardened.

*The pistons* are made of an aluminum alloy to reduce engine weight and to decrease bearing load during high-speed operation. Each piston forms a tapered cylinder with elliptical cross section contour so as to obtain the best contact with the cylinder bore. The piston crown surface has a cavity to improve fuel combustion.

*The piston pins* are hollow, carbonized forgings. When connecting a piston to its rod, a piston pin is press-fitted into the small end of the rod.

*The piston rings* are made of special cast iron. Each piston is provided with three compression rings and one oil ring. The outside surfaces of the top compression rings and oil rings are hard chrome plated. The top rings are of the semi-key-stone type and the oil rings are provided with a coil expander.

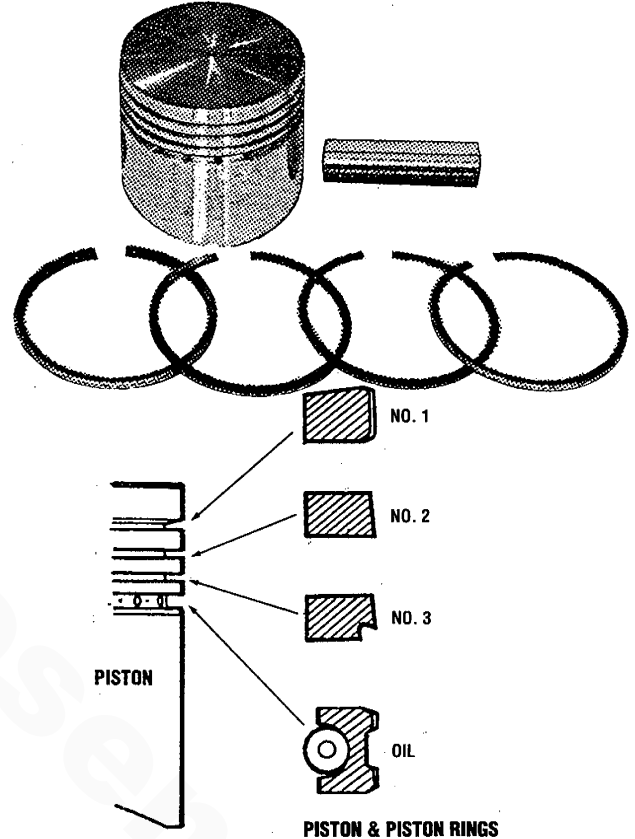

**PISTON & PISTON RINGS**

*The connecting rod* has an I-beam cross section and a horizontally split big end to provide high rigidity.

*The big end bearing* is made of a metal-backed special copper alloy and is flash-plated all over.

*The front plate and gear case.* The steel front plate is positioned by a dowel pin located in the upper part of the camshaft area and a dowel pin in the lower part of the injection pump area. It is bolted to the cylinder block through a gasket. On the left end rear surface, the lube oil pump gear bearing housing is installed together with the gear case. The aluminum casting gear case is attached to the front end surface of the cylinder block through the front plate. The case houses the lube oil pump front bearing and the governor related parts. It serves also as a camshaft and idler gear thrust stopper.

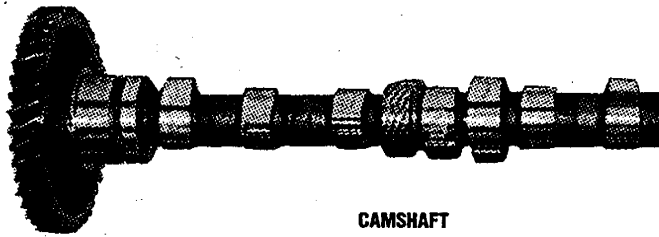

CAMSHAFT

**The Camshaft and Timing Gears.** The camshaft is a high carbon steel forging. The cam surface and journals are induction hardened to improve wear resistance. The shaft is supported on three bearings: the front bearing is a bush bearing (with the exception of a bushless bearing for engines produced in the initial period of production), while the middle and rear bearings are in the holes cut in the cylinder block. All bearings are lubricated by a forced lubrication system. The camshaft rear journal has a slot for intermittently lubricating the rocker arms through the cylinder head. The rear of the shaft is provided with an oil escape hole to let excess oil return to the oil pan.

The helical timing gears are finished by shaving and crowning to provide high durability and to reduce chattering. Valve timing is as follows.

**VALVE TIMING**

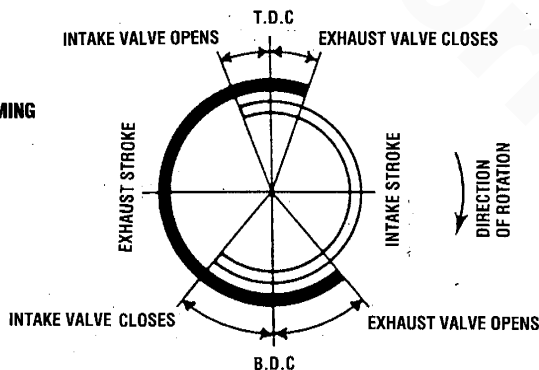

VALVE TIMING	
Intake valve opens (BTDC)	18°
Exhaust valve closes (ATDC)	18°
Intake valve closes (ABDC)	46°
Exhaust valve opens (BBDC)	46°

**The tappet and push rod.** The tubular type tappets are chill-hardened at the bottom and gas-carburized at low temperature over the entire surface to improve wear resistance. Each tappet is offset from the cam center to prevent uneven wear of the tappet bottom. The steel-bar push rods are flame-hardened at each end.

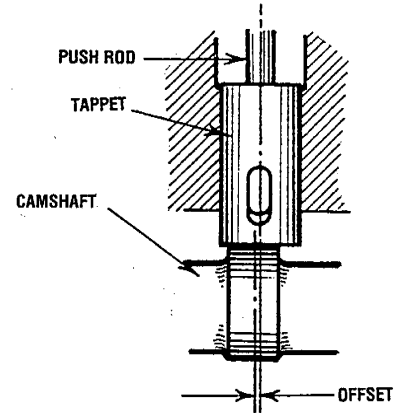

OFFSET OF TAPPET AND CAMSHAFT

**The injection pump camshaft** is made of high carbon steel. Its cam surfaces are induction-hardened to improve wear resistance. The front end of the shaft supported on a ball bearing is connected to a gear. The rear end is provided with an Oldham's coupling groove for connecting to the oil pump drive shaft.

**The high-pressure oil pump** is directly coupled to the injection pump camshaft at the rear of the shaft, mating into the Oldham's coupling groove.

**The sheet metal oil sump** has an oil drain hose that routes from the lube oil drain plug to a bracket at the front side of the engine.

## DISASSEMBLY

1. For removal of a the cylinder head and related parts, refer to *DISASSEMBLY* under *CYLINDER HEAD SERVICE*.
2. For removal of the water pump and electrical equipment, refer to their respective sections.
3. Pull off the push rods, then pull out the tappets upward.
4. Remove the fuel filter.
5. Loosen the crankshaft pulley nut, then take off the pulley and washer.
6. Loosen the flywheel mounting bolts and remove the flywheel.
7. Remove the back plate and rear oil seal case.
8. Remove the lube oil pump gear bearing housing. Remove the gear case, but first it is necessary to remove the tie-rod located at the right front (beside the injection pump) of the cylinder block and to remove the stopper spring and tie-rod from the injection pump's fuel rack.

**CAUTION:** Be sure to separate the injection pump rack from the tie-rod before removing the gear case. The front plate is bolted to the cylinder block from inside the gear case; therefore, be careful not to drive out the gear case together with the front plate. Also, be careful not to damage the dowel pins.

9. Remove the fuel injection pump.
10. Remove the governor weight bolts. Remove the weights.
11. Remove the pump camshaft bolt.
12. Remove the oil filter and the oil pump assembly. Then pull out the injection pump camshaft.
13. Remove the gears. Then remove the front plate.
14. Remove the camshaft.
15. Turn the engine upside down. Remove the oil pan and oil screen.
16. Remove the nuts from the big end of each connecting rod and remove the cap. Push the piston and connecting rod assembly upward out of the cylinder block. Keep the removed parts in order for each cylinder. When pushing out the piston and connecting rod assembly, put a wooden block against the cap mating surface of the rod so as not to damage the metal surface.
17. When separating the piston from the connecting rod, use the following procedures. Keep the disassembled parts in order for each set. Take care to prevent confusion, especially for each set of piston and wrist pin.
  - a. Set the piston and connecting rod assembly on the special tool (piston pin setting tool) body.
  - b. Insert the push rod of the tool into the piston pin hole and press the pin out.

**CAUTION:** Do not hammer a piston pin to remove it. A stuck piston pin which requires excessive pulling force should be replaced. Do not apply a load of more than 3,000 kg to the piston pin setting tool.

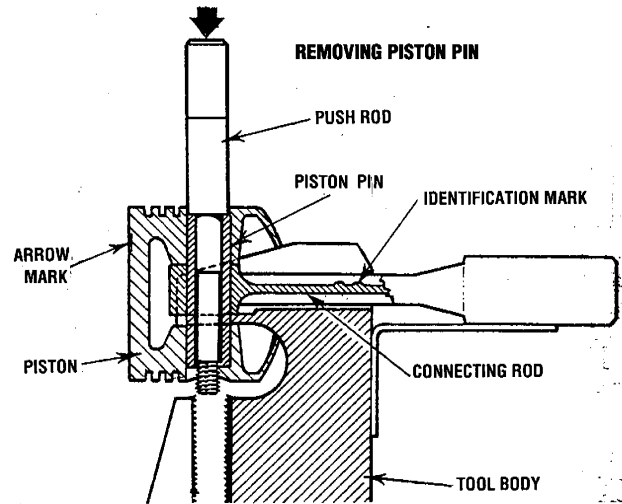

18. Remove the main bearing caps. Keep the caps and bearings in order for each cylinder. It is necessary to measure the crankshaft end play before removing the caps (see *Crankshaft*, para. 3., under *CYLINDER BLOCK SERVICE*). Mark the caps and rod with a number punch 1 – 4 as needed.
19. Remove the crankshaft.

## INSPECTION

### Cylinder Block

1. Check the cylinder block for cracks and damage. If there is any, repair or replace the block. Check the camshaft front journal bushing for wear and damage. If there is any, replace the bushing using a special tool (Tool #033583).

**CAUTION:** The camshaft bushing is a forced fit in the cylinder block. The camshaft bushing will be crushed or damaged when removed. Take care not to burn or scratch the bushing boss in the block, as this will interfere with the installation of the new bushing.

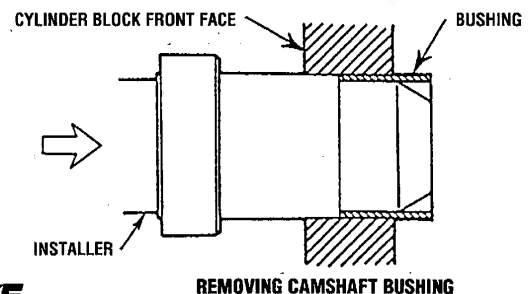

2. Check the water jacket for scale and corrosion. Clean the block thoroughly and ensure that all oil passages are clean.
3. Check the cylinder walls for scratches, dents and wear. If necessary, repair by honing or boring. Measure the cylinder bore in right-angled directions A and B at three different depths.

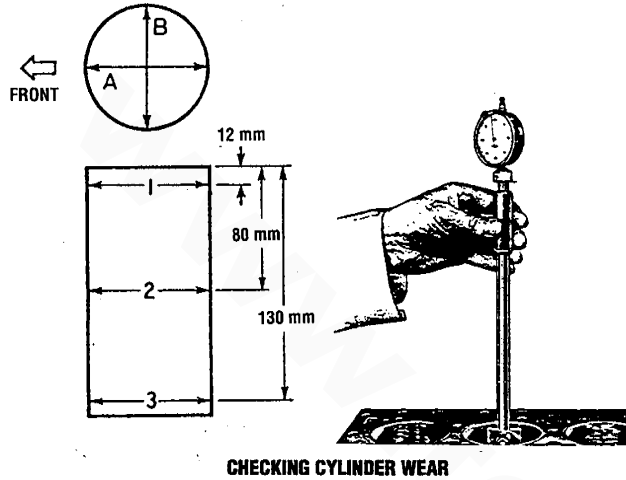

3. Measure the side clearance between each piston ring and its groove. If necessary, replace the ring.

As to the semi-keystone type top ring, allow it to sink by its own weight into the groove, then measure its depth from the piston surface.

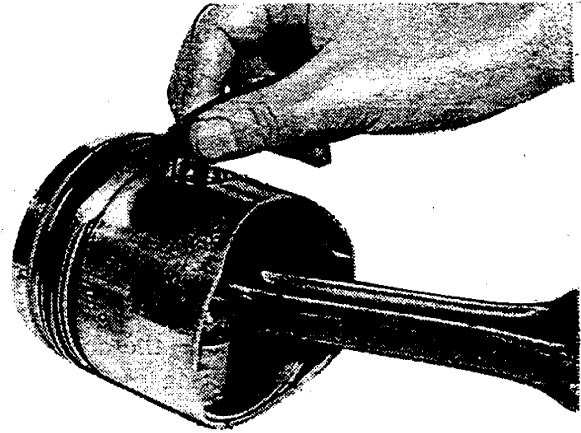

**PISTON RING SIDE CLEARANCE**

4. When cylinder bore wear is not excessive and only the piston rings require replacement, check the upper part of the cylinder for ridge wear. If any exists, ream the cylinder bore and hone when necessary.

**Piston, Piston Pin and Piston Rings**

1. Check the piston for seizing, scratches and wear. If necessary, replace the piston.
2. Measure the piston O.D. Replace the piston if excessively worn. If the piston-to-cylinder clearance is excessively large, machine the cylinder to an oversize bore or replace the piston. The piston O.D. should be measured at the lower end of the skirt at right angles to the axis of the piston pin hole.

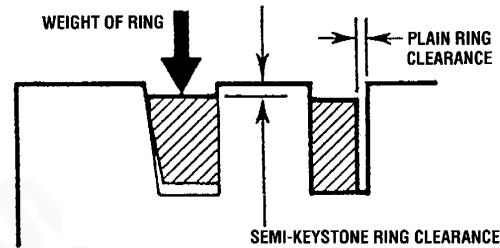

4. Measure the gap of each piston ring. Replace the ring if its gap is excessively large. To measure the ring gap, insert a ring into the least worn place of the cylinder bore (skirt) using a piston and measure the gap with a feeler gauge.

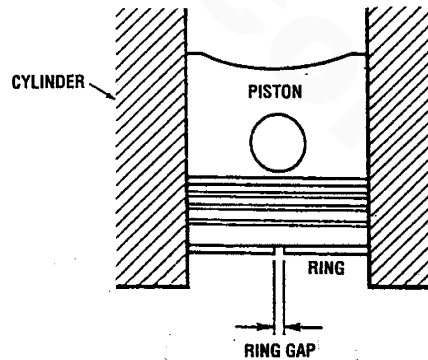
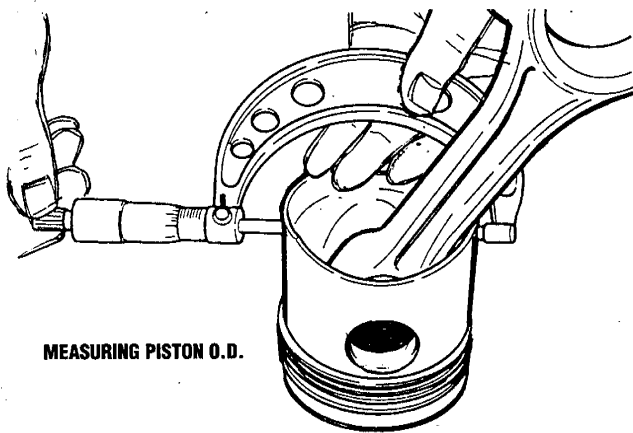

### Connecting Rod

1. Using a connecting rod aligner, check each connecting rod for bending and distortion. If necessary, correct or replace the rod.
2. Measure the connecting rod thrust clearance with a rod assembled on the crankshaft. If the clearance is excessive, replace the rod assembly.

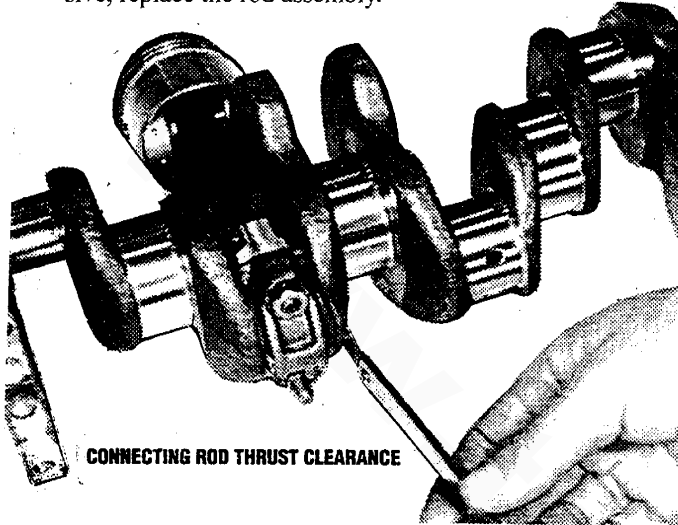

CONNECTING ROD THRUST CLEARANCE

### Crankshaft

1. Measure the crankshaft bend. If excessive, repair or replace the crankshaft.

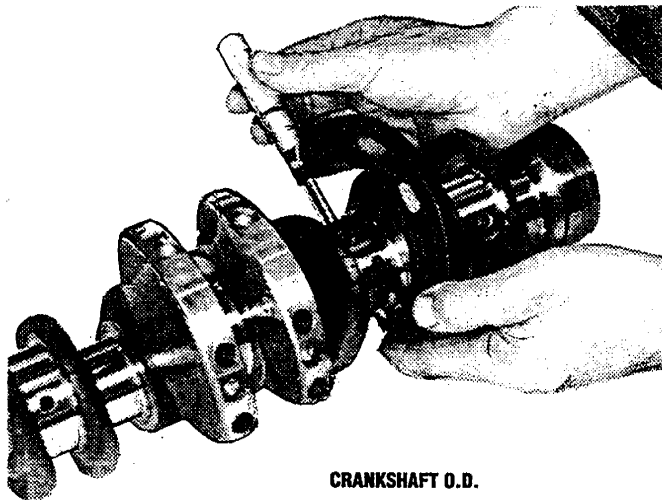

CRANKSHAFT O.D.

2. Check the crankshaft journals and pins for damage, seizure and other faults. If excessively worn or damaged, machine to the undersize diameter. At the same time, replace the corresponding main bearing or connecting rod bearing with the same undersize bearing. When machining a crankshaft journal or pin to the undersize one, be sure to finish its fillets to R2.5 mm. Check that all oil passages in the crankshaft are clean and open.

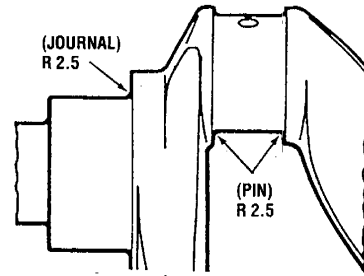

3. Check the crankshaft end play. If the specified limit is exceeded, replace the flanged No. 3 main bearing. To check the end play, install the main bearings, crankshaft and main bearing caps, then tighten the cap bolts to the specified torque. Measure the end play with a dial gauge held against the front end of the crankshaft.

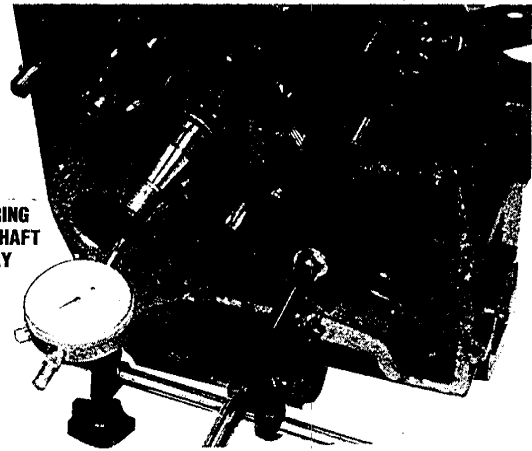

MEASURING CRANKSHAFT END PLAY

### Main Bearings and Connecting Rod Bearings

Check the surface of each bearing for flaking, melting, seizing and poor contact. If any of these conditions exist, replace the bearing.

Fit the main bearings to the cylinder block and the connecting rod bearings to the connecting rods. Tighten the bolts to specification. Measure the I.D. of each bearing. Then measure the O.D. of the crankshaft journals and pins to calculate the oil clearance (a plastigauge may be used). If any oil clearance is excessive, replace the corresponding bearing. If an excessive clearance still remains even after replacement of the bearing, grind the crankshaft to the undersize O.D. and install the same undersize bearing.

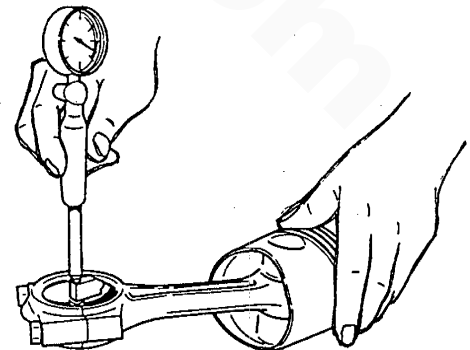

MEASURING CONNECTING ROD BEARING I.D.

### Gearcase

Check the gearcase body for cracks and damage, and the oil seal for damage. Also check the governor related parts. If the camshaft thrust plug press-fitted in the gearcase has been worn or damaged, install a new thrust plug.

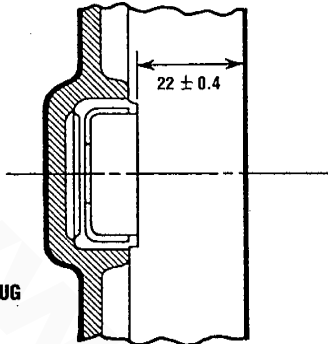

PRESS-FIT HEIGHT OF CAMSHAFT THRUST PLUG

### Timing Gears and Lube Oil Pump Gear

Check each gear for poor contact, wear and damage. If there is any, replace the gear. Also check the splined bore of the lube oil pump gear for faults.

### Camshaft

Measure the clearance between the center journal and the cylinder block, and between the rear journal and the cylinder block. If either or both clearances are excessive, replace the camshaft, front bushing or cylinder block. Replace the camshaft if the cam surface is damaged or the cam lobe is badly worn.

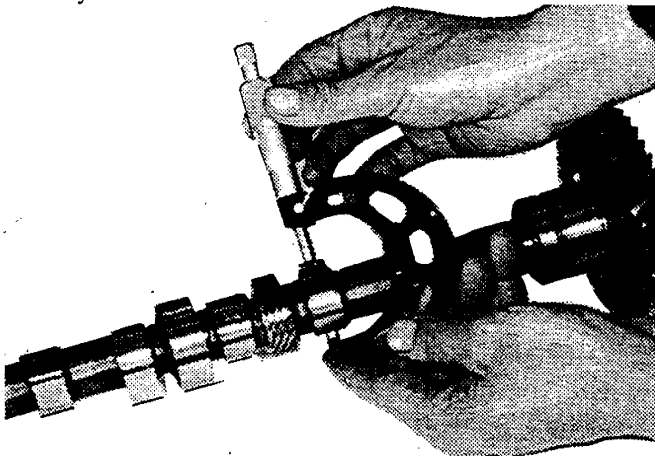

MEASURING CAM LOBE HEIGHT

### Fuel Injection Pump Camshaft

Replace the camshaft if the cam surface is excessively worn or damaged or if the Oldham's coupling is damaged.

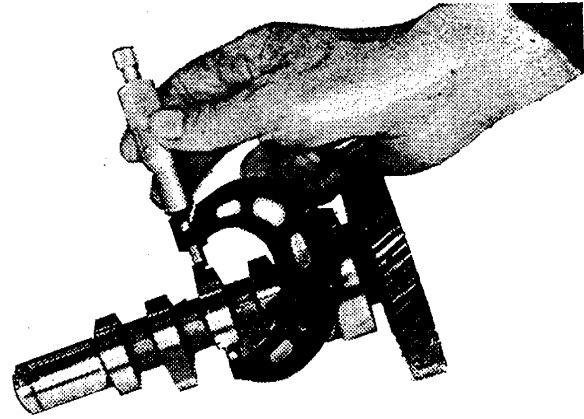

MEASURING INJECTION PUMP CAMSHAFT LOBE

### Ball Bearings

Check each ball bearing for excessive wear or damage and for irregular or noisy rotation. If there is any, replace the bearing.

### Tappets

1. Check the bottom of each tappet for cracks, flaking and nicks. If any of these conditions exist, replace the tappet.
2. Check the clearance between each tappet and the cylinder block. If any clearance exceeds the specified limit, replace the tappet.

### Push Rods

1. Replace a push rod if both its ends are excessively worn.
2. Place each push rod on a surface plate and check for bending at the center of the rod. If the bend exceeds the specified limit, correct or replace the rod.

### REASSEMBLY

**CAUTION:** Clean each part sufficiently. Clean oil passages, sliding surfaces and rotating parts with special care.

Before assembling, apply engine oil to all sliding, rotating and press fit parts such as bearings and cylinder inner walls.

Replace gaskets, packings and oil seals with new ones. Apply sealant to gaskets and packings, and to the specified sealing points.

Observe tightening torque and sequence where specified. For other parts, tighten to the torque for ordinary screws or bolts as the torque table specifies. Check clearances and end plays during assembly work.



1. When the camshaft front bushing is pressed in, align the bushing oil hole with the oil hole in the cylinder block using a bushing installing tool. For proper alignment, make a mark indicating the block's oil hole position on the front end face of the block. After installing the bushing, confirm that the oil holes are properly aligned with each other.

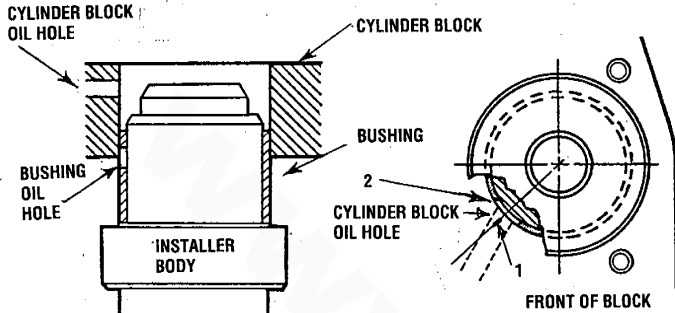

1. DRAW A MARK AT OIL HOLE CENTER OF BLOCK (BEFORE INSTALLING BUSHING).
2. ALIGN BUSHING OIL HOLE WITH BLOCK OIL HOLE, PRESS IN BUSHING.

2. When pressing in the idler gear shaft, follow the alignment and length of protrusion shown in the diagram. **Failure to do so will result in low oil pressure during engine operation.**

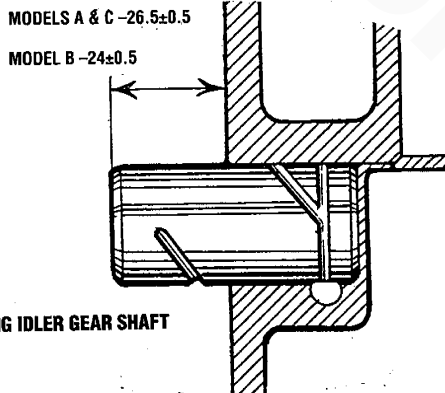

3. When replacing the dipstick guide, coat the new guide (without a flange) with **HERMESEAL 52B** sealant, then press-fit into the cylinder block. Press-fit to a height of  $30 \pm 0.5$  (1.1811"  $\pm$  0.0197") from the cylinder block surface. When installing the former type of guide, which is increased in diameter at the midpoint, press it in until caught in the hole. (There is no difference in the press-fit position between the former type and later type guides.)

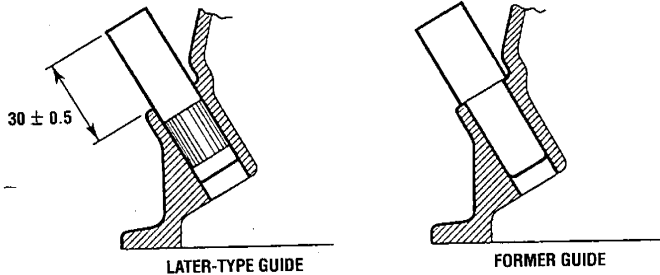

GUIDE INTO BLOCK



4. Install the main bearings to the cylinder block.  
**NOTE:** The oil ports must be properly positioned and the bearing fitted correctly into the block recess.
5. Install the crankshaft. Apply engine oil to the journals and pins.
6. Install the main bearing caps and tighten the cap bolts to the specified torque. Each cap carries an embossed arrow mark and numeral to prevent incorrect installation of the caps. When installing the No. 1 and No. 5 caps, apply sealant to the upper surface (cylinder block mating surface).

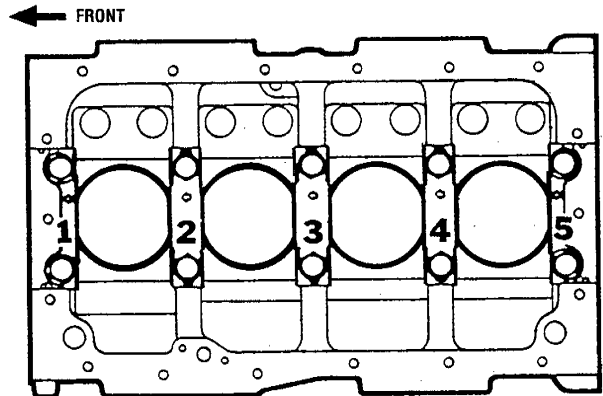

7. Check the crankshaft end play.
8. Apply sealant to the outside surface of both side seals. Press the side seals into the front and rear caps, thus completing the reassembly of the crankshaft.

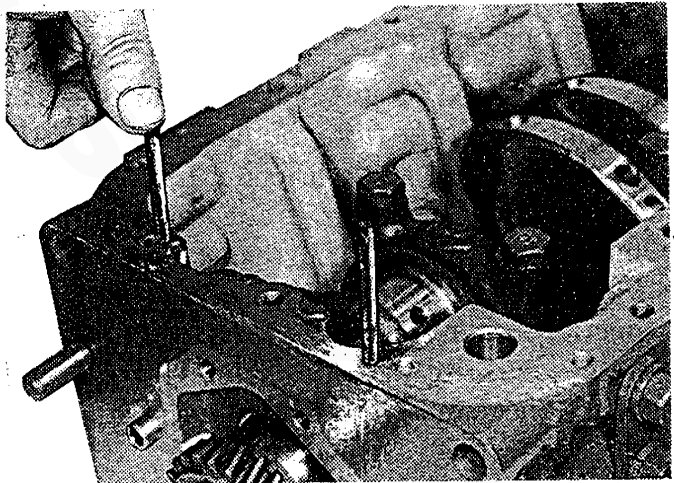

INSTALLING BEARING CAP SIDE SEALS

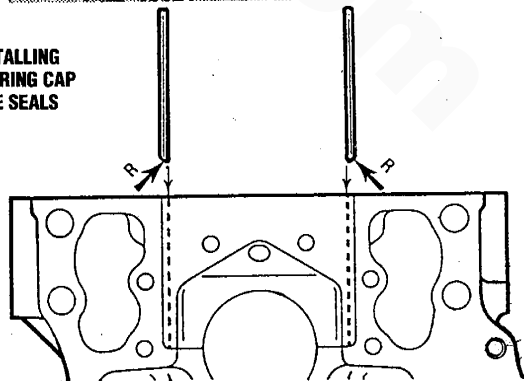

9. Install the oil seal into the crankshaft rear oil seal case. Install the seal case to the cylinder block. Remember to install the gasket. Turn the crankshaft one complete revolution to ensure there is no unwanted binding.
10. Install the back plate.
11. Install the flywheel. The bolts should be tightened to the specified torque.
12. Assemble the piston and the connecting rod using the Piston Pin Setting Tool.

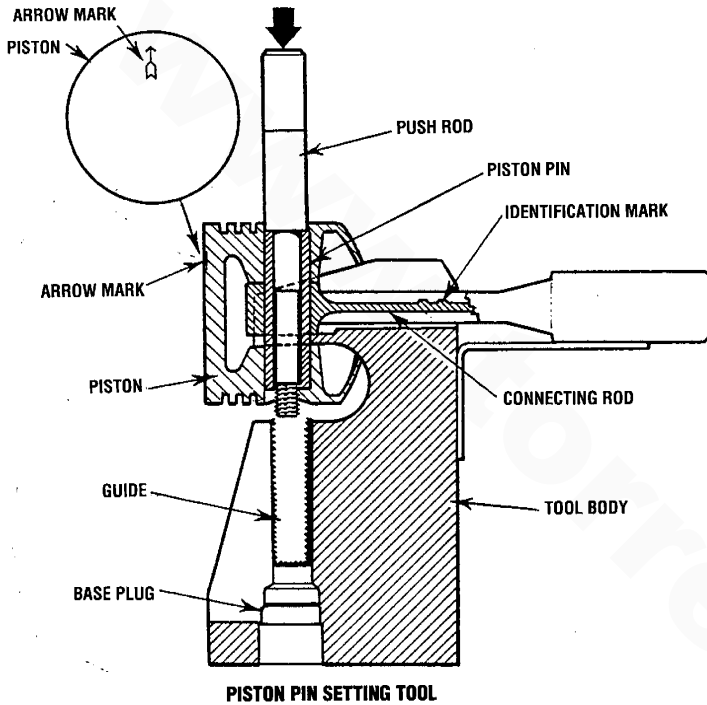

- a. Insert a piston pin into the push rod of the tool, then screw a guide (see illustration for proper guide) fully into the push rod.

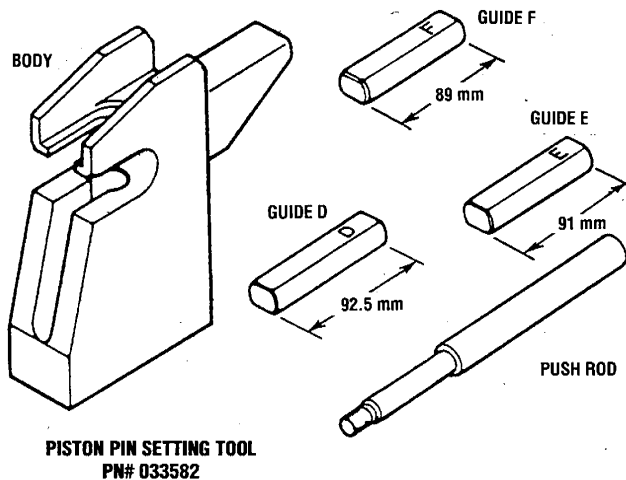

- b. Insert the assembled push rod, piston pin and guide into the piston pin hole from the guide side, and into the small end of the connecting rod. In this case, both the arrow (front mark) on the piston head and the identification mark on the connecting rod are to be positioned upward. Before insertion, apply engine oil to the piston pin and to the connecting rod small end hole.
- c. Set the piston, connecting rod and guide as an assembly on the tool body. When setting, insert the tool guide into the tool body with the cut in the guide in alignment with that in the tool body and then turn the guide 90°. Make certain the small end of the connecting rod rests properly on the tool body. Also, confirm that the front mark on the piston head and identification mark on the connecting rod face up.
- d. Press the piston pin in under a pressure of 500 to 1500 kg. If the piston pin is easily pressed in with less pressure than above, or if the pin needs a greater pressure, replace the connecting rod or the piston and pin assembly. The piston pin will be positioned in place by the guide. After installation, turn the push rod 90° so that the cut in the guide comes in alignment with the cut in the tool body. Detach the piston and connecting rod assembly from the tool body.

**CAUTION:** After assembling the piston and connecting rod, make certain the connecting rod small end is properly positioned at the center of the piston pin. If any excessive deviation from the proper position is found, correct it. In this case, check the piston pin setting tool also.

*Each piston and its pin are matched parts and, therefore, a set of piston and pin must not be confused with other pistons and pins. All pistons and pins to be used in an engine must be of the same size (same mark).*

13. Piston rings differ in shape from one another. Be sure to install them in their proper positions and directions, as illustrated, and with the stamped manufacturer mark and size mark facing up. When installing the piston ring with a coil expander, position the expander joint opposite to the ring-gap position.

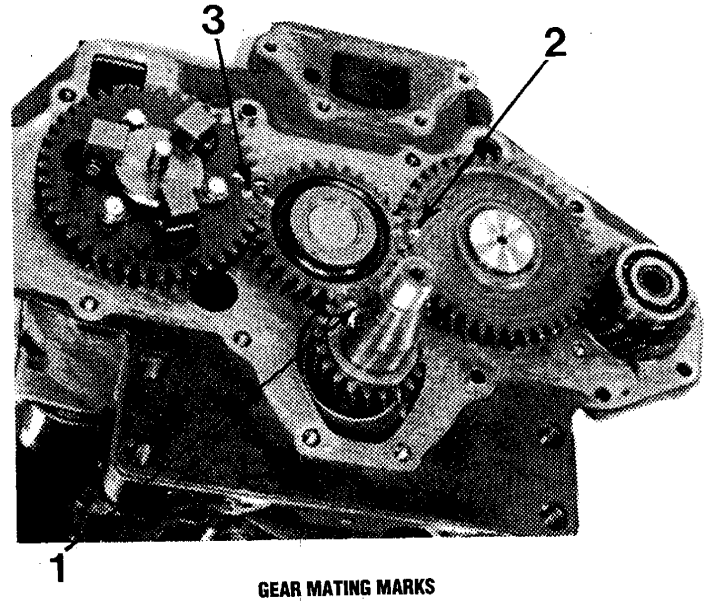
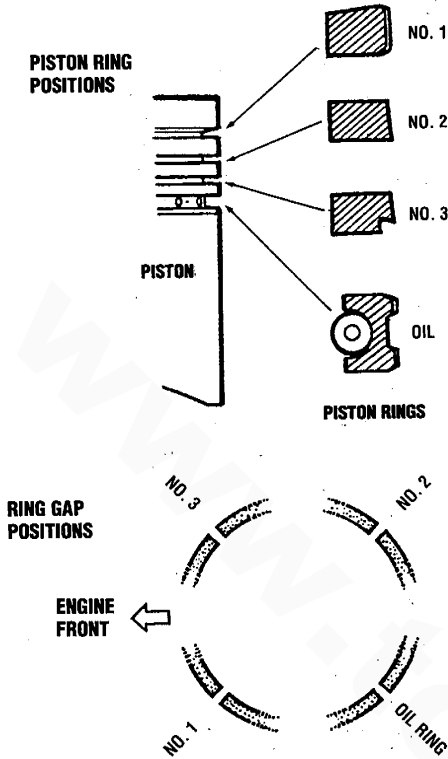

14. Install the piston and connecting rod assembly from the top of the cylinder block using a ring band. In this case, make certain the piston ring gaps are properly positioned and the arrow mark on the piston faces the front of the engine. After insertion, install the connecting rod end halves in place and tighten the rod cap bolts to the specified torque. Apply oil to the bearing surfaces before assembly of the connecting rod ends.
15. Install the front plate. Remember to install the gasket and dowel pin.
16. Turn the crankshaft until the No. 1 cylinder piston comes to the top dead center.
17. Align the keyway in the crankshaft gear with the key on the crankshaft. Install the gear on the shaft.

18. Align the mating mark "1" on the idler gear with that on the crankshaft gear; install the idler gear on the idler shaft. Insert the camshaft and gear assembly into the cylinder block so that the mating mark "2" on the camshaft gear aligns with that on the idler gear. Then insert the injection pump camshaft assembly into the cylinder block and align the mating mark "3" on the pump gear with that on the idler gear. Finally, install the injection pump drive shaft gear assembly.
19. Confirm that mating marks on the gears are in proper alignment with each other.
20. Fit the governor weight assembly to the injection pump cam gear.
21. Install the gear case (with the governor and related parts previously installed) and gasket. When installing the gear case, insert the tie-rod and tie-rod stopper spring into the hole in the cylinder block so to position it next to the injection pump fuel rack.

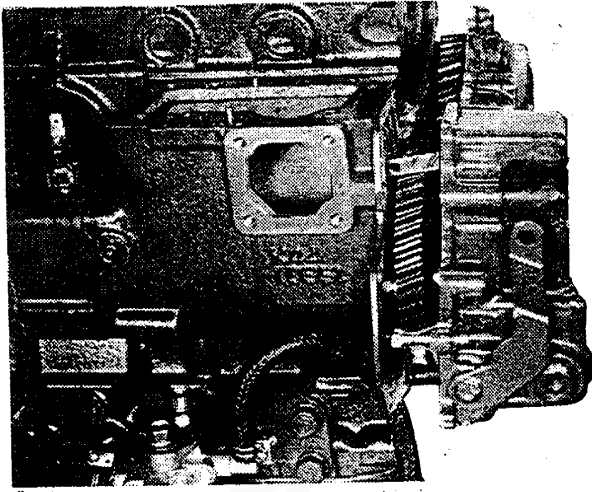

**INSTALLING GEAR CASE**

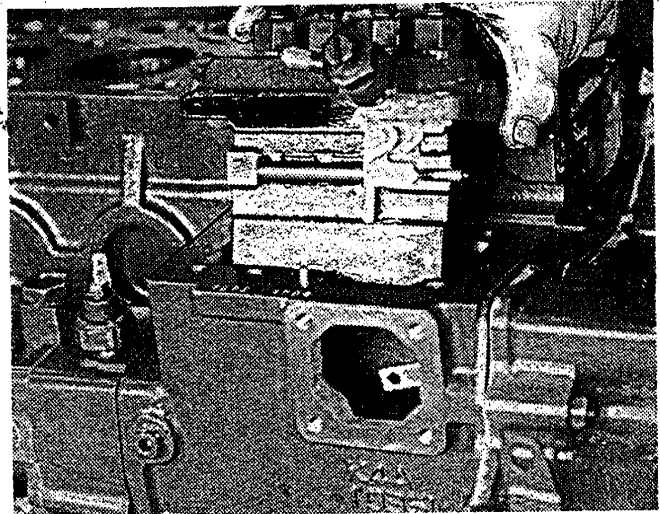

**INSTALLING INJECTION PUMP**

22. Insert the crankshaft pulley. Install the washer and nut. Then tighten to the specified torque.
23. Install the back plate. Be sure to install the gasket.
24. Install the oil pick up, then install the oil pan.
25. Apply oil to the periphery of the tappet. Insert the tappet into the cylinder block. Then insert the push rod properly into the tappet hole. Check to see if the tappet moves lightly.

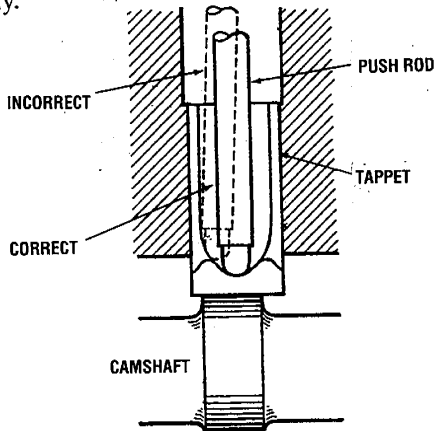

**INSTALLING TAPPET AND PUSH ROD**

28. Install the oil pump and oil filter (see *REASSEMBLY* under *LUBRICATION SYSTEM SERVICE*). When the oil pressure switch and oil pressure sender with adapter has not yet been installed, apply sealant to the threaded portion when installing.
29. Install the fuel filter.
30. Install the fresh water pump.
31. Install the starter (see *STARTER/SOLENOID SERVICE*) and alternator (see *ALTERNATOR/REGULATOR SERVICE*).
32. Install the raw water pump.

26. Install the cylinder head assembly (see *CYLINDER HEAD SERVICE, REASSEMBLY*).
27. Install the injection pump assembly (see *Installation and Adjustment of Fuel Injection Pump* under *FUEL SYSTEM*).

## DESCRIPTION

The governor keeps engine speed constant by using a balance between the centrifugal force acting on the governor weights and the tension of the governor spring.

If engine speed increases, the governor weights will open, forcing the sliding shaft forward. This moves the injection pump fuel rack, linked to the sliding shaft through the governor lever assembly, tie-rod and spring, in the direction that injects less fuel into the cylinders. The movement is stopped at a point where the centrifugal force of the governor weights balances with the tension of the governor spring.

If engine speed is decreased by an overload, the control rack is pushed against the smoke set spring in the direction that injects more fuel. The Angleich mechanism restricts the increase and quantity of fuel injection thus preventing overload, saving fuel, and decreasing exhaust smoke.

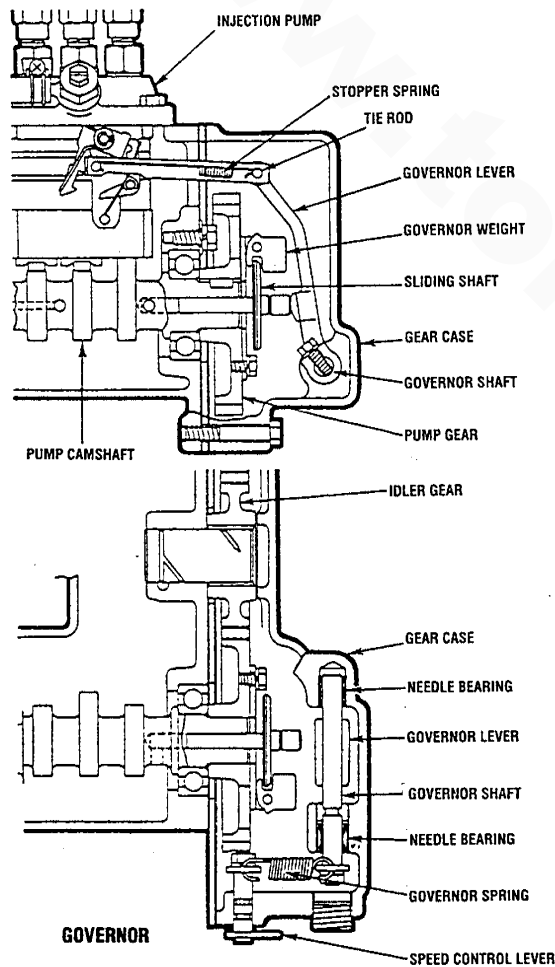

3. Remove the fuel injection pump (see *Fuel Injection Pump* under *FUEL SYSTEM*)
4. Remove the gear case mounting bolts and remove the gear case (see *CAUTION* under *DISASSEMBLY, CYLINDER BLOCK SERVICE*).
5. Remove the governor spring.
6. Remove the nut, washer, spring lever. Remove the speed control lever from the gear case.
7. Remove the nut, washer and spring lever, remove the governor lever set bolt, and remove the governor lever.
8. Remove the governor weight assembly and the sliding shaft from the injection pump camshaft.
9. Remove the tie-rod and spring from the governor lever.

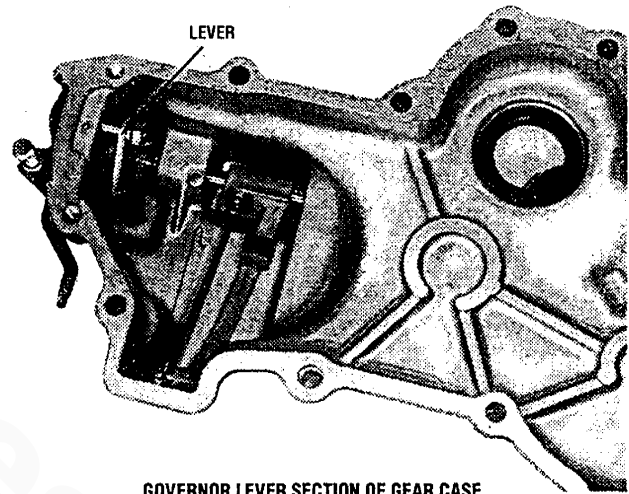

GOVERNOR LEVER SECTION OF GEAR CASE

## INSPECTION

1. Check the governor weights for wear and damage. Replace if defective.
2. Check the sliding shaft for damage and stiff movement. Replace if defective.

### Governor Lever

Check the sliding shaft contact area of the governor lever and check the tie-rod and spring which connect the governor lever to the fuel rack. Replace if defective.

### Governor Spring

Check the spring for deterioration and breakage. Replace if defective. When overhauling, replace the spring.

### Needle Bearing

Check the needle bearing supporting the governor lever shaft in the gear case for damage.

## REASSEMBLY AND ADJUSTMENT

To reassemble the governor, reverse the order of disassembly. After reassembly, check the governor for smooth operation.

## DISASSEMBLY

1. Remove the drive belt (see *FRESH WATER COOLING SERVICE*).
2. Remove the crankshaft pulley nut and remove the pulley.

**ENGINES WITH MANUAL STOP (Standard)**

A manual stop lever is located on the outboard side of the engine block just below the fuel injection pump. The damper spring is also mounted on this same lever assembly. A throttle bracket is provided to attach a push-pull cable. This cable is attached to the shutoff lever. When pulled fully in the stop direction by the cable, a lever inside the cover assembly moves the fuel rack of the injection pump to the fuel stop position, stopping the engine. Once the engine stops, the cable is pushed in to return the shutoff lever back into the fuel/run position. A heavy return spring on the shutoff lever assists in doing this. Periodically lubricate the lever and push-pull cable to ensure free movement.

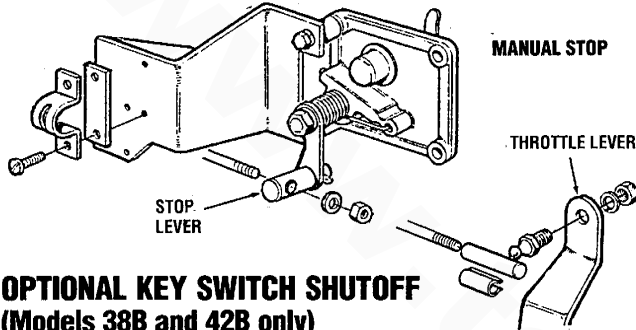

**OPTIONAL KEY SWITCH SHUTOFF (Models 38B and 42B only)**

An optional key switch shutoff solenoid #037100 is offered for the above two models only. This solenoid mounts in a boss directly behind and slightly below the injection pump mounting location. This solenoid, when energized by turning the key-switch on, allows the injection pump fuel rack to move to the fuel/run position allowing the engine to start to run. When the key switch is turned off, the solenoid plunger moves the fuel rack to the stop fuel position stopping the engine.

**Installing and Adjusting the Key Switch Shutoff Solenoid**

1. Remove the large plug or side oil filler assembly located just behind the injection pump and slightly below it on the engine block.
2. Visual access to the fuel injection pump fuel rack is needed. To obtain this, remove the shutoff lever side cover assembly.
3. Thread the locknut all the way onto the solenoid and apply a small amount of Teflon sealant to the threads forward of the nut.
4. Thread the solenoid into the boss on the engine block and observe the solenoid plunger through the side cover opening. Allow the plunger to contact the fuel rack and move it fully into the shutoff position on the injection pump. Do not thread the solenoid further into the boss so that the plunger against the fuel rack is pushed into the solenoid.
5. Back the solenoid out of the boss 1/4 to 1/2 turn and secure the solenoid in position with the locknut.
6. Properly connect the three electrical leads from the solenoid. The black eye lead goes to block ground. The white

pull-in lead should be run to the heavy solenoid terminal on the starter. Connect the red hold lead (splice into) the "R" connection on the DC alternator.

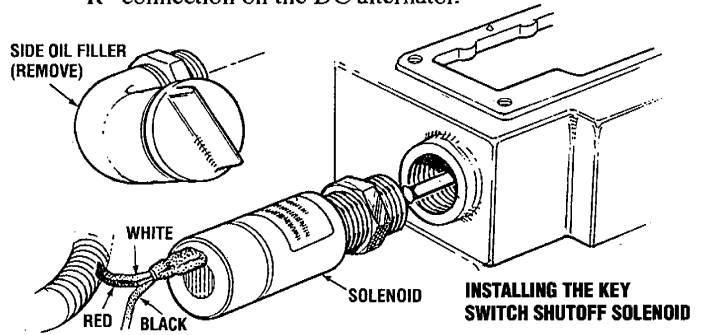

**Key-Stop Solenoid System Operation Checking Procedure.**

1. Wire the system making reference to the wiring diagram.
2. Viewing with the tie-rod cover off, confirm that when the key switch is turned to the ON position before starting the engine, the solenoid energizes and brings the fuel injection pump fuel rack to the MS STOP plate position.
3. Turn the key switch to OFF and reinstall the tie-rod cover.
4. The shutoff sequence is as follows:  
 When the start button is depressed during the normal starting procedure, the solenoid is energized by the pull-in lead. Once the engine starts and the start button is released, the solenoid remains energized by current to the hold lead of the solenoid coming from the "R" terminal connection on the alternator which receives voltage/current once the engine starts and the oil pressure switch closes from engine oil pressure.

**CAUTION:** The pull-in lead draws about 8-10 amps to energize the solenoid. The hold lead draws about one amp to keep the solenoid energized. Should these leads be connected incorrectly during installation the solenoid will be damaged from excess current draw during engine operation.

**NOTE:** Should the solenoid fail and engine operation is required, unscrew the solenoid as far out of the boss as possible without removing it. Lock it in position with the locknut. The engine will now start. To shut the engine off, use the manual shutoff lever. Disconnect the two leads red and white from their power source.

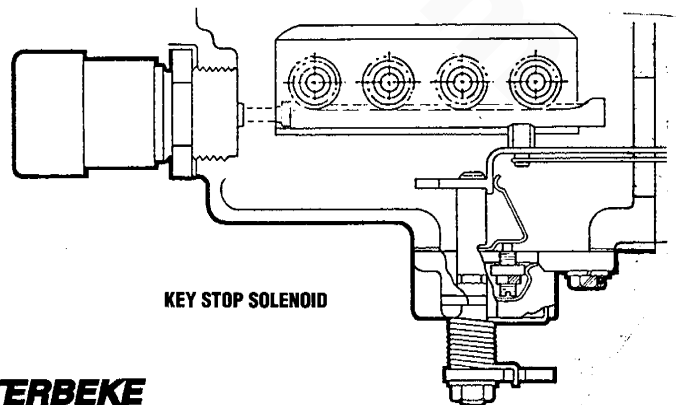

## ENGINE ADJUSTMENTS

### TIGHTENING THE CYLINDER HEAD

Pull off the air breather pipe from the rocker cover and remove the rocker cover. Before adjusting the valve clearance, retighten the cylinder head bolts to their specified torque in the sequence shown in the diagram. Make sure the engine is cold when this is done. Before applying the specified torque to a bolt, loosen it 1/4 to 1/2 a turn and then apply the torque (see *TECHNICAL DATA*).

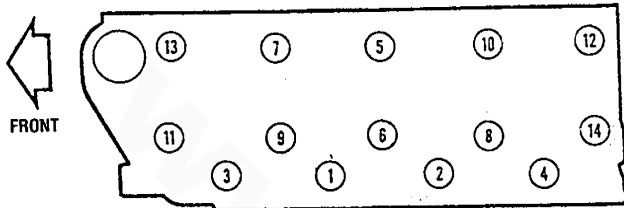

CYLINDER HEAD BOLT TIGHTENING SEQUENCE

### ADJUSTING VALVE CLEARANCE

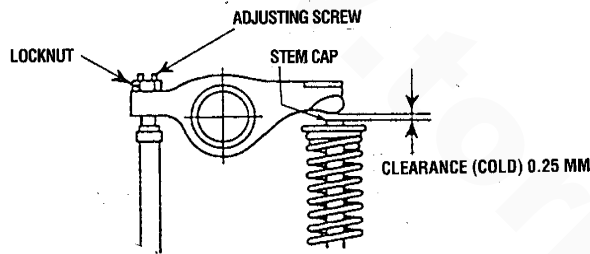

ADJUSTING VALVE CLEARANCE

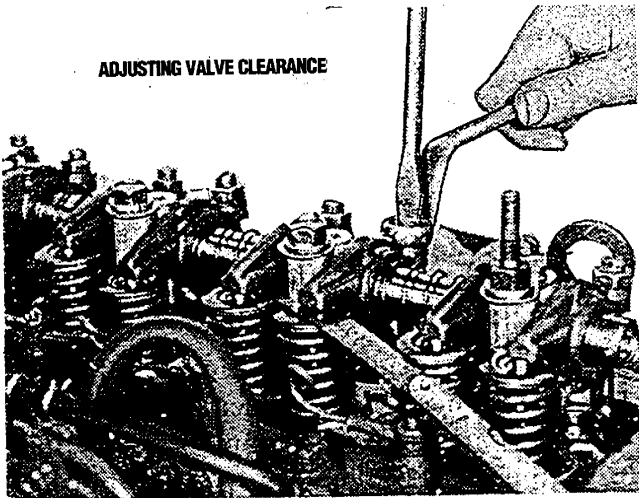

1. Adjust the valve clearances at TDC (Top Dead Center) for each cylinder when they are on their compression stroke. Remember the engine's firing order is 1-3-4-2.

The engine's valves must be adjusted in this order while the valves are closed. You may find that turning the engine's crankshaft is more easily accomplished when the engine's glow plugs are removed before the crankshaft is rotated.

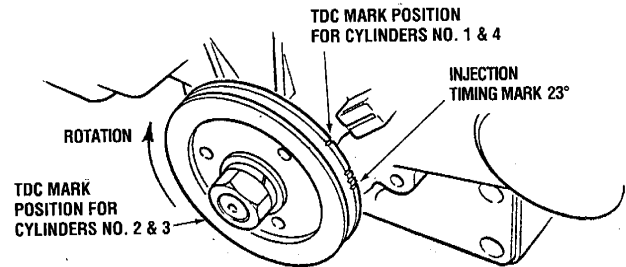

- a. Rotate the engine in the normal direction of rotation placing the No. 1 Cylinder at the top of its compression stroke. The TDC mark on the crankshaft pulley should be in line with the pointer on the front of the gear case cover, and the valves for the No. 1 cylinder should be closed. Now adjust the intake and exhaust valves for cylinder No. 1.
- b. After adjusting the valves for cylinder No. 1, rotate the front crankshaft pulley clockwise 180° so the TDC mark on the pulley is positioned approximately in the position shown in the illustration for cylinder No. 3. Now adjust the intake and exhaust valves for cylinder No. 3.
- c. Rotate the crankshaft pulley clockwise another 180° and adjust the valve clearances for the intake and exhaust valves for cylinder No. 4.
- d. Rotate the crankshaft pulley clockwise another 180° and adjust the valve clearances for the intake and exhaust valves for cylinder No. 2.

Adjust each valve's clearance by inserting a 0.25 mm (0.010") feeler gauge between the rocker arm and the valve stem as shown.

### ADJUSTING FUEL INJECTION TIMING

1. Position the number one piston at the beginning of its compression stroke. Remove the high pressure injector line from between the number one cylinder's injector and the injection pump. Remove the number one delivery valve holder. Remove the spring below it and reinstall the holder. Attach the high pressure injector line to the holder and have the other end pointing outboard of the engine. Open the throttle and energize the fuel lift pump. Fuel should flow out of this line. Have a container under it to catch the fuel. Slowly turn the crankshaft in the normal direction of rotation and watch the fuel flowing from the injector line. The instant it stops is the beginning of the injection point. Observe the timing mark on the front crankshaft pulley and the timing pointer on the front gear case. Refer to *SERVICE STANDARDS* for the injection timing for the model being checked.

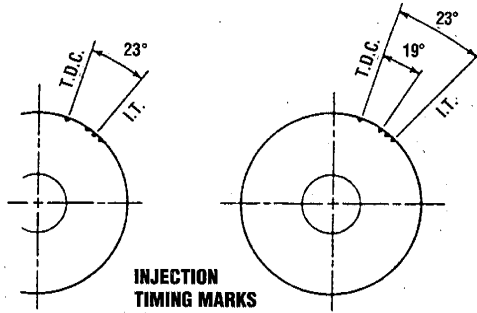

2. When the specified injection timing is not correct, increase or decrease the shim material thickness under the fuel injection pump. Injection timing varies 1° with 0.1 mm increase or decrease of shim thickness. The addition of shim thickness will retard the timing and reducing shim thickness will advance the timing. Another method of checking injection timing without removing the spring from under the delivery valve holder is to disconnect the high pressure injector line from the injector. With the number one piston at the beginning of its compression stroke, turn the crankshaft in the normal direction of rotation and watch carefully the fuel in the end of the high pressure line. The moment this fuel starts to swell and come out of the line, this is the injection timing point. By this method, the timing is about 1° later than the spill timing method previously discussed.

**ADJUSTING NO-LOAD ENGINE SPEEDS**

To adjust the engine speed on a generator, adjust the linkage between the throttle arm and the fuel run solenoid. Shortening the linkage increases the engine speed. Lengthening the linkage reduces the engine speed.

**NOTE:** This adjustment is performed with the engine operating and at normal operations temperature, with no amperage being taken from the generator. See the chart below:

GENERATOR MODELS	NO-LOAD SPEED (rpm)
60 hertz models	1850-1880 (61.5 - 62.0 hertz)
50 hertz models	1550 - 1580 (51.5 - 52.0 hertz)

**NOTE:** Any adjustment of the throttle on a generator is done only with the linkage between the fuel solenoid and the throttle lever.

**Propulsion Models.** This adjustment need only be performed after an engine overhaul or when the governor system or injection pump overhaul/repairs have been performed. This adjustment is performed after engine assembly during testing at the factory. See the chart below for no-load engine speed.

1. With the damper spring released (by loosening the damper spring adjusting bolt), set the engine at "a" rpm specified in the chart with the maximum speed set bolt. Lock the bolt at that position.

ENGINES	"a" rpm
W-27, RD80, W-27A, W-33, W-33A	3110 <sup>+0</sup> / <sub>-30</sub>
38B Four, 42B Four	3710 <sup>+0</sup> / <sub>-30</sub>

2. Tighten the damper spring adjusting bolt until the engine speed is set to (a) + 40 rpm, shown in the table below as (b) rpm. Lock the adjusting bolt at that position with a locknut. (Apply *Locktight* to the threads of the adjusting bolt.)

ENGINES	"b" rpm
W-27, RD80, W-27A, W-33, W-33A	3150 <sup>+0</sup> / <sub>-50</sub>
38B Four, 42B Four	3750 <sup>+0</sup> / <sub>-50</sub>

- a. Seal the above-mentioned adjusting bolt with its brass cap and crimp it on the bolt.
- b. Seal the maximum speed set bolt with wire and sealing material.

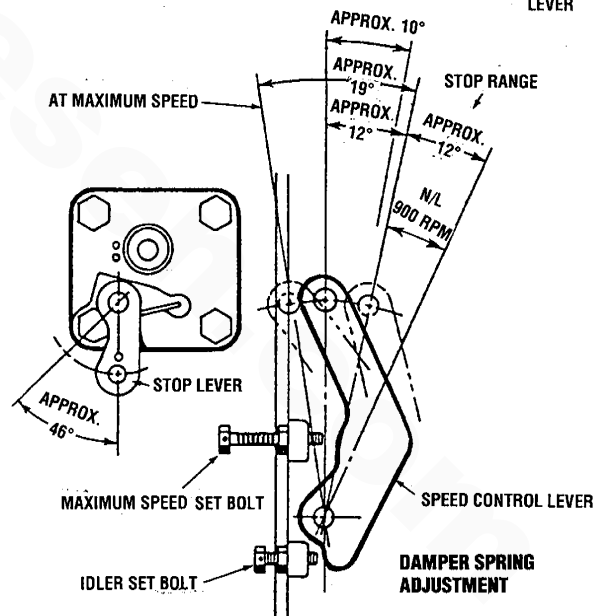
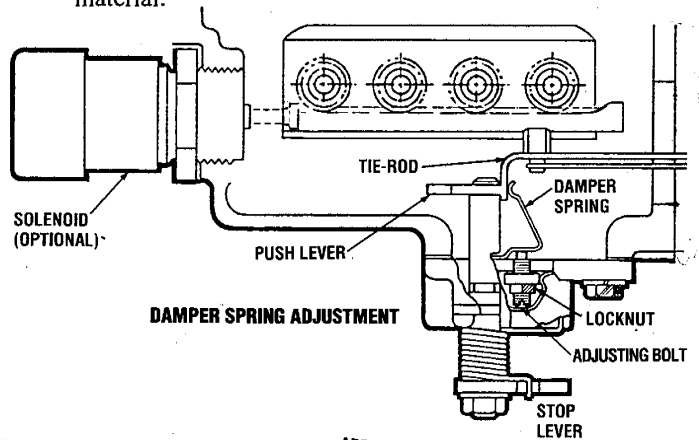

c. **Adjusting the Idling Speed.** Idling speed for most engines is between 800 and 1,000 rpm. Set the engine to the idling speed with the idling set bolt and lock the bolt at that position.



**DESCRIPTION**

The lubrication system uses a trochoid gear pump and a full flow oil filter. The oil pump is driven through the Oldham's coupling at the rear end of the fuel injection pump camshaft. Oil from the oil pump flows into the cartridge type oil filter via the relief valve. After being filtered by this filter, oil is delivered to various engine parts through oil galleries in the engine block.

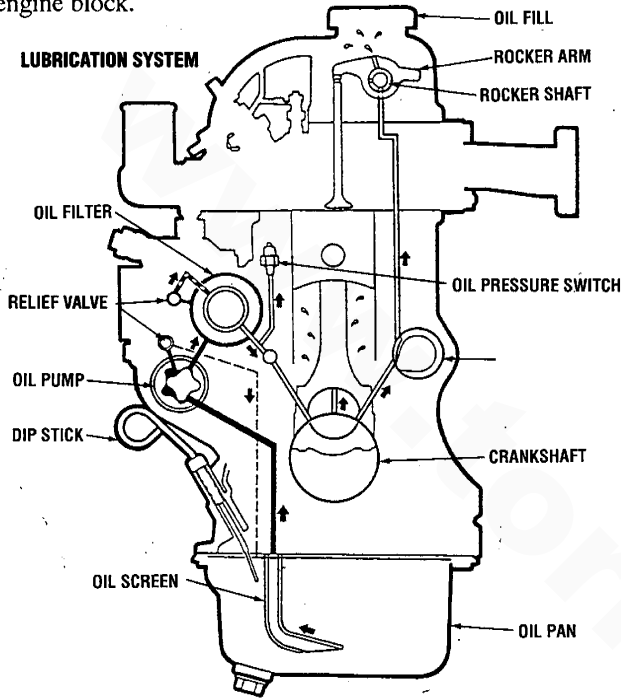

*The cartridge type oil filter*, in which the filter body is integral with the filter element, is easy to handle. Oil from the oil pump is led into the filter element. When a pressure difference between before and after the element exceeds 1 kg/cm<sup>2</sup> due to excessive clogging of the element, a bypass valve in the element will open an oil passage bypassing the element. As a result, oil flows to various engine parts without filtration. Therefore it is important to replace the oil filter regularly. The oil filter should be replaced after the initial 50 hours of operation and thereafter every 100 hours of operation.

*The trochoid gear type oil pump* is mounted on the back of the fuel injection pump on the right side of the cylinder block. The oil pump houses a relief valve. If pump delivery oil pressure exceeds 4 kg/cm<sup>2</sup>, the relief valve will open to by-pass oil into the oil pan, thus preventing further oil pressure rise.

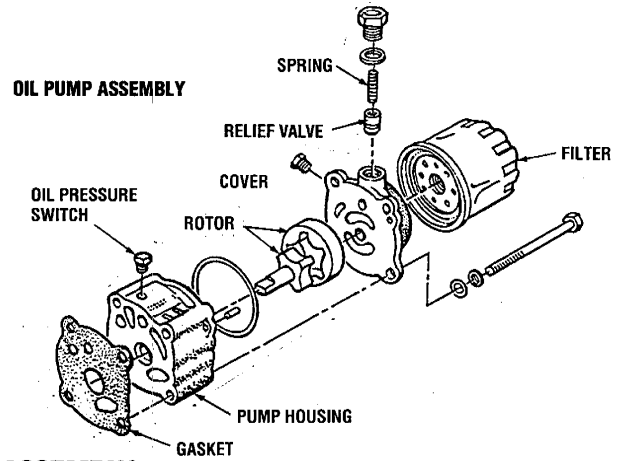

**DISASSEMBLY**

**Oil Filter and Oil Pump**

1. Remove the oil filter.
2. Remove the pump cover assembly, housing and gasket.

**INSPECTION**

**Oil Pump**

1. *Outer rotor to body clearance.* Using a feeler gauge, check the clearance between the outer rotor and body. If excessive, replace the rotor assembly.

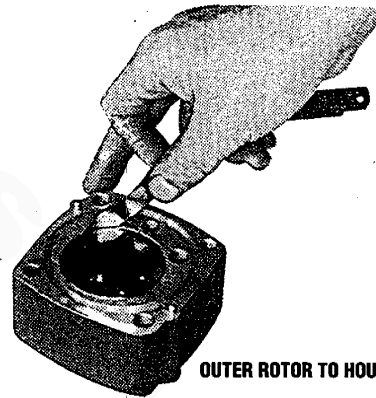

2. *Rotor clearance.* Check the clearance between the outer and inner rotors with a feeler gauge. If excessive, replace the rotor assembly.

Check the Oldham's coupling of the inner rotor shaft for cracks, damage and wear.

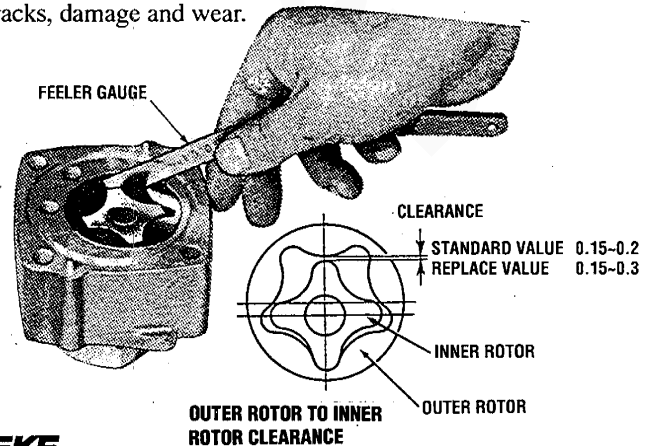

3. **Rotor to cover clearance.** With the outer rotor inserted in the pump body, insert a straightedge and check the clearance between the rotor and the straightedge with a feeler gauge. If excessive, replace either the rotor or the body.

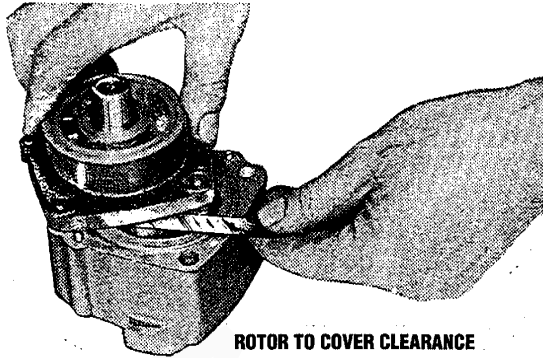

**ROTOR TO COVER CLEARANCE**

4. **Pump body O-ring.** Check the pump body O-ring for cracks and damage.
5. **Oil pressure switch/sender:** Replace the oil pressure switch and the oil pressure sender. On propulsion engines, the oil pressure switch is normally open. On generators, this switch is normally open; it closes when the oil pressure gets to 5–10 psi.

**CAUTION: Oil Pressure Switch — Do not use lock pliers, vise grips or pipe wrenches on the oil pressure switch. Use the correct socket which is available from Snap-On, Proto, New Britain and others. Damage to the switch will cause oil leaks and/or switch failure.**

### REASSEMBLY

1. Install the oil filter and tighten fully by hand. (Tightening torque: 1.1 to 1.3 kg-m.) Before installation, check for proper fitting of the O-ring in the groove and coat the O-ring with a small quantity of oil.
2. Install the gasket. Then install the oil pump housing, O-ring, rotor assembly and cover assembly in that order. Apply oil to the rotating parts.
3. With sealant applied to the threaded portion, screw in the oil pressure switch taking care not to close the oil hole with sealant.
4. Apply liquid teflon sealant to the threaded portion of the oil pressure sender. Take care not to close off the oil hole into the sender. Thread the sender into its fitting on the oil pump's housing.

### TESTING THE OIL PRESSURE

1. Start and warm up the engine.
2. Check for oil leaks at the filter and pump assembly.
3. Remove the oil pressure sender and connect a mechanical oil pressure gauge to the hole.
4. Set the engine speed at 3000 rpm and measure the oil pressure. It should be fairly constant at 3.5 kg/cm<sup>2</sup> (50 lb/in<sup>2</sup>).

**NOTE:** Insure that oil meets specification standards: Class CF or CG-4 or better/SAE 30 wt.

### OIL PRESSURE SWITCH

1. Later propulsion engines and all generators have a two-prong oil pressure/water temperature switch. When the oil pressure drops to 5–10 psi, this switch interrupts the circuit for the fuel run solenoid by opening, shutting down the engine/generator.

On early propulsion engines, this switch activates an alarm that emits a *pulsating* signal when the oil pressure drops too low (5–10 psi).

**NOTE:** This alarm will also emit a *pulsating* signal when the engine starts up, as the oil has not yet reached its normal pressure (a good check of the alarm).

**NOTE:** If this alarm emits a *continuous* signal (propulsion engines only), it indicates an engine overheat, with the operating temperature reaching 210°.

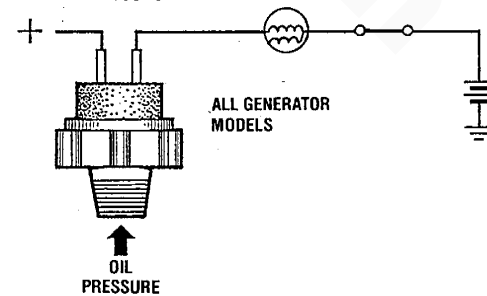
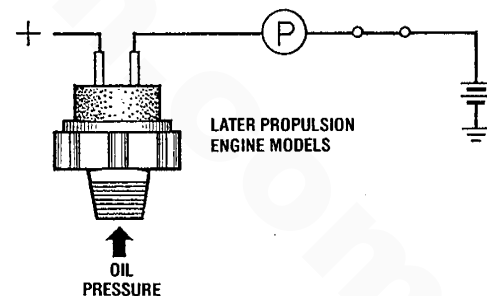
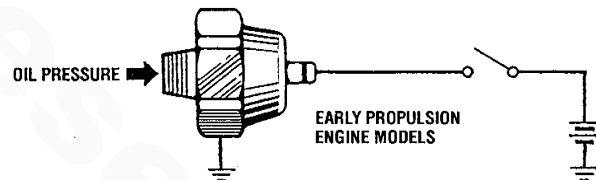

**OIL PRESSURE SWITCHES**

**DESCRIPTION**

An electromagnetic fuel lift pump draws fuel from the diesel supply through an (owner supplied) fuel/water separator to the engine's primary fuel filter and on to the fuel injection pump. The pressurized fuel is then injected into the combustion chamber through the injection pipes and nozzles. Excess fuel is returned to the fuel supply through the fuel return pipes that connect to the top of each nozzle holder.

**NOTE:** Fuel supplied to the fuel lift pump must be filtered to 75-200 microns by the (owner supplied) fuel/water separator.

The built-in four-cylinder fuel injection pump is mounted on the right side of the cylinder block. It consists of the pump elements (plunger assemblies), delivery valves, tappets and smoke set unit. As the pump camshaft rotates, the plungers are moved up and down through a fixed stroke, thus delivering pressurized fuel to engine cylinders.

**Fuel injection control.** Fuel injection rate is dependent on the relative positions of the plunger lead and barrel. The plunger is rotated by the control pinion which is mounted on the plunger barrel. This pinion meshes with the plunger's lower collar which transmits the rotation of the pinion directly to the plunger. As the engine runs, the injection pump camshaft rotates to move the control rack through the centrifugal type governor weight, governor sleeve and lever. The control rack slides to turn this pinion. Rightward movement (STOP mark side) of the control rack decreases the fuel injection rate; as the rack moves to the left, the fuel increases.

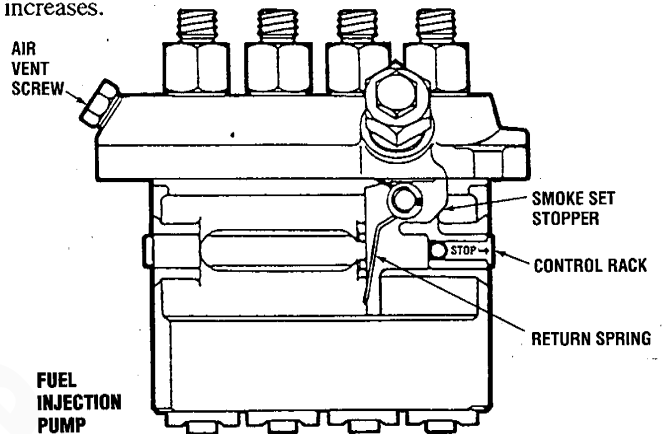
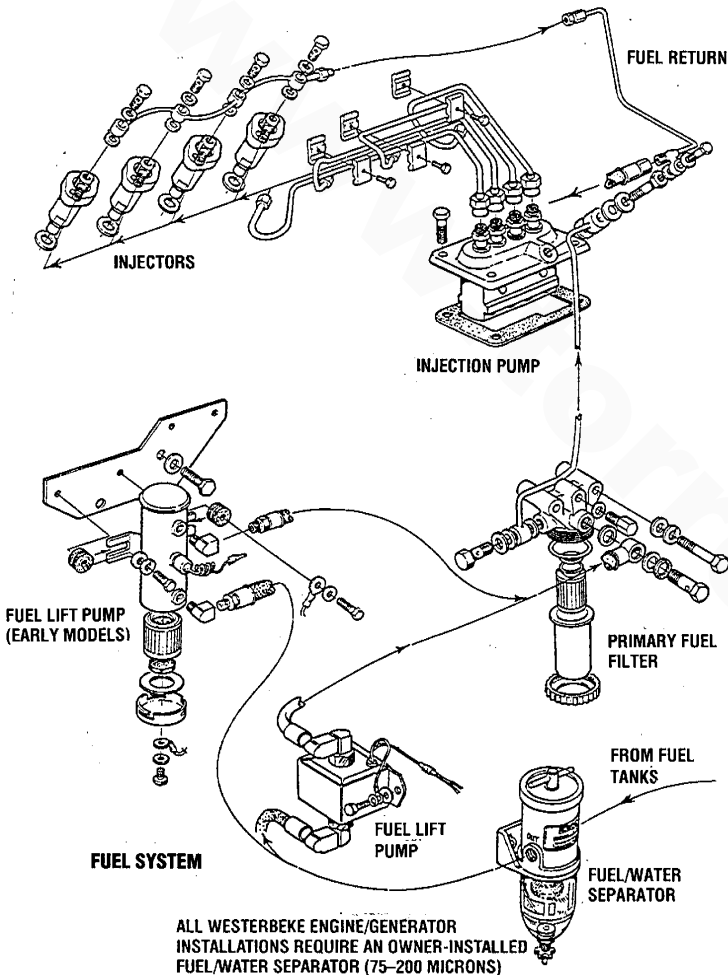

**Smoke set unit.** The smoke set unit restricts the maximum fuel injection rate of the injection pump. The stopper is held by a spring in the position shown in the illustration. This position is the smoke set position. When starting the engine (propulsion models), pull the throttle control lever fully toward the maximum speed position, and the tie-rod (with stopper spring) will move the control rack in the arrowed direction against the spring force, thus causing over-injection for easy engine start. For the injection pump with the Angleich mechanism, over-injection requires releasing that mechanism.

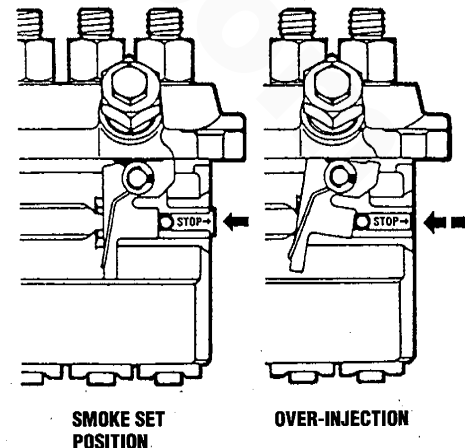

**Fuel Pump.** Two types of fuel lift pumps are shown in the illustration; both operate on the same electromagnetic principle. Earlier model engines use a lift pump with a replaceable fuel element. This element should be changed at regular maintenance intervals (at 250 hours). Later model engines use a smaller lift pump that does not require maintenance. Electrical connections should be kept clean and tight with either pump.

The primary fuel filter encloses a highly effective paper element. This filter assembly is located on the engine between the fuel pump and the injection pump. The paper element should be changed at regular maintenance intervals.

**Angleich Mechanism.** The Angleich Mechanism restricts the movement of the smoke set plate in the narrower range (Angleich effect "L") to save fuel consumption and decrease emission of exhaust smoke.

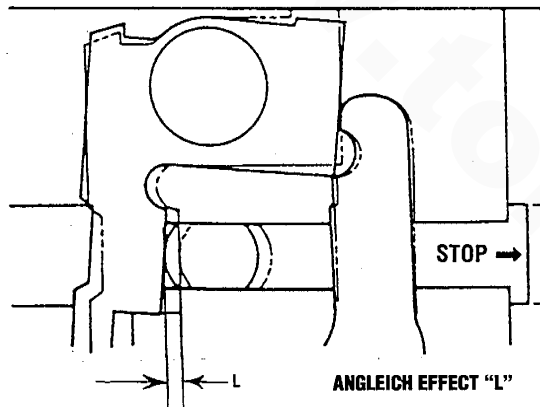
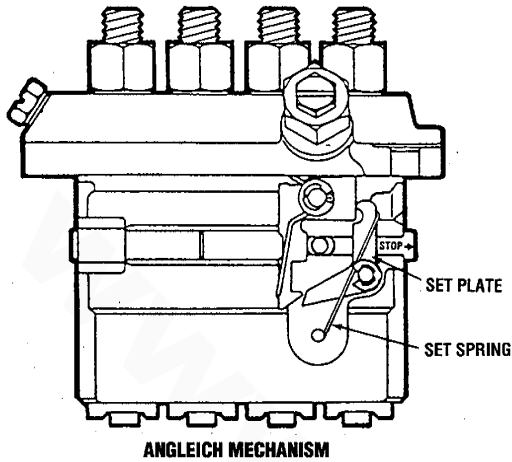

**Releasing the Angleich Mechanism.** It is necessary when starting the engine to set the injection pump in the over-injection (MS) condition by moving the throttle control lever fully to the FULL-OPEN position. This requires the Angleich set plate to be released from its set position. Usually the Angleich set plate is released by pulling the throttle lever until it is caught by its stopper when stopping the engine. After starting the engine, the Angleich set plate is returned automatically to the applied position during warm-up running of the engine.

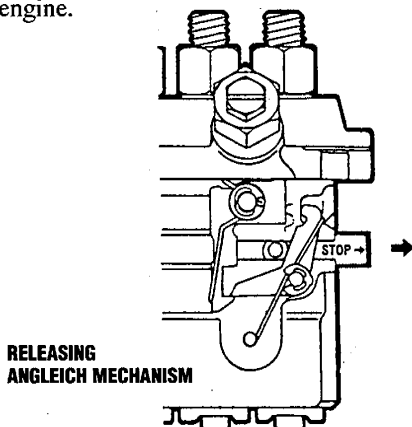

**The intercylinder injection control.** Fuel injection control among the cylinders is performed by the adjusting plates which have their own cam mechanisms. These adjusting plates are located on the opposite side of the control rack. Necessary turning of the plunger barrels required for inter-cylinder injection control is attained by turning the respective adjusting plates. This adjustment is performed on a fuel shop flow bench only.

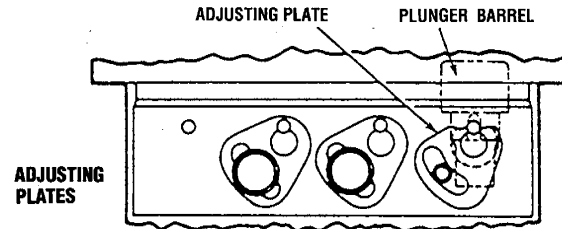

**Delivery valve operation.** The delivery valve's function is to deliver fuel to the injection pipes after the fuel pressure has been increased sufficiently, and to prevent "after-drip" from the nozzles. When the fuel pressure above a plunger has decreased after injection, its delivery valve piston closes the delivery valve seat. At this time the compressed fuel remaining in the injection pipe drips from the nozzle. To prevent this "after-drip", the delivery valve piston makes a stroke to draw back the fuel before the delivery valve reaches the seat, thus reducing the fuel pressure in the injection pipe to nearly zero.

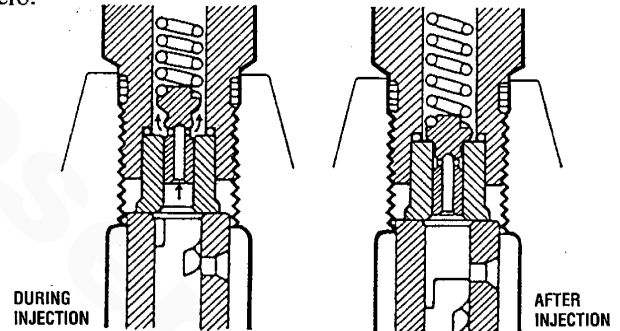

**Nozzle and nozzle holder.** Fuel from the fuel injection pump flows through the passage in the body of each nozzle holder and is injected from the nozzle into the combustion chamber. Fuel overflowing from the nozzle enters the nozzle holder and returns to the fuel tank through the banjo and attached return fuel line.

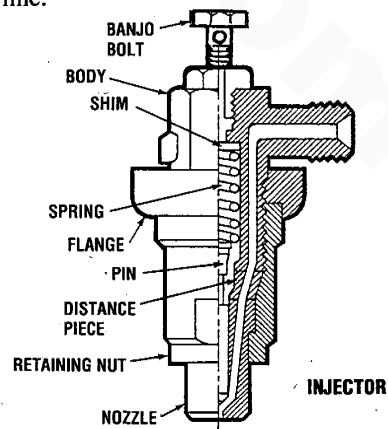

**DISASSEMBLY**

**Fuel Filter**

Remove the retaining nut, O-ring and filter element.

**Fuel Lift Pump**

The fuel lift pump requires little or no maintenance. For early model fuel lift pumps, disassemble and change the filter. Later model fuel lift pumps require no disassembly. Fuel to the pump must be filtered to 75-200 microns. Electrical connections at the pump must be clean and tight. Fuel connections at the pump must be tight and without leaks.

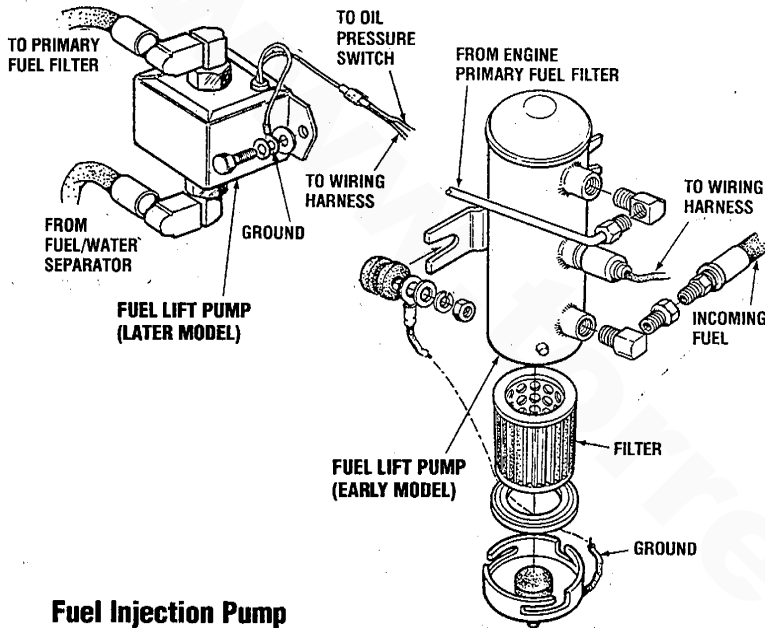

- a. Remove the delivery valve holder.
- b. Take out the valve spring, valve and O-ring.
- c. Take out the gasket and valve seat.
- d. Unbend the lock plate of the tappet guide pin. Push the tappet slightly in and pull out the guide pin using a pincette. Then remove the tappet.
- e. Remove the spring and upper seat.
- f. Remove the pinion.
- g. Pull out the plunger barrel upward from the pump housing. Keep the removed plunger barrels and plungers in a set for each cylinder. (Do not mix plungers and barrels of other cylinders.)
- h. Pull off the split pin. Remove the washer, return spring and smoke set stopper. Draw out the control rack. Remove the Angleich set spring and plate, if equipped, before taking out the control rack.

**CAUTION:** Do not disassemble the inter-cylinder injection control adjusting plate. When this plate has been disassembled, it will become necessary to adjust the inter-cylinder injection by a tester. When this plate requires removal, remember to draw a mating mark across the pump body and the plate.

**Fuel Injection Pump**

1. Remove the fuel injection pipes.
2. Before removing the pump, be sure to remove the pump side cover and disconnect the tie-rod and spring from the rack. Then remove the bolts fastening the injection pump and remove the pump assembly.
3. Record the thickness and number of pump adjusting shims to facilitate adjustment at the time of assembly.
4. When partly disassembling the fuel injection pump, use the following procedure.

**CAUTION:** Do not attempt to disassemble the fuel injection pump unless it is necessary. Since the adjustment of an injection pump requires a pump tester and technical disassembly, reassembly and adjustment of a pump should not be performed if such a tester and technician aren't available. Before disassembly, close the fuel inlet and outlet and clean the pump's outside surfaces. Keep disassembled parts immersed in clean kerosene and keep all parts neatly arranged in order to avoid confusion.

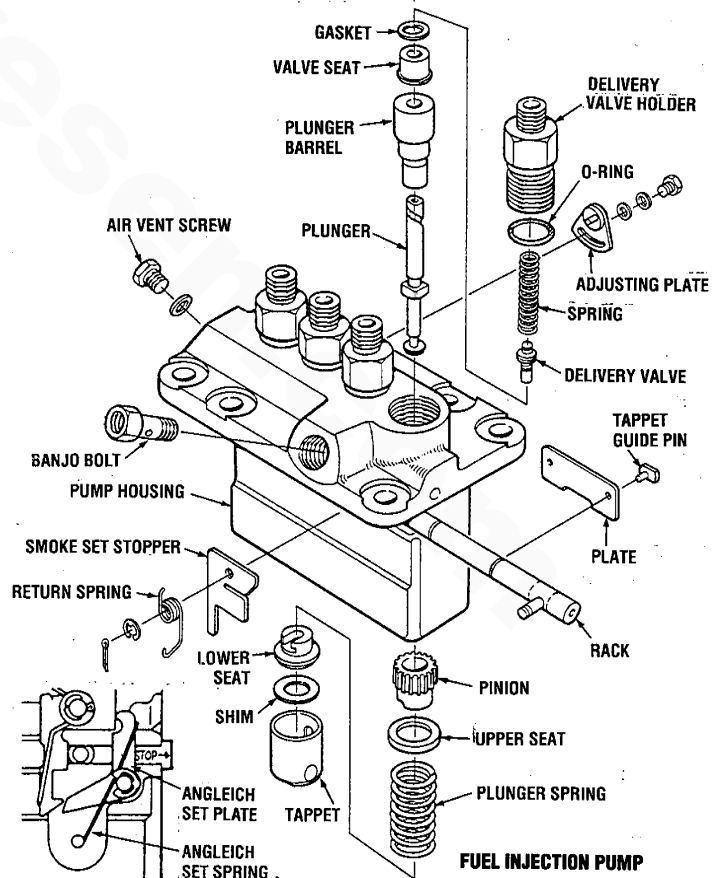

## Injector

1. Disconnect the return pipe from the nozzle holder upper nipple.
2. Disconnect the fuel injection pipe from the nozzle holder.
3. Loosen the nozzle holder attaching bolts and remove the holder assembly.
4. When disassembling the nozzle holder into parts, use the following procedure:
  - a. Holding the nozzle holder body in a vice, remove the retaining nut with a spanner wrench. When holding in the vice, be sure to use an aluminum or copper plate adapter.
  - b. Remove the shim, pressure spring, flange, pressure pin and distance piece.
  - c. Remove the nozzle from the retaining nut. If the nozzle is hard to remove, apply light taps to it with a wooden block. Be careful not to damage the nozzle needle valve.

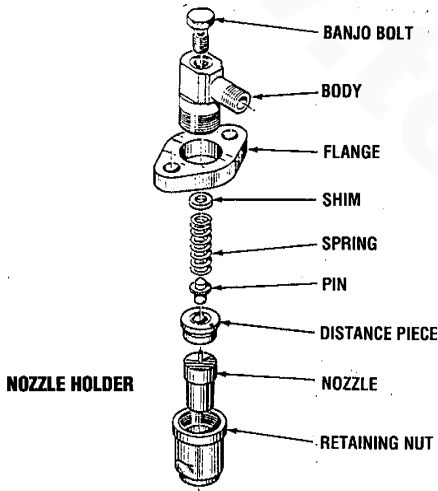

## INSPECTION

### Fuel Filter

Check the filter element for contamination. The regular element replacement interval is 250 hours. Replace the element more frequently if necessary.

### Fuel Lift Pump

The fuel pump operates during the start sequence when PRE-HEAT is depressed. Simulate a start and depress PREHEAT. The pump should produce a clicking sound indicating the pumping piston in the pump is pumping. If no clicking is heard, check that there is 12V DC at the pump connection and that the pump is properly grounded.

1. **Checking the pump delivery.** Test the pump by connecting a battery and fuel line, as illustrated. Fuel delivery must be 225 cc (.5 pints) or more every 15 seconds.

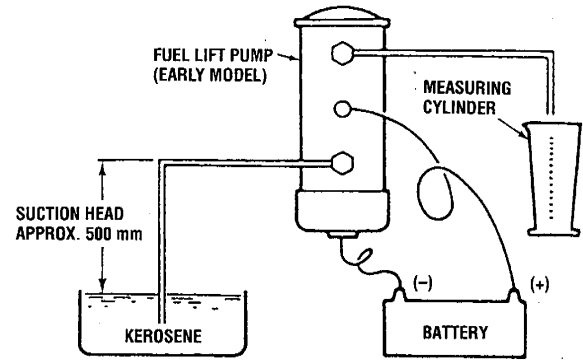

TESTING THE FUEL LIFT PUMP

## Fuel Injection Pump

1. **Delivery valve seat.** Check the contact surface of the delivery valve seat. Replace if defective.
2. **Plunger barrel.** Check the plunger for seizure, damage and rust. Also check to see if the plunger slides smoothly when inserted into the barrel. If defective, do not repair it, but be sure to replace as a set with a new one.
3. **Control rack and pinion.** If the rack and pinion have any worn or damaged teeth, replace.
4. **Tappet.** Check the tappet O.D., roller and shaft for wear and damage. If defective, replace.

## Nozzle

1. Check the nozzle for incorrect contact and damage. Replace the nozzle as an assembly if defective.
2. Check the pressure spring for damage.

**NOTE:** Also check the Angleich set plates and set springs for wear and damage.

## REASSEMBLY

### Fuel Filter

Install the filter element and filter cup O-rings in position. Tighten the retaining nut securely.

### Fuel Lift Pump

To reassemble, set the plunger, plunger spring, valve, O-ring and washer in position in that order, and as a final step, fit the retainer to prevent the above-mentioned parts from popping out of position, (see illustration).

Put the filter in position and fit the magnet and gasket in the cover. Using a 17 mm spanner, fasten up to the stopper portion in such a way as to prevent air leakage.

## Injection Pump

1. Insert the plunger barrel with its slots in alignment with the dowel pins projecting in the pump housing.
2. Install the O-ring in the delivery valve holder.

3. Install the spring seat gasket and the valve assembly in the holder. Tighten the delivery holder to the pump housing. Make certain that the O-ring has been properly installed.

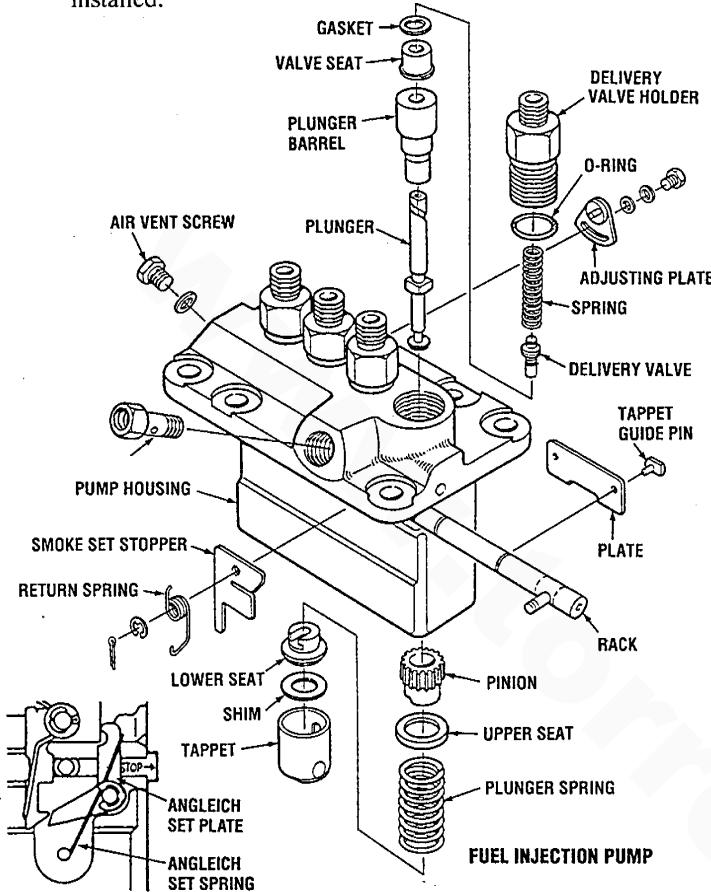

4. Install the control rack.
5. Install the pinions with their deep-root teeth aligned with the respective marks on the rack.

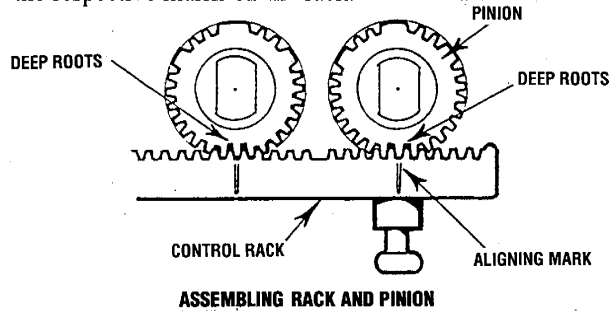

6. Install the spring upper seat and spring.
7. Put the plunger and the spring lower seat together. Install the assembly so that, in the same alignment position as mentioned in step 5, the plunger front-end lead (slant groove) is positioned on the opposite side of the control rack. On former engines, insert the mark "L" area of the plunger collar into the control rack side.
8. Insert the tappet, taking care not to drop the shim. Align the tappet guide hole with the dowel pin hole of the housing and insert the tappet guide pin. Install the lock plate

before inserting the tappet guide pin and bend the lock plate after inserting the pin.



**INSTALLING TAPPET**

9. Install the smoke set stopper, return spring and washer. Then insert the split pin, and split it.
10. Install the Angleich set plate and spring, when equipped.
11. Torque the delivery holder to specification (4-5 kg-m).

**Installation and Adjustment of Fuel Injection Pump**

1. When installing the pump assembly, select and install the adjusting shim. After installing the pump, fit the tie-rod from the governor lever to the control rack, then install the tie-rod spring to the control rack. Make sure that the end of the tie-rod spring positioned at the governor lever side has the shorter straight wire of the two ends of the spring. For proper selection of shim thickness, temporarily install a shim set having the same thickness as before removal, and when adjusting fuel injection timing, replace the current shim set with one formed by a proper combination of four kinds of shims. - 0.2, 0.3, 0.4 and 0.8 mm, in thickness.

**NOTE:** Maintaining the same shim thickness for the injection pump will place the pump in the same timing with the engine as when previously removed.

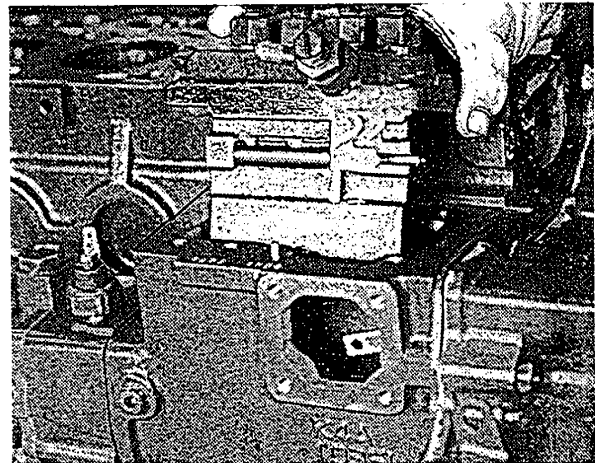

**INSTALLING INJECTION PUMP**



2. Install the tie-rod cover. In the case of a damper spring-loaded cover, install the cover with the tie-rod pressed toward the High Speed side by the speed control lever (see illustration).

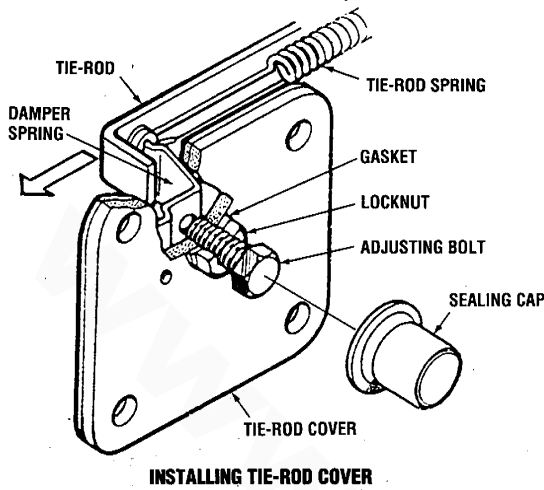

3. Connect the fuel supply hose. Preheat to bleed air from the system.
4. Check damper spring adjustment and fuel injection timing. For these adjustment procedures, refer to *ENGINE ADJUSTMENTS*.

### Injector

**CAUTION:** Thoroughly clean all parts with kerosene. Do not wipe them with rags.

**When tightening the retaining nut on the nozzle holder body, be sure to tighten it to the specified torque. Insufficient torquing will cause poor compression. Excessive torquing will prevent the nozzle needle from moving freely.**

1. Install the nozzle assembly, distance piece, and pressure pin in the retaining nut.
2. Install the shim, spring and flange to the body. Install the retaining nut on the body and tighten to the specified torque.

**CAUTION:** When using a vice to tighten the nut, be sure to hold the body side. If the retaining nut was held, a deformed nozzle would result.

### Adjustment and Installation of Nozzle Holder Assembly

1. **Injection Start Pressure Test.** Using a nozzle tester, measure the injection start pressure. If the pressure is different from the standard value, adjust to the specified pressure by increasing or decreasing the thickness of the adjusting shim. Increasing or decreasing shim thickness by 0.1 mm will vary the pressure by approximately 10 kg/cm<sup>2</sup>. When replacing the shim, grip the retaining nut in a vise and remove the body with a wrench. Tighten the retaining nut to the specified torque.

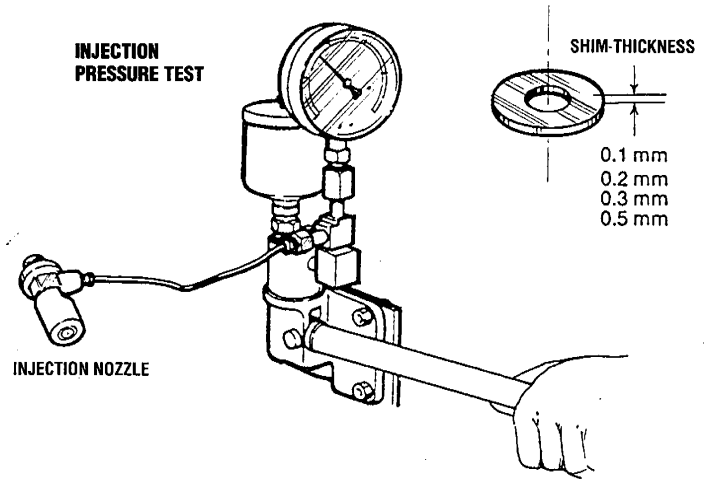

2. **Chattering Test.** For the chattering test, operate the tester lever slowly. If the nozzle sprays sharply and intermittently, the nozzle is considered good. The nozzle should spray fuel straight in its axial direction. A nozzle is defective if it sprays fuel in a wrong direction or in several separate strips. Also a spray in the form of particles indicates a defect. These defects may sometimes be caused by clogging with dust, therefore all parts should be carefully cleaned before assembly.

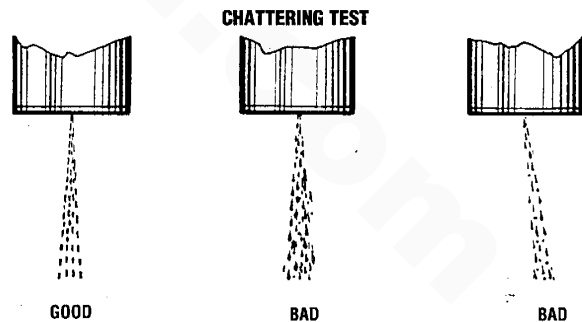



3. **After-drip test.** An injection nozzle is considered defective if it drips fuel accumulated on the bottom of the nozzle after fuel injection is stopped during the chattering test. Replace such a nozzle. A very small amount of fuel may sometimes remain on the top of the nozzle. This is due to chattering and is not detrimental.



4. **Injection Condition Test.** Operate the tester lever quickly (at a rate of 800 strokes per minute). The nozzle should inject a fine atomized mist of fuel straight in its axial direction. A spray in the form of particles is cause for rejection.
5. **Install the Nozzle Holder Assembly.** Install the tested nozzle holder assembly in the cylinder head. Tighten bolts to the specified torque. Be sure to install the assembly together with new sealing washers.

**⚠ CAUTION:** *When installing the nozzle holder assembly in the cylinder head, fit the holder loosely with two bolts temporarily tightened. After fitting the injection pipe, retighten the bolts evenly to the specified torque.*

**DESCRIPTION**

*The raw water cooling circuit* is driven by a positive displacement impeller pump. This pump draws in water directly from an ocean, lake, or river, through the seacock, then to a raw water strainer. The raw water is drawn through the strainer to the self-priming pump and to the heat exchanger where it cools the engine's circulating fresh water coolant. The raw water is then discharged into the water injected exhaust elbow mixing with and cooling the exhaust gases. This mixture of exhaust gas and raw water is driven through the exhaust system and overboard.

*Transmission oil cooler.* In some installations the raw water is also used to cool the engine's transmission by passing through a transmission oil cooler. Similar to a heat exchanger, the transmission fluid is cooled by the raw water and then passes into the exhaust elbow. The oil cooler should be cleaned and pressure tested at about the same interval as the heat exchanger, every 1000 hours.

*The heat exchanger* functions as part of the fresh water system and the raw water system. The heat exchanger is a copper tube which encloses a number of small copper tubes. Raw water is pumped through the small copper tubes and fresh water coolant from the engine is circulated around the copper tubes. The raw water removes heat from the fresh water coolant. A zinc anode is located in the raw water portion of the exchanger to help control the effects of electrolysis. This area of the exchanger should be periodically inspected and cleaned. To keep the exchanger operating efficiently, it should be removed from the engine every 1000 hours to be thoroughly cleaned and pressure tested.

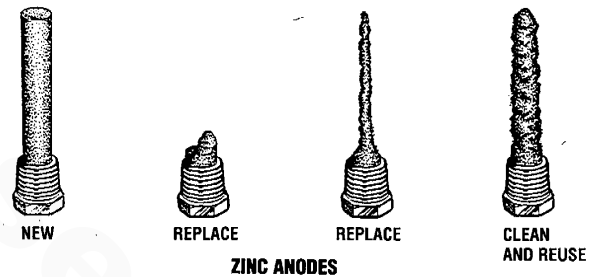
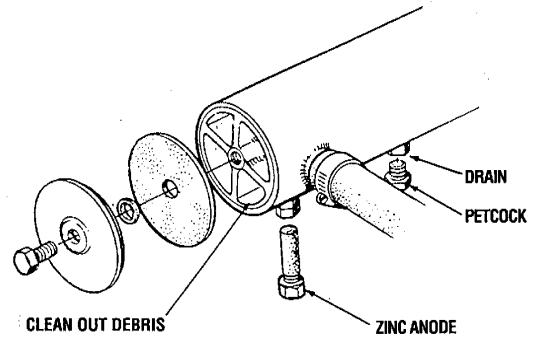
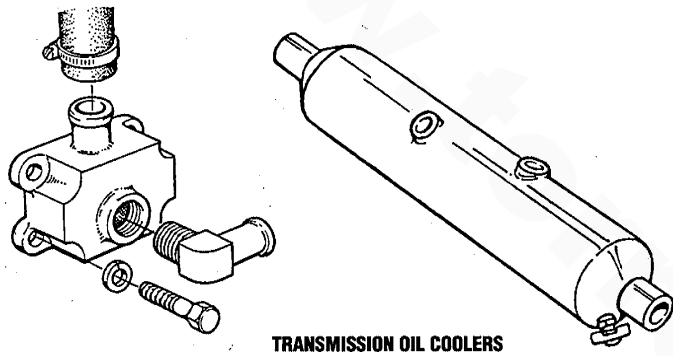

*The raw water pump* is a self-priming pump with a non-ferrous housing and a Neoprene impeller. The impeller has flexible vanes which wipe against a curved cam plate within the impeller housing, producing the pumping action. The raw water pump impeller should be checked every 500 operating hours for wear. Should the pump fail, it can be disassembled and overhauled. Check for internal wear within the pump such as the cover plate, cam and impeller housing. Replace components that show excess wear.

**RAW WATER PUMP — PN 33636**

**PUMP OVERHAUL**

**Disassembly**

The pump, as removed from the engine, will have hose attachment nipples threaded into its inlet and outlet ports. They may be left in place or removed if they interfere with the pump disassembly. Note the port location and positioning if removed.

1. Remove the six cover plate screws, cover plate, and the cover plate gasket.  
**NOTE:** Replacement of the cover plate gasket is recommended; however, if you are going to reuse it, keep the gasket submerged in water until the pump is reassembled. If it's allowed to dry, the gasket will shrink and not be reusable.
2. Remove the impeller with its drive screw from the pump housing.
3. Remove the screw and sealing washer and remove the cam from the pump housing.
4. Remove the retaining ring.
5. Support the pump housing, at the mounting flange end, on an arbor press, and with a drift, press out the shaft and bearings from the pump housing.
6. With the pump housing supported, push the seals out of the pump housing. Push the impeller side seal out the impeller side, then lift the spacer out. Then push the bearing side seal out the bearing side.
7. Supporting the bearing's inner race, push the shaft out of the bearings.

**Inspection**

Inspect all parts and replace those showing wear or corrosion.

**Reassembly**

1. Install the seals and spacer in the pump housing. Push the impeller side seal into the housing. Rotate the pump and install the spacer against the seal face. Push the bearing side seal into the housing from the bearing side.

**NOTE:** The seals' flat surfaces that have printing and numbers face toward each other.

2. Install the shaft into the bearings. Support the bearings at their center races. Push the shaft into the bearings, pushing at the impeller drive slot end using the base of the drive slot. Push the shaft through both of the bearings, flush against each other so the flat-sided end of the shaft extends beyond the second bearing center race 15 mm (19/32 in.) ± .5 mm (1/32 in.).
3. Support the pump housing at the impeller side. Apply a small amount of petroleum jelly to the seal's inner lips and to the impeller shaft. Carefully install the shaft, rotating it through the seals until the bearings contact the housing from the bearing end. Use a pushing tool that will push this shaft and the bearing assembly into the pump housing by applying pressure against the outer bearing race. Push the assembly into the housing until the bearings seat fully in the housing. Install the retaining ring.
4. Position the cam in the housing and secure it in place with the screw and sealing washer.  
**NOTE:** Use a small amount of Permatex #1 on the inner cam surface and screw threads. Remove any excess from the impeller housing.
5. Apply a light film of silicone or petroleum jelly to the inner surface of the housing for the impeller.  
**NOTE:** Coat only the surface, do not over-apply. Install the impeller with the drive screw. Push the assembly into the housing with the drive screw mating in the slot of the drive shaft.  
**NOTE:** Coat only the surface, do not over-apply. Install the impeller with the drive screw. Push the assembly into the housing with the drive screw mating in the slot of the drive shaft.
6. Install the cover gasket and cover, and secure them with the six cover screws.
7. Reposition and tighten the hose nipples. Assemble the pump to the engine, and attach the hoses.

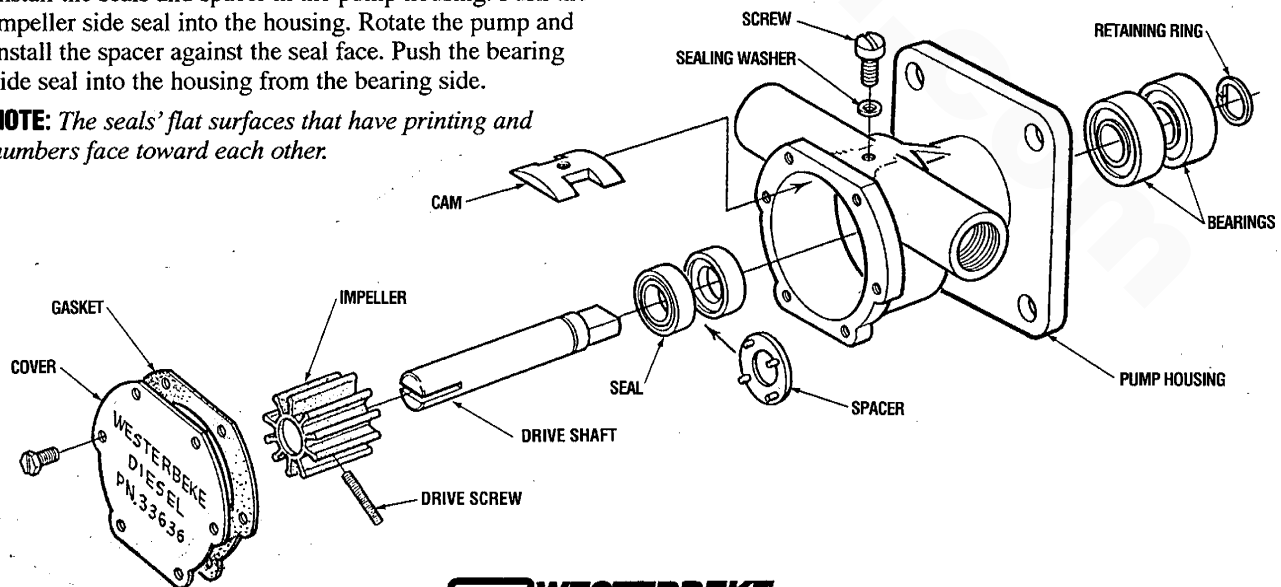

**RAW WATER PUMP — PN 24143**

Pump #24143 has been replaced by pump #33636. Complete #24143 pumps are no longer assembled but their component parts are still available.

**PUMP OVERHAUL**

**Disassembly**

Remove the pump from the engine. The pump body is a bronze cast unit. Its inlet and outlet hose connections are part of the pump housing casting.

1. Remove the six cover plate screws along with the cover plate and gasket.
2. Using an appropriate drift, push the impeller drive shaft and impeller out of the pump housing.
3. Using circlip pliers, remove the outer circlip from the impeller drive shaft, then remove the impeller from the shaft.
4. Remove the key from the shaft, and the inner circlip.
5. Remove the screw holding the cam in the pump housing, and remove the cam.
6. Using an appropriate puller, withdraw the outer and inner shaft seals along with the slinger ring from the pump body.
7. Support the pump on a press and with a lubricated drift, push the carbon shaft bushing out of the pump housing. Note the position of the shaft bushing in the housing prior to removal.

**Inspection**

Examine all components and replace worn or damaged parts. If the pump housing is worn internally and requires replacement, we recommend that the pump assembly be replaced with the current production pump. It is available in a replacement kit, Part #037431.

**Reassembly**

1. The carbon shaft bushing is a slight force fit into the pump housing. To aide in the installation of the replace

ment bushing, chill the bushing in a freezer for 1 hour to reduce it's size. Prepare the pump housing on a press to accept the bushing.

2. Apply some light oil to the housing boss that the bushing will be pressed into. Using an appropriate drift, push the bushing into the housing so that it is flush with the impeller housing's inner surface.
3. Using an appropriate installer, install the impeller shaft seal. Ensure that the seal seats properly in the housing and that the lip seal is positioned correctly.
4. Place the slinger ring in the housing against the impeller seal.
5. Install the impeller shaft oil seal into the housing so it is flush with the housing surface. Again ensure that the lip seal is positioned correctly.
6. Install the inner circlip on the impeller drive shaft, and install the impeller key in the shaft.
7. Apply some light oil to the shaft, and with a rotating action, slide it into the shaft bushing from the impeller side and rotate it through the impeller seal. Locate the slinger ring and rotate the shaft through it. Continue rotating the shaft and slide it through the housing oil seal.
8. Install a new cam. Apply some sealant to the cam retaining screw and thread it into the cam through the housing and tighten it securely.
9. Apply a small amount of petroleum jelly on the housing's inner circumference, then install the impeller onto the shaft and into the housing. Install the outer circlip on the shaft.
10. Install the housing cover and gasket. Tighten the cover screws securely.

**NOTE:** The set of the impeller blades is of no concern. Once the pump is installed on the engine and the engine rotated, the blades will take the correct position.

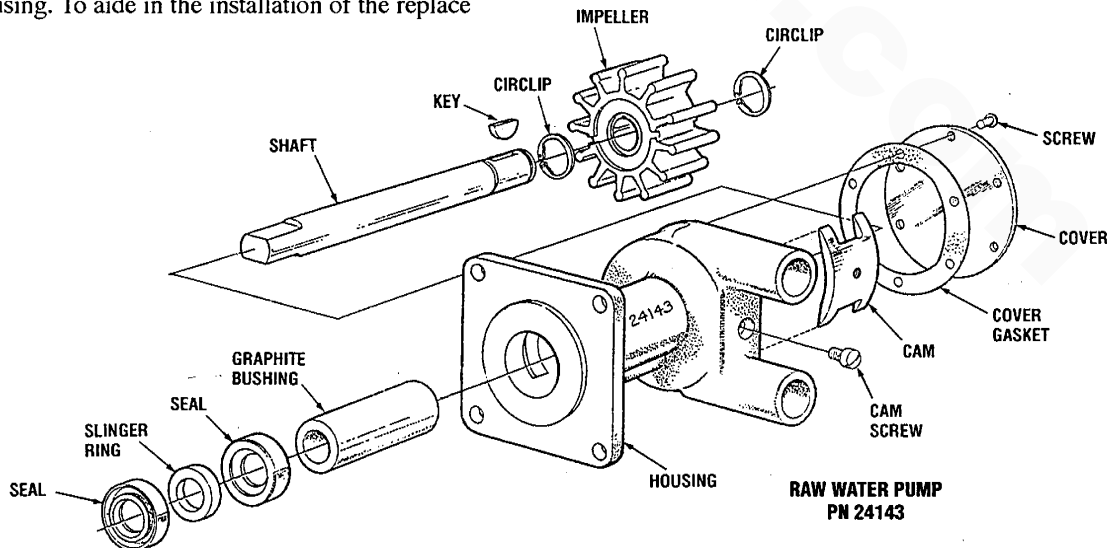

**DESCRIPTION**

The fresh water cooling circuit consists of a circulatory belt-driven water pump, a thermostat and thermostat housing, heat exchanger, engine manifold, and all associated hoses.

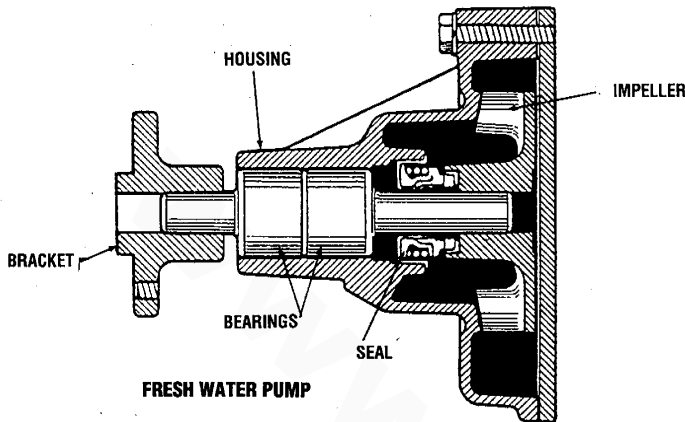

*The water pump* is a centrifugal impeller type and is mounted on the front upper part of the cylinder block. The pump shaft is supported on maintenance-free (grease-filled) double-row radial ball bearings.

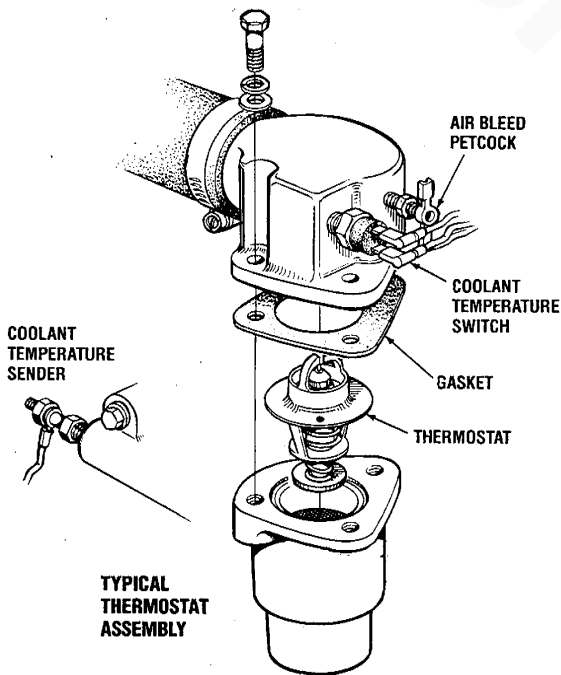

**Thermostat.** A thermostat housing is located on the cylinder head water outlet. Enclosed is a wax pellet-type thermostat. The valve opening temperature is not affected by variations of pressure in the cooling water passages.

*The water temperature switch and the water temperature sender* are both mounted in the thermostat housing. The water temperature switch, normally open in a propulsion engine, when activated, will close and sound an alarm. The water temperature switch, normally closed in a generator drive engine, when activated, will open and interrupt DC Voltage to the fuel run solenoid and shut the drive engine down. The water temperature sender is a variable resistor affected by heat. Voltage from the water temperature gauge is grounded through the sender to the block. Depending on the resistance through the sender effected by coolant heat, the gauge will indicate a temperature reading.

**Change of Coolant.** Over a long period of engine operation, scale will be deposited and rust formation will occur in the water jacket and heat exchanger, causing progressive deterioration in cooling system efficiency. For this reason, flush the cooling system every 500 hours of engine operation.

**Antirust and Antifreeze.** To protect the cooling system against corrosion and freezing, always use a known brand of antifreeze compatible with aluminum cooling system components. The use of an antifreeze mixture of 50/50 is recommended for year-round use. Use antifreeze that is compatible with aluminum components, and never mix different brands of antifreeze. *Do not use plain water*; this can be detrimental to the cooling system components.

**NOTE:** Look for the new environmentally-friendly long lasting antifreeze that is now available.

Antifreeze mixtures will protect against an unexpected freeze and they are beneficial to the engine's cooling system. They retard rust and add to the life of the circulating pump seal.

**ANTIFREEZE PROTECTION**

Antifreeze concentration	23%	35%	50%	60%
Freezing temperature	14°F (-10°C)	-4°F (-20°C)	-40°F (-40°C)	-58°F (-50°C)

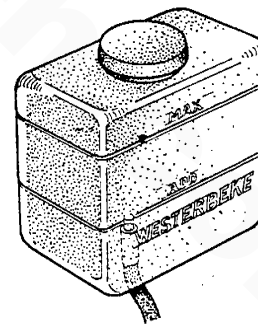

**COOLANT RECOVERY TANK**

## DISASSEMBLY

1. Drain the cooling water. A drain plug for draining the engine block is located on the side of the engine block just right of the lube oil filter. A drain plug for draining the heat exchanger is located on the heat exchanger.
2. Disconnect the water hose from the pump.  
**NOTE:** Generator models are equipped with belt guards that will need to be removed.
3. Remove the pump drive belt.
4. Disconnect the bypass hose when equipped.
5. Remove the water pump assembly.
6. If necessary, remove the water pump adapter when equipped.
7. On an engine with a thermostat, remove the water outlet fitting bolts in the front of the cylinder head and remove the thermostat.

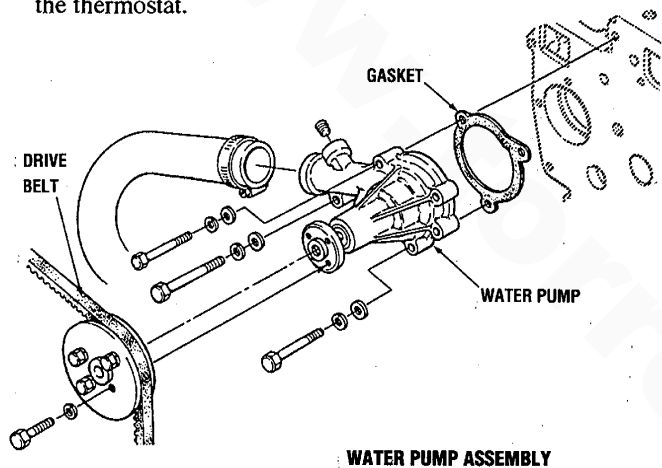

## INSPECTION

### Water Pump

1. Check every part for cracks, damage and water leaks. Replace if defective.  
**NOTE:** No rebuilding kits are available for the fresh water circulation pump.
2. Check the impeller and shaft for rotating condition. If they make noise or rotate irregularly, replace as an assembly.

## Thermostat

Visually check the thermostat for damage. Then put it in water and raise the water temperature to test its valve opening temperature. Replace if defective.

**CAUTION:** *The wax pellet-type thermostat remains closed if its heat-sensing part is defective. Leaving this uncorrected would cause the engine to overheat.*

## REASSEMBLY

To reassemble the cooling system, reverse the order of disassembly. When adjusting the drive belt tension, use the following procedure.

## Drive Belt Adjustment

**WARNING:** *Never attempt to adjust the drive belt tension while the engine is operating.*

**CAUTION:** *Excessive water pump drive belt tension can cause rapid wear of the belt and reduce the service life of the fresh water pump's bearings. Excessive slack or the presence of oil on the belt can cause belt slipping, resulting in high operating temperatures.*

Adjust the alternator position so that the belt may deflect 3/8" to 1/2" deep when depressed at the middle point between the alternator and crankshaft pulleys. After adjustment, securely tighten the support bolt and brace bolt. If any clearance is found between the gear case and alternator fitting part, insert a suitable shim inside the support on the back of the alternator before tightening the bolts. Reinstall belt.

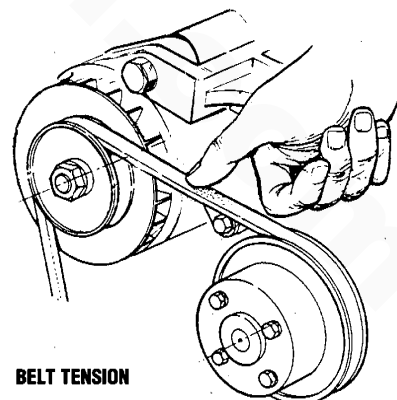

## ADMIRAL CONTROL PANEL

### DESCRIPTION

This manually-operated control panel is equipped with a KEY switch and RPM gauge with an ELAPSED TIME meter which measures the engine's running time in hours and in 1/10 hours. The panel also includes a WATER TEMPERATURE gauge which indicates water temperature in degrees Fahrenheit, an OIL PRESSURE gauge which measures the engine's oil pressure in pounds per square inch, and a DC control circuit VOLTAGE gauge which measures the system's voltage. All gauges are illuminated when the key switch is turned *on* and remain illuminated while the engine is in operation. The panel also contains two rubber-booted pushbuttons, one for PREHEAT and one for START.

When the engine is shut down with the key switch turned *off*, the water temperature gauge will continue to register the last temperature reading indicated by the gauge before electrical power was turned *off*. The oil pressure gauge will fall to zero when the key switch is turned *off*. The temperature gauge will once again register the engine's true temperature when electrical power is restored to the gauge.

A separate alarm buzzer with harness is supplied with every Admiral Panel. The installer is responsible for electrically connecting the buzzer to the four-pin connection on the engine's electrical harness. The installer is also responsible for installing the buzzer in a location where it will be dry and where it will be audible to the operator should it sound while the engine is running. The buzzer will sound when the ignition key is turned *on* and should silence when the engine has started and the engine's oil pressure rises above 15 psi.

**WATER TEMPERATURE GAUGE:** THIS GAUGE IS GRADUATED IN DEGREES FAHRENHEIT AND IS ILLUMINATED WHILE THE KEY SWITCH IS TURNED ON. THE ENGINE'S NORMAL OPERATING TEMPERATURE IS 170°-190° F (77°-88°C).

**OIL PRESSURE GAUGE:** THIS GAUGE IS GRADUATED IN POUNDS PER SQUARE INCH (PSI) AND IS ILLUMINATED WHILE THE KEY SWITCH IS TURNED ON. THE ENGINE'S NORMAL OPERATING OIL PRESSURE RANGES BETWEEN 30-60 PSI.

**RPM GAUGE:** REGISTERS REVOLUTIONS PER MINUTE OF THE ENGINE AND CAN BE RECALIBRATED FOR ACCURACY FROM THE REAR OF THE PANEL.

**OUR METER:** REGISTERS ELAPSED TIME, AND SHOULD BE USED AS A GUIDE FOR THE MAINTENANCE SCHEDULE.

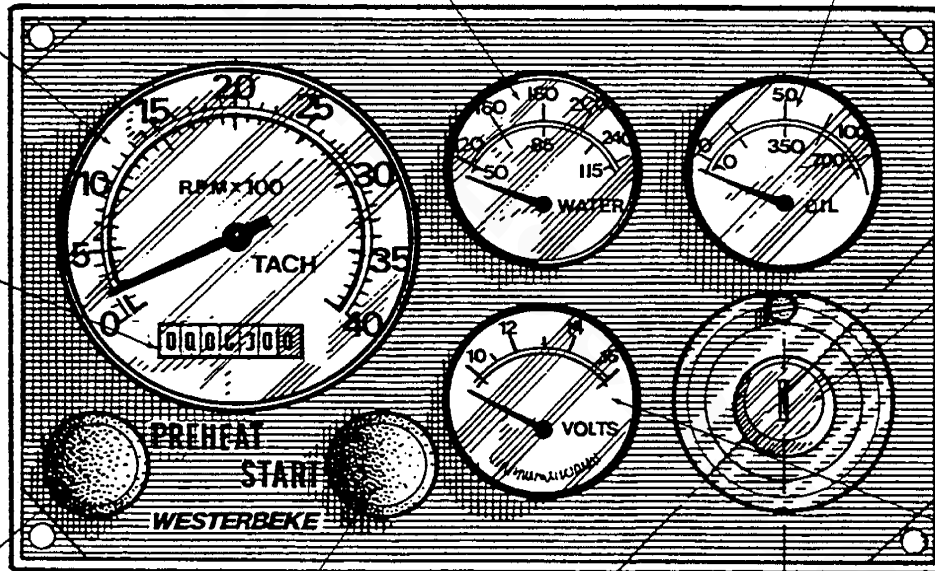

**KEY SWITCH:** PROVIDES POWER ONLY TO THE INSTRUMENT PANEL CLUSTER.

**DC VOLTMETER:** INDICATES THE AMOUNT THE BATTERY IS BEING CHARGED. SHOULD SHOW 13V TO 14V.

**PREHEAT BUTTON:** WHEN PRESSED, ENERGIZES THE ALTERNATOR'S EXCITER, THE FUEL LIFT PUMP, THE FUEL SOLENOID ON THE INJECTION PUMP, AND THE ENGINE'S GLOW PLUGS. IT BY-PASSES THE ENGINE'S PROTECTIVE OIL PRESSURE ALARM SWITCH. IN ADDITION, THIS BUTTON ENERGIZES THE START BUTTON.

**START BUTTON:** WHEN PRESSED, ENERGIZES THE STARTER'S SOLENOID WHICH CRANKS THE ENGINE. THIS BUTTON WILL NOT OPERATE ELECTRICALLY UNLESS THE PREHEAT BUTTON IS PRESSED AND HELD AT THE SAME TIME.

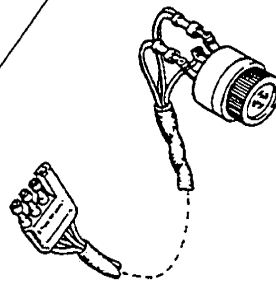

### AUTOMATIC ALARM SYSTEM

**HIGH WATER TEMPERATURE ALARM:** AN ALARM BUZZER HAS BEEN SUPPLIED WITH THE INSTRUMENT PANEL. IF THE ENGINE'S FRESH WATER COOLANT REACHES 210° F (98°C), THIS SWITCH WILL CLOSE SOUNDING THE ALARM WHICH WILL EMIT A CONTINUOUS SIGNAL.

**LOW OIL PRESSURE ALARM:** A LOW OIL PRESSURE ALARM SWITCH IS LOCATED OFF THE ENGINE'S OIL GALLERY. THIS SWITCH MONITORS THE ENGINE'S OIL PRESSURE. SHOULD THE ENGINE'S OIL PRESSURE FALL TO 5 - 10 PSI, THE SWITCH WILL CLOSE SOUNDING THE ALARM. IN THIS EVENT, THE ALARM WILL EMIT A PULSATING SIGNAL.

## CAPTAIN CONTROL PANEL

### DESCRIPTION

This manually-operated control panel is equipped with a KEY switch, an RPM gauge, PREHEAT and START buttons, an INSTRUMENT TEST button and three indicator lamps, one for ALTERNATOR DISCHARGE, one for low OIL PRESSURE, and one for high ENGINE COOLANT TEMPERATURE. It also includes an alarm buzzer for low

OIL PRESSURE or high WATER TEMPERATURE. The RPM gauge is illuminated when the KEY switch is turned *on* and remains illuminated while the engine is in operation.

**RPM GAUGE:** REGISTERS REVOLUTIONS PER MINUTE OF THE ENGINE AND CAN BE RECALIBRATED FOR ACCURACY FROM THE REAR OF THE PANEL.

**ALARM:** THE ALARM WILL SOUND IF THE ENGINE'S OIL PRESSURE FALLS BELOW 15 PSI. IN THIS EVENT, THE ALARM WILL EMIT A PULSATING SIGNAL. THE ALARM WILL ALSO SOUND IF THE WATER TEMPERATURE IN THE FRESHWATER COOLING CIRCUIT RISES TO 205°F. IN THIS EVENT, THE ALARM WILL EMIT A CONTINUOUS SIGNAL.

**NOTE:** THE ALARM WILL SOUND WHEN THE KEY SWITCH IS TURNED ON. THIS SOUNDING IS NORMAL. ONCE THE ENGINE STARTS AND THE ENGINE'S OIL PRESSURE REACHES 15 PSI, THE ALARM WILL SILENCE.

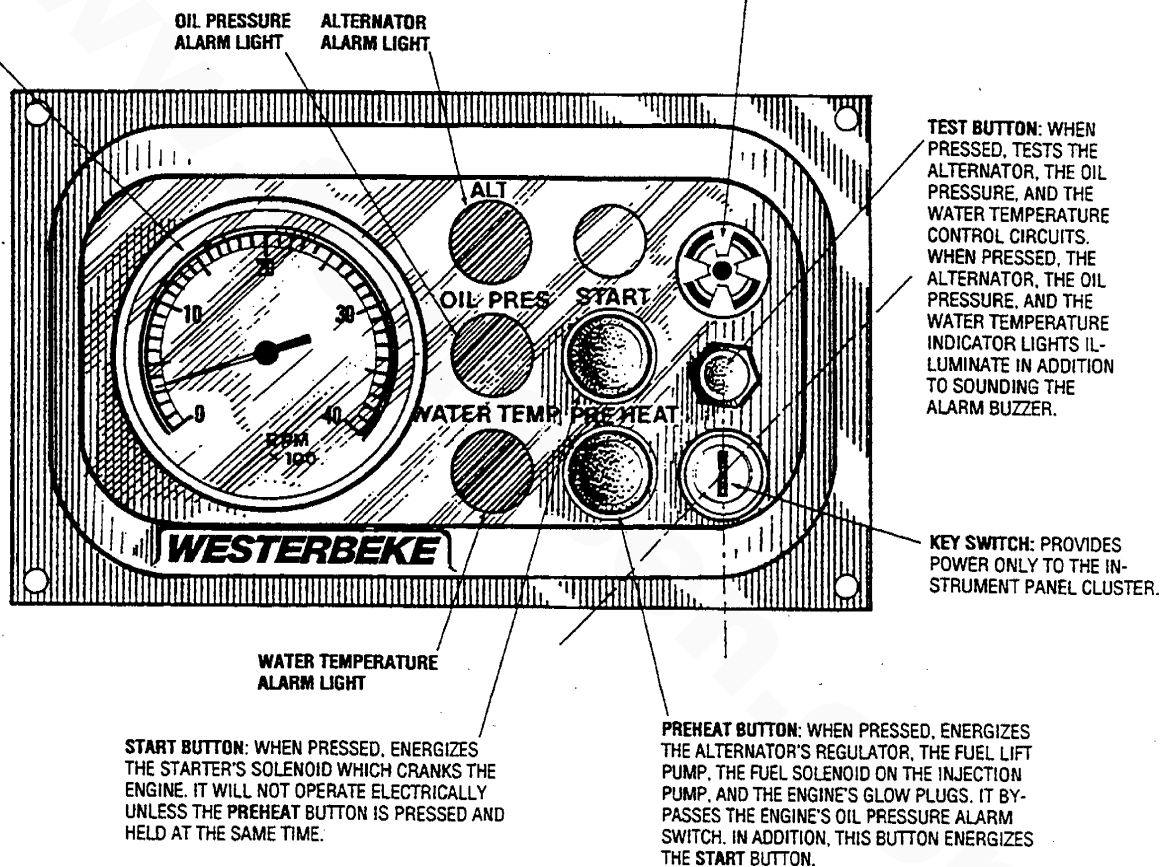



## CONTROL PANEL TROUBLESHOOTING

### TACHOMETER/HOURMETER

The tachometer/hourmeter used in propulsion engine instrument panels contains two separate electrical circuits with a common ground. One circuit operates the hourmeter and the other the tachometer. The hourmeter circuit operates on 12 volts alternator charging voltage supplied to the (+) terminal on the back of the instrument.

The tachometer circuit operates on AC voltage 6-8 volts, fed from one of the diodes in the alternator and supplied to the tachometer input terminal while the engine is running, and the alternator producing battery charging voltage 13.0-14.8 volts DC.

Use the following procedures when troubleshooting a fault in either of the two circuits in a tachometer/hourmeter.

### Hourmeter Inoperative

Check for the proper DC voltage between (+) and (-) terminals.

1. Voltage present – meter is defective – repair or replace.
2. Voltage not present – trace (+) and (-) electrical connections for fault. (Jump 12 volts DC to meter (+) terminal to verify the operation.)

### Tachometer Inoperative

Check for the proper AC voltage between tachometer input terminal and the (-) terminal with the engine running.

1. Voltage present – attempt adjusting the meter through the calibration access hole. If no results, repair or replace the meter.
2. AC voltage not present – check for proper alternator DC output voltage.
3. Check for AC voltage at the tach terminal on the alternator to ground.
4. Check the electrical connections from the tachometer input terminal to the alternator connection.

### Tachometer Sticking

1. Check for proper AC voltage between the tachometer input terminal and the (-) terminal.
2. Check for a good ground connection between the meter (-) terminal and the alternator.
3. Check that the alternator is well grounded to the engine block at the alternator pivot bolt.

### Tachometer Inaccurate

1. With a hand-held tach on the front of the crankshaft pulley retaining nut or with a strobe-type tach, read the front crankshaft pulley rpm. Set the engine with a hand or strobe tach at 1500-1800 rpm.
2. Adjust the tachometer with a small Phillips type screwdriver through the calibration access hole in the rear of the tachometer. Zero the tach and bring it to the rpm set by the strobe or hand tach. (Verify the rpm at idle and at high speed 2500-3000 rpm). (Adjust the tach as needed.)

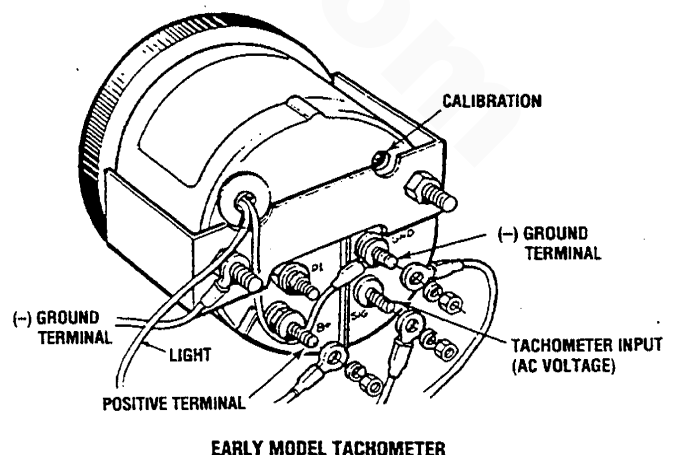
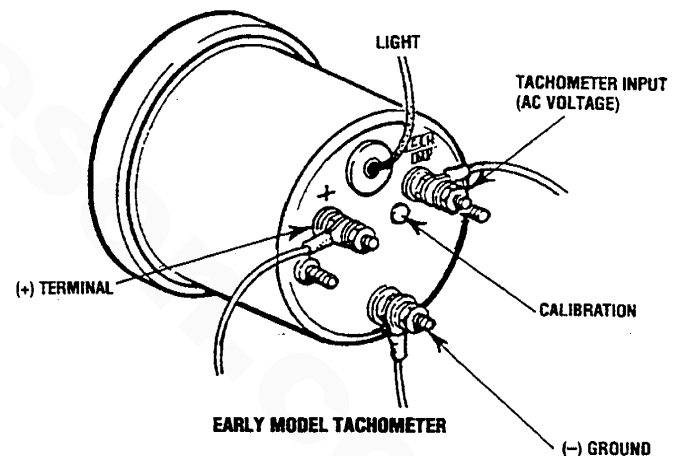
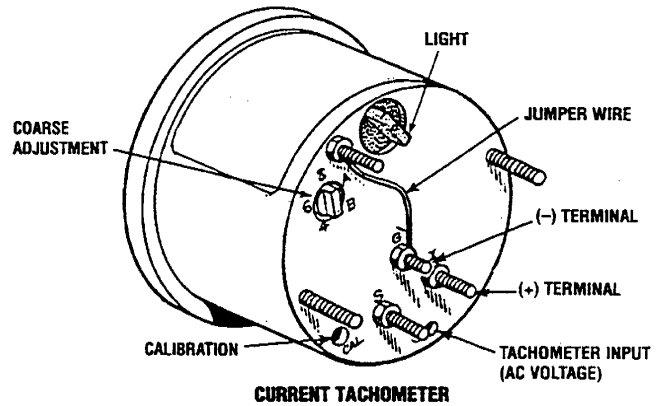

## CONTROL PANEL TROUBLESHOOTING

### MANUAL STARTER DISCONNECT (TOGGLE SWITCHES)

**NOTE:** The engine control system is protected by a 20 amp manual reset circuit breaker mounted on a bracket at the top rear of the engine near the PREHEAT circuit.

PROBLEM	PROBABLE CAUSE	VERIFICATION/REMEDY
<b>PREHEAT</b> depressed, no panel indications, fuel solenoid, electric fuel pump and preheat solenoid not energized.	<ol style="list-style-type: none"> <li>1. Battery switch or power not on.</li> <li>2. 20 amp circuit breaker tripped.</li> </ol>	<ol style="list-style-type: none"> <li>1. Check switch and/or battery connections.</li> <li>2. Reset breaker. If opens again, check preheat solenoid circuit and "run" circuit for shorts to ground.</li> </ol>
<b>START SWITCH DEPRESSED</b> , no starter engagement.	<ol style="list-style-type: none"> <li>1. Connection to solenoid faulty.</li> <li>2. Faulty switch.</li> <li>3. Faulty solenoid.</li> <li>4. Loose battery connections.</li> <li>5. Low battery.</li> </ol>	<ol style="list-style-type: none"> <li>1. Check connection.</li> <li>2. Check switch with ohmmeter.</li> <li>3. Check that 12 volts are present at the solenoid connection.</li> <li>4. Check battery connections.</li> <li>5. Check battery charge state.</li> </ol>
<b>START DEPRESSED</b> , panel indications OK. Start solenoid OK. Fuel solenoid not functioning.	<ol style="list-style-type: none"> <li>1. Poor connections to fuel solenoid. Defective fuel run solenoid. (P/N 2304)</li> </ol>	<ol style="list-style-type: none"> <li>1. Check mechanical positioning of the fuel solenoid for plunger and throttle arm.</li> <li>2. Manually check movement of the fuel run solenoid plunger and throttle arm.</li> </ol>
<b>NO IGNITION</b> , cranks, does not start. Fuel solenoid energized.	<ol style="list-style-type: none"> <li>1. Faulty fueling system.</li> </ol>	<ol style="list-style-type: none"> <li>1. Check for fuel to generator system.</li> <li>2. Check for air in the fuel system. Allow system to self-bleed.</li> <li>3. Full lift pump faulty.</li> </ol>
<b>ENGINE STOPS</b>	<ol style="list-style-type: none"> <li>1. Switch and wiring.</li> </ol>	<ol style="list-style-type: none"> <li>1. Inspect all wiring for loose connections and short circuits.</li> </ol>
<b>NOT CHARGING BATTERY</b>	<ol style="list-style-type: none"> <li>1. Alternator drive.</li> </ol>	<ol style="list-style-type: none"> <li>1. Check the drive belt and its tension. Be sure the alternator turns freely. Check for loose connections. Check the output with a voltmeter. Ensure 12V are present at the regulator terminal.</li> </ol>
<b>BATTERY RUNS DOWN</b>	<ol style="list-style-type: none"> <li>1. Oil pressure switch.</li> <li>2. High resistance leak to ground.</li> <li>3. Low resistance leak to ground.</li> <li>4. Alternator.</li> </ol>	<ol style="list-style-type: none"> <li>1. Observe if the gauges and panel lights are activated when the engine is not running. Test the oil pressure switch.</li> <li>2. Check the wiring. Insert sensitive (0-.25 amp) meter in battery lines (Do not start engine). Remove connections and replace after short is located.</li> <li>3. Check all wires for temperature rise to locate the fault.</li> <li>4. Disconnect alternator at output, after a good battery charging. If leakage stops. Remove alternator and bench test. Repair or replace.</li> </ol>

### TROUBLESHOOTING WATER TEMPERATURE AND OIL PRESSURE GAUGES

If the gauge reading is other than what is normally indicated by the gauge when the instrument panel is energized, the first step is to check for 12 volts DC between the ignition (B+) and the Negative (B-) terminals of the gauge.

Assuming that there is 12 volts as required, leave the instrument panel energized and perform the following steps:

1. Disconnect the sender wire at the gauge and see if the gauge reads zero, which is the normal reading for this situation.
2. Connect the sender terminal at the gauge to ground and see if the gauge reads full scale, which is the normal reading for this situation

If both of the above gauge tests are positive, the gauge is undoubtedly OK and the problem lies either with the conductor from the sender to the gauge or with the sender.

If either of the above gauge tests are negative, the gauge is probably defective and should be replaced.

Assuming the gauge is OK, check the conductor from the sender to the sender terminal at the gauge for continuity.

Check that the engine block is connected to the ground. Some starters have isolated ground terminals and if the battery is connected to the starter (both plus and minus terminals), the ground side will not necessarily be connected to the block.



## CONTROL PANEL – EARLY MODELS

### ACTIVATION BY KEY SWITCH

Turning the ignition switch ON activates the instrument panel. The oil and water temperature gauges will zero, the voltmeter will indicate battery voltage, and the hourmeter will start to record time. The alarm buzzer should sound. The electric fuel pump will start to operate.

Pushing the key will activate the preheat circuit. This closes a solenoid on the engine with an audible click and supplies 12 volts to the engine glow plugs. Preheat as needed for weather conditions. A noticeable voltage drop will indicate on the voltmeter when the preheat circuit is activated.

Continuing to preheat, turn the key to START. This energizes the starter and turns the engine over. Once the engine starts, release the keyswitch. It should spring back to the ON position and pop out of the preheat position.

The voltmeter should indicate a charge from the alternator of 13.5 – 14.5 volts. The oil pressure and the alarm buzzer should shut off. Oil pressure opens the oil pressure switch in the alarm circuit shutting off the alarm. The water temperature switch operates the opposite way: it closes when an

overheat condition exists and the operating temperature of the engine reaches 205°F, and sounds the alarm. The tachometer will register the engine speed as it takes impulses from the alternator as it charges. If the alternator does not produce a charge, the tachometer will not operate. The hourmeter will continue to record time. The hourmeter is on a separate 12 volt circuit.

The circuit is protected by a circuit breaker located on the engine. Whenever excessive current flows, the circuit breaker will trip. This is a manual reset breaker which must be reset before the engine will operate electrically again.

**⚠ CAUTION:** *The builder/owner must ensure that the instrument panel, wiring and engine are installed so that electrical devices cannot come in contact with sea water.*

The latest information regarding your engine's electrical system is included on the wiring diagram shipped with the engine. Be sure to study this wiring diagram and all notes thereon.

**PROPULSION ENGINE**

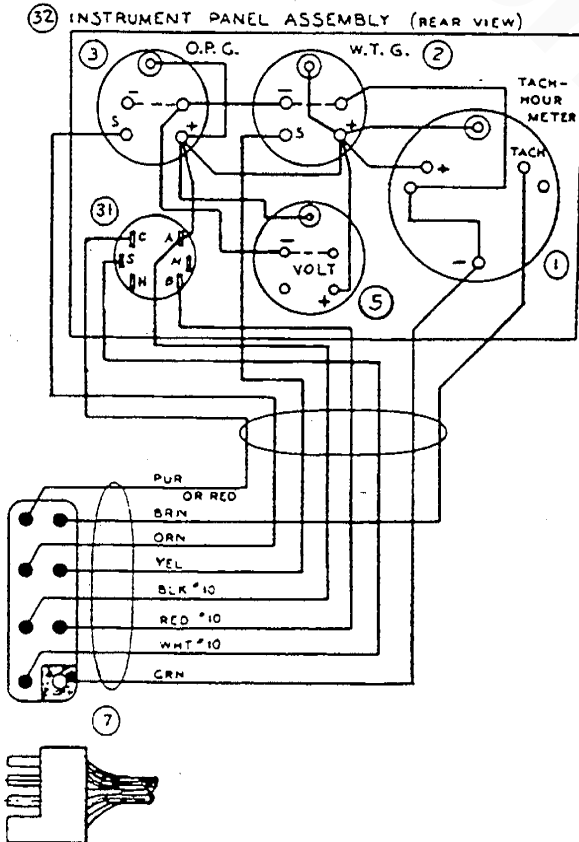

**GENERATOR**

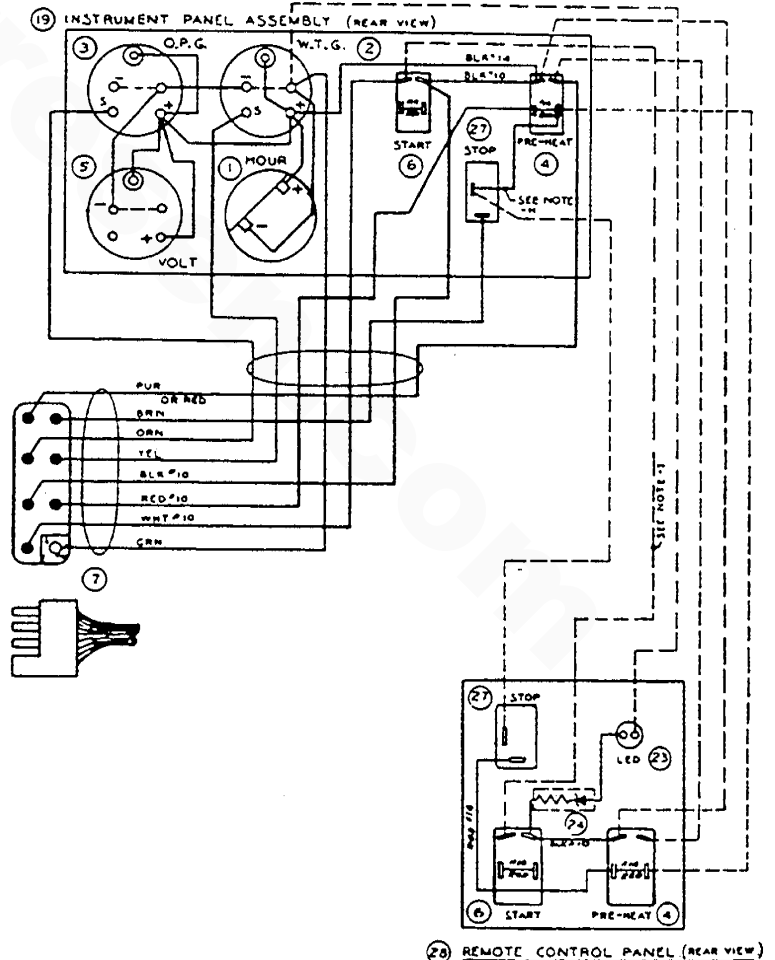

## STARTER/SOLENOID SERVICE

### DESCRIPTION

The starter can be roughly divided into the following sections:

- A motor section which generates a drive power.
- An overrunning clutch section which transmits an armature torque, preventing motor overrun after starting.
- A switch section (solenoid) which is operated when actuating the overrunning clutch through a lever and which supplies load current to the motor.

The starter is a new type, small, light-weight, and is called a high-speed internal-reduction starter. Its differences in construction from conventional starters are as follows:

- In conventional starters, the pinion slides on the motor shaft (armature shaft). In the new type of starter, the pinion shaft is separate from the motor shaft; the pinion slides only on the pinion shaft.
- A reduction gear is installed between the motor shaft and the pinion shaft.
- The pinion sliding part is not exposed outside the starter so that the pinion may slide smoothly without becoming fouled with dust and grease.
- The motor shaft is supported at both ends on ball bearings. The lever mechanism, switch and overrunning clutch inner circuit are identical to conventional ones.

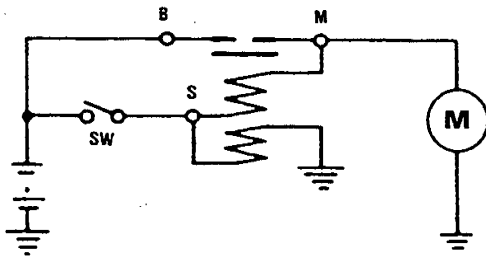

STARTER WIRING

2. Lightly push the pinion back and measure the return stroke (called pinion gap).
3. If the pinion gap is not within the standard range (0.5 to 2.0 mm), adjust it by increasing or decreasing the number of shims on the solenoid. The gap is decreased as the number of shims increases.

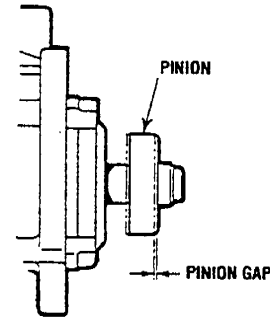

### No-Load Test

1. Connect the ammeter, voltmeter, and battery to the starter (see illustration).
2. When the switch is closed, the pinion must protrude and the starter must run smoothly (at 3000 rpm or more). If the current or starter speed is out of specification, disassemble the starter and repair it.

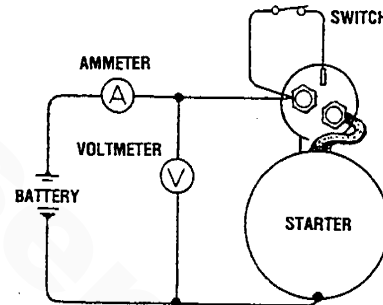

**CAUTION:** Use thick wires as much as possible and tighten every terminal securely. This is a solenoid shift-type starter which makes a rotating sound louder than that of a direct-drive type starter. When detecting starter rotation at the pinion tip, be careful not to come in contact with the pinion gear when it protrudes.

### ADJUSTMENT AND REPAIR

If any abnormality is found by the following tests, the starter should be disassembled and repaired.

#### Pinion Gap Inspection

1. Connect a battery (12V) between the starter terminal "S" and the starter body, and the pinion drive should rotate out and stop.

**CAUTION:** Never apply battery voltage for over 10 seconds continuously.

## STARTER/SOLENOID SERVICE

### SOLENOID

Perform the following tests. If any test result is not satisfactory, replace the solenoid assembly.

1. Disconnect the wire from terminal "M".
2. **Attraction test:** Connect a battery to the solenoid's terminal S for (+) and M for (-). Have a switch in the (+) lead and close it. The pinion drive should extend fully out.

**CAUTION:** Do not apply battery current for more than 10 seconds when testing the solenoid.

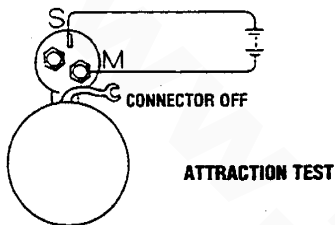

3. **Holding test.** With a battery connected to the solenoid terminal "S" and to the starter body, manually pull out the pinion fully. The pinion must remain at that position even when released from being held by hand.

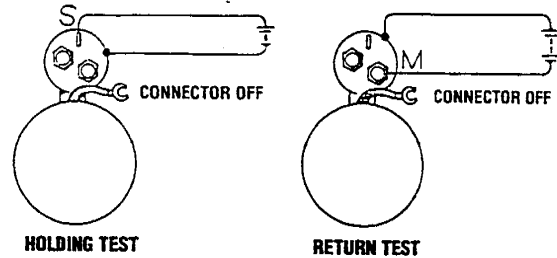

4. **Return test.** With a battery connected to the solenoid terminal "M" and to the starter body, manually pull out the pinion fully. The pinion must return to its original position when released from being held by hand.

### STARTER DISASSEMBLY

1. Disconnect the wire from the solenoid terminal "M".
2. Loosen the two screws fastening the solenoid. Remove the solenoid assembly.
3. Remove the two through bolts and two screws fastening the brush holder. Remove the rear bracket.
4. With the two brushes pulled away from the armature, remove the yoke and brush holder assembly. Then pull the armature out.
5. Remove the cover, pry the snap ring out, and remove the washer.
6. Unscrew the bolts and remove the center bracket. At the same time, the washers for the pinion shaft end play adjustment will come off.
7. Pull out the reduction gear lever and lever spring from the front bracket.
8. On the pinion side, pry the snap ring out, and pull out the pinion and pinion shaft.
9. At each end of the armature, remove the ball bearing with a bearing puller. It is impossible to replace the ball bearing press-fitted in the front bracket. If that bearing has worn off, replace the front bracket assembly.

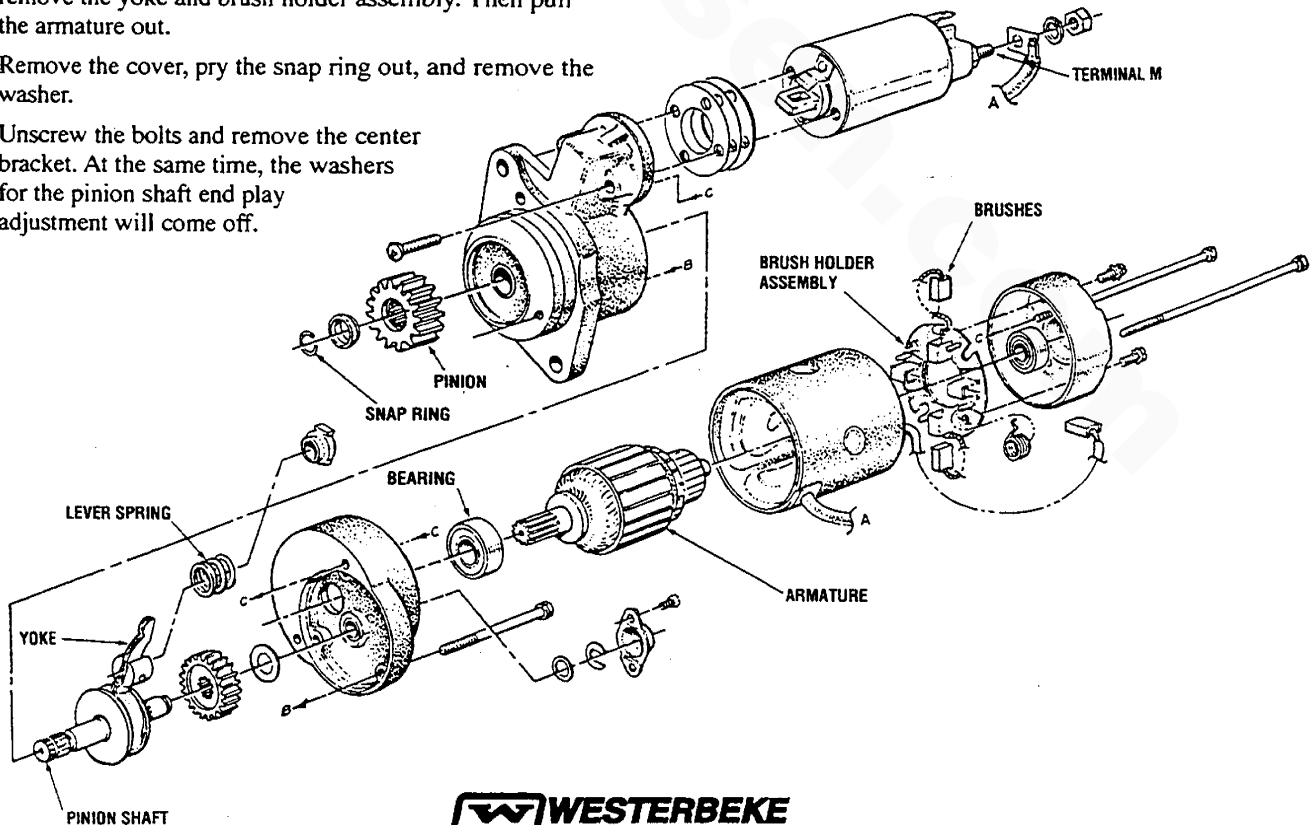

**WESTERBEKE**  
Engines & Generators

## STARTER/SOLENOID SERVICE

### STARTER INSPECTION

#### Solenoid

Inspect the solenoid for continuity between terminals S and M and between terminals S and body. No continuity should be found between S and M. Continuity should be found between S and the body and M and the body.

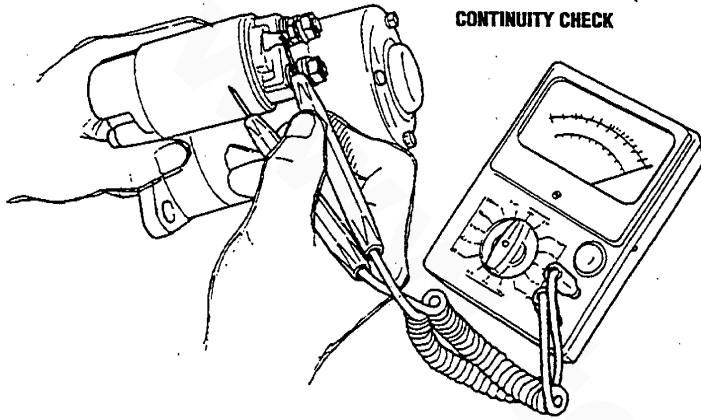

#### Inspecting The Armature

1. Check the armature with a growler tester. If it's short circuited, replace the armature. Also check for insulation between the commutator and its shaft. If poorly insulated, replace the armature.

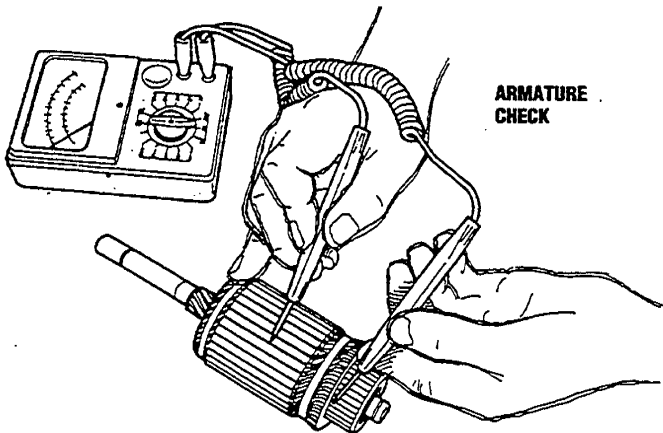

2. Measure the commutator O.D. and the depth of undercut. Repair or replace it if the service limit is exceeded. Also check the commutator outside surface for dirtiness and roughness. If rough, polish the commutator with a fine crocus cloth.

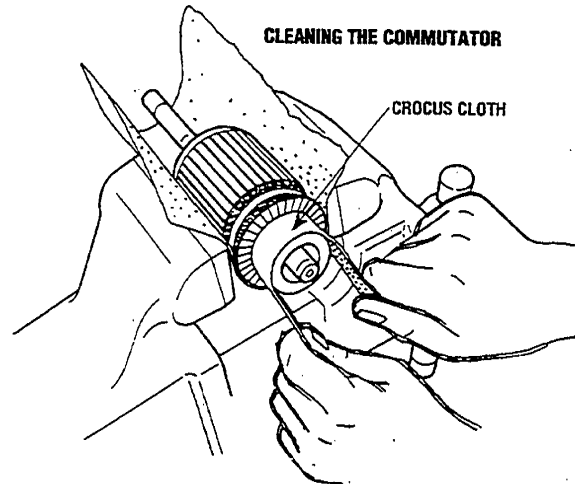
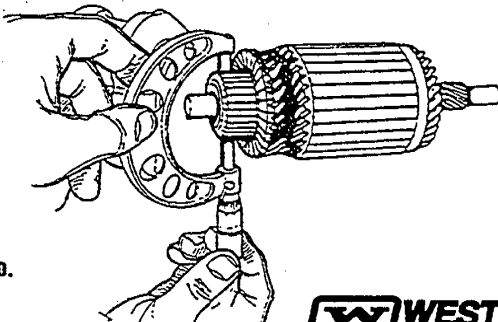

#### Brush and Brush Holder Inspection

1. Check the brushes. If worn out beyond 10 mm, replace the brushes.

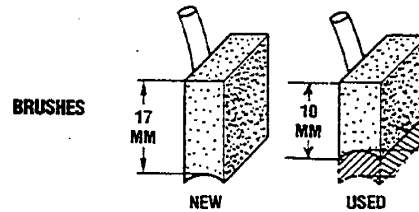

2. Check the brush spring tension. A weak or defective spring will cause excessive brush wear; replace the springs if suspect.

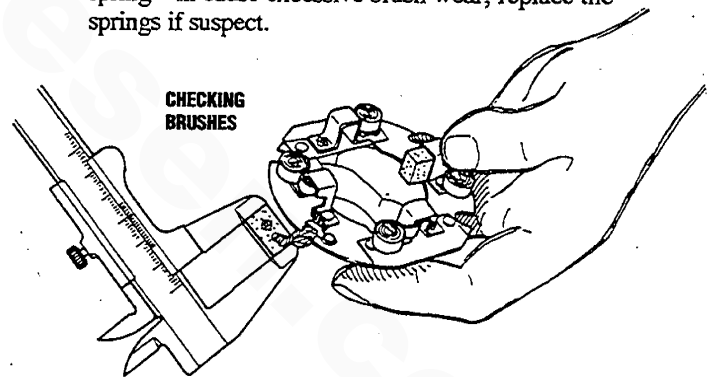

3. Check for insulation between the positive brush holder and holder base. If poorly insulated, replace the holder assembly. Also check the brush holders for proper staking.

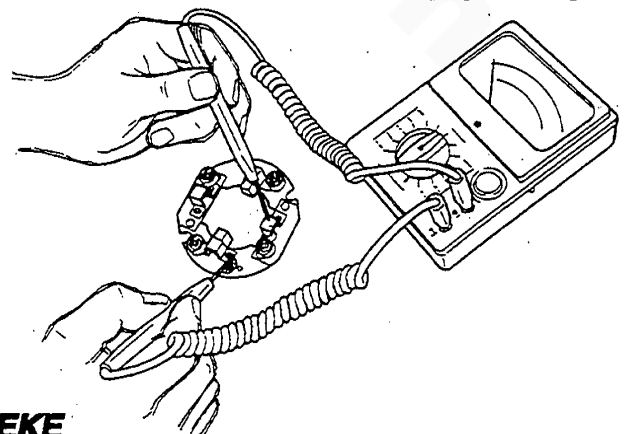

## STARTER/SOLENOID SERVICE

### Field Coil Inspection

1. Check for insulation between one end (brush) of the coil and yoke.
2. Check for continuity between both ends (brushes) of the coil.
3. Check the poles and coil for tightness.

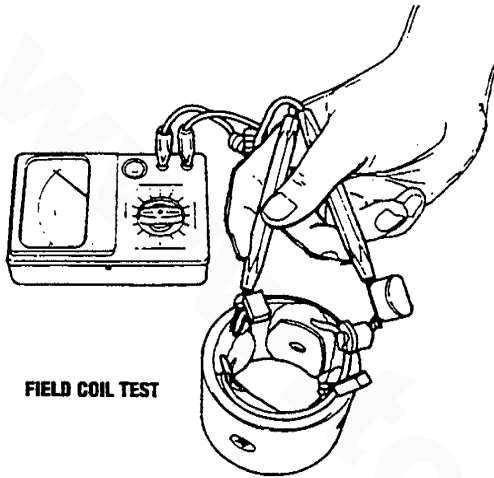

### STARTER ADJUSTMENT AND REASSEMBLY

**CAUTION:** Before installing, thoroughly clean the starter flange and mounting surfaces, remove all oil, old paint, and rust. Starter performance largely depends on the quality of the wiring. Use wire of sufficient size and grade between the battery and starter and fully tighten to the terminal.

Reassemble the starter assembly in the reverse order of disassembly, making sure of the following:

1. **Pinion shaft end play adjustment.** Set the end play (thrust gap) to between 0.5 to 2 mm by inserting an adjusting washer between the center bracket and the reduction gear.
  - a. Fit the pinion shaft, reduction gear washer and snap ring to the center bracket.
  - b. Measure the end play by moving the pinion shaft in the axial direction. If the end play exceeds 0.5 mm, increase the number of adjusting washers inserted.

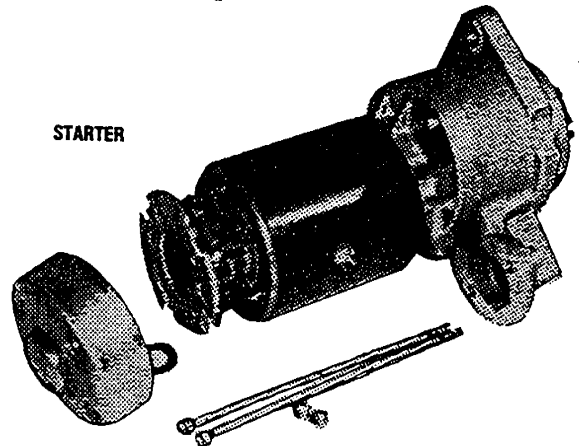

2. **Greasing.** Whenever the starter has been overhauled, apply grease to the following parts:
  - a. Armature shaft gear and reduction gear.
  - b. All bearings.
  - c. Bearing shaft washers and snap rings.
  - d. Bearing sleeves.
  - e. Pinion.
  - f. Sliding portion of lever.

**CAUTION:** Never smear the starter fitting surface, terminals, brushes, or commutator with grease.

3. After reassembly, check by conducting a no-load test again.

## DC ELECTRICAL SYSTEM

### DESCRIPTION

The DC Circuit functions to start, operate and stop the generator's engine. The circuit is best understood by reviewing the *DC ELECTRICAL SYSTEM WIRING DIAGRAMS*.

The engine's DC wiring is designed with three simple basic circuits: *preheat, start, and run or stop*.

### Engine 12-Volt Control Circuit

The engine has a 12 volt DC electrical control circuit that is shown in the wiring diagrams. Refer to these diagrams when troubleshooting or when servicing the DC electrical system on the engine.

**CAUTION:** To avoid damage to the battery charging circuit, never shut off the engine battery switch while the engine is running. Shut off the engine battery switch, however, to avoid electrical shorts when working on the engine's electrical circuit.

### CHARGING SYSTEM

The charging system consists of an alternator, a voltage regulator, an engine DC wiring harness, an engine-mounted DC circuit breaker, a battery and connecting wires. Because of the use of integrated circuits (IC's) the electronic voltage regulator is very compact and is mounted internally or on the back of the alternator.

### ALTERNATOR TROUBLESHOOTING

If you suspect that the alternator is not producing enough voltage to charge the engine's battery, check the following:

**WARNING:** A failed alternator can become very hot. Do not touch until the alternator has cooled down.

- Make certain your alternator is securely mounted.
- Check the drive belts for proper tension.
- Inspect for loose or disconnected wires at the alternator.

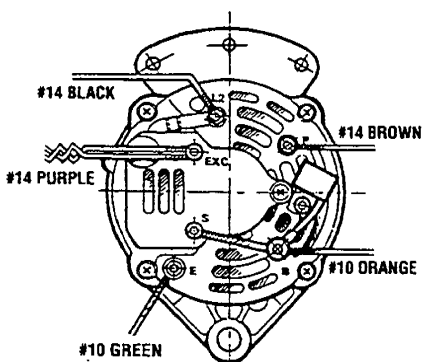

MANDO  
51 AMP ALTERNATOR

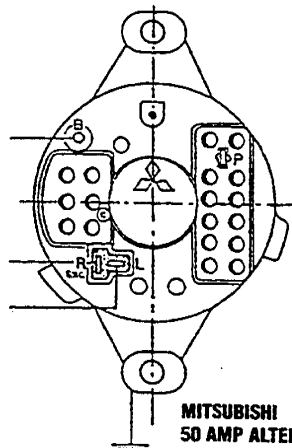

MITSUBISHI  
50 AMP ALTERNATOR

**NOTE:** An isolator with a diode, a solenoid, or a battery selector switch is usually mounted in the circuit to isolate the batteries so the starting battery is not discharged along with the house batteries. If the isolator is charging the starting battery but not the house battery, the alternator is OK and the problem is in the battery charging circuit.

**WARNING:** Shut off the engine battery switch or disconnect from the battery when working on the engine electrical system.

### Checking for Proper Voltage

If you suspect the alternator has failed, perform the following tests with the engine off:

1. Using a voltmeter, connect the voltmeter red wire clip to the output terminal B.
2. Connect the voltmeter negative wire to any ground on the engine.
3. Check the battery voltage. If the battery is in good condition it should read 12 to 12.5 volts.
4. Check the voltage between the alternator (+) positive terminal B and any engine ground. If the circuit is good, the voltage at the alternator should be the same as the battery (unless there's an isolator in the circuit, then the reading would be zero).

**CAUTION:** To avoid damage to the battery charging circuit, never shut off the engine battery switch when the engine is running!

**WARNING:** Before starting the engine make certain that everyone is clear of moving parts! Keep away from sheaves and belts during test procedures.

5. Start the engine.
6. The voltage reading for a properly operating alternator should indicate between 13.5 and 14.5 volts. If your alternator is over- or undercharging, have it repaired at a reliable service shop.

**NOTE:** Before removing the alternator for repair, use your voltmeter to ensure that 12 volts DC excitation is present at the EXC terminal if the previous test showed only battery voltage at the B output terminal.





## DC ELECTRICAL SYSTEM

### BATTERY MAINTENANCE

Review the manufacturer's recommendations and then establish a systematic maintenance schedule for your engine's starting batteries and house batteries.

- Monitor your voltmeter for proper charging during engine operation.
- Check the electrolyte level and specific gravity with a hydrometer.
- Use only distilled water to bring electrolytes to a proper level.
- Make certain that battery cable connections are clean and tight to the battery posts (and to your engine).
- Keep your batteries clean and free of corrosion.

**⚠ WARNING:** Sulfuric acid in lead batteries can cause severe burns on skin and damage clothing. Wear protective gear.

### GLOW PLUGS

The glow plug is a small heater installed in each pre-combustion chamber. They run off the engine starting battery and become red hot when activated.

The glow plugs are wired through the preheat solenoid. When PREHEAT is pressed at the control panel this solenoid should "click" on and the glow plug should begin to get hot.

Glow plugs can be checked by unscrewing and holding them against a good ground (engine block) and turning them on. The tip should glow red hot. You can also use an ammeter to test the power drain (8 to 9 amps per plug) or an ohmmeter to test resistance (1.1 to 1.2 ohms).

**⚠ WARNING:** These glow plugs will become very hot to the touch. Be careful not to burn your fingers when testing plugs.

Reinstall the plugs in the engine and test them again. The plugs should get very hot (at the terminal end) within 20 to 25 seconds. If the plugs don't heat up quickly, check for a short circuit.

When installing the glow plugs, use anti-seize compound on the threads.

**⚠ CAUTION:** Do not keep glow plugs on for more than 30 seconds.

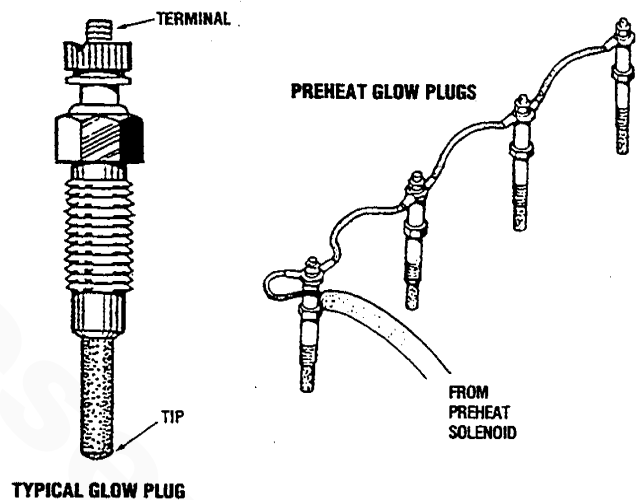

## ALTERNATOR/REGULATOR SERVICE

### DESCRIPTION

The alternator serves to keep the battery constantly charged. It is driven from the pulley at the end of the crankshaft by a V-belt. The type of alternator used is ideal for high speed engines having a wide range of engine speeds. It contains diodes that convert AC to DC, and an IC regulator that keeps the generated voltage constant even when the engine speed changes.

**CAUTION:** Do not use any high-voltage tester such as a megger. Otherwise, damage to diodes will result.

During high-speed running of the engine, do not disconnect the positive or negative terminal of the battery from terminal B of the alternator. If this is done, diode failure will result.

With alternators having IC regulators, absolutely avoid a short circuit between terminals B and L. This would allow current to flow in the "diode trio" and damage it.

Do not start the engine with the lead disconnected from terminal B of the alternator. Otherwise, damage to the voltage regulator will result.

When charging the battery with a quick charger, be sure to disconnect the battery terminals to prevent damage to diodes.

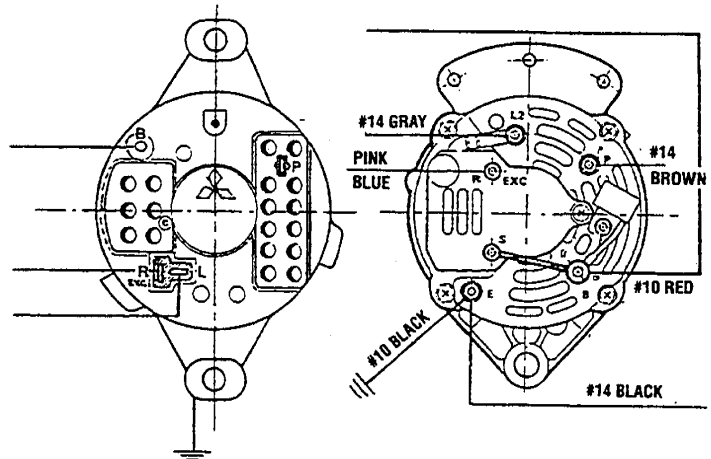

### ALTERNATOR TROUBLESHOOTING

If you suspect that the alternator is not producing enough voltage to charge the engine's battery, check the following:

- Make certain your alternator is securely mounted.
- Check the drive belts for proper tension.
- Inspect for loose or disconnected wires at the alternator

**WARNING:** A failed alternator can become very hot. Do not touch until the alternator has cooled down.

### Testing The Charging Voltage

If you suspect the alternator has failed, perform the following tests.

1. Using a voltmeter, connect the voltmeter red wire clip to the output terminal B.
2. Connect the other voltmeter wire to any ground on the engine.
3. Start the engine and record the voltmeter's readings.

**CAUTION:** To avoid damage to the battery charging circuit, never shut off the engine battery switch when the engine is running!

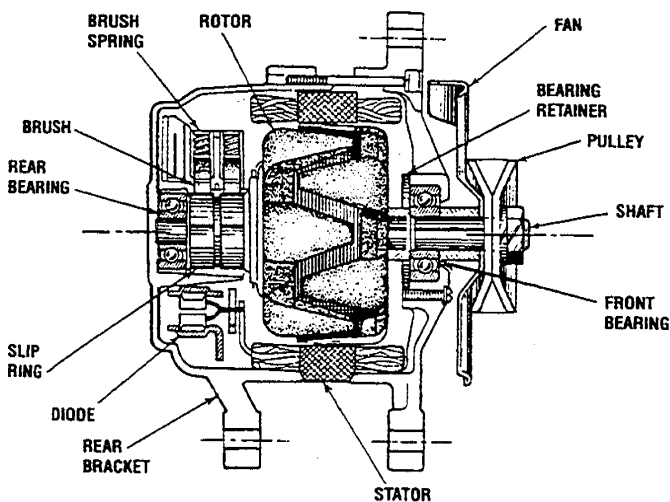

## ALTERNATOR/REGULATOR SERVICE

The voltage reading for a properly operating alternator should be between 13.5 and 14.5 volts. If your alternator is over- or undercharging, have it repaired at a reliable service shop, or continue with the following tests.

**NOTE:** Before removing the alternator for repair, use your voltmeter to ensure that 12 volts DC excitation is present at the R (EXC) terminal if the previous test showed only battery voltage at the B output terminal.

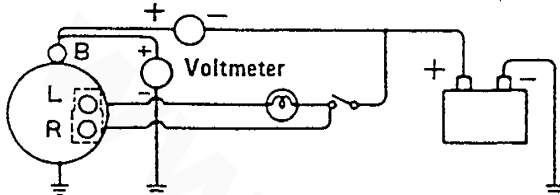

### Output Test

1. Disconnect the battery ground cable.
2. Disconnect the wire from terminal B on the alternator and connect an ammeter between B and this wire.
3. Connect a voltmeter between terminal B (+) and ground (-).
4. Connect to the P terminal.
5. Reconnect the battery ground cable to the (-) terminal. The voltmeter should indicate the battery voltage.
6. Connect B+ to the R terminal (regulator).
7. Start the engine.
8. Turn on 12 volt accessories equaling the amperage output of the alternator, accelerate the engine to the specified speed (2000 to 3000 rpm) and measure the output current. The output current should be close to the alternator's maximum output.

Output Current	1300 rpm	2500 rpm	5000 rpm
Hot	16 amp	41 amp	48 amp
Cold	24 amp	50 amp	-

**NOTE:** rpm is that of the alternator. The pulley ratio (alternator vs crank pulley) is 1.78 to 1; all readings are at 13.5 volts.

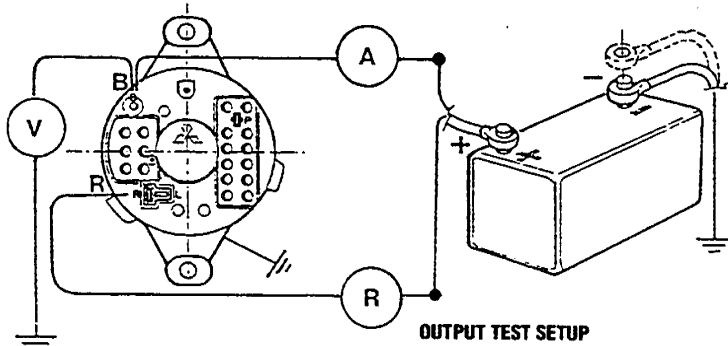

### DISASSEMBLY

1. After removing the three assembly through-bolts, insert a screwdriver between the front bracket and stator. While prying it, remove the front bracket and rotor.

**NOTE:** If the screwdriver is inserted too deep, the stator coil might be damaged.

2. Hold the rotor in a vise and remove the pulley nut. Then remove the pulley, fan, spacer and seal. Next, remove the rotor from the front bracket and remove the seal.
3. Unsolder the rectifier from the stator coil lead wires and remove the stator assembly.

**NOTE:** Make sure that the solder is removed quickly (in less than five seconds). If a diode is heated to more than 150°C (310°F), it might be damaged.

4. Remove the condenser from terminal B.
5. Unsolder the plates B and L from the rectifier assembly.
6. Remove the mounting screw and B terminal bolt and remove the electronic voltage regulator and brush holder. The regulator and brush holder cannot be separated.
7. Remove the rectifier assembly.
8. Brush and brush spring replacement:

When only a brush or brush spring is to be replaced, it can be replaced without removing the stator, etc. With the brush holder assembly removed, unsolder the pigtail of the brush.

**NOTE:** If the terminals L and B of the rectifier assembly are bent, damage might result to the rectifier. Therefore, the plates B and L should be gently bent at the center.

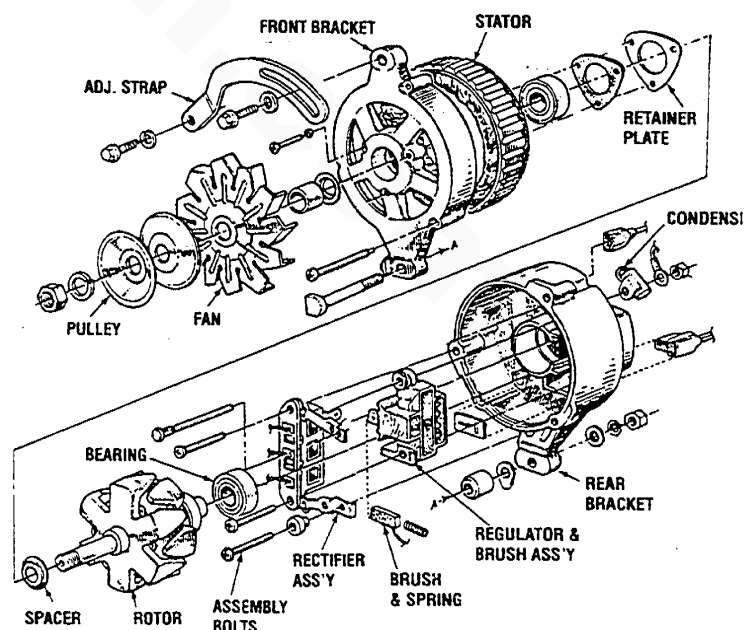
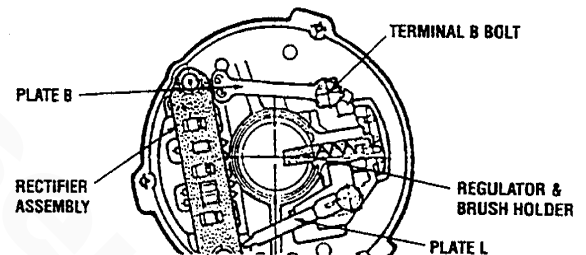

## ALTERNATOR/REGULATOR SERVICE

An alternate method for removing the stator winding, brush holder regulator unit and the I.C. diode rectifier assembly from the rear bracket. With the front bracket and rotor assembly separated from the rear half of the alternator:

1. Insert a flat-bladed screwdriver between the stator core and the edge of the rear bracket on the same side as the brush-holder. Raise this side of the stator core away from the bracket so as to open a gap of about 1/2 inch.

**NOTE:** Be careful not to allow the screwdriver blade to enter far enough to touch the stator winding.

2. Maintaining the 1/2 inch gap, insert the screwdriver between the stator core and the bracket on the rectifier side and move the stator laterally toward the brush-holder for a distance of 1/2 to 3/4 of an inch without lifting it from the bracket.
3. Insert a #2 Phillips screwdriver through this opening and remove the two screws holding the rectifier.

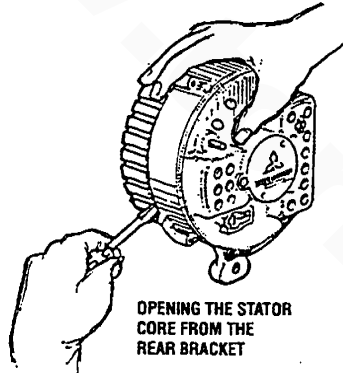
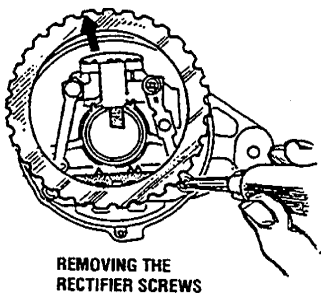

4. Remove the nut anchoring the B terminal bolt and the capacitor mounted thereto on the outside rear of the bracket. Then remove the third Phillips screw holding the brush holder to the bracket.
5. Carefully withdraw stator, brush holder and rectifier from the rear bracket as one loosely connected unit.

With the bracket out of the way, it is easy to unsolder the stator winding leads from the rectifier quickly to avoid heat damage to the diodes and I.C. chips. It is also easier to renew the brushes because there is no need to bend the connecting plates between the brush holder and the rectifier and possibly damage the rectifier.

When reversing this procedure, make sure that the stator winding leads are gently pushed back (from possible contact with the rotor body) after seating the stator into the rear bracket.

### INSPECTION

#### Diode

Diode troubles are classified as open-circuit and short-circuit. When the diode is open-circuited, no current flows. In the short-circuited diode, current flows in both directions.

#### Checking for Short Circuit

Check for continuity between the (+) heat sink and the stator coil lead joint terminal and between the (-) heat sink and the said terminal. If each test shows current flow in both directions, the diodes are short-circuited. Replace the rectifier assembly.

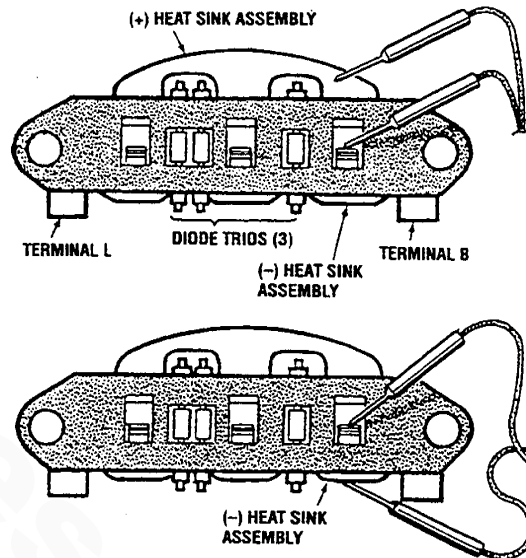

#### Checking for Open Circuit

To check for an open circuit in the diodes which have passed the short-circuit test, disconnect the diode leads and check with your ohmmeter between the diode lead and the body, reversing the leads. If no continuity is found, the diode is open.

#### Checking Diode Trio

Check each of the three diodes for continuity. If any diode allows current flow in both directions or does not allow current to flow in one direction, replace the rectifier assembly.

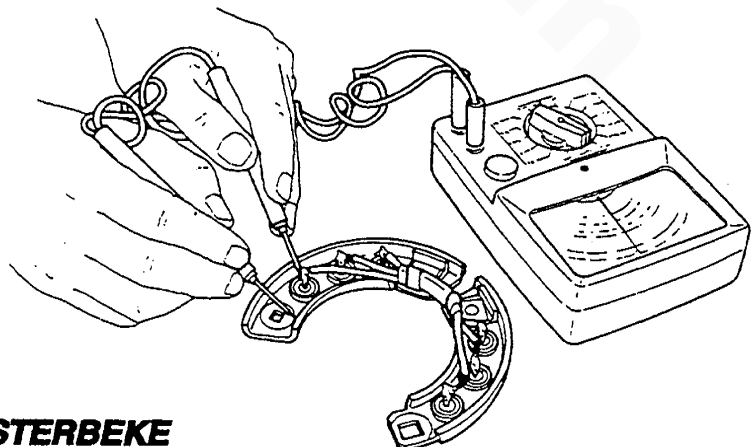

## ALTERNATOR/REGULATOR SERVICE

### Stator

Disconnect the stator lead wires from the coil and check for continuity between the three leads with a circuit tester. If no continuity is found, the stator windings are open. Next, check for insulation between each lead and the core. If continuity is found, replace the stator.

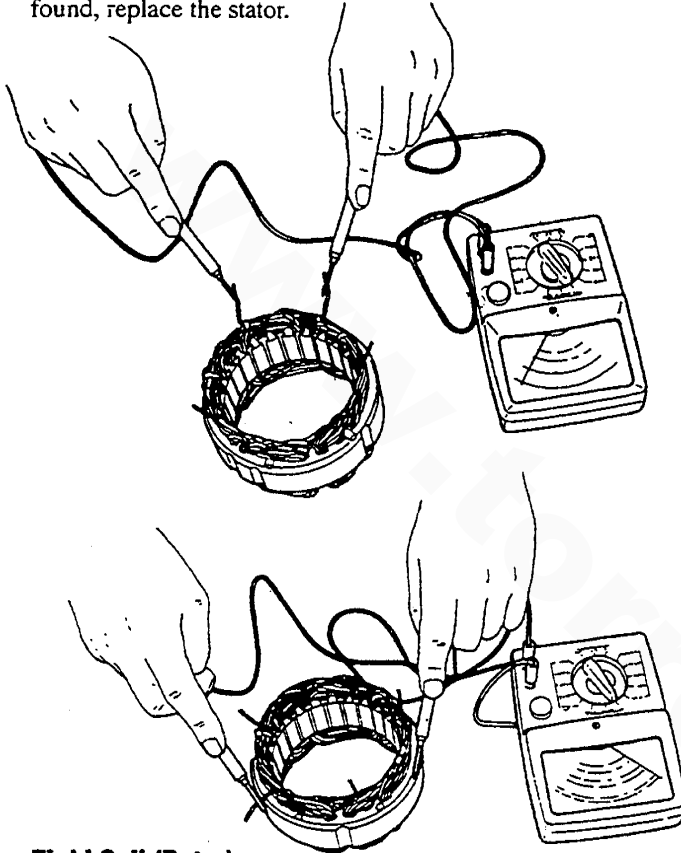

### Field Coil (Rotor)

Check resistance between the slip rings. The resistance must conform to the specified value.

Resistance Value:  $3.87\Omega \pm 10\%$

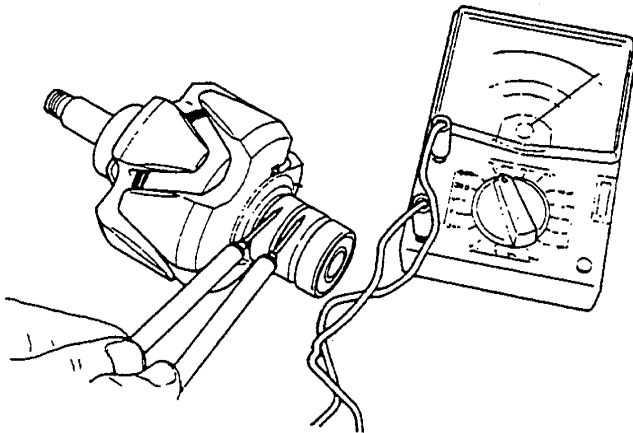

Check for continuity between the slip ring and the core. If there is continuity, it means that the coil or slip ring is grounded. Replace the rotor assembly.

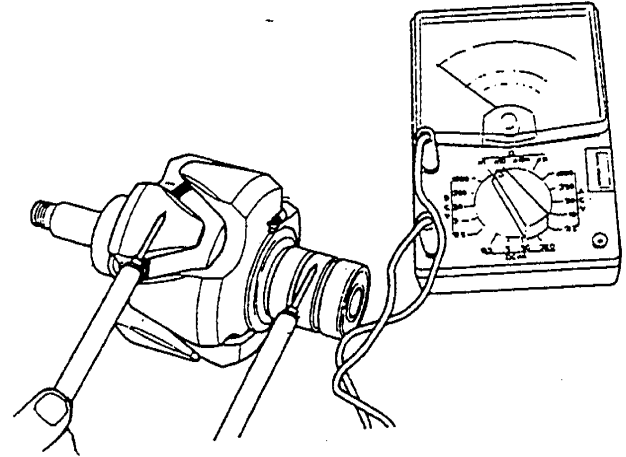

### Checking Brush and Brush Spring

Replace the brush if it has worn to the replacement value. Check the brush spring force. Also confirm that the brush moves smoothly in the brush holder.

	Standard Value	Replacement Required at
Brush Length (mm)	18	8
Brush Spring Force (g)	370 <sup>+60</sup>	210

### Checking the Slip Ring

Because the slip ring wears very little, the diameter must be measured with a micrometer. Replace the rings (rotor assembly) when wear reaches the replacement value.

	Standard Value	Replacement Required at
Slip Ring O.D.	33 mm	32.2 mm
Runout	0.03 mm or less	0.2 mm

The slip ring must be smooth with no surface oil. If necessary clean and polish with a fine crocus cloth.

### REGULATOR

The regulator consists of a voltage regulator and a lamp relay; their wires are gathered into a connector. The voltage regulator is used to always keep the alternator output constant regardless of alternator speed and to cut off the flow of current to the field coil when necessary. The lamp relay is used on the Captain panel only to illuminate the panel light indicating no alternator charge. The 50A alternator has a built-in IC regulator. During alternator operation, field current is controlled automatically by the IC regulator.

1. Connect an ammeter (approx. 60A rating) between the battery positive terminal and its cable.
2. Connect a voltmeter between the generator terminal L and the ground. In this case, the voltmeter must indicate "O". If otherwise indicated, a defective alternator or faulty wiring is suspected.

## ALTERNATOR/REGULATOR SERVICE

- Turn the starting switch key to the ON position, and the voltmeter will indicate a value considerably lower than the battery voltage. If the indication is near the battery voltage, a defective generator is possible.
- With the ammeter short-circuited, start the engine.

**CAUTION:** If the ammeter is not short-circuited, a large starting current will burn out the ammeter coil.

- Increase the engine speed to between 2000 and 3000 rpm and read the ammeter.
- If the ammeter reading does not exceed 5A, read the voltmeter at that state (2000–3000 rpm). The voltmeter reading is the regulated voltage.
- If the ammeter reading exceeds 5A, continue charging the battery until the ammeter reading drops to 5A or below; or replace the battery with a fully-charged one; or connect a  $1/4\Omega$  (25W) resistor in series to the battery to restrict charging current.
- The IC regulator is of the temperature compensation type and, therefore, regulated voltage varies with temperature. It is necessary to measure the temperature of the rear bracket (surrounding the regulator) and to use the measurement for correction of regulated voltage.

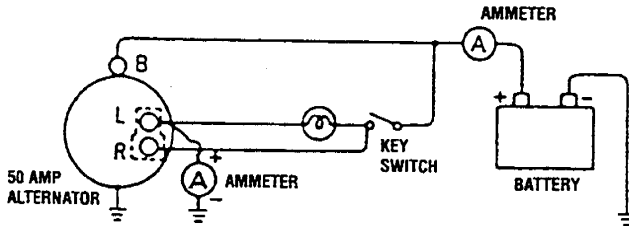

CHECKING THE IC REGULATOR VOLTAGE

### REASSEMBLY

**CAUTION:** Connect the alternator properly. Should the polarity be reversed, a powerful current would flow from the battery into the alternator, damaging the diodes and wiring harness.

- Install the alternator support bolt through the alternator leg (underside) into the engine casting.
- Swing the alternator into position on the adjusting bracket and fasten. Lightly tighten.
- Adjust belt tension.
- Tighten both bolts and recheck belt tension.

Torque values:

Support bolt: 20 – 24 Nm (15 – 18 ft-lbs)

Adjusting bracket bolt: 12 – 14 Nm (9 – 10 ft-lbs)

**NOTE:** Make certain the belts are perfectly aligned with the alternator and engine pulleys. If not, insert or remove spacers as needed, to align the alternator.

## TRANSMISSIONS

WESTERBEKE uses a variety of marine transmissions made by well-known marine manufacturers such as *HURTH*, *ZF*, *BORG WARNER*, *PARAGON* and others. If you require transmission parts, repair work or an overhaul, we recommend contacting the transmission manufacturer directly for information on the locations of authorized service facilities.

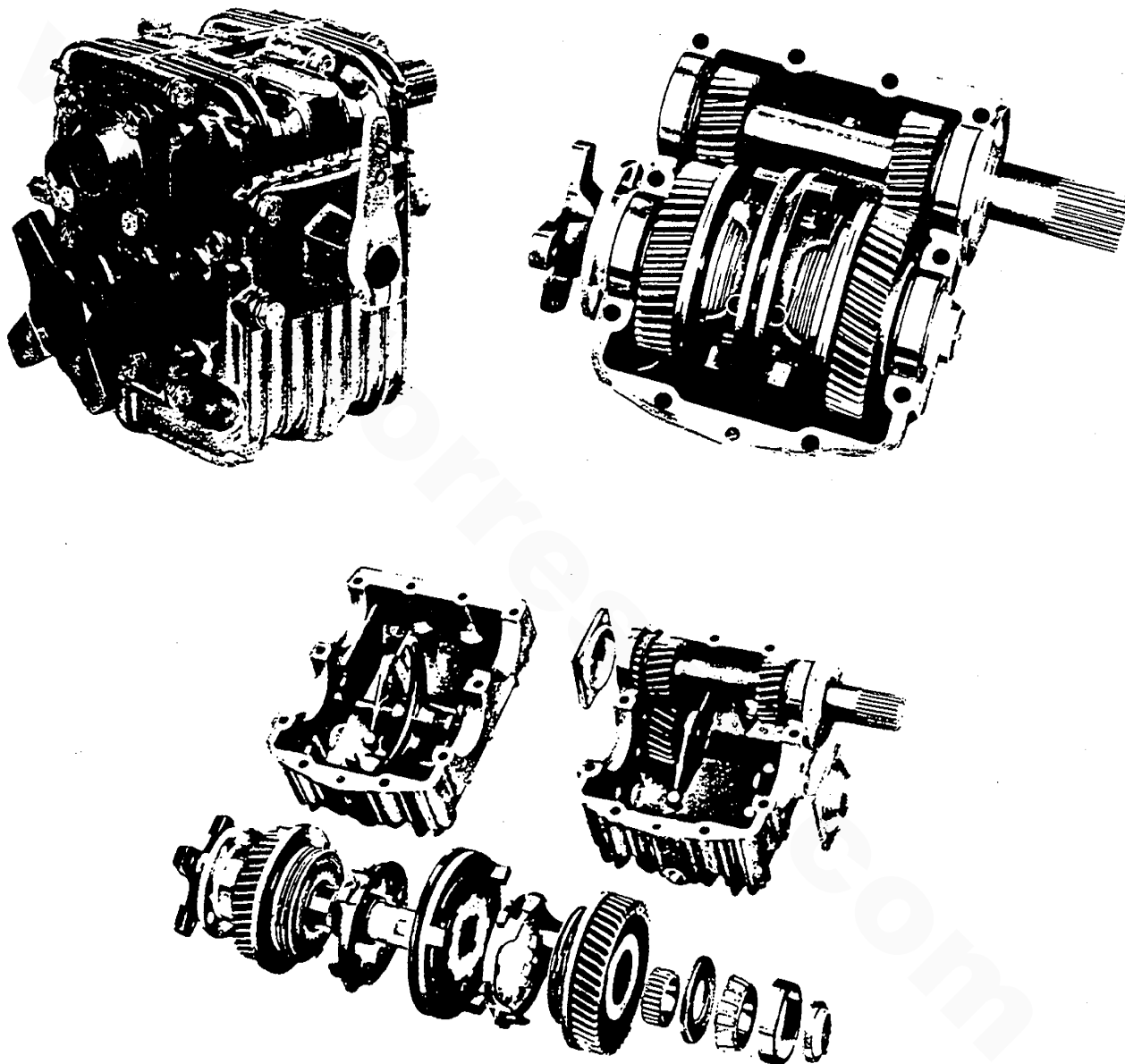

# DC ELECTRICAL SYSTEM

## ENGINE WIRING DIAGRAM #24666

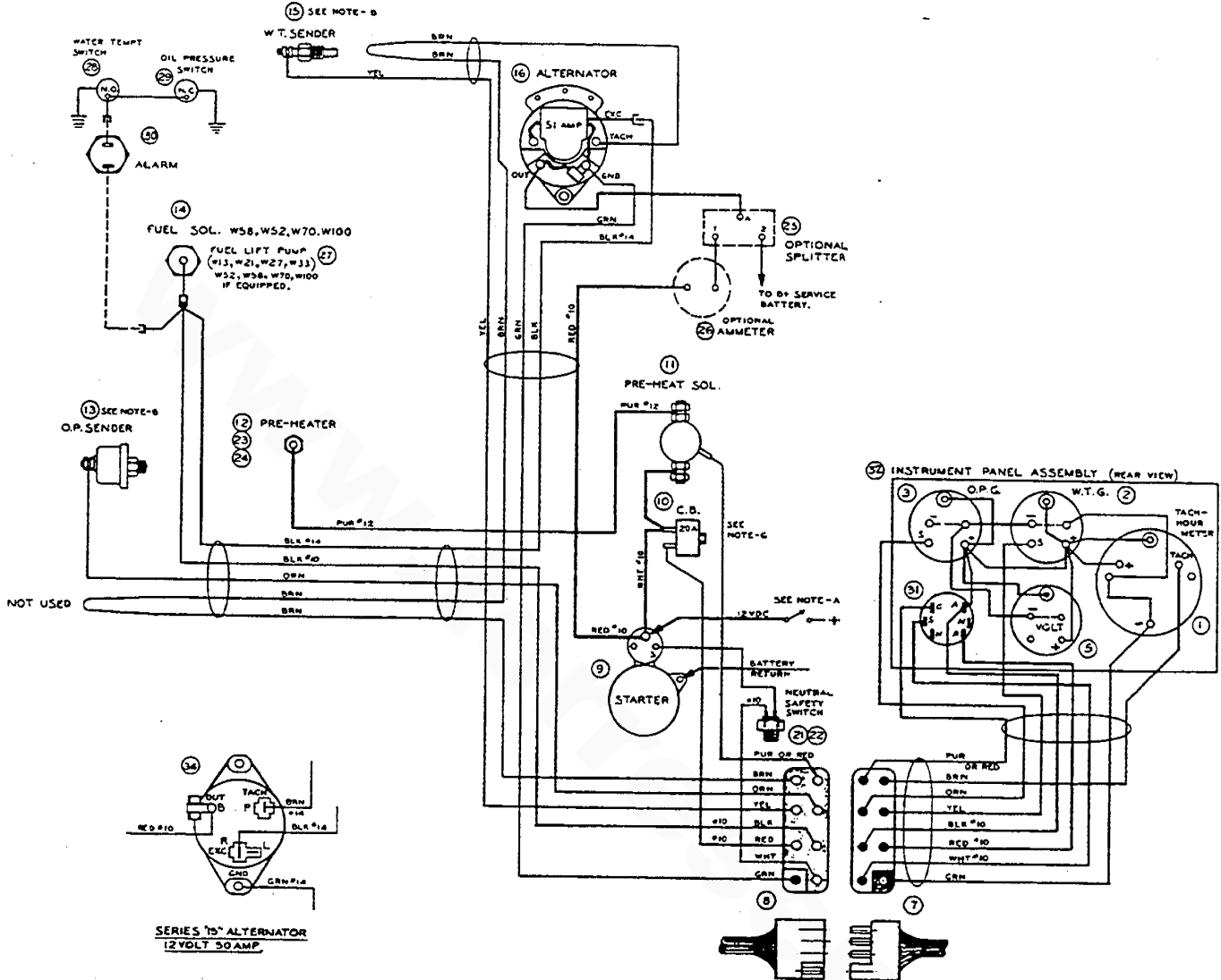

34	30594	ALTERNATOR, 12V. 50A.	1		
33	24951	PANEL, LESS INSTRUMENTS	1		
32	24880	PANEL, COMPLETE	1	1	
31	24777	KEY SWITCH	1		
30	13355	ALARM	1		
29	30944	OIL PRESS. SW. N.C.	1		
28	30125	WATER TEMPT. SW. N.O.	1		
27	24831	FUEL LIFT PUMP	1		
26	11381	AMMETER (OPTIONAL)	1		
25	20634	SPLITTER (OPTIONAL)	1		
24	14529	GLOW PLUGS W30E W60AERN	1		
23	11530	GLOW PLUGS W40	1		
22	2	NEUTRAL SAFETY SW. PARAGCH	1		
21	23433	NEUTRAL SAFETY SW. WARREN	1		
20	24628	PANEL, LESS INSTRUMENTS	1		
19	24660	PANEL, COMPLETE	1	1	
18	11532	SUPPRESSION KIT. ALT.	1		
17	12959	TACH. KIT. ALTERNATOR	1		
16	24684	ALTERNATOR, 51 A.	1		
15	23571	SENDER, WATER TEMP.	1		
14	24359	SOLENOID, FUEL	1		
13	24132	SENDER, OIL PRESSURE	1		
12	24353	PRE-HEATER (W38)	4		
11	24635	SOLENOID, PRE-HEAT	1		
10	24683	CIRCUIT BREAKER 20AMP	1		
9	16762	STARTER, MARINE ENGINE	1		
8	30092	HARNES. ENGINE	1		
7	30148	HARNES. PANEL	1		
6	11956	KEYSWITCH	1		
5	23090	VOLTMETER	1		
4	11957	SWITCH, PRE-HEAT	1		
3	24133	OIL PRESSURE GAUGE	1		
2	11545	WATER TEMP. GAUGE	1		
1	11917	TACHOMETER	1		
ITEM	PART NO.	DESCRIPTION	QTY	ASSY	OPTION ASSY





# DC ELECTRICAL SYSTEM

## ENGINE WIRING SCHEMATIC #24666

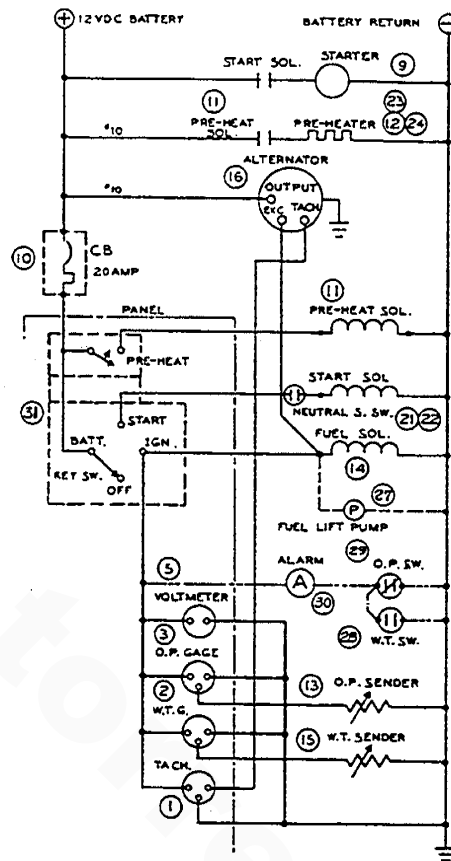

### NOTES:

#### NOTES ON BUILDER/OWNERS RESPONSIBILITY.

- (A) AN ON-OFF SWITCH MUST BE INSTALLED IN THIS LINE TO DISCONNECT THE STARTER CIRCUIT FROM THE BATTERY IN AN EMERGENCY & WHEN LEAVING THE BOAT. 12 VOLT DIESEL ENGINE STARTERS TYPICALLY DRAW 200 TO 300 AMPS WHEN CRANKING. THE DURATION OF INDIVIDUAL CRANKING CYCLES SHOULD NOT EXCEED 30 SECONDS. A SWITCH WITH CONTINUOUS RATING OF 175 AMPS AT 12VDC WILL NORMALLY SERVE THESE FUNCTIONS, BUT SUCH A SWITCH MUST NEVER BE USED TO "MAKE" THE STARTER CIRCUIT.

#### OTHER NOTES\*

- (B) WARNING; SENDER CONNECTION: CONTACT WITH B+ MAY DAMAGE SENDER.
- (C) ALL RETURNS ARE THROUGH ENGINE BLOCK.
- (D) FOR WIRING OF AUXILIARY ALTERNATORS SEE THE FOLLOWING DIAGRAMS  
 MOTOROLA 60 AMP, 11232  
 MOTOROLA 120 AMP, 11231  
 LEECE-NEVILLE 53 AMP, 16335  
 LEECE-NEVILLE 105 AMP, 16619
- (E) IF ADDITIONAL PRESSURE SWITCHES ARE REQ'D TO START BOAT ACCESSORIES, A FLEXIBLE HOSE MUST BE RUN FROM THE OIL PRESSURE MANIFOLD TO A NEARBY BULKHEAD AND ALL PRESSURE SWITCHES MOUNTED AT THE BULKHEAD.
- (F) APPLY SILASTIC OR TIGHT WOUND PLASTIC/SPLICE ELECTRICAL TAPE AROUND CONNECTORS CONNECTED.
- (G) CAUTION:  
 THIS PRODUCT IS PROTECTED BY A MANUAL RESET CIRCUIT BREAKER LOCATED NEAR THE STARTER AND AS CLOSE TO THE SOURCE OF CURRENT AS POSSIBLE. EXCESSIVE CURRENT DRAIN ANYWHERE IN THE INSTRUMENT PANEL, WIRING, OR ENGINE WILL CAUSE THE BREAKER TO TRIP. IN THIS EVENT, MOST ENGINE MODELS WILL SHUT DOWN BECAUSE THE OPENED BREAKER DISCONNECTS THEIR FUEL SUPPLY. THEREFORE THE BUILDER/OWNER MUST BE SURE THAT THE INSTRUMENT PANEL, WIRING AND ENGINE ARE INSTALLED TO PREVENT CONTACT BETWEEN ELECTRICAL DEVICES AND SALT WATER.
- (H) ITEMS A, C, 19 & 20 WERE USED WITH PREVIOUS DESIGN.



# DC ELECTRICAL SYSTEM

## ENGINE WIRING DIAGRAM #33685

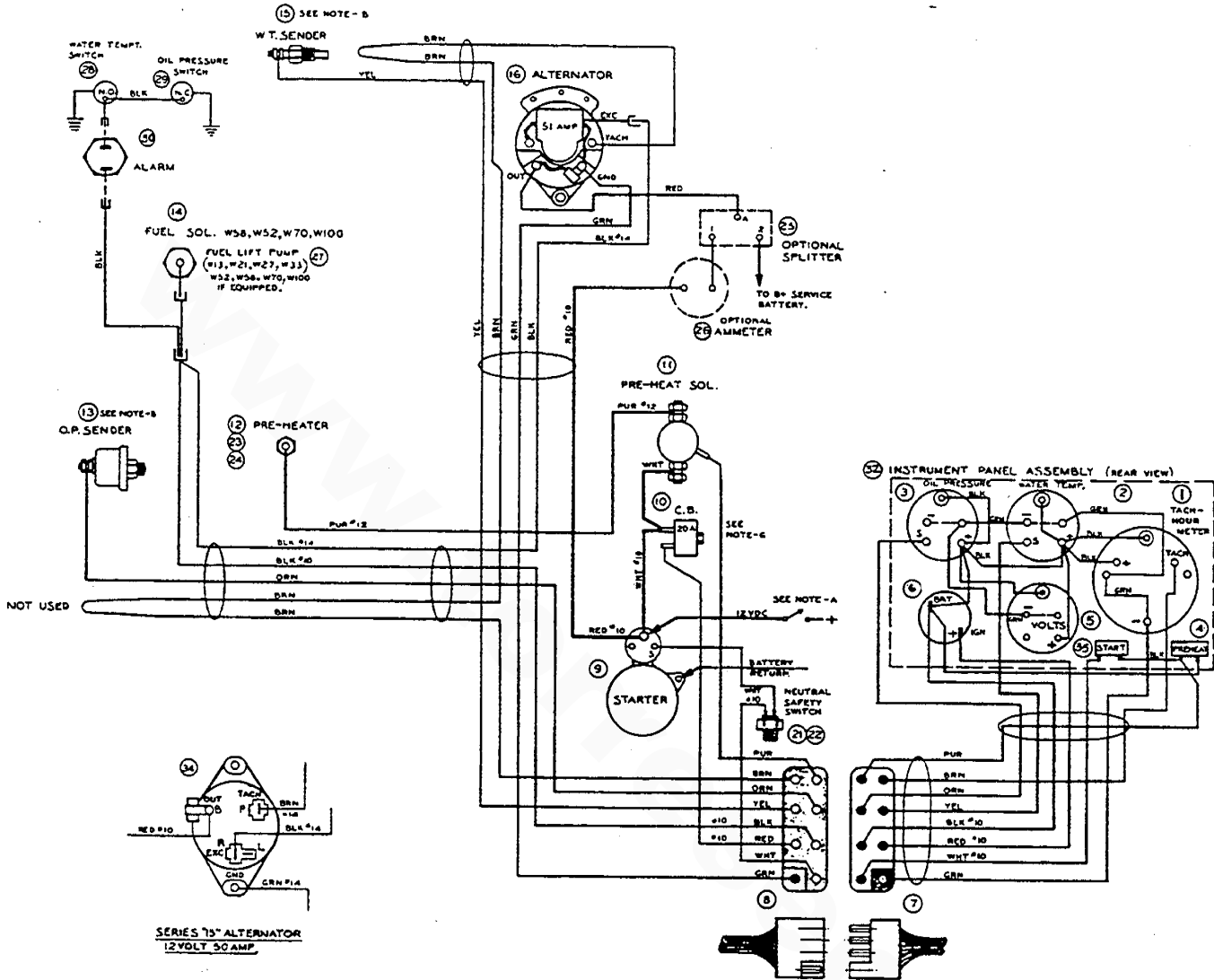

35	33764	SWITCH, START.	1		
34	30594	ALTERNATOR, 12V. 50A.	1		
33	33865	PANEL, LESS INSTRUMENTS	1		
32	33866	PANEL, COMPLETE	1		
31			1		
30	13355	ALARM			1
29	30944	OIL PRESS. SW. N.G.			1
28	30125	WATER TEMP. SW. N.O.			1
27	24831	FUEL LIFT PUMP	1		
26	11581	AMMETER (OPTIONAL)			1
25	20654	SPLITTER (OPTIONAL)			1
24	14529	GLOW PLUGS W30 E W50 AERK			4
23	11530	GLOW PLUGS W40			1
22		NEUTRAL SAFETY SW. PARAGON			1
21	23433	NEUTRAL SAFETY SW. WARNER			1
20		PANEL, LESS INSTRUMENTS	1		
19		PANEL, COMPLETE	1		1
18	11532	SUPPRESSION KIT. ALT.	1		
17	12959	TACH. KIT. ALTERNATOR	1		
16	24684	ALTERNATOR, 51 A.	1		
15	23571	SENDER, WATER TEMP.	1		
14	24330	SOLENOID, FUEL	1		
13	24132	SENDER, OIL PRESSURE	1		
12	24359	PRE-HEATER (W38)	4		
11	24639	SOLENOID, PRE-HEAT	1		
10	24683	CIRCUIT BREAKER 20AMP	1		
9	16762	STARTER, MARINE ENGINE	1		
8	30092	HARNES, ENGINE			1
7	30148	HARNES, PANEL			1
6	33653	KEY SWITCH, IGNITION	1		
5	23090	VOLTMETER	1		
4	33764	SWITCH, PRE-HEAT	1		
3	24133	OIL PRESSURE GAUGE	1		
2	11545	WATER TEMP. GAUGE	1		
1	11917	TACHOMETER	1		
ITEM	PART NO.	DESCRIPTION	QTY	ASSY	OPTION



# DC ELECTRICAL SYSTEM

## ENGINE WIRING SCHEMATIC #33685

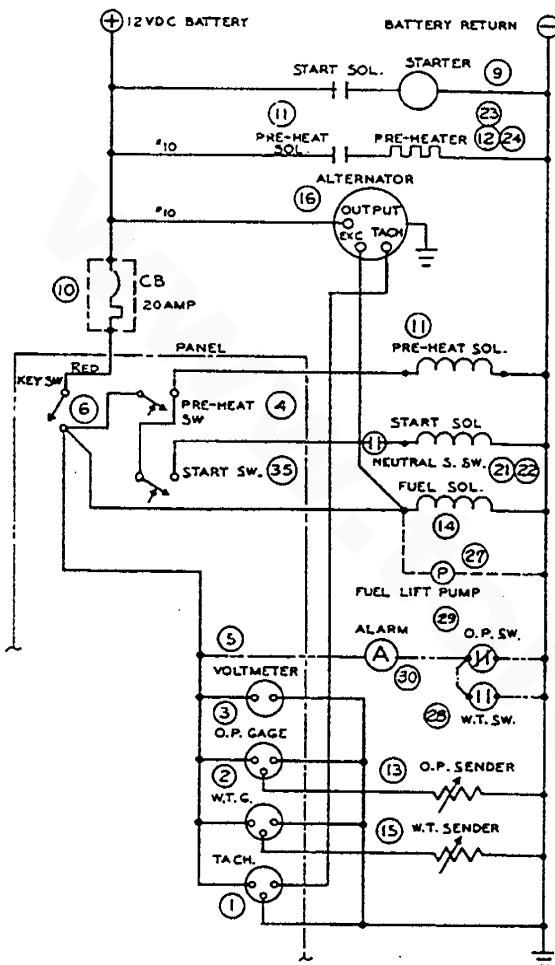

### NOTES:

#### NOTES ON BUILDER/OWNER'S RESPONSIBILITY.

- (A) AN ON-OFF SWITCH MUST BE INSTALLED IN THIS LINE TO DISCONNECT THE STARTER CIRCUIT FROM THE BATTERY IN AN EMERGENCY. WHEN LEAVING THE BOAT, 12VOLT DIESEL ENGINE STARTERS TYPICALLY DRAW 200 TO 300 AMPS WHEN CRANKING. THE DURATION OF INDIVIDUAL CRANKING CYCLES SHOULD NOT EXCEED 30 SECONDS. A SWITCH WITH CONTINUOUS RATING OF 175 AMPS AT 12 VDC WILL NORMALLY SERVE THESE FUNCTIONS, BUT SUCH A SWITCH MUST NEVER BE USED TO "MAKE" THE STARTER CIRCUIT.

#### OTHER NOTES:

- (B) WARNING ; SENDER CONNECTION: CONTACT WITH B+ MAY DAMAGE SENDER.
- (C) ALL RETURNS ARE THROUGH ENGINE BLOCK.
- (D) FOR WIRING OF AUXILIARY ALTERNATORS SEE THE FOLLOWING DIAGRAMS.  
 MOTOROLA 65 AMP, 11232  
 MOTOROLA 120 AMP, 11231  
 LEECE-NEVILLE 53 AMP, 16535  
 LEECE-NEVILLE 105 AMP, 16614
- (E) IF ADDITIONAL PRESSURE SWITCHES ARE REQ'D TO START BOAT ACCESSORIES, A FLEXIBLE HOSE MUST BE RUN FROM THE OIL PRESSURE MANIFOLD TO A NEARBY BULKHEAD AND ALL PRESSURE SWITCHES MOUNTED AT THE BULKHEAD.
- (F) APPLY SILASTIC OR TIGHT WOUND PLASTIC/SPlice ELECTRICAL TAPE AROUND CONNECTORS CONNECTED.
- (G) CAUTION:  
THIS PRODUCT IS PROTECTED BY A MANUAL RESET CIRCUIT BREAKER LOCATED NEAR THE STARTER AND AS CLOSE TO THE SOURCE OF CURRENT AS POSSIBLE. EXCESSIVE CURRENT DRAIN ANYWHERE IN THE INSTRUMENT PANEL, WIRING, OR ENGINE WILL CAUSE THE BREAKER TO TRIP. IN THIS EVENT, MOST ENGINE MODELS WILL SHUT DOWN BECAUSE THE OPENED BREAKER DISCONNECTS THEIR FUEL SUPPLY. THEREFORE THE BUILDER/OWNER MUST BE SURE THAT THE INSTRUMENT PANEL, WIRING AND ENGINE ARE INSTALLED TO PREVENT CONTACT BETWEEN ELECTRICAL DEVICES AND SALT WATER.

# DC ELECTRICAL SYSTEM

## ENGINE WIRING DIAGRAM #36467

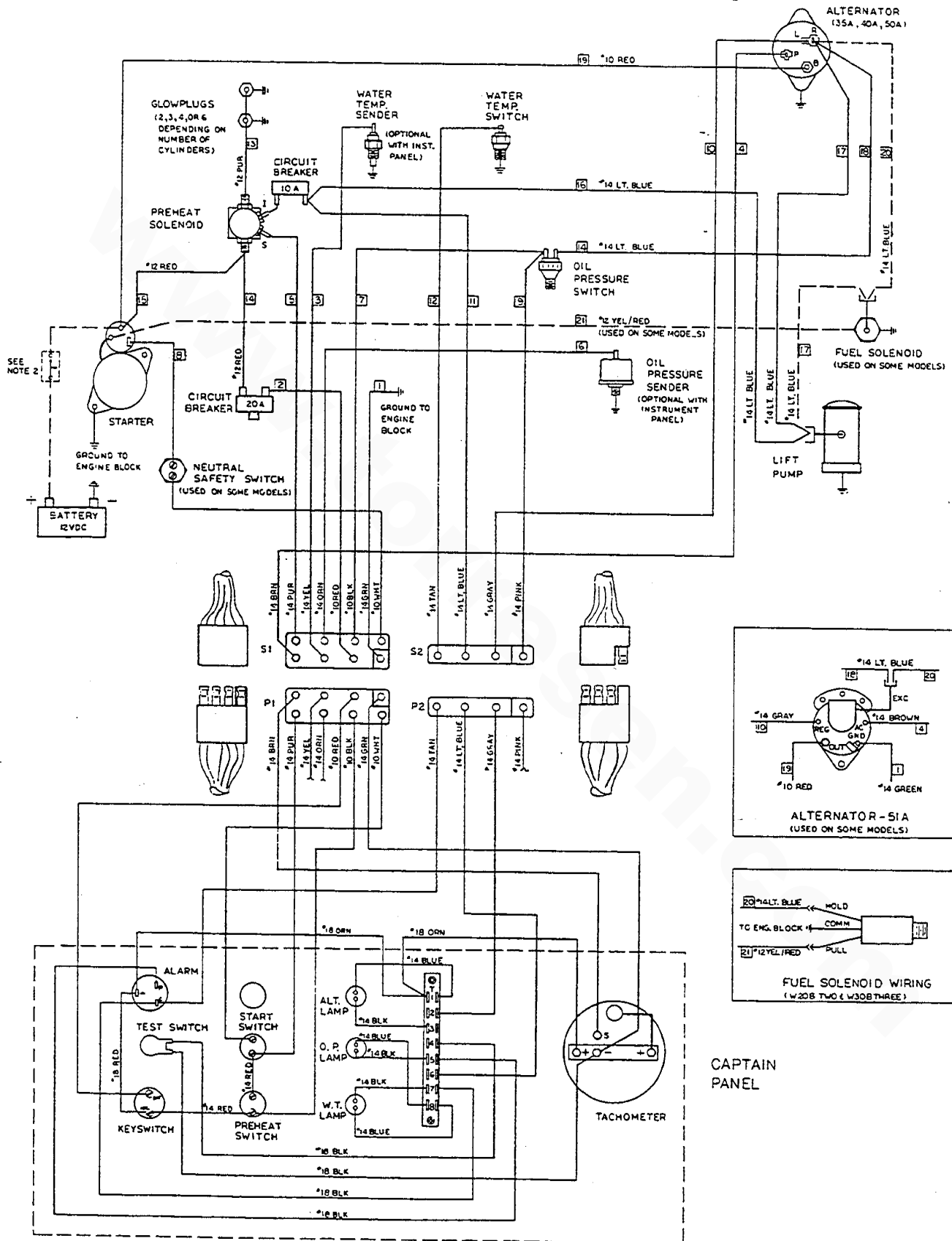

## DC ELECTRICAL SYSTEM

### ENGINE WIRING SCHEMATIC #36467

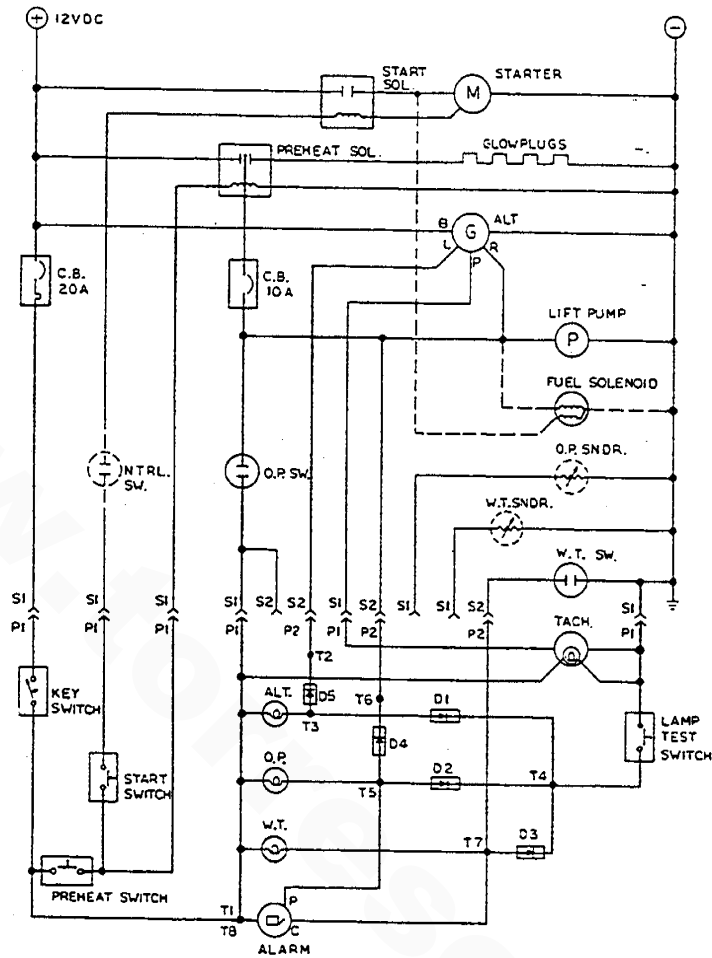

- START:**
1. TURN KEY TO ON POSITION. THE ALARM WILL SOUND, OIL PRESSURE AND BATTERY CHARGE INDICATORS WILL LIGHT.
  2. PUSH PREHEAT SWITCH FOR 15 TO 60 SECONDS AS REQUIRED, ALARM WILL STOP.
  3. WHILE CONTINUING TO PUSH PREHEAT SWITCH, PUSH THE START SWITCH. WHEN THE ENGINE STARTS RELEASE THE START SWITCH ONLY.
  4. WHEN THE OIL PRESSURE INDICATOR LAMP GOES OUT RELEASE THE PREHEAT SWITCH.

**STOP:** TURN THE KEY TO THE OFF POSITION.

**NOTES:**

1. THIS PRODUCT IS PROTECTED BY A MANUAL RESET CIRCUIT BREAKER LOCATED NEAR THE STARTER. EXCESSIVE CURRENT DRAIN WILL CAUSE THE BREAKER TO TRIP AND THE ENGINE WILL SHUT DOWN. THE BUILDER/OWNER MUST BE SURE THAT THE INSTRUMENT PANEL, WIRING AND ENGINE ARE INSTALLED TO PREVENT CONTACT BETWEEN ELECTRICAL DEVICES AND SALTWATER.
2. AN ON-OFF SWITCH SHOULD BE INSTALLED BETWEEN THE BATTERY AND STARTER TO DISCONNECT THE BATTERY IN AN EMERGENCY AND WHEN LEAVING THE BOAT. A SWITCH WITH A CONTINUOUS RATING OF 175 AMPS AT 12VDC WILL SERVE THIS FUNCTION. THIS SWITCH SHOULD NOT BE USED TO MAKE OR BREAK THE CIRCUIT.
3. PINK WIRE AT PLUG 2 IS UNUSED AND SHOULD BE INSULATED.



# DC ELECTRICAL SYSTEM

## ENGINE WIRING DIAGRAM #36844

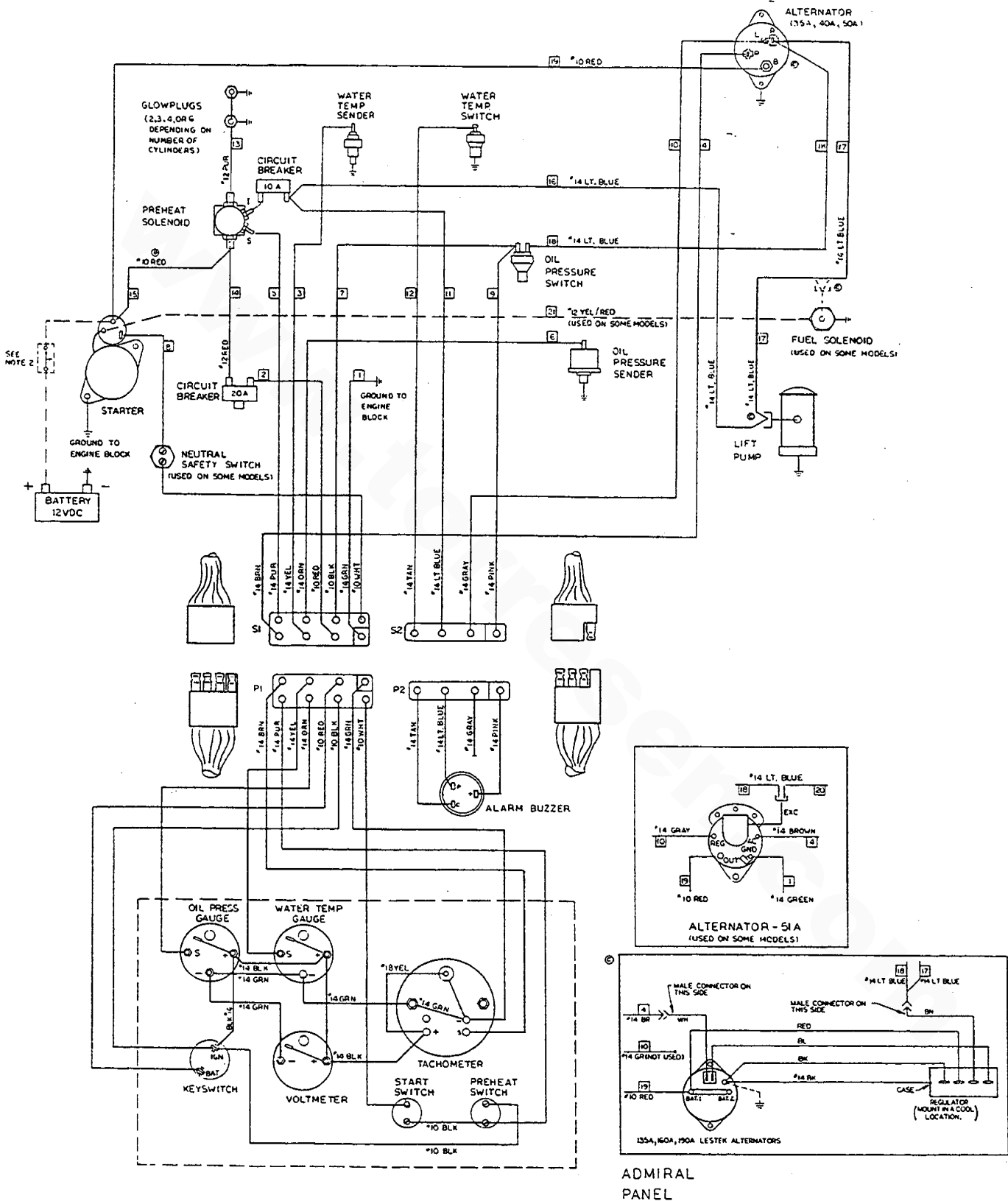

# DC ELECTRICAL SYSTEM

## ENGINE WIRING SCHEMATIC #36844

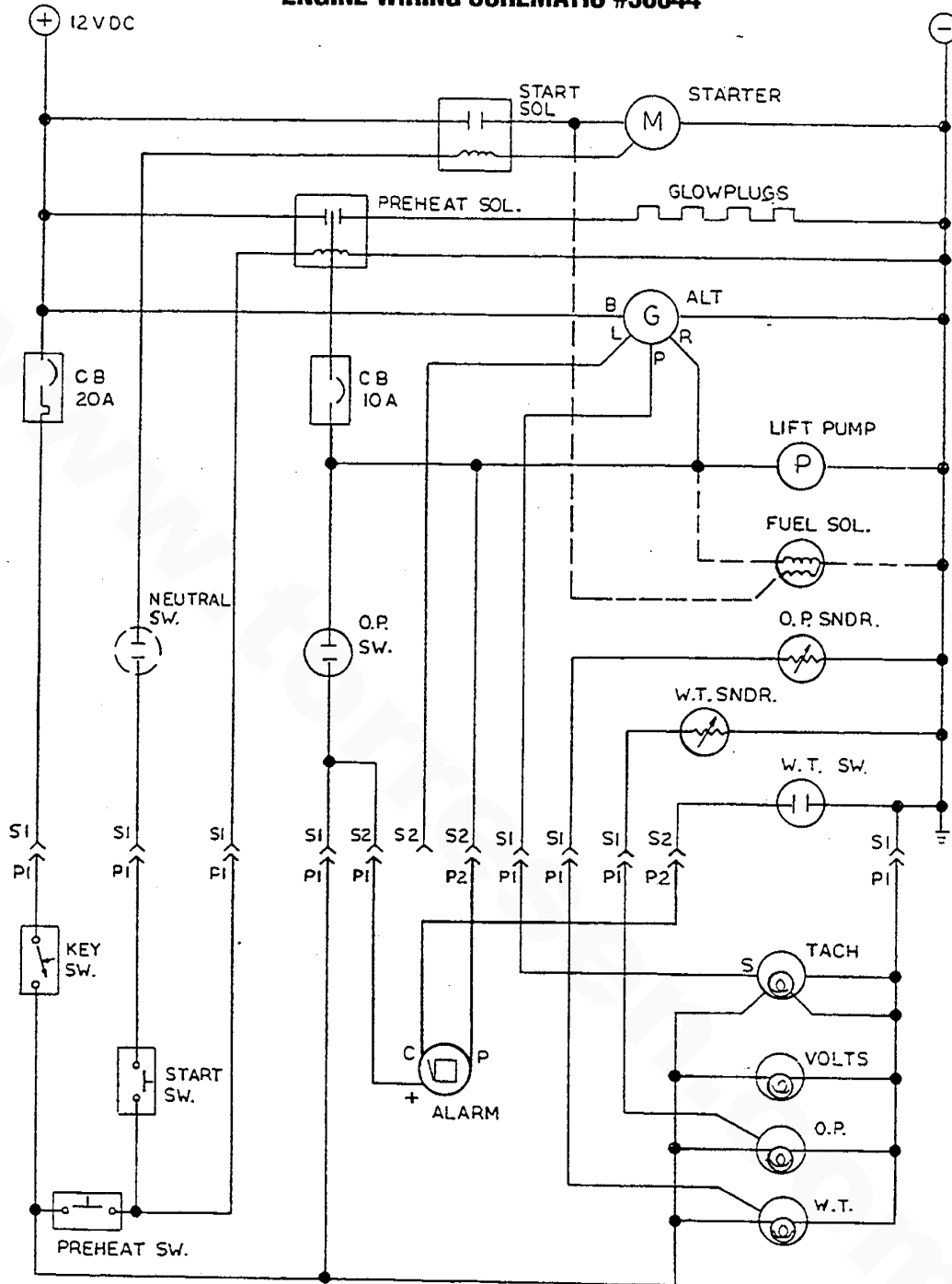

### NOTES:

1. THIS PRODUCT IS PROTECTED BY A MANUAL RESET CIRCUIT BREAKER LOCATED NEAR THE STARTER. EXCESSIVE CURRENT DRAIN WILL CAUSE THE BREAKER TO TRIP AND THE ENGINE WILL SHUT DOWN. THE BUILDER/OWNER MUST BE SURE THAT THE INSTRUMENT PANEL, WIRING AND ENGINE ARE INSTALLED TO PREVENT CONTACT BETWEEN ELECTRICAL DEVICES AND SALTWATER.
2. AN ON-OFF SWITCH SHOULD BE INSTALLED BETWEEN THE BATTERY AND STARTER TO DISCONNECT THE BATTERY IN AN EMERGENCY AND WHEN LEAVING THE BOAT. A SWITCH WITH A CONTINUOUS RATING OF 175 AMPS AT 12VDC WILL SERVE THIS FUNCTION. THIS SWITCH SHOULD NOT BE USED TO MAKE OR BREAK THE CIRCUIT.
3. GRAY WIRE AT PLUG 2 IS UNUSED AND SHOULD BE INSULATED.



# DC ELECTRICAL SYSTEM

## ENGINE WIRING DIAGRAM #39144

This diagram illustrates the 12 VDC negative ground electrical circuit. Two optional instrument panels are also shown: the Captains Panel and the Admirals Panel.

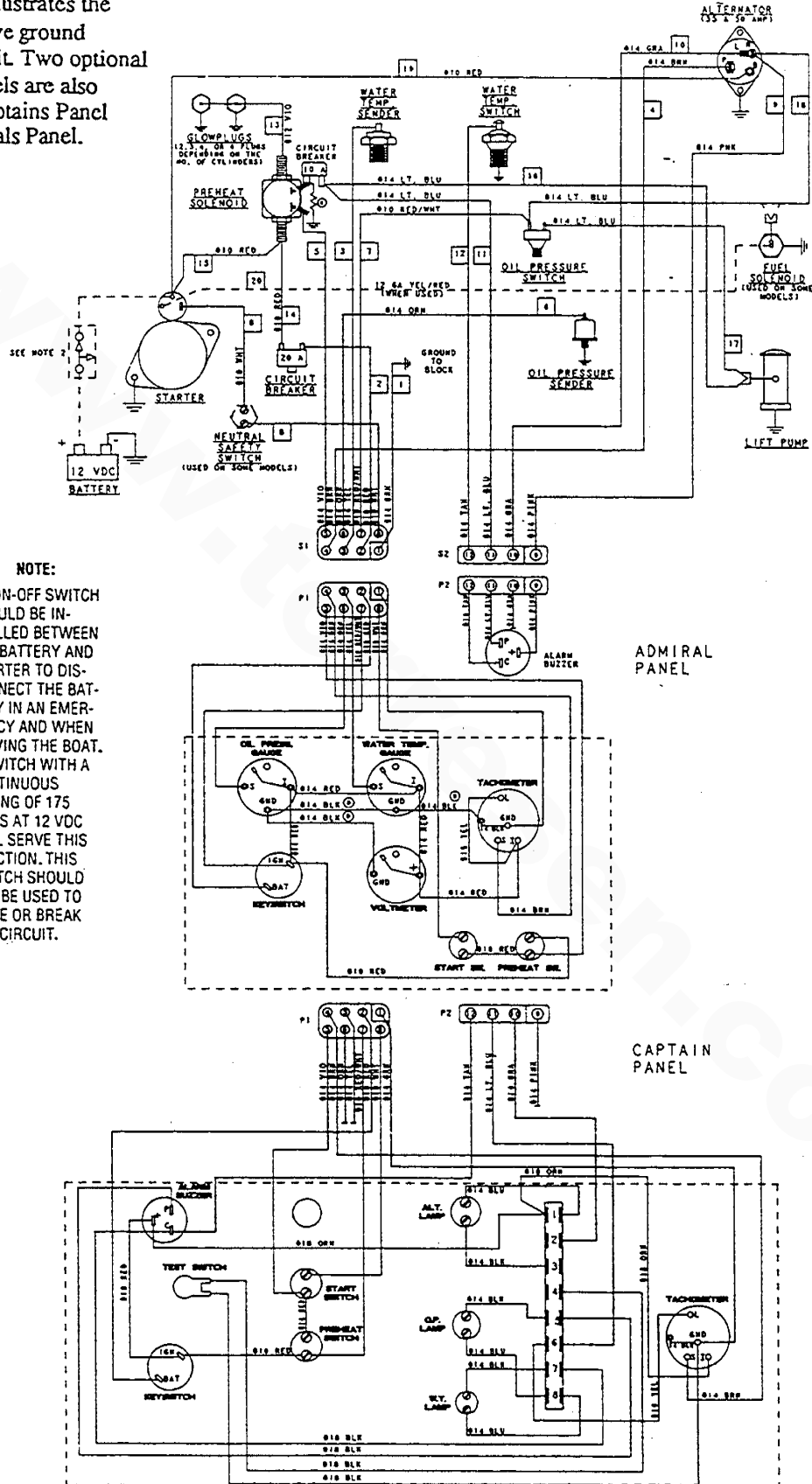

**NOTE:**

AN ON-OFF SWITCH SHOULD BE INSTALLED BETWEEN THE BATTERY AND STARTER TO DISCONNECT THE BATTERY IN AN EMERGENCY AND WHEN LEAVING THE BOAT. A SWITCH WITH A CONTINUOUS RATING OF 175 AMPS AT 12 VDC WILL SERVE THIS FUNCTION. THIS SWITCH SHOULD NOT BE USED TO MAKE OR BREAK THE CIRCUIT.





# DC ELECTRICAL SYSTEM

## ENGINE WIRING SCHEMATIC #39144

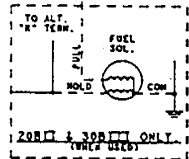
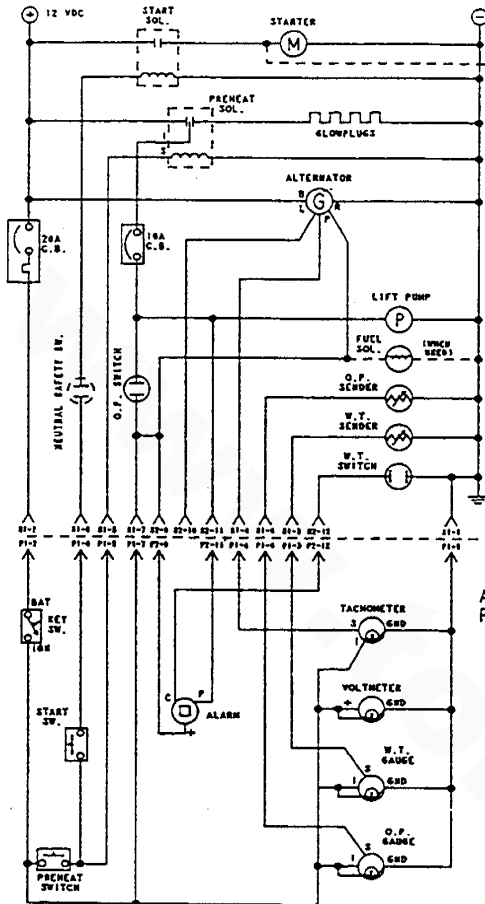

ADMIRAL PANEL

**NOTES:**

1. THIS PRODUCT IS PROTECTED BY A MANUAL RESET CIRCUIT BREAKER LOCATED NEAR THE STARTER. EXCESSIVE CURRENT WILL CAUSE THE BREAKER TO TRIP AND THE ENGINE WILL SHUT DOWN. THE BUILDER/OWNER MUST BE SURE THAT THE INSTRUMENT PANEL, WIRING, AND ENGINE ARE INSTALLED TO PREVENT CONTACT BETWEEN ELECTRICAL DEVICES AND SEAWATER.
2. AN ON-OFF SWITCH SHOULD BE INSTALLED BETWEEN THE BATTERY AND STARTER TO DISCONNECT THE BATTERY IN AN EMERGENCY AND WHEN LEAVING THE BOAT. A SWITCH WITH A CONTINUOUS RATING OF 175 AMPS AT 12 VDC WILL SERVE THIS FUNCTION. THIS SWITCH SHOULD NOT BE USED TO MAKE OR BREAK THE CIRCUIT.
3. THE PINK WIRE AT PLUG 2 IS UNUSED AND SHOULD BE INSULATED, CAPTAIN PANEL ONLY.
4. THE GRAY WIRE AT PLUG 2 IS UNUSED AND SHOULD BE INSULATED, ADMIRAL PANEL ONLY.

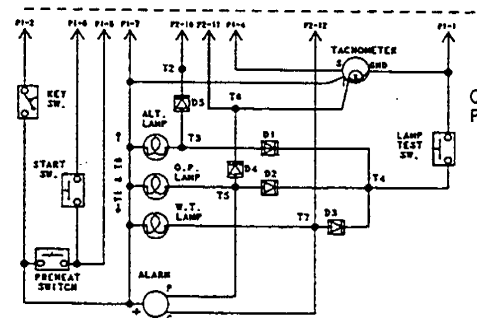

CAPTAIN PANEL

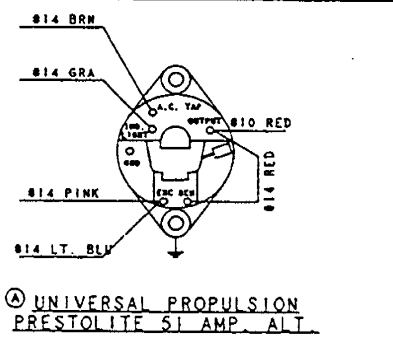
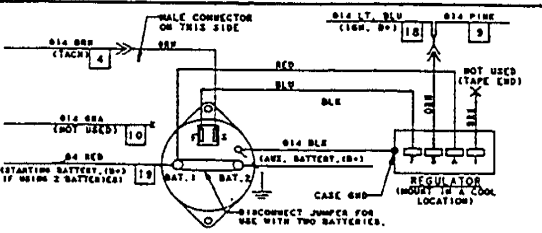
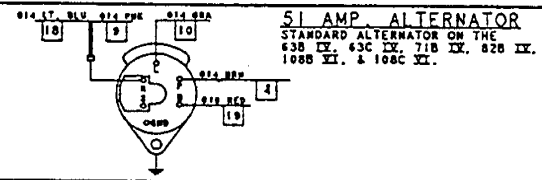
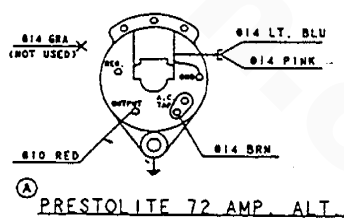

## STANDARD HARDWARE TORQUES

**NOTE:** Unless stated otherwise for a specific assembly, use the following torque values when tightening standard hardware.

Grade 4	Pitch	lb-ft	kg-m
6mm bolt head/nut	1	2.9-5.1	0.4-0.7
8mm bolt head/nut	1.25	7.2-11.6	1.0-1.6
10mm bolt head/nut	1.25	13.7-22.4	1.9-3.1
10mm bolt head/nut	1.5	13.0-21.7	1.8-3.0
12mm bolt head/nut	1.25 (ISO)	25.3-39.8	3.5-5.5
12mm bolt head/nut	1.5	25.3-39.8	3.5-5.5
12mm bolt head/nut	1.75	21.7-36.2	3.0-5.0
13mm bolt head/nut	1.5	32.5-50.6	4.5-7.0
14mm bolt head/nut	1.5	36.2-57.9	5.0-8.0
14mm bolt head/nut	2	34.0-55.7	4.7-7.7
16mm bolt head/nut	1.5	54.2-79.6	7.5-11.0
16mm bolt head/nut	2	51.4-76.7	7.1-10.6
<b>Grade 6T</b>			
6mm bolt head/nut	1	4.3-6.5	0.6-0.9
8mm bolt head/nut	1.25	10.8-15.9	1.5-2.2
10mm bolt head/nut	1.25	21.7-32.5	3.0-4.5
10mm bolt head/nut	1.5	19.5-30.4	2.7-4.2
12mm bolt head/nut	1.25 (ISO)	36.2-57.9	5.0-8.0
12mm bolt head/nut	1.5	36.2-50.6	5.0-7.0
12mm bolt head/nut	1.75	34.7-49.2	4.8-6.8

Grade 7T, 8T and 8.8	Pitch	lb-ft	kg-m
6mm bolt head/nut	1	5.8-8.7	0.8-1.2
8mm bolt head/nut	1.25	14.5-21.7	2.0-3.0
10mm bolt head/nut	1.25	28.9-39.8	4.0-5.5
10mm bolt head/nut	1.5	26.8-37.6	3.7-5.2
12mm bolt head/nut	1.25 (ISO)	54.2-75.9	7.5-10.5
12mm bolt head/nut	1.5	50.6-65.1	7.0-9.0
12mm bolt head/nut	1.75	43.4-61.5	6.0-8.5
13mm bolt head/nut	1.5	57.9-86.8	8.0-12.0
14mm bolt head/nut	1.5	72.3-108.5	10.0-15.0
14mm bolt head/nut	2	68.7-101.3	9.5-14.0
16mm bolt head/nut	1.5	108.5-166.4	15.0-23.0
16mm bolt head/nut	2	101.3-159.1	14.0-22.0
<b>Grade 5 Cap Screw</b>			
1/4 UNC		9-11	1.2-1.5
1/4 UNF		11-13	1.5-1.8
5/16 UNC		18-20	2.5-2.8
5/16 UNF		21-23	2.9-3.2
3/8 UNC		28-33	3.7-4.6
3/8 UNF		30-35	4.1-4.8
7/16 UNC		44-49	6.1-6.8
7/16 UNF		50-55	6.9-7.6
1/2 UNC		68-73	9.4-10.1
1/2 UNF		73-80	10.1-11.1



## METRIC CONVERSIONS

INCHES TO MILLIMETERS				MILLIMETERS TO INCHES			
Inches	mm	Inches	mm	mm	Inches	mm	Inches
1	25.40	15	381.00	1	0.0394	15	0.5906
2	50.80	20	508.00	2	0.0787	20	0.7874
3	76.20	25	635.00	3	0.1181	25	0.9843
4	101.60	30	762.00	4	0.1575	30	1.1811
5	127.00	35	889.00	5	0.1969	35	1.3780
10	254.00	40	1016.00	10	0.3937	40	1.5748

10 MILLIMETERS = 1 CENTIMETER, 100 CENTIMETERS = 1 METER = 39.37 INCHES (3.3 FEET)

INCHES TO METERS				METERS TO INCHES			
Inches	Meters	Inches	Meters	Meters	Inches	Meters	Inches
1	0.0254	7	0.1778	0.1	3.937	0.7	27.559
2	0.0508	8	0.2032	0.2	7.874	0.8	31.496
3	0.0762	9	0.2286	0.3	11.811	0.9	35.433
4	0.1016	10	0.2540	0.4	15.748	1.0	39.370
5	0.1270	11	0.2794	0.5	19.685	1.1	43.307
6	0.1524	12	0.3048	0.6	23.622	1.2	47.244

TO CONVERT METERS TO CENTIMETERS, MOVE DECIMAL POINT TWO PLACES TO THE RIGHT

YARDS TO METERS				METERS TO YARDS			
Yards	Meters	Yards	Meters	Meters	Yards	Meters	Yards
1	0.91440	6	5.48640	1	1.09361	6	6.56168
2	1.82880	7	6.40080	2	2.18723	7	7.65529
3	2.74320	8	7.31520	3	3.28084	8	8.74891
4	3.65760	9	8.22960	4	4.37445	9	9.84252
5	4.57200	10	9.14400	5	5.46807	10	10.93614

MOVE DECIMAL POINT FOR HIGHER VALUES — e.g. 6,000 METERS = 6,561.68 YARDS

POUNDS TO KILOGRAMS				KILOGRAMS TO POUNDS			
lb	kg	lb	kg	kg	lb	kg	lb
1	0.454	6	2.722	1	2.205	6	13.228
2	0.907	7	3.175	2	4.409	7	15.432
3	1.361	8	3.629	3	6.614	8	17.637
4	1.814	9	4.082	4	8.818	9	19.842
5	2.268	10	4.536	5	11.023	10	22.046

GALLONS TO LITERS				LITERS TO GALLONS			
Gallons	Liters	Gallons	Liters	Liters	Gallons	Liters	Gallons
1	3.79	10	37.86	1	0.26	60	15.66
2	7.57	20	75.71	2	0.53	90	23.77
3	11.36	30	113.57	5	1.32	120	31.32
4	15.14	40	151.42	10	2.64	150	39.62
5	18.93	50	189.28	20	5.28	180	47.54

PINTS TO LITERS				LITERS TO PINTS			
Pints	Liters	Pints	Liters	Liters	Pints	Liters	Pints
1	0.47	6	2.84	1	2.11	6	12.68
2	0.95	7	3.31	2	4.23	7	14.79
3	1.42	8	3.79	3	6.34	8	16.91
4	1.89	9	4.26	4	8.45	9	19.02
5	2.37	10	4.73	5	10.57	10	21.13

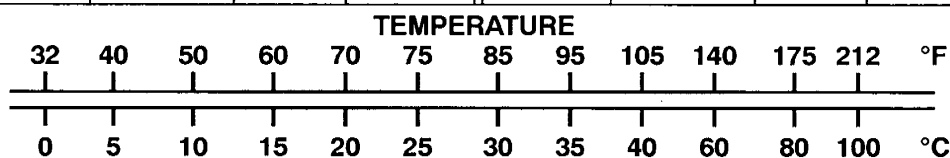

## GENERATOR INFORMATION

### USE OF ELECTRIC MOTORS

The power required to start an electric motor is considerably more than is required to keep it running after it is started. Some motors require much more current to start them than others. Split-phase (AC) motors require more current to start, under similar circumstances, than other types. They are commonly used on easy-starting loads, such as washing machines, or where loads are applied after the motor is started, such as small power tools. Because they require 5 to 7 times as much current to start as to run, their use should be avoided, whenever possible, if the electric motor is to be driven by a small generator. Capacitor and repulsion-induction motors require from 2 to 4 times as much current to start as to run. The current required to start any motor varies with the load connected to it. An electric motor connected to an air compressor, for example, will require more current than a motor to which no load is connected.

In general, the current required to start 115-volt motors connected to medium starting loads will be approximately as follows:

MOTOR SIZE (HP)	AMPS FOR RUNNING (AMPERES)	AMPS FOR STARTING (AMPERES)
1/6	3.2	6.4 – 22.4*
1/4	4.6	9.2 – 32.2*
1/3	5.2	10.4 – 72.8*
1/2	7.2	14.4 – 29.2
3/4	10.2	20.4 – 40.8
1	13.0	26 – 52

**\*NOTE:** In the above table the maximum "Amps for Starting" is more for some small motors than for larger ones. The reason for this is that the hardest starting types (split-phase) are not made in larger sizes.

Because the heavy surge of current needed for starting motors is required for only an instant, the generator will not be damaged if it can bring the motor up to speed in a few seconds. If difficulty is experienced in starting motors, turn off all other electrical loads and, if possible, reduce the load on the electric motor.

### REQUIRED OPERATING SPEED

Although individual units may vary slightly, the normal voltage and frequency of typical 60 (50) hertz engine-driven generators described in this manual are approximately as follows: run first with no-load applied, then at half the generator's capacity, and finally loaded to its full capacity as indicated on the generator's data plate.

The output voltage should be checked periodically to ensure proper operation of the generating plant and the appliances it supplies.

### GENERATOR FREQUENCY ADJUSTMENT

Frequency is a direct result of engine/generator speed, as indicated by the following:

- When the generator is run at 1800 rpm, the AC voltage output frequency is 60 hertz.
- When the generator is run at 1500 rpm, the AC voltage output frequency is 50 hertz.

Therefore, to change the generator's frequency, the generator's drive engine's speed must be changed.

### GENERATOR MAINTENANCE

- Maintaining reasonable cleanliness is important. Connections of terminal boards and rectifiers may become corroded, and insulation surfaces may start conducting if salts, dust, engine exhaust, carbon, etc. are allowed to build up. Clogged ventilation openings may cause excessive heating and reduced life of windings.
- For unusually severe conditions, thin rust-inhibiting petroleum-base coatings should be sprayed or brushed over all surfaces to reduce rusting and corrosion. Typical materials suggested are *Ashland Tectyle 506* and *Daubert Chemical Co. Non-Rust AC-410*.
- In addition to periodic cleaning, the generator should be inspected for (a) tightness of all connections, (b) evidence of overheated terminals, and (c) loose or damaged wires.
- The drive discs on single bearing generators should be checked periodically if possible for tightness of screws and for any evidence of incipient cracking failure. Discs should not be allowed to become rusty because rust may accelerate cracking. The bolts which fasten the drive disc to the generator shaft must be hardened steel SAE grade 8, identified by 6 radial marks, one at each of the 6 corners of the head.
- The rear armature bearing is lubricated and sealed; no maintenance is required. However, if the bearing becomes noisy or rough-sounding, have it replaced.
- Examine the bearing at periodic intervals. No side movement of the shaft should be detected when force is applied. If side motion is detectable, the bearings are wearing or wear on the shaft of the bearing socket outside bearing has occurred. Repair must be made quickly or major components will rub and cause major damage to the generator.
- Examine the control box at periodic intervals to detect cracks from engine and generator vibration. If cracks in the box are seen, engine vibration may be severe, requiring bracing in the box for additional strength to resist vibration.

### GENERATOR TROUBLESHOOTING

A complete and illustrated text on troubleshooting and servicing the WMD and BT generators is furnished in the following pages.



## WMD GENERATOR

### DESCRIPTION

The WMD model generator is a self-exciting and self-regulating brush style generator, requiring only a driving force to produce voltage. It is four lead reconnectable for 115 volts or 115/230 volts, and has a four pole revolving armature with no DC brushes or commutator. It has a solid state bridge rectifier in the exciter circuit, AC slip rings, a drip-proof construction, and a single bearing design. Voltage regulation is 7% no-load to full-load, and frequency regulation is 3-4 hertz no-load to full-load. It is in insulation class "F" as defined by MEMA MGI-1.65, and its temperature rise is within MEMA MGI-22.40 definition when operating at full-load. Its centrifugal-type blower fan is direct connected to the armature shaft for cooling. Capacitors across the hot leg and neutral minimize radio interference within the limits of most commercial and civilian applications. The armature is balanced laminated steel, double dipped and baked. The field ring is thick hot rolled steel with a welded bearing support bracket, machined as an assembly for precise bearing alignment. The rear carrier bearing is pre-lubricated, double sealed with an anti-rotation lock.

WMD GENERATOR SPECIFICATIONS

FREQUENCY	60 HERTZ STANDARD	
<b>RPM</b>	1800 for 60 Hertz 1500 for 50 Hertz	
NOTE: To convert a 60 Hz unit to 50 Hz, the armature must be changed.		
<b>Voltage Normal</b>	115 VAC	230 VAC
Maximum	132 VAC	264 VAC
Minimum	108 VAC	216 VAC
<b>Excitation Voltage</b>	115 VAC (output voltage supplied to rectifier)	
<b>Field Excitation Voltage</b>	190 VDC (approximate)	

### DISASSEMBLY

1. Lift and support the back end of the engine so that the generator is not resting on its isolators.
2. Remove the generator endbell cover. This exposes the fan and brush rig assembly. Remove the fan assembly with its hardware.
3. Remove the brush rig assembly. This can be done in two half assemblies. Unbolt the two half-moon assemblies from the frame attachment and lift the two halves away from the slip rings. Mark the polarity of the two leads on the bridge rectifier that go to the field coils and unplug these from the bridge rectifier. The two half-moon brush assemblies can be removed from the generator by removing the heavy output leads G1, G2, G3 and G4 from their attachment point on each brush holder. Make a rough sketch as to where each of these leads attaches on each assembly half. There are 8 leads that are paired in the control panel to provide four reconnectable leads. Inspect and replace components in the brush rig as needed. Do not totally disassemble as this is not needed.
4. Remove the control panel from the top of the generator housing. Mark all leads as needed for proper assembly.
5. Unbolt the generator housing from the bellhousing. A puller may be needed at the bearing end to assist in pulling the housing with or without the bearing off the armature. Some gentle prying at the bellhousing end will be needed

as well. The housing with field coils is heavy. Once the housing has cleared the armature shaft, it should be supported and slowly drawn over the armature. Try not to drag it over the armature.

### INSPECTION

1. Inspect the bearing and replace as needed. If the unit is going through a major overhaul, bearing replacement is recommended.
2. Check the field coils resistance values. Remove the field coils from the housing. Note and mark each field coil's position in the housing. Do not mix them up! Each coil has a different part number and a specific position in the housing. Incorrect assembly will cause low voltage output.
3. Unbolt the armature from the flywheel. Test the armature with an ohmmeter. Clean the slip rings and polish using a crocus cloth.

### REASSEMBLY

Reassemble in reverse order.

**NOTE:** When assembling the housing onto the generator armature, be sure to properly align the anti-slip groove in the bearing with the hole in the housing and install a new lock pin.

The fan on the back end plays an important part in moving air through the generator for cooling. In installations where surrounding air is limited, outside air should be ducted to the area of the screened endbell inlet to provide this needed air for cooling, and combustion as well.

The security of the generator fan hold down nut should be checked at installation (commissioning), at the initial 50-hour servicing of the generator unit, and periodically thereafter (200-300 hours). The cooling fan securing nut should be tight enough so that when force is applied to rotate the fan by pushing on the outer edge and blades with the palm of your hand (protect the hand with a cloth or a glove), you should be able to turn the generator and engine without the fan slipping on the shaft. If properly torqued and the fan still slips, replace the lockwashers.

Recirculation of generator cooling air through the generator must be avoided. The generator compartment ventilation must be sufficient to prevent generator air recirculation. Insure that the screened endbell inlet and the screened discharge slots at the flywheel are not obstructed, preventing good air circulation through the generator while it is running.

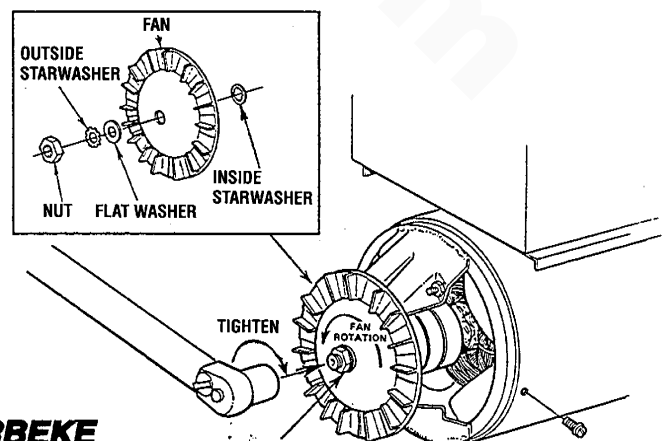

## WMD GENERATOR TROUBLESHOOTING

### NO ELECTRICAL OUTPUT

1. Remove the load from the generator and verify no output directly at the generator output leads with a voltmeter.
2. Check for proper electrical connections. Refer to the *INTERNAL WIRING DIAGRAMS*.

**NOTE:** The generator armature slip rings and brush rigs are numbered from inboard at the windings or flywheel end outward toward the rear support bearing.

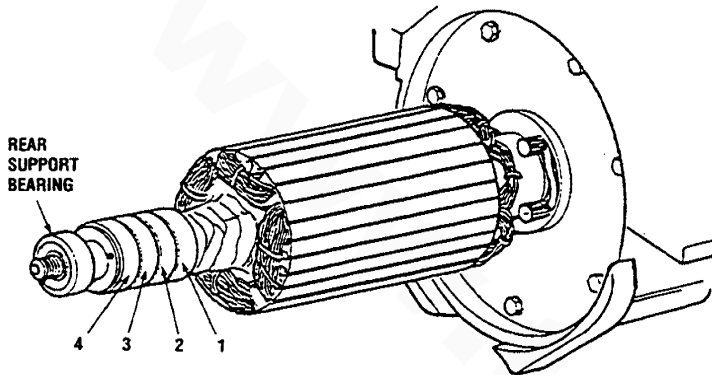

3. For a residual voltage check, disconnect the field leads from the bridge rectifier. Note the position of the leads on the rectifier (+) to (+) and (-) to (-). Operate the generator and check the AC output (no load on generator). Measure the voltage between the neutral lead and the hot lead(s) (3 and 4 wire unit — 2.5 volts AC each hot lead to neutral approximate).

If the residual voltage checks OK: you can assume the rotating armature and brush rig are OK. The generator's problem lies in the rectifier and/or the field coils.

If residual voltage is not present: Check the brush rig and the static capacitors. Check the rotating armature resistance values and the continuity check found under *Flash Field Coils*.

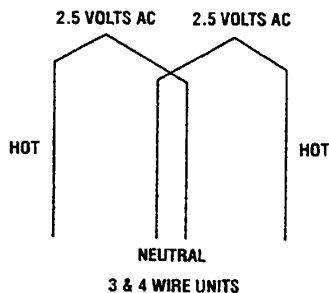

4. Test the operation of the generator by bypassing the bridge rectifier. Apply 12 volts DC to the field leads on the bridge rectifier (+) to (+) and (-) to (-). Run the generator (no-load). Measure the voltage output at the generator leads. Generator output with 12 volts DC excitation to the field coils should be 50 to 70 volts AC. If 50 to 70 volts AC is produced, this should indicate that the generator is OK, and that the bridge rectifier is defective.

5. If no voltage is produced, check the static capacitor(s) that it is not shorted to ground. If one is found faulty, remove the connection from the output terminal at the brush rig and repeat Step #3.

### FLASH FIELD COILS

1. Units may lose their residual magnetism from extended storage, or rough handling during installation or disassembly and assembly for installation, etc., requiring the field coils to be excited with 6 to 12 volts DC to restore the magnetism to the generator. This is done in the following manner:

Stop the engine and remove the generator endbell cover. This will expose the cooling fan, brush rig assembly and rectifier. Check internal wiring (see diagram). The positive (+) lead from the field coils is connected to the positive marked terminal on the rectifier and the negative (-) lead from the field coils is connected to the opposite *unmarked* terminal on the rectifier. Using jumper leads with insulated alligator clips, connect 6 to 12 volts DC battery positive to the positive of the rectifier and negative to the *unmarked* terminal of the rectifier for approximately 10 seconds. This should restore magnetism to the stationary field coils.

**CAUTION:** Be careful not to connect DC voltage to the AC terminals on the rectifier, as this will damage the rectifier.

Remove the alligator clip connections; replace the endbell cover and operate the generator and check AC output voltage.

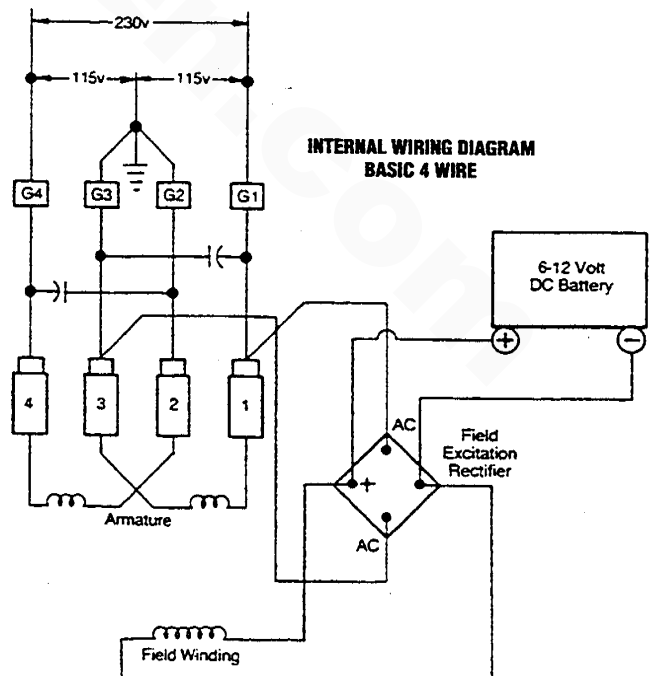

2. Check for a short or open in the rotating armature or in the stationary field coils.

ROTATING ARMATURE (RESISTANCE VALUES)	
WMD 11.0 and 12.5 KW	1 ohm or less between slip rings (1&3) and (2&4)

**NOTE:** 4-wire units: there should be no continuity found between slip rings (1&2), (2&3) and (3&4). If continuity is found, an internal short exists between these windings and the armature should be replaced.

**NOTE:** There should be no continuity found between any of the slip rings and the armature's central steel shaft. If continuity is found, the windings are shorted to the shaft and the armature should be replaced.

Rotating armature slip rings are numbered from inboard of the generator flywheel end outward to the rear support bearing. When referring to 2, 3 and 4-wire units, these are the number of generator output leads being connected to the load. You will find on the 11.0 and 12.5 KW units that there are 8 leads coming from the brush rig and they are in pairs that are combined for a total of 4 output leads. The number of wires can also be related to the number of slip rings on the rotating armature.

### REPLACEMENT OF FIELD COIL(S)

1. Field coils are connected in series and the resistance value given in this text is the total of the four field coils. To determine the resistance value of one, divide by four. Each field coil has a mounting position on the generator housing and cannot be interchanged with another field coil.

When installing a replacement field coil(s), the installer must ensure that the coil is correct for the mounting position in the housing and will have the correct polarity when excited with 9–12 volts DC.

The field coil shoes that hold the coil securely to the generator housing are held in place by bolts that must be properly tightened when the coil and shoe are installed to the generator housing. When connecting the coils in series ensure the butt connections are good and secure and positioned away from rotating parts.

To ensure the field coils have been positioned properly in the generator housing and will have the correct polarity, the following test *must* be made before reassembly of the generator.

- a. Connect a 9–12 volt DC battery to the leads off the coils that would normally be connected to the (+) and (–) connectors of the bridge rectifier. These leads are unmarked and the polarity in their connection to the DC battery is not important.

**NOTE:** When removing the leads from the battery and reconnecting them to the bridge rectifier, you should maintain the same polarity as used in this test: plus lead to (+) on rectifier and negative to unmarked (–) connection to rectifier.

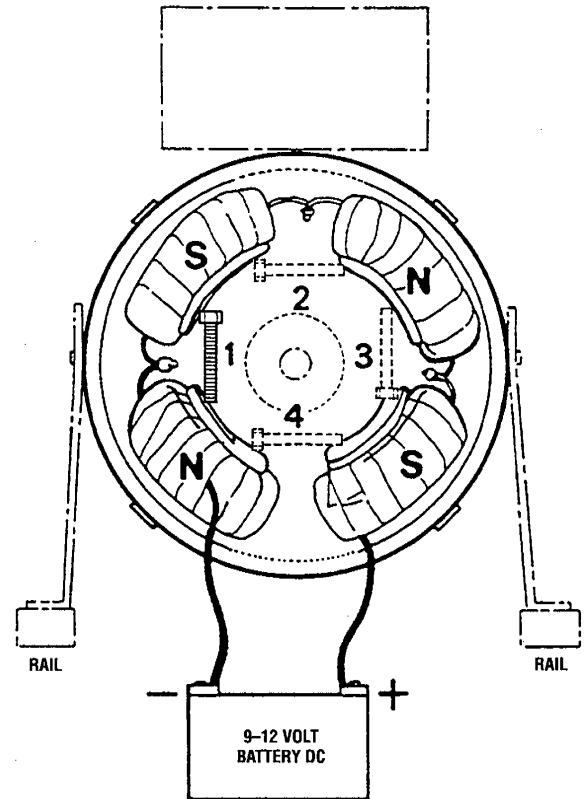

**TESTING THE FIELD COILS**

- b. Using a 3-inch iron bolt or its equivalent, place this bolt between each adjoining field coil/shoes. It should be held in place by the magnetic attraction set up between the coil/shoes by the 9–12 volts excitation of the field coils. Should this fail to happen between any of the four adjoining coils/shoes, then an incorrect coil is installed and must be removed and the correct one installed; otherwise the generator, when assembled, will not produce proper voltage.

### LOW VOLTAGE OUTPUT

1. Verify the voltage output at the generator output leads with load applied to the generator; check the no-load condition also. Check the voltage at the load. Check the rating for the generator and verify the load with an amp probe at the output leads. Check all connections to ensure they are clean and secure. Ensure that the wire size carrying the voltage to the load is of sufficient size so as not to produce a voltage drop.

**NOTE:** Beware of motor starting loads and the amperage draw placed on the generator from these types of loads. Generally, the amperage draw of a motor at start-up will be 3–5 times the amperage needed when running.

Ensure that the engine no-load speed is producing 125–132 (250–264) volts from the generator. Lower no-load voltage can result in low output voltage at rated amperage output.

- Check the generator with a Hertz meter:

**No-Load Hertz** 61–61.5 (51–51.5)  
**No-Load Voltage** 130–132 volts (generator cold)  
**No-Load Voltage** 126–130 volts (generator hot)

- Test the Bridge Rectifier. The bridge rectifier may be faulty and should be checked as follows:

The field excitation rectifier is a full-wave bridge rectifier. This type of rectifier has four terminals: two AC, a DC positive, and a DC negative. The rectifier is tested in the following manner: Connect one ohmmeter lead to the positive DC terminal, and the other lead to each of the AC terminals in turn. A high or low resistance reading will be obtained. Reverse the meter leads, and an opposite reading should be observed. Now check from the negative terminal to each of the AC terminals, using the same procedures as above. Check each terminal to the case, and no resistance reading should be observed.

If a battery-powered test light is used, follow the procedures described above. If the rectifier is good, the light will come on, in one direction only.

If the rectifier fails any of the above tests, it should be considered defective and replaced.

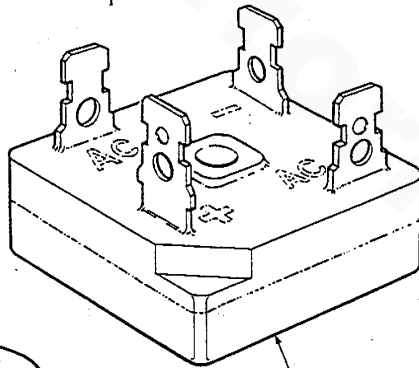

**TESTING THE BRIDGE RECTIFIER**

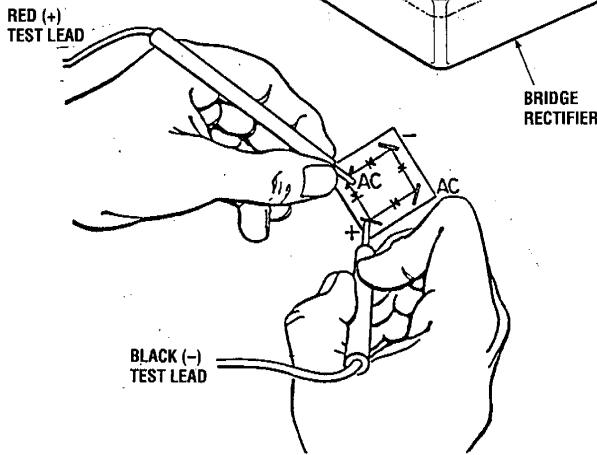

- Check the field coil resistance as per the following specifications:

FIELD COIL RESISTANCE (TOTAL)		
WMD 11.0 KW and 12.5 KW	Aluminum Windings 14.2 ohms (3.5 ohms per coil)	±5%
	Copper Windings 22.6 ohms (5.65 ohms per coil)	±5%

- Insufficient cooling of the generator. Ambient air entering the generator should not exceed 104°F (40°C). Operating efficiency of the generator decreases as the ambient air temperature entering the generator endbell increases above 104°F. Generators in confined areas may require the ducting of cool outside air into the compartment, directed toward the inlet at the generator endbell.
- Check the condition of the brushes for wear and contact with the slip rings on the armature. Ensure that the brushes are not sticking in the holders.
- Condenser Testing. Condensers are built into the generator circuit to minimize radio interference during operation. If a condenser shorts out, it shorts the generator output. To determine whether a condenser is shorted, stop the generator, disconnect the lead wire from the brush holder to which the condenser is connected, start the generator and check the output. If the generator then provides power, the condenser was at fault and should be replaced. (If the generator did not provide power after the lead wire was disconnected, the problem was not caused by that condenser.) Reconnect the lead wire.

**NOTE:** There should be no continuity found between the lead end from the condenser and the metal case of the condenser. If so, the condenser is shorted.

### HIGH VOLTAGE OUTPUT

- Verify the voltage at the generator output leads.

**No-Load Voltage** 126–130 volts (generator hot)  
 61.5–62.0 hertz

- Check the internal wiring of the generator leads attached to the brush rig and the leads from the brush rig feeding AC to the bridge rectifier. One connection is from a hot brush rig and the other must be from a neutral brush rig.

### SOLENOID WITH THROTTLE LINKAGE

The solenoid plunger *must* move smoothly and rapidly into the solenoid when the solenoid is electrically energized, drawing with it the engine throttle arm into the set speed run position. Failure of the solenoid plunger to bottom in the solenoid will result in a failed solenoid.

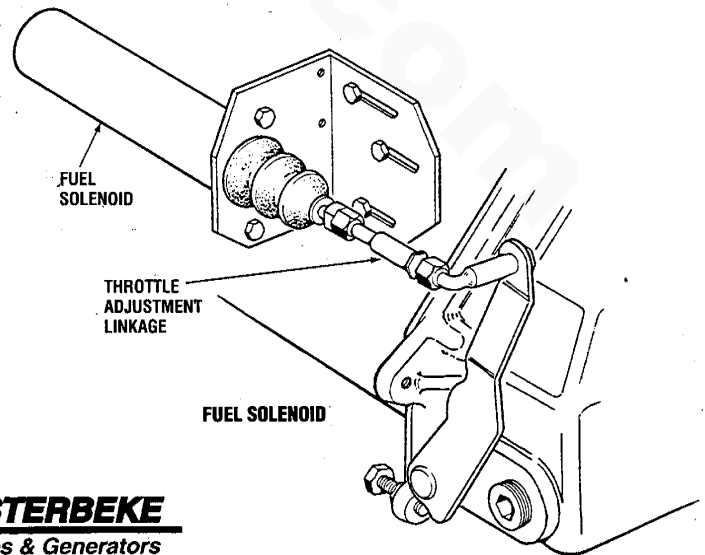



**60 HERTZ — 4 WIRE RECONNECTABLE**

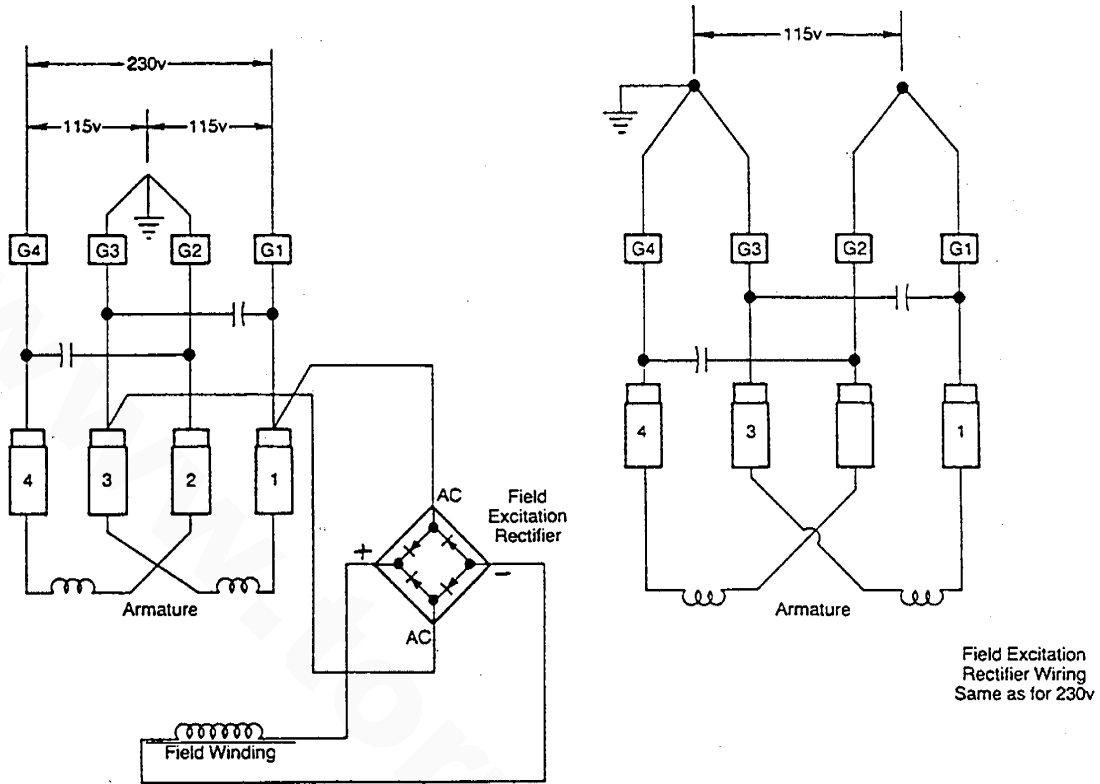

**50 HERTZ — 2 WIRE RECONNECTABLE**

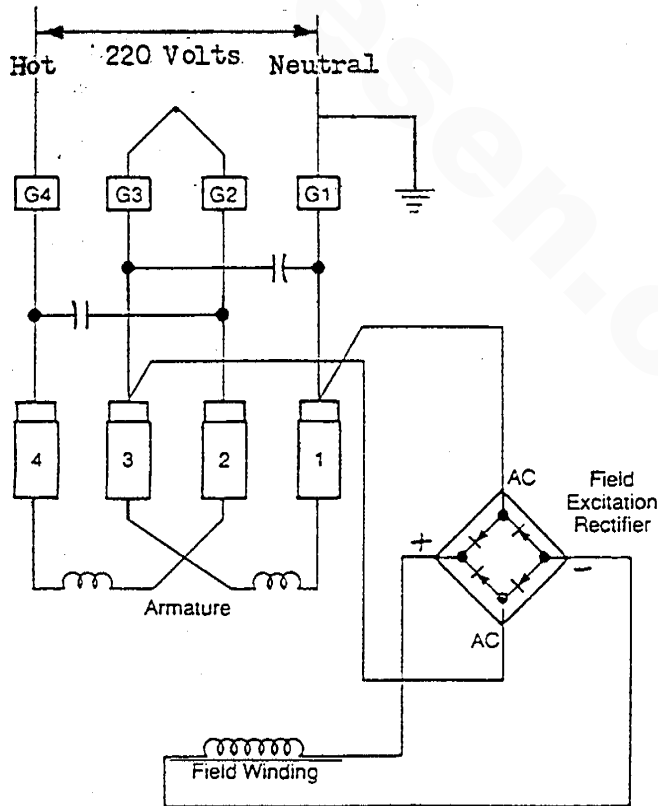

**DESCRIPTION**

This generator is a brushless self-excited generator, which requires only the driving force of the engine to produce AC output. The copper and laminated iron in the exciter stator are responsible for the self-exciting feature of this generator. The magnetic field creates an electromagnetic field which rotates through the windings of the main stator, inducing AC voltage which is supplied to a load. A transformer is connected in parallel to the AC output of the main stator. An AC voltage is produced in the auxiliary windings of the transformer and main stator and is, in turn, supplied to a full-wave bridge rectifier. The rectifier produces a DC voltage to further excite the exciter stator windings, enabling the generator to produce a rated AC output as the generator speed reaches its set hertz rpm.

An optional solid-state voltage regulator is available to work in tandem with the transformer regulator to produce a more stable AC output.

A circuit breaker is installed on all current WESTERBEKE generators. This circuit breaker will automatically disconnect generator power in case of an electrical overload. The circuit breaker can be manually shut off when servicing the generator to insure that no power is coming into the generator.

**NOTE:** This circuit breaker is available as a WESTERBEKE add-on kit for earlier model generators; contact your WESTERBEKE DEALER.

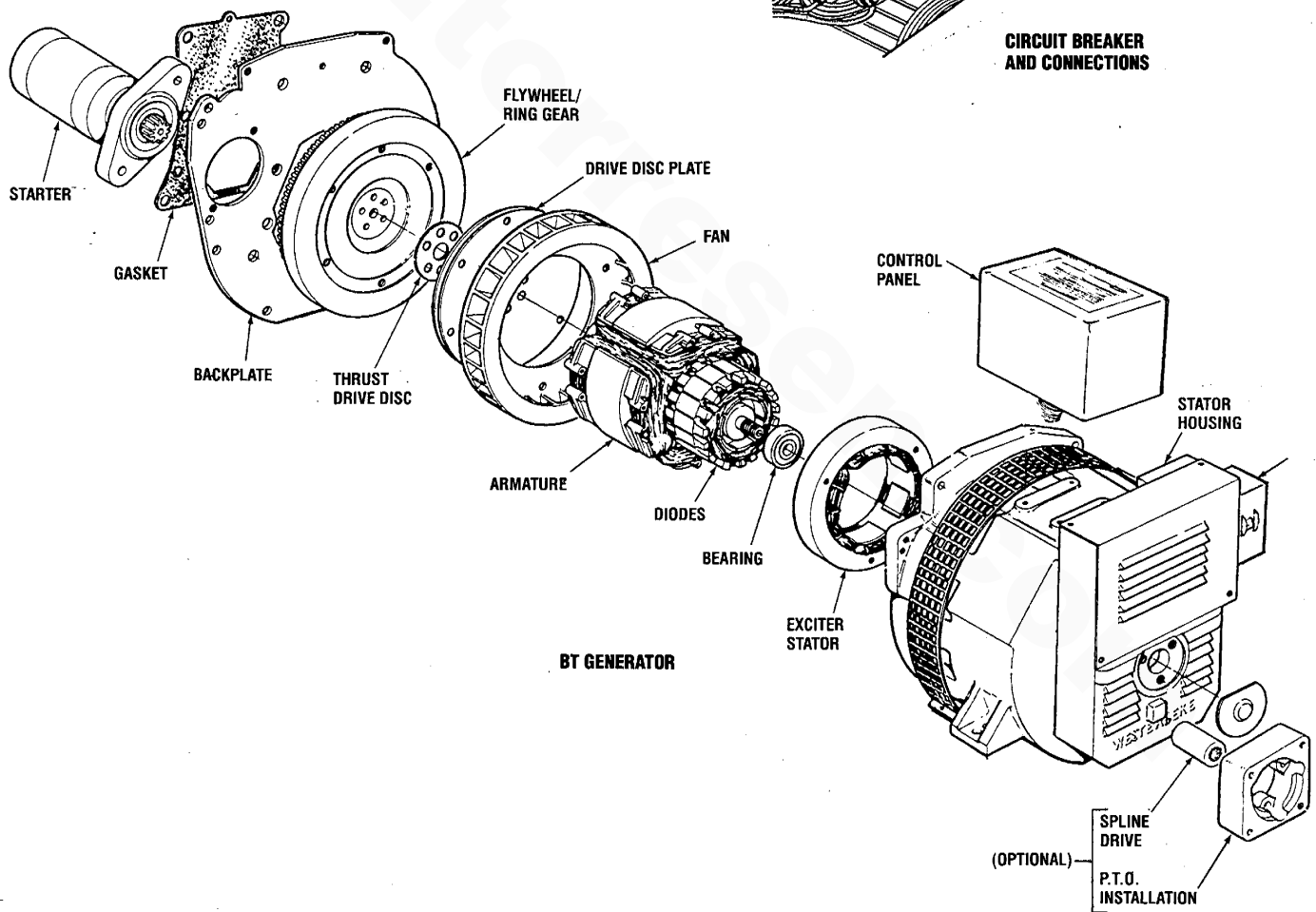
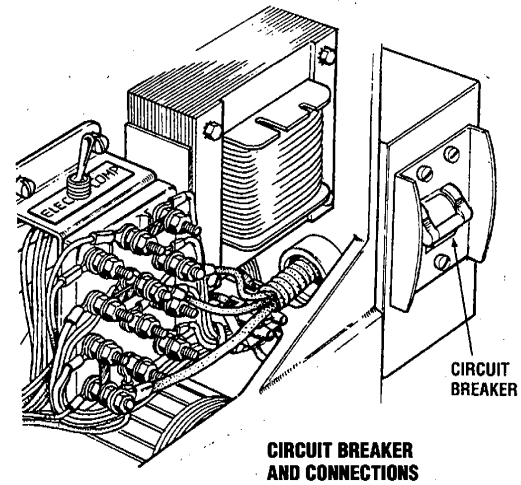

# DC ELECTRICAL SYSTEM

## WMD GENERATOR WIRING SCHEMATIC #24700

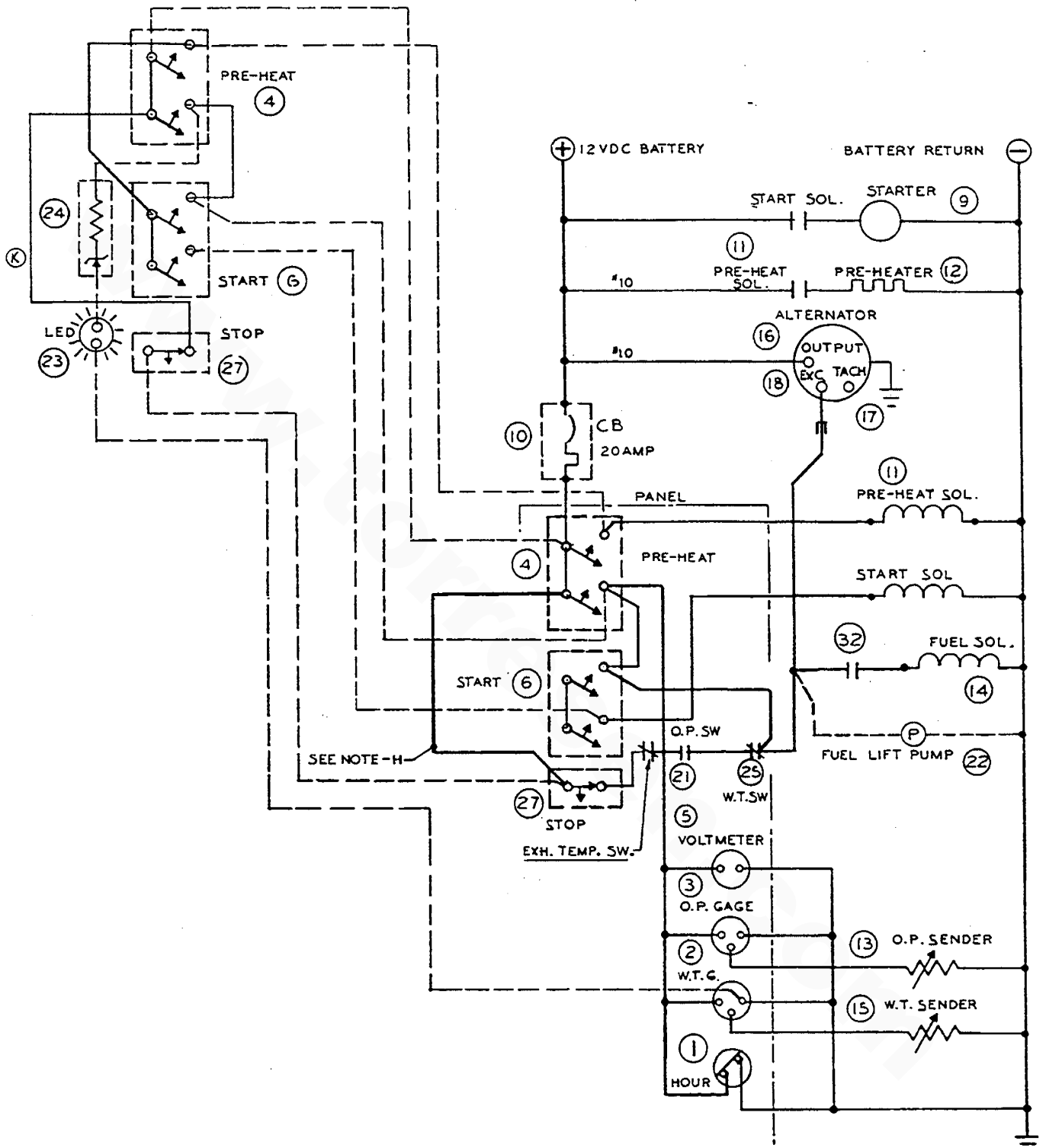

**DESCRIPTION**

This generator is a brushless self-excited generator, which requires only the driving force of the engine to produce AC output. The copper and laminated iron in the exciter stator are responsible for the self-exciting feature of this generator. The magnetic field creates an electromagnetic field which rotates through the windings of the main stator, inducing AC voltage which is supplied to a load. A transformer is connected in parallel to the AC output of the main stator. An AC voltage is produced in the auxiliary windings of the transformer and main stator and is, in turn, supplied to a full-wave bridge rectifier. The rectifier produces a DC voltage to further excite the exciter stator windings, enabling the generator to produce a rated AC output as the generator speed reaches its set hertz rpm.

An optional solid-state voltage regulator is available to work in tandem with the transformer regulator to produce a more stable AC output.

A circuit breaker is installed on all current WESTERBEKE generators. This circuit breaker will automatically disconnect generator power in case of an electrical overload. The circuit breaker can be manually shut off when servicing the generator to insure that no power is coming into the generator.

**NOTE:** This circuit breaker is available as a WESTERBEKE add-on kit for earlier model generators; contact your WESTERBEKE DEALER.

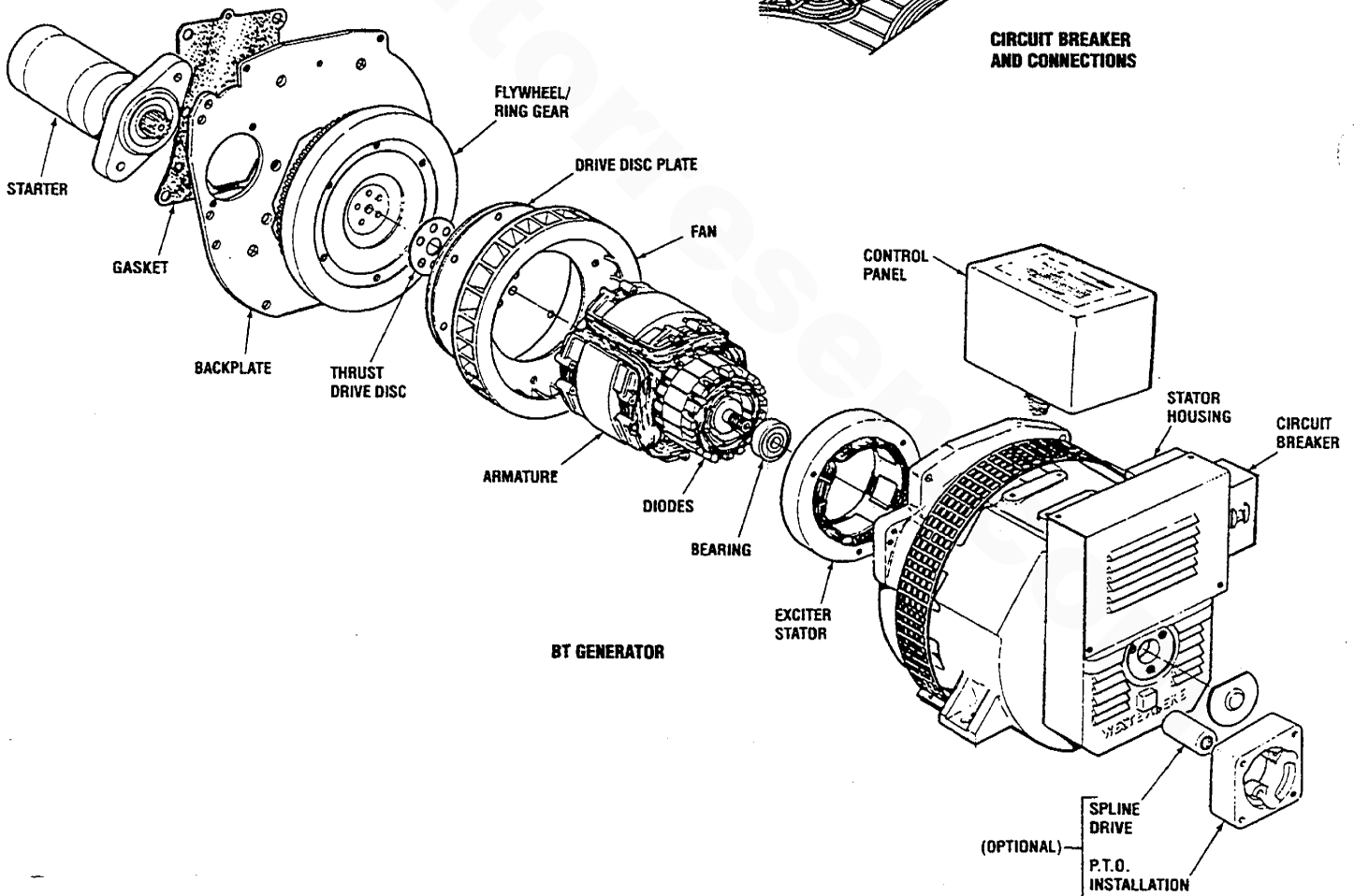
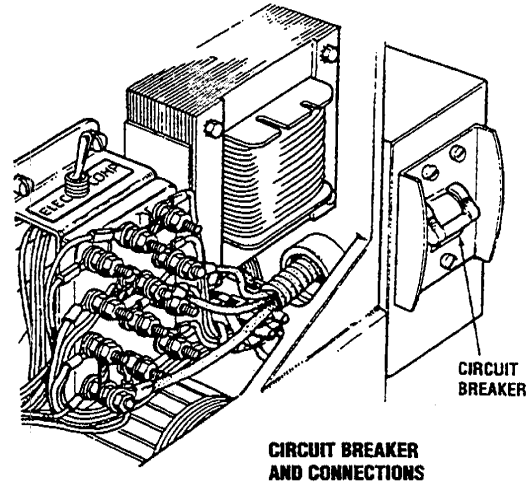

This troubleshooting guide will give you insights into problems which may be encountered with the WESTERBEKE BT brushless, transformer regulated generators. Most potential problems are covered in the text of this guide. Owing to the simplicity of the equipment and controls, this troubleshooting is relatively easy, once the relationship between cause and effect is understood.

Keep in mind that a basic fundamental knowledge of electricity is required for this troubleshooting, and always remember that lethal voltages are present in the circuitry; therefore, extreme caution is essential when working on or troubleshooting a generator.

Only a few basic tools are necessary for diagnosis and repair. These are hand tools: an amp probe and a quality volt ohm-meter capable of reading less than one ohm due to the precision required in reading component winding resistances.

**NOTE:** Do not always rely on the vessel's instruments for accurate readings; bring your own instruments for testing.

Before attempting any repairs, get as clear an explanation of the problem as possible, preferably from an individual witnessing the problem. In some cases, this may bring to light a problem which is related to the method of operation rather than an equipment fault.

Bring basic repair parts with you on the initial trip to the problem equipment, such as a regulator board when installed, diodes and a bridge rectifier, so that if the problem should be found in one of these easily replaceable parts, the problem can be remedied early and efficiently.

The internal and external wiring diagrams are important tools in troubleshooting this generator or any generator model. Be sure to have both with you and be sure they are for the specific model you will be working on. (e.g. Model 12.5 BTD).

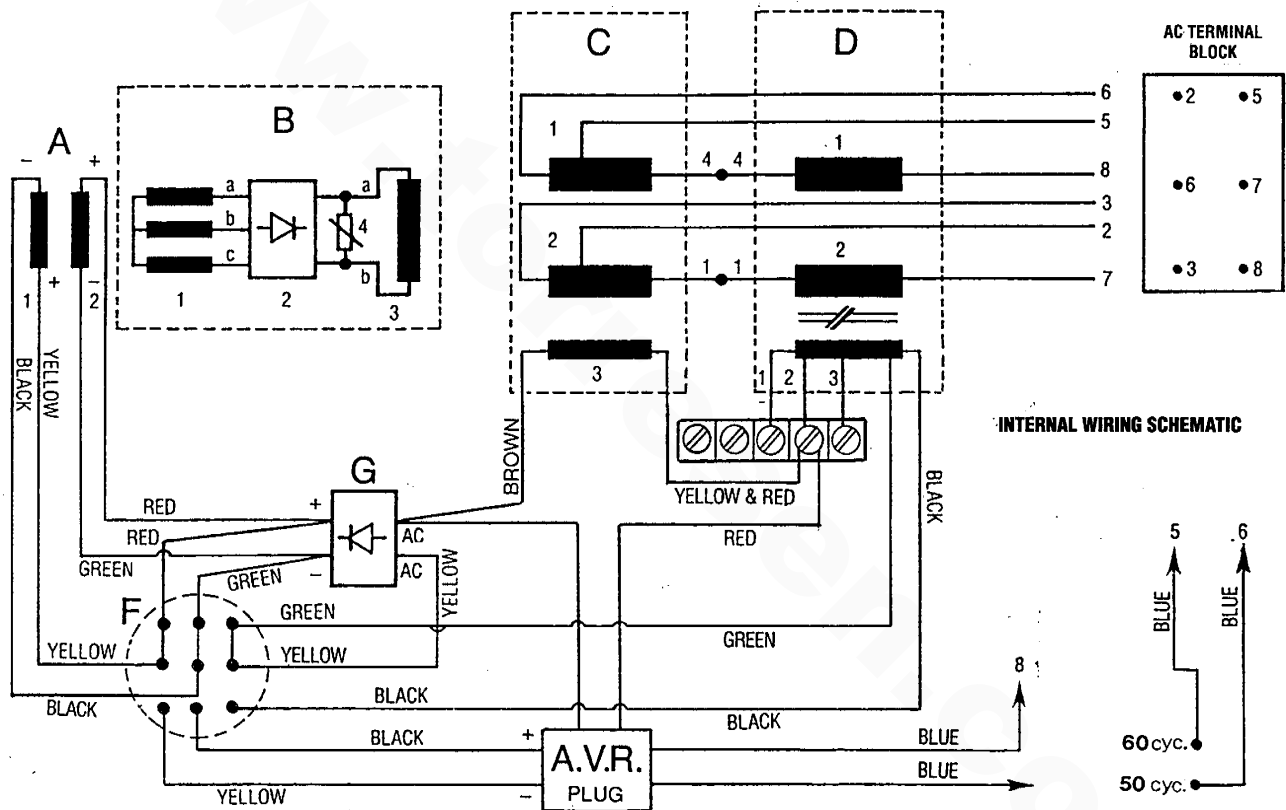

**A. EXCITER STATOR WINDINGS 1 & 2**  
 A-1 and A-2 Exciter Stator Windings  
 (Selector in COMP position)

**B. EXCITER ROTOR**  
 1. Auxiliary Windings (a-b-c)  
 2. Diodes (6)  
 3. Rotating Field Windings  
 4. Pozi-resistor

**C. MAIN STATOR**  
 1. Main Stator Windings  
 2. Main Stator Windings  
 3. Main Stator Auxiliary Windings

**D. COMPOUND TRANSFORMER**  
 1. Compound Transformer Windings  
 2. Compound Transformer Windings  
 3. Compound Transformer Auxiliary Windings with Voltage/Hertz Connection Bar

**E. SELECTOR SWITCH**  
 F-1 Compound  
 F-2 Electronic and Compound

**F. BRIDGE RECTIFIER WIRING**

A.V.R. Optional Automatic Voltage Regulator Plug (6 prong).



**NOTE:** The following is a list of faults with the generator operation on compound (COMP) transformer regulation (no A.V.R. installed).

FAULT	CAUSE	CORRECTION
Low Voltage (70 volts) at N/L and loss of voltage as load is applied (no loss of engine speed and hertz).	1. Selector switch in wrong position.	1. Place selector switch in COMP position.
High voltage at N/L (125 - 135 volts) with correct voltage when loaded (115 - 120 volts).	1. Generator's engine speed (rpm) high at N/L.	1. Check N/L speed and adjust N/L voltage.
High voltage at N/L and F/L.	1. Generator's engine speed (rpm) high. 2. Short in compound transformer auxiliary windings D-3.	1. Check N/L rpm and adjust N/L voltage. 2. Check continuity and connections of D-3 windings.
Low voltage at N/L (0 - 5 volts) with growling noise from generator and loss of engine speed when load is applied.	1. Main stator windings shorted C-1, C-2. 2. Compound transformer windings shorted D-1, D-2.	1. Check continuity and resistance values of C-1, C-2 windings and connections. Excite unit with 12 VDC. 2. Check continuity and resistance values of D-1, D-2 windings. Excite unit with 12 VDC.
Generator does not excite; voltage is 0 volts at N/L.	1. Generator's engine speed (rpm) is slow. 2. Short in the main stator windings or in transformer. 3. Failed diodes on exciter rotor. 4. Shorted pozi-resistor.	1. Adjust the engine's speed and adjust N/L voltage. 2. Excite the unit with 12 VDC. Short will appear as a load on the engine, growling of the generator. 3. Check the diodes on the exciter rotor. Four or more failed diodes will terminate the rotating field. 4. Visually examine the pozi-resistor on the exciter rotor. The shorted resistor will be burnt. This will short out the rotating field. Remove and test run.
Low voltage at N/L (10 - 20 volts); when load is applied, voltage drops.	1. Diodes(s) in rotating exciter (B-2) shorted. 2. Bridge rectifier defective. 3. Auxiliary windings B-1 shorted. 4. Auxiliary windings D-3 and/or C-3 open.	1. Check B-1 and B-2 in the rotating exciter as explained in this manual. 2. Follow test procedure for the bridge rectifier. 3. Check the continuity and resistance values. 4. Check the continuity and resistance values of windings and connections.
Voltage correct at N/L, but not at F/L with loss of engine rpm (hertz).	1. Selector switch in ELEC position. 2. Exciter stator windings A-1 and A-2 are open. 3. Generator's engine speed is low.	1. Place selector switch in COMP. 2. Check continuity and resistance values of A-2 windings. 3. Check generator N/L rpm and adjust N/L voltage.
Voltage correct at N/L, but not at F/L with loss of engine rpm (hertz).	1. Generator overload. 2. Low power factor load (motor loads) are open.	1. Check data plate and monitor load on generator with amp-probe. 2. Check type of load applied. Consider use of optional regulator board.
Unstable voltage.	1. Engine's rpm fluctuating.	1. Check the engine operation and the fuel system.
Low voltage at N/L and voltage drops further as a load is applied.	1. Diodes in exciter rotor shorted (B-2). 2. Auxiliary windings in exciter rotor shorted (B-2).	1. Check the diodes in the exciter rotor as illustrated in this manual. 2. Check the resistance values and continuity to ground.
Voltage OK at N/L and low at F/L.	1. Auxiliary windings in the exciter rotor. 2. Exciter stator compound windings A-2 is open. 3. Auxiliary windings D-3 or C-3 open.	1. Check resistance values and continuity to ground. 2. Check continuity and connection of windings. 3. Check continuity and connection of windings.
Voltage unstable.	1. Defective regulator board. 2. Engine is hunting. 3. Electrical connections.	1. Check stability of DC voltage from regulator to exciter stator windings. Operate unit on COMP. Replace regulator board. 2. Check engine operation and the fuel system. 3. Check for clean and secure connections.



**RESIDUAL VOLTAGE CHECK**

1. Residual Voltage 10-14 volts AC.

**NOTE:** The amount of no-load voltage produced by the generator can be an indicator of where in the generator the problem/fault may lie.

This voltage is the AC voltage produced by the generator from magnetism in the exciter stator field. This voltage is measured between the AC neutral and hot leg(s) with no-load on the generator running at 60 hertz.

The presence of residual voltage is an indication that the following generator components are OK:

1. Exciter Rotor (B-1 a, b, & C) & (B-2)
2. Rotating Field (B-3)
3. Main Stator (C-1 & C-2)
4. Compound Transformer (D-1 & D-2)

The fault lies in one or more of the following components in the exciter circuit:

- A. Exciter Stator (A-1 & A-2)
  - B. Bridge Rectifier (G)
  - C. Selector Switch (F)
  - D. Main Stator Auxiliary Windings (C-3)
  - E. Compound Transformer Auxiliary Winding (D-3)
2. Twelve (12) volts DC excitation of the exciter stator windings should cause the generator to produce between 140–150 volts AC between each hot lead and the neutral. (Twelve volts DC is applied between the lifted (+) and (-) leads of the bridge rectifier, + to + and - to -.) Correct voltage produced with twelve volts DC excitation indicates the fault is in one or more of the above listed components B, D or E. If the generator does not produce 140–150 volts AC, then include A and C.
  3. The absence of any voltage from the generator indicates a fault with the main stator windings C-1 and C-2 and/or the compound transformer windings D-1 and D-2. Other

failed components that can produce this same no-voltage output are the pozi-resistor in the exciter rotor and 4 or more failed diodes in the exciter rotor.

- a. Apply 12 volt DC excitation to the exciter stator windings as explained in paragraph 2. A fault in the main stator and/or compound transformer windings such as a short will cause the generator engine to load down and the shorted windings to eventually produce smoke as the excitation is continued.

4. Voltage output greater than residual and less than rated output (25–100 volts) indicates a fault in the exciter rotor/field B-1, B-2, B-3. Excitation of the generator as explained in paragraph 2 should produce a partial rise in voltage output and, when removed, the voltage will return to the original low output.

**BRIDGE RECTIFIER**

The bridge rectifier is supplied AC voltage from the auxiliary windings in the generator stator (C-3) and the compound transformer (D-3). The AC voltage measured across the AC terminals of the rectifier during engine operation is as follows:

<b>120 Volts</b>	<b>120/240</b>
N/L F/L	N/L F/L
10–20 volts AC	10–20 volts AC

Diodes in the rectifier convert this AC voltage to DC and supply it to the windings (A-1 and A-2) of the exciter stator to induce a field through which the exciter rotor revolves. The DC voltage measured across the (+) and (-) terminals of the bridge rectifier during engine operation is as follows:

<b>120 Volts</b>	<b>120/240</b>
N/L F/L	N/L F/L
10–20 volts AC	10–20 volts AC

Failure of the bridge rectifier will result in a weak field being produced by the exciter stator windings. A weak field is present, due to the magnetism in the exciter stator, which will cause the generator to produce residual voltage.

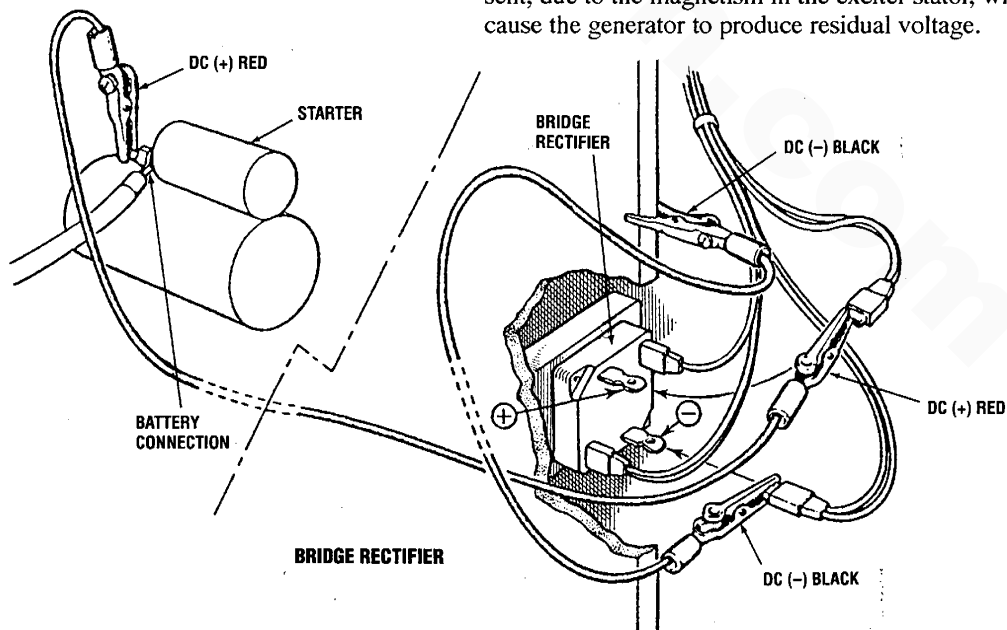

**Testing the Bridge Rectifier for Faults with an Ohmmeter**

1. Set the ohmmeter scale on RX1 (+DC). Zero the meter.
2. Connect the (+) lead from the meter to point #4. With the (-) lead from the meter, momentarily contact points #1, #2, #3, and #5. No deflection of the needle should occur, showing infinite resistance.
3. Remove the (+) lead from point #4 and connect the (-) lead to point #4 and, with the (+) lead, momentarily touch points #1, #2, and #3. The needle of the meter should deflect showing a passage of meter voltage through the diodes in the rectifier.
4. Touch point #5 with the (+) lead. No deflection of the needle should occur.
5. Place the (+) lead of the meter on point #1 and the (-) on point #3. No deflection of the needle should occur (infinite resistance). Reverse the connections and the same should occur.

**NOTE:** Different style/model meters may produce opposite results from the above tests.

Should the rectifier fail any of these tests, it is defective and should be replaced.

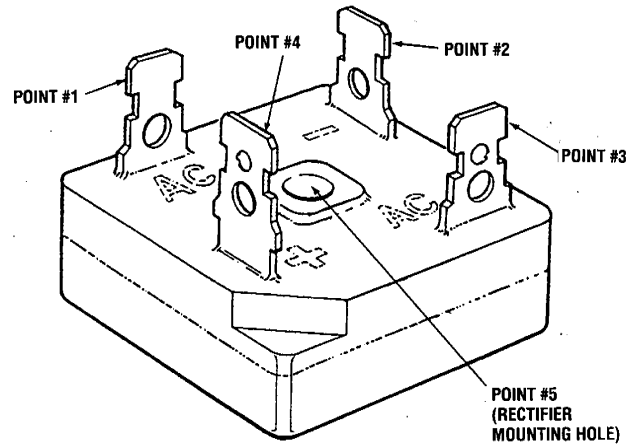

**INTERNAL WIRING DIAGRAM**

**NOTE:** The AC terminal block has studs for 1/4 inch wire terminal ends. Multi-strand copper wire should be used and sized for the amperage rating of the generator.

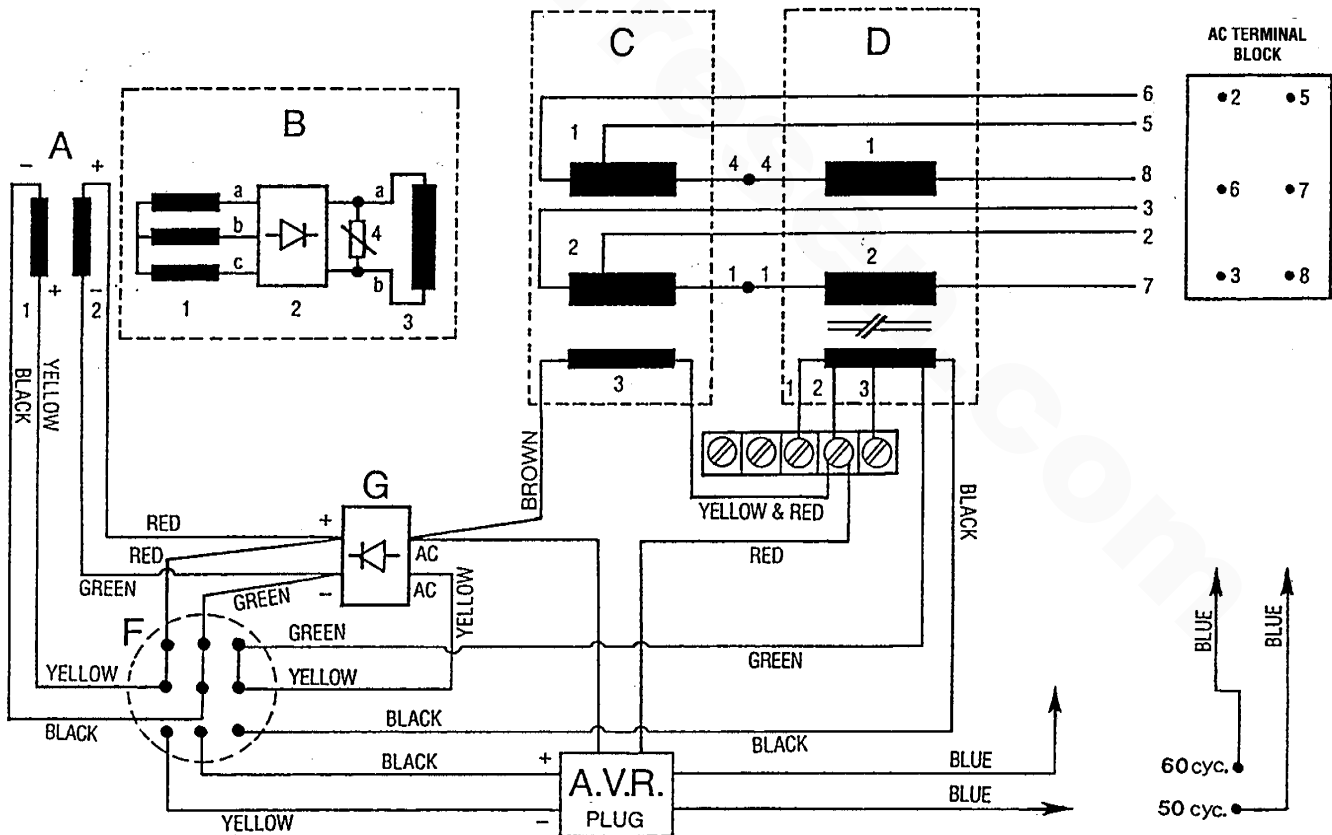



**COMPONENT RESISTANCE VALUES**

**NOTE:** Resistance Values — at 70°F (21°C)  
 (Simson Meter 260 Model).

**Models 11.0 & 12.5(A) BT**

- A. Exciter Stator**
  - A-1 & A-2 11.5 ohm
  - A-1 49.4 ohm
  - A-2 12.9 ohm
- B. Exciter Rotor/Field**
  - B-1 1.05 ohm
  - B-2 8.7 ohm
- C. Main Stator**
  - C-1 0.117 ohm
  - C-2 0.117 ohm
- D. Main Stator Auxiliary Windings**
  - C-3 0.99 ohm
- E. Compound Transformer**
  - D-1 0.007 ohm
  - D-2 0.007 ohm
- Transformer Auxiliary Windings**
  - D-3 5.02 ohm

**NOTE:** BT model generators are used on models rated lower than the capabilities of the generator. However, the generator is rated according to the capabilities of the drive engine since horsepower produces kilowatts.

**COMPONENT RESISTANCE CHECKS**

**Exciter Stator Windings**

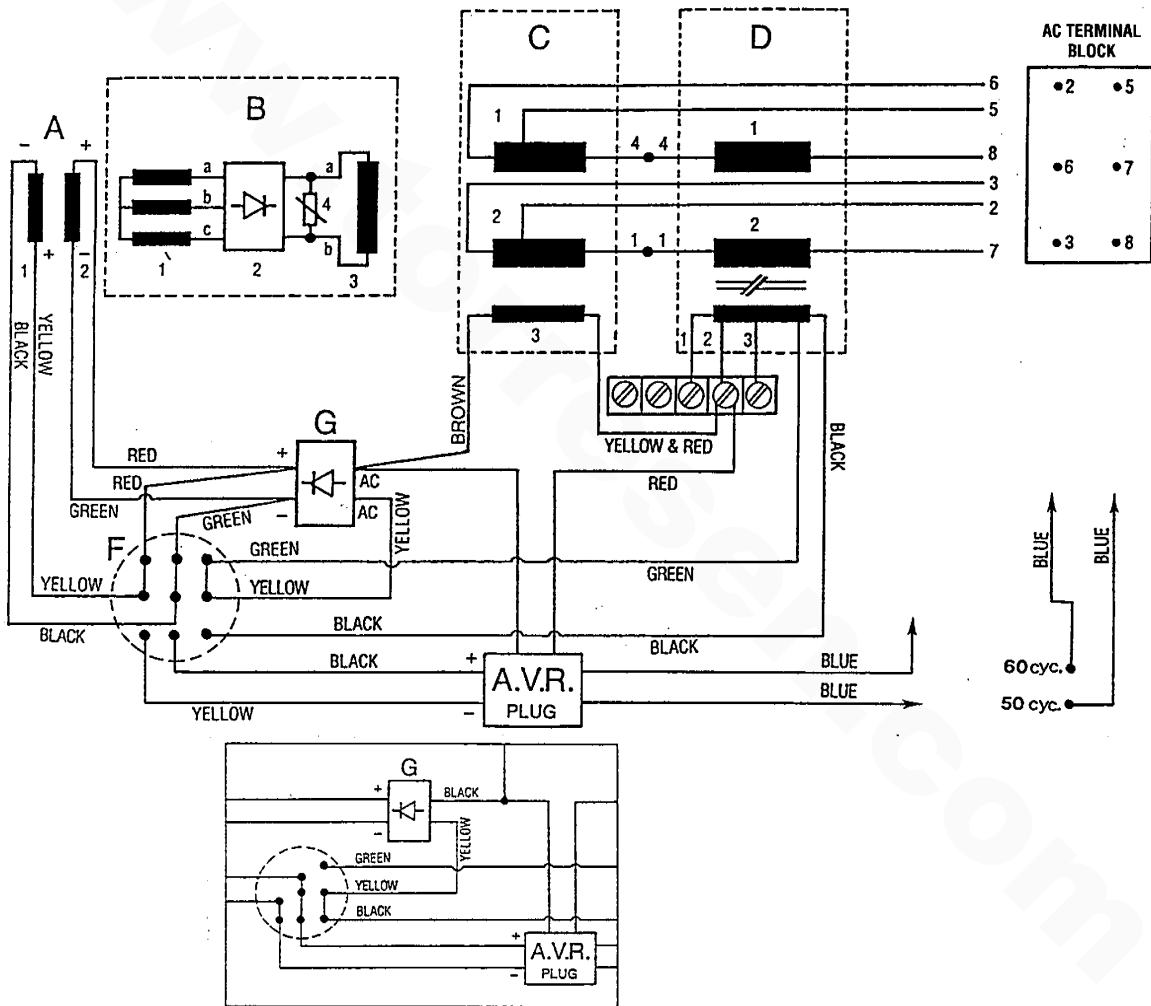

**A Windings 1 & 2**

Resistance readings for exciter windings A-1 and A-2 with the selector switch in the COMP position are taken between the positive (+) and negative (-) leads lifted off the bridge rectifier (G). Neither of these two leads should have continuity to the generator case/ground.

**A Winding 1**

Resistance reading for exciter winding A-1 with the selector switch in the ELEC position is taken between the yellow & white striped wire and the black & white striped wire at the A.V.R. plug.

**A Winding 2**

Resistance readings for exciter winding A-2 with selector switch in the ELEC position is taken between the green & white striped wire lifted off the (-) terminal of the bridge rectifier (G) and the red & white striped wires lifted off the (+) terminal of the bridge rectifier (G).



**EXCITER ROTOR/FIELD**

**Auxiliary windings group a, b and c.** Locate the three terminal points on the exciter rotor for these auxiliary winding groups. Position the exciter rotor as shown in the illustration and count off the porcelain knobs from the 12 o'clock point either left or right to locate terminal points a, b and c. Measure the resistance value between the pairs of terminal points A & B, B & C, and C & A. There is no need to unsolder these connections unless a faulty reading appears. If this occurs, unsolder and verify the winding fault. There should be no continuity found between any of the three terminal points and the rotor shaft/case ground.

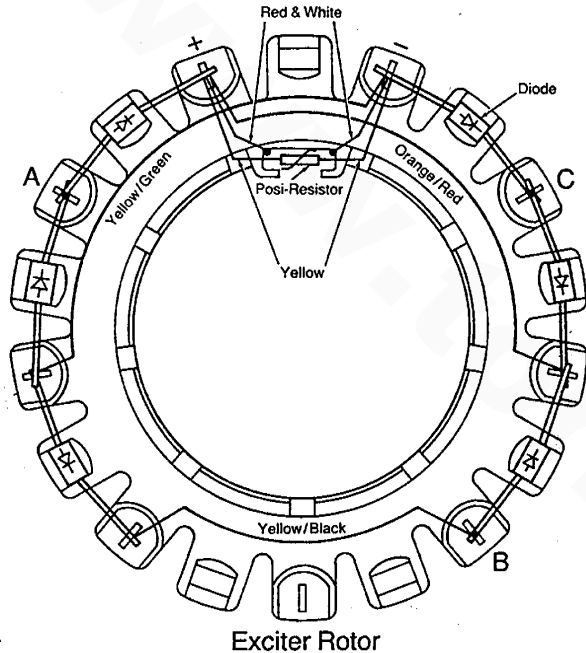

**Rotating Field Windings.** See the illustration of the exciter rotor. The field winding connections are noted as the (+) and (-) connections of the red & white striped wires. Measure the resistance value with your ohmmeter between these two connection points. These connections need not be unsoldered unless a faulty reading appears. If this occurs unsolder the connection and verify the resistance reading. With these connections lifted, there should be no continuity to the rotor shaft. This would indicate a short to ground with these field windings.

**Diodes.** Six diodes are mounted on the exciter rotor; they rectify the AC voltage produced by the three groups of auxiliary windings to DC voltages and supply this DC voltage to the rotating field windings.

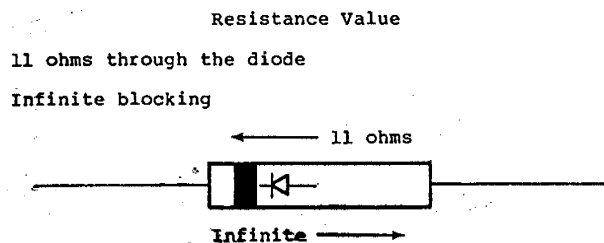

The diodes can be easily checked in place with the use of a common automotive 12-volt high beam headlight bulb, some jumper leads and the generator's 12 volt starting battery.

A short or an open in a diode can easily be found with the above without having to unsolder and isolate each diode to check it with an ohmmeter.

**NOTE:** Attempting to check diodes in place with an ohmmeter will give erroneous readings on the diodes due to the auxiliary winding's connections.

When leads are put across the diode, as illustrated, voltage passes through the diode allowing the headlight to glow brightly.

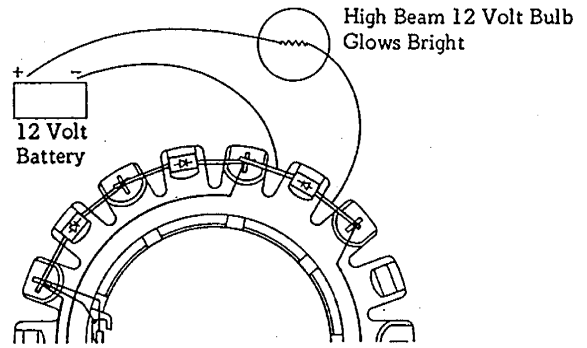

**Reverse the leads across the diode.** The diode should block voltage passing through it, and the headlight should not glow, or it may glow faintly.

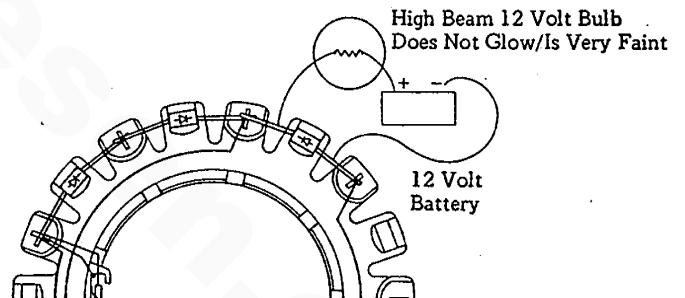

- a. Should the bulb not glow with leads connected in both directions, the diode is open internally.
- b. Should the bulb glow with leads connected in both directions, the diode is shorted internally.

In both a and b above, the diode should be replaced. Check the resistance values of the rotating field windings and the integrity of the resistors connected between the field windings.

**Rotating Field Windings 7.0–8.0 ohm.** (Reading taken between the two red & white wires connected to the (+) and (-) terminals of the exciter rotor as shown in the illustration.)

**Posi-resistor.** (Infinite readings between both yellow leads lifted from the (+) and (-) terminals on the exciter rotor.)

**MAIN STATOR WINDINGS**

- Group #1.** The resistance value is measured between the lifted lead #4 from the red insulated terminal below the transformer and lead #6 lifted from the AC terminal block. Also lifted from the AC terminal block is lead #5 so as to totally isolate the stator windings of group #1 (see illustration).
- Group #2.** The resistance value is measured between the lifted lead #1 from the red insulated terminal below the transformer and lead #3 lifted from the AC terminal block. Also lifted from the AC terminal block is lead #2 so as to totally isolate the stator windings of group #2 (see illustration).

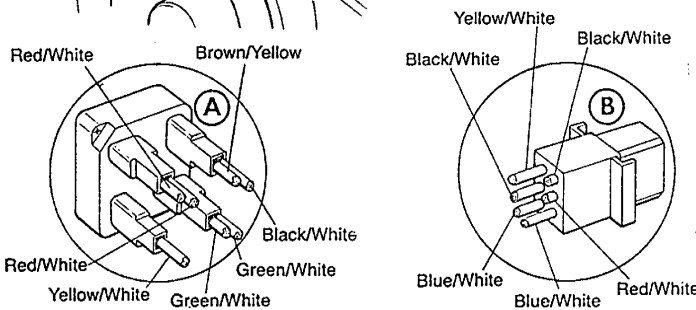
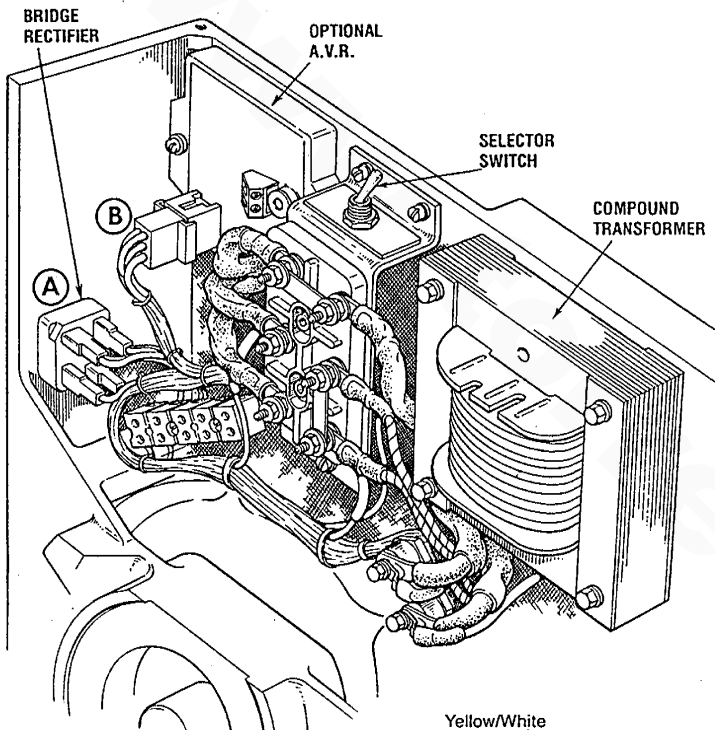

NOTE: ON LATER MODELS, THE WHITE STRIPE ON THE WIRE WAS REMOVED, AND THE WIRE IS A SOLID COLOR.

NOTE: There should be no continuity found between any of the lifted stator leads and the case ground. Also, no continuity should be found between the connections of the two groups.

- Main Stator Auxiliary Windings.** The resistance value for these windings is measured between the black & white and the brown & yellow double lead connection

lifted off the AC terminal of the bridge rectifier (G) and the yellow & red striped lead lifted off the Voltage/Hertz Connection Bar. There should be no continuity found between these winding connections and the case/ground as well as the two main stator groups.

NOTE: The Voltage/Hertz Connection Bar is located below and just to the left of the AC terminal block.

**COMPOUND TRANSFORMER**

- Group #1.** Resistance value is measured between the lifted lead #1 from the red insulated terminal stud below the transformer and lead #7 lifted off the AC terminal block.
- Group #2.** Resistance value is measured between the lifted lead #1 from the red insulated terminal stud below the transformer and lead #7 lifted off the AC terminal block.

NOTE: None of the lifted leads should have a continuity to the case/ground nor should either of the groups have continuity to the other.

- Transformer Auxiliary Windings.** Resistance value is measured between the yellow & white striped wires lifted off the AC terminal of the bridge rectifier (G) with the selector switch in the ELEC position and the #1 red & white striped leads lifted off the Voltage/Hertz Connection Bar. Off this same bar, lift the #2 and #3 red & White striped leads that come from the auxiliary windings to totally isolate these windings. There should be no continuity found from either of these connections to the case/ground or to either of the two transformer groups.

**SELECTOR SWITCH**

Selector switch F-2 ELEC (electronic A.V.R. and compound transformer). This is the optional configuration of the exciter circuit with the optional A.V.R. installed.

NOTE: With the selector switch in ELEC F-2 position in which the exciter stator windings are divided, one group is excited through the bridge rectifier and the other group through the A.V.R.

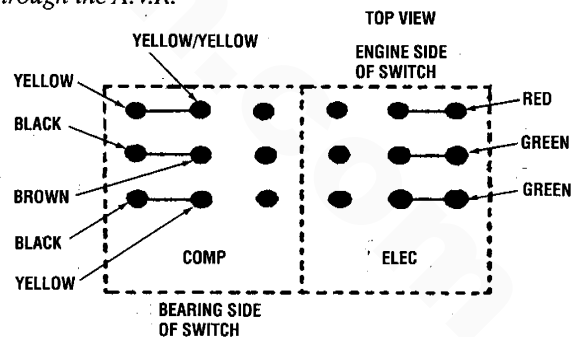

**BRIDGE RECTIFIER WIRING**

The illustration shows the color-coded striped wires at the two AC terminals and the color-coded wires at the (+) and (-) DC terminals.

NOTE: When removing or reinstalling connections, maintain correct polarity connection on the (+) and (-) DC terminals.



### NO-LOAD VOLTAGE ADJUSTMENT

Voltage adjustment is made with the generator regulation being governed by the compound transformer.

1. The selector switch **must** be in the COMP position.
2. Operate the generator, apply a moderate load momentarily and remove it. Note the voltage output from the generator's 120 volt leg(s) (220 volt 50 hertz). The no-load voltage should be between 121–124 volts at 61.5–62 hertz (222–226 volts at 51.5–52 hertz).

**NOTE:** The no-load voltage should be adjusted to the voltage produced by the generator once started, and a momentary load should be applied to excite the transformer, and then removed. The voltage produced by the generator after this momentary load is removed is no-load voltage.

3. To raise or lower the voltage, shims of varying thickness (non-conductive material) are placed or removed from under the steel laminated bar on top of the compound transformer. The material used for shimming should not soften at temperatures in the 176°F (80°C) range. A small reduction in no-load voltage (1 at 3 volts) can sometimes be accomplished by gently tapping the top of the laminated steel bar to reduce the gap between the existing shims and the transformer core.

Varying shim thickness by .001 inch (0.025 mm) will change the no-load voltage by 4–6 volts. (Adding shim thickness will raise voltage; lessening shim thickness will lower voltage.)

### VOLTAGE/HERTZ CONNECTION BAR

1. Locate the Voltage/Hertz Connection Bar.
2. Refer to the illustration.
3. Connect the blue & white striped wire to either connection (A) or (B) to correspond to the hertz that the generator will be set to produce.

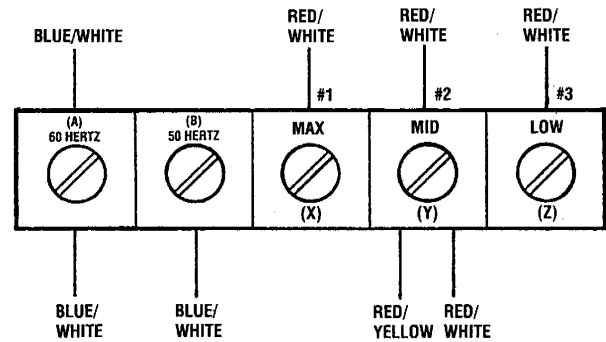

**NOTE:** On some units A and B may be reversed. To ensure a proper connection, be sure the blue & white striped leads coming off A or B go to the numbered terminal stud on the AC terminal block — #5 for 60 hertz and #6 for 50 hertz.

**NOTE:** The placement of the blue & white wire from connection (A) to (B) or vice versa when converting to 50 Hz is only accomplished when the optional voltage regulator is installed as well. Disregard this wire connection change if there is no voltage regulator installed.

4. Connections X, Y and Z are used to increase AC voltage to the bridge rectifier under heavy AC amperage loads the generator is supplying. When this connection is moved from X to Y or Z to increase AC output voltage under load, it will effect no-load voltage, and a no-load adjustment using the compound transformer will be needed.

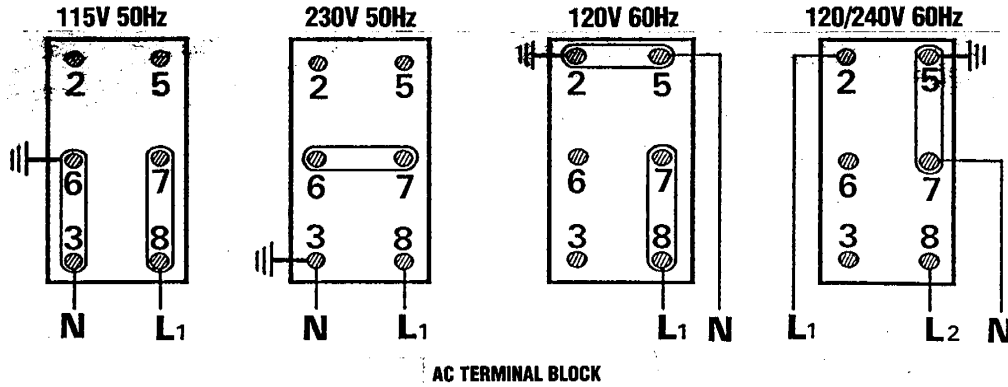

**NOTE:** The frame ground wire must be moved when changing from 120 volts and 120/240 volts 60 hertz to 220 volts 50 hertz. For making connections to the AC terminal block, use terminal ends for 1/4" studs that will accept multi-strand copper wire sized for the amperage rating from the hot lead connection.

**GENERATOR FREQUENCY**

1. Frequency is a direct result of engine/generator speed: 1800 rpm = 60 hertz; 1500 rpm = 50 hertz.
2. To change generator frequency, follow this procedure:
  - a. Connect the AC output leads to the AC terminal block, following the diagrams.
  - b. On the Voltage/Hertz Bar, reposition the blue & white striped lead to A or B to correspond to the hertz selected. Note – this need only be performed when a voltage regulator is installed.
  - c. Start the engine, monitor the voltage and adjust the engine no-load speed. Adjust the diesel units by the linkage between the throttle arm and fuel solenoid.
    - 60 hertz: no-load speed, 61.5–62.0 hertz
    - 50 hertz: no-load speed, 51.5–52.0 hertz
  - d. After the no-load hertz adjustment is made, the no-load voltage may need to be readjusted. In most cases, if the generator was producing the correct no-load voltage at the previous hertz setting, it would be correct at the changed hertz setting.

In the event it needs adjustment, adjust the shim thickness under the laminated steel bar of the transformer.

- 60 hertz: no-load voltage, 121–124 volts
- 50 hertz: no-load voltage, 114–118 volts  
232–238 volts

- e. Load the generator to the rated amperage output corresponding to the hertz speed of the generator.

**Rated Loaded Speed:**

- 60 hertz: loaded speed, 58.5–59.0 hertz
- 50 hertz: loaded speed, 48.5–49.0 hertz

**Maximum voltage drop acceptable at full rated output (amps):**

- 60 hertz: 108–110 volts
- 50 hertz: 215–220 volts

Should the voltage drop below the proper rate, loaded excitation can be increased to raise this voltage by repositioning connections on the Voltage/Hertz Connection Bar. Repositioning the two leads (red & white and yellow & white) from Z to Y or X will increase the loaded voltage out progressively in that order.

**NOTE:** No-load voltage may be effected needing readjustment with the compound transformer. Do not use these adjustments to compensate for overload conditions being placed on the generator/engine (inductive motor type loads). Loss of generator hertz speed, the result of overload, will cause a drop in voltage output.

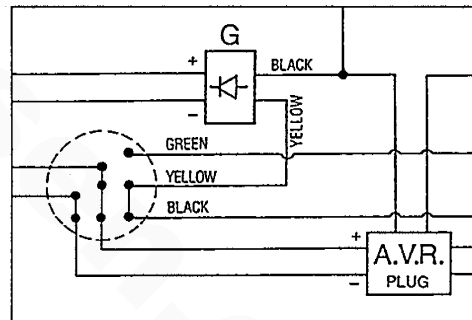

**INTERNAL WIRING SCHEMATIC**

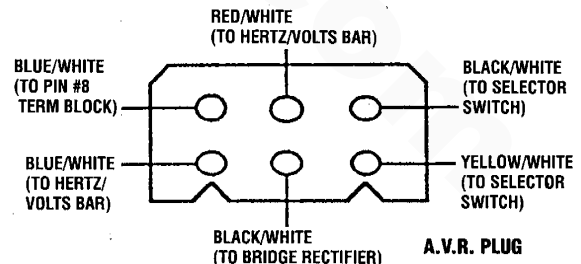

**NOTE:** The voltage regulator was optional on early models but is not available on later models.

# BT GENERATOR 6 TERMINAL BLOCK

## WIRING CONNECTIONS

### Winding Connections Needed to Obtain the Proper Voltage and Frequency

**NOTE:** Connections 1 and 4 are located on two red terminals below the compound transformer.

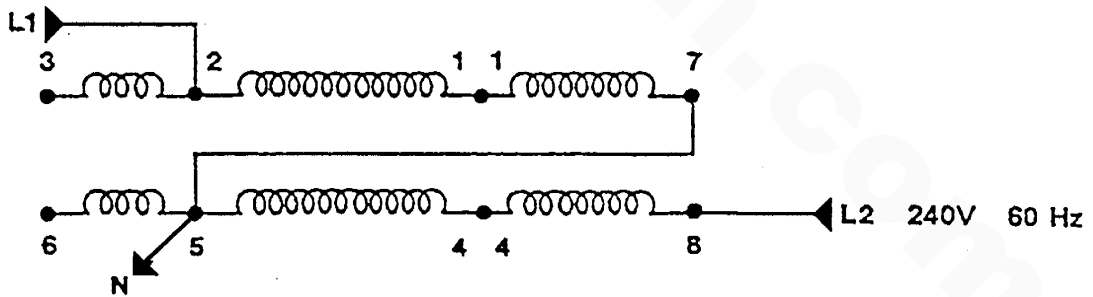
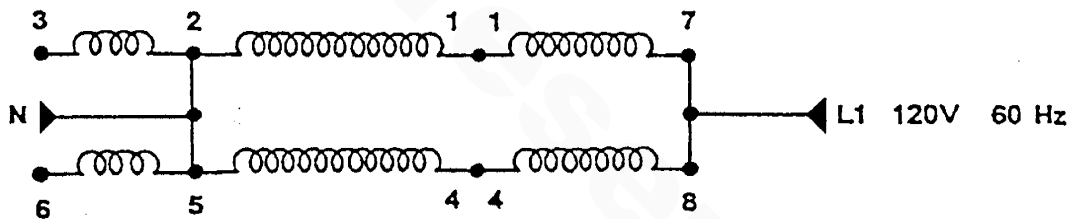
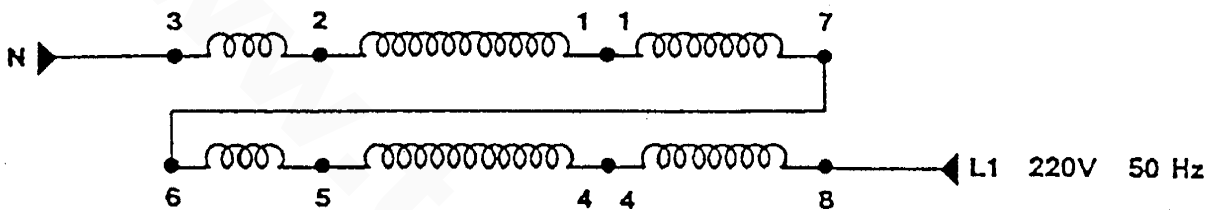
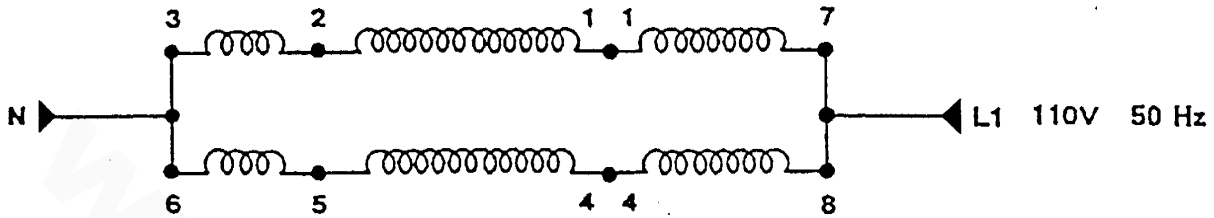

**6 TERMINAL BLOCK**  
winding connections needed to obtain  
the voltage and frequency.

**NOTE:** Connections 1 and 4 are located on two red  
terminals below the compound transformer.



[www.torresen.com](http://www.torresen.com)



# DC ELECTRICAL SYSTEM

## BT GENERATOR WIRING DIAGRAM #34651

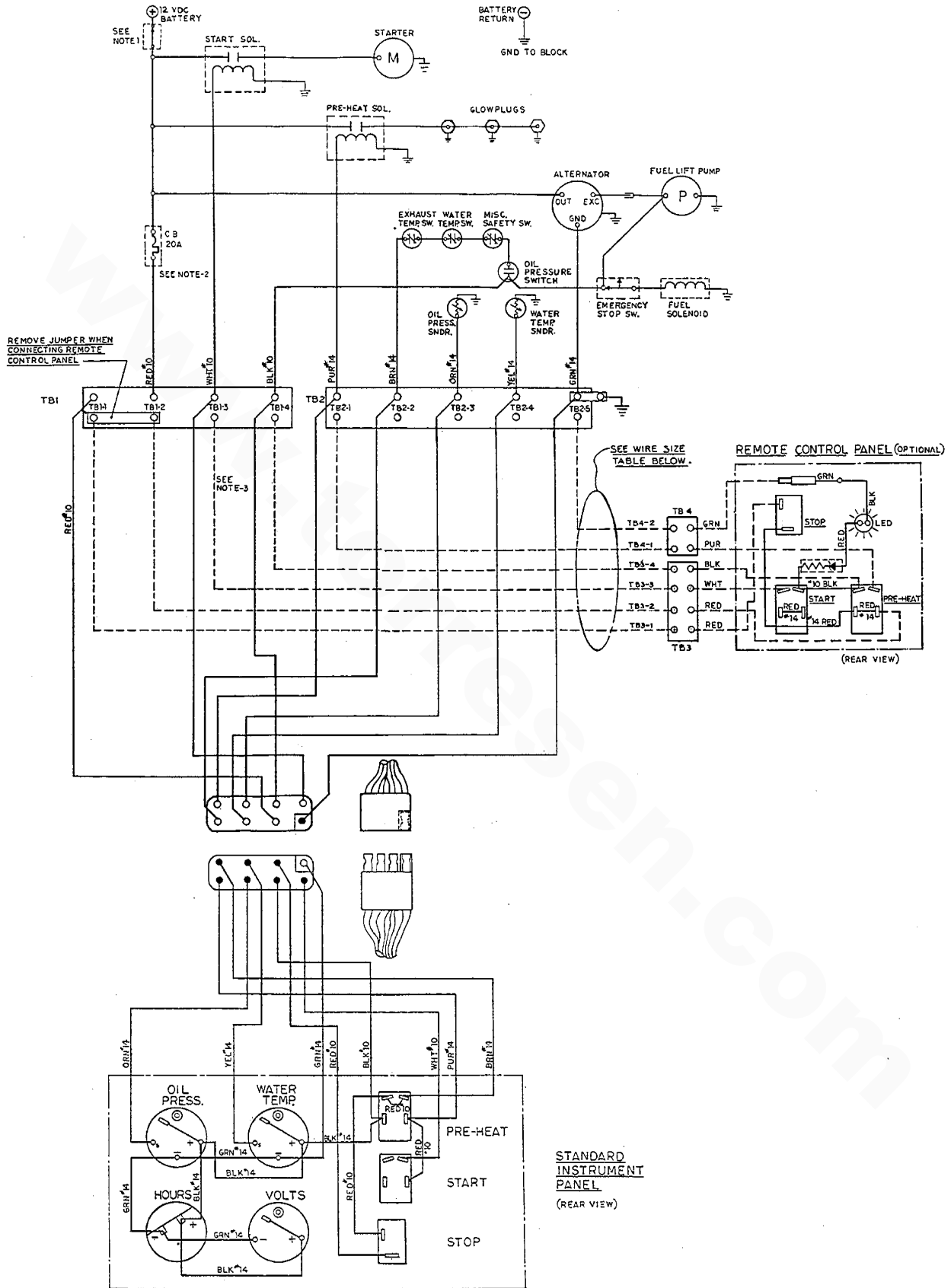

(continued)





# DC ELECTRICAL SYSTEM

## BT GENERATOR WIRING DIAGRAM #34651

- ① AN ON-OFF SWITCH SHOULD BE INSTALLED IN THIS CIRCUIT TO DISCONNECT THE STARTER FROM THE BATTERY IN AN EMERGENCY & WHEN LEAVING THE BOAT. TWELVE VOLT DIESEL ENGINE STARTERS TYPICALLY DRAW 200 TO 300 AMPS WHEN CRANKING. THE DURATION OF INDIVIDUAL CRANKING CYCLES SHOULD NOT EXCEED 30 SECONDS. A SWITCH WITH A CONTINUOUS RATING OF 175 AMPS AT 12 VDC WILL NORMALLY SERVE THESE FUNCTIONS BUT A SWITCH MUST NEVER BE USED TO MAKE THE STARTER CIRCUIT.
  
- ② THIS PRODUCT IS PROTECTED BY A MANUAL RESET CIRCUIT BREAKER LOCATED NEAR THE STARTER AND AS CLOSE TO THE SOURCE OF CURRENT AS POSSIBLE. EXCESSIVE CURRENT DRAW ANYWHERE IN THE INSTRUMENT PANEL, WIRING OR ENGINE WILL CAUSE THE BREAKER TO TRIP. IN THIS EVENT MOST GENERATORS WILL SHUT DOWN BECAUSE THE OPENED BREAKER DISCONNECTS THE FUEL SUPPLY. THEREFORE THE BUILDER/OWNER MUST BE SURE THAT THE INSTRUMENT PANEL WIRING AND ENGINE ARE INSTALLED TO PREVENT CONTACT BETWEEN ELECTRICAL DEVICES AND SALT WATER.
  
- ③ MOST STARTER SOLENOIDS DRAW 15 AMPS. THEREFORE THE VOLTAGE DROP IN THIS CONDUCTOR MUST BE NO GREATER THAN 10%. (IN THE PATH FROM THE STANDARD START SWITCH TO ANY REMOTE SWITCHES AND BACK TO THE STANDARD STARTER SWITCH). IF THIS REQUIRES IMPRACTICALLY LARGE CONDUCTORS THEN A RELAY MAY BE ADDED TO CONTROL THE STARTER SOLENOID ITSELF.

### GENERATOR OPERATION

PRE-HEAT: DEPRESS PRE-HEAT SWITCH FOR 15 TO 60 SECONDS AS REQUIRED.

START: DEPRESS BOTH PRE-HEAT AND START SWITCHES (PRE-HEAT ALSO OVERRIDES LOW OIL PRESSURE SHUTDOWN CIRCUIT). WHEN GENERATOR STARTS RELEASE START SWITCH ONLY. CONTINUE HOLDING PRE-HEAT SWITCH FOR A FEW SECONDS (UNTIL OIL PRESSURE REACHES 20 PSI).

STOP: DEPRESS STOP SWITCH UNTIL THE GENERATOR STOPS COMPLETELY.

### ② WIRING SIZES TO REMOTE CONTROL PANEL

<u>TERMINALS</u>	<u>0-16'</u>	<u>16-20'</u>	<u>20-25'</u>	<u>25-32'</u>	<u>32-40'</u>	<u>40-50'</u>	<u>50-65'</u>
TB1-1 TO TB3-1	#12	#10	#10	#9	#8	#7	#6
TB1-2 TO TB3-2	14	12	12	10	10	9	8
TB1-3 TO TB3-3	12	10	10	9	8	7	6
TB1-4 TO TB3-4	16	16	16	16	16	16	16
TB2-1 TO TB4-1	16	16	16	16	16	16	16
TB2-5 TO TB4-2	16	16	16	16	16	16	16





# DC ELECTRICAL SYSTEM

## BT GENERATOR WIRING SCHEMATIC #36412

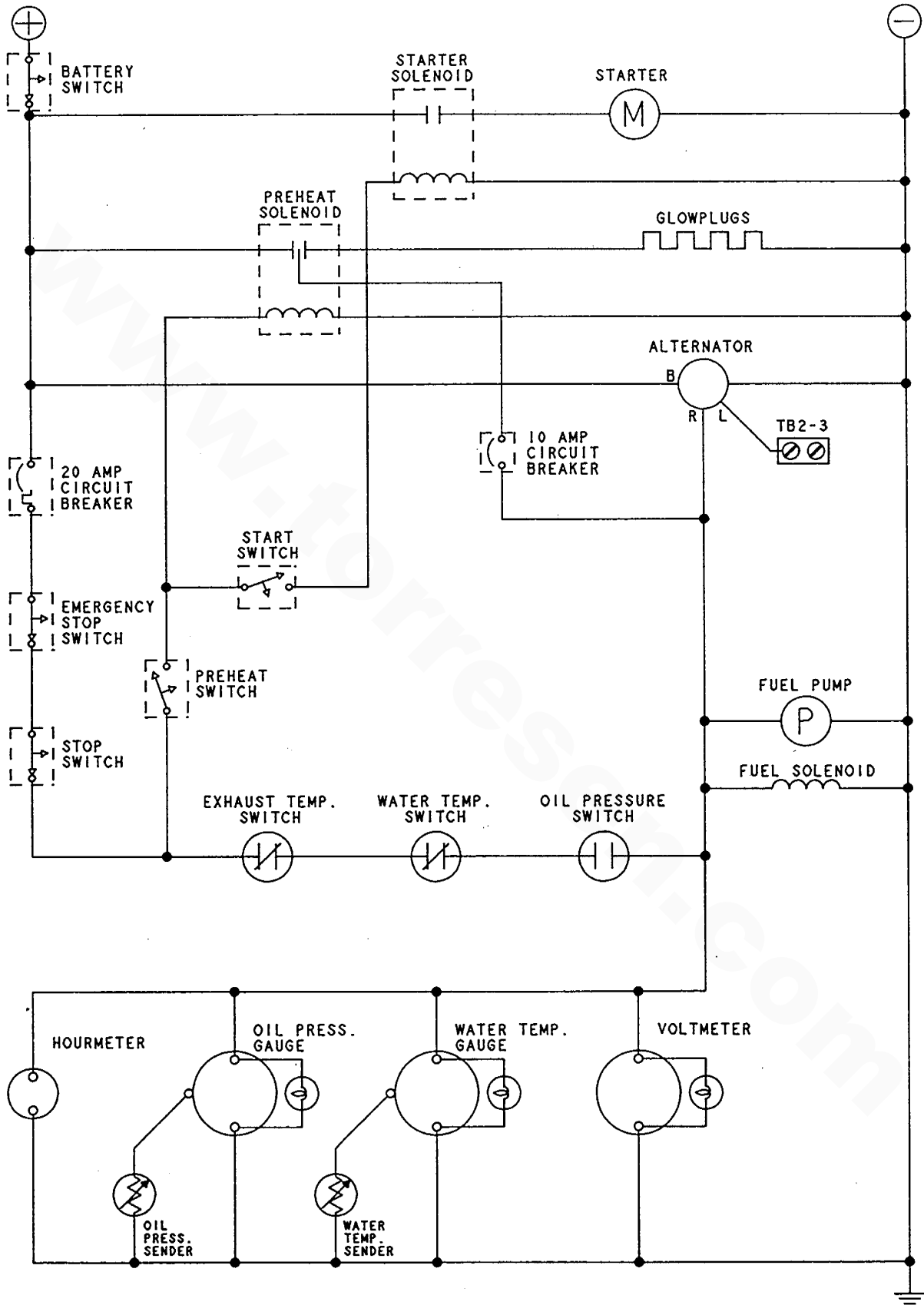

[www.torresen.com](http://www.torresen.com)

[www.torresen.com](http://www.torresen.com)



[www.torresen.com](http://www.torresen.com)