



SERVICE MANUAL

90A FOUR MARINE DIESEL ENGINE

and

32.0 KW-60 Hz BEDA

25.0 KW-50 Hz BEDA

MARINE DIESEL GENERATORS

SINGLE AND THREE PHASE

PUBLICATION NO. 43750
1st Edition/September 2000



WESTERBEKE CORPORATION • 150 JOHN HANCOCK ROAD
MYLES STANDISH INDUSTRIAL PARK • TAUNTON, MA 02780
WEBSITE: WWW.WESTERBEKE.COM

 *Member National Marine Manufacturers Association*

**CALIFORNIA
PROPOSITION 65 WARNING**
Diesel engine exhaust and some of its constituents are known to the State of California to cause cancer, birth defects, and other reproductive harm.

⚠ WARNING

Exhaust gasses contain Carbon Monoxide, an odorless and colorless gas. Carbon Monoxide is poisonous and can cause unconsciousness and death. Symptoms of Carbon Monoxide exposure can include:

- *Dizziness*
- *Nausea*
- *Headache*
- *Weakness and Sleepiness*
- *Throbbing in Temples*
- *Muscular Twitching*
- *Vomiting*
- *Inability to Think Coherently*

IF YOU OR ANYONE ELSE EXPERIENCE ANY OF THESE SYMPTOMS, GET OUT INTO THE FRESH AIR IMMEDIATELY. If symptoms persist, seek medical attention. Shut down the unit and do not restart until it has been inspected and repaired.



This WARNING DECAL is provided by WESTERBEKE and should be fixed to a bulkhead near your engine or generator.

WESTERBEKE also recommends installing CARBON MONOXIDE DETECTORS in the living/sleeping quarters of your vessel. They are inexpensive and easily obtainable at your local marine store.

SAFETY INSTRUCTIONS

INTRODUCTION

Read these safety instructions carefully. Most accidents are caused by failure to follow fundamental rules and precautions. Know when dangerous conditions exist and take the necessary precautions to protect yourself, your personnel, and your machinery.

The following safety instructions are in compliance with the American Boat and Yacht Council (ABYC) standards.

PREVENT ELECTRIC SHOCK

⚠ WARNING: Do not touch AC electrical connections while engine is running, or when connected to shore power. Lethal voltage is present at these connections!

- Do not operate this machinery without electrical enclosures and covers in place.
- Shut off electrical power before accessing electrical equipment.
- Use insulated mats whenever working on electrical equipment.
- Make sure your clothing and skin are dry, not damp (particularly shoes) when handling electrical equipment.
- Remove wristwatch and all jewelry when working on electrical equipment.
- Do not connect utility shore power to vessel's AC circuits, except through a ship-to-shore double throw transfer switch. Damage to vessel's AC generator may result if this procedure is not followed.
- Electrical shock results from handling a charged capacitor. Discharge capacitor by shorting terminals together with an insulated tool.

PREVENT BURNS — HOT ENGINE

⚠ WARNING: Do not touch hot engine parts or exhaust system components. A running engine gets very hot!

- Always check the engine coolant level at the coolant recovery tank.

⚠ WARNING: Steam can cause injury or death!

- In case of an engine overheat, allow the engine to cool before touching the engine or checking the coolant.

PREVENT BURNS — FIRE

⚠ WARNING: Fire can cause injury or death!

- Prevent flash fires. Do not smoke or permit flames or sparks to occur near the carburetor, fuel line, filter, fuel pump, or other potential sources of spilled fuel or fuel vapors. Use a suitable container to catch all fuel when removing the fuel line, carburetor, or fuel filters.
- Do not operate with a Coast Guard Approved flame arrester removed. Backfire can cause severe injury or death.
- Do not operate with the air cleaner/silencer removed. Backfire can cause severe injury or death.
- Do not smoke or permit flames or sparks to occur near the fuel system. Keep the compartment and the engine/generator clean and free of debris to minimize the chances of fire. Wipe up all spilled fuel and engine oil.
- Be aware — diesel fuel will burn.

PREVENT BURNS — EXPLOSION

⚠ WARNING: Explosions from fuel vapors can cause injury or death!

- Follow re-fueling safety instructions. Keep the vessel's hatches closed when fueling. Open and ventilate cabin after fueling. Check below for fumes/vapor before running the blower. Run the blower for four minutes before starting your engine.
- All fuel vapors are highly explosive. Use extreme care when handling and storing fuels. Store fuel in a well-ventilated area away from spark-producing equipment and out of the reach of children.
- Do not fill the fuel tank(s) while the engine is running.
- Shut off the fuel service valve at the engine when servicing the fuel system. Take care in catching any fuel that might spill. DO NOT allow any smoking, open flames, or other sources of fire near the fuel system or engine when servicing. Ensure proper ventilation exists when servicing the fuel system.
- Do not alter or modify the fuel system.
- Be sure all fuel supplies have a positive shutoff valve.
- Be certain fuel line fittings are adequately tightened and free of leaks.
- Make sure a fire extinguisher is installed nearby and is properly maintained. Be familiar with its proper use. Extinguishers rated ABC by the NFPA are appropriate for all applications encountered in this environment.



SAFETY INSTRUCTIONS

ACCIDENTAL STARTING

⚠ WARNING: Accidental starting can cause injury or death!

- Disconnect the battery cables before servicing the engine/generator. Remove the negative lead first and reconnect it last.
- Make certain all personnel are clear of the engine before starting.
- Make certain all covers, guards, and hatches are re-installed before starting the engine.

BATTERY EXPLOSION

⚠ WARNING: Battery explosion can cause injury or death!

- Do not smoke or allow an open flame near the battery being serviced. Lead acid batteries emit hydrogen, a highly explosive gas, which can be ignited by electrical arcing or by lit tobacco products. Shut off all electrical equipment in the vicinity to prevent electrical arcing during servicing.
- Never connect the negative (-) battery cable to the positive (+) connection terminal of the starter solenoid. Do not test the battery condition by shorting the terminals together. Sparks could ignite battery gases or fuel vapors. Ventilate any compartment containing batteries to prevent accumulation of explosive gases. To avoid sparks, do not disturb the battery charger connections while the battery is being charged.
- Avoid contacting the terminals with tools, etc., to prevent burns or sparks that could cause an explosion. Remove wristwatch, rings, and any other jewelry before handling the battery.
- Always turn the battery charger off before disconnecting the battery connections. Remove the negative lead first and reconnect it last when servicing the battery.

BATTERY ACID

⚠ WARNING: Sulfuric acid in batteries can cause severe injury or death!

- When servicing the battery or checking the electrolyte level, wear rubber gloves, a rubber apron, and eye protection. Batteries contain sulfuric acid which is destructive. If it comes in contact with your skin, wash it off at once with water. Acid may splash on the skin or into the eyes inadvertently when removing electrolyte caps.

TOXIC EXHAUST GASES

⚠ WARNING: Carbon monoxide (CO) is a deadly gas!

- Ensure that the exhaust system is adequate to expel gases discharged from the engine. Check the exhaust system regularly for leaks and make sure the exhaust manifolds are securely attached and no warping exists. Pay close attention to the manifold, water injection elbow, and exhaust pipe nipple.
- Be sure the unit and its surroundings are well ventilated.
- In addition to routine inspection of the exhaust system, install a carbon monoxide detector. Consult your boat builder or dealer for installation of approved detectors.
- For additional information refer to ABYC T-22 (educational information on Carbon Monoxide).

⚠ WARNING: Carbon monoxide (CO) is an invisible odorless gas. Inhalation produces flu-like symptoms, nausea or death!

- Do not use copper tubing in diesel exhaust systems. Diesel fumes can rapidly destroy copper tubing in exhaust systems. Exhaust sulfur causes rapid deterioration of copper tubing resulting in exhaust/water leakage.
- Do not install exhaust outlet where exhaust can be drawn through portholes, vents, or air conditioners. If the engine exhaust discharge outlet is near the waterline, water could enter the exhaust discharge outlet and close or restrict the flow of exhaust. Avoid overloading the craft.
- Although diesel engine exhaust gases are not as toxic as exhaust fumes from gasoline engines, carbon monoxide gas is present in diesel exhaust fumes. Some of the symptoms or signs of carbon monoxide inhalation or poisoning are:

Dizziness	Throbbing in Temples
Nausea	Muscular Twitching
Weakness and Sleepiness	Vomiting
Headache	Inability to Think Coherently

AVOID MOVING PARTS

⚠ WARNING: Rotating parts can cause injury or death!

- Do not service the engine while it is running. If a situation arises in which it is absolutely necessary to make operating adjustments, use extreme care to avoid touching moving parts and hot exhaust system components.



SAFETY INSTRUCTIONS

- Do not wear loose clothing or jewelry when servicing equipment; tie back long hair and avoid wearing loose jackets, shirts, sleeves, rings, necklaces or bracelets that could be caught in moving parts.
- Make sure all attaching hardware is properly tightened. Keep protective shields and guards in their respective places at all times.
- Do not check fluid levels or the drive belt's tension while the engine is operating.
- Stay clear of the drive shaft and the transmission coupling when the engine is running; hair and clothing can easily be caught in these rotating parts.

HAZARDOUS NOISE

 **WARNING: High noise levels can cause hearing loss!**

- Never operate an engine without its muffler installed.
- Do not run an engine with the air intake (silencer) removed.
- Do not run engines for long periods with their enclosures open.

 **WARNING: Do not work on machinery when you are mentally or physically incapacitated by fatigue!**

OPERATORS MANUAL

Many of the preceding safety tips and warnings are repeated in your Operators Manual along with other cautions and notes to highlight critical information. Read your manual carefully, maintain your equipment, and follow all safety procedures.

ENGINE INSTALLATIONS

Preparations to install an engine should begin with a thorough examination of the American Boat and Yacht Council's (ABYC) standards. These standards are a combination of sources including the USCG and the NFPA.

Sections of the ABYC standards of particular interest are:

- H-2 Ventilation
- P-1 Exhaust systems
- P-4 Inboard engines
- E-9 DC Electrical systems

All installations must comply with the Federal Code of Regulations (FCR).

ABYC, NFPA AND USCG PUBLICATIONS FOR INSTALLING DIESEL ENGINES

Read the following ABYC, NFPA and USCG publications for safety codes and standards. Follow their recommendations when installing your engine.

ABYC (American Boat and Yacht Council)
Safety Standards for Small Craft

Order from:

ABYC
3069 Solomons Island Rd.
Edgewater, MD 21037

NFPA (National Fire Protection Association)
Fire Protection Standard for Motor Craft

Order from:

NFPA
11 Tracy Drive
Avon Industrial Park
Avon, MA 02322

USCG (United States Coast Guard)
USCG 33CFR183

Order from:

U.S. Government Printing Office
Washington, D.C. 20404



INSTALLATION

When installing WESTERBEKE engines and generators, it is important that strict attention be paid to the following information:

CODES AND REGULATIONS

Federal regulations, ABYC guidelines and safety codes must be complied with when installing engines and generators in a marine environment.

SIPHON-BREAK

For installations where the exhaust manifold/water-injected exhaust elbow is close to or will be below the vessel's waterline, provisions **must** be made to install a siphon-break in the raw water supply hose to the exhaust elbow. This hose **must** be looped a minimum of 20 in (51 cm) above the vessel's waterline. ***Failure to use a siphon-break when the exhaust manifold injection port is at or below the load waterline will result in raw water damage to the engine and possible flooding of the boat.***

If you have any doubt about the position of the water-injected exhaust elbow relative to the vessel's waterline under any of the vessel's various operating conditions or when the vessel is not underway, **install a siphon-break**. This precaution is necessary to protect your engine.

NOTE: *A siphon-break requires periodic inspection and cleaning to ensure proper operation. Failure to properly maintain a siphon-break can result in catastrophic engine damage. Consult the siphon-break manufacturer for a proper maintenance schedule.*

EXHAUST SYSTEM

The exhaust hose must be certified for marine use. The system must be designed to prevent water from entering the exhaust under any sea conditions and at any angle of the vessel's hull.

A detailed 40 page Marine Installation Manual covering gasoline and diesel, engines and generators, is available from your WESTERBEKE dealer.



TABLE OF CONTENTS

Introduction.....	2	32 KW BEDA Generator Parts Identification.....	102
90A Four Propulsion Engine Specifications.....	4	Generator Information.....	103
90A Four Propulsion Engine Parts Identification.....	5	Generator Control Panel Switches.....	104
Testing for Overhaul.....	6	Control Panel Troubleshooting.....	105
Engine Troubleshooting.....	7	The BE Generator, Single and Three Phase.....	106
Engine Disassembly.....	14	Generator AC Voltage Connections.....	107
Engine Inspection and Repair.....	20	Voltage Regulator Adjustments.....	109
Engine Reassembly.....	31	Internal Wiring Schematics.....	110
Exhaust Manifold.....	47	BE Troubleshooting.....	112
Engine Adjustments.....	48	Electronic Governor.....	113
Lubrication System.....	51	Troubleshooting the Electronic Governor.....	114
Cooling System.....	54	Shore Power Transfer Switch.....	115
Fuel System.....	59	32 KW BEDA Generator Wiring Diagram #040425 (Single Relay).....	116
Starter Motor.....	64	32 KW BEDA Generator Wiring Schematic #040425 (Single Relay).....	117
Admiral Control Panel.....	78	32 KW BEDA Generator Wiring Diagram #040425 (Two Relays).....	118
Captain Control Panel.....	79	32 KW BEDA Generator Wiring Schematic #040425 (Two Relays).....	119
Control Panel Troubleshooting.....	80	32 KW BEDA Generator Wiring Diagram #44737 (Two Relays) (Plug-in Remote Start/Stop Panel).....	120
DC Electrical System.....	81	32 KW BEDA Generator Wiring Schematic #44737 (Two Relays) (Plug-in Remote Start/Stop Panel).....	121
Alternator.....	82	32 KW BEDA Generator Wiring Diagram #041128 (Single Relay) 24 VDC Special Spec.....	122
Dual Output Alternators.....	84	32 KW BEDA Generator Wiring Schematic #041128 (Single Relay) 24 VDC Special Spec.....	123
90A Four Propulsion Engine Wiring Diagram # 41343.....	86	32 KW BEDA Generator Wiring Diagram #44806 (Two Relays) (Plug-in Remote Start/Stop Panel).....	124
90A Four Propulsion Engine Wiring Schematic # 41343.....	87	32 KW BEDA Generator Wiring Schematic #44806 (Two Relays) (Plug-in Remote Start/Stop Panel).....	125
Hurth HSW Transmissions.....	88	Special Tools – Generator.....	126
Hurth HBW 250 Transmission.....	91	Index.....	128
Borg Warner Velvet Drive Transmission.....	93	Metric Conversions.....	130
Transmission Troubleshooting.....	96	Standard and Metric Conversion Data.....	131
Standard Hardware / Sealants & Lubricants.....	98		
90A Four Torque Specifications.....	99		
32 KW BEDA Generator Specifications.....	100		

INTRODUCTION

ENGINE OVERHAUL

This service manual contains detailed information relating to the overhaul of the 90A Four Diesel Engine and the 32.0 KW/25.0 KW BEDA Diesel Generators. For the major engine overhaul procedure, refer to the *ENGINE DISASSEMBLY, ENGINE INSPECTION AND REPAIR*, and *ENGINE REASSEMBLY* sections. Additional service information for the generators and other specific components and systems may be found by referring to the *TABLE OF CONTENTS* and the *INDEX*. Refer also to your WESTERBEKE Parts Catalog.

These service procedures are intended for the guidance of suitably equipped and staffed marine engine service and rebuilding facilities, and should only be undertaken by such facilities and their personnel.

PRODUCT SOFTWARE

Product software (tech data, parts lists, manuals, brochures and catalogs) provided from sources other than WESTERBEKE are not within WESTERBEKE'S control.

WESTERBEKE CANNOT BE RESPONSIBLE FOR THE CONTENT OF SUCH SOFTWARE, MAKES NO WARRANTIES OR REPRESENTATIONS WITH RESPECT THERETO, INCLUDING ACCURACY, TIMELINESS OR COMPLETENESS THEREOF AND WILL IN NO EVENT BE LIABLE FOR ANY TYPE OF DAMAGE OR INJURY INCURRED IN CONNECTION WITH OR ARISING OUT OF THE FURNISHING OR USE OF SUCH SOFTWARE.

WESTERBEKE customers should also keep in mind the time span between printings of WESTERBEKE product software and the unavoidable existence of earlier WESTERBEKE manuals. Product software provided with WESTERBEKE products, whether from WESTERBEKE or other suppliers, must not and cannot be relied upon exclusively as the definitive authority on the respective product. It not only makes good sense but is imperative that appropriate representatives of WESTERBEKE or the supplier in question be consulted to determine the accuracy and currentness of the product software being consulted by the customer.

NOTES, CAUTION AND WARNINGS

As this manual takes you through the service procedures and troubleshooting of your marine engine, critical information will be highlighted by *NOTES, CAUTIONS, and WARNINGS*. An explanation follows.

NOTE: *An operating procedure essential to note.*

CAUTION: *Procedures, which if not strictly observed, can result in the damage or destruction of your engine.*

WARNING: *Procedures, which if not properly followed, can result in personal injury or loss of life.*

CUSTOMER IDENTIFICATION CARD



Customer Identification

MR. ENGINE OWNER

MAIN STREET

HOMETOWN, USA

Model 90A FOUR

Ser.#U0000-D906

Expires 8/2/00

The WESTERBEKE engine serial number is an alphanumeric number that can assist in determining the date of manufacture of your WESTERBEKE engine. The manufacturer's date code is placed at the end of the engine serial number and consists of a character followed by three numbers. The character indicates the decade (A=1960s, B=1970s, C=1980s, D=1990s, E=2000s), the first number represents the year in the decade, and the second and third numbers represent the month of manufacture.

ORDERING PARTS/SERIAL NUMBER LOCATION

Whenever replacement parts are needed, always provide the engine model number and engine serial number as they appear on the silver and black identification nameplate located on the side of the engine's exhaust manifold. The engine serial number can also be found stamped into the engine block just above the injection pump, and on generators, on the decal located on the side of the generator. You must provide us with this information so we may properly identify your engine. In addition, include a complete part description and part number for each part needed (see the separately furnished Parts List). Also insist upon WESTERBEKE packaged parts because *will fit* or generic parts are frequently not made to the same specifications as original equipment.

NOTE: *Component locations in this manual are referenced from the front of the engine which is the pulley/drive belt end. Left and right sides are determined as follows: imagine straddling the engine, facing in the same direction as the front of the engine: the left side is at your left, the right side is at your right.*



INTRODUCTION

Owners may find it convenient to fill in the data on the decal or identification nameplate shown below to provide a quick reference when using this service manual.

SPECIFICATION	50 HZ.	60 HZ.
MODEL		
RPM		
KW		
KVA		
VOLTS		
AMPS		
ENG. HP		
ENG. SER. NO.		
GEN. SER. NO.		
PF/PHASE	/	
WIRES		
RATING		
INSUL. CLASS		
TEMP. RISE		
BATTERY		
C.I.D.		

GENERATOR DECAL



ENGINE IDENTIFICATION NAMEPLATE



90A FOUR PROPULSION ENGINE SPECIFICATIONS

SPECIFICATIONS

Engine Type	Diesel, four-cycle, four-cylinder, fresh water-cooled, vertical in-line overhead valve mechanism, (90 hp at 3600 rpm maximum).
Aspiration	Naturally aspirated.
Governor	Integral with the injection pump; mechanical flyweight type.
Bore & Stroke	3.94 x 4.33 inches (100.0 x 110.0 mm)
Piston Displacement	210.8 cubic inches (3.5 liters)
Firing Order	1 - 3 - 4 - 2
Direction of Rotation	Clockwise, when viewed from the front.
Maximum Torque (at 3600 rpm)	168 lb-ft (23 kg-m)
Compression Ratio	18:1
Dimensions	Height: 36.0 inches (91.4 cm) Width: 23.0 inches (58.4 cm) Length: 39.3 inches (99.8 cm)
Weight	790 lbs (358.3 kgs)

TUNE-UP SPECIFICATIONS

Compression Pressure (Limit of difference between cylinders)	427 psi (30 kg/cm ²) at 200 rpm 47.6 psi (3.0 kg/cm ²)
Valve Timing	Intake Opens 19° BTDC Intake Closes 47° ABDC Exhaust Opens 52° BBDC Exhaust Closes 14° ATDC
Engine Timing	Static timed - drop valve method 0.180 ± 0.005 inches BTDC.
Injector Pressure	2450 ± 35 psi (172.2 ± 2.5 kg/cm ²).
Valve Seat Angle	Intake 45° Exhaust 30°
Valve Clearance (engine cold)	Intake 0.012 inches (0.3 mm) Exhaust 0.014 inches (0.35 mm)
Engine Speed	Idle: 700 - 900 rpm Cruise: 2500 - 3000 rpm Max: 3500 - 3600 rpm

COOLING SYSTEM

General	Fresh water-cooled block, thermostatically-controlled with heat exchanger.
Operating Temperature	170 - 190° F (77 - 88° C)
Coolant Pump	Centrifugal type, metal impeller, belt-driven.
Raw Water Pump	Positive displacement, rubber impeller, belt-driven.
Raw Water Flow, at 3600 rpm	20.0 US gpm (75.5 lpm) (measured before discharging into exhaust elbow).
Coolant (fresh water) System Capacity	8.5 US qts (8.04 liters)

EXHAUST SYSTEM

Exhaust Elbow	70° elbow
Exhaust Hose Size	3" I.D. hose

FUEL SYSTEM

General	Closed system with bleed points.
Fuel	No. 2 diesel oil (cetane rating of 45 or higher).
Fuel Injection Pump	ZEXEL Model PE (In-Line).
Fuel Injection Timing	12° BTDC
Nozzle	Orifice type.
Fuel filter (on engine)	Full flow replaceable, spin-on element.
Air Intake Silencer	Metal screen type - cleanable. Tuned intake (no filter).
Air Flow (engine combustion)	220 cfm (6.2 cmm)
Fuel consumption	2.0 U.S. gph (7.5 lph) at 2500 rpm

LUBRICATION SYSTEM

General	Pressure fed system.
Oil pump	Trochoid type.
Oil filter	Full flow, paper element, spin-on type.
Oil cooler	Water cooled.
Sump Capacity (not including filter)	6.3 U.S. qts (6.0 liters) plus filter/cooler assembly.
Operating Oil Pressure (engine hot)	50 - 55 psi (3.5 - 3.9 kg/cm ²)
Oil Grade	API Specification CF or CG-4, SAE 30, 10W-30, 15W-40

ELECTRICAL SYSTEM

Starting Battery	12 Volt, (-) negative ground
Battery Capacity	800 - 900 Cold Cranking Amps (CCA)
DC Charging Alternator	51 amp rated, belt-driven
Starting Aid	Air intake heater
Starter	12 Volt, 3 KW
DC No-Load Current	± 2% of rated amps
DC Cranking Current	250 - 300 amps (engine cold)

ENGINE AIR REQUIREMENTS

Combustion Air	220 cfm (6.2 cmm)
Engine Cooling	100 cfm (2.8 cmm)

Note: The pressure differential between the outside of the engine compartment versus the inside of the engine compartment should not exceed 2 inches of water (51 mm) at full open throttle (measured with a manometer).

TRANSMISSION

General	(Hurth Standard Transmission) Case-hardened helical gears, with a servo-operated multiple disc clutch.
Gear ratio (standard)	2.74 : 1 (HBW250 - 3R)
Propeller Shaft	Right handed - standard transmission
Propeller Recommendations (using standard transmission 2.74 : 1 reduction)	24 D x 12 P-2 blade or 22 D x 14 P-3 blade propeller should allow the engine to reach its full rated rpm (3600 + 000 - 100) at full open throttle while under way in forward gear.
Lubricating Fluid	ATF - type A or Dextron - II or III
Transmission Sump Capacity	0.79 U.S. qts (0.75 liters) approximate



90A FOUR PROPULSION ENGINE PARTS IDENTIFICATION

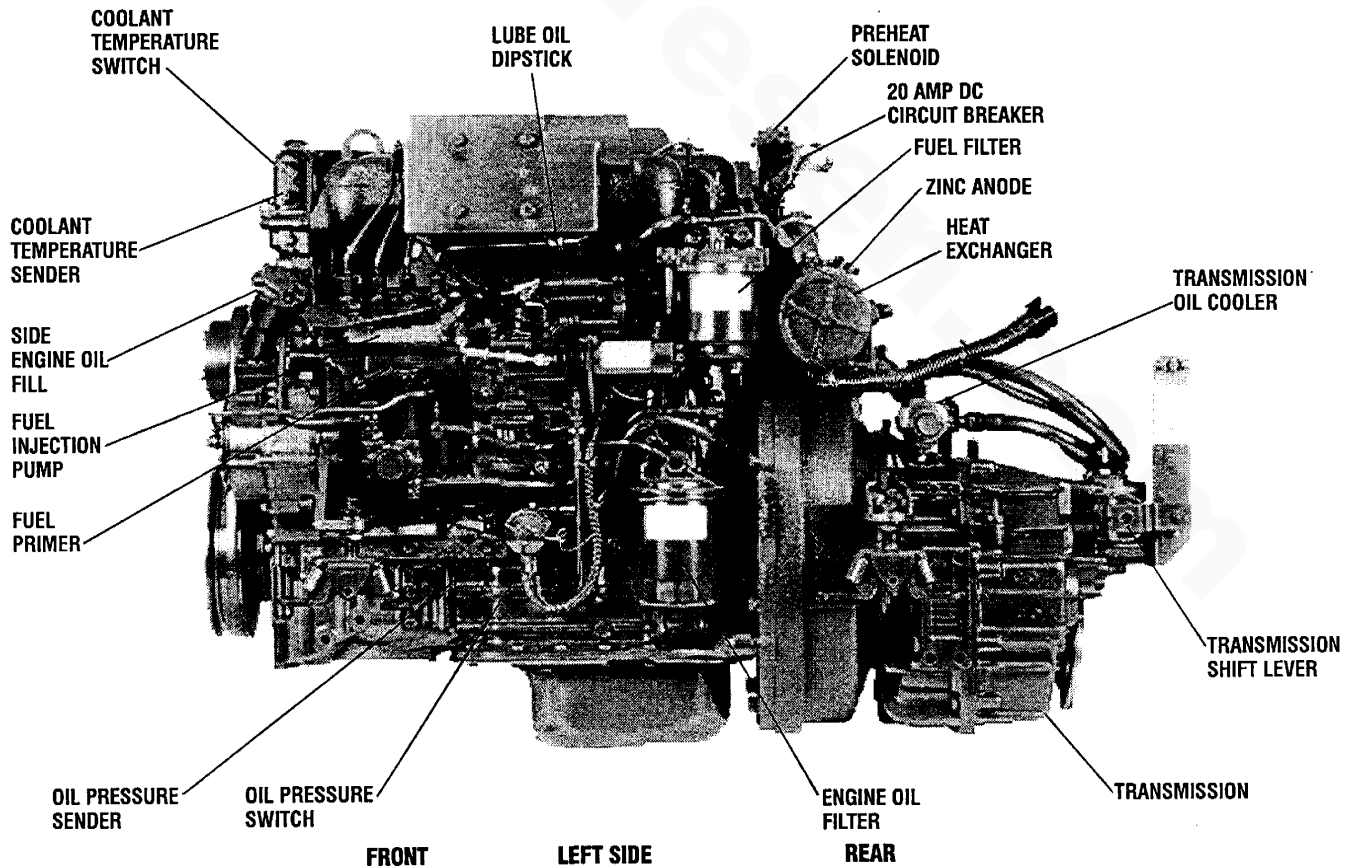
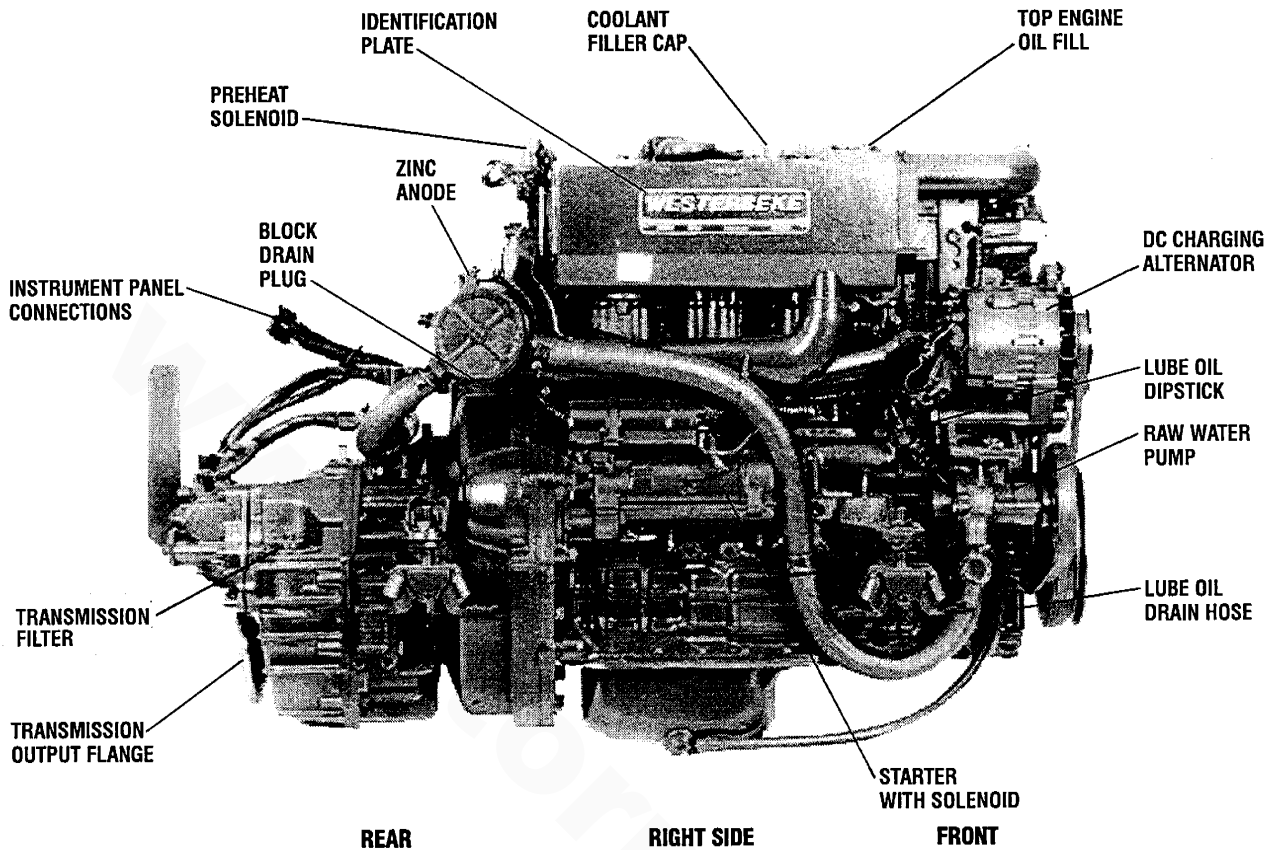

TESTING FOR OVERHAUL

HOW TO DETERMINE WHEN TO OVERHAUL THE ENGINE

Cause of Low Compression

Generally, the time at which an engine should be overhauled is determined by various conditions such as lowered engine power output, decreased compression pressure, and increased fuel and oil consumption. The lowered engine power output, in the case of diesel engines, is not necessarily due to trouble with the engine itself, but is sometimes caused by injector nozzle wear or injection pump wear. It is most reasonable to judge by a decrease in compression pressure. The decrease in compression pressure is caused by many factors. It is, therefore, necessary to determine a cause or causes on the basis of data produced by periodic inspection and maintenance. Oil analysis on a seasonal basis is a good means of monitoring engine internal wear. When caused by worn cylinders or piston rings, the following symptoms will occur:

- Low engine power output
- Increased fuel consumption
- Increased oil consumption
- Hard engine starting
- Noisy engine operation

These symptoms often appear together. Increased fuel consumption and hard engine starting can also result from excessive fuel injection, improper injection timing, and wear of the injection pump and nozzles. They are also caused by defective electrical components such as the battery, alternator, starter and air intake heater. Therefore it is desirable to judge the optimum engine overhaul time by the lowered compression pressure caused by worn cylinders and pistons plus increased oil consumption. In diesel engines, satisfactory combustion is obtained only under sufficient compression pressure. If an engine lacks compression pressure, incomplete combustion of fuel will take place even if other parts of the engine are operating properly. To determine the period of engine overhaul, it is important to measure the engine compression pressure regularly. At the same time, the engine speed at which the measurement of compression pressure is made should be checked because the compression pressure varies with engine rpm. The engine rpm can be measured at the front end of the crankshaft.

Measuring Compression Pressure

To check the compression pressure, see *ENGINE COMPRESSION TEST* under *ENGINE ADJUSTMENTS*.

NOTE: Do not guess the conditions of other cylinders from a result of testing one cylinder. Be sure to measure the compression pressure for each cylinder. Look for cylinders with dramatically (at least 20%) lower compression than the average of the other cylinders. If the weak cylinder is flanked by healthy cylinders, the problem is either valve- or head-gasket related. Very low compression in an adjacent cylinder indicates gasket failure. Abnormally high readings on all cylinders indicate heavy carbon accumulations, a condition that might be accompanied by high pressures and noise.

NOTE: In case of severe vibrations and detonation noise, have the injectors overhauled by an authorized fuel injection service center. Poor fuel quality, contaminants, and loss of positive fuel pressure to the injection pump will result in injector faults.

OVERHAUL CONDITIONS

Compression pressure tends to increase a little in a new engine until the piston rings and valve seats have been broken in. Thereafter, it decreases gradually with the progressive wear of these parts.

When the decrease of compression pressure reaches its limit (see *SERVICE STANDARDS*), the engine must be overhauled. The engine also requires an overhaul when oil consumption is high, when blowby is evident, and when compression values are at a minimum or below.

NOTE: Refer to the *SERVICE STANDARDS* chart during an engine overhaul. It gives the measurements and values for the repair or replacement of the engine components.

NOTE: The *ENGINE TROUBLESHOOTING* section may be helpful in determining the need for an engine overhaul.

ENGINE TROUBLESHOOTING

The following troubleshooting table describes certain problems relating to engine service, the probable causes of these problems, and the recommendations to overcome these problems.

NOTE: *The engine's electrical system is protected by a 20 ampere manual reset circuit breaker located on a bracket. The preheat solenoid is mounted on the same bracket.*

PROBLEM	PROBABLE CAUSE	VERIFICATION/REMEDY
HARD STARTING	LOW CRANKING SPEED 1. Engine oil viscosity too high. 2. Run-down battery. 3. Worn battery. 4. Battery terminals loosely connected. 5. Defective starter.	1. Replace engine oil with less viscous oil. 2. Recharge battery. 3. Replace battery. 4. Clean terminals and tighten cables. 5. Repair or replace starter.
	DEFECTIVE FUEL INJECTION SYSTEM 1. No fuel at injectors. a. No fuel in fuel tank and/or fuel shutoff. b. Fuel filter/water separator clogged. c. Injection pump fuel filter clogged. d. Fuel shutoff solenoid not working. e. Injection pump faulty. 2. Fuel injectors faulty; inadequate spray. 3. Low injection pressure. 4. Injection timing incorrect. 5. Poor quality fuel. 6. Water and/or air in fuel system.	1. Check a. through e. a. Fill fuel tank. Open shutoff and bleed system. b. Replace filter and bleed. c. Bleed injection pump. Check fittings for suction leak on fuel supply. d. Check solenoid. e. Inspect pump. Repair or replace pump as needed. 2. Remove and test nozzles. Repair nozzles as needed. 3. Adjust injection pressure. 4. Check and adjust timing. 5. Drain and replace with proper fuel. 6. Remove water and/or bleed air from fuel system. Check fuel system for leaks and fuel tank for water contamination.
	MAIN ENGINE TROUBLES 1. Low compression. a. Leaking compression from fuel injector gasket. b. Incorrect valve clearance. c. Inadequate contact of valve seat. d. Valve stem seized. e. Weak or broken valve spring. f. Bent push rod. g. Compression leaks through cylinder head gasket. h. Cracked or worn piston. i. Piston ring seized. j. Worn piston ring or cylinder liner. k. Cracked or distorted cylinder head. 2. Carbon accumulation in combustion chamber. 3. Faulty air intake heater.	1. Check a. through k. a. Tighten fuel injector or replace gasket. b. Adjust valve clearance. c. Lap valve. d. Replace valve and valve guide. e. Replace valve spring. f. Replace push rod. g. Replace gasket. h. Replace piston. i. Replace piston and piston ring. j. Replace piston ring or cylinder liner. k. Replace cylinder head. 2. Clean. 3. Check terminal connections; replace heater.

(continued)



ENGINE TROUBLESHOOTING

PROBLEM	PROBABLE CAUSE	VERIFICATION/REMEDY
ENGINE IDLING TOO LOW	<ol style="list-style-type: none"> 1. Idle speed too low. 2. Fuel filter clogged. 3. Incorrect injection pump timing. 4. High pressure injection line leaking. 5. Fuel injector leaking at sealing gasket in head. 6. Injection nozzle not operating properly. 7. Engine air intake obstructed. 	<ol style="list-style-type: none"> 1. Adjust idle stop as needed. 2. Replace filter and bleed fuel system. 3. Check timing and adjust as needed. 4. Slacken attaching nut and retighten. 5. Retighten injector and/or replace sealing washer. 6. Check nozzle and adjust as needed. 7. Check air intake silencer and air flow into engine compartment.
ROUGH IDLING	MALFUNCTION OF ENGINE-RELATED COMPONENTS	<ol style="list-style-type: none"> 1. Adjust clearance. 2. Repair or replace valve. 3. Replace gasket.
	FUEL INJECTION SYSTEM PROBLEM	<ol style="list-style-type: none"> 1. Adjust idling speed. 2. Adjust injection timing. 3. Clean fuel line or replace fuel filter. 4. Repair fuel line or replace fuel filter. 5. Bleed air. 6. Clean or replace delivery valve. 7. Adjust starting pressure. 8. Clean or replace injection nozzle. 9. Clean or replace feed pump. 10. Replace timer. 11. Take to a fuel injection pump service facility, or replace the pump.
ENGINE SLOWS AND STOPS	<ol style="list-style-type: none"> 1. Fuel lift pump failure. 2. Switches and/or wiring loose or disconnected. 3. Fuel starvation. 4. 20 amp circuit breaker tripping. 5. Exhaust system is restricted. 6. Water in fuel. 	<ol style="list-style-type: none"> 1. Check fuel pump operation. 2. Inspect wiring for short circuits and loose connections. Inspect switches for proper operation. 3. Check fuel supply, fuel valves, fuel lift pump. 4. Check for high DC amperage draw during operation. Ensure breaker is not overly sensitive to heat which would cause tripping. 5. Check for blockage, collapsed hose, carbon buildup at exhaust elbow. 6. Pump water from fuel tank(s); change filters and bleed fuel system.

(continued)



ENGINE TROUBLESHOOTING

PROBLEM	PROBABLE CAUSE	VERIFICATION/REMEDY
LOW OUTPUT	LOW COMPRESSION	See <i>Low Compression</i> under <i>HARD STARTING</i> .
	INJECTION SYSTEM OUT OF ADJUSTMENT 1. Incorrect injection timing. 2. Insufficient injection. 3. Low injection pressure.	1. Adjust injection timing. 2. Repair or replace injection pump. 3. Check injection nozzle and adjust pressure.
	INSUFFICIENT FUEL 1. Air trapped in fuel system. 2. Clogged filter. 3. Contaminated or inferior fuel. 4. Contaminated fuel tank.	1. Bleed and check for source. 2. Clean or replace filter element. 3. Purge fuel system and replace with quality fuel. 4. Clean fuel tank.
	OVERHEATING 1. Low coolant level. 2. Loose V-belt. 3. Incorrect injection timing. 4. Low engine oil level.	1. Add coolant. 2. Adjust or replace V-belt. 3. Adjust injection timing. 4. Add engine oil.
	OTHER 1. Insufficient intake air.	1. Increase engine compartment air supply.
KNOCKING	ENGINE KNOCKS WITHOUT MUCH SMOKE 1. Main engine troubles. a. Overheated cylinder. b. Carbon deposits in cylinder. 2. Injection timing too early. 3. Injection pressure too high. 4. Improper fuel.	1. Check a. and b. a. See <i>ENGINE OVERHEATS/SHUTS DOWN; LOW OUTPUT</i> . b. Clean. 2. Correct the timing. 3. Correct the pressure. 4. Replace with proper fuel.
	KNOCKING WITH DARK SMOKE 1. Poor compression. 2. Injection pump malfunctioning. 3. Nozzle malfunctioning. a. Poor spray. b. Chattering. c. After-injection drip. d. Nozzle needle valve seized.	1. See <i>Low Compression</i> under <i>HARD STARTING</i> . 2. Adjust/Repair. 3. Check a. through d. a. Clean or replace nozzle. b. Repair or replace nozzle. c. Repair or replace nozzle. d. Replace needle valve.
ABNORMAL SOUND OR NOISE	CRANKSHAFT AND MAIN BEARING 1. Badly worn main bearing. 2. Badly worn crankshaft. 3. Melted bearing. 4. Excessive crankshaft end play.	1. Replace bearing and grind crankshaft. 2. Grind crankshaft. 3. Replace bearing and check lubrication system. 4. Repair or replace crankshaft.

ENGINE TROUBLESHOOTING

PROBLEM	PROBABLE CAUSE	VERIFICATION/REMEDY
ABNORMAL SOUND OR NOISE (Cont'd)	CONNECTING ROD AND CONNECTING ROD BEARING 1. Worn connecting rod big end bearing. 2. Worn crankpin. 3. Bent connecting rod. 4. Excessive connecting rod bearing oil clearance. 5. Connecting rod bearing seized or heat-damaged.	1. Replace bearing. 2. Grind crankshaft. 3. Correct bend or replace. 4. Repair or replace bearing. 5. Replace bearing.
	PISTON, PISTON PIN, PISTON RING, CYLINDER LINER 1. Worn cylinder liner. 2. Worn piston or piston pin. 3. Piston seized. 4. Piston seized and ring worn or damaged.	1. Repair or replace liner. 2. Replace piston. 3. Replace piston and rebore cylinder. 4. Replace piston and rings.
	VALVES OR TIMING-RELATED PARTS 1. Worn camshaft. 2. Excessive valve clearance. 3. Worn timing gear. 4. Broken valve spring. 5. Excessive clearance between rocker arm and bushing. 6. Excessive clearance between idler gear bushing and spindle.	1. Replace camshaft. 2. Adjust valve clearance. 3. Replace timing gear. 4. Replace valve spring. 5. Replace bushing. 6. Replace bushing.
	FUEL SYSTEM 1. Poor quality and/or incorrect fuel. 2. Incorrect injection timing. Timing too advanced. 3. Fuel injector stuck open.	1. Use No. 2 diesel fuel. 2. Check and correct injection timing. 3. Locate and remove faulty injector. Rebuild or replace.
	OTHER 1. Coolant pump bearing worn or seized. 2. Improper drive-belt tension. 3. Malfunction of alternator bearing. 4. Exhaust gas leakage.	1. See <i>Coolant Pump</i> under <i>COOLING SYSTEM</i> . 2. Adjust. 3. See <i>Alternator Troubleshooting</i> under <i>DC ELECTRICAL SYSTEM</i> . 4. Repair.
ROUGH OPERATION (HUNTING)	INJECTION PUMP 1. Uneven injection. 2. Inadequate injection nozzle spray.	1. Adjust injection or replace parts. 2. Replace injection nozzle.
	GOVERNING SYSTEM 1. Governor lever malfunctioning. 2. Fatigued governor spring.	1. Check governor shaft and adjust. 2. Replace spring.

(continued)



ENGINE TROUBLESHOOTING

PROBLEM	PROBABLE CAUSE	VERIFICATION/REMEDY
SMOKY EXHAUST	WHITISH OR PURPLISH 1. Engine is running cold. 2. Excessive engine oil. 3. Excessive rise of oil into combustion chamber. a. Poor piston contact. b. Seized piston ring. c. Excessive piston-to-cylinder clearance. d. Worn valve stem and valve guide. e. Low engine oil viscosity. f. Excessive oil pressure. 4. Injection timing is too late. 5. Insufficient compression.	1. Warm-up engine. 2. Correct oil level. 3. Check a. through f. a. Check. b. Clean or replace. c. Correct or replace. d. Replace valve stem and guide. e. Replace engine oil. f. Inspect the lubrication system. See <i>LUBRICATION SYSTEM</i> . 4. Adjust timing. 5. See <i>Low Compression</i> under <i>HARD STARTING</i> .
	BLUE 1. Incorrect grade of engine oil. 2. Crankcase is overfilled with engine oil (oil is blowing out through the exhaust).	1. Use the correct grade of oil; see <i>LUBRICATION SYSTEM</i> under <i>90A FOUR ENGINE SPECIFICATIONS</i> . 2. Decrease oil level.
	BLACKISH OR DARK GRAYISH 1. Poor compression. 2. Improper valve clearance. 3. Improper injection timing. 4. Improper fuel. 5. High back-pressure in exhaust. 6. Insufficient intake air. 7. Overload.	1. See <i>Low Compression</i> under <i>HARD STARTING</i> . 2. Adjust valve clearance. 3. Adjust injection timing. 4. Replace with proper fuel. 5. Check for restrictions in exhaust system. 6. Increase engine compartment air supply. 7. Reduce load.
	BLACK, LARGE AMOUNT 1. Clogged fuel filter. 2. Restricted air intake. 3. Engine overloaded. 4. Injection timing. 5. Fuel injectors not operating properly.	1. Replace fuel filter and bleed system. 2. Remove air obstruction. 3. Check engine propeller size and engine performance no-load through fully loaded. 4. Check the injection pump timing and adjust as needed. 5. Check nozzle spray pressure setting.
EXCESSIVE EXHAUST SMOKE	1. Faulty injection timing. 2. Water in injection pump, fuel filter or fuel filter/water separator. 3. Faulty injection starting pressure. 4. Injection pump malfunctioning.	1. Adjust timing. 2. Drain fuel system. 3. Adjust starting pressure. 4. Replace injection pump.

(continued)



ENGINE TROUBLESHOOTING

PROBLEM	PROBABLE CAUSE	VERIFICATION/REMEDY
INTERMITTENT EXHAUST SOUND	<ol style="list-style-type: none"> 1. Fuel filter clogged. 2. Fuel line sucks air. 3. Water mixed in fuel. 	<ol style="list-style-type: none"> 1. Clean or replace filter. 2. Retighten fuel line joints or replace fuel line. 3. Replace fuel.
EXCESSIVE FUEL CONSUMPTION	ENGINE PROBLEMS <ol style="list-style-type: none"> 1. Noisy knocking. 2. Smoky exhaust. 3. Moving parts nearly seized or excessively worn. 4. Poor compression. 5. Improper valve timing. 6. Improper valve clearance. 	<ol style="list-style-type: none"> 1. See <i>KNOCKING</i>. 2. See <i>SMOKY EXHAUST</i>. 3. Repair or replace. 4. See <i>Low Compression</i> under <i>HARD STARTING</i>. 5. Adjust timing. 6. Adjust clearance.
	INSUFFICIENT INTAKE AIR <ol style="list-style-type: none"> 1. Air intake obstructed. 	<ol style="list-style-type: none"> 1. Remove obstruction.
	FUEL INJECTION PROBLEMS <ol style="list-style-type: none"> 1. Injection timing incorrect. 2. Faulty injection starting pressure. 3. Seized nozzle. 4. Worn nozzle. 5. Nozzle leaking. 6. Injector not operating properly. 7. Clogged fuel filter. 8. High idling speed. 	<ol style="list-style-type: none"> 1. Adjust timing. 2. Adjust starting pressure. 3. Replace nozzle. 4. Replace nozzle. 5. Tighten nozzle or replace sealing gasket. 6. Adjust nozzle spray pressure. 7. Replace filter. 8. Adjust idling speed.
	FUEL PROBLEMS <ol style="list-style-type: none"> 1. Improper fuel. 2. Fuel leaks. 	<ol style="list-style-type: none"> 1. Replace with proper fuel. 2. Find fuel leaks.
	ENGINE OVERLOADED <ol style="list-style-type: none"> 1. Propeller size. 	<ol style="list-style-type: none"> 1. Check propeller size and engine performance at rated rpm.
EXCESSIVE OIL CONSUMPTION	OIL LEAKAGE <ol style="list-style-type: none"> 1. Defective oil seals. 2. Broken gear case gasket. 3. Loose gear case attaching bolts. 4. Loose drain plug. 5. Loose oil line connector. 6. Broken rocker cover gasket. 7. Loose rocker cover attaching bolts. 	<ol style="list-style-type: none"> 1. Replace oil seals. 2. Replace gasket. 3. Retighten bolts. 4. Retighten plug. 5. Retighten oil line connections. 6. Replace gasket. 7. Retighten attaching bolts.

(continued)



ENGINE TROUBLESHOOTING

PROBLEM	PROBABLE CAUSE	VERIFICATION/REMEDY
EXCESSIVE OIL CONSUMPTION (cont'd)	OIL LEVEL RISING 1. Incorrectly positioned piston ring gaps. 2. Displaced or twisted connecting rod. 3. Worn piston ring, or piston ring groove. 4. Worn piston or cylinder liner.	1. Correct ring gap positions. 2. Replace connecting rod. 3. Replace ring or piston. 4. Repair or replace.
	OIL LEVEL FALLING 1. Defective stem seal. 2. Worn valve and valve guide.	1. Replace stem seal. 2. Replace valve and valve guide.
LOW OIL PRESSURE	1. Worn main or connecting rod bearings. 2. Relief valve malfunction. 3. Clogged oil cooler. 4. Diesel fuel is diluting the oil.	1. Replace bearings. 2. Overhaul oil pump. 3. Clean. 4. Injection pump repair.
ENGINE OVERHEATS/ SHUTS DOWN	1. V-belt slackening or slippery with oil. 2. Low oil level or poor oil quality. 3. Knocking. 4. Moving parts seized or damaged. 5. Lack of coolant. 6. Raw water not circulating. 7. Coolant not circulating.	1. Adjust, replace or clean belt. 2. Add or change oil. 3. See <i>KNOCKING</i> . 4. Replace. 5. Add coolant. 6. Check a. and b. a. Raw water pump failure. Check impeller; replace if necessary. b. Obstruction at raw water intake or raw water filter. 7. Check a. through d. a. Thermostat — remove and test in hot water. Replace thermostat. b. Loss of coolant — check hoses, hose clamps, drain plug, etc. for leaks. c. Broken or loose belts — tighten/replace. d. Air leak in system; run engine and open the pressure cap to bleed air. Add coolant as needed.



ENGINE DISASSEMBLY

GENERAL DISASSEMBLY PROCEDURE

NOTE: Before disassembly and cleaning, carefully check for defects which cannot be found after disassembly and cleaning.

- All disassembled parts should be carefully arranged in the order of reassembly. Mark or label the parts as needed to insure proper mating and reassembly in the proper directions and positions.
- If the disassembly procedure is complex requiring many parts to be disassembled, the parts should be disassembled in a way that will allow them to be efficiently reassembled without any change in the engine's external appearance or its performance.
- Do not remove or disassemble parts that require no disassembly.
- Carefully inspect each part after removal for damage, deformation, and other problems.
- Carefully check gaskets, packings and oil seals, even if checking is not specified. Replace with new ones, if defective.
- Be careful not to damage the disassembled parts. Keep the parts clean.
- Use the proper tools. Apply oil when necessary. Take special care to keep the fuel system parts free from the intrusion of dust and dirt.

TRANSMISSION REMOVAL

1. Unplug the instrument panel wiring harness.
2. Drain the transmission fluid and the transmission oil cooler hoses.
3. Detach the oil cooler hoses.
4. Unbolt the transmission from the engine.

NOTE: For transmission service and maintenance, refer to your transmission owner's manual. To rebuild a transmission, contact your WESTERBEKE dealer or a qualified marine transmission service facility.

If the transmission is not being rebuilt, it should be visually inspected. Flush out and pressure-test the oil cooler, and replace the coolant hoses. Inspect and lubricate the gear shift linkage and the propeller shaft coupling. Clean and repaint the transmission and change the transmission fluid. Refer to the TRANSMISSIONS section in this manual.

GENERATOR REMOVAL

1. Disconnect the AC wiring and unplug the engine's DC wiring harness at the generator control panel.
2. Disconnect the battery cable connections and the engine ground cables.
3. Separate the exhaust hose at the water injected elbow.
4. Disconnect the fuel supply and return lines.

NOTE: Label any lines, hoses or cables as you separate them.

5. Drain the engine oil and the coolant from the engine.
6. Carefully support and then unbolt the generator back end from the engine. See *SPECIAL TOOLS-GENERATOR* in this manual.

For generator maintenance and service, refer to the *GENERATOR* section of this manual.

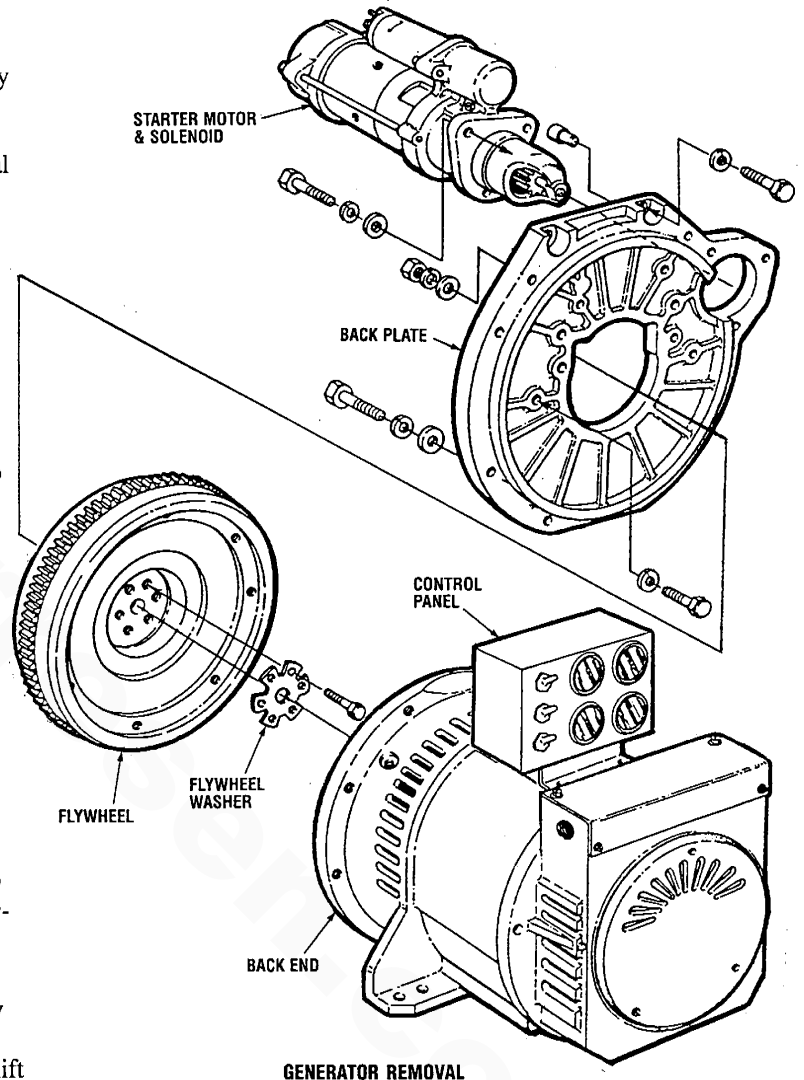

ENGINE DISASSEMBLY

With the transmission or generator separated from the engine, begin the following step-by-step procedure of the engine disassembly.

1. Clean the exterior of the engine of any deposits of dirt and oil.
2. Mount the engine on a suitable engine stand for disassembly.



ENGINE DISASSEMBLY

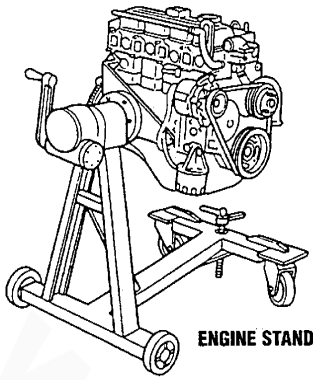

3. Drain the coolant from the engine and engine hoses, and from the heat exchanger. Drain the fuel, and drain or pump out the engine oil.
4. Remove the engine wiring harness in its entirety. Label the terminal connections to insure proper reattachment.

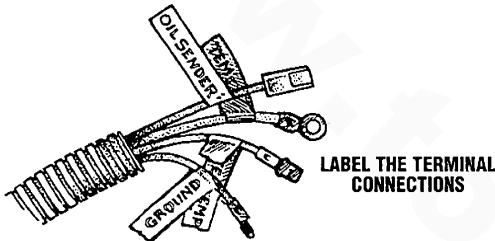

5. Remove the engine heat exchanger and the engine oil cooler/oil filter assembly. If possible, leave one end of each hose connection attached to the part being removed.
6. Remove the starter motor.
7. Remove the engine bellhousing (propulsion engines only).

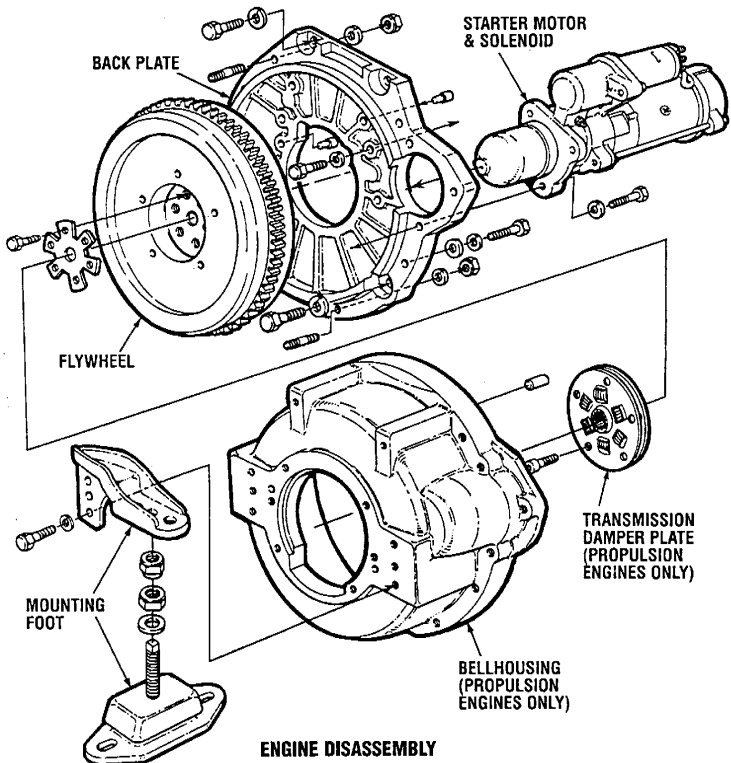

8. Remove the transmission damper plate (propulsion engines only).

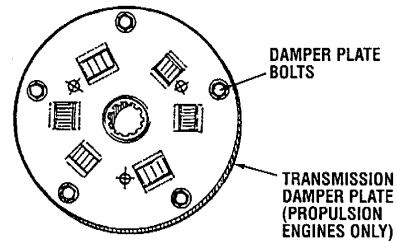

9. Remove the flywheel and flywheel washer.

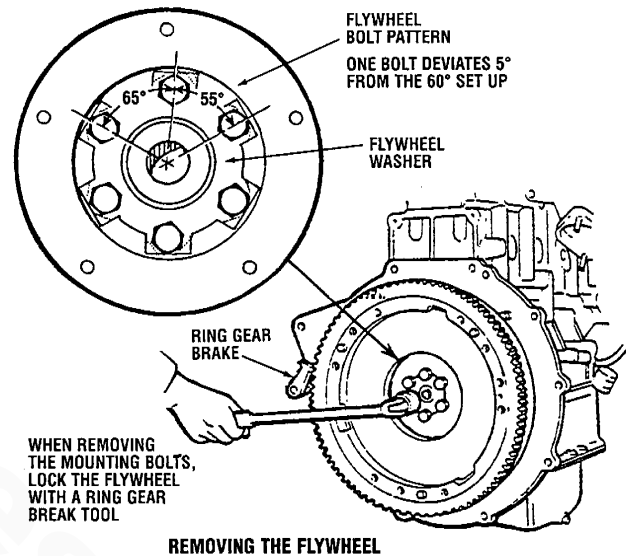

10. Remove the engine back plate.
11. Remove the exhaust manifold.
12. Remove the alternator and alternator adjusting strap.
13. Remove the raw water pump.
14. Remove all the high pressure injector lines from the injection pump to the injectors. Leave the upper line clamps in place.
NOTE: Cap the ends of the lines, and the connections at the injection pump and at the injectors, to prevent entry of foreign material.
15. Remove the oil level dipstick.
16. Remove the injection pump oil line.
17. Remove the fuel line to the injection pump. (Note the arrangement of the sealing washers on the banjo bolts at the fuel filter and the injection pump.)
18. Remove the fuel return lines from the top of the injectors and from the fuel injection pump. (Note the washer arrangement on the fuel return line banjo bolts. Cap all openings on the fuel return line, injectors and injection pump.)
19. Remove the engine-mounted fuel filter and fuel filter bracket.



ENGINE DISASSEMBLY

20. Remove the thermostat housing, gasket, and the thermostat. Leave the temperature sending unit in place.

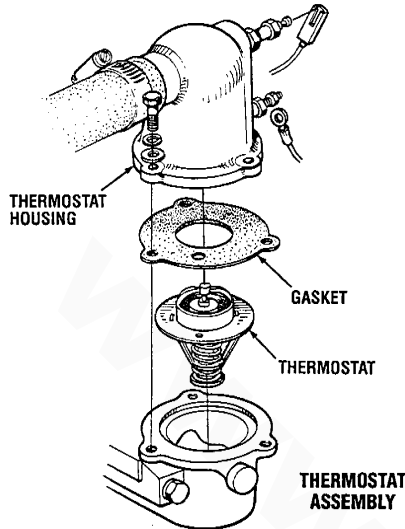

21. Remove the air intake silencer.
 22. Remove the two front lifting eyes and the rear lifting eye.
 23. Remove the intake manifold.
 24. Remove the alternator bracket.
 25. Remove the crankcase breather hose.
 26. Remove the rocker covers and gaskets.
 27. Remove the fuel injectors, O-rings and gaskets from the cylinder head.

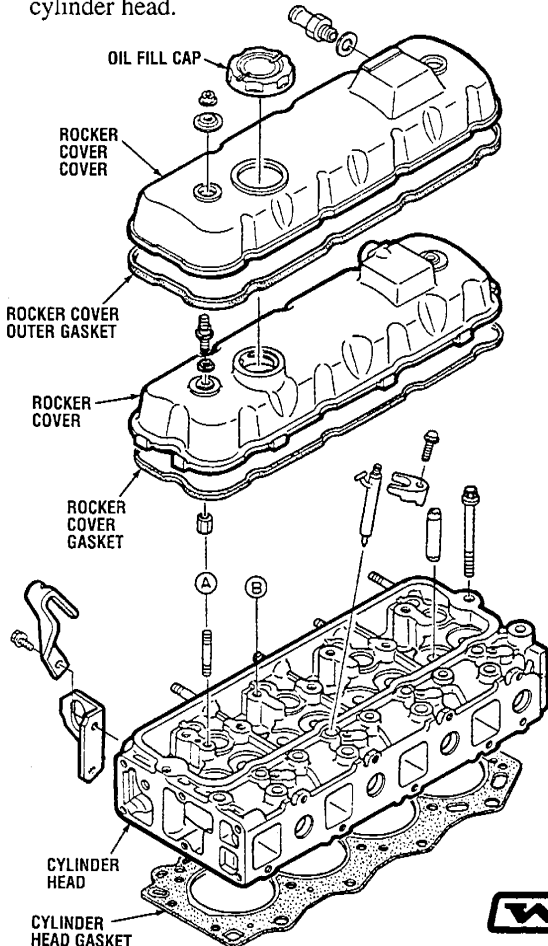

28. Loosen the cylinder head bolts gradually in the numbered sequence shown in the illustration.

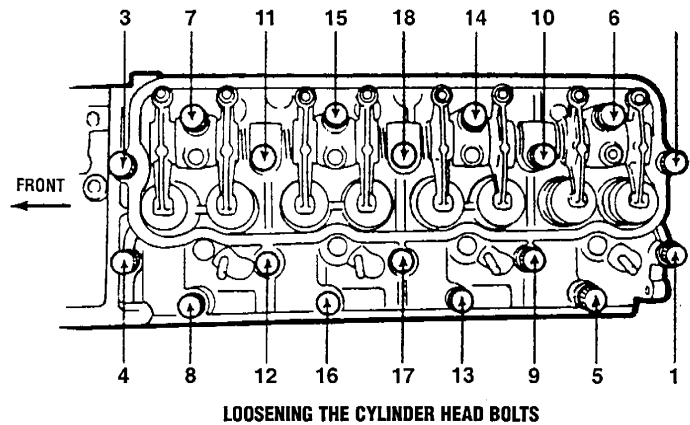

29. Remove the rocker arm and shaft assembly.
 30. Remove the push rods. Label each rod as to which valve it belongs.

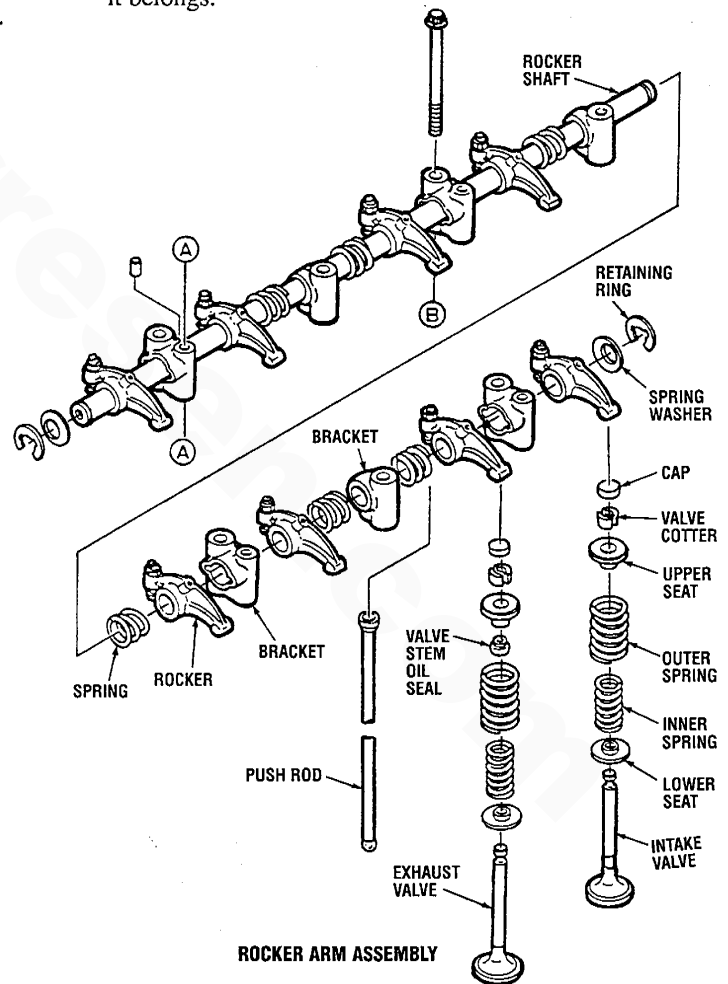

31. Remove the cylinder head by tapping it from below with a plastic hammer.
 32. Remove the cylinder head gasket.



ENGINE DISASSEMBLY

33. Valves Disassembly

- a. Mark the valves with their cylinder numbers, then remove the valves, stem caps, cotters, spring seats and springs from the cylinder head using the **valve spring lifter** (Mazda #49 0636 100A) and **pivot** (Mazda #49 0107 222A) or an appropriate valve spring compression tool.

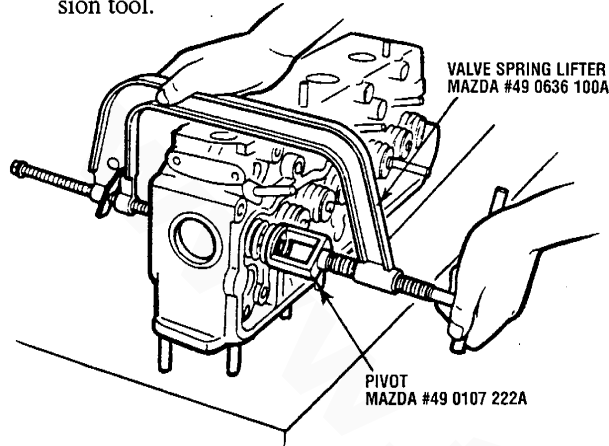

NOTE: Valve guides are only to be removed, if necessary, after completing the procedure described under Valves and Valve Guides in the ENGINE INSPECTION AND REPAIR section.

- b. Remove the valve oil seals (intake only) by grasping them with pliers and working them out.

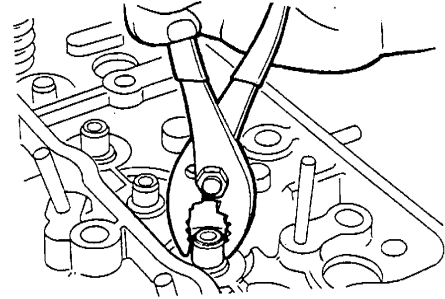

- c. When removing the valves, make sure each valve is marked so it can be returned to its original position, if reused.

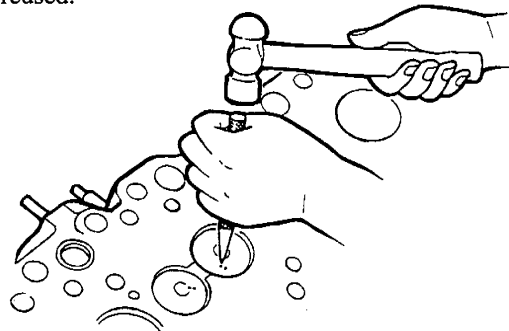

34. Timing Mechanism Disassembly

Remove the following components that are related to the timing mechanism:

- Coolant pump
 - Crankshaft pulley
 - Timing gear cover and gasket
 - Fuel injection pump
- NOTE:** See Fuel Injection Pump Removal under FUEL SYSTEM for detailed instructions on removing the fuel injection pump.
- Camshaft gear lock plate
 - Camshaft friction gear
 - Camshaft gear
 - Idler gear plate
 - Idler gear
 - Idler gear hub
 - Crankshaft slinger
 - Crankshaft friction gear spring
 - Crankshaft friction gear
 - Crankshaft gear and key
 - Timing gear case and gasket

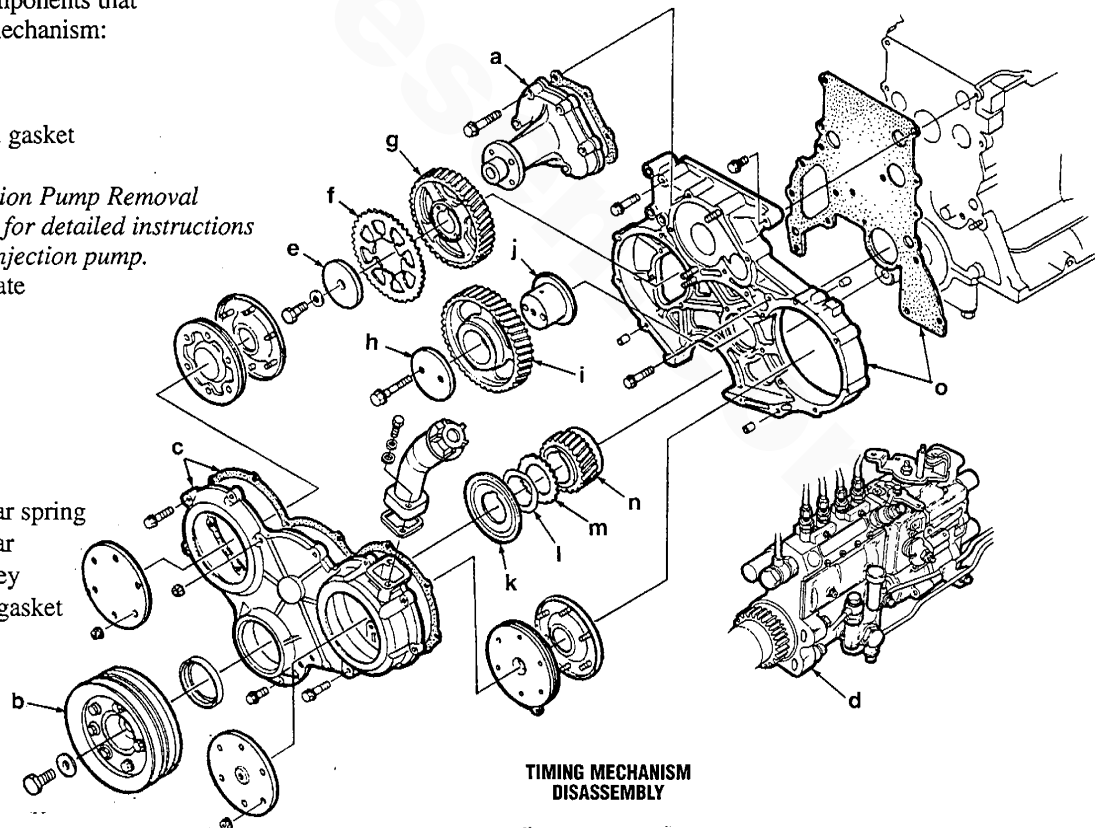

ENGINE DISASSEMBLY

35. Lubrication System Disassembly

Remove the following lubrication system components:

- a. Oil filter housing
- b. Lube oil cooler and gasket
- c. Oil filter housing gasket
- d. Sump stiffeners
- e. Lube oil sump and gasket
- f. Lube oil pump assembly
- g. Lower block
- h. Block to lower block left and right gaskets
- i. Block to lower block front and rear gaskets
- j. Oil jets
- k. Oil pressure sender
- l. Oil pressure switch

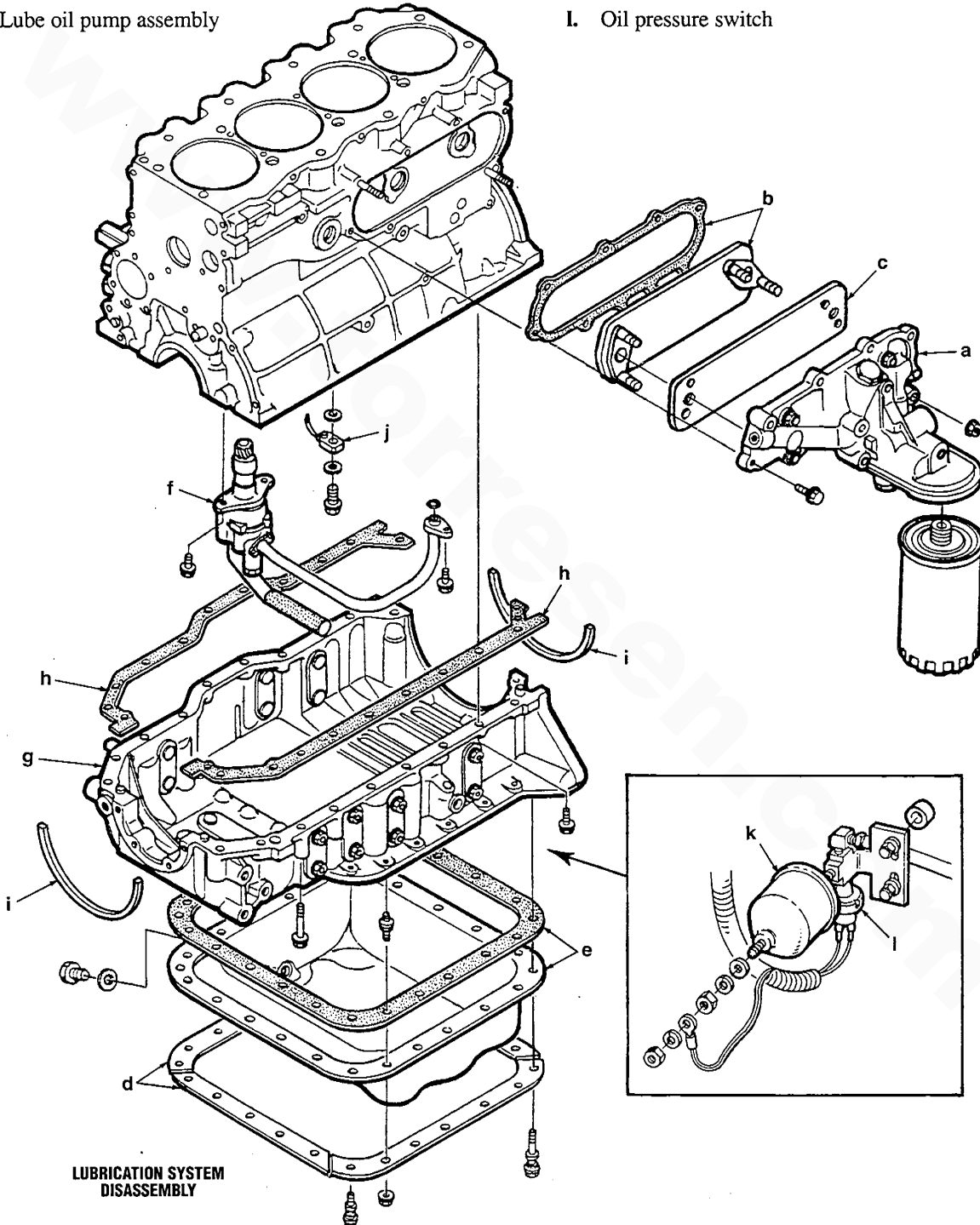

ENGINE DISASSEMBLY

36. Camshaft, Crankshaft and Pistons Disassembly

Remove the following components that are related to the camshaft, crankshaft and pistons. When removing the parts connected to the crankshaft, secure the crankshaft using the two holes in the end of the crankshaft.

- a. Back plate
- b. Crankshaft rear oil seal flange, gasket and oil seal
- c. Camshaft retaining plate
- d. Camshaft
- e. Tappets
- f. Connecting rod bearing caps
- g. Connecting rod bearings
- h. Connecting rods and pistons
- i. Piston rings
- j. Snap rings
- k. Piston Pins

Use the following method to remove a piston pin:

1. Remove the snap rings.
2. Heat the piston and connecting rod assembly to 122°– 158° F (50°– 70° C).
3. Remove the piston pin.

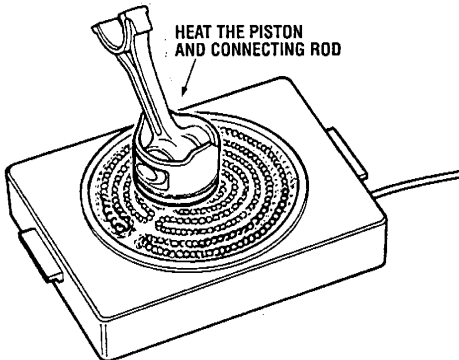

- l. Connecting rods
- m. Main bearing caps
- n. Main bearings
- o. Thrust washers
- p. Crankshaft
- q. Cylinder Liners

Cylinder liners should be removable by hand. However if difficulty is encountered, use a **cylinder liner replacer** (Mazda #49 W065 015) or equivalent and press the liner out.

CAUTION: Do not directly hit the cylinder liner with a hammer. If the cylinder liner is difficult to remove, make sure the special tool is used, otherwise it will be damaged.

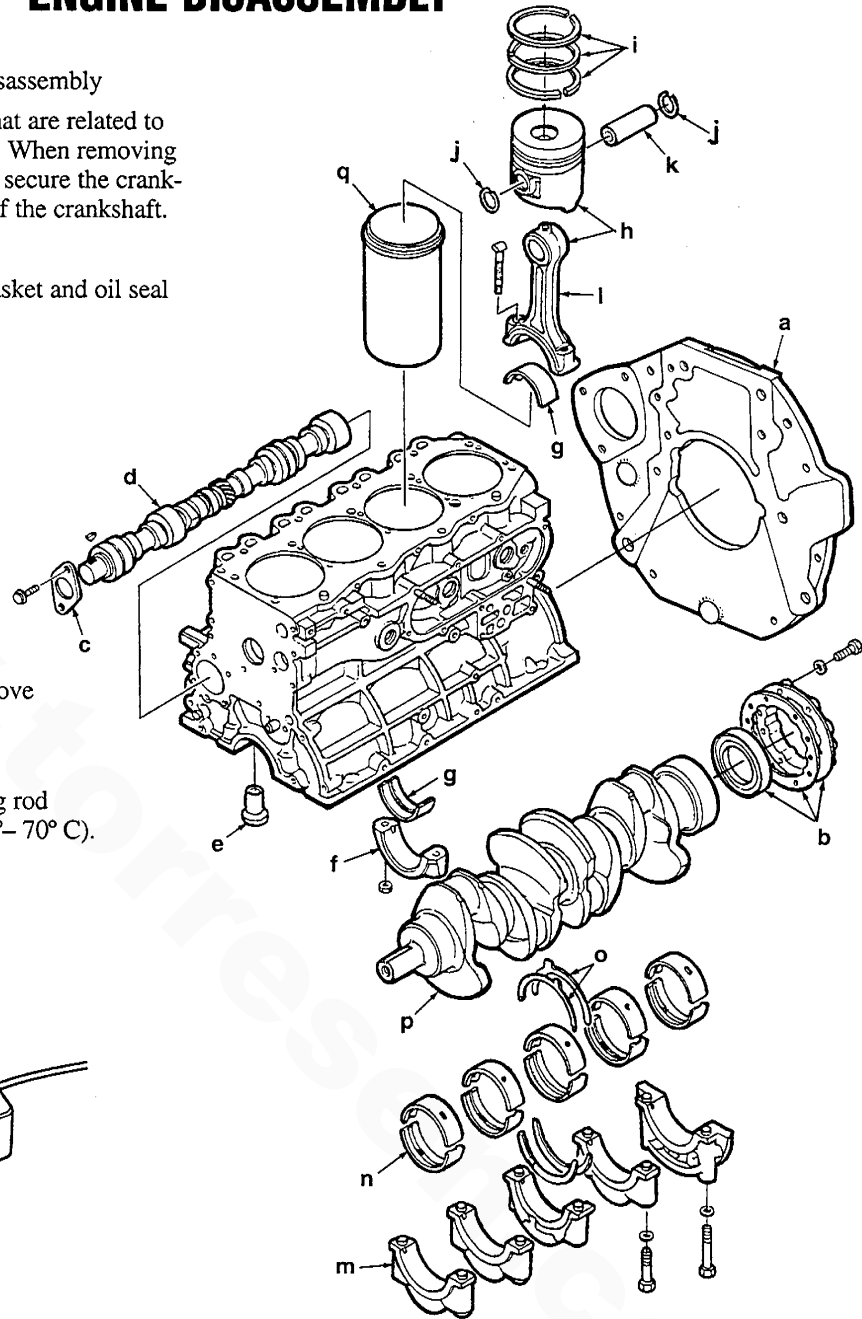

CAMSHAFT, CRANKSHAFT & PISTONS DISASSEMBLY

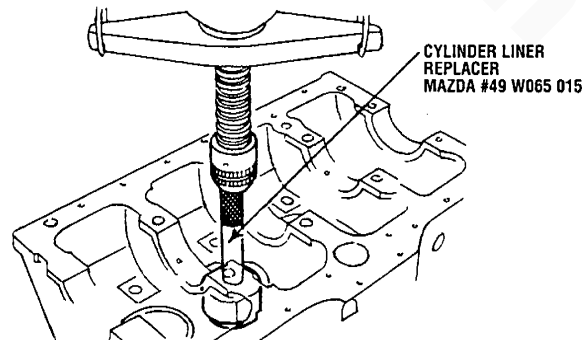

ENGINE INSPECTION AND REPAIR

GENERAL INSPECTION PROCEDURE

1. Before inspection, clean each part taking care to remove any gasket fragments, dirt, oil or grease, carbon, moisture residue, or other foreign materials.
2. Be careful not to damage the joints or sliding parts of aluminum alloy components such as the cylinder head and the pistons.
3. Inspection and repair should be done in the order indicated.

Cylinder Head

1. Inspect the cylinder head for water leakage, fuel leakage, damage and cracks. Replace it if necessary.
2. Measure the cylinder head for distortion in six directions using a thickness gauge and a straightedge as shown in the illustration.

Distortion limit: 0.004 in (0.10 mm)

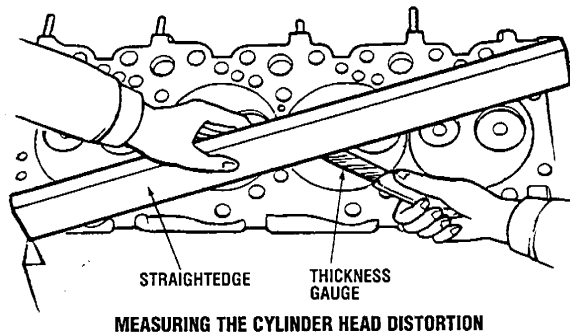
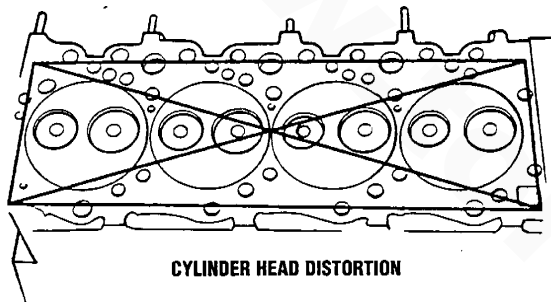

3. If the cylinder head distortion exceeds the limit, replace it.

CAUTION: Do not attempt to repair the cylinder head by milling or grinding.

Clearance between the bottom of the cylinder head and the top of the piston at TDC: 0.0303 – 0.0374 in (0.770 – 0.950 mm).

4. Measure the manifold contact surface distortion in six directions as shown in the illustration. If the distortion exceeds the limit, grind the surface or replace the cylinder head.

Distortion limit: 0.004 in (0.10 mm)

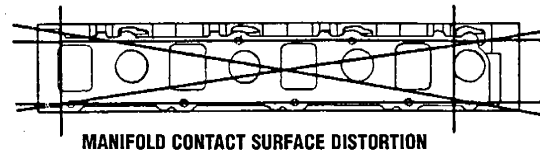

Valve Seats

1. Measure the protruding length (Dimension L) of each valve stem above the cylinder head. If the measured length is more than the specified value, take the following steps:

Dimension L (standard):

Intake: 1.892 in (48.05 mm)

Exhaust: 1.888 in (47.95 mm)

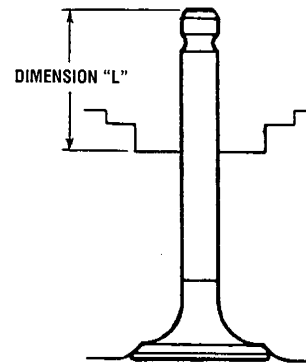

- a. When Dimension L is up to 0 – 0.020 in (0 – 0.5 mm) longer, the valve can be used as it is.
- b. When Dimension L is 0.020 – 0.059 in (0.5 – 1.5 mm) longer, set a washer [inner dia.: 0.504 in (12.8 mm), outer dia.: 1.535 in (39 mm)] under the lower spring seat to adjust Dimension L to within the standard value.

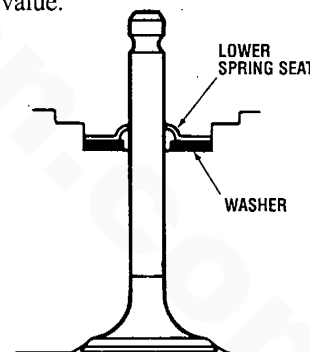

- c. When Dimension L is 0.059 in (1.5 mm) longer or more, replace the old valve with a new valve and measure Dimension L again. If the protruding length is still outside the acceptable limit, then replace the cylinder head.

2. Check the valve seat for roughness or damage. If necessary, use a valve seat cutter or valve seat grinder to restore the valve seat to the specified shape.



ENGINE INSPECTION AND REPAIR

NOTE: To check the contact width, apply a thin coating of red lead to the valve seat, and press the valve against the valve seat. Be sure not to turn the valve when doing so.

When grinding a valve seat, use a 15°, 45° or 80° valve seat cutter for the intake side, and a 12° or 60° valve seat cutter for the exhaust side or, alternately, use a valve seat grinder to grind away the roughness and/or scars (to the minimum limit) of the seat surface, always checking the contact width and the contact position while grinding.

Standard valve seat contact width:
0.0669 in (1.7 mm)

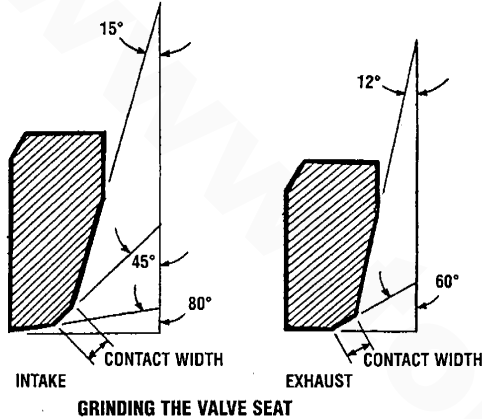

- To seat the valves, apply a thin coating of engine oil mixed with a small amount of compound to the seat surface, then lightly tap while turning the valve.

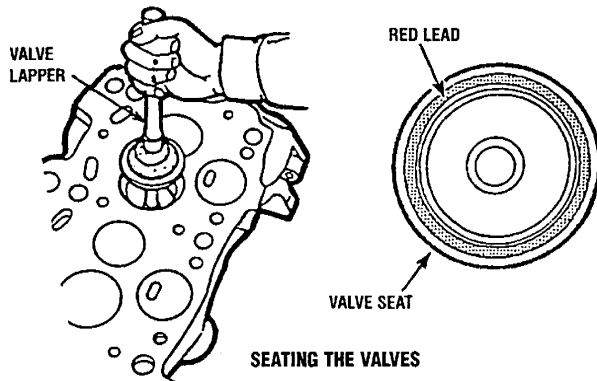

CAUTION: When seating the valve, be careful not to let compound adhere to the valve stem.

Valve contact position in relation to the valve seat must be at the center of the circumference, and the contact width must be the standard value.

Check that the protruding length of the valve is within the specified limits.

Valve and Valve Guides

- Inspection and repair of the valves.
 - Inspect each valve and replace any that show damage, bending, or dents.

- Inspect each valve for roughness or damage on its face. If a problem is slight, repair the valve with a valve refacer.

- Measure the valve length and the valve margin. Replace the valve if necessary.

Valve length:

Intake standard: 4.512 in (114.6 mm)

Exhaust standard: 4.508 in (114.5 mm)

Valve margin:

Intake limit: 0.039 in (1.0 mm)

Exhaust limit: 0.047 in (1.2 mm)

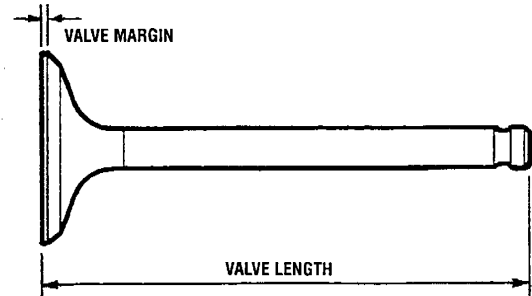

- Check the valve stem oil clearance.

- Measure the outer diameters of each valve stem.

Standard valve stem diameter:

Intake: 0.353 – 0.354 in (8.955 – 8.980 mm)

Exhaust: 0.352 – 0.353 in (8.935 – 8.960 mm)

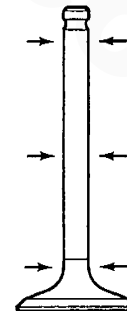
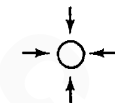
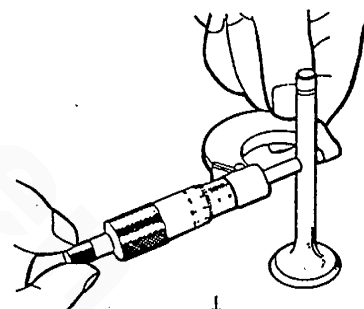

CHECKING VALVE STEM OIL CLEARANCE

- Measure the inner diameters of each valve guide.

Standard valve guide diameter:

0.355 – 0.356 in (9.018 – 9.040 mm)



ENGINE INSPECTION AND REPAIR

- c. Calculate the oil clearance by subtracting the outer diameter of the valve stem from the inner diameter of the valve guide. Replace the valve or valve guide if the oil clearance is outside the specified limits.

Oil clearance:

Intake standard:

0.0015 – 0.0033 in (0.038 – 0.085 mm)

Intake limit: 0.0050 in (0.127 mm)

Exhaust standard:

0.0023 – 0.0041 in (0.058 – 0.105 mm)

Exhaust limit: 0.0050 in (0.127 mm)

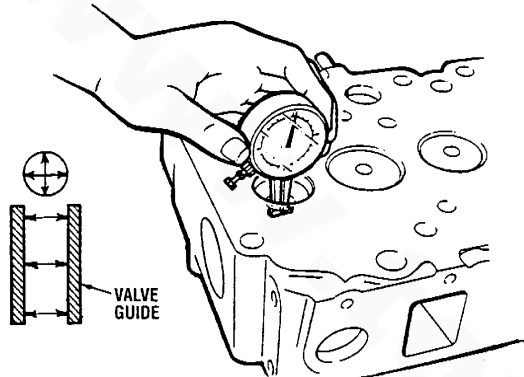

MEASURING INNER DIAMETER OF VALVE GUIDE

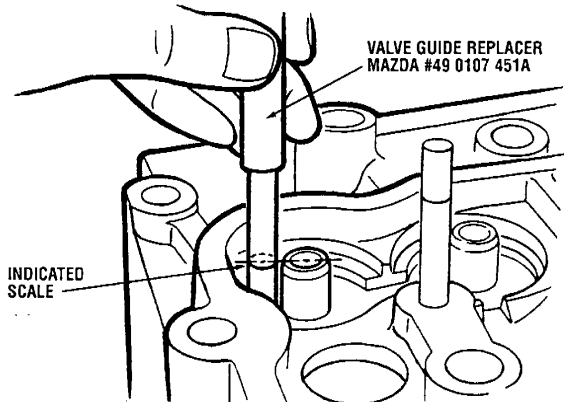
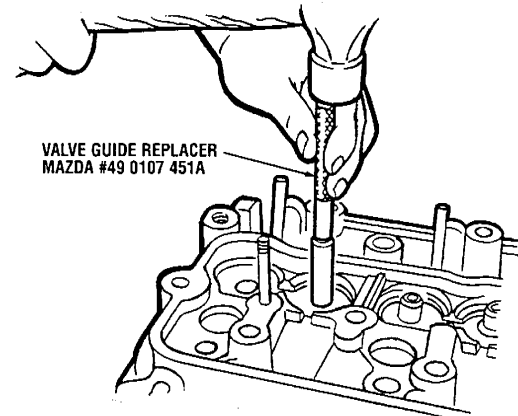

INSTALLING VALVE GUIDE

4. Replacement of valve guides.

a. *Removal*

Remove the valve guide at the side opposite the combustion chamber using the valve guide replacer (Mazda #49 0107 451A) or equivalent.

CAUTION: Do not remove a valve guide unless it is to be replaced.

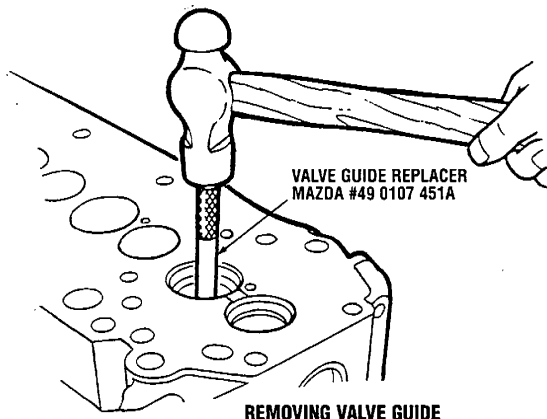

REMOVING VALVE GUIDE

b. *Installation*

Fit the clip onto the valve guide. Use the valve guide replacer (Mazda #49 0107 451A) to tap the valve guide in from the side opposite the combustion chamber until the valve guide height reaches the indicated scale [0.65 in (16.5 mm) height] on the valve guide replacer.

CAUTION: When the valve guide is replaced, recheck the clearance between the valve and the valve guide.

The valve seal should be installed after inspection and repair of the valve seat.

The intake and exhaust valve guides have the same shape.

Valve Springs

1. Inspect each valve spring for cracking or any other damage. Replace if necessary.
2. Measure each spring's free length and angle limit. Replace if necessary.

Free length:

Inner spring:

Standard: 1.83 in (46.6 mm)

Limit: 1.76 in (44.7 mm)

Outer spring:

Standard: 2.09 in (53.1 mm)

Limit: 2.01 in (51.0 mm)



ENGINE INSPECTION AND REPAIR

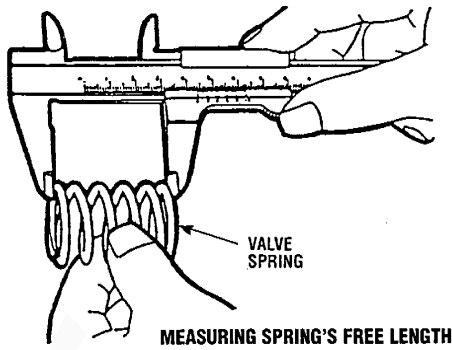

Angle limit:

Inner spring: 0.064 in (1.63 mm)

Outer spring: 0.073 in (1.85 mm)

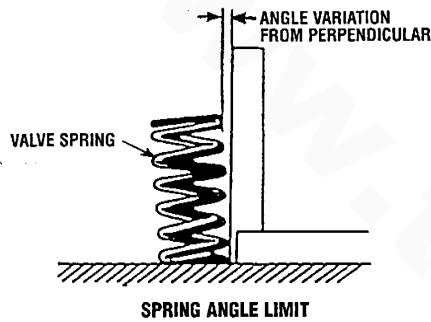

Camshaft

1. Check the camshaft for wear and damage. Measure the cam height and replace if the height is less than the limit.

Cam height:

Standard: 1.737 in (44.116 mm)

Limit: 1.717 in (43.616 mm)

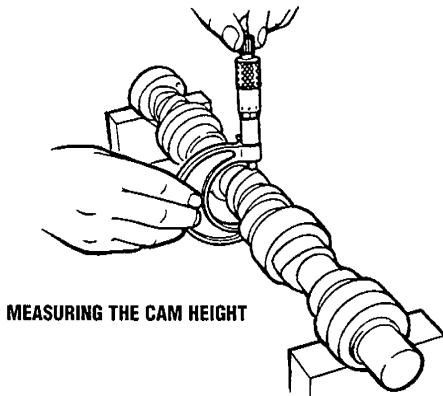

2. Check the camshaft deflection.

Limit: 0.003 in (0.08 mm) at A and B

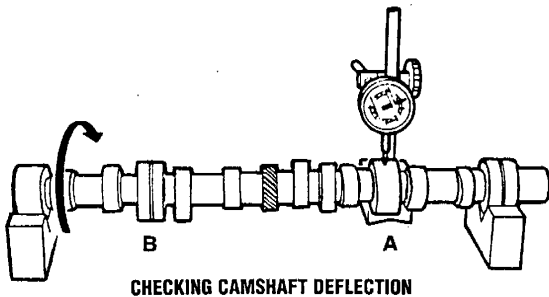

3. Check the camshaft bearing oil clearance.

- a. Measure the outer diameter of each camshaft journal.

Standard journal diameter:

No. 1: 2.044 – 2.045 in (51.910 – 51.940 mm)

No. 2: 2.034 – 2.035 in (51.660 – 51.690 mm)

No. 3: 2.024 – 2.025 in (51.410 – 51.440 mm)

No. 4: 2.014 – 2.015 in (51.160 – 51.190 mm)

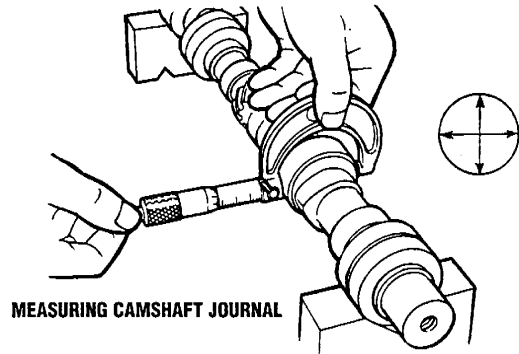

- b. Measure the inner diameter of the camshaft bearing on the cylinder block.

Standard camshaft bearing diameter:

No. 1: 2.047 – 2.048 in (52.000 – 52.030 mm)

No. 2: 2.037 – 2.038 in (51.750 – 51.780 mm)

No. 3: 2.028 – 2.029 in (51.500 – 51.530 mm)

No. 4: 2.018 – 2.019 in (51.250 – 51.280 mm)

- c. Calculate the oil clearance by subtracting the outer diameter of the camshaft journal from the inner diameter of the camshaft bearing. If the oil clearance is outside the specified limits, replace the camshaft or the cylinder block.

Standard oil clearance: 0.0024 – 0.0047 in
(0.060 – 0.120 mm)

Oil clearance limit: 0.0057 in (0.145 mm)

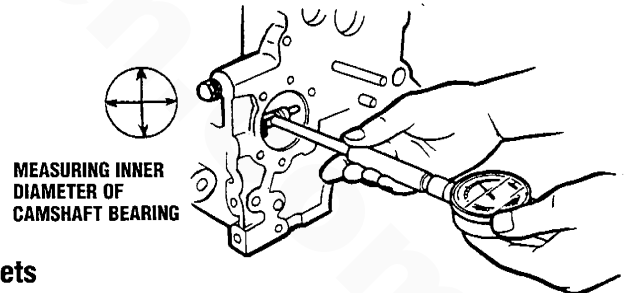

Tappets

1. Check the condition of the tappets.

- a. Check each tappet for cracking or any other damage. Replace if necessary.
- b. Check the extent of the wear on the surface that is in contact with the cam, and replace any tappet showing abnormal wear.

2. Check the oil clearance between the tappets and the tappet guides.

- a. Measure the outer diameter of each tappet.

Standard tappet outer diameter:

0.559 – 0.560 in (14.218 – 14.233 mm)

ENGINE INSPECTION AND REPAIR

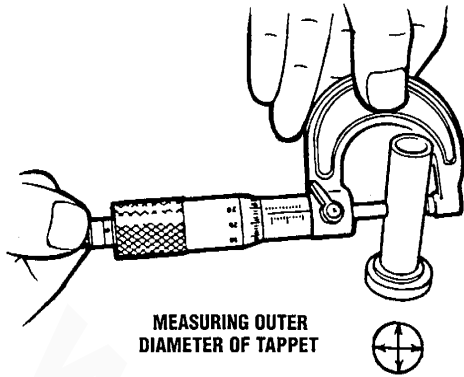

MEASURING OUTER DIAMETER OF TAPPET

- b. Measure the inner diameter of each tappet guide.

Standard inner diameter of tappet guide:
0.563 – 0.564 in (14.288 – 14.319 mm)

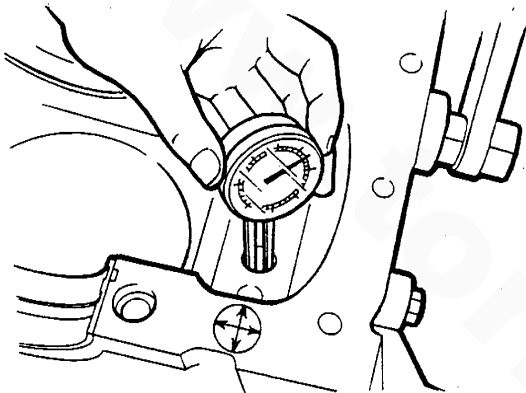

MEASURING INNER DIAMETER OF TAPPET GUIDE

- c. Calculate the oil clearance by subtracting the outer diameter of the tappet from the outer diameter of the tappet guide.

Standard oil clearance:
0.0022 to 0.0040 in (0.055 – 0.101 mm)

Oil clearance limit:
0.0059 in (0.15 mm)

Push Rods

1. Check each push rod to see if either end is worn or damaged. Replace if necessary.

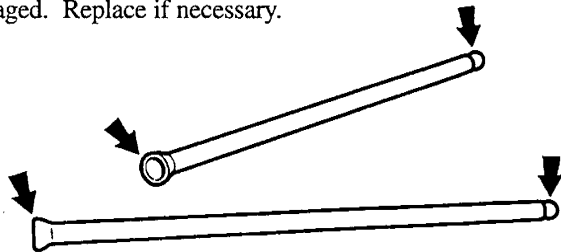

CHECKING PUSH RODS

2. Check the deflection of each push rod using a dial gauge as shown. Rotate the push rod slowly and measure the maximum deflection. If the measured value exceeds the specified limit, replace the push rod.

Deflection limit: 0.016 in (0.40 mm)

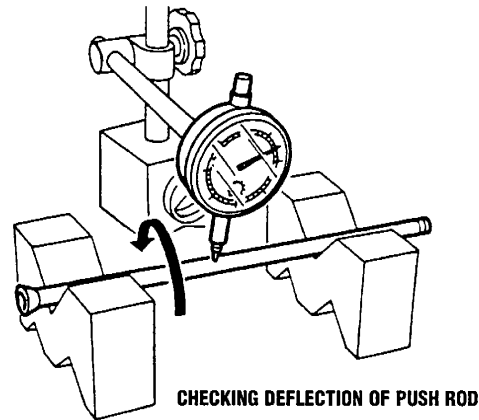

CHECKING DEFLECTION OF PUSH ROD

Rocker Arms and Shafts

1. Check the condition of the rocker arms and shafts.
 - a. Check each part of the rocker arm assembly for cracking, wear or any other damage. Replace if necessary.
 - b. Check to see if the oil holes of the rocker arm and shaft are clogged. Clean if necessary.

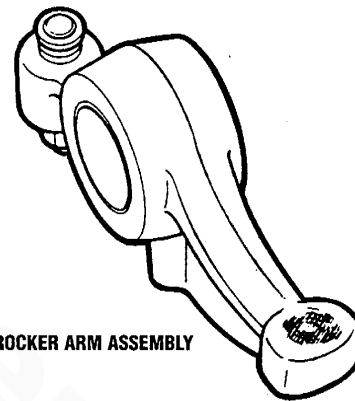

ROCKER ARM ASSEMBLY

2. Check the oil clearance between the rocker arms and shafts.

- a. Measure the outer diameter of each rocker shaft.

Standard rocker shaft diameter:
0.746 – 0.747 in (18.959 – 18.980 mm)

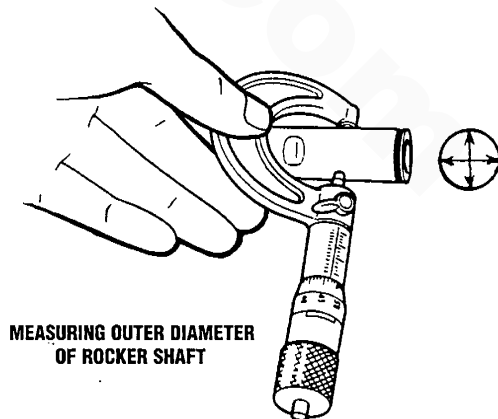

MEASURING OUTER DIAMETER OF ROCKER SHAFT

ENGINE INSPECTION AND REPAIR

- b. Measure the inner diameter of each rocker arm bushing.

Standard rocker arm bushing diameter:
0.748 – 0.749 in (19.000 – 19.021 mm)

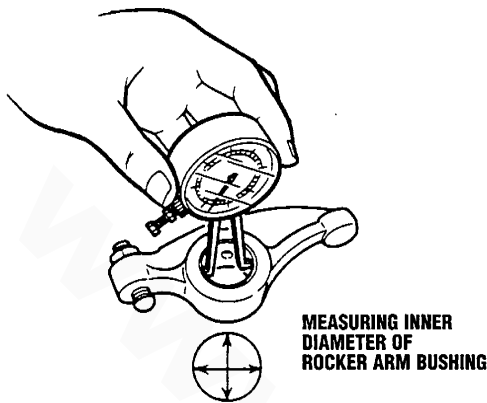

- c. Calculate the oil clearance by subtracting the outer diameter of the rocker shaft from the inner diameter of the rocker arm bushing. If the oil clearance is outside the specified limits, replace the rocker arm bushing or the rocker arm shaft.

Standard oil clearance:
0.0002 – 0.0024 in (0.020 – 0.062 mm)

Oil clearance limit:
0.0039 in (0.10 mm)

3. Replace the rocker arm bushing.
- Remove the bushing by pressing it out using a pipe having an appropriate diameter.

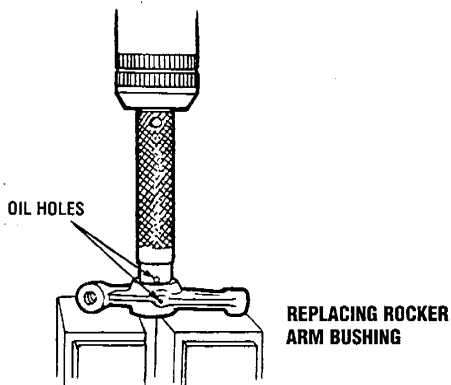

- Align the oil holes of the rocker arm and a new bushing so that the oil hole of the bushing will be open to the hole in the rocker arm when installed—oil must be able to flow through these openings.
- When the press-fitting is complete, correct the diameter of the bushing with a pin hole grinder or a spiral expansion reamer so that the clearance between the bushing and the shaft meets the standard value.

Standard clearance:
0.0008 – 0.0024 in (0.020 – 0.062 mm)

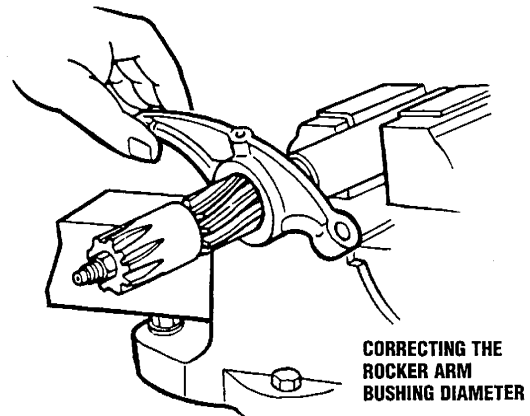

Pistons and Piston Rings

- Check the condition of the pistons and the piston rings.
 - Check the sliding surface of the piston, ring grooves and other parts of the piston for cracking or any other damage. Replace the piston if necessary.
 - Check the piston rings for broken parts, thermal damage and wear. Replace the rings if necessary.

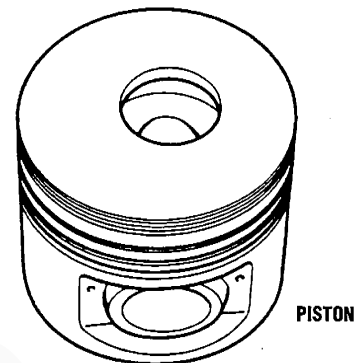

- Check the clearance between the piston and the cylinder liner.
 - Measure each piston's diameter at the skirt side of the piston 1.06 in (27 mm) above the bottom end of the piston.

Standard piston outer diameter:
Z: 3.9345 – 3.9350 in (99.937 – 99.950 mm)
Y: 3.9350 – 3.9355 in (99.950 – 99.963 mm).

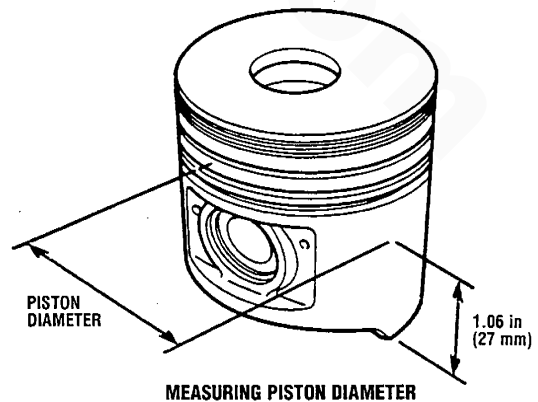

ENGINE INSPECTION AND REPAIR

- b. Measure the inner diameter of the corresponding cylinder liner. (See *Cylinder Liners* in this section.)
- c. Calculate the piston clearance. If the clearance exceeds the limit, replace the piston or the cylinder liner.

Piston clearance:

Standard:

0.0020 – 0.0030 in (0.050 – 0.076 mm)

Limit:

0.0017 and 0.0032 in (0.044 and 0.082 mm)

NOTE: Oversized pistons and cylinder liners are not available. Z or Y marks are stamped on top of the piston.

3. Checking the piston ring end gap.

Position the piston ring in the cylinder liner and measure the piston ring end gap.

- a. When reusing a piston ring, measure the end gap when the ring is set in the most worn part of the cylinder liner.
- b. When replacing a piston ring, measure the end gap when the ring is set in the least worn part of the cylinder liner.

Piston ring end gap limit: 0.059 in (1.5 mm)

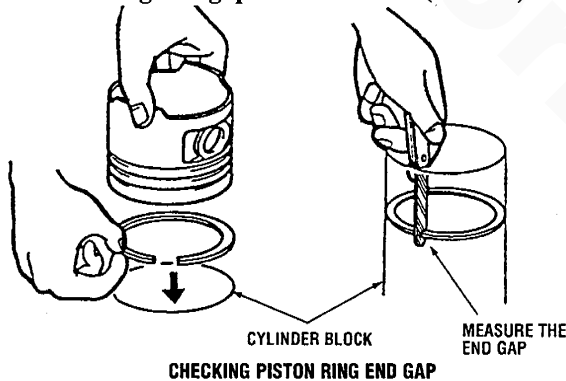

CHECKING PISTON RING END GAP

4. Check the clearance between the piston ring grooves and the piston rings.

- a. Fit the piston ring on the piston.
- b. Measure the clearance between the piston ring groove and the piston ring with a feeler gauge. If the clearance exceeds the specified limit, replace the piston or the whole set of piston rings.

Clearance limit:

Top ring: 0.0098 in (0.25 mm)

Second ring: 0.0079 in (0.20 mm)

Oil ring: 0.0079 in (0.20 mm)

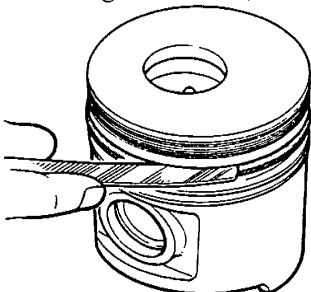

CHECKING PISTON RING AND GROOVE CLEARANCE

Cylinder Liners

1. Check the interior of each cylinder liner for scratches, wear or any other damage. Replace if necessary.
2. Measure the inner diameter of each cylinder liner at three positions: top, middle and bottom. At each position, measure the inner diameter in X-X and Y-Y directions (see illustration) for a total of six measurements.

a. Extent of wear.

The extent of wear of a cylinder liner equals the maximum measured value minus the maximum standard value.

Standard cylinder liner inner diameter:

Z: 3.9370 – 3.9375 in (100.000 – 100.013 mm)

Y: 3.9375 – 3.9380 in (100.013 – 100.026 mm)

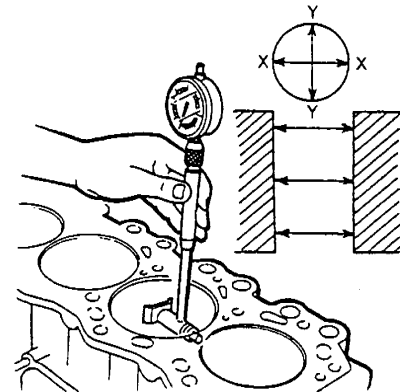

MEASURING CYLINDER LINER INNER DIAMETER

b. Extent of uneven wear

The extent of uneven wear of a cylinder liner equals the maximum measured value minus the minimum measured value. If the extent of unequal wear exceeds 0.0079 in (0.20 mm), replace the cylinder liner.

NOTE: Z or Y is painted on the outside of each cylinder liner.

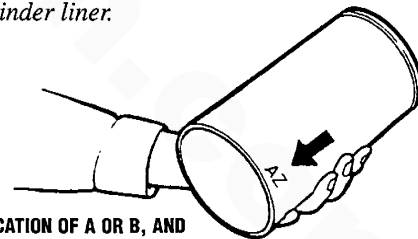

LOCATION OF A OR B, AND Y OR Z ON CYLINDER LINER

3. Check the clearance between the cylinder liners and the cylinders.

- a. Measure the outer diameter of each cylinder liner.

Standard outer diameter of cylinder liner:

A type: 4.0777 – 4.0782 in (103.474 – 103.487 mm)

B type: 4.0743 – 4.0748 in (103.487 – 103.500 mm)

NOTE: A or B is painted on the outside of each cylinder liner.



ENGINE INSPECTION AND REPAIR

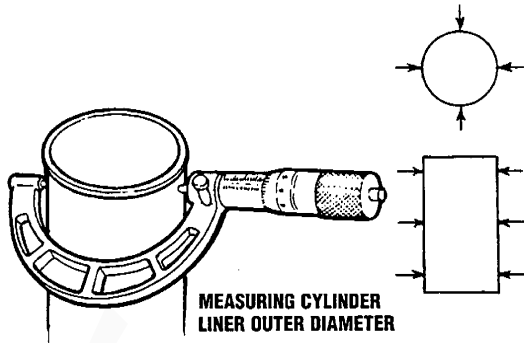

b. Measure the inner diameter of the cylinder.

Standard cylinder bore:

A type: 4.0748 – 4.0753 in
(103.500 – 103.513 mm)

B type: 4.0753 – 4.0758 in
(103.513 – 103.525 mm)

NOTE: A or B is stamped on the cylinder block above each cylinder.

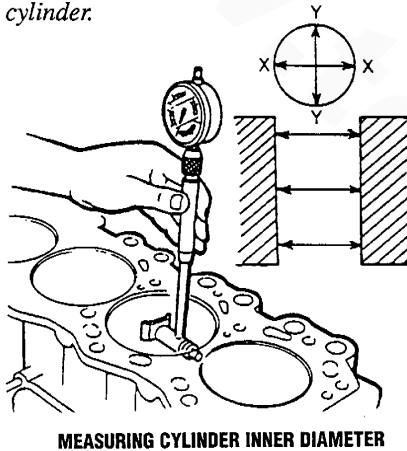

c. Calculate the oil clearance by subtracting the outer diameter of the cylinder liner from the inner diameter of the cylinder. If the oil clearance exceeds the limit, replace the cylinder liner or the cylinder block.

Clearance limit:

A type: 0.00051 in (0.013 mm)

B type: 0.00154 in (0.039 mm)

Connecting Rods

1. Check the side surfaces of the big end and the small end of each connecting rod for cracking or any other damage. Replace if necessary.
2. Check the connecting rod for bending and torsion using a connecting rod aligner. If bending or torsion exceeds the specified limit, correct with a press, or replace.

Connecting rod bending limit:

0.002 in (0.05 mm) per 1.97 in (50 mm)

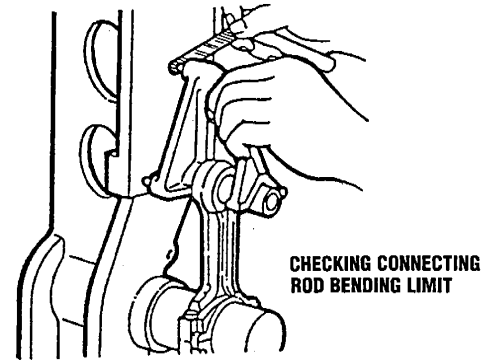

Connecting rod torsion limit:

0.002 in (0.05 mm) per 1.97 in (50 mm)

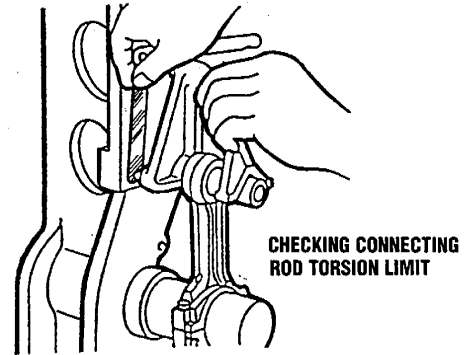

3. Check the clearance between the connecting rod bushings and the piston pins.

a. Measure the inner diameter of the bushings.

Standard connecting rod bushing diameter:

1.3391 – 1.3399 in (34.012 – 34.033 mm)

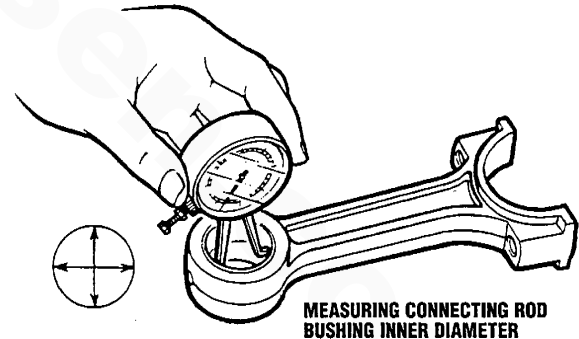

b. Measure the outer diameter of the piston pins.

Standard piston pin diameter:

1.3383 – 1.3386 in (33.993 – 34.000 mm)

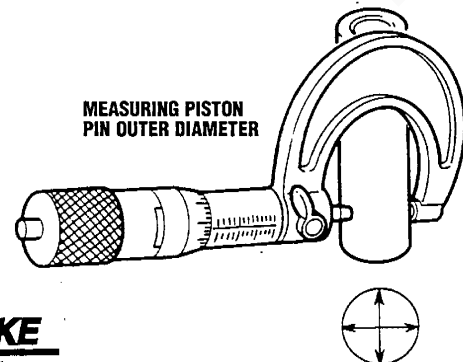

ENGINE INSPECTION AND REPAIR

- c. Calculate the oil clearance by subtracting the outer diameter of the bushings from the inner diameter of the piston pins. If the oil clearance is outside the specified limits, replace the bushing or the piston pin.

Standard clearance:

0.0005 – 0.0016 in (0.012 – 0.040 mm)

Clearance limit:

0.0024 in (0.06 mm)

4. Replacement of the connecting rod bushing.
 - a. Use a press and a suitable pipe having a diameter of 1.22 – 1.26 in (31 – 32 mm).

⚠ CAUTION: Before installing, apply a coating of clean engine oil to the connecting rod bushing and the connecting rod. Align the connecting rod bushing oil hole with the connecting rod oil hole.

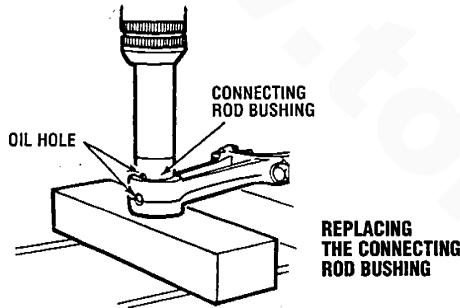

5. After pressing the bushing in, correct its inner diameter with a spiral expansion reamer so that the clearance will be within the standard value.

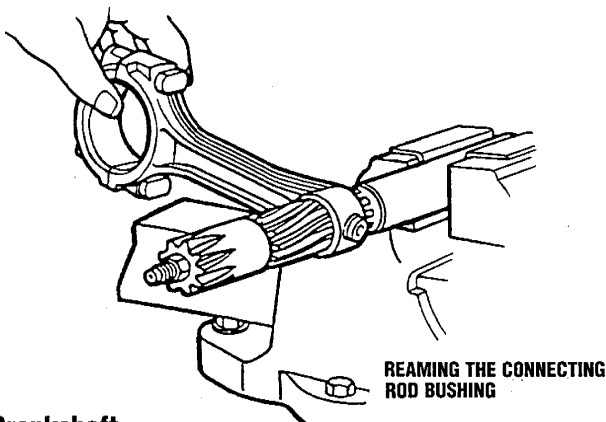

Crankshaft

1. Check the condition of the crankshaft.
 - a. Check each part of the crankshaft for cracking, cuts or any other damage. Replace if necessary.
 - b. Check to see if the oil holes are clogged. Clean if necessary.

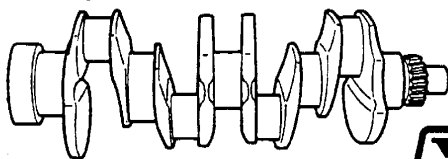

CRANKSHAFT

2. Check the crankshaft for deflection.
 - a. Support both ends of the crankshaft on V-blocks.
 - b. Set a dial gauge on the middle main journal and measure the deflection by slowly turning the crankshaft. Read the maximum value and if the deflection exceeds the specified limit, replace the crankshaft.

Deflection limit: 0.0020 in (0.05 mm)

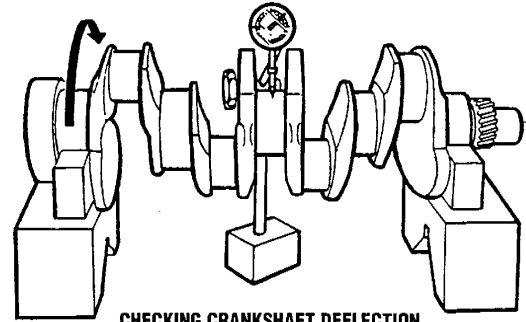

3. Check the crankshaft for wear.
 - a. Measure wear on the crankpin (see illustration). If wear exceeds the limit, replace or grind the crankshaft until it agrees with the undersize bearing.

Standard journal diameters:

- (1) Main journal diameter
2.984 – 2.985 in (75.805 – 75.825 mm)
- (2) Crankpin diameter
2.4060 – 2.4065 in (61.112 – 61.125 mm)
- (3) Rear flange oil seal sliding surface
3.9985 – 3.9995 in (101.562 – 101.587 mm)

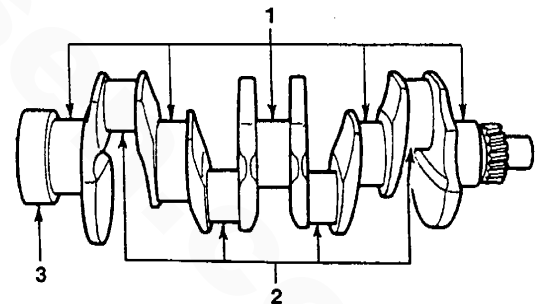

STANDARD JOURNAL DIAMETERS

Journal wear limit: 0.0012 in (0.03 mm)

Journal grinding limit: 0.0295 in (0.75 mm)

Undersize bearings:

- 0.010 in (0.25 mm), 0.020 in (0.50 mm),
0.0295 in (0.75 mm)

⚠ CAUTION: When grinding a journal or pin, pay attention to each fillet R dimension.

Fillet R dimension:

- Journal:** 0.146 – 0.157 in (3.7 – 4.0 mm)
Pin: 0.126 – 0.138 in (3.2 – 3.5 mm)



ENGINE INSPECTION AND REPAIR

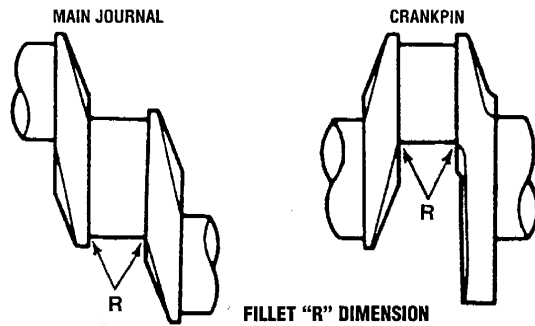

4. Check the inside surfaces of the main and connecting rod bearings for streaking, flaking, pin holes, etc. Replace all bearings as a set if necessary.

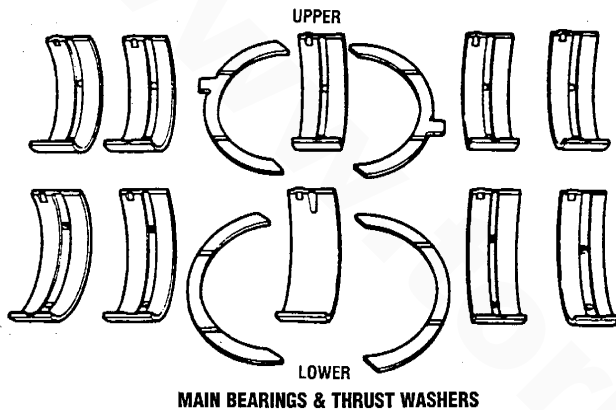

Rear Oil Seal – Crankshaft

1. Inspecting the oil seal
 - a. Check the oil seal lip for wear, fraying or other damage and, if necessary, replace it.
2. Oil seal replacement
 - a. Strike out the old rear oil seal with a suitable mandrel.
 - b. Apply engine oil onto the outside of a new seal and press-fit the seal in the rear oil seal flange equally.

NOTE: In case the crankshaft is worn, the oil seal must be fitted on the oil seal flange with its fitting position moved by approximately 0.1181 in (3mm) so that the seal does not touch the worn down portion of the crankshaft.

An alternative is to install a metal seal saver on the crankshaft to restore it. This will make the surface of the crankshaft smooth again.

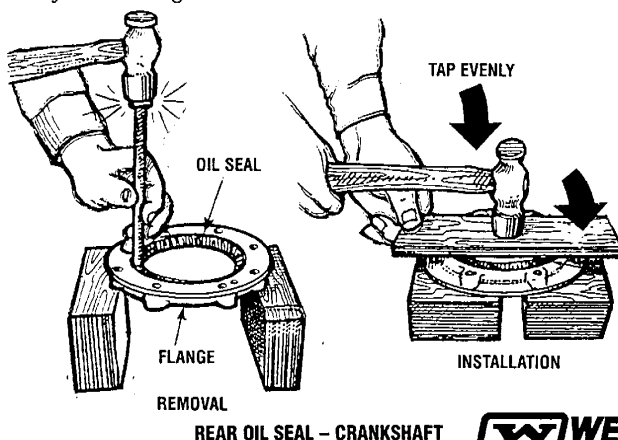

REAR OIL SEAL – CRANKSHAFT

Cylinder Block

1. Cylinder block inspection and repair.
 - a. Check each cylinder for dampness, damage and cracks. Replace the cylinder block if necessary.
 - b. Measure the distortion of the top surface of the cylinder block in six directions using a thickness gauge and a straightedge (see illustration). If the distortion exceeds the limit, replace the cylinder block.

Distortion limit: 0.0039 in (0.10 mm)

CAUTION: Do not grind the surface of the cylinder block. If ground, the pistons will hit the valves.

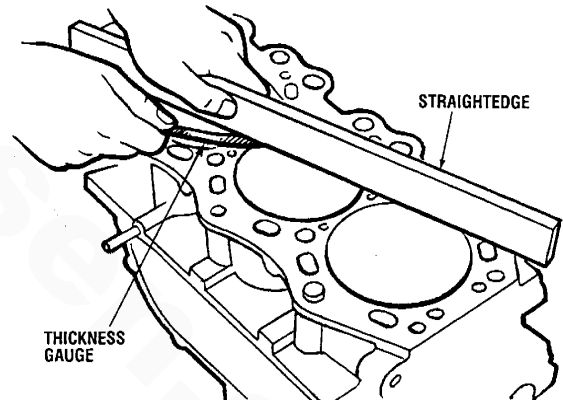
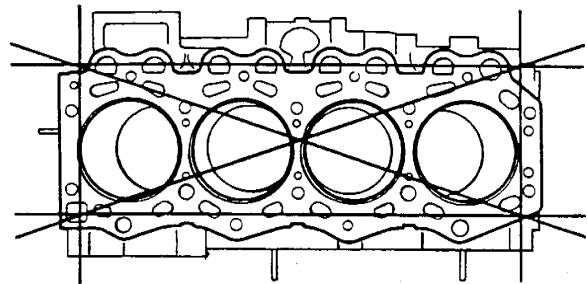

MEASURING CYLINDER BLOCK DISTORTION

Flywheel

1. Check the outer-facing side of the flywheel for scratches, dirt, wear of the ring teeth or any other damage. Replace if necessary.
2. Measure the distortion of the outer-facing side of the flywheel with a thickness gauge and a straightedge. If distortion exceeds the limit, replace the flywheel.

Limit: 0.008 in (0.20 mm)

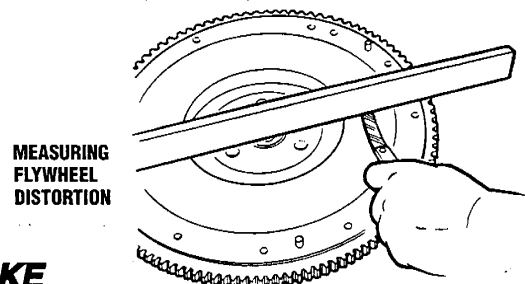

MEASURING FLYWHEEL DISTORTION



ENGINE INSPECTION AND REPAIR

Timing Gears

1. Check the timing gears for cracking, damage to the teeth, or any other damage. Replace if necessary.

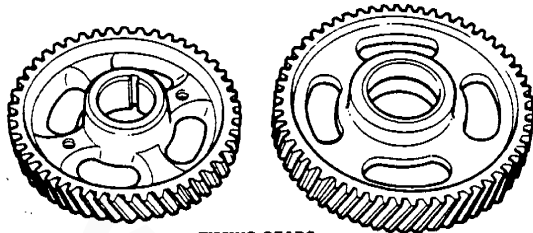

TIMING GEARS

2. Measure the backlash of the idle gear and the other gears with a dial gauge. Gears not being measured should be kept disengaged.

Backlash:

Standard: 0.0039 – 0.0079 in (0.10 – 0.20 mm)

Limit: 0.0118 in (0.30 mm)

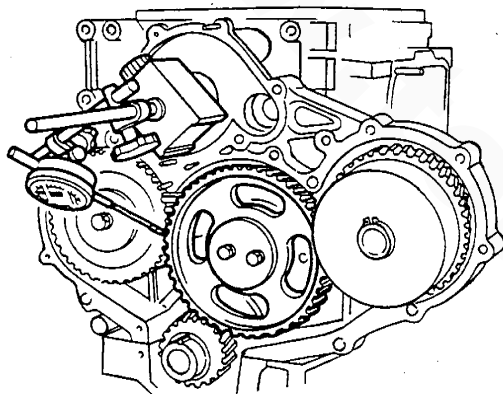

MEASURING TIMING GEAR BACKLASH

3. Measure the end play of the idler gear with a dial gauge.

Standard end play:

0.0020 – 0.0071 in (0.05 – 0.18 mm)

End play limit: 0.0098 in (0.25 mm)

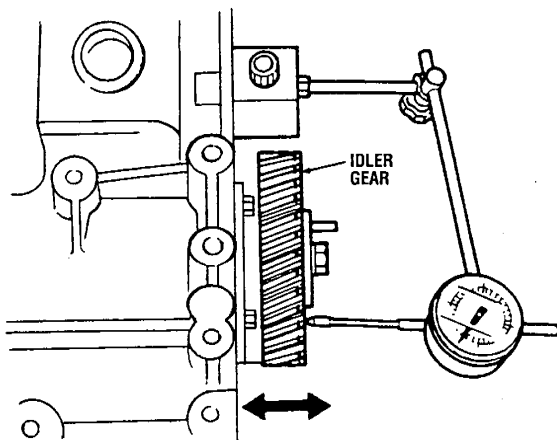

MEASURING IDLER GEAR END PLAY

4. Check the oil clearance between the idler gear and the idler gear hub.
 - a. Measure the inner diameter of the idler gear.

Standard idler gear diameter:

1.732 – 1.734 in (44.009 – 44.034 mm)

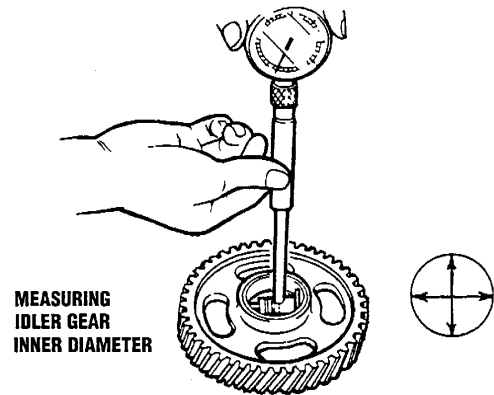

MEASURING IDLER GEAR INNER DIAMETER

- b. Measure the outer diameter of the idler gear hub.

Standard idler gear hub diameter:

1.730 – 1.731 in (43.950 – 43.975 mm)

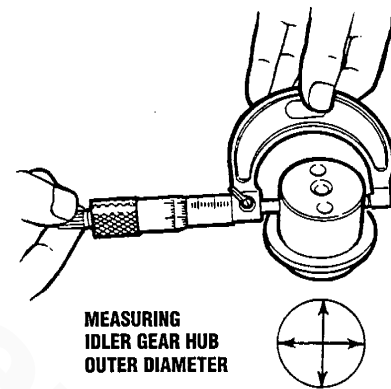

MEASURING IDLER GEAR HUB OUTER DIAMETER

- c. Calculate the oil clearance by subtracting the outer diameter of the idler gear hub from the inner diameter of the idler gear. If the clearance exceeds the specified limit, replace the idler gear bushing and the idler gear hub.

Oil clearance:

Standard: 0.0013 – 0.0033 in

(0.034 – 0.084 mm)

Limit: 0.0059 in (0.15 mm)

Oil Jets

1. Inspect each oil jet for cracking or any other damage.
2. Check that the valve in the oil jet moves smoothly.

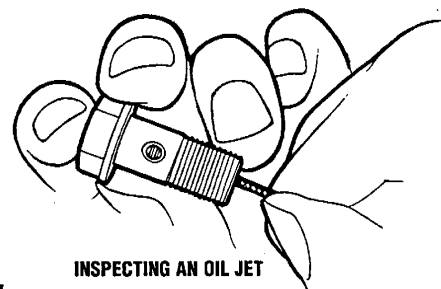

INSPECTING AN OIL JET



ENGINE REASSEMBLY

GENERAL REASSEMBLY PROCEDURE

- Clean or wash the parts to be reassembled. Apply lubricating oil when specified or as needed to the surfaces of moving parts during reassembly. Heavily oil sliding, turning, rotating and reciprocating parts; lightly oil head bolts and other fasteners except those that penetrate into the water jacket. These fasteners should be sealed with *Permatex No. 2* or a high-tack equivalent. Make sure that moving parts, after assembly onto the engine, are not subject to binding or excessive tension.
- Carefully check gaskets, packings and oil seals, even if checking is not specified. Use new gaskets, lockwashers and O-rings.
- Be careful not to mix bolts and nuts. Both metric and S.A.E. bolts are used on various engine assemblies.
- Replace plain bearings if they are peeling, burned or otherwise damaged.
- Reassemble parts (e.g. pistons, piston rings, bearings, bearing caps) in their proper order, positions and directions relative to the engine block. Avoid reversed orientation — note that the cylinder head gasket, head bolt washers and thermostat are assymetrical. Any mating marks that were drawn or scribed during disassembly should be positioned correctly for reassembly. Position gaskets carefully, especially the head gasket, so they will not be damaged during assembly.
- Inspect all critical clearances, end plays, oil clearances, and bends.
- Use liquid sealants when specified or needed on nuts, bolts and gaskets. Use *Permatex No. 2* or equivalent. Don't use tape sealants. Refer to *SEALANTS & LUBRICANTS* in this manual.
- Tighten the bolts and nuts on the important parts of the engine to the specified torques using a reliable torque wrench. Tighten fasteners in the specified torque sequences, and in three steps: 1/2, 2/3, and 1/1 torque. Exceptions are torque-to-yield head bolts and rocker arm shaft fasteners. The former are torqued as indicated. The latter – rocker shaft fasteners – should be brought down in very small increments, working from the center bolts out. Where a tightening torque is not specified, tighten evenly to an ordinary torque.
- After completion of reassembly, recheck for any abnormalities. Prepare for starting the engine, and idle the engine sufficiently for a test run.

ENGINE REASSEMBLY

Valve Seals

NOTE: Always replace the valve seals during an engine overhaul.

1. Apply engine oil to the valve guides.
2. Install the lower spring seats.
3. Using the **valve seal pusher** (Mazda #49 SE01 160), install the valve seals to the intake valve guides.

CAUTION: Be sure to use the special tool for the installation of the valve seals. If a valve seal is not installed correctly, oil might leak down into the cylinders during operation.

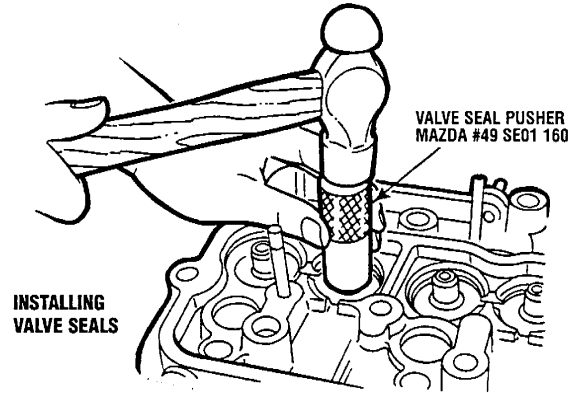

Valves

1. Insert the valve after applying molybdenum disulphide grease to the valve stem.
2. Install the valve springs and the upper spring seats.
3. Using the **valve spring lifter** (Mazda #49 0636 100A) and **pivot** (Mazda #49 0107 222A) or an appropriate valve spring compression tool, press each valve spring, then install the valve cotters securely, and the stem caps.

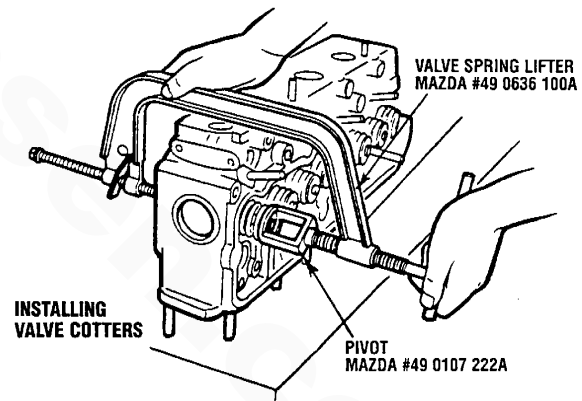

Oil Jets

Install the oil jets to the cylinder block.

NOTE: Make sure the protrusion on the oil jet is in its hole in the cylinder block.

Oil jet tightening torque:

8.1 – 13.0 ft-lb (1.2 – 1.8 m-kg)

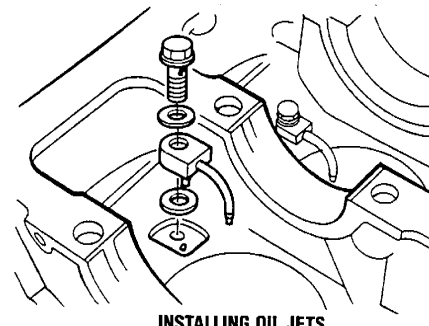

ENGINE REASSEMBLY

Tappets

Apply engine oil to the tappets and insert them into their original locations.

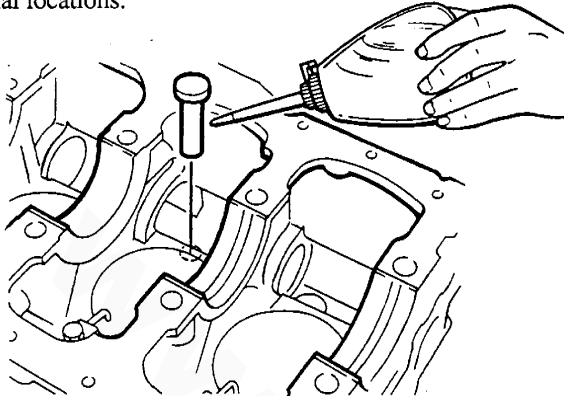

INSTALLING TAPPETS

Camshaft

1. Apply engine oil to the camshaft and insert it into the cylinder block.

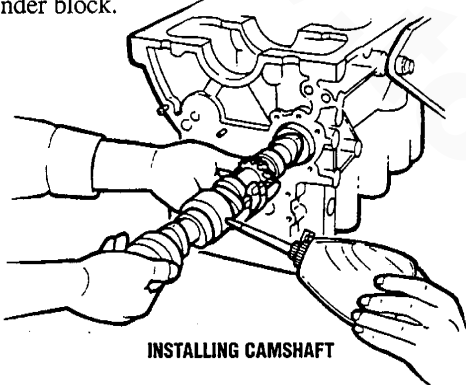

INSTALLING CAMSHAFT

2. Install the camshaft retaining plate with the flush side facing the cylinder block.

Camshaft retaining plate tightening torque:
14 – 19 ft-lb (1.9 – 2.6 m-kg)

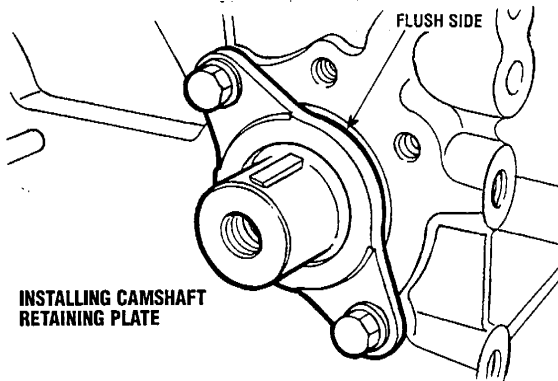

INSTALLING CAMSHAFT
RETAINING PLATE

Crankshaft

1. Install the main bearings.

CAUTION: Make sure no oil or dirt is on the back surface of the main bearings.

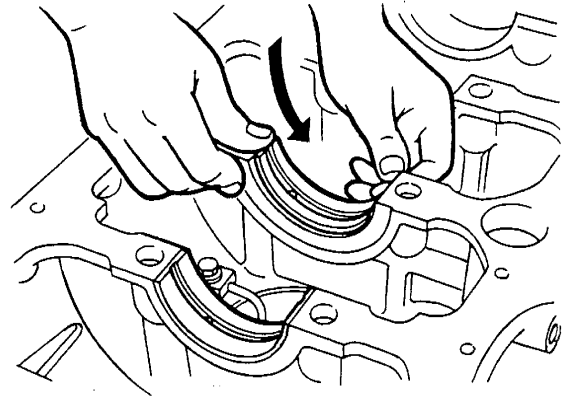

INSTALLING MAIN BEARINGS

2. Check the oil clearance of the crankshaft and main bearings with a plastigauge.
 - a. Remove any foreign material from the main journal or bearing.
 - b. Position the plastigauge on top of the main journal (in the journal's axial direction).
 - c. Set the main bearing caps in position, then tighten the bolts to the specified torque in the sequence shown in the illustration.

Main bearing cap tightening torque:
72 – 77 ft-lb (10.0 – 10.7 m-kg)

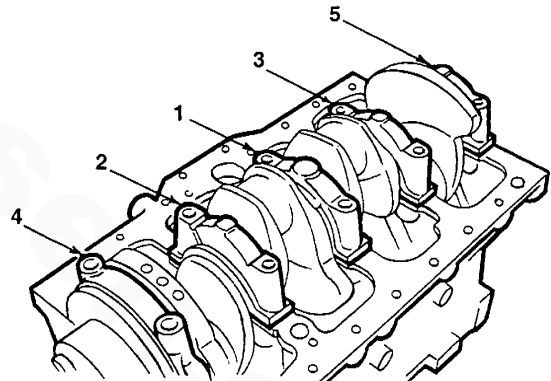

MAIN BEARING CAP TIGHTENING SEQUENCE

- d. Remove the main bearing tight cap and measure the oil clearance.

Standard main bearing cap oil clearance:
0.0023 – 0.0035 in (0.059 – 0.090 mm)

Oil clearance limit: 0.0047 in (0.12 mm)

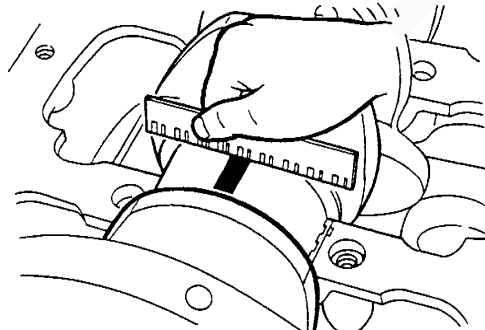

MEASURING THE OIL CLEARANCE

ENGINE REASSEMBLY

- e. If the oil clearance exceeds the limit, replace the entire set of main bearings, then measure the oil clearance again.

If the entire set of main bearings is replaced and the oil clearance still exceeds the oil clearance limit, grind the crankshaft and use undersize bearings.

⚠ CAUTION:

- a) Position the plastigauge horizontally on the crankshaft, away from the oil hole.
- b) Do not rotate the crankshaft when measuring the oil clearance.
- c) Install the main bearing cap, referring to the cap number and arrow.

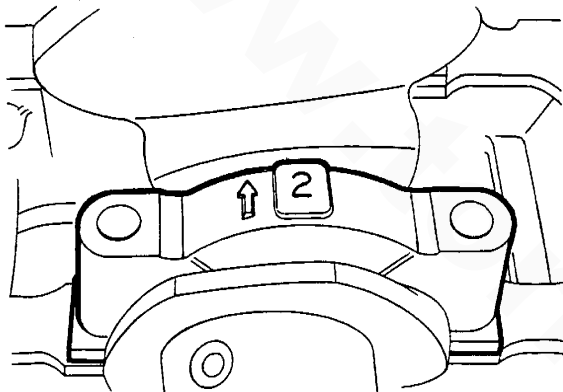

MAIN BEARING CAP NUMBER & ARROW

3. After checking and correcting the oil clearance, apply engine oil to the main bearings and main journals, then install the crankshaft.

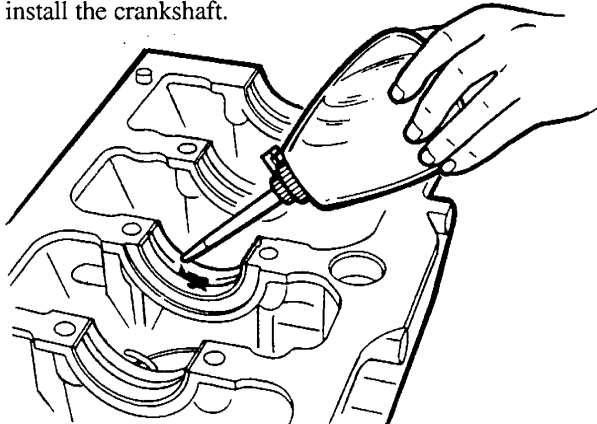

OILING THE MAIN BEARINGS

4. Apply engine oil to the thrust washers, then install them to the center part of the main journal.

⚠ CAUTION: Install the thrust washers so that the inner surface of the oil groove faces the cylinder block.

5. With the main bearing caps set, move the crankshaft backward and forward to improve the setting. Then tighten the bolts to the specified torque.
6. Measure the end play of the crankshaft, and confirm that it is within the standard range. Also check that the crankshaft turns lightly.

Standard crankshaft end play:

0.0055 – 0.0150 in (0.14 – 0.39 mm)

End play limit: 0.015 in (0.40 mm)

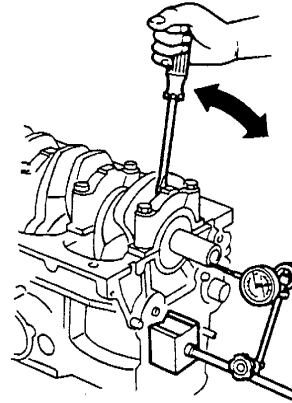

MEASURING CRANKSHAFT END PLAY

7. If the end play is not within the standard range, select a suitable thrust washer.

Standard thrust washer width:

0.0896 – 0.0915 in (2.275 – 2.325 mm)

Oversize thrust washer width:

0.0966 – 0.0985 in (2.453 – 2.503 mm)

⚠ CAUTION: When replacing the thrust washers on one side only, always install them at the rear side.

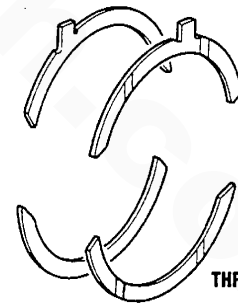

THRUST WASHERS

Cylinder Liners

1. If a new cylinder liner is to be installed, select a cylinder liner with the same letter (A or B) as is printed on top of the cylinder block.

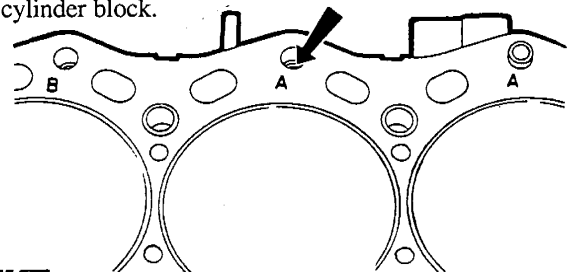

ENGINE REASSEMBLY

2. Apply engine oil thoroughly to the cylinder liners.

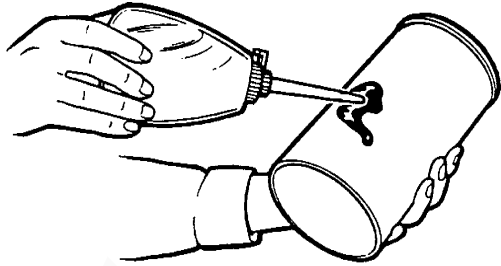

OILING THE CYLINDER LINERS

3. Check to see that the cylinder walls are free of carbon and dirt. Then install the cylinder liners to their original locations, making sure the letters on the cylinder liners match the letters on the cylinder block.



INSTALLING CYLINDER LINERS

Pistons and Connecting Rods

1. Assemble the pistons and connecting rods.
 a. Heat the piston to 122° – 158° F (50° – 70° C).

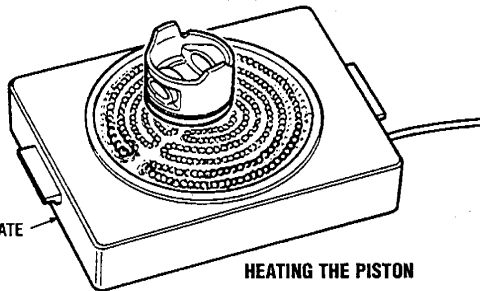

HOT PLATE

HEATING THE PISTON

- b. Apply engine oil to the small end of the connecting rod and around the piston.
 c. Insert a snap ring into one of the piston pin holes.

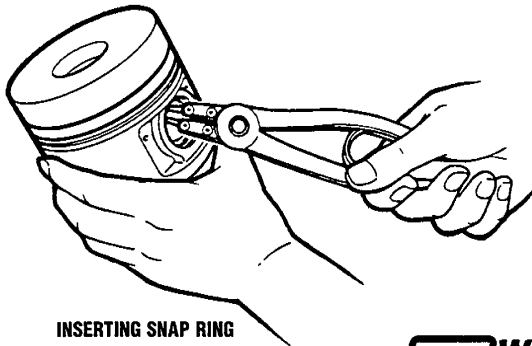

INSERTING SNAP RING

- d. Position the piston and connecting rod assembly so that the matching number on the big end of the connecting rod faces the same side as the combustion chamber cutout.

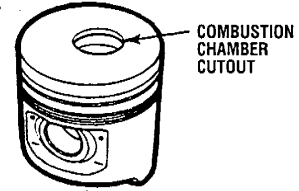

COMBUSTION CHAMBER CUTOUT

POSITIONING PISTON & CONNECTING ROD

MATCHING NUMBER

- e. Assemble the piston and connecting rod with the piston pin and lock the snap rings so the pin won't come out.

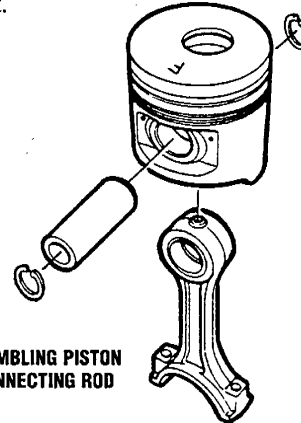

ASSEMBLING PISTON & CONNECTING ROD

- f. Check to make sure the connecting rod can be easily moved.

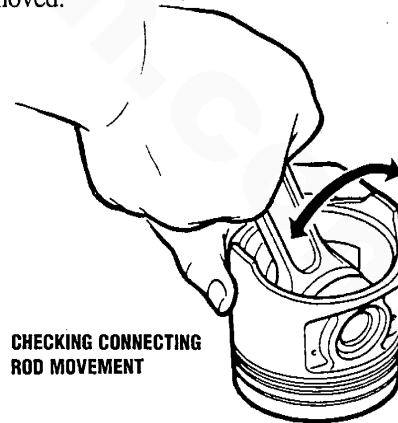

CHECKING CONNECTING ROD MOVEMENT

2. Assemble the piston rings.
 a. Assemble the piston rings to the piston using the piston ring inserting tool (commercially available). The order of assembly is: oil ring expander, oil ring, second ring and top ring.

ENGINE REASSEMBLY

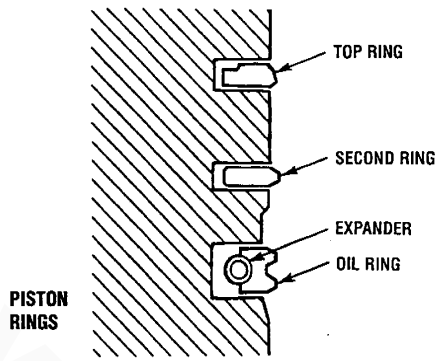

CAUTION:

- a) Apply engine oil liberally during installation.
- b) The rings must be mounted so the "N" mark faces upward.

- b. Align the piston ring openings as shown in the illustration.

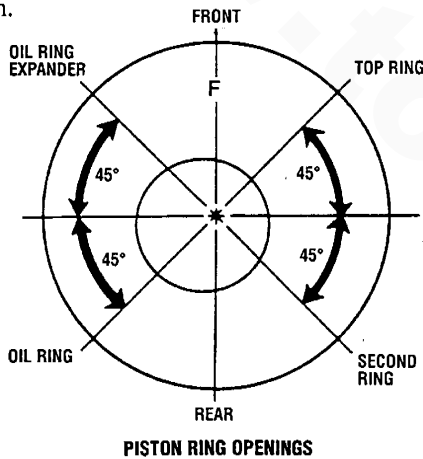

3. Install the pistons and connecting rods.
 - a. Fit the connecting rod bearing to the connecting rod and apply engine oil.
 - b. After cleaning the inner surface of the cylinder liner, apply engine oil.
 - c. Insert each piston and connecting rod assembly into the cylinder block using a piston insertion tool (commercially available).

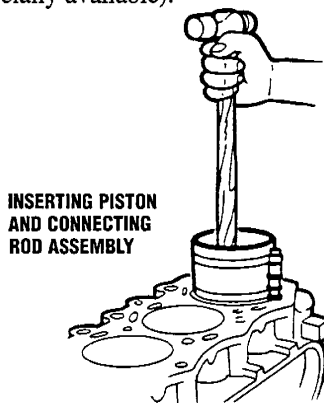

CAUTION:

- a) Pistons must be inserted so that the front marks (F) face front.
- b) Apply engine oil liberally to the cylinder liner walls, piston circumference and rings.
- c) Check to be sure that each oil jet aligns to the oil path in the piston at BDC. If not, replace the oil jet with a new one.

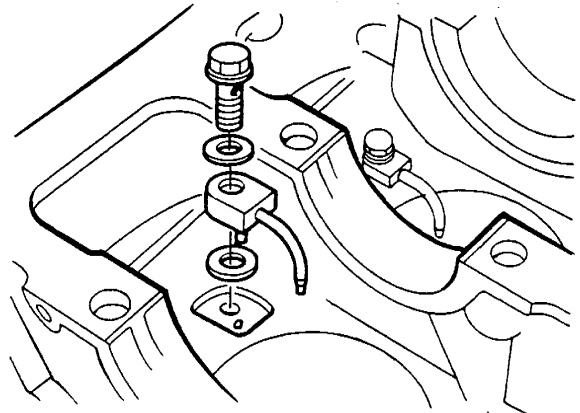

ALIGNING THE OIL JETS

4. Install each connecting rod bearing cap as follows:
 - a. Measure and adjust the connecting rod bearing and crankshaft pin journal oil clearance by the same procedure used to measure and adjust the crankshaft and main bearing oil clearance.

Connecting rod bearing cap tightening torque:
59 – 65 ft-lb (8.2 – 9.0 m-kg)

Standard oil clearance:
0.0014 – 0.0030 in (0.036 – 0.076 mm)

Oil clearance limit: 0.0020 in (0.05 mm)

Undersize connecting rod bearings:
0.010 in (0.254 mm), 0.020 in (0.508 mm),
0.030 in (0.762 mm)

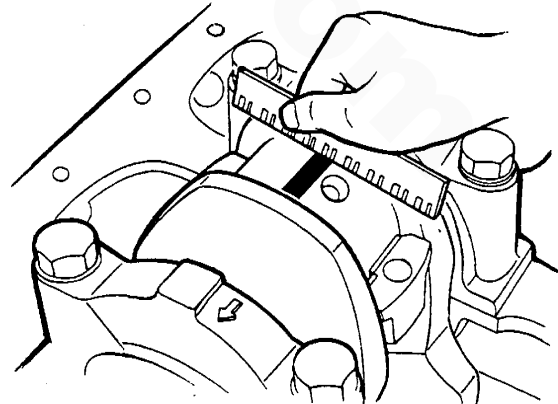

MEASURING CONNECTING ROD BEARING & CRANKSHAFT PIN JOURNAL OIL CLEARANCE



ENGINE REASSEMBLY

- b. Check the connecting rod end play.

Standard connecting rod end play:

0.0094 – 0.0130 in (0.239 – 0.379 mm)

End play limit: 0.0157 in (0.40 mm)

NOTE: Measure each connecting rod's end play before installing the connecting rod bearing cap.

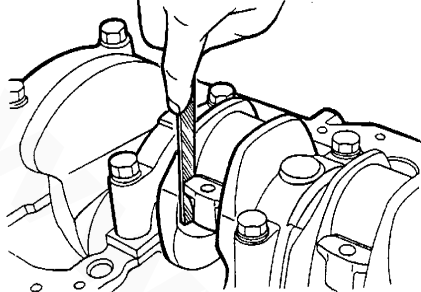

CHECKING CONNECTING ROD END PLAY

- c. Install the connecting rod bearing cap and tighten it to the specified torque. When doing so, apply engine oil to the threaded part of the bolts and nuts and to the bearing surfaces.

Connecting rod bearing cap tightening torque:

59 – 65 ft-lb (8.2 – 9.0 m-kg)

CAUTION: Install the connecting rod bearing cap after aligning the cap and connecting rod mating marks.

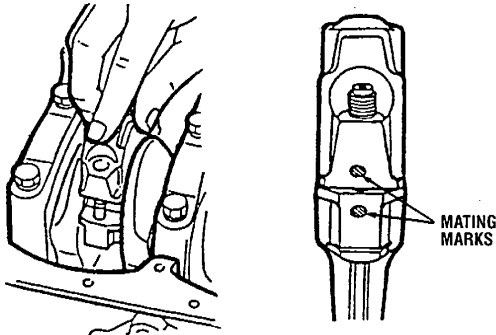

INSTALLING CONNECTING ROD BEARING CAP

Crankshaft Rear Oil Seal Flange

Install the crankshaft rear oil seal flange, with its gasket and oil seal.

NOTE: Apply engine oil to the oil seal before assembly.

Rear oil seal flange tightening torque:

14 – 19 ft-lb (1.9 – 2.6 m-kg)

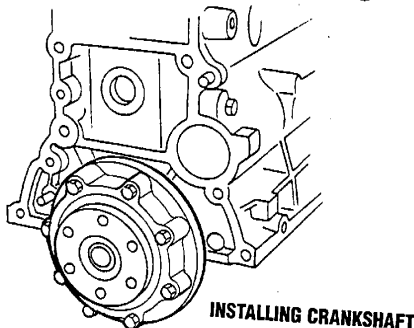

INSTALLING CRANKSHAFT

Back Plate

Install the back plate.

Back plate tightening torque:

28 – 38 ft-lb (3.8 – 5.3 m-kg)

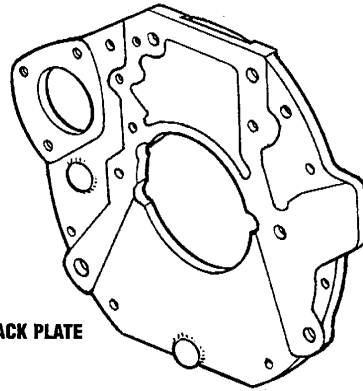

BACK PLATE

Flywheel and Flywheel Washer

1. Install the flywheel and flywheel washer. Temporarily tighten the bolts by hand.

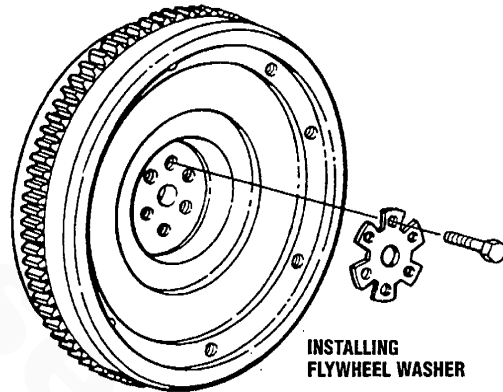

INSTALLING FLYWHEEL WASHER

2. Turn the flywheel until the first cylinder is at TDC.
3. Secure the flywheel with the ring gear brake (Mazda #49 V101 060A) and collar (Mazda #49 W065 062).
4. Tighten the bolts on the flywheel.

Flywheel tightening torque:

130 – 145 ft-lb (18 – 20 m-kg)

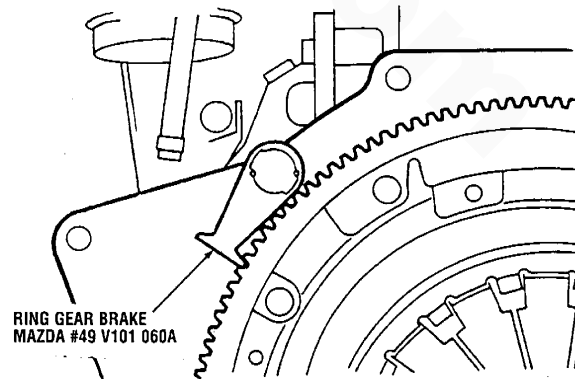

RING GEAR BRAKE
MAZDA #49 V101 060A

SECURING THE FLYWHEEL

WESTERBEKE
Engines & Generators

ENGINE REASSEMBLY

Timing Gear Case

1. Attach the idler gear hub making sure that the oil holes are aligned. Temporarily tighten the bolts.

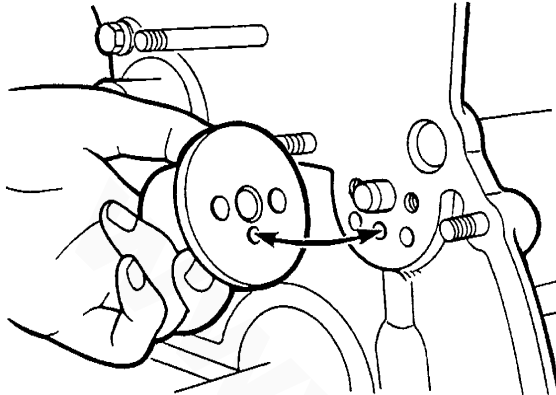

ATTACHING IDLER GEAR HUB

2. Install the timing gear case gasket.

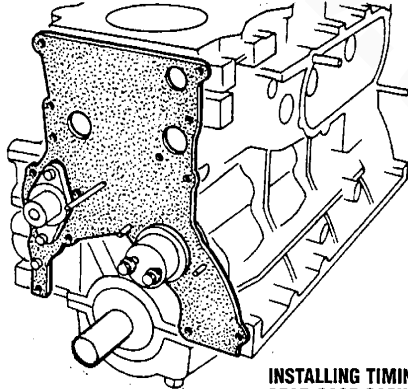

INSTALLING TIMING GEAR CASE GASKET

3. Install the timing gear case.

Timing gear case tightening torque:
14 - 19 ft-lb (1.9 - 2.6 m-kg)

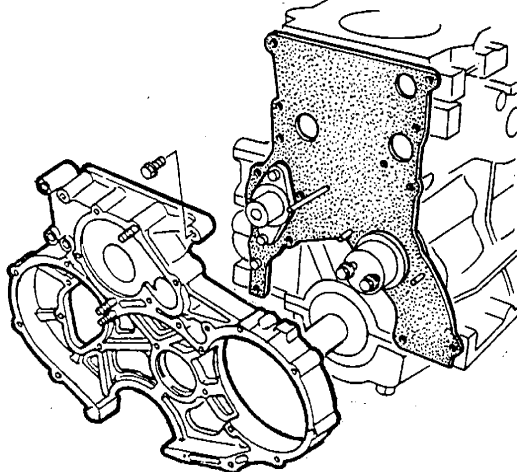

INSTALLING TIMING GEAR CASE

4. Trim off the protruding parts of the gasket between the cylinder block and the timing gear case.

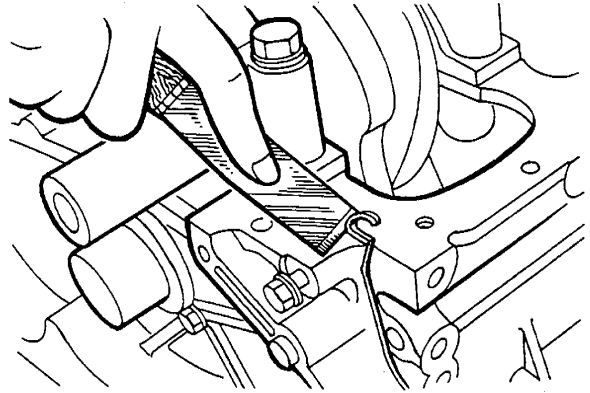

TRIMMING THE BLOCK TO TIMING GEAR CASE GASKET

5. Apply a silicon-based sealant to the areas where the gasket was trimmed off.

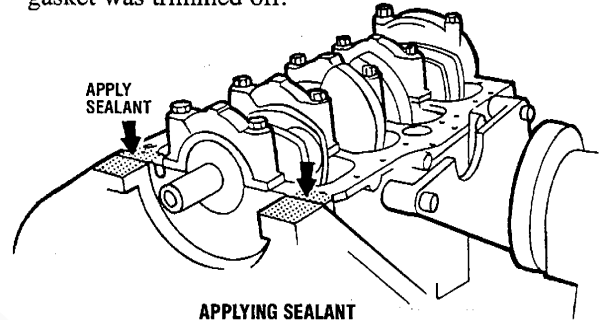

APPLYING SEALANT

Lower Block

1. Apply a silicon-based sealant to the ends of the block-to-lower-block front and rear gaskets, and install them. Apply the sealant to both ends of each gasket.

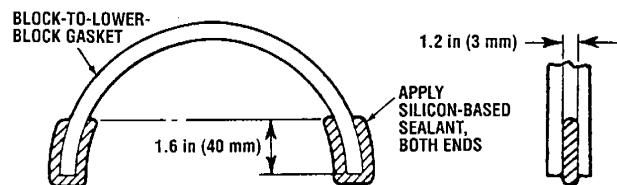
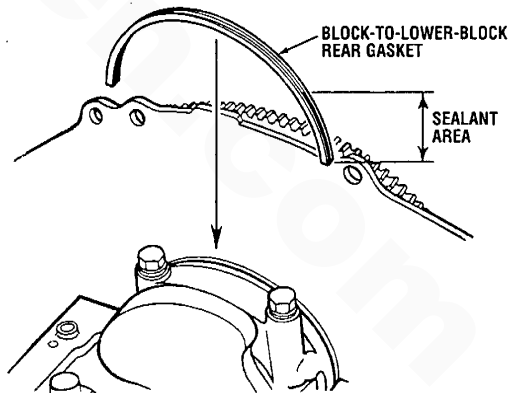

INSTALLING BLOCK-TO-LOWER-BLOCK GASKET (REAR GASKET SHOWN)

ENGINE REASSEMBLY

2. Install the right and left block-to-lower-block gaskets onto the cylinder block and then install the lower block.

Lower block tightening torque:
14 – 19 ft-lb (1.9 – 2.6 m-kg)

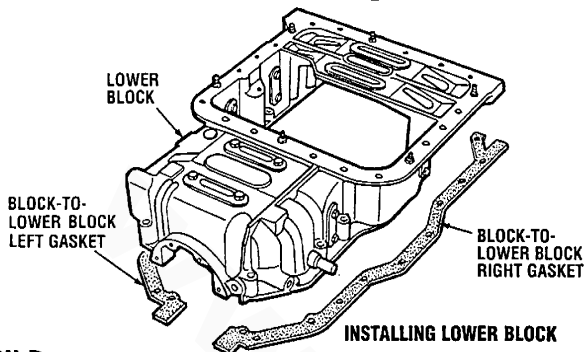

Oil Pump

Remove the oil pipe from the oil pump and install the oil pump. Re-install the oil pipe.

NOTE: Install the oil pipe after coating the O-ring with engine oil.

Oil pump tightening torque:
Large bolts: 14 – 19 ft-lb (1.9 – 2.6 m-kg)
Oil pipe tightening torque:
Small bolts: 5.8 – 8.0 ft-lb (0.8 – 1.1 m-kg)

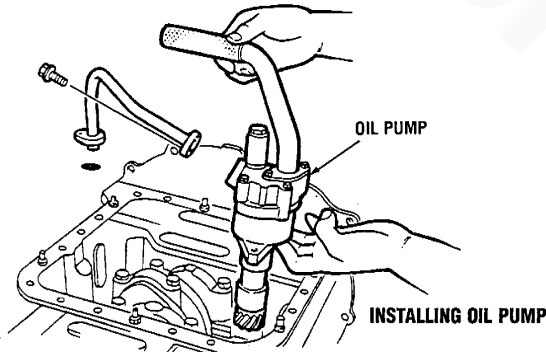

Oil Sump

Set the rubber gasket between the lower block and the oil sump, then set the sump stiffeners and install the sump.

Oil sump tightening torque:
14 – 19 ft-lb (1.9 – 2.6 m-kg)

CAUTION: Be sure the oil sump attaching bolts do not twist the gasket.

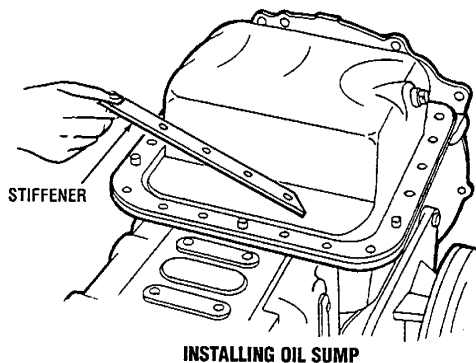

Oil Cooler

Install the lube oil cooler housing and gasket.

Oil Filter Housing

Install the oil filter housing, gasket and oil filter.

Oil filter housing tightening torque:
14 – 19 ft-lb (1.9 – 2.6 m-kg)

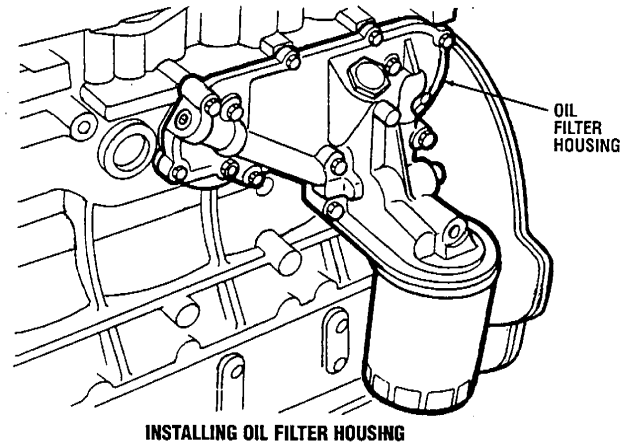

Timing Gears

1. Install the crankshaft gear and key.

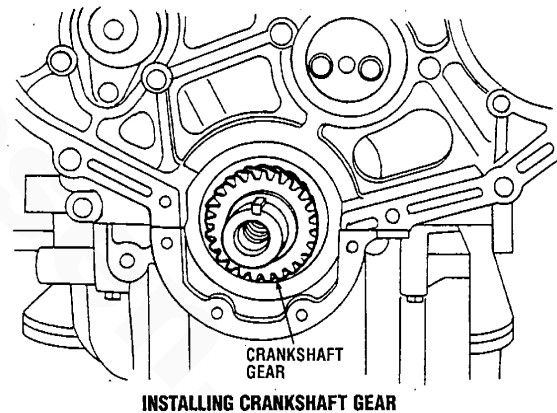

2. Remove the bolts on the idler gear hub and install the idler gear and idler gear plate making sure that the "A" marks are aligned. Tighten the bolts.

Idler gear tightening torque:
14 – 19 ft-lb (1.9 – 2.6 m-kg)

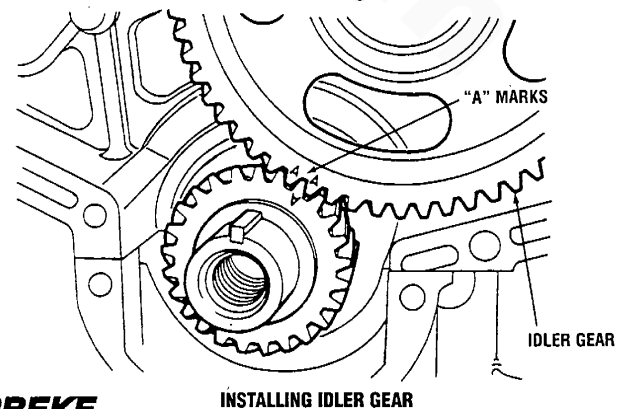

ENGINE REASSEMBLY

3. Install the camshaft gear and key, making sure that the "B" marks are aligned.

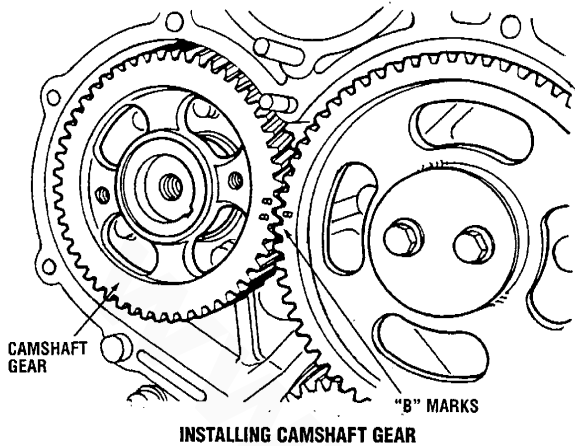

4. Install the camshaft friction gear and lock plate to the camshaft gear and tighten the bolt.

Friction gear tightening torque:
46 – 69 ft-lb (6.4 – 9.5 m-kg)

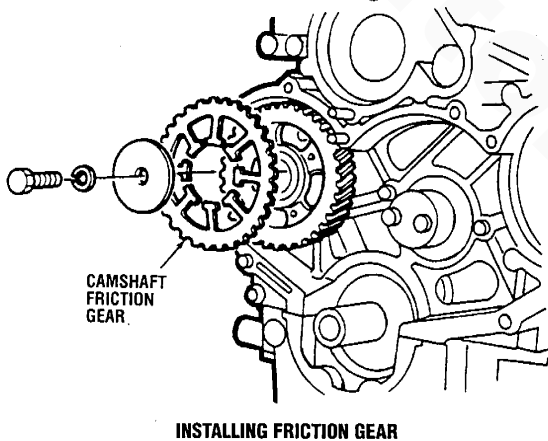

5. Fuel injection pump installation

- a. Install the fuel injection pump by first aligning the notch on the injection pump gear with the mark on the casing. Carefully insert the injection pump, making sure the gear has not turned. Check that the "C" marks are aligned. If not, remove the pump and try again.

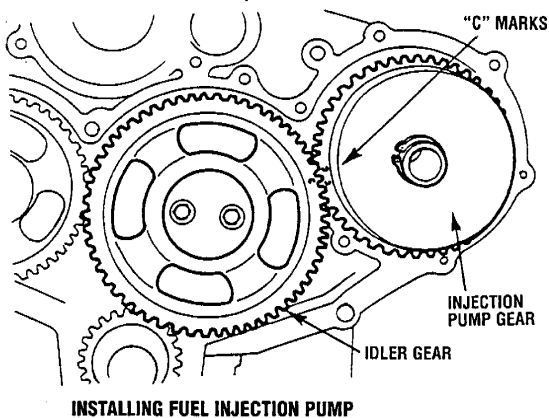

- b. Tighten the fuel injection pump bolts to the specified torques (see illustration).

Tightening torques:

A: 14 – 19 ft-lb (1.9 – 2.6 m-kg)

B: 27 – 38 ft-lb (3.8 – 5.3 m-kg)

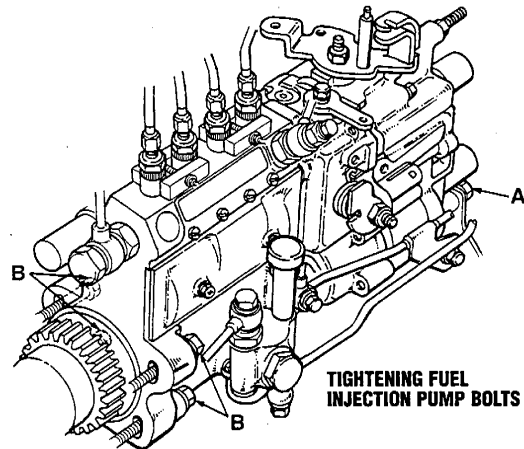

6. Install the crankshaft friction gear, friction gear spring and slinger to the crankshaft gear.

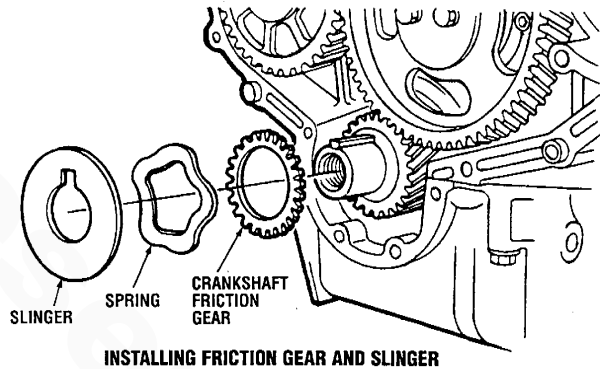

Timing Gear Cover

Install the timing gear cover and gasket.

Timing gear cover tightening torque:
14 – 19 ft-lb (1.9 – 2.6 m-kg)

NOTE: Apply engine oil to the lip of the oil seal before installation.

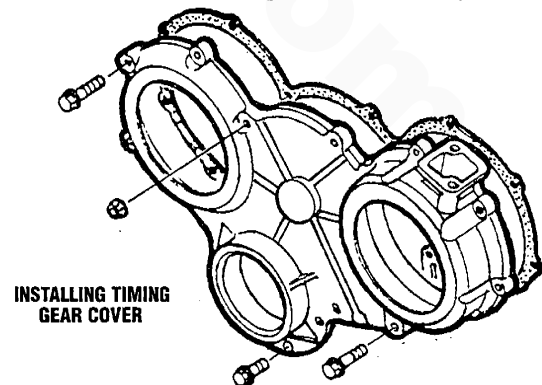

ENGINE REASSEMBLY

Crankshaft Pulley

Install the crankshaft pulley and tighten the bolts.

Crankshaft pulley tightening torque:
253 – 289 ft-lb (35 – 40 m-kg)

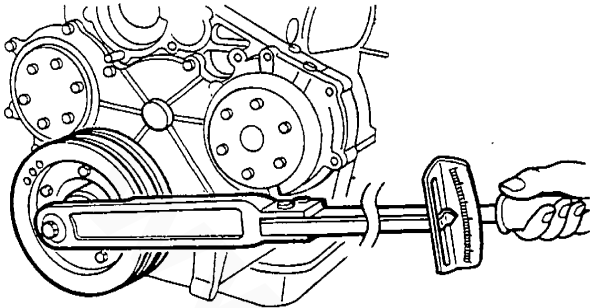

INSTALLING CRANKSHAFT PULLEY

Coolant Pump

Install the coolant pump and gasket.

Coolant pump tightening torque:
14 – 19 ft-lb (1.9 – 2.6 m-kg)

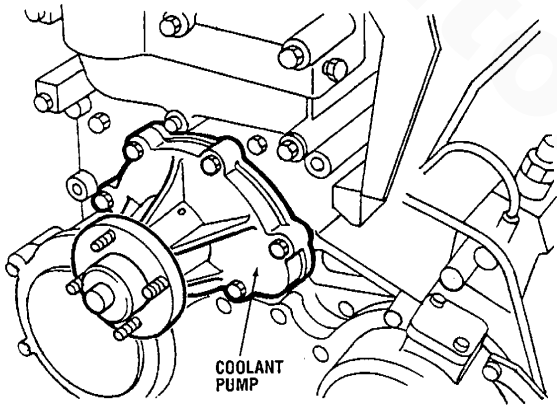

INSTALLING COOLANT PUMP

Alternator Bracket

Install the alternator bracket.

Alternator bracket tightening torque:
27 – 38 ft-lb (3.8 – 5.3 m-kg)

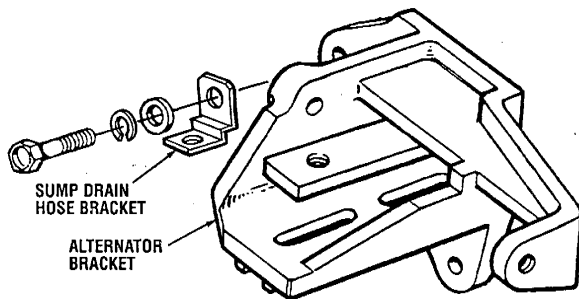

INSTALLING ALTERNATOR BRACKET

Cylinder Head

Install the cylinder head and gasket onto the cylinder block.

NOTE: Remove any dirt or grease from the top of the cylinder block and the bottom of the cylinder head.

CAUTION: Use a new cylinder head gasket.

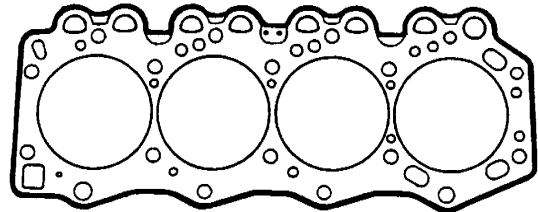

CYLINDER HEAD GASKET

Push Rods

Insert the push rods.

CAUTION: Make sure the ends of the push rods are set in the hollowed portion of the tappets.

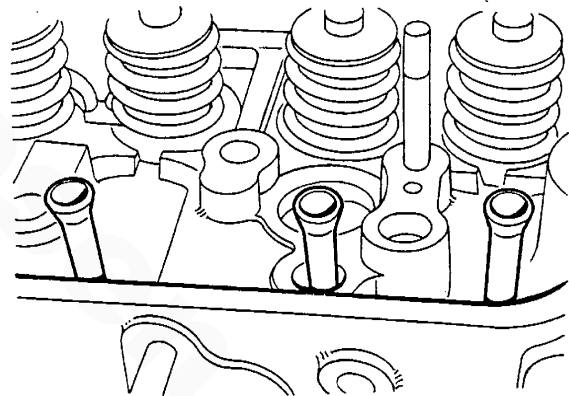

INSERTING PUSH RODS

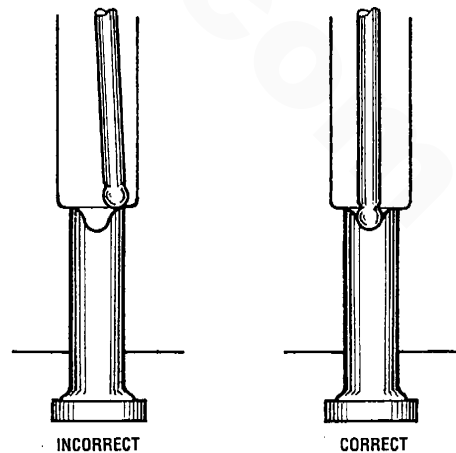

INCORRECT

CORRECT

INSERTING PUSH RODS

ENGINE REASSEMBLY

Valve Stem Caps

Apply engine oil to the valve stem caps and install them.

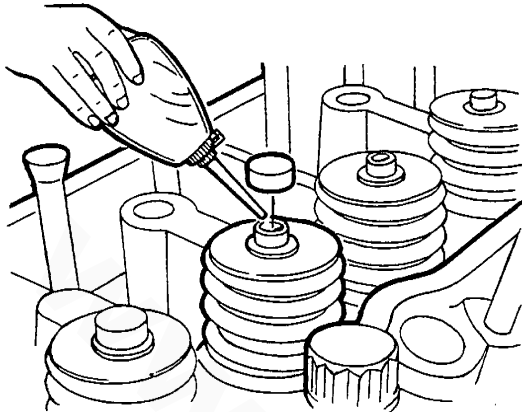

INSTALLING VALVE CAPS

Rocker Arm and Shaft Assembly

Reassemble the rocker arm and shaft assembly (if it was disassembled) and install it on the cylinder head. Tighten the two nuts to the specified torque.

Rocker arm tightening torque:
14 – 19 ft-lb (1.9 – 2.6 m-kg)

Note that the front end of the rocker shaft is identified by a pin protruding from the top and a larger oil hole between the supply holes serving #1 and #2 rocker arms. This pin fits a slot in the #1 rocker shaft support which prevents the shaft from turning and cutting off the lube oil to the rocker arms and valves.

Use the following order of assembly:

1. Spring
2. Rocker
3. Rocker shaft support
4. Rocker
5. Wave washer
6. Snap ring

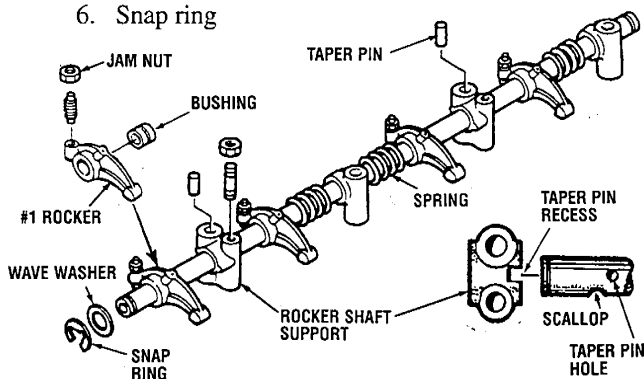

INSTALLING ROCKER ARM ASSEMBLY

Cylinder Head Bolts:

1. Measure the length of each cylinder head bolt from below the head. If the measured value is within the specified limit, apply engine oil to the threads and insert the bolt into its original location.

Length of the cylinder head bolt measured from below the head:

Standard:

Long size: 5.93 – 5.96 in (150.7 – 151.3 mm)

Short size: 4.79 – 4.82 in (121.7 – 122.3 mm)

Limit:

Long size: 5.98 in (152.0 mm)

Short size: 4.84 in (123.0 mm)

CAUTION: If the length of the bolt below the head exceeds the specified limit, it must be replaced.

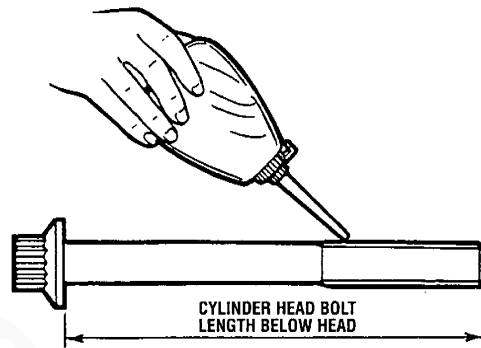

CYLINDER HEAD BOLTS

2. Tighten the cylinder head bolts to a tightening torque of 43 ft-lb (6.0 m-kg) in the sequence shown in the illustration.

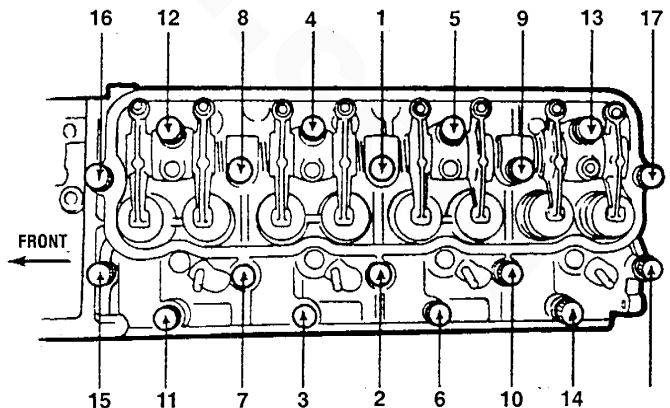

CYLINDER HEAD BOLTS TIGHTENING SEQUENCE



ENGINE REASSEMBLY

3. Mark the cylinder head bolts as shown in the illustration.

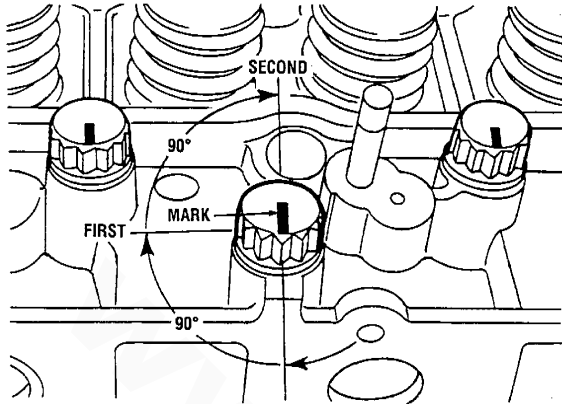

MARKING THE CYLINDER HEAD BOLTS

4. Using these marks as reference points, tighten the cylinder head bolts 90° (90° – 105°) in the same sequence.
5. *Once again* tighten them 90° (90° – 105°) in the same sequence.

CAUTION:

- a) *Be absolutely sure to tighten in the sequence shown in the illustration.*
- b) *Make sure the rocker arms and push rods are squarely engaged while tightening.*

Fuel Injectors

Install the fuel injectors, O-rings, gaskets, injector brackets and fuel return line.

NOTE: *Be sure the notch on the injector bracket is engaged in the hole in the cylinder head.*

Fuel injector tightening torque:
34 – 40 ft-lb (4.7 – 5.5 m-kg)

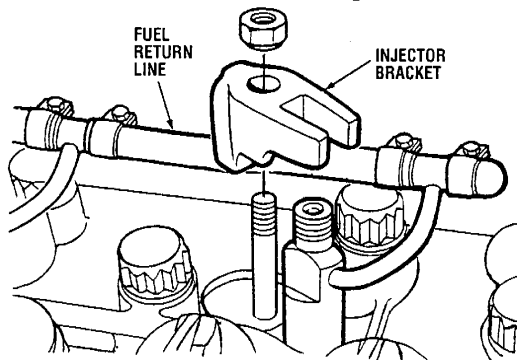

INSTALLING FUEL INJECTORS

Fuel Return Lines

Install the fuel injector's return lines.

Intake Manifold

Install the intake manifold and gasket.

Intake manifold tightening torque:
14 – 19 ft-lb (1.9 – 2.6 m-kg)

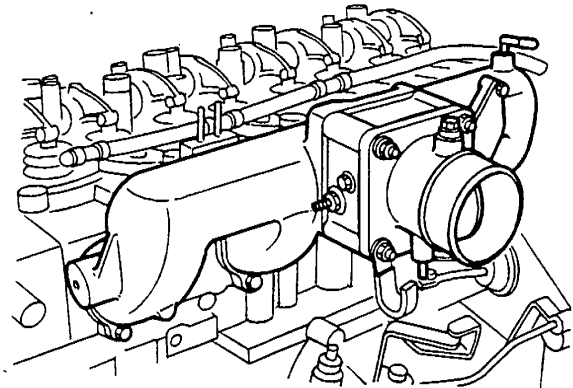

INSTALLING INTAKE MANIFOLD

Air Intake Silencer

Install the air intake silencer.

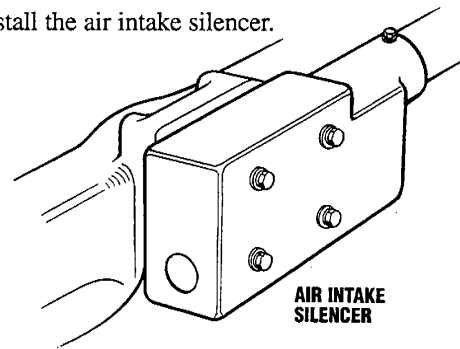

AIR INTAKE SILENCER

Lifting Eyes & Fuel Filter

1. Install both front lifting eyes.

Front lifting eye tightening torque:

Water pump side:

Small bolt: 14 – 19 ft-lb (1.9 – 2.6 m-kg)

Large bolt: 47 – 66 ft-lb (6.5 – 9.1 m-kg)

Alternator side:

27 – 38 ft-lb (3.8 – 5.3 m-kg)

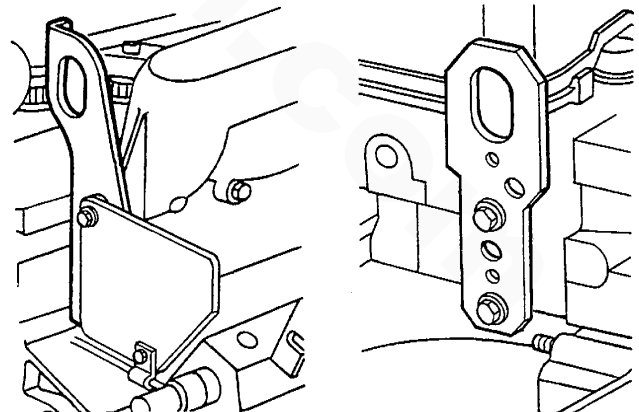

LEFT SIDE

RIGHT SIDE

INSTALLING FRONT LIFTING EYES



ENGINE REASSEMBLY

2. Install the rear lifting eye and the fuel filter assembly.

Rear lifting eye tightening torque:

Lifting eye bolt: 14 – 19 ft-lb (1.9 – 2.6 m-kg)
 Fuel filter bolts: 27 – 38 ft-lb (3.8 – 5.3 m-kg)

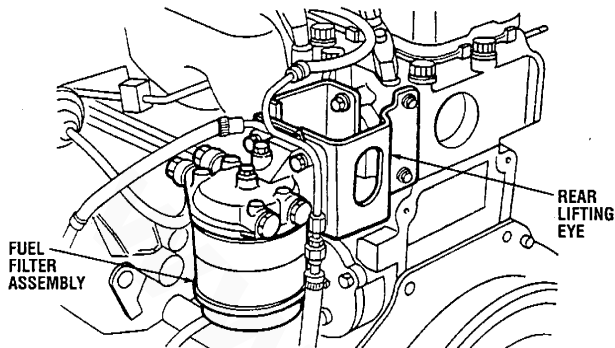

INSTALLING REAR LIFTING EYE & FUEL FILTER ASSEMBLY

Fuel Feed Line

1. Install the fuel feed line from the fuel lift pump to the engine-mounted fuel filter.

Fuel feed line tightening torque:

Joining bolts: 22 – 25 ft-lb (3.0 – 3.5 m-kg)
 Bracket bolts:
 Small: 5.8 – 8.0 ft-lb (0.8 – 1.1 m-kg)
 Large: 14 – 19 ft-lb (1.9 – 2.6 m-kg)

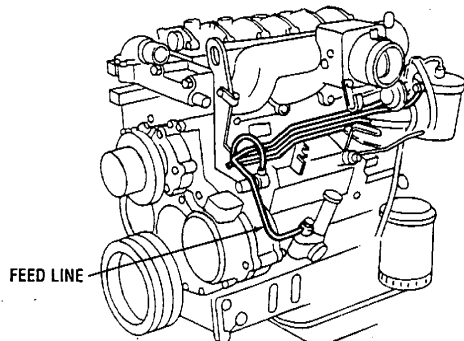

INSTALLING FUEL FEED LINE

2. Install the fuel line from the fuel filter to the injection pump.
3. Install the injection pump return line.
4. Install the fuel supply line to the fuel lift pump.

Fuel line tightening torque:

Joining bolt: 21.7 – 25.3 ft-lb (3.0 – 3.5 m-kg)
 Bracket bolt: 5.8 – 8.0 ft-lb (0.8 to 1.1 m-kg)

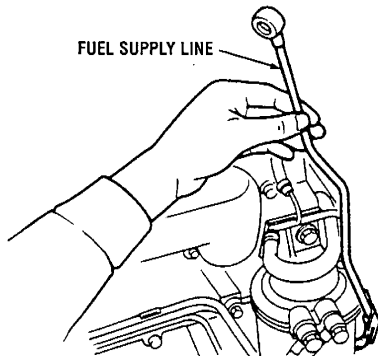

INSTALLING FUEL SUPPLY LINE TO FUEL LIFT PUMP

5. Install the fuel injection pump oil line.

Injection pump oil line tightening torque:

Joining bolts:
 A: 17 – 26 ft-lb (2.4 – 3.6 m-kg)
 B: 9 – 13 ft-lb (1.2 – 1.8 m-kg)

Bracket bolts:

C: 14 – 19 ft-lb (1.9 – 2.6 m-kg)
 D: 5.9 – 8.0 ft-lb (0.8 – 1.1 m-kg)

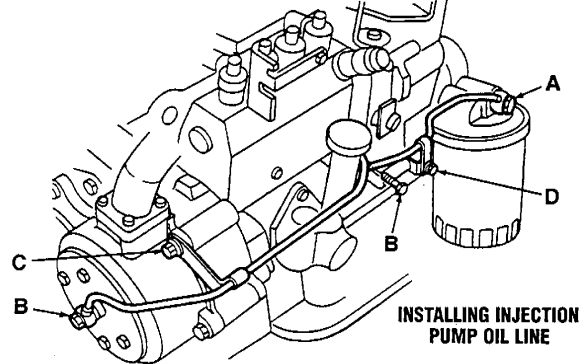

INSTALLING INJECTION PUMP OIL LINE

6. Install the fuel injection lines, and their clamps, from the injection pump to the injectors.

CAUTION: Be careful not to damage the fuel injection lines when installing them.

Injection line tightening torque:

Joining nuts: 18 – 22 ft-lb (2.5 – 3.0 m-kg)

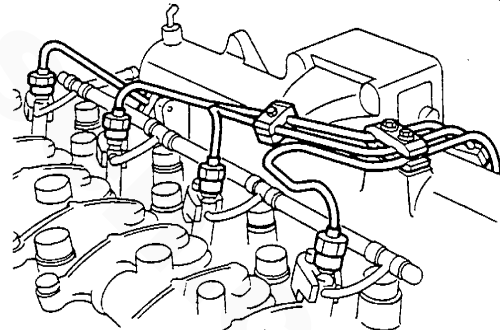

INSTALLING FUEL INJECTION LINES

Oil Level Dipstick

1. Install the oil level dipstick.

Oil level dipstick tightening torque:
 14 – 19 ft-lb (1.9 – 2.6 m-kg)

NOTE: Apply engine oil to the O-ring before installation.

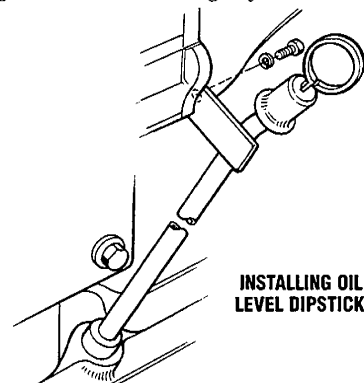

INSTALLING OIL LEVEL DIPSTICK



ENGINE REASSEMBLY

Raw Water Pump

Install the raw water pump and drive belt. Make sure the raw water pump's pulley is in proper alignment with the crankshaft pulley. Check the belt tension. See the *RAW WATER PUMP* page for pump servicing information.

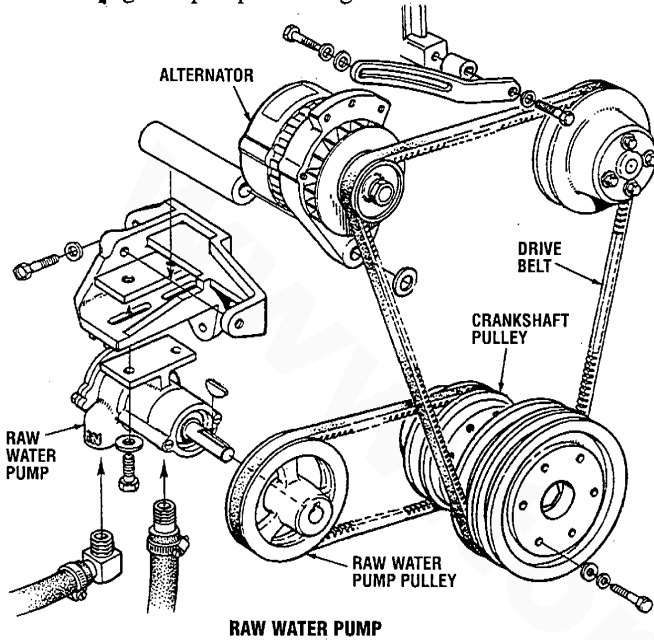

1. Install the alternator cap screw through the alternator leg (underside) and spacer into the alternator bracket.
2. Swing the alternator into position on the adjusting strap and fasten. Lightly tighten.
3. Install the drive belt and adjust the belt tension.
4. Tighten both bolts and recheck the belt tension.

NOTE: Make certain the belts are perfectly aligned with the alternator and engine pulleys. If not, insert or remove spacers as needed, to align the alternator.

See *ALTERNATOR TROUBLESHOOTING* for testing information.

Alternator strap tightening torque:
14 – 19 ft-lb (1.9 – 2.6 m-kg)

Alternator tightening torque:
Strap bolt: 14 – 19 ft-lb (1.9 – 2.6 m-kg)
Long bolt and nut:
27 – 38 ft-lb (3.8 – 5.3 m-kg)

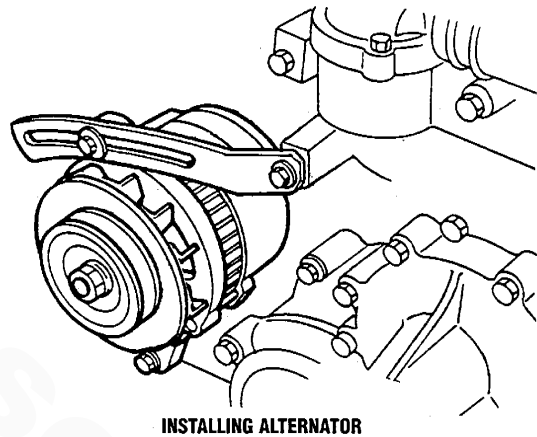

Coolant Pump Connector and Hose

Install the coolant pump connector and the hose to the heat exchanger.

Coolant pump connector tightening torque:
14 – 19 ft-lb (1.9 – 2.6 m-kg)

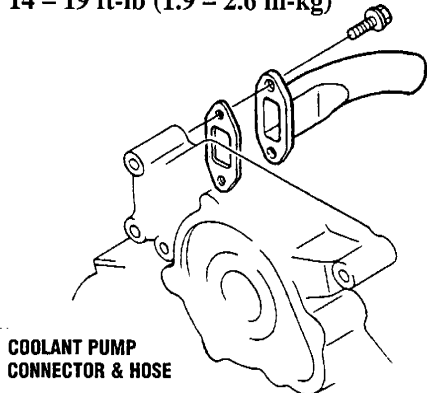

Thermostat

If the thermostat was removed, reinstall the thermostat, gasket and housing.

Thermostat tightening torque:
5.8 – 8.0 ft-lb (0.8 – 1.1 m-kg)

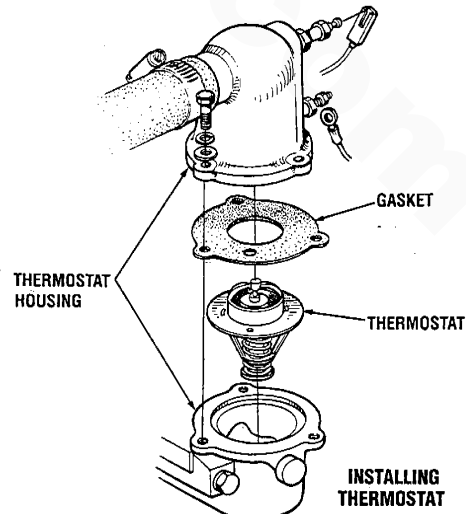

Alternator

Install the alternator, alternator adjusting strap and drive belt as follows.

CAUTION: Connect the alternator properly. Should the polarity be reversed, a powerful current would flow from the battery into the alternator, damaging the diodes and wiring harness.

ENGINE REASSEMBLY

Rocker Cover and Crankcase Breather Hose

1. Apply *Three Bond (1382)* to the rocker cover gasket at the locations shown in the illustration.
2. Install the rocker cover and its gasket.
3. Install the crankcase breather hose.

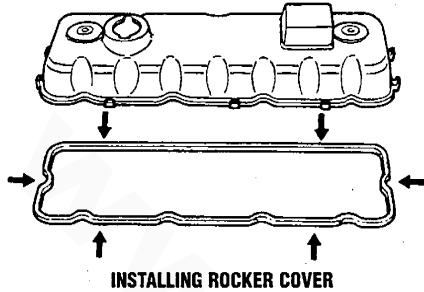

4. Put the rocker cover outer gasket on the rocker cover's cover and install.

Rocker cover's cover tightening torque:
1.4 – 2.5 ft-lb (0.2 – 0.35 m-kg)

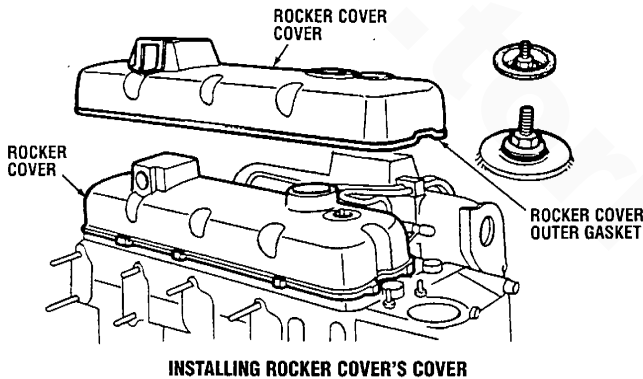

Exhaust Manifold

Install the exhaust manifold (see *EXHAUST MANIFOLD* page).

Exhaust manifold tightening torque:
17 – 20 ft-lb (2.3 – 2.7 m-kg)

CAUTION: Retighten the exhaust manifold using the same torque after idling for twenty minutes.

Back Plate

Attach the back plate.

Back plate tightening torque (9/16" socket):
27 – 38 ft-lb (3.8 – 5.3 m-kg)

Fuel filter Assembly

Mount the fuel filter assembly.

Fuel filter tightening torque:
33 – 49 ft-lb (4.6 – 6.8 m-kg)

Transmission Damper Plate (propulsion engines only)

Install the transmission damper plate.

Damper plate tightening torque:
14 – 20 ft-lb (1.7 – 2.7 m-kg)



Bellhousing (propulsion engines only)

Install the bellhousing.

Heat Exchanger

Mount the engine heat exchanger. The heat exchanger should be serviced when the engine is overhauled (see *HEAT EXCHANGER* under *COOLING SYSTEM* for inspection and servicing information). Install the hose connector elbow and the hose from the coolant pump.

Starter Motor

Install the starter motor.

Oil Pressure Switch and Oil Pressure Sender

Install the oil pressure switch and sender.

Oil pressure switch and sender tightening torque:
9 – 13 ft-lb (1.2 – 1.8 m-kg).

Engine Wiring Harness

Assemble the engine wiring harness and ground wires. Reconnect all DC wiring harness terminals to their engine components.

CAUTION: Check all AC and DC wiring connections by referring to the *WESTERBEKE* wiring diagrams and schematics.

PROPULSION ENGINES

1. Assemble the damper plate to the flywheel.

Damper plate tightening torque:
14 – 20 ft-lb (1.7 – 2.7 m-kg)

2. Reinstall the marine transmission and fill with the proper lubricant.

NOTE: Some transmissions, such as the Borg Warner Velvet Drive, require oil coolers. Oil coolers should be cleaned, pressure tested and repainted at engine overhaul. The transmission oil cooler hoses should also be inspected. Refer to the text on Heat Exchangers.

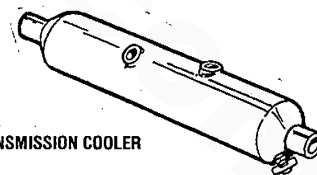

TRANSMISSION COOLER

3. Fill the engine cooling system with pre-mixed coolant (50/50 good quality antifreeze and distilled water). Fill the engine oil sump to the mark on the dipstick with lube oil (A.P.I. spec. CF or CG-4).

The engine should be test run under load prior to re-installing. At this time readjust the valve clearances on the hot engine.

Allow the engine to cool to room temperature and re-torque the cylinder head bolts and re-check the valve clearances (see *ENGINE ADJUSTMENTS*).

ENGINE REASSEMBLY

GENERATORS

1. Mount the generator back end assembly with its control panel. Reconnect all DC wiring and reconnect all AC connections.

CAUTION: Check all AC and DC wiring connections by referring to the WESTERBEKE wiring diagrams and schematics.

2. Fill the engine cooling system with pre-mixed coolant (50/50 good quality antifreeze and distilled water). Fill the engine oil sump to the mark on the dipstick with lube oil (A.P.I. spec. CF or CG-4).

The engine should be test run under load prior to re-installing. At this time readjust the valve clearances on the hot engine.

Allow the engine to cool to room temperature, then re-torque the cylinder head bolts and re-check the valve clearances (see *ENGINE ADJUSTMENTS*).

EXHAUST MANIFOLD

See the *EXHAUST MANIFOLD* page for inspection and assembly information.

EXHAUST MANIFOLD

INSPECTION

The exhaust manifold, which was disassembled from the cylinder head, should be inspected before reassembly.

1. Remove the exhaust nipples, elbows and plugs from the manifold.
2. Examine all parts for defects, corrosion and wear, and replace as needed.
3. Flush out the manifold's interior with a liquid cleaner and rinse thoroughly with fresh water.
4. Use a pipe cleaner to clear the passage that connects the filler neck to the coolant recovery tank tubing.
5. Flush out the coolant recovery tank and its connecting tube.

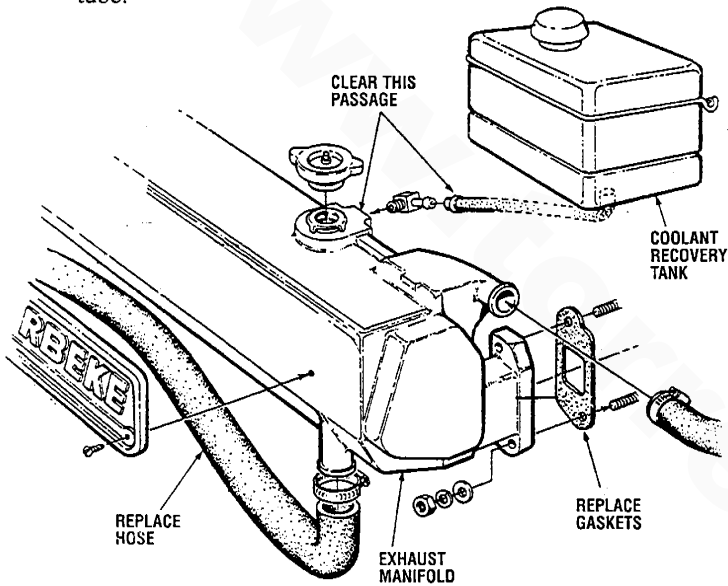

ASSEMBLY

1. If the manifold was removed as an assembly and left intact, it can be replaced on the cylinder head in the reverse order of removal.
Do not reuse the gaskets; install new ones.
 - a. Loosely attach the manifold elbows to the cylinder head using new gaskets. Do not use any gasket sealant on these gaskets.
 - b. Gradually tighten each fitting to ensure proper alignment of all the parts. This should be done in three steps.

Manifold mounting bolts torque:
12 – 17 ft-lb (1.6 – 2.4 m-kg)

2. Reinstall the exhaust connections. Use new gaskets and check the exhaust elbow-to-manifold clamp's condition. Replace it if necessary.
3. Check the manifold pressure cap. Open the valve by pulling it, and make sure it closes when released. Make certain the upper and lower seals are in good condition. If any doubt, replace the cap.

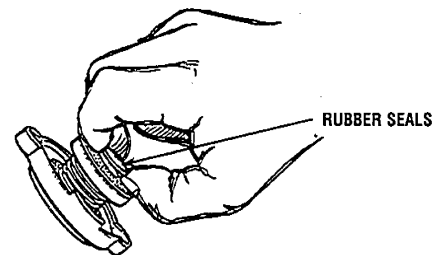

CHECKING THE PRESSURE CAP

ENGINE ADJUSTMENTS

NOTE: WESTERBEKE recommends that the following engine adjustments be performed by a competent engine mechanic. The information below is provided to assist the mechanic.

VALVE CLEARANCE ADJUSTMENT

1. Remove the cylinder head cover.
2. Set the piston of No. 1 cylinder to the Top Dead Center (TDC) of its compression stroke.
3. Check the valve clearances only for the valves shown below. Adjust these valves if their clearances deviate from the specified values.

Intake: No. 1 and No. 2 cylinders

Exhaust: No. 1 and No. 3 cylinders

Valve clearance (engine cold):

Intake: 0.012 in (0.30 mm)

Exhaust: 0.014 in (0.35 mm)

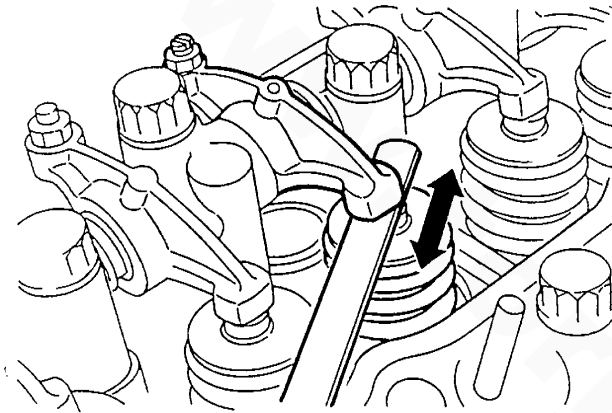

CHECKING THE VALVE CLEARANCE

CAUTION: Do NOT retorque the cylinder head bolts. They are stretch bolts and do not require retorquing.

4. Turn the crankshaft one turn so that the piston of No. 4 cylinder is at the TDC of its compression stroke. Check the valve clearance of the remaining valves as illustrated and adjust them if necessary.

Intake: No. 3 and No. 4 cylinders

Exhaust: No. 2 and No. 4 cylinders

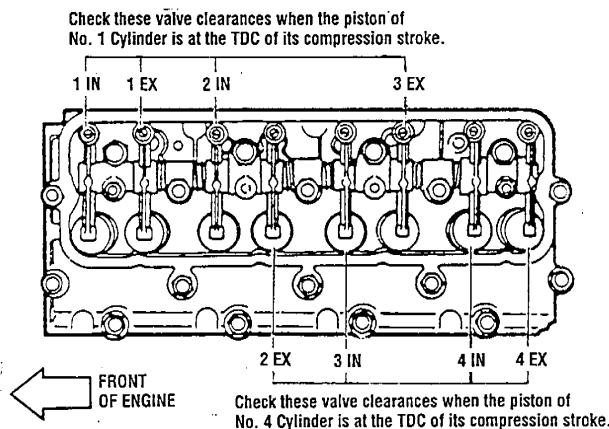

DRIVE BELT ADJUSTMENT

Proper inspection, service and maintenance of the drive belts is important for the efficient operation of your engine (see *Drive Belts* under *MAINTENANCE SCHEDULE*).

Drive belts must be properly tensioned. Loose drive belts will not provide proper alternator charging and will eventually damage the alternator. Drive belts that are too tight will pull the alternator out of alignment and/or cause the alternator to wear out prematurely. Excessive drive belt tension can also cause rapid wear of the belt and reduce the service life of the coolant pump's bearing. A slack belt or the presence of oil on the belt can cause belt slipping, resulting in high operating temperatures and tachometer variations.

The drive belt is properly adjusted if the belt can be deflected no less than 3/8 inch (10mm) and no more than 1/2 inch (12mm) as the belt is depressed with the thumb at the mid-point between the two pulleys on the longest span of the belt. A spare belt or belts should always be carried on board.

WARNING: Never attempt to check or adjust the drive belt's tension while the engine is in operation.

Adjusting Belt Tension

1. Loosen the alternator adjusting strap bolt and the base mounting bolt.
2. With the belt loose, inspect for wear, cracks and frayed edges.
3. Pivot the alternator on the base mounting bolt to the left or right as required, to loosen or tighten.
4. Tighten the base mounting bolt and the adjusting strap bolt.
5. Run the engine for about 5 minutes, then shut down and recheck the belt tensions.

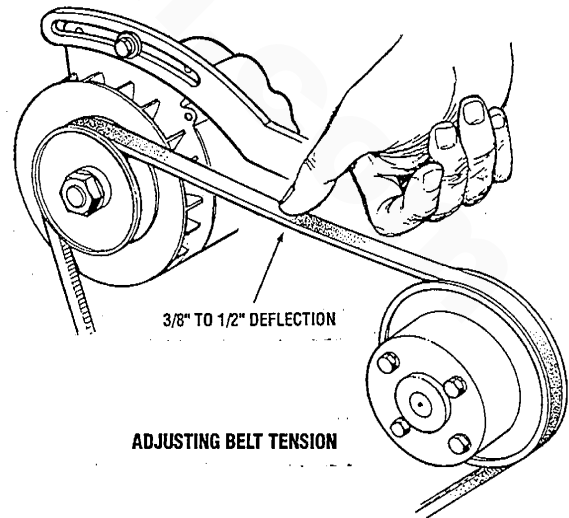

ADJUSTING BELT TENSION

5. Install the cylinder head cover.



ENGINE ADJUSTMENTS

NOTE: WESTERBEKE recommends that the following engine adjustments be performed by a competent engine mechanic. The information below is provided to assist the mechanic.

TORQUING THE CYLINDER HEAD BOLTS

CAUTION: Do NOT retorque the cylinder head bolts. They are stretch bolts, and do not require retorquing.

ENGINE COMPRESSION TEST

To check the engine's compression pressure, warm up the engine, shut off the raw water through-hull, remove all the fuel injectors, disconnect the fuel shut-off solenoid wire, and install a compression adapter in the injector hole. Connect a compression tester on the adapter and crank the engine with the starter motor until the pressure reaches a maximum value. Repeat this process for each cylinder. Look for cylinders with dramatically (at least 20%) lower compression than the average of the others.

Compression pressure:

Standard: 426 lb/in² (30 kg/cm²) @ 290 rpm

Limit: 384 lb/in² (27 kg/cm²) @ 290 rpm

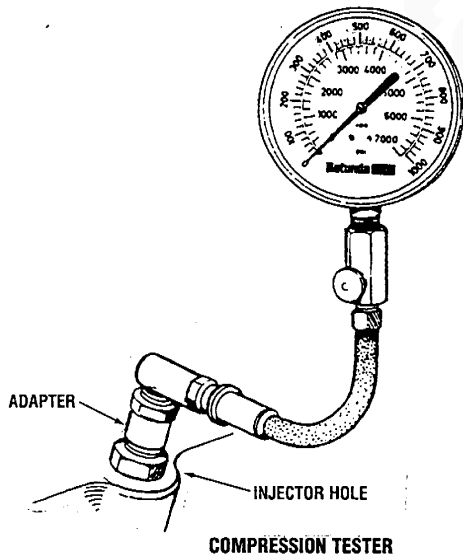

If a weak cylinder is flanked by healthy cylinders, the problem is either valve- or piston-related. Check the valve clearances for the weak cylinder, adjust as needed, and test again. If the cylinder is still low, apply a small amount of oil into the cylinder to seal the rings, and repeat the test. If the compression comes up, the rings are faulty.

Abnormally high readings on all cylinders indicate heavy carbon accumulation, a condition that might be accompanied by high pressures and noise.

NOTE: In case of severe vibrations and detonation noise, have the injectors checked and overhauled by an authorized fuel injection service center. Poor fuel quality, contaminants and loss of positive fuel pressure to the injection pump will result in injector faults.

IDLE SPEED ADJUSTMENT & TACHOMETER CHECK (New Installation)

Checking the Idle Speed

Use a photoelectric-type tachometer to check the idle speed.

NOTE: In a new installation having new instrument panels, the tachometer may not always be correctly calibrated to the engine's rpm. This calibration should be checked in all new installations.

1. Warm up the engine to normal operating temperature. Remove any specks on the crankshaft pulley with a clean cloth and place a piece of suitable reflecting tape on the pulley to facilitate the use of the tachometer.
2. Start and idle the engine.
3. Aim the light of the tachometer onto the reflecting tape to confirm the engine speed. Check the instrument panel tachometer reading. Adjust the tachometer in the panel by using the instrument calibration pod as needed to bring the instrument panel tachometer into the same rpm reading as the engine.
4. Adjust the idle speed if the engine speed is not within the specified value.

Normal idle speed: 700 – 900 rpm

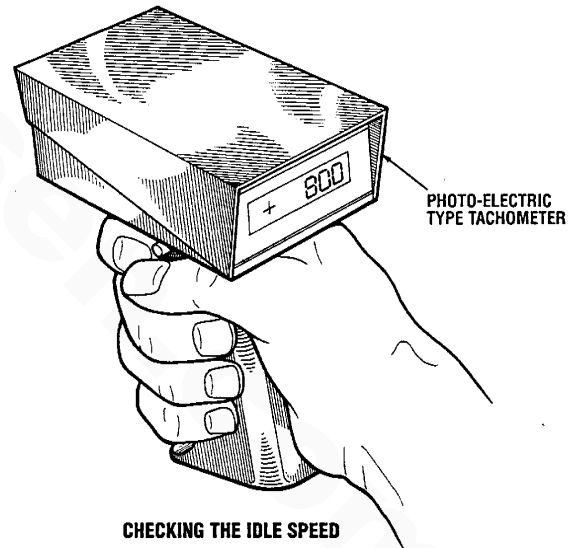

ENGINE ADJUSTMENTS

NOTE: WESTERBEKE recommends that the following engine adjustments be performed by a competent engine mechanic. The information below is provided to assist the mechanic.

Adjusting the Idle Speed

1. Loosen the locknut on the idle adjustment bolt on the fuel injection pump.
2. Turn the idle adjustment bolt until the idling speed is within the standard range. The idle speed will increase when the adjusting bolt is turned clockwise and decrease when turned counterclockwise.
3. Tighten the locknut.
4. Race the engine several times to ensure the idle speed remains as set.

NOTE: Should the engine rpm be in question, verify the tachometer readings as shown at the instrument panel with a mechanical or strobe-type tachometer at the engine crankshaft.

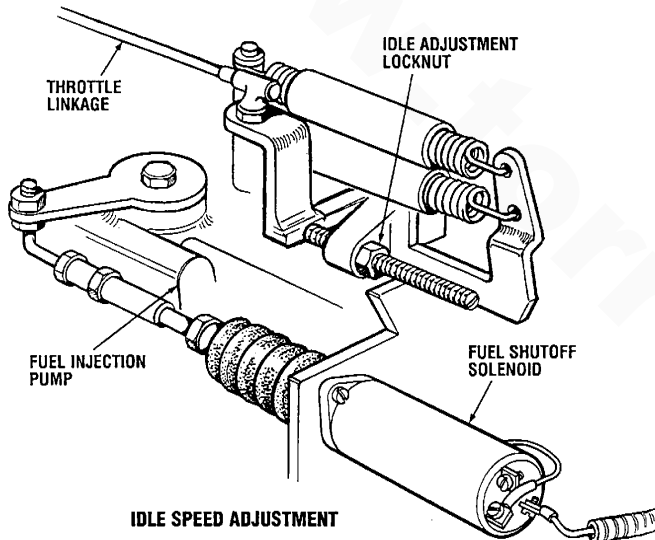

LUBRICATION SYSTEM

DESCRIPTION

The lubricating system is a pressure feeding system using an oil pump. The engine oil is drawn from the oil sump by the oil pump, which drives the oil, under pressure, through the oil filter, oil cooler and various lubricating points in the engine. The oil then returns to the oil sump to repeat the continuous cycle. When the oil pressure exceeds the specified pressure, the oil pushes open the relief valve in the oil pump and returns to the oil sump, keeping the oil pressure within its specified range.

TESTING THE OIL PRESSURE

To test the oil pressure, remove the oil pressure sender, then install a mechanical oil pressure gauge in its place. After warming up the engine, set the engine speed at 1800 rpm (generators) or 3600 rpm (propulsion engines) and read the oil pressure gauge. If the pressure is not within the specified range, check each part and repair if necessary.

Oil pressure:

30 – 35 lb/in² (2.1 – 2.5 kg/cm²) at 1800 rpm

50 – 55 lb/in² (3.5 – 3.9 kg/cm²) at 3600 rpm

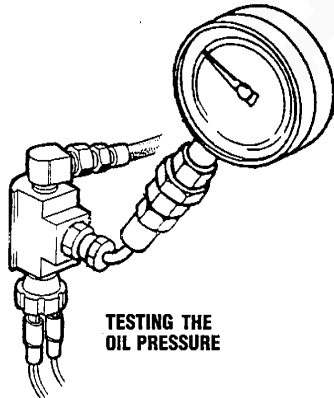

TESTING THE OIL PRESSURE

Low Oil Pressure

The specified safe minimum oil pressure is 4.3–1.4 psi (0.3–0.1 kg/cm²). A gradual loss of oil pressure usually indicates worn bearings. For additional information on low oil pressure readings, see the *ENGINE TROUBLESHOOTING* section.

OIL PRESSURE SWITCH/SENDER

When performing an engine overhaul, replace the oil pressure switch and the oil pressure sender.

When installing the new parts, apply teflon sealant to the threaded ends, being careful not to close off the oil hole in the sender.

Oil pressure switch and sender torque:

9 – 13 ft-lb (1.2 – 1.8 m-kg)

CAUTION: Oil Pressure Switch – Do not use lock pliers, vise grips or pipe wrenches on the oil pressure switch. Use the correct socket which is available from Snap-On, Proto, New Britain and others. Damage to the switch will cause oil leaks and/or switch failure.

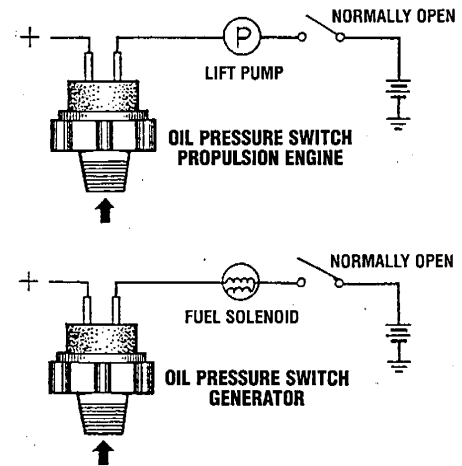

OIL PUMP

Removing the Oil Pump

Remove the following components from the engine in the numbered sequence (see illustration):

1. Stiffeners
2. Oil pan
3. Oil pan gasket
4. Oil pipe attaching bolts.
5. Oil pipe.
6. Oil pump

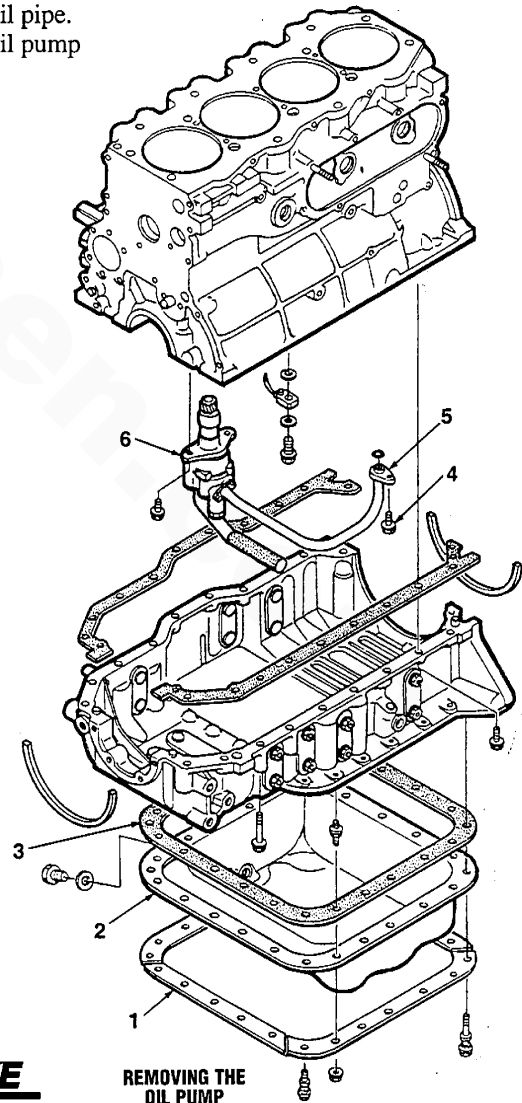

LUBRICATION SYSTEM

Disassembly

Disassemble the oil pump components in the following numbered sequence (see illustration).

1. Oil strainer
2. Oil strainer gasket
3. Pump cover
4. Outer rotor
5. Drive gear (use a press and a suitable mandrel)
6. Pump body
7. Inner rotor
8. Screw
9. Relief valve spring
10. Relief valve plunger

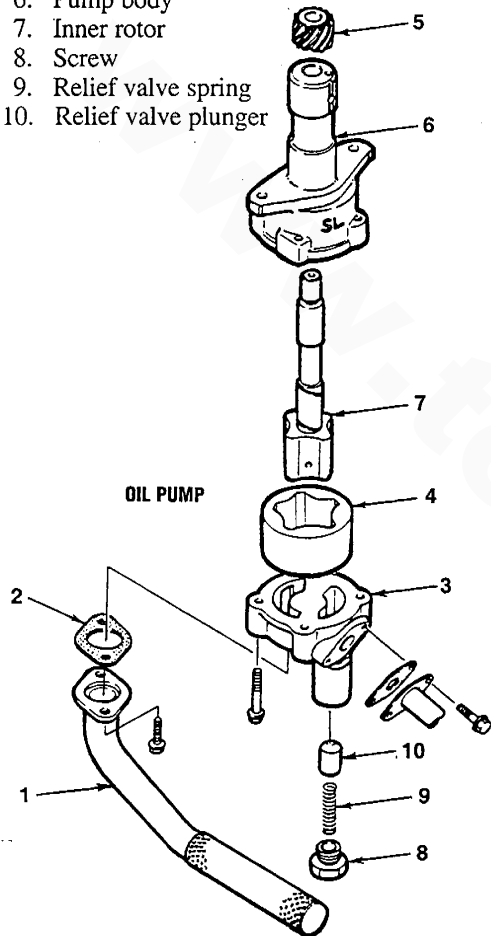

Inspection

1. Visually check the disassembled parts and replace any faulty parts.
 - a. Check the pump body and pump cover for distortion or damage. Repair or replace if necessary. Check the sliding surface of the pump cover with special care and replace the cover if the surface has steps or excessive streaks. Minor steps or streaks may be repaired by rubbing them with compound on a surface plate.

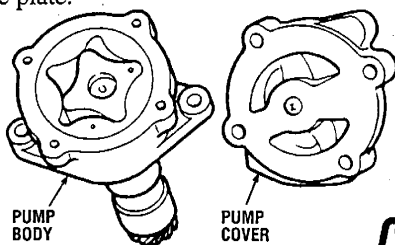

- b. Check the relief valve for wear or damage.
- c. Check for a weak or broken relief valve spring. Measure the spring's free length.

Standard relief valve spring free length:
1.69 – 1.76 in (42.8 – 44.8 mm)

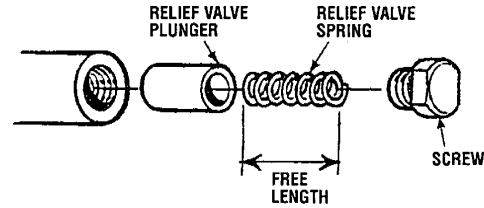

2. Inspect the clearance between the pump body and the shaft. Measure the clearance with a dial gauge and magnet base. If the clearance exceeds the limit, replace the pump drive shaft inner rotor, pump body and drive gear.

Standard clearance:
0.0015 – 0.0030 in (0.04 – 0.08 mm)
Clearance limit: 0.0039 in (0.10 mm)

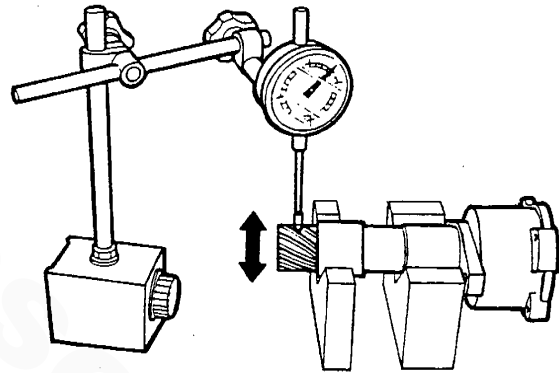

3. Inspect the clearance between the inner rotor and the outer rotor. Check the clearance between the lobes of the rotors with a feeler gauge. If the clearance exceeds the limit, replace both rotors.

Standard clearance:
0.0016 – 0.0079 in (0.04 – 0.20 mm)
Clearance limit: 0.0098 in (0.25 mm)

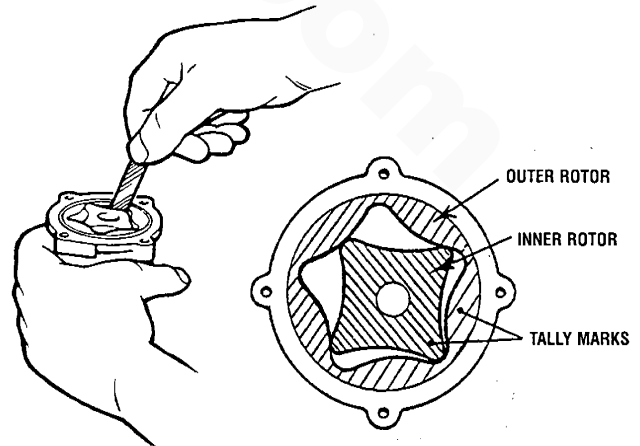

LUBRICATION SYSTEM

4. **Inspect the clearance between the outer rotor and the pump body.** Check the clearance between the outer rotor and the pump body with a feeler gauge. If the clearance exceeds the limit, replace the rotor or pump body.

Standard clearance:

0.0039 – 0.0083 in (0.10 – 0.21 mm)

Clearance limit: 0.0098 in (0.25 mm)

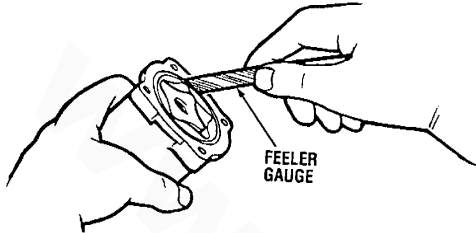

5. **Check the clearance between the rotors and the pump cover.** Inspect the end float of the rotors. Place a straightedge across the pump body and measure the clearance between the rotor and the straightedge with a feeler gauge. If the clearance exceeds the limit, replace the drive gear, drive shaft, inner rotor, outer rotor and pump body.

Standard clearance:

0.0012 – 0.0039 in (0.03 – 0.10 mm)

Clearance limit: 0.0059 in (0.15 mm)

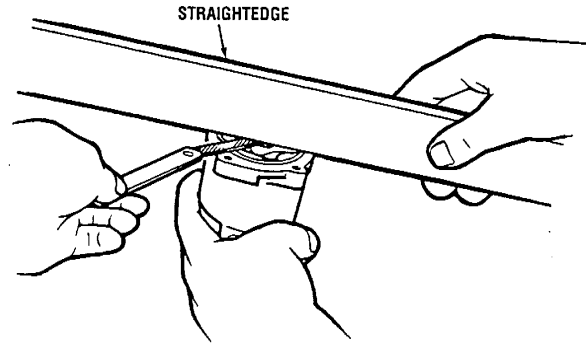

Reassembly

Reassemble the oil pump in the reverse of the order of disassembly.

NOTE: When installing the rotors into the body, be sure that the tally marks on the rotors are positioned toward the cover.

Pump cover tightening torque:

5.8 – 8.7 ft-lb (0.8 – 1.2 m·kg)

Installing the Oil Pump

Install the six components in the reverse of the order of removal.

NOTE: When installing the oil pump set screw, apply sealing compound on the set screw threads.

LUBRICATION SYSTEM SPECIFICATIONS

Lubrication system type		Pressure-fed
Oil pump	Type	Trochoid
	Relief valve opening pressure	92.4 lb/in ² (6.5 kg/cm ²)
Oil filter	Type	Full flow, paper element, spin-on type
	Oil filter relief valve opening pressure	14.2 lb/in ² (1.0 kg/cm ²)
Oil cooler	Type	Water cooled
Oil filter body	Relief valve opening pressure	56.9 lb/in ² (4.0 kg/cm ²)
Oil sump capacity (not including oil filter/cooler assembly)		6.3 U.S. quarts (6.0 liters)
Oil filter capacity		1.1 U.S. quarts (1.0 liters)
Oil Grade		API Specification CF or CG-4, SAE 30, 10W-30, 15W-40



COOLING SYSTEM

DESCRIPTION

Westerbeke marine diesel engines are designed and equipped for fresh water cooling. Heat produced in the engine by combustion and friction is transferred to fresh water coolant which circulates throughout the engine. This circulating fresh water coolant cools the engine block, its internal moving parts, and the engine oil. The coolant is, in turn, cooled by raw water, and the raw water carries the transferred heat overboard through the exhaust system. The fresh water coolant and raw water circuits are independent of each other. Using only fresh water coolant within the engine allows the cooling water passages to stay clean and free from harmful deposits.

Coolant Pump

The fresh water coolant is pumped through the engine by a circulating pump. The coolant passes through the thermostat into the manifold, to the heat exchanger where it is cooled, and returned to the engine block via the suction side of the circulating pump.

Raw Water Pump

The raw water flow is created by a positive displacement impeller pump. This pump draws water directly from the raw water source (ocean, lake, or river) through a hose to the water strainer. The raw water passes from the strainer through the raw water pump to the heat exchanger, then to the transmission oil cooler (propulsion engines only). The raw water is then discharged into the water-injected exhaust elbow, mixing with and cooling the exhaust gasses. This mixture of exhaust gas and raw water is discharged overboard by the engine's exhaust gas discharge pressure.

The raw water pump is a self-priming, rotary pump with a non-ferrous housing and a neoprene impeller. The impeller has flexible vanes which wipe against a curved cam plate within the impeller housing, producing the pumping action. This pump must not be run dry as water acts as a lubricant for the impeller.

Heat Exchanger

The engine heat is transferred externally from the fresh water coolant to the raw water in the heat exchanger. The raw water flows through tubes in the heat exchanger while the fresh water coolant flows around the tubes. The engine heat is conducted from the fresh water coolant through the tube walls to the raw water.

Thermostat

A thermostat, located near the manifold at the front of the engine, controls the coolant temperature as the coolant continuously flows through the closed cooling circuit. When the engine is first started, the closed thermostat prevents coolant from flowing (some coolant is by-passed through a hole in the thermostat to prevent the exhaust manifold from overheating). As the engine warms up, the thermostat gradually opens.

When the engine is started cold, external coolant flow is prevented by the closed thermostat (although some coolant flow is bypassed around the thermostat to prevent the exhaust manifold from overheating). As the engine warms up, the thermostat gradually opens, allowing the engine's coolant to flow unrestricted to the external portion of the cooling system.

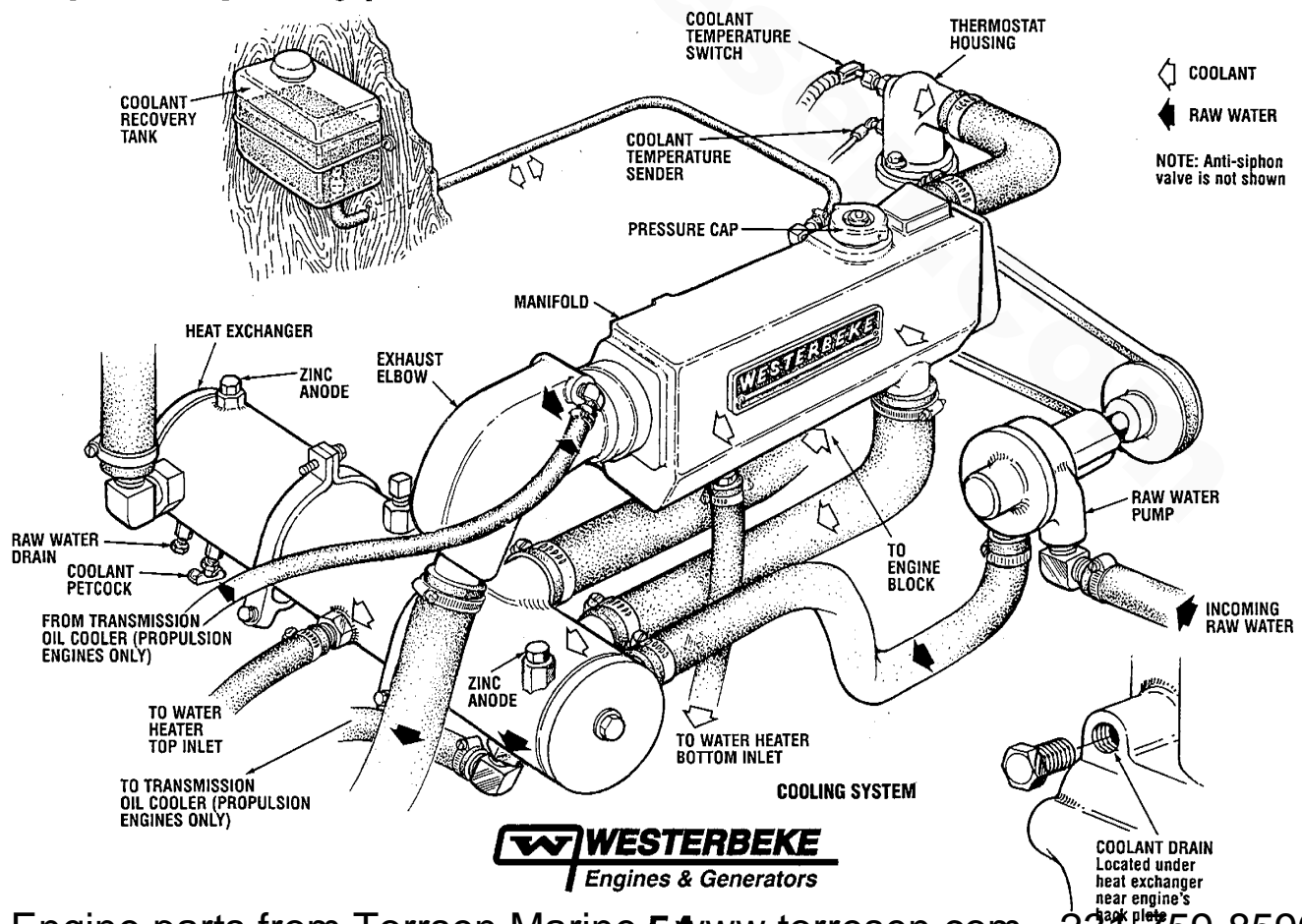

COOLING SYSTEM

HEAT EXCHANGER

The heat exchanger should be inspected and serviced during an engine overhaul.

1. Disconnect the hoses and remove the hose fittings, petcock, drain plugs and zinc anode. Also remove the covers and gaskets.
2. Inspect the tube (casing) for wear and dents; if necessary, replace the heat exchanger.
3. Clean out any zinc debris, and pressure test the coolant and raw water passages.
4. When reassembling, install new gaskets and O-rings. Apply some lubricant to the new gaskets and to the petcocks and fittings as you install them.
5. Install a new zinc anode.

NOTE: All of the above can be accomplished by sending the heat exchanger to a heat exchanger/radiator service shop. They will also service the transmission and engine oil coolers.

6. Repaint the assembled heat exchanger with Westerbeke heat-resistant spray enamel.
7. Reconnect all hoses, replacing them as needed.
8. Refill the system with coolant.
9. Pressure test the system and check for leaks.

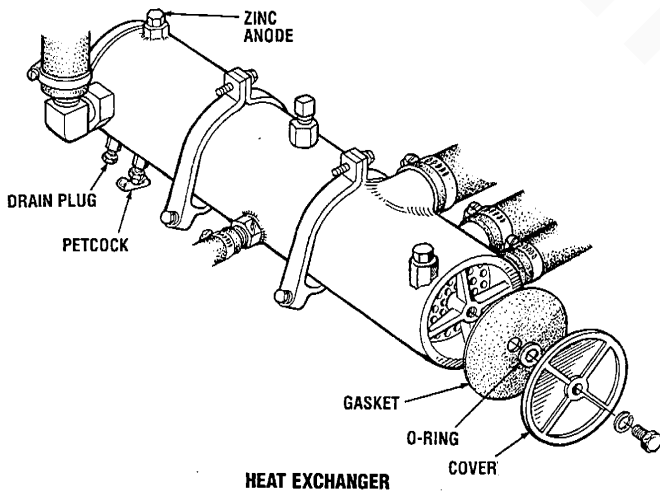

THERMOSTAT

Visually check the thermostat for damage. Then put it in water and raise the water temperature gradually to test its valve opening temperature. Replace if defective.

CAUTION: The wax pellet-type thermostat remains closed if its heat-sensing part is defective. Leaving this uncorrected would cause the engine to overheat.

Replacing The Thermostat

Remove the cap screws and disassemble the thermostat housing as shown. When installing the new thermostat and gasket, apply a thin coat of sealant on both sides of the gasket before pressing it into place. Do *not* over-tighten the cap screws.

Run the engine and check for normal temperatures and that there are no leaks at the thermostat housing.

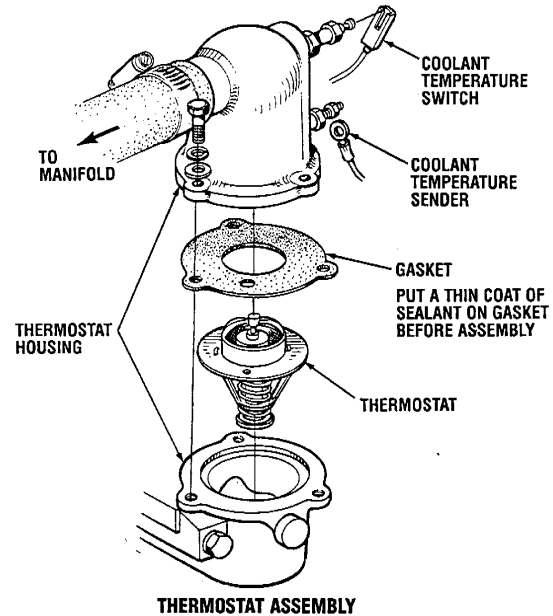

COOLANT PUMP

The coolant (fresh water) pump is a centrifugal-type pump, and is belt-driven.

Removal

1. Drain the engine coolant into a suitable container.
2. Remove the following components in sequence:
 - a. Coolant pump pulley
 - b. Alternator drive belt
 - c. Spacer
 - d. Coolant pump
 - e. Coolant pump gasket

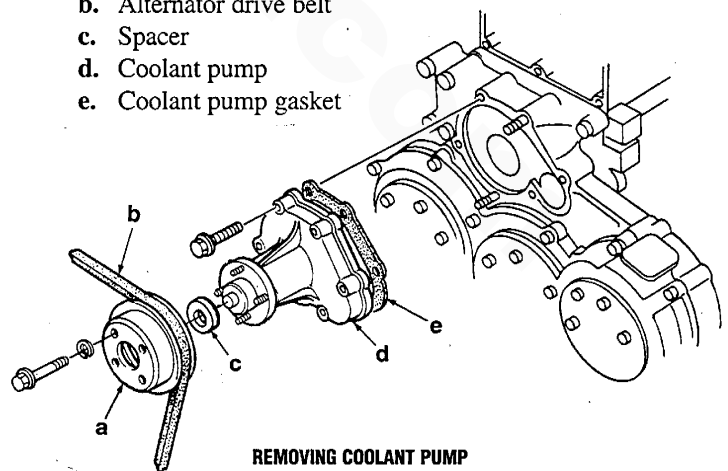

COOLING SYSTEM

Disassembly

Disassemble the coolant pump in the following sequence:

1. Pulley flange
2. Shaft/bearing
3. Housing and gasket
4. Impeller seal
5. Impeller

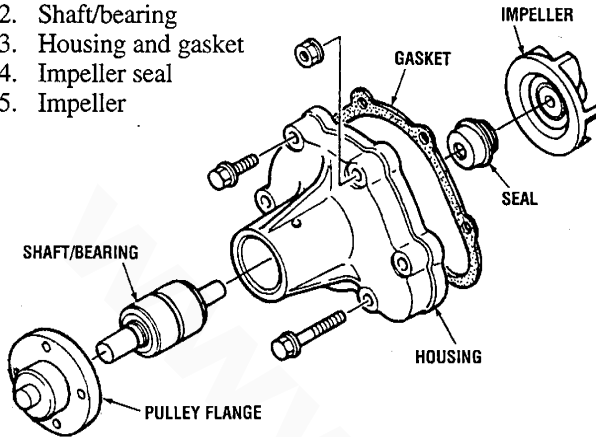

1. Press out the coolant pump pulley flange using a suitable puller and a press.

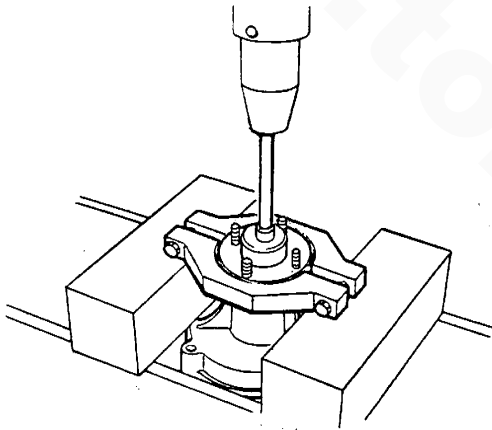

2. Press out the water pump impeller and shaft/bearing using the water pump impeller support block (Mazda #49 0823 146) and a press.

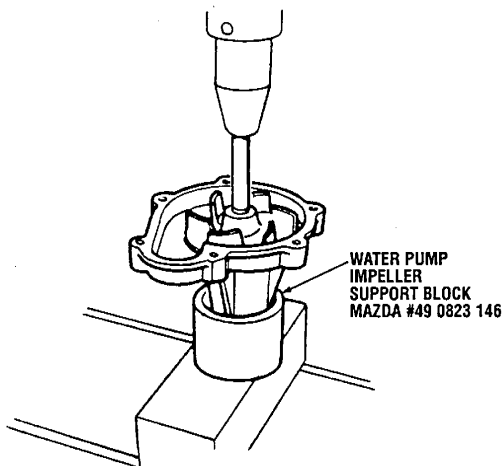

3. Tap out the seal using a pipe of the specified size.

NOTE: The outer diameter of the pipe should be below 1.1 in (28 mm) and the inner diameter of the pipe should be above 0.55 in (14 mm).

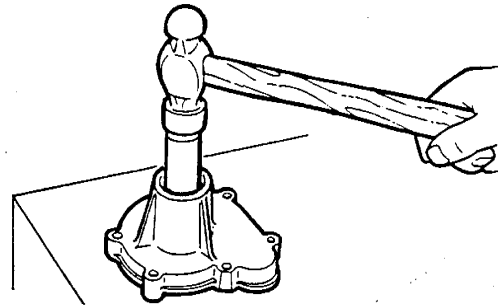

Inspection

Inspect the coolant pump parts for the following conditions, and replace if necessary.

1. Cracking of the water pump body.
2. Wear in the areas that the impeller contacts the seal.
3. Breakage of the seal spring.
4. Check that the shaft/bearing rotates easily, and check for abnormal noise.

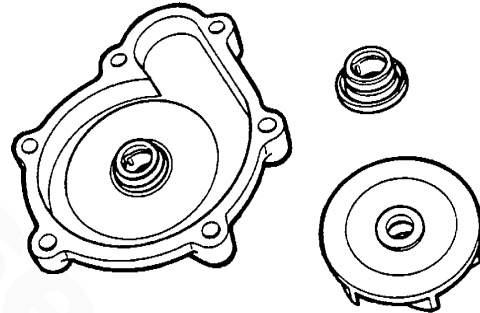

Reassembly

1. Use a pipe of the specified diameter to press the shaft bearing into the water pump body.

CAUTION: Use a pipe with an inner diameter of 1.0 in (26 mm) or more and press the end of the pipe against the outer race of the shaft bearing. Make sure the shaft bearing is inserted straight. When the inserting force suddenly increases, the shaft bearing is pressed in.

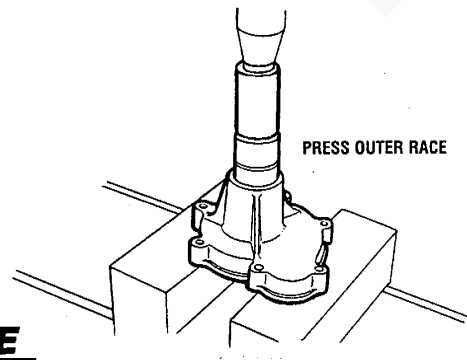

COOLING SYSTEM

2. Apply gasket cement to the contact surface between the seal and the pump body.
3. Apply coolant to the seal.
4. Press the seal into the pump body using a pipe of the specified size.

CAUTION:

- a) Check to be sure that there is no oil on the seal's sliding surface.
- b) Using a pipe with an inner diameter of 1.1 in (27 mm) or more, press in the seal making sure it goes in straight.

5. Dry off both the seal and the impeller's sliding surface with compressed air.

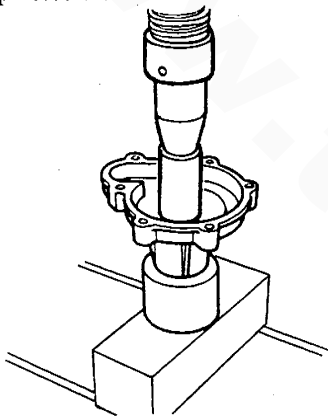

6. Press the impeller onto the shaft/bearing.

CAUTION:

- a) When pressing, make sure the lower edge of the shaft rests on a block.
- b) Press the water pump impeller until its edge is flush with the shaft.
- c) After installing, check that the impeller can be easily moved by hand.

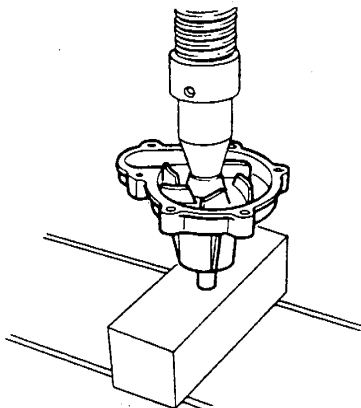

7. Press in the water pump flange using a pipe of the specified size.

CAUTION:

- a) Use a pipe with an inner diameter greater than 0.75 in (19 mm) and an outer diameter of less than 1.18 in (30 mm).
- b) Press in the flange until the length of the protruding portion is about 0.413 in (10.5 mm).

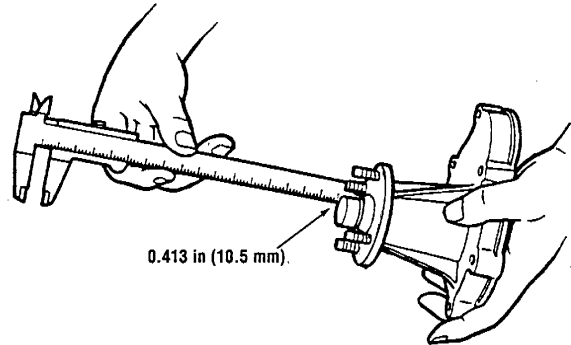

Installation

The coolant pump installation sequence is the reverse of the removal sequence.

COOLING SYSTEM

RAW WATER PUMP

NOTE: Since completely rebuilding a damaged or worn pump from individually purchased parts would almost match the price of a new pump, Westerbeke recommends that a new pump be purchased.

Before disassembling the raw water pump, inspect the pump by rotating the drive shaft. If it is rough, frozen, or seems to have excessive play, a major overhaul may be needed.

Disassembly

The pump, as removed from the engine, will have hose attachment nipples threaded into its inlet and outlet ports. The nipples may be left in place or removed if they interfere with the pump disassembly. Note the port location and positioning if removed.

1. Loosen the set screw with an allen wrench and remove the water pump pulley from the shaft, taking care not to lose the key.

2. Remove the four impeller cover screws, the impeller cover and its gasket.

NOTE: Replacement of the impeller cover gasket is recommended, however, if you are going to reuse it, keep the gasket well lubricated until the pump is reassembled. If it's allowed to dry, the gasket will shrink and not be reusable.

3. Pull out the impeller with long-nose pliers or a pair of screwdrivers.

4. Remove the cam screw and cam.

5. Remove the bearing housing, releasing the shaft, bearing and seal assembly. This will allow the bearing and seal assembly to be inspected.

NOTE: It may be necessary to use a drift and arbor press to press the bearing and seal assembly from the shaft.

6. Inspect all parts and replace those showing wear or erosion.

CAUTION: If any of the vanes have been broken off the impeller, they must be found to prevent blockage in the cooling circuit. They often can be found in the heat exchanger.

7. Use the illustration to assist in reassembling the raw water pump.

a. Apply a small amount of petroleum jelly to the seat's surface and to the impeller shaft at reassembly.

b. When positioning the cam in the housing, use a small amount of Permatex #1 on the inner cam surface and cam screw head; remove any excess from the impeller housing.

c. Apply a light film of silicon or petroleum jelly to the inner surface of the housing for the impeller.

d. Apply a thin coating of lubricant to the impeller cover gasket.

8. When the pump is assembled, reposition and tighten the hose nipples into the pump housing; use Teflon sealant on the nipple thread. Assemble the pump to the engine and attach the hoses and the belt.

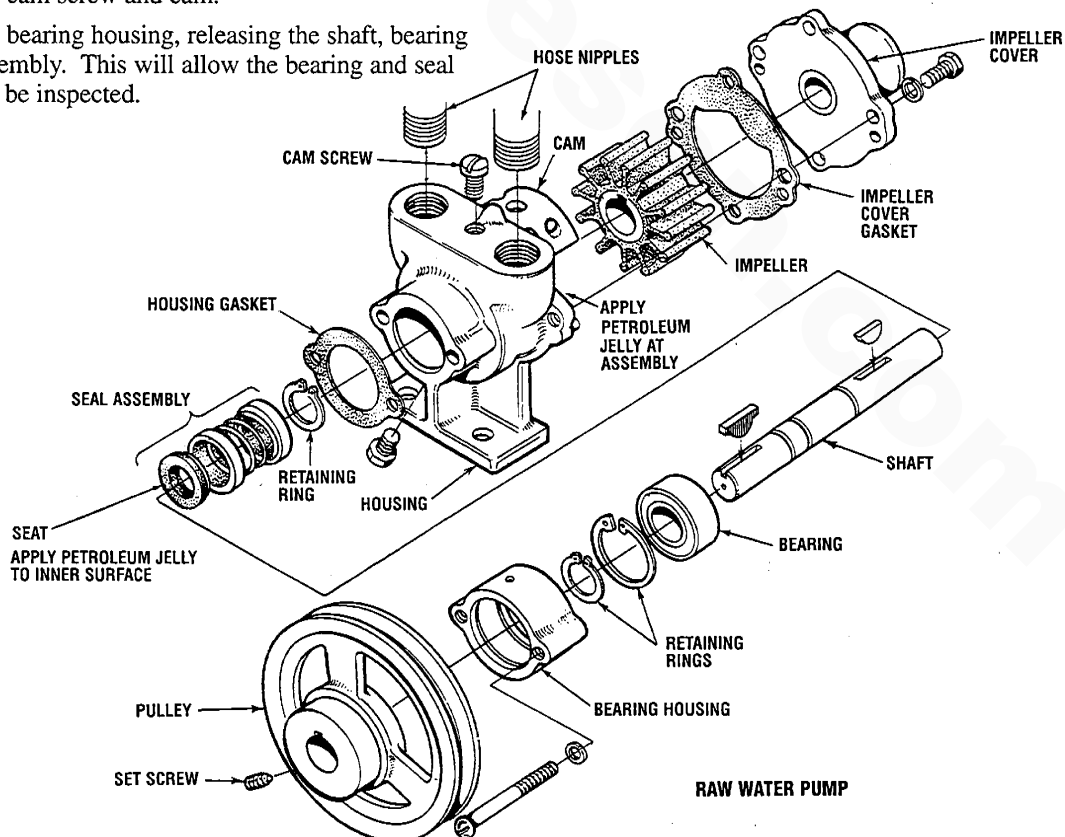

FUEL SYSTEM

INTRODUCTION

1. The fuel system uses 5-hole type injection nozzles and an in-line injection pump (Bosch type). The injection pump generates a high injection pressure of 2417 lb/in² (170 kg/cm²), and the fuel is injected from the injection nozzles as a fine spray and at a wide angle into the combustion chamber, improving combustion and increasing power.
2. The fuel, which is drawn up through the fuel filter/water separator from the fuel tank, is filtered and then supplied to the injection pump.

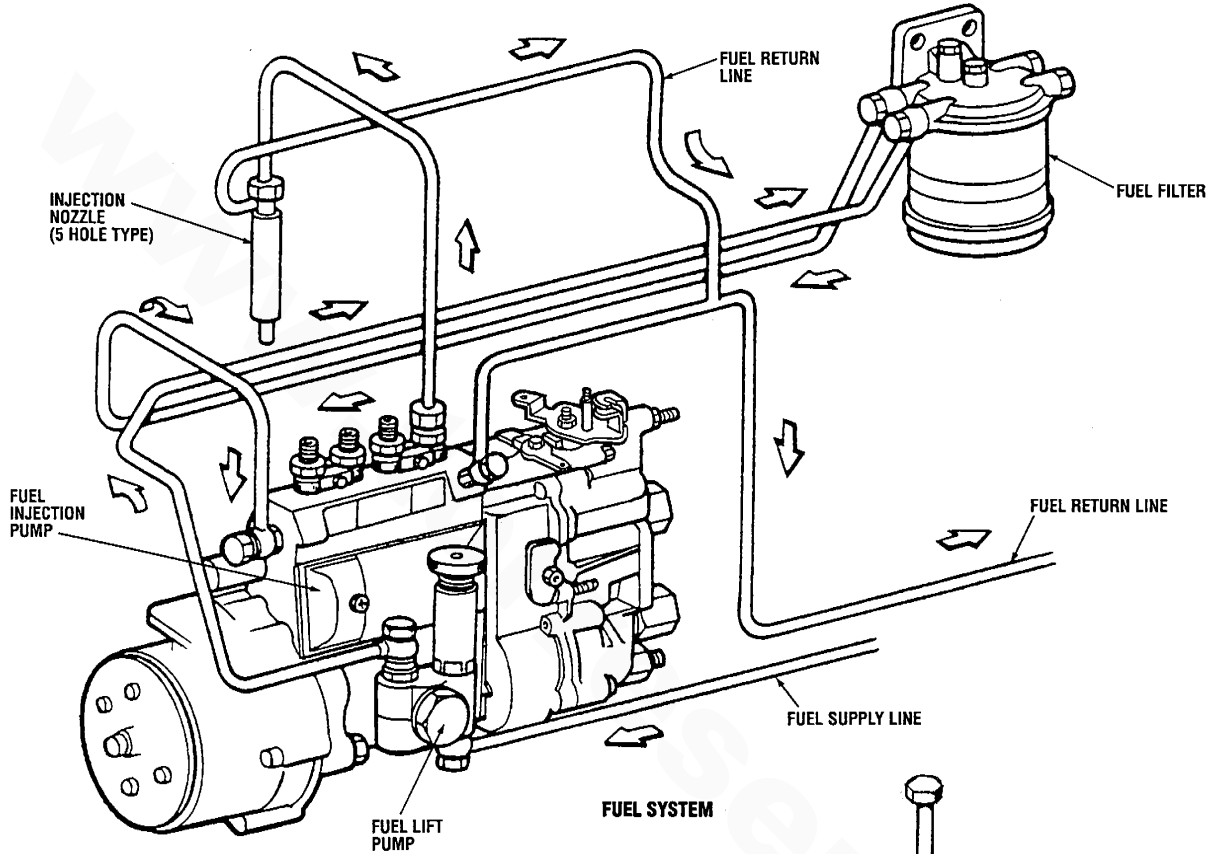

CHANGING THE FUEL FILTER

1. Shut off the fuel supply.
2. Open the bleed screw on the top of the filter. Place a container under the fuel filter and open the drain on the bottom of the bowl and drain the fuel.
3. Close the drain and unscrew the bolt that secures the bowl. The bowl and the filter will drop down.
4. Clean the base. Install a new sealing ring in the base making certain that it lies squarely on the base recess.
5. Replace the upper sealing ring and the o-ring in the filter head. Install the new filter element and re-install the retaining bolt.

NOTE: Apply fuel to the seal rings and o-ring before installing.

6. Bleed the air from the filter assembly.

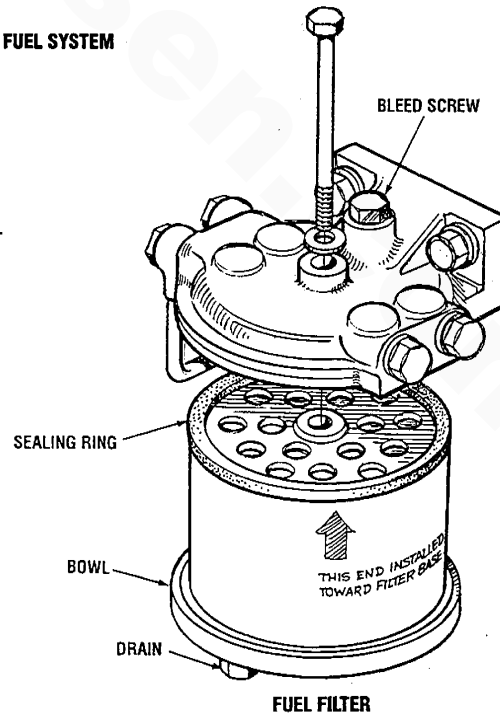

FUEL SYSTEM

FUEL FEED PUMP STRAINER

An additional fuel screen is located in the feed pump. This screen (strainer) is removed for cleaning by releasing the banjo bolt at the bottom. This screen should be cleaned every 250 operating hours. Use compressed air and/or clean with kerosene.

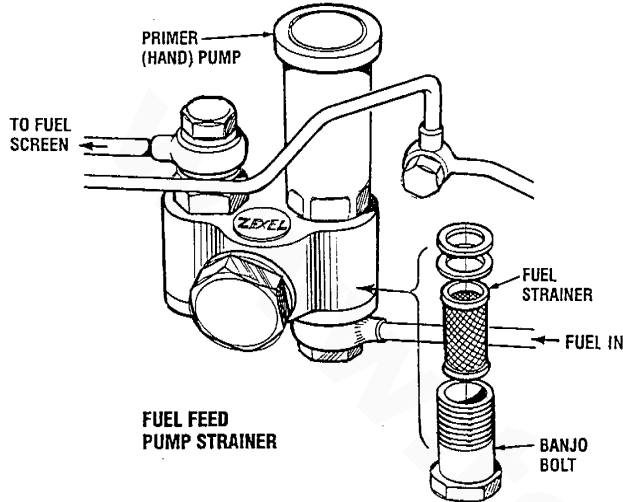

Bleeding air from the fuel line between the engine-mounted fuel filter and the injection pump.

1. Confirm that the plugs on the fuel filter/water separator are closed and that the fuel lines are connected.
2. Turn the fuel lift pump primer counterclockwise to release it.
3. Disconnect the fuel return hose.

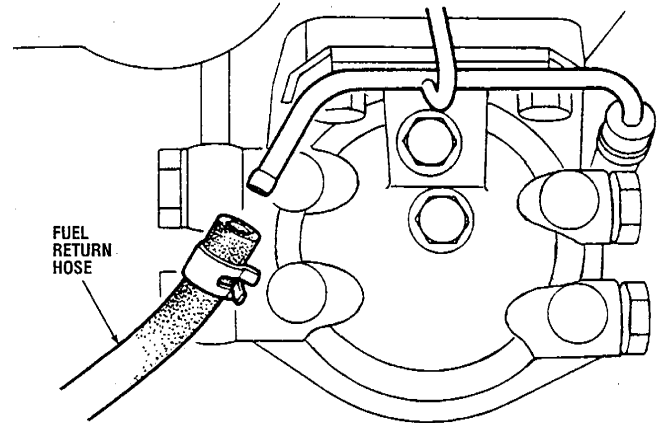

4. Repeatedly depress and release the primer until only fuel (no air bubbles) flows out of the air bleeding plug hole.
5. Connect the fuel return hose.
6. Depress the primer and turn it clockwise, to lock it.

BLEEDING THE FUEL SYSTEM

If air is present in the fuel lines, the engine may be difficult to start, there may be insufficient power, or hunting may occur when idling.

Air bleeding must be performed after the injection pump has been installed, and after checking or adjusting the injection timing.

Bleeding air from the fuel line between the fuel tank and the engine-mounted fuel filter.

1. Confirm that the plugs on the fuel filter/water separator are closed and that the fuel lines are connected.
2. Turn the primer on the fuel lift pump counterclockwise to release it.
3. Loosen the air bleeding plug on the fuel filter.
4. Repeatedly depress and release the primer until only fuel (no air bubbles) flows out of the air bleeding plug hole.
5. Retighten the air bleeding plug.
6. Depress the primer and turn it clockwise to lock it.

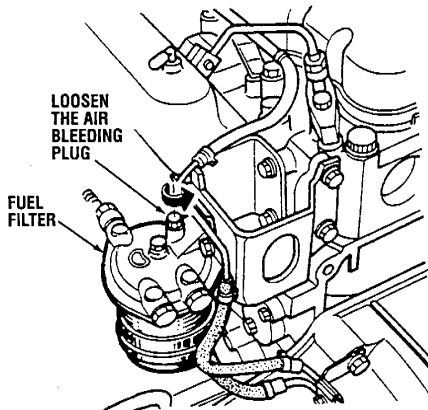

CAUTION: If hunting occurs when idling or there is less engine power after air bleeding, then loosen the injector ends of all fuel lines, and bleed air by using the engine starter to crank the engine until only fuel comes out. After bleeding the air, start the engine and check for fuel leaks.

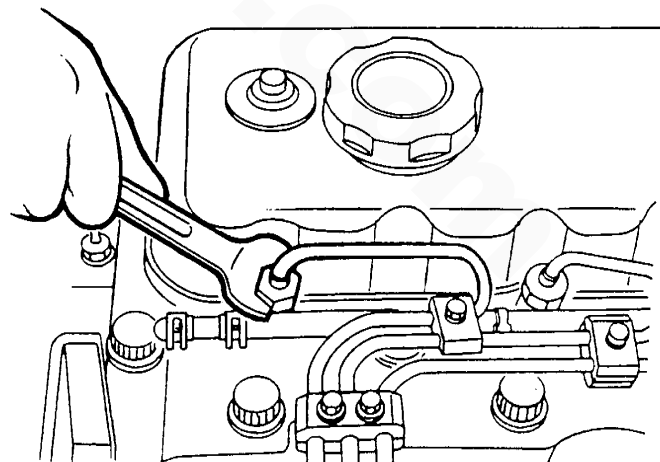

LOOSEN THE INJECTOR ENDS OF ALL FUEL LINES



FUEL SYSTEM

TESTING THE FUEL INJECTORS

NOTE: The fuel injectors must be serviced in a clean room environment.

Removing the Fuel Injectors

1. Disconnect the high pressure fuel lines from the injectors, then loosen the lines at their attachment to the injection pump and move them out of the way of the injectors. Avoid bending the lines.
2. Remove the fuel return line in its entirety from the top of the injectors. Take care not to lose the two sealing washers and banjo bolt that attaches the fuel return line to each injector.
3. Remove the fuel injector holder bracket mounting nuts, then remove the holder brackets.
4. Remove the fuel injectors.

NOTE: Clean the area around the base of the injector prior to lifting it out of the cylinder head to help prevent any rust or debris from falling down into the injector hole. If the injector will not lift out easily and is held in by carbon build-up or the like, work the injector side-to-side with the aid of the socket wrench to free it, and then lift it out.

The injector seats in the cylinder head on a copper sealing washer. This washer should be removed with the injector and replaced with a new washer when the injector is reinstalled.

5. Remove the gaskets.
6. Remove the O-rings.

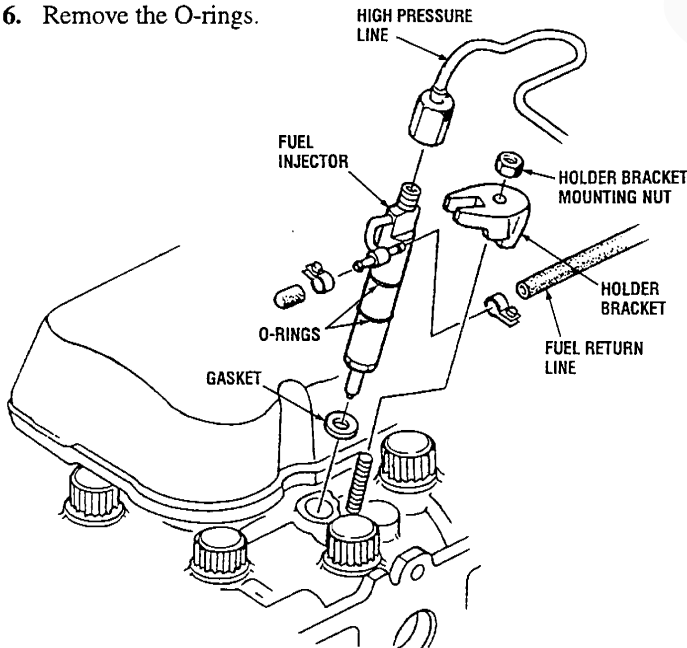

REMOVING THE FUEL INJECTORS

Fuel Injector Components

The fuel injector consists of the following parts:

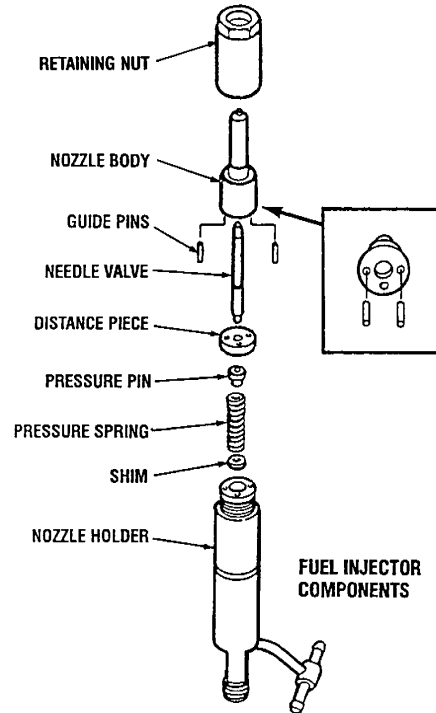

Checking the Injection Starting Pressure

1. Set the nozzle tester in a clean place where there is no dust or dirt.
2. Mount the nozzle and the nozzle holder on the nozzle tester.
3. Use new fuel that has an approximate temperature of 68°F (20°C).
4. Bleed the air in the nozzle line by pumping the nozzle tester handle several times.
5. Slowly lower the nozzle tester handle and check the reading on the pressure gauge when the injection starts.

Injection starting pressure:

2417 – 2489 lb/in² (170 – 175 kg/cm²)

CAUTION: The spray nozzle velocity is such that it may penetrate deeply into the skin of the fingers and hands, destroying tissue. If it enters the bloodstream, it may cause blood poisoning.

FUEL SYSTEM

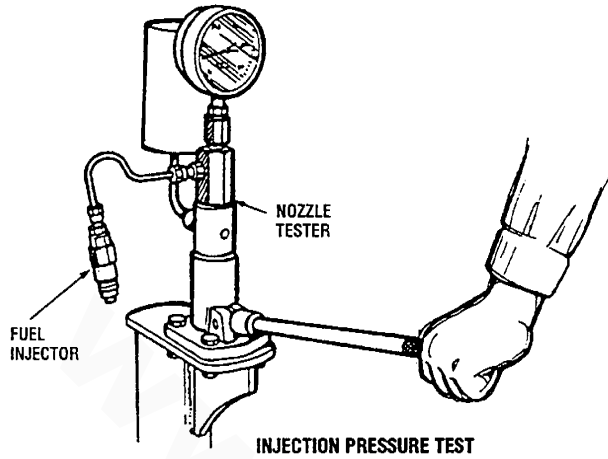

- If the injection starting pressure is not within the specified range, adjust it by replacing the shim with one of a more appropriate thickness.

The shims have 21 different thicknesses at intervals of 0.002 in (0.05 mm), from 0.0197 in (0.50 mm) to 0.059 in (1.50 mm). If the thickness of a shim is increased 0.002 in (0.05 mm), the injection pressure increases approximately 71.1 lb/in² (5.0 kg/cm²).

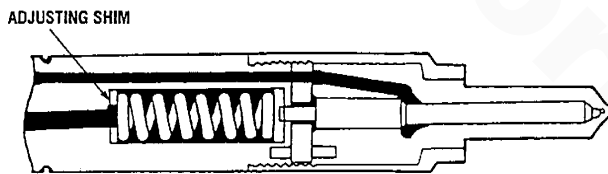

FUEL INJECTOR ADJUSTING SHIM

Tightness of the Valve Seat

Apply a pressure of 2133 lb/in² (150 kg/cm²) and check if fuel leaks from the injection nozzle holes. If fuel leaks, disassemble, wash and recheck the injector nozzle or replace it.

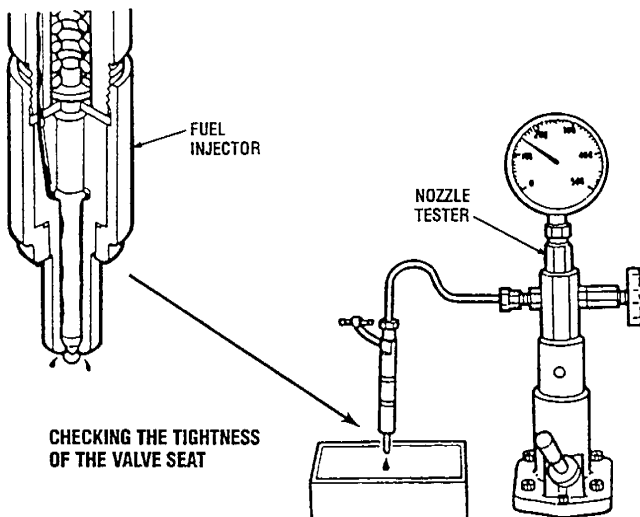

CHECKING THE TIGHTNESS OF THE VALVE SEAT

Inspecting the Spray Pattern

- Mount the nozzle and nozzle holder on the nozzle tester.
- Bleed the air in the nozzle line by pumping the nozzle tester handle several times.
- Keep the reading on the pressure gauge of the nozzle tester just below the injection starting pressure while pumping the handle of the nozzle tester as quickly as possible so that a pulsating whistling sound is heard. Check the atomization of the fuel injected from the nozzle (see illustration):

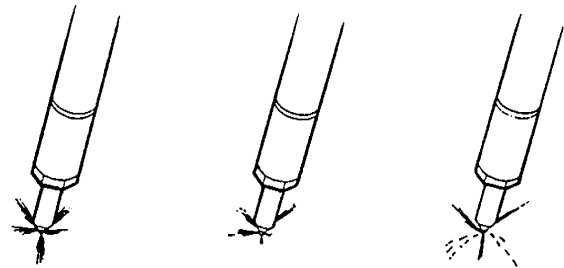

NORMAL PATTERN

FAULTY PATTERN

FAULTY PATTERN

FUEL INJECTOR SPRAY PATTERNS

Normal Pattern: The fuel is sprayed uniformly and finely from all five injection nozzle holes.

Faulty Pattern: The number of fuel sprays and fineness of the injected fuel is substandard.

If the condition of the injected fuel is substandard, disassemble, wash and recheck the injection nozzle or replace it.

Checking the Nozzle Body and Needle Valve

- Check for damage to the valve seat of the needle valve and check for damage to other parts.
- Check for damage to the nozzle body. Hold the nozzle body upright and insert four-fifths of the needle valve. Then release the needle valve and check that it drops into the valve seat under its own weight.

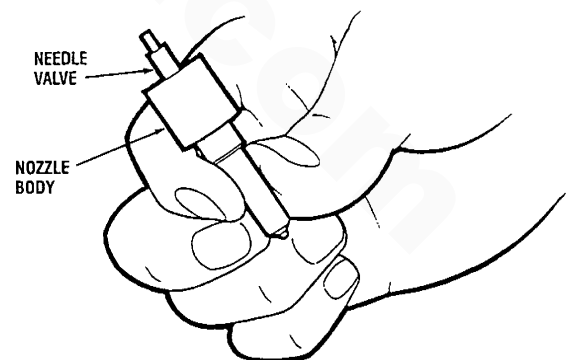

CHECKING THE NOZZLE BODY AND NEEDLE VALVE

FUEL SYSTEM

Reassembly

Be sure to do the following when reassembling the fuel injector:

1. Tighten the nozzle body onto the nozzle holder to the specified torque.

Nozzle torque: 29 – 36 ft-lb (4.0 – 5.0 kg-m)

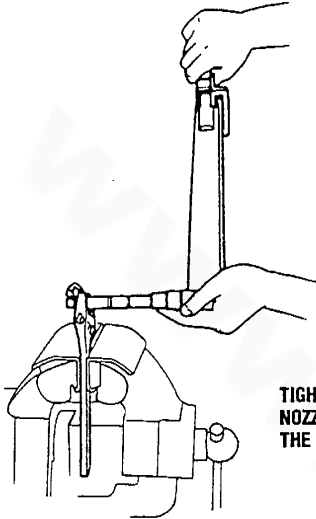

TIGHTENING THE NOZZLE BODY ONTO THE NOZZLE HOLDER

2. After assembling the fuel injector, check the injection starting pressure and the spray pattern.

Injector Installation

The fuel injector installation sequence is the reverse of the removal sequence. Make sure to include the following:

1. Use new gaskets – do not reuse the old gaskets.
2. Replace the copper sealing washer for each injector.
3. Tighten the fuel injector holder bracket mounting nuts to the specified torque.

Bracket mounting nuts torque:

34.0 – 40.0 ft-lb (4.7 – 5.5 kg-m)

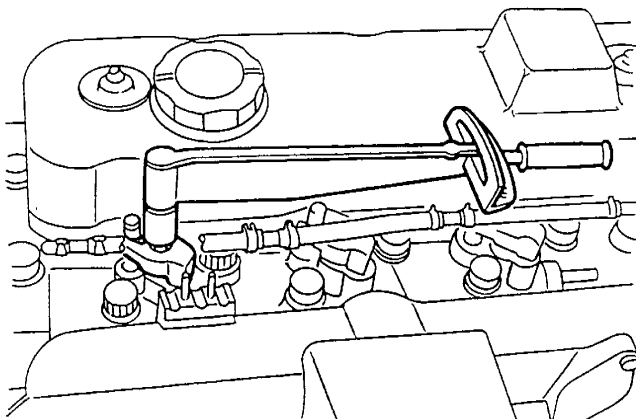

TORQUING THE FUEL INJECTOR HOLDER BRACKET

FUEL INJECTION PUMP

NOTE: The fuel injection pump is a very important component of the diesel engine, requiring the utmost care in handling. It has been thoroughly bench-tested, and the owner/operator is cautioned not to attempt to service it. If the fuel injection pump requires servicing, remove it and take it to an authorized Kiki fuel injection pump service facility.

The only adjustment the servicing mechanic should make to the fuel injection pump are the adjustments for idle speed (see IDLE SPEED ADJUSTMENT under ENGINE ADJUSTMENTS), and injection timing (see INJECTION TIMING ADJUSTMENT, below).

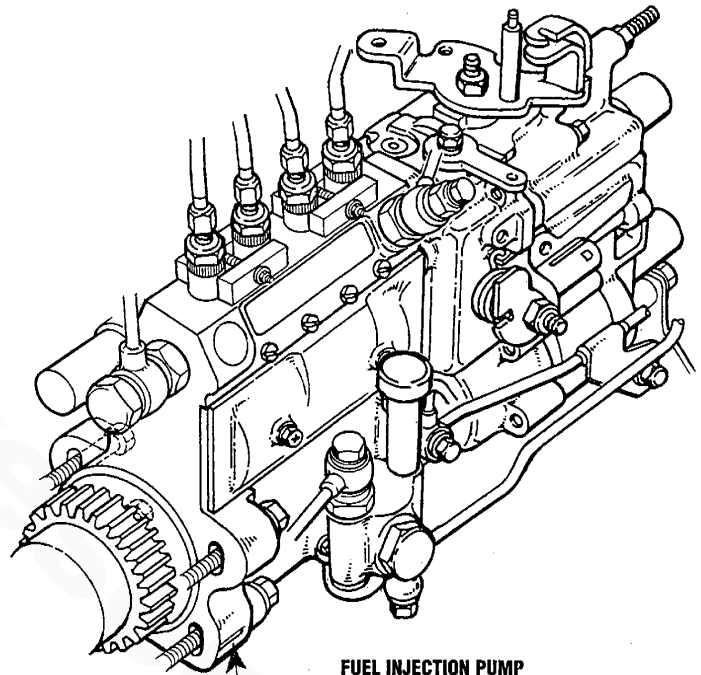

FUEL INJECTION PUMP

SCRIBE MARK

ALIGN THE SCRIBE MARK ON THE INJECTION PUMP FLANGE WITH THE SCRIBE MARK ON THE GEAR CASE, THIS WILL PLACE THE INJECTION PUMP IN PROPER TIMING WITH THE ENGINE.

STARTER MOTOR

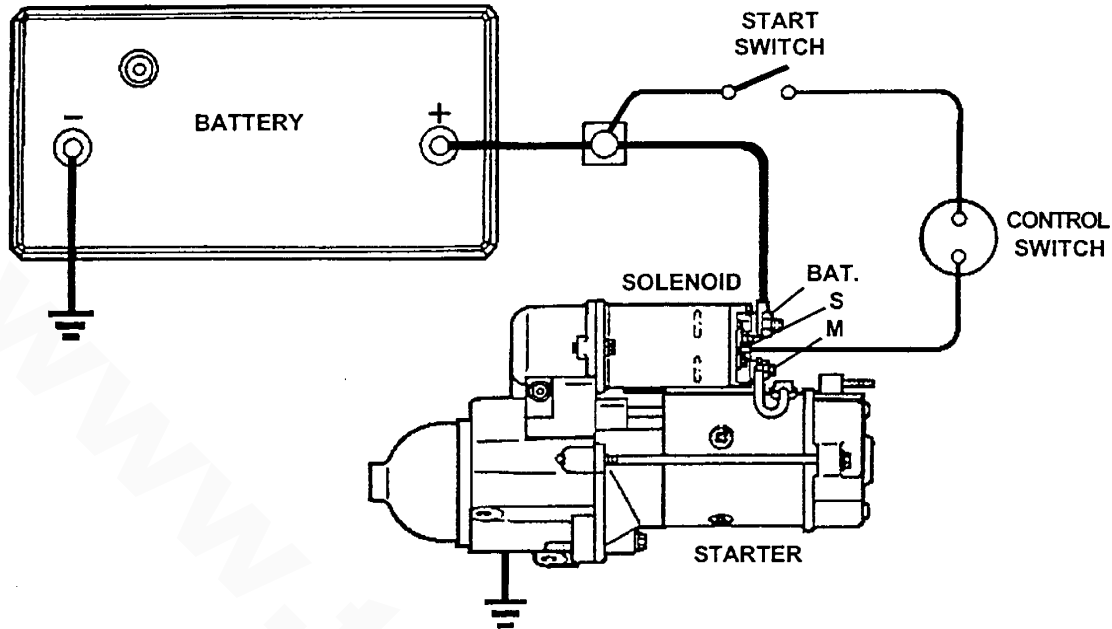

FIGURE 1. STARTER WIRING CIRCUIT

TROUBLESHOOTING

To independently test the starter it is necessary to remove it from the engine. However, before doing this, checks should be made to ensure that the problem is with the starter and not with the engine, battery, wiring or switches. When the other possible problem sources have been eliminated, then remove and test the starter. Comparison of test results with the Troubleshooting chart will aid in isolating the problem within the starter to specific components. This will determine the repair or repairs needed to restore the starter to serviceability.

Battery Test

Realistic testing, as well as successful operation, requires a fully charged battery capable of supplying the current needs of the starting system. Step one in troubleshooting the starting system is to test the battery. Follow the battery manufacturer's instructions.

Wiring and Switches

Visual Inspection

Visually inspect all wiring and switches in the starting circuit for damage and loose or corroded connections. This includes all ground connections. Clean and tighten the connections as required. Replace damaged wiring or components.

Continuity Check

Disconnect the field lead on the starter from the solenoid M terminal and insulate it carefully to prevent accidental contact. Set the transmission in neutral. Use a voltmeter to check for voltage at the solenoid S terminal while the start switch is held in the START position. If voltage is not present at the S terminal, use the voltmeter and the wiring diagram to trace the control circuit and locate the point of voltage loss and correct it as necessary.

Starter Removal

If the battery, wiring and switches are in satisfactory condition and the engine is known to be functioning properly, remove the starter for further testing.

Starter No-Load Test

With the starter removed from the engine, the no-load test can reveal damage that can be corrected by repair or it may indicate the need for component testing after the starter is disassembled. Repair and component test procedures are described in the *UNIT REPAIR* section. The no-load test is also used to test units for normal operation after repair or overhaul. Comparison of test results with the Troubleshooting chart will indicate what corrective action, if any, is required.

STARTER MOTOR

Test Hook-Up (Figure 2)

Connect the starter for the no-load test as shown in the illustration using suitable instruments, battery cables and connecting wiring. Do the following:

1. Secure the starter in a suitable test stand to check its operation.
2. Use a momentary contact, pushbutton switch in the test circuit for a quick release if very high current surges are encountered.
3. Make all connections or disconnections with the switch open and the carbon pile load turned off.
4. If sparking or current flow in the battery circuit is noted when making the connections, the starter solenoid switch contacts may be frozen shut (refer to *TROUBLESHOOTING*).
5. As the *last* step in making the test connection, ground the negative battery cable securely to a clean metal ground on the starter frame.
6. The carbon pile load is used to adjust the operating voltage for comparison with specifications. It may not be necessary in all cases but should be used to eliminate the need for interpolation of test data.

Test Procedure

CAUTION: Keep fingers and tools away from the opening in the D.E. (drive end) housing while testing. The strong shifting action of the solenoid could cause personal injury or damage as the drive pinion moves into the cranking position and spins.

NOTE: During the no-load test, close the switch and operate the starter for cycles of 30 seconds maximum. Between cycles, allow the starter to cool for at least two minutes, otherwise overheating and damage to the starter may result.

1. Momentarily close the switch.
 - a. If there is a high current flow and the starter fails to operate (zero rpm), release the switch immediately. Internal mechanical damage is indicated. Discontinue the test and refer to *TROUBLESHOOTING*.
 - b. If there is no current flow and the starter fails to operate (zero rpm), release the switch immediately. An open circuit is indicated. Discontinue the test and refer to *TROUBLESHOOTING*.
 - c. If there is a current flow and the starter operates, release the switch and proceed with the next step of the no-load test.
2. Close the switch and observe the voltmeter. Adjust the carbon pile load to obtain a 10 volt reading (20 volts on a 24-volt starter). Observe and record the ammeter and rpm readings. Release the switch.
3. Compare the ammeter and rpm readings to those listed under *SPECIFICATIONS* at the end of this section. If the readings are outside the limits shown, refer to *TROUBLESHOOTING* to determine the most likely causes. If the readings are within the limits, the starter is operating normally.

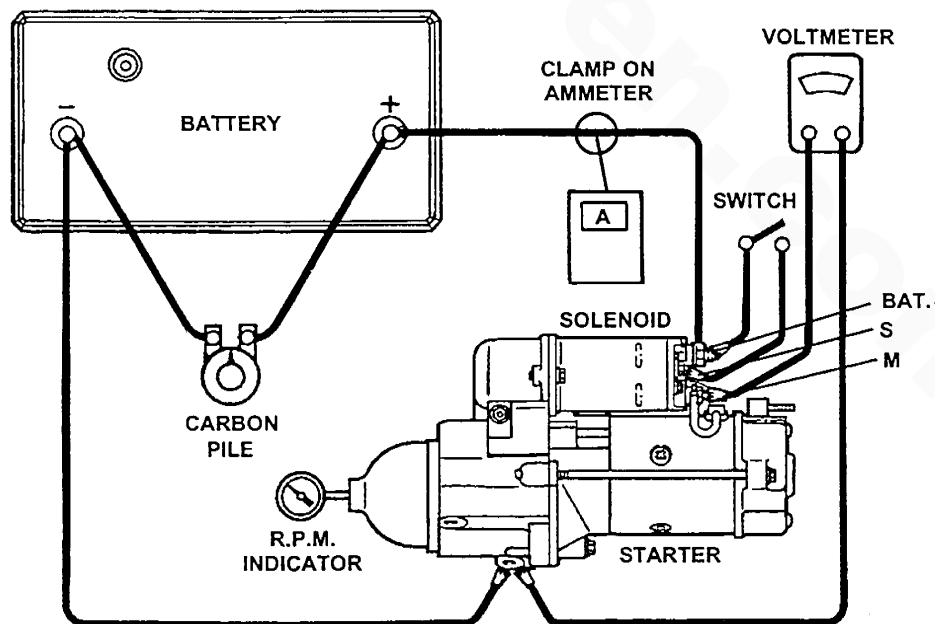

FIGURE 2. STARTER NO-LOAD TEST HOOK-UP



STARTER MOTOR

Troubleshooting

If the results of the no-load test are outside the limits, refer to the following *TROUBLESHOOTING* chart for the proba-

ble cause and its remedy. The problems listed in the chart apply specifically to the no-load test and do not necessarily apply to operation under other circumstances.

PROBLEM	PROBABLE CAUSE	VERIFICATION/REMEDY*
Normal current and speed.	a. Starter OK.	a. Recheck battery, switches and wiring, including battery cable loss. Check if starter operation on engine is slow or sluggish.
Current flow with test circuit switch open.	a. Solenoid switch contacts stuck closed.	a. Test and, if necessary, replace solenoid assembly.
Failure to operate with very low or no current.	a. Open solenoid wiring. b. Open field circuit. c. Open armature coil(s) or high insulation between commutator bars. d. Broken brush spring(s) or worn brushes.	a. Inspect and test solenoid assembly. b. Inspect and test frame and field assembly. c. Inspect armature. d. Inspect brushes and brush springs.
Failure to operate with high current.	a. Frozen bearing or other damage to drive train. b. Direct ground in terminals or fields.	a. Inspect bearings, armature, drive shaft and related drive parts. b. Inspect and test frame and field assembly, solenoid assembly, armature and brush installations for shorts.
Low speed with high current.	a. Excessive friction in bearing(s) or gear reduction unit, bent armature shaft or loose pole shoe, bent drive shaft. b. Shorted armature. c. Grounded armature or fields.	a. Inspect bearing, armature, drive shaft, and gear reduction gears. b. Inspect and test armature. c. Inspect and test frame and field coil assembly and armature.
Low speed with normal (or low) current.	a. High internal electrical resistance caused by poor connections, defective leads or dirty commutator. b. Causes listed under <i>Failure to operate with very low or no current</i> .	a. Inspect internal wiring, electrical connections and armature commutator. b. Remedies listed under <i>Failure to operate with very low or no current</i> .
High speed with high current.	a. Shorted fields.	a. Inspect and test field and frame assembly.

* Refer to the *UNIT REPAIR* section for required disassembly, inspection, test, and if necessary, repair or replacement instructions.

STARTER REPAIR

NOTE: Always install fasteners at their original locations. If it is necessary to replace fasteners, use only the correct part numbers or equivalent. If the correct part number is not available, use only a fastener of equal size and strength. Use a torque wrench to tighten fasteners when a torque value is specified. Torques specified are for dry, unlubricated fasteners unless otherwise specified.

Introduction (Figure 3)

Figure 3 shows the starter broken down into its component parts and assemblies. Do not attempt to disassemble the following components which are serviced as assemblies:

- Solenoid assembly (1)
- Clutch Drive assembly (2)
- Brush Holder assembly (3)
- Armature assembly (13)
- Frame and Field assembly (19)

This section provides instructions for complete disassembly of the starter as would be the case for overhaul. If the starter is not due for an overhaul, and repair affecting specific parts only is required, the starter may be disassembled only to the extent necessary to gain access to these parts. Parts removed from the starter as subassemblies or groups need not be disassembled for such limited repair unless they contain the affected parts. Total disassembly is recommended however, to ensure that all parts can be thoroughly cleaned and inspected.

In this section the starter is broken down by main groups. These groups are then disassembled into individual parts and assemblies. Illustrations accompany the text to show specific operations. To see the parts relationship of the *complete* starter, refer back to Figure 3.

To begin, make a mark completely down one side of the starter to ensure proper alignment of all its components at assembly. Use a colored pencil or marker that will show on all parts.



STARTER MOTOR

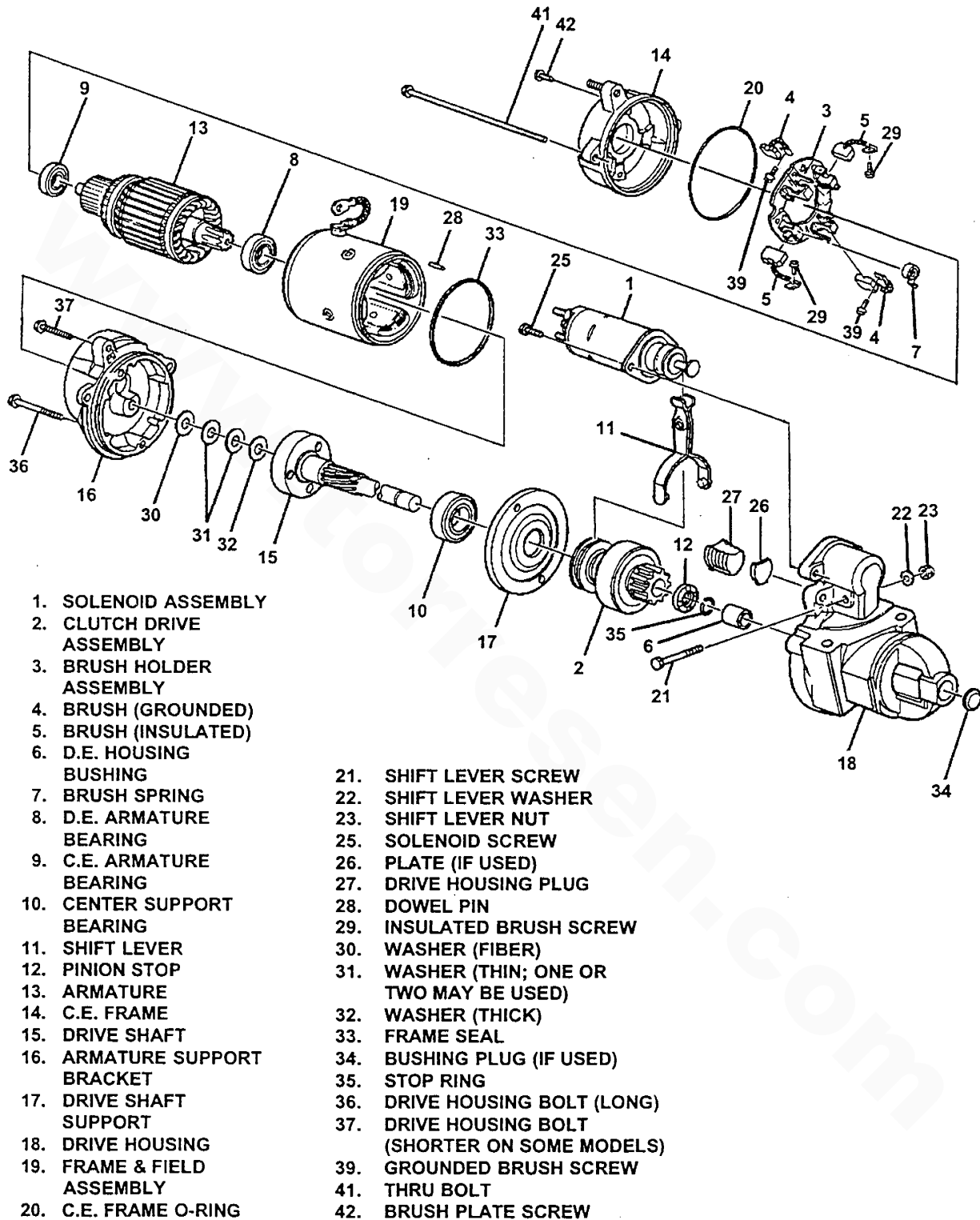

FIGURE 3. STARTER ASSEMBLY



STARTER MOTOR

General Disassembly (Figure 4)

Remove or Disconnect:

1. The motor lead on the frame, field and brush holder group (A) from the solenoid assembly (1). Reinstall the nut on the solenoid terminal.
 - a. Remove the nut on the solenoid, slip off the motor lead and reinstall the nut.
2. Thru bolts (41).
3. Brush plate screws (42).
4. C.E. frame (14) and O-ring (20).

Important:

- a. In the following step, use care not to lose the small dowel pin (28) installed between the frame, field and brush holder group (A) and the gear reduction and drive group (B). This dowel pin is required for assembly and must be saved. If the dowel pin should be lost, it must be replaced with a 2 mm (0.079 in.) dia. x 10 mm (0.394 in.) long pin procured or manufactured locally.

5. Frame, field and brush holder group (A), dowel pin (28) and frame seal (33).
 - a. The armature assembly (13) may come off with the frame, field and brush holder group (A) or may be retained by the gear reduction and drive group (B).
6. Armature assembly (13) with bearings (8 and 9).
 - a. Do not remove the bearings from the armature assembly unless replacement is required (refer to *CLEANING, INSPECTION AND REPAIR*).
7. Solenoid screws (25).
8. Solenoid assembly (1).
 - a. Pivot the inside end of the solenoid assembly (1) out of engagement with the shift lever in the gear reduction and drive group (B) and withdraw the solenoid assembly.

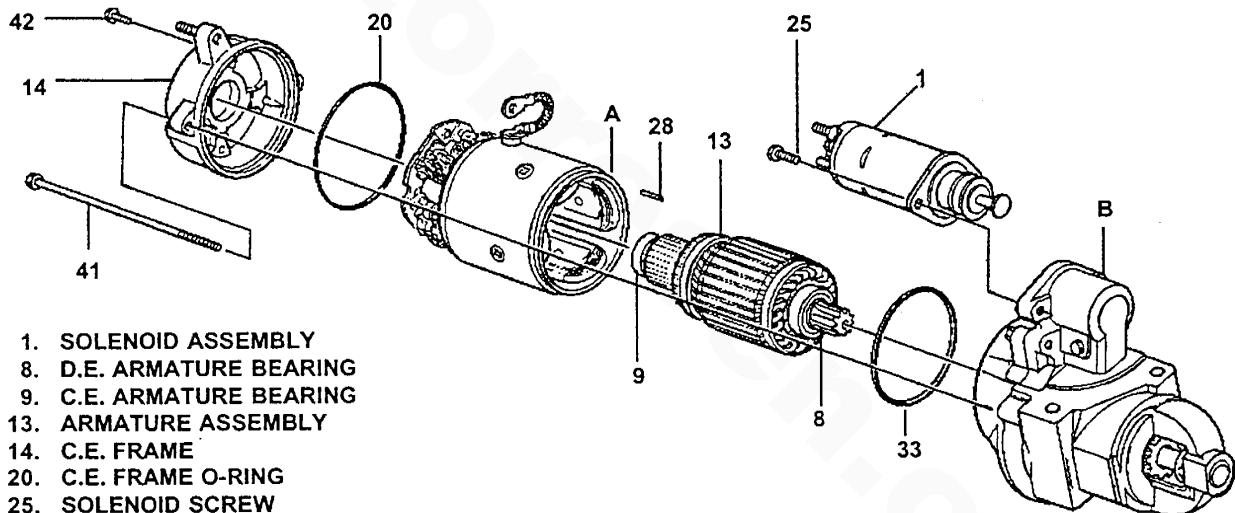

1. SOLENOID ASSEMBLY
8. D.E. ARMATURE BEARING
9. C.E. ARMATURE BEARING
13. ARMATURE ASSEMBLY
14. C.E. FRAME
20. C.E. FRAME O-RING
25. SOLENOID SCREW
28. DOWEL PIN
33. FRAME SEAL
41. THRU BOLT
42. BRUSH, PLATE SCREW
- A. FRAME, FIELD & BRUSH HOLDER GROUP
- B. GEAR REDUCTION & DRIVE GROUP

FIGURE 4. ELECTRICAL GROUP

STARTER MOTOR

Disassembly of Frame, Field and Brush Holder Group (Figure 5)

Remove or disconnect:

1. Insulated brush screws (29).
 - a. Move the brush holder assembly (3) [with the brushes (4 and 5)] away from the frame and field assembly (19) slightly to reach across with a screwdriver and remove the screws (29).
2. Frame and field assembly (19).
3. Grounded brush screws (39).
4. Brushes (4 and 5), if replacement is required.
 - a. Grasp the brush end of each brush spring (7) with needle nose pliers, twist the spring end away from the brush (4 or 5) and withdraw the brush.
5. Brush springs (7), if replacement is required.
 - a. Grasp the brush end of each brush spring (7) with needle nose pliers, twist the spring end away from the brush socket on the brush holder assembly (3) and remove the spring.

NOTE: At this stage of disassembly, all electrical components can be inspected, and if required, independently tested as specified in *CLEANING, INSPECTION AND REPAIR*.

Disassembly of Gear Reduction and Drive Group (Figure 6)

Remove or disconnect:

1. Housing bolts (36 and 37).
 2. Armature support bracket (16).
- Important:**
- a. The washers (30 through 32) may stick to the armature support bracket or to the drive shaft and clutch group (C) as the armature support bracket is removed. In either case, note the position and number of each of these washers.
3. Washers (30 through 32).
 - a. Save the washers; they are to be installed in the same position and number at assembly.
 4. Drive housing plug (27) and plate (26).
 - a. Pry out the drive housing plug using a large screwdriver.
 5. Shift lever nut (23), washer (22) and screw (21).
 6. Remove the shift lever (11) and the drive shaft and clutch group (C) from the drive housing (18) together, then separate them.
 - a. Do not remove the bushing plug (34) or the bushing (6) from the drive housing (18) unless replacement is required (refer to *CLEANING, INSPECTION AND REPAIR*).

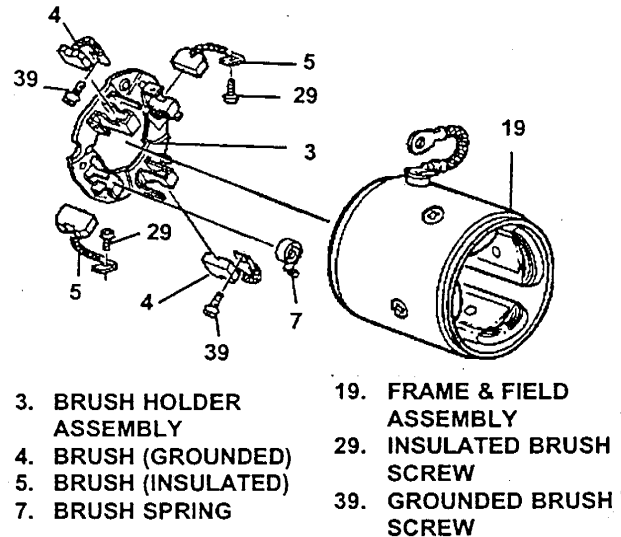

FIGURE 5. FRAME, FIELD AND BRUSH HOLDER GROUP

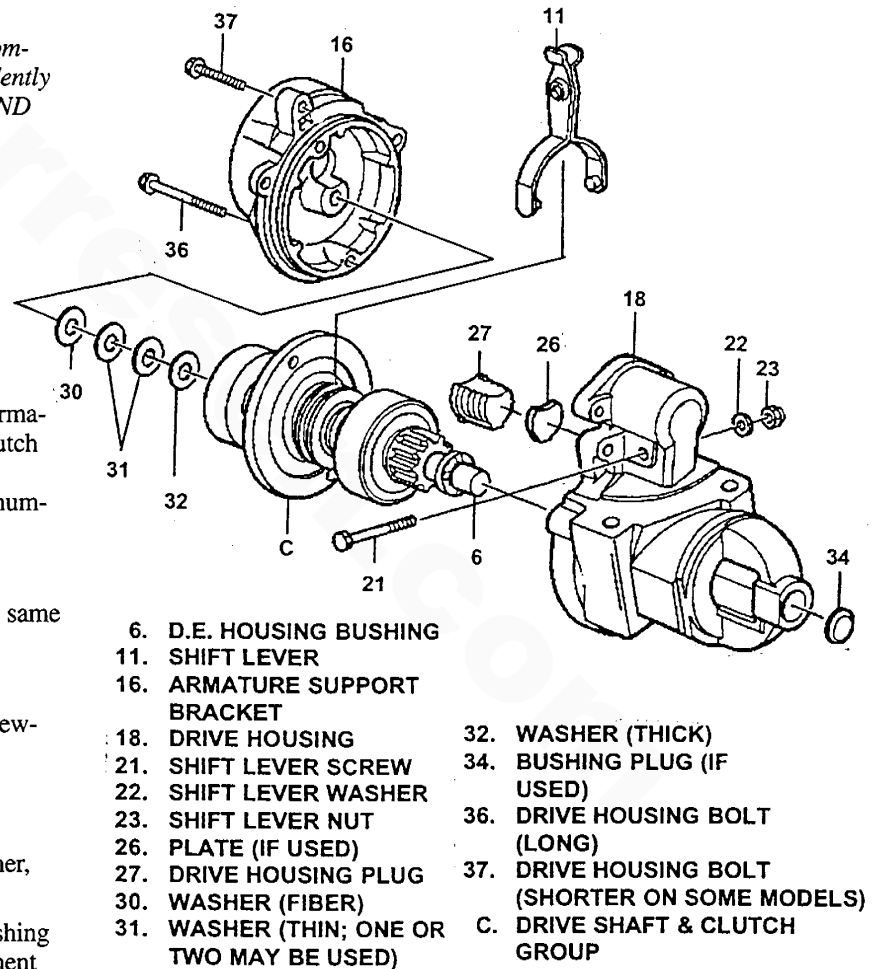

FIGURE 6. GEAR REDUCTION AND DRIVE GROUP



STARTER MOTOR

Disassembly of Drive Shaft and Clutch Group (Figures 7 and 8)

Disassembly of the drive shaft and clutch group is not required unless it is necessary to clean, inspect or replace one or more parts of the group separately. Then proceed as follows:

Remove or disconnect:

1. Stop rings (35) and pinion stop (12).
 - a. Position the drive shaft and clutch group on the work bench with the internal gear end down.
 - b. Using an open tube slightly larger than the shaft (see Figure 8), drive the pinion stop (12) toward the clutch drive assembly (2) until it clears the stop rings (35).
 - c. Using care not to scratch the drive shaft (15), pry the stop rings out of the shaft groove and slide them off the end of the shaft.
 - d. Inspect the edges of the shaft groove for burrs that may have been formed through repeated cranking cycles. Such burrs may make removal of the pinion stop and clutch drive assembly (2) difficult. If burrs are found, use a suitable file to carefully remove the burrs only – not the base metal. Thoroughly clean away metal filings.
 - e. Slide the pinion stop (12) off the drive shaft (15). Discard the old pinion stop (12) and stop rings (35). New parts must be used at assembly.
2. Clutch drive assembly (2) from drive shaft (15).
3. Drive shaft support (17) from drive shaft (15).
 - a. Do not remove the bearing (10) from the drive shaft (15) unless replacement is required (refer to *CLEANING, INSPECTION AND REPAIR*).

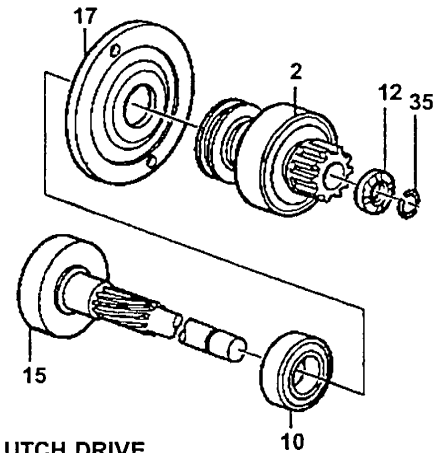

- | | |
|----------------------------|-------------------------|
| 2. CLUTCH DRIVE ASSEMBLY | 15. DRIVE SHAFT |
| 10. CENTER SUPPORT BEARING | 17. DRIVE SHAFT SUPPORT |
| 12. PINION STOP | 35. STOP RINGS (2 PCS) |

FIGURE 7. DRIVE SHAFT AND CLUTCH GROUP

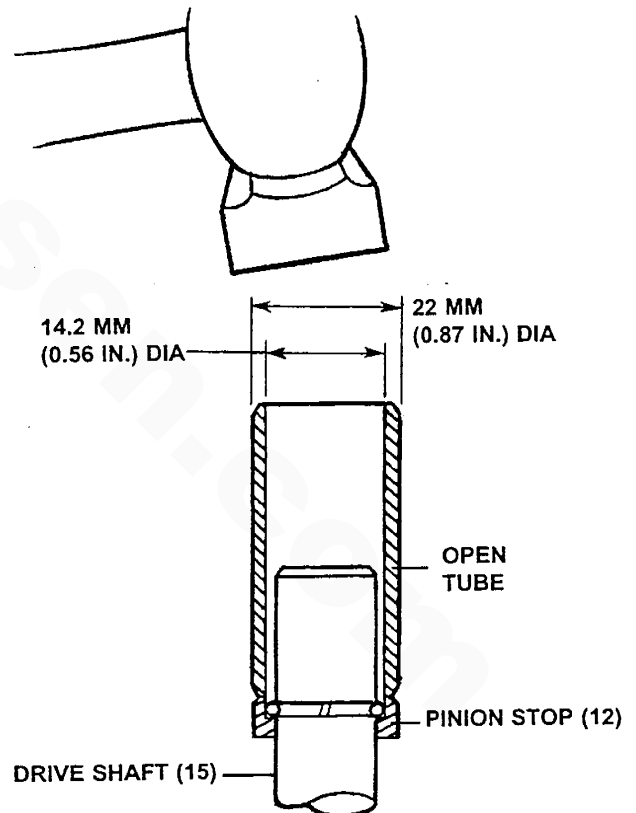

FIGURE 8. REMOVING PINION STOP



STARTER MOTOR

CLEANING, INSPECTION, TESTING AND REPAIR

Cleaning

NOTE: Do not clean or immerse starter parts in grease dissolving solvents. Solvents will dissolve grease packed in the drive assembly and may damage the armature or field coil insulation.

Clean:

1. All starter parts with a soft cloth prior to testing.

Inspection (Figure 3)

Inspection in the following steps refers to visual inspection of the starter parts and assemblies to determine their serviceability. Electrical tests for certain assemblies are described in *COMPONENT ELECTRICAL TESTING*.

Inspect:

1. All parts for cracks, distortion other structural damage. Replace parts or assemblies which are cracked, bent or otherwise damaged.
2. Threaded parts for stripped, crossed or otherwise damaged threads. Replace parts with thread damage that cannot be cleaned up using a suitable tap or die. Replace any hardware items that have damaged threads.
3. The solenoid assembly (1) for a cut or torn boot. If the boot is damaged, replace the solenoid assembly.
4. The clutch drive assembly (2) for the following. Replace the clutch drive assembly if damaged:
 - a. Pinion gear turns roughly or turns in both directions.
 - b. Pinion gear teeth broken or showing evidence of step wear.
 - c. Deep scoring or other damage to the shift lever collar.
5. The brush holder assembly (3) for the following. Replace the brush holder if damaged:
 - a. Loose riveted joints.
 - b. Cracked or broken insulation.
6. Brushes (4 and 5) for excessive wear.
 - a. The minimum allowable brush length is 12 mm (0.472 in.). Replace excessively worn brushes in sets.
7. The D.E. housing bushing (6) for scoring or other damage. Replace a damaged bushing (refer to *REPAIR PROCEDURES*).
8. Ball bearings (8, 9 and 10) as follows:
 - a. Hold the armature (13) or drive shaft (15) and slowly rotate the outer bearing race by hand.
 - b. Check that the bearing turns freely without binding or the feel of flat spots.
 - c. Replace damaged bearings (refer to *REPAIR PROCEDURES*).
9. Armature assembly (13) for the following:
 - a. Gear teeth that are broken, or that show evidence of step wear or root interference.
 - b. Rough commutator surface. Polish with a No. 400 grit polishing cloth if necessary. Thoroughly clean metal dust from between the commutator bars. If the commutator surface cannot be repaired in this manner, replace the armature assembly. Do not turn the commutator in a lathe.
 - c. Worn commutator. Replace the armature assembly if the commutator OD is less than 35 mm (1.378 in.) or if the undercut depth at any point is less than 0.2 mm (0.008 in.). Do not undercut the insulation.
10. Drive shaft (15) for the following. Replace the drive shaft if damaged:
 - a. Scored or damaged shaft where it turns in the bushing (6).
 - b. Internal gear with teeth broken or showing evidence of step wear.
 - c. Damaged spline. The clutch drive assembly must slide smoothly and easily over the full length of the spline.

STARTER MOTOR

Component Electrical Testing (Figures 9 and 10)

Perform the following electrical tests on the solenoid assembly (1), armature assembly (13) and frame and field assembly (19) to determine their serviceability.

1. Using a suitable ohmmeter, check the windings of the solenoid assembly (1) for continuity as follows:
 - a. Check the resistance of the solenoid pull-in and hold-in windings in series by measuring the resistance between the motor terminal (see Figure 9) and the solenoid case. The resistance should be approximately 0.95 ohms for 12-volt starters and approximately 1.75 ohms for 24-volt starters.
 - b. An extremely high resistance reading indicates a break or fault in the winding continuity. A very low resistance reading indicates a short or ground in the winding circuit. Either condition is cause for replacement of the solenoid assembly.
2. Check the armature (13) as follows for shorts, opens or grounds using suitable test equipment and instruments (test lamp must be 110 volts or less).
 - a. Rotate the armature in a growler holding a steel strip such as a hacksaw blade against the armature. If a short circuit is present, the steel strip will vibrate in that area.
 - b. Check the armature for grounds using a test lamp or ohmmeter. There shall be no continuity between the armature shaft and any point on the commutator.
 - c. Check for opens by visually inspecting the points where the armature conductors join the commutator. A poor connection often will be indicated by signs of arcing or burning of the commutator.
 - d. Replace armatures which are shorted, grounded or show evidence of opens.
3. Check frame and field assembly (19) for grounds or opens using a test lamp (110 volts max.) or ohmmeter, as follows:
 - a. Check that there is continuity (no opens) between the field terminal that connects to the solenoid, and the connection points for the insulated brushes on the field coil straps.
 - b. Check that there is no continuity (no grounds) between the frame and the field terminal that connects to the solenoid.
 - c. Replace frame and field assemblies that have grounds or opens.

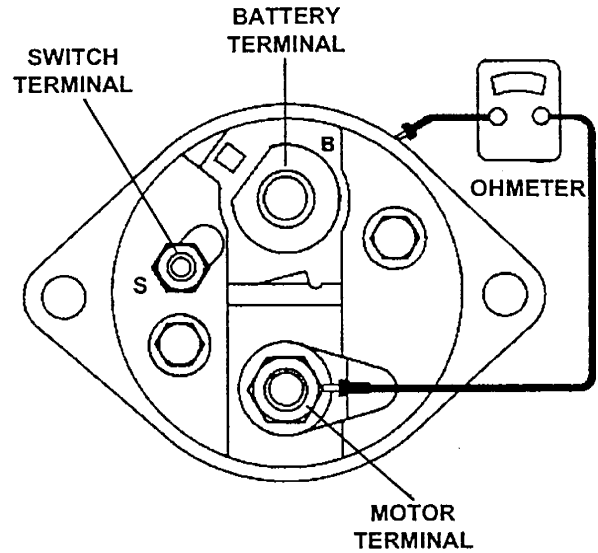

FIGURE 9. SOLENOID TERMINALS

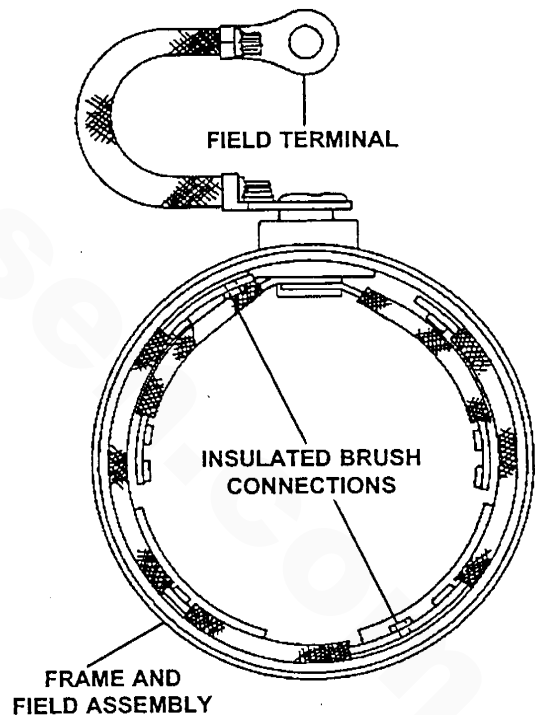

FIGURE 10. FRAME AND FIELD ASSEMBLY

STARTER MOTOR

Repair Procedures (Figures 3 and 11)

1. If necessary, replace the bearings (8 and 9, Figure 3) on the armature (13) as follows:

NOTE: Ball bearings which are removed from the armature must be replaced with new bearings. The removal procedure causes internal damage to the bearings.

Remove or disconnect:

- a. C.E. and/or D.E. bearings (8 and/or 9) from the shaft of the armature (13) using a suitable bearing puller.

Install or Connect:

- b. New C.E. and/or D.E. bearings (8 and/or 9) to the armature assembly (13) using a tube that bears on the bearing's inner race only. Press on the bearing until the inner race bottoms out against the shoulder on the armature shaft.
2. If necessary, replace the center support bearing (10, Figure 3) on the drive shaft (15) as follows:

NOTE: Ball bearings which are removed from the drive shaft must be replaced with new bearings. The removal procedure causes internal damage to the bearings.

Remove or disconnect:

- a. The center support bearing (10) from the drive shaft (15) using a locally fabricated tool as shown in Figure 11.

Install or Connect:

- b. The center support bearing (10) from the drive shaft (15) using a locally fabricated tool (Figure 11). With the drive shaft in a suitable support fixture, place the tool bolt ends through the access holes in the wide end of the drive shaft and squarely press the bearing off of the surface on the center shaft.
3. If necessary, replace the bushing (6, Figure 3) in the drive housing (18) as follows:
 - a. From inside the drive housing (18), drive out the plug (34) if present. Use a file to clean away remnants of the old stake to allow installation of a new plug. Clean away any metal shavings.
 - b. Using a suitable open tube, press out the bushing (6).
 - c. Using a suitable open tube, press the new bushing (6) into the drive housing (18) until the end of the bushing is flush with the inside of the housing.
 - d. Install a new plug (34), if used, to the drive housing. Stake housing material over the plug at three places, equally spaced.

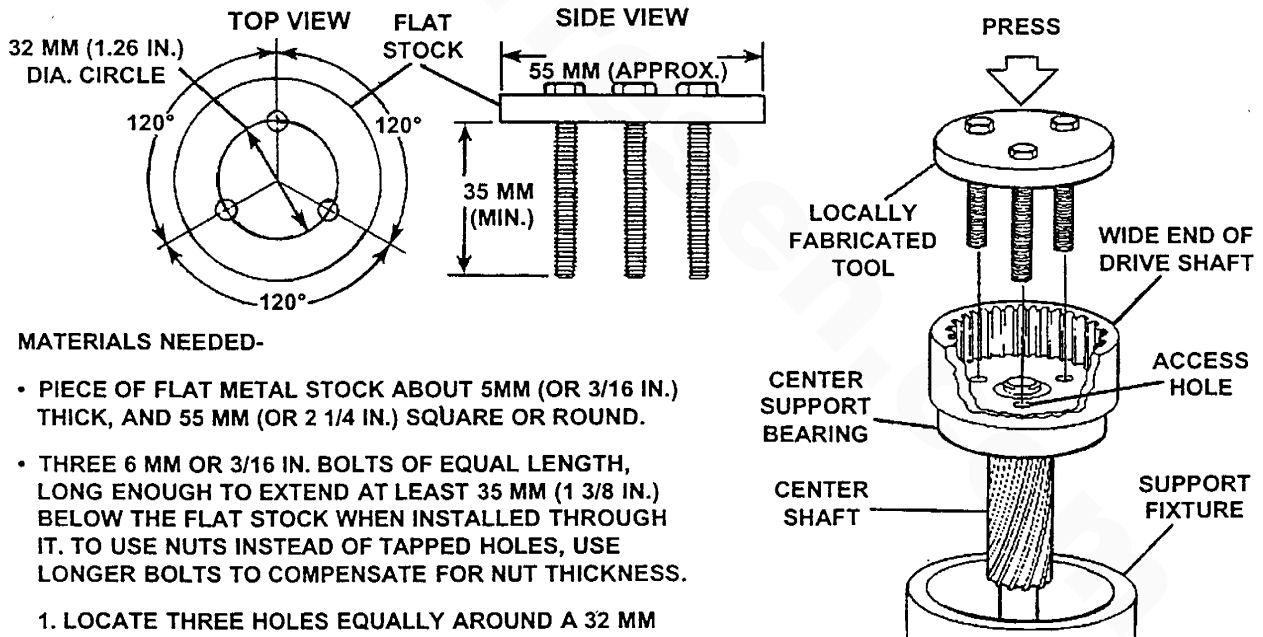

MATERIALS NEEDED-

- PIECE OF FLAT METAL STOCK ABOUT 5MM (OR 3/16 IN.) THICK, AND 55 MM (OR 2 1/4 IN.) SQUARE OR ROUND.
- THREE 6 MM OR 3/16 IN. BOLTS OF EQUAL LENGTH, LONG ENOUGH TO EXTEND AT LEAST 35 MM (1 3/8 IN.) BELOW THE FLAT STOCK WHEN INSTALLED THROUGH IT. TO USE NUTS INSTEAD OF TAPPED HOLES, USE LONGER BOLTS TO COMPENSATE FOR NUT THICKNESS.

1. LOCATE THREE HOLES EQUALLY AROUND A 32 MM (1.26 IN.) CIRCLE ON FLAT STOCK. DRILL AND TAP HOLES AS NEEDED TO MATCH BOLT THREADS.
2. INSTALL BOLTS IN FLAT STOCK AND TIGHTEN. ENDS OF INSTALLED BOLTS SHOULD PASS THROUGH ACCESS HOLES IN END OF DRIVE SHAFT WITHOUT BINDING.

FIGURE 11. TOOL FOR REMOVING CENTER SUPPORT BEARING



STARTER MOTOR

ASSEMBLY

Lubrication During Assembly

1. The armature bearings (8 and 9, Figure 3) and drive shaft support bearing (10) are permanently lubricated. Do not add lubricant to these bearings. Lubricate the following just before or during assembly (avoid excessive grease):
 - a. D.E. housing bushing (6) (in drive housing).
 - b. The pivot hole and working surface on the ends of the shift lever (11).
 - c. The internal gear, shaft and spline on the drive shaft (15).

Drive Shaft and Clutch Group (Figures 7 and 12)

1. If disassembled, position the drive shaft on the work surface with the internal gear end down and assemble the drive shaft and clutch group as follows:

Important:

- a. If the center support bearing (10) is being replaced, install it on the drive shaft (15) as specified in *REPAIR PROCEDURES*, step 2, before proceeding with assembly.

Install or Connect:

1. The drive shaft support (17) to the drive shaft (15), seating the bearing (10) in the support.
2. The clutch drive assembly (2) to the drive shaft (15).
3. A new pinion stop (12) onto the drive shaft (15), the end with the recess for the stop rings (35) up.
 - a. Install the stop rings (35) in the groove in the drive shaft (15).
 - b. Pick up and support the assembly under the pinion stop (12). A metal block, with a U-shaped cutout that will slide over the shaft between the pinion gear and the stop, can be clamped in a vise to provide support (see Figure 12).
 - c. Make sure the stop rings (35) (in the drive shaft groove) are fully seated in the pinion stop recess and stake the upper edge of the pinion stop (12) over the stop ring (35) at four places, equally spaced. Do not allow staked metal to contact the drive shaft (15).

Assembly of Gear Reduction and Drive Group (Figure 6)

Important:

If the D.E. bushing (6) and plug (34) are being replaced, install them in the drive housing (18) as specified in *REPAIR PROCEDURES*, step 3, before proceeding with assembly.

1. Lubricate the D.E. housing bushing, shift lever, and drive shaft as described under *LUBRICATION DURING ASSEMBLY*.

Install or Connect:

2. The arms on the shift lever (11) with the shift collar on the drive shaft and clutch group (C).
3. The assembled shift lever (11) and the drive shaft and clutch group (C) into the drive housing (18), aligning the holes in the drive shaft support (17, Figure 7) with those in the drive housing.
 - a. Make sure that the drive shaft support is fully seated in the drive housing and that the drive shaft bearing (10, Figure 7) remains fully seated in the drive shaft support.
4. Shift lever screw (21), washer (22) and nut (23).

Tighten:

- a. Nut to 4.5 Nm (40 lb-in.).
5. The plate (26), if used, and the drive housing plug (27) to the drive housing (18).
6. Washers (30 through 32) in the same number and positions as noted at disassembly.
7. The armature support bracket (16) to the drive housing (18), aligning the mark made prior to disassembly with that on the drive housing.
8. Drive housing bolts (36 and 37).

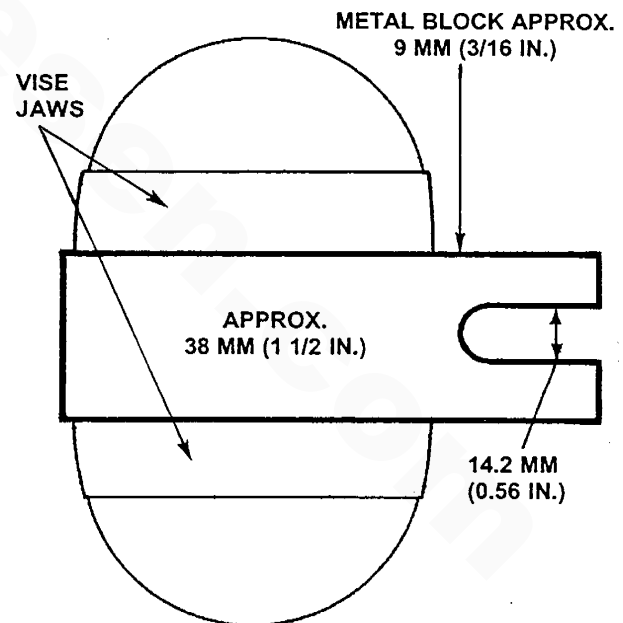

FIGURE 12. PINION STOP SUPPORT BLOCK

STARTER MOTOR

Assembly of Frame, Field and Brush Holder Group (Figures 5, 13 and 14)

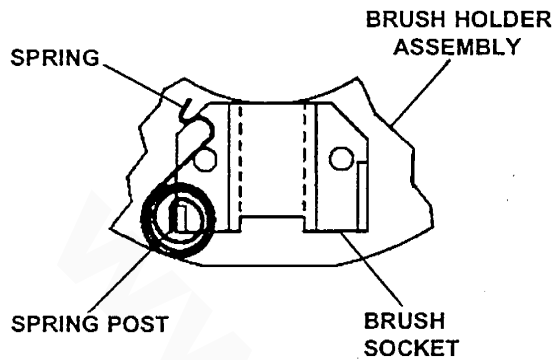

FIGURE 13. BRUSH SPRING ON POST

Install or Connect:

1. Brush springs (7), if removed.
 - a. Start each brush spring onto the post on the brush holder assembly (3) as shown in Figure 13, just enough to hold the inside end of the spring from turning.
 - b. Grasp the free end of the spring with needle nose pliers and twist clockwise over the top of the brush socket.
 - c. Push the spring fully onto the post and release the free end to engage the notch in the brush socket.

NOTE: The brush leads may be damaged by excessive handling. Do not over-flex the leads near the clip welds or the clips may break off.

2. Brushes (4 and 5), if removed.
 - a. See Figure 14 for the proper installed position of all brushes. Make sure the insulated brushes (5) go into the brush sockets of the brush holder assembly (3) that are mounted on the insulation.
 - b. To install each brush, grasp the free end of the brush spring with needle nose pliers, twist clockwise to clear the brush socket and insert the brush partly into the brush socket.
 - c. Gradually release the spring so that its end contacts the side (not end) of the brush (see Figure 13). This will hold the brushes retracted until after the brush holder is installed over the armature commutator.
3. Grounded brush screws (39).
 - a. Position the terminals of the grounded brush leads behind the terminal tabs on the brush holder (3) (see Figure 13).
 - b. Insert the brush screws (39) through the terminal tabs on the brush holder and thread them into the brush lead terminals.

Tighten:

- c. Grounded brush screws to 1.5 Nm (13 lb-in.).

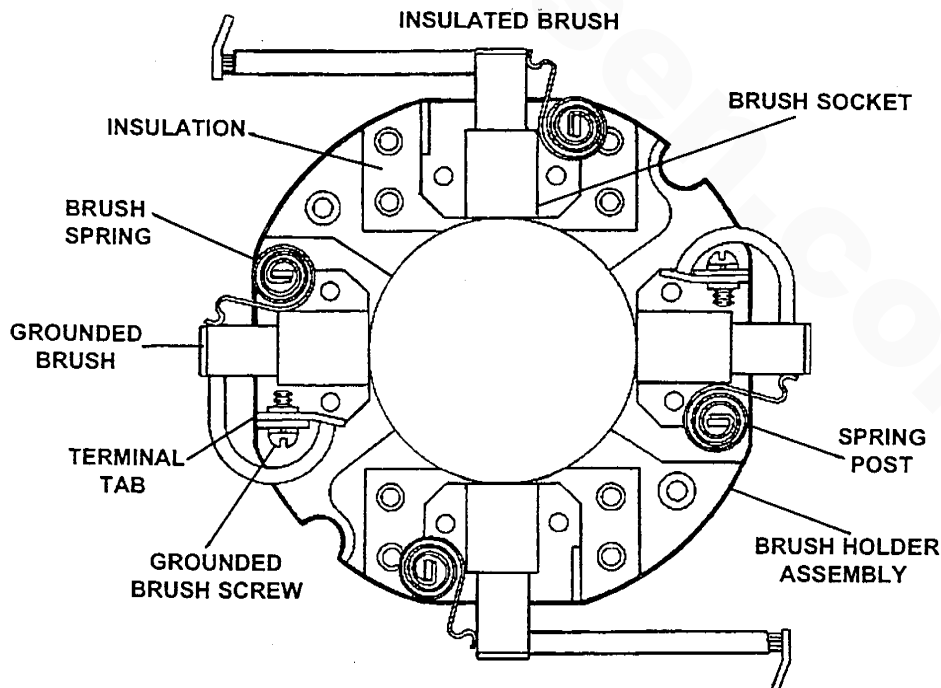

FIGURE 14. SPRINGS AND BRUSHES ON BRUSH HOLDER



STARTER MOTOR

4. The frame and field assembly (19) to the brush holder assembly.
 - a. Position the brush holder assembly (3) (with installed brushes) over the terminal end of the frame and field assembly (19).
 - b. Attach the terminals of the insulated brush leads to the conductors in the frame and field assembly with the insulated brush screws (29).

Tighten:

- c. The insulated brush screws to 1.5 Nm (13 lb-in.).

Starter Assembly (Figures 4 and 15)

Support the gear reduction and drive group (B) with the pinion gear end down and proceed as follows:

Important:

If the armature bearings (8 and 9) are being replaced, install them on the armature (13) as specified in REPAIR PROCEDURES, step 1 before proceeding with assembly.

Install or Connect:

1. Solenoid assembly (1).
 - a. Pivot the plunger of the solenoid assembly into engagement with the shift lever in the gear reduction and drive group (B).
 - b. Position the solenoid assembly mounting flange and install the solenoid mounting screws (25).

Tighten:

- c. Solenoid screws to 2.8 Nm (25 lb-in.).
2. Frame seal (33).
3. The armature assembly (13) with bearings (8 and 9) into the gear reduction and drive group (B).
 - a. Make sure the gear teeth are aligned, then seat the bearing (8) on the armature shaft fully into the housing recess.
4. Frame, field and brush holder group (A).
 - a. Place the dowel pin (28) in the hole in the armature support bracket of the gear reduction and drive group (B).
 - b. Position the frame, field and brush holder group over the armature assembly (13), align the hole for the dowel pin (28) and the marks made prior to disassembly, and seat in the gear reduction and drive group (B).
 - c. Twist the brush springs (7, Figure 5) away from the brushes (4 and 5, Figure 5), slide the brushes in to contact the commutator on the armature (13), and release the brush springs to contact the ends of the brushes.
5. O-ring (20).

Important:

- a. The O-ring can easily be damaged during installation of the C.E. frame (14). To prevent such damage, install the O-ring as described in the following steps.
 - b. Install the O-ring on the frame, field and brush holder group (A) so that it is against the shoulder on the field frame that will abut the C.E. frame when installed. This is the normal installed position for the O-ring.
 - c. Carefully roll the O-ring out of its normal installed position up onto the major O.D. of the field frame. Allow the O-ring to remain in this position until the C.E. frame is partially installed.
6. C.E. frame (14).
 - a. Align the marks on the C.E. frame and frame and field assembly (19, Figure 5) made prior to disassembly.
 - b. Start the C.E. frame onto the frame and field assembly, leaving a gap just slightly larger than the thickness of the O-ring (20).
7. Brush plate screw (42).
 - a. Use a scribe or similar tool to align the tapped holes in the brush holder assembly (3, Figure 5) with the screw holes in the C.E. frame (14).

Tighten:

- b. Brush plate screws to 2.8 Nm (25 lb-in.).
8. Thru bolts (41).
 - a. Install the thru bolts and tighten them by hand but do not close the gap between the C.E. frame and the frame and field assembly where the O-ring (20) goes.
 - b. Roll the O-ring (20) back down into its installed position between the C.E. frame and the frame and field assembly.
 - c. Align the timing ribs on the edge of the C.E. frame (14) with the timing spots on the frame and field assembly (A) to assure proper brush alignment. Refer to Figure 15. Marks are located in 2 places on the motor but will only match one way.

Tighten:

- d. Thru bolts (41) to 8.5 Nm (75 lb-in.).
9. The motor lead on the frame and field assembly (19, Figure 5).
 - a. Remove the nut from the terminal on the solenoid, install the motor lead terminal and reinstall the nut.

Tighten:

- b. The nut on the terminal of the solenoid assembly to 11 Nm (100 lb-in.).



STARTER MOTOR

STARTER INSTALLATION

Testing After Repair or Overhaul

After repair or overhaul, the starter can be tested as specified in the Starter No-Load Test found in the *TROUBLESHOOTING* section.

After repair, overhaul, testing or replacement of the starter, reinstall it using the following torques when making the electrical connections to the starter.

CAUTION: Make sure the negative battery cable is disconnected at the battery when making the electrical connections to the starter. Otherwise, injury may result. If a tool is shorted at the solenoid battery terminal, the tool will heat enough to cause a skin burn.

Tighten:

- a. Solenoid battery (B) terminal nut to 18 Nm (13 lb-ft).
- b. Solenoid switch (S) terminal nut to 1.8 Nm (16 lb-in.).

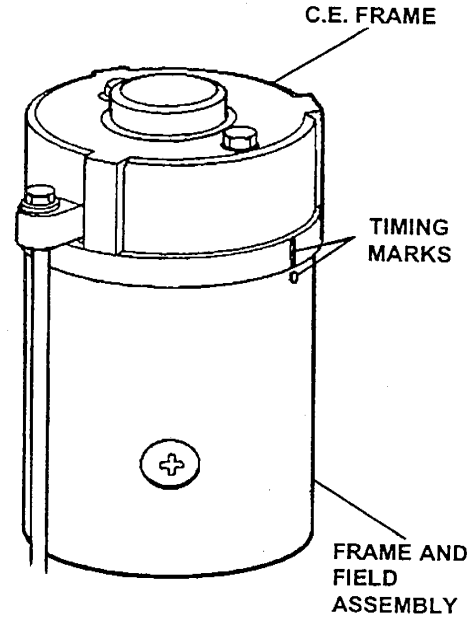

FIGURE 15. ALIGNING TIMING MARKS

STARTER SPECIFICATIONS

All 12 Volt models have these No-Load Test Specifications:

VOLTS	AMPS		RPM	
	Minimum	Maximum	Minimum	Maximum
10	125	190	3000	5600

All 24 Volt models have these No-Load Test Specifications:

VOLTS	AMPS		RPM	
	Minimum	Maximum	Minimum	Maximum
20	75	90	3600	5400

Starter Solenoid current consumption:

RATED VOLTAGE	PULL IN WINDING			HOLD IN WINDING		
	AMPS	VOLTS	OHMS	AMPS	VOLTS	OHMS
12	52 - 59	10	0.17 - 0.19	12 - 14	10	0.76 - 0.81
24	100 - 125	20	0.16 - 0.20	12 - 14	20	1.15 - 1.65



ADMIRAL CONTROL PANEL

DESCRIPTION

This manually-operated control panel is equipped with a KEY switch and RPM gauge with an ELAPSED TIME meter which measures the engine's running time in hours and in 1/10 hours. The panel also includes a WATER TEMPERATURE gauge which indicates water temperature in degrees Fahrenheit, an OIL PRESSURE gauge which measures the engine's oil pressure in pounds per square inch, and a DC control circuit VOLTAGE gauge which measures the system's voltage. All gauges are illuminated when the key switch is turned on and remain illuminated while the engine is in operation. The panel also contains two rubber-booted pushbuttons, one for PREHEAT and one for START.

When the engine is shut down with the key switch turned off, the water temperature gauge will continue to register the last temperature reading indicated by the gauge before electrical power was turned *off*. The oil pressure gauge will fall to zero when the key switch is turned *off*. The temperature gauge will once again register the engine's true temperature when electrical power is restored to the gauge.

A separate alarm buzzer with harness is supplied with every Admiral Panel. The installer is responsible for electrically connecting the buzzer to the four-pin connection on the engine's electrical harness. The installer is also responsible for installing the buzzer in a location where it will be dry and where it will be audible to the operator should it sound while the engine is running. The buzzer will sound when the ignition key is turned on and should silence when the engine has started and the engine's oil pressure rises above 15 psi (1.1 kg/cm²).

WATER TEMPERATURE GAUGE: THIS GAUGE IS GRADUATED IN DEGREES FAHRENHEIT AND IS ILLUMINATED WHILE THE KEY SWITCH IS TURNED ON. THE ENGINE'S NORMAL OPERATING TEMPERATURE IS 170° - 190° F (77° - 88°C).

OIL PRESSURE GAUGE: THIS GAUGE IS GRADUATED IN POUNDS PER SQUARE INCH (PSI) AND IS ILLUMINATED WHILE THE KEY SWITCH IS TURNED ON. THE ENGINE'S NORMAL OPERATING OIL PRESSURE RANGES BETWEEN 30 - 60 psi (2.1 - 4.2 kg/cm²).

RPM GAUGE: REGISTERS REVOLUTIONS PER MINUTE OF THE ENGINE AND CAN BE RECALIBRATED FOR ACCURACY FROM THE REAR OF THE PANEL.

HOURLY METER: REGISTERS ELAPSED TIME, AND SHOULD BE USED AS A GUIDE FOR THE MAINTENANCE SCHEDULE.

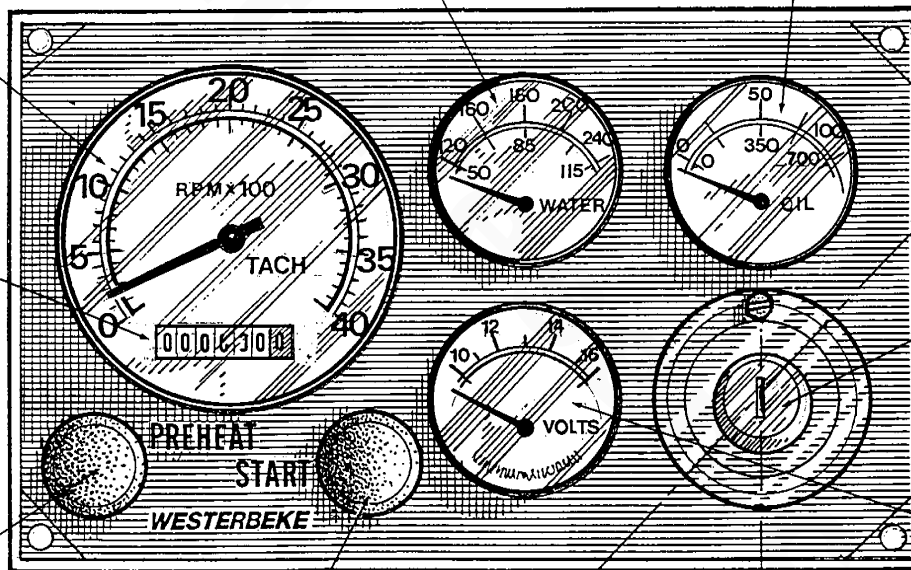

KEY SWITCH: PROVIDES POWER ONLY TO THE INSTRUMENT PANEL CLUSTER.

DC VOLTMETER: INDICATES THE AMOUNT THE BATTERY IS BEING CHARGED. SHOULD SHOW 13V TO 14V.

PREHEAT BUTTON: WHEN PRESSED, ENERGIZES THE ALTERNATOR'S EXCITER, THE FUEL LIFT PUMP, THE FUEL SOLENOID ON THE INJECTION PUMP, AND THE ENGINE'S AIR INTAKE HEATER. IT BYPASSES THE ENGINE'S OIL PRESSURE ALARM SWITCH. IN ADDITION, THIS BUTTON ENERGIZES THE START BUTTON.

START BUTTON: WHEN PRESSED, ENERGIZES THE STARTER'S SOLENOID WHICH CRANKS THE ENGINE. THIS BUTTON WILL NOT OPERATE ELECTRICALLY UNLESS THE PREHEAT BUTTON IS PRESSED AND HELD AT THE SAME TIME.

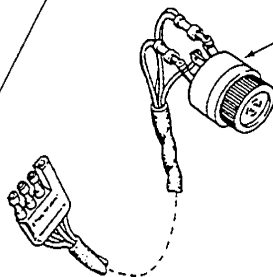

AUTOMATIC ALARM SYSTEM

COOLANT TEMPERATURE ALARM: AN ALARM BUZZER HAS BEEN SUPPLIED WITH THE INSTRUMENT PANEL. IF THE ENGINE'S COOLANT REACHES 210° F (99°C), THIS SWITCH WILL CLOSE SOUNDING THE ALARM WHICH WILL EMIT A *CONTINUOUS* SIGNAL.

OIL PRESSURE ALARM: AN OIL PRESSURE ALARM SWITCH IS LOCATED OFF THE ENGINE'S OIL GALLERY. THIS SWITCH MONITORS THE ENGINE'S OIL PRESSURE. SHOULD THE ENGINE'S OIL PRESSURE FALL TO 5 - 10 psi (0.4 - 0.7 kg/cm²), THE SWITCH WILL CLOSE SOUNDING THE ALARM. IN THIS EVENT, THE ALARM WILL EMIT A *PULSATING* SIGNAL.



CAPTAIN CONTROL PANEL

DESCRIPTION

This manually-operated control panel is equipped with a KEY switch, an RPM gauge, PREHEAT and START buttons, an INSTRUMENT TEST button and three indicator lamps, one for ALTERNATOR DISCHARGE, one for low OIL PRESSURE, and one for high ENGINE COOLANT TEMPERATURE. It also includes an alarm buzzer for low

OIL PRESSURE or high COOLANT TEMPERATURE. The RPM gauge is illuminated when the KEY switch is turned on and remains illuminated while the engine is in operation.

RPM GAUGE: REGISTERS REVOLUTIONS PER MINUTE OF THE ENGINE AND CAN BE RECALIBRATED FOR ACCURACY FROM THE REAR OF THE PANEL.

ALARM: THE ALARM WILL SOUND IF THE ENGINE'S OIL PRESSURE FALLS BELOW 5 - 10 psi (0.4 - 0.7 kg/cm²). IN THIS EVENT, THE ALARM WILL EMIT A PULSATING SIGNAL. THE ALARM WILL ALSO SOUND IF THE COOLANT TEMPERATURE IN THE FRESHWATER COOLING CIRCUIT RISES TO 210°F (99°C). IN THIS EVENT, THE ALARM WILL EMIT A CONTINUOUS SIGNAL.
NOTE: THE ALARM WILL SOUND WHEN THE KEY SWITCH IS TURNED ON. THIS SOUNDING IS NORMAL. ONCE THE ENGINE STARTS AND THE ENGINE'S OIL PRESSURE REACHES 15 psi (1.1 kg/cm²), THE ALARM WILL SILENCE.

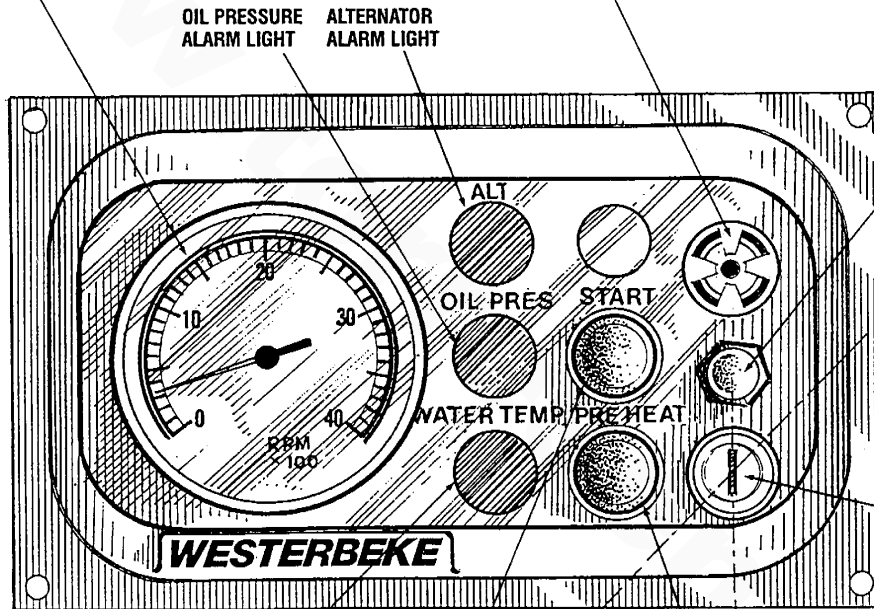

TEST BUTTON: WHEN PRESSED, TESTS THE ALTERNATOR, THE OIL PRESSURE, AND THE COOLANT TEMPERATURE CONTROL CIRCUITS. WHEN PRESSED, THE ALTERNATOR, THE OIL PRESSURE, AND THE WATER TEMPERATURE INDICATOR LIGHTS ILLUMINATE IN ADDITION TO SOUNDING THE ALARM BUZZER.

KEY SWITCH: PROVIDES POWER ONLY TO THE INSTRUMENT PANEL CLUSTER.

START BUTTON: WHEN PRESSED, ENERGIZES THE STARTER'S SOLENOID WHICH CRANKS THE ENGINE. THIS BUTTON WILL NOT OPERATE ELECTRICALLY UNLESS THE PREHEAT BUTTON IS PRESSED AND HELD AT THE SAME TIME.

PREHEAT BUTTON: WHEN PRESSED, ENERGIZES THE ALTERNATOR'S EXCITER, THE FUEL LIFT PUMP, THE FUEL SOLENOID ON THE INJECTION PUMP, AND THE ENGINE'S AIR INTAKE HEATER, AND BYPASSES THE ENGINE'S OIL PRESSURE ALARM SWITCH. IN ADDITION, THIS BUTTON ENERGIZES THE START BUTTON.



CONTROL PANEL TROUBLESHOOTING

TACHOMETER/HOURMETER

The tachometer/hourmeter used in propulsion engine instrument panels contains two separate electrical circuits with a common ground. One circuit operates the hourmeter and the other the tachometer. The hourmeter circuit operates on 12 volts alternator charging voltage supplied to the (+) terminal on the back of the instrument.

The tachometer circuit operates on AC voltage 6-8 volts, fed from one of the diodes in the alternator and supplied to the tachometer input terminal while the engine is running, and the alternator producing battery charging voltage 13.0-14.8 volts DC.

The following are procedures to follow when troubleshooting a fault in either of the two circuits in a tachometer/hourmeter.

Hourmeter Inoperative

Check for the proper DC voltage between (+) and (-) terminals.

1. Voltage present - meter is defective - repair or replace.
2. Voltage not present - trace (+) and (-) electrical connections for fault. (Jump 12 volts DC to meter (+) terminal to verify the operation.)

Tachometer Inoperative

Check for the proper AC voltage between tachometer input terminal and (-) terminal with the engine running.

1. Voltage present - attempt adjusting meter through calibration access hole. No results, repair or replace meter.
2. AC voltage not present - check for proper alternator DC output voltage.
3. Check for AC voltage at tach terminal on alternator to ground.
4. Check electrical connections from tachometer input terminal to alternator connection.

Tachometer Sticking

1. Check for proper AC voltage between "tach inp." terminal and (-) terminal.
2. Check for good ground connection between meter (-) terminal and alternator.
3. Check that alternator is well grounded to engine block at alternator pivot bolt.

Tachometer Inaccurate

- a. With a hand-held tach on the front of the crankshaft pulley retaining nut or with a strobe-type tach, read the front crankshaft pulley rpm at idle.
- b. Adjust the tachometer with a small Phillips type screwdriver through the calibration access hole in the rear of the tachometer. Zero the tach and bring it to the rpm indicated by the strobe or hand tach. (Verify the rpm at idle and at high speed 3000-3600 rpm). (Adjust the tach as needed.)

NOTE: Current model tachometers use a coarse adjustment dial to set the tachometer to the crankshaft pulley rpms. The calibrating screw is then used for fine tuning.

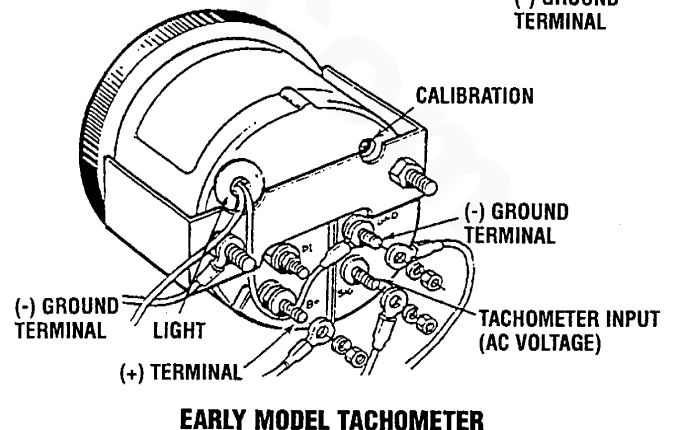
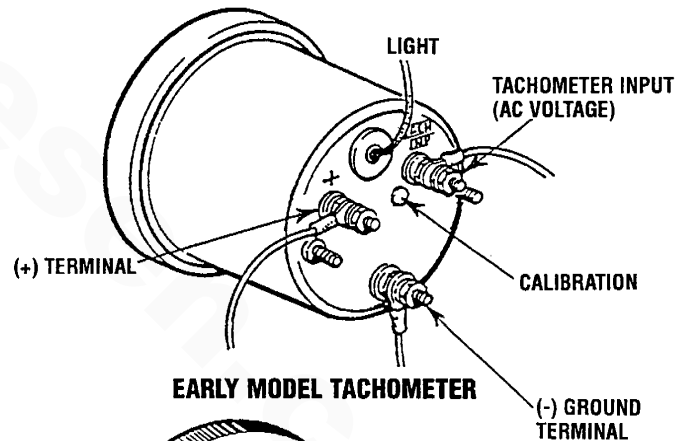
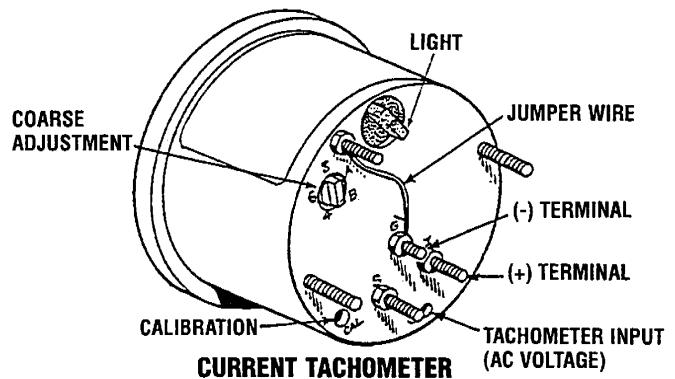

DC ELECTRICAL SYSTEM

12 VOLT DC CONTROL CIRCUIT

The engine has a 12 volt DC electrical control circuit that is shown on the wiring diagrams that follow. Refer to these diagrams when troubleshooting or when servicing the DC electrical system.

CAUTION: To avoid damage to the battery charging circuit, never shut off the engine battery switch while the engine is running. Shut off the engine battery switch, however, to avoid electrical shorts when working on the engine's electrical circuit.

BATTERY

The minimum recommended capacity of the battery used in the engine's 12 volt DC control circuit is 600 – 900 Cold Cranking Amps (CCA).

Battery Care

Review the manufacturer's recommendations and then establish a systematic maintenance schedule for your engine's starting batteries and house batteries.

- Monitor your voltmeter for proper charging during engine operation.
- Check the electrolyte level and specific gravity with a hydrometer.
- Use only distilled water to bring electrolytes to a proper level.
- Make certain that battery cable connections are clean and tight to the battery posts (and to your engine).
- Keep your batteries clean and free of corrosion.

WARNING: Sulfuric acid in lead batteries can cause severe burns on skin and damage clothing. Wear protective gear.

AIR INTAKE HEATER

The air heater consists of a small heating coil located just inboard of the air intake silencer housing. The coil heats the engine intake air. It is wired through the preheat solenoid. When PREHEAT is pressed at the control panel, this solenoid will "click" on and the heating coil will begin to get hot.

CAUTION: Do not keep the air heater on for more than 30 seconds.

No maintenance is required for the air heater.

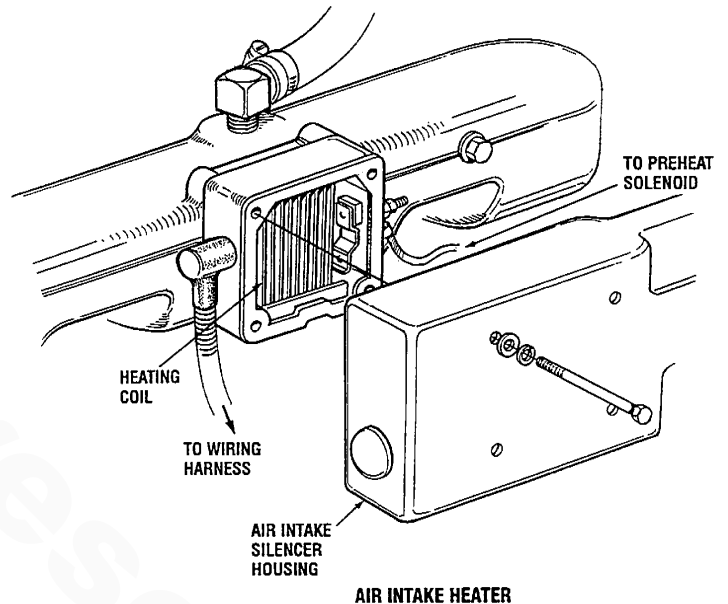

ALTERNATOR

DESCRIPTION

The charging system consists of a DC belt driven alternator with a voltage regulator, an engine DC wiring harness, a mounted DC circuit breaker and a battery with connecting cables. Because of the use of integrated circuits (IC's), the electronic voltage regulator is very compact and is mounted internally or on the back of the alternator.

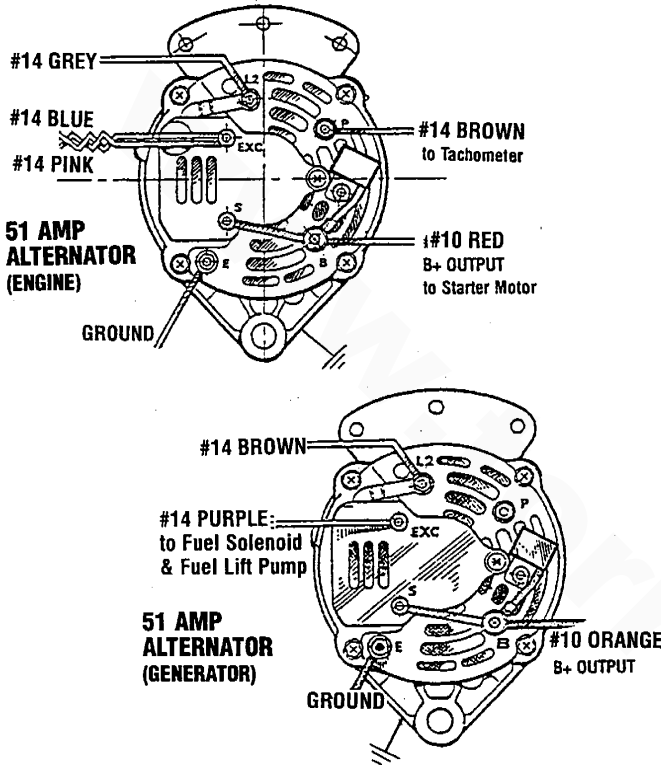

ALTERNATOR TROUBLESHOOTING

WARNING: A failed alternator can become very hot. Do not touch until the alternator has cooled down.

Use this troubleshooting section to determine if a problem exists with the charging circuit or with the alternator. If it is determined that the alternator or voltage regulator is faulty, have a qualified technician check it.

The alternator charging circuit charges the starting battery and the service battery. An isolator with a diode, a solenoid or a battery selector switch is usually mounted in the circuit to isolate the batteries so the starting battery is not discharged along with the service battery. If the alternator is charging the starting battery but not the service battery, the problem is in the service battery's charging circuit and not with the alternator.

Testing the Alternator

CAUTION: Before starting the engine make certain that everyone is clear of moving parts! Keep away from sheaves and belts during test procedures.

WARNING: When testing with a multimeter: DC and AC circuits are often mixed together in marine applications. Always disconnect a shore power cord, isolate DC and AC converters, and shut down the engine before performing DC testing. No AC tests should be made without a proper knowledge of AC circuits.

1. Start the engine.
2. After the engine has run for a few minutes, measure the starting battery voltage at the battery terminals using a multimeter set on DC volts.
 - a. If the voltage is increasing toward 14 volts, the alternator is working; omit Steps 3 through 8 and go directly to *Checking the Service Battery* on the next page.
 - b. If the voltage remains around 12 volts, a problem exists with either the alternator or the charging circuit; continue with Steps 3 through 8.

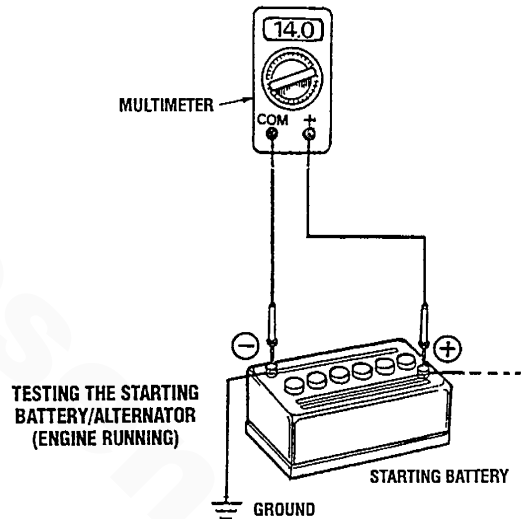

3. Turn off the engine. Inspect all wiring and connections. Ensure that the battery terminals and the engine ground connections are tight and clean.

CAUTION: To avoid damage to the battery charging circuit, never shut off the engine battery switch when the engine is running!

4. If a battery selector switch is in the charging circuit, ensure that it is on the correct setting.
5. Turn on the ignition switch, but do not start the engine.
6. Check the battery voltage. If the battery is in good condition, the reading should be 12 to 13 volts.



ALTERNATOR

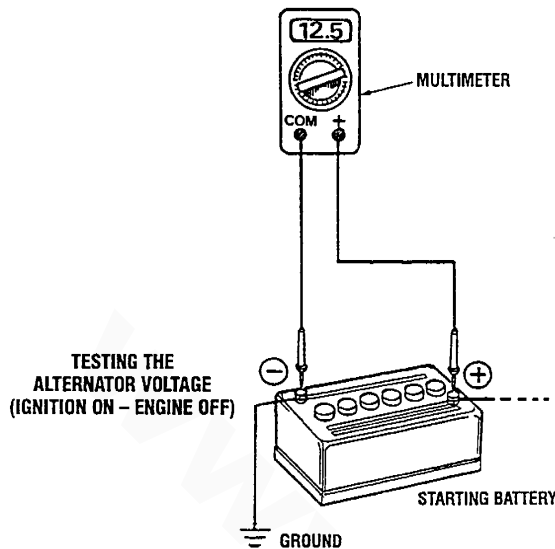

7. Now check the voltage between the alternator output terminal (B+) and ground. If the circuit is good, the voltage at the alternator will be the same as the battery, or if an isolator is in the circuit the alternator voltage will be zero. If neither of the above is true, a problem exists in the circuit between the alternator and the battery. Check all the connections — look for an opening in the charging circuit.

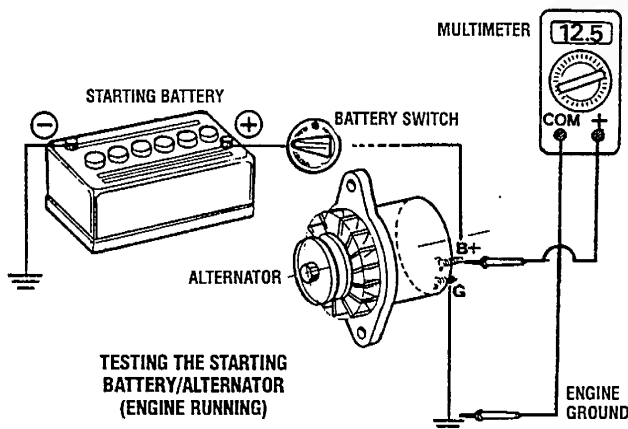

8. Start the engine again. Check the voltage between the alternator output and ground.
- The voltage reading for a properly operating alternator should be between 13.5 and 14.5 volts. If your alternator is over- or under-charging, have it repaired at a reliable service facility.
- NOTE:** Before removing the alternator for repair, use a voltmeter to ensure that 12 volts DC excitation is present at the EXC terminal if the previous test showed only battery voltage at the B output terminal.

If 12 volts is not present at the EXC terminal, trace the wiring and look for breaks and poor connections.

Jump the 12 V to the Exc. terminal from a known 12V source and operate the alternator. If the voltage output is 13-14 volts, the alternator is o.k. Trace the cause for 12 volts not present at the Exc. terminal.

Checking the Service Battery

Check the voltage of the service battery. This battery should have a voltage between 13 and 14 volts when the engine is running. If not, there is a problem in the service battery charging circuit. Troubleshoot the service battery charging circuit by checking the wiring and connections, the solenoid, isolator, battery switch, and the battery itself.

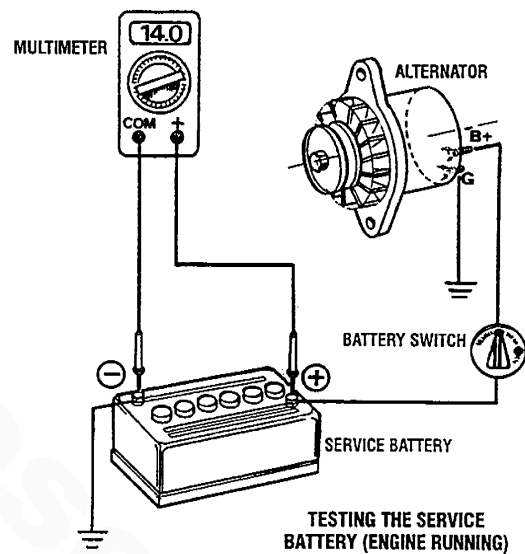

CAUTION: To avoid damaging the alternator diodes, do not use a high voltage tester (i.e. a megger) when performing tests on the alternator charging circuit.

ALTERNATOR INSPECTION

When rebuilding the engine, the alternator should be cleaned and inspected. The housing can be wiped off with a solvent and the alternator terminal studs should be cleaned with a wire brush. Make certain the studs are tight and clean the wiring connections that connect to the wiring harness.

Turn the rotor pulley by hand. It should turn smoothly.

Depending on when the alternator was last serviced, the brushes may need replacing. If the alternator is at all suspect, send it to a service shop for testing and overhaul.

DUAL OUTPUT ALTERNATORS

DESCRIPTION

Dual output and high output alternators are available as optional equipment on most WESTERBEKE engines. These alternators can be installed during factory assembly or as add-on equipment at anytime.

Dual alternators can be configured to charge two banks of batteries at the same time or, using a battery selector switch, charge each set of batteries separately.

INSTALLATION

If an optional dual alternator has already been factory installed, simply follow the WESTERBEKE wiring diagram and the engine installation instructions.

If the new dual alternator is being added to an existing "in-the-boat" engine, carefully follow the alternator installation instructions below:

1. Disconnect the alternators negative cable from the battery.
2. Remove the alternator and disconnect or tape off the output [positive] cable. Do not reuse.
3. Install the new alternator.
4. Attach a new heavy gauge output cable[s] from the alternator's output terminal [s]. Using the cable sizes indicated.

LENGTH REQUIRED	UP TO 6'	#4 WIRE
	UP TO 12'	#2 WIRE
	UP TO 20'	#0 WIRE

[ALWAYS USE FINE STRAND CABLE]

5. Make certain that the batteries negative post ground cable to the engine block is the same heavy gauge as the positive cable.
6. Mount the regulator to a flat surface in a cool dry location.
 - a. Connect the black wire to the ground terminal on the alternator.

CAUTION: Do not connect any power source without first grounding the regulator.

- b. Plug the 2-pin connector into the alternator, make certain it is firmly seated.
- c. The red "battery sense" wire should be connected to the batteries positive [+] post [or the positive cable].
- d. The brown wire "keyed ignition" is the key circuit which actuates the regulator, this wire must connect to a switched [+] 12 volt source. Refer to the WESTERBEKE WIRING DIAGRAM for the proper connection.

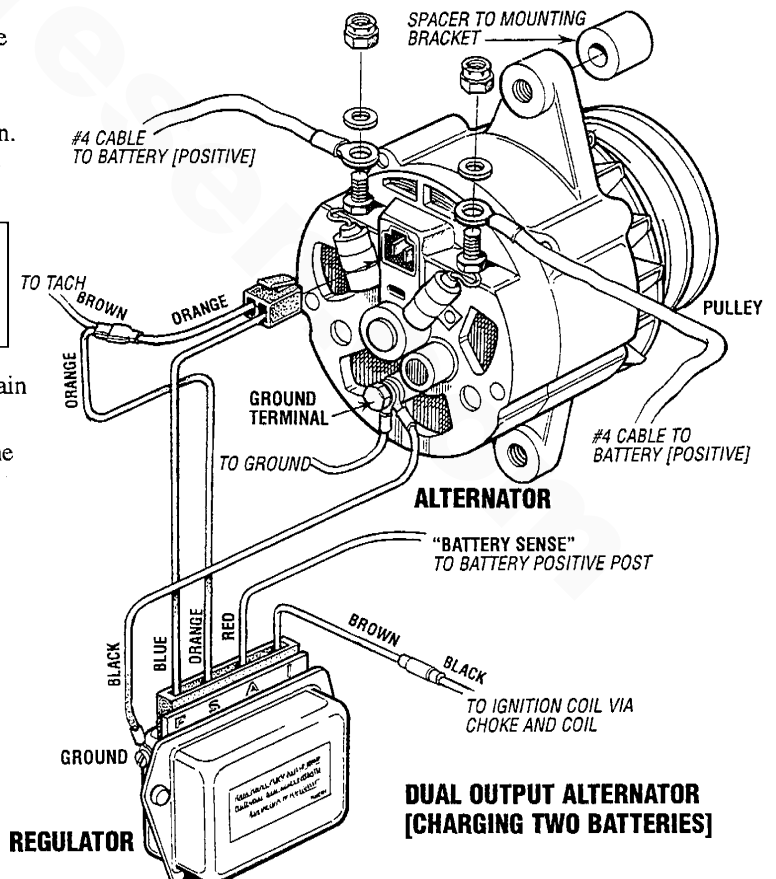
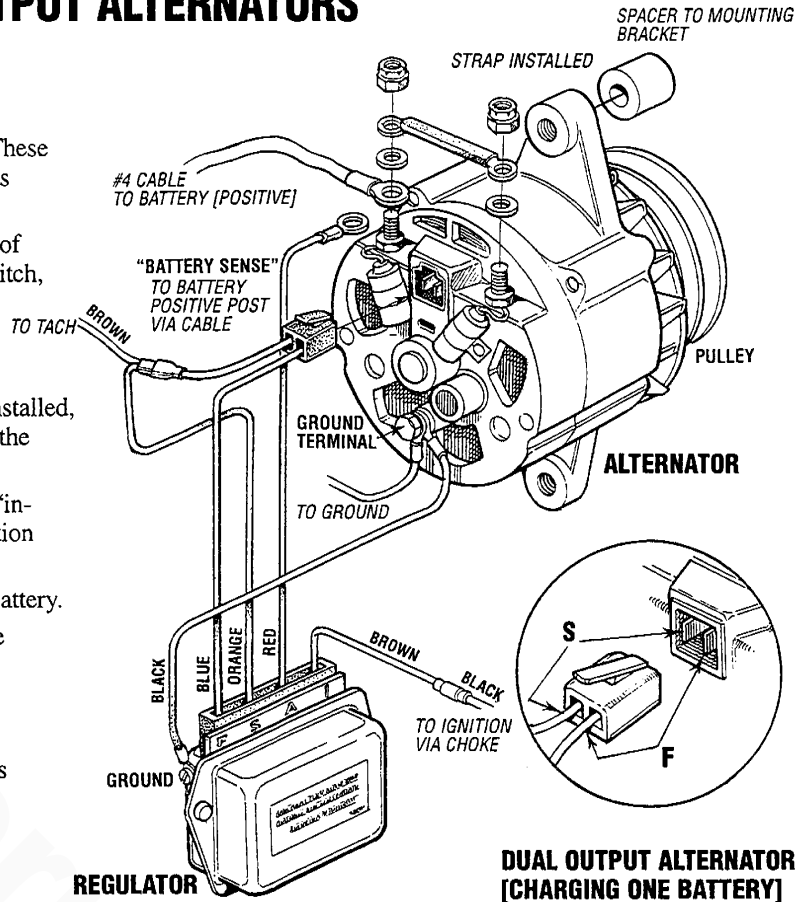

DUAL OUTPUT ALTERNATORS

TROUBLESHOOTING

NOTE: Before troubleshooting, make certain that the drive belts are tight and the batteries are in good condition.

Regulator Testing

The red "battery sensing" wire **A** connects to the battery, it must always read battery voltage. If battery voltage is not present, trace the wire for a bad connection.

The orange wire **S** should read 0 volts with the key off, 12 volts [approximately] with the key on. If the readings are incorrect, trace the wire for a bad connection.

The blue wire **F** supplies current to the alternator fields, its voltage will vary depending on the battery charge or actual load/rpm. The readings can vary from 4 to 12 volts with the key on, 0 volts with the key off.

KEY ON - NO VOLTAGE REGULATOR IS DEFECTIVE
KEY OFF - BATTERY VOLTAGE REGULATOR IS DEFECTIVE

REGULATOR TEST POINTS AND PROPER VOLTAGE

Terminal/Color	Ignition Off	Ignition On	Engine Running
I Brown	0 volts	2 -12 volts	14.2 volts
A Red	12.6 volts	12 volts	14.2 volts
S Orange	0 volts	0 volts	6 - 8 volts
F Blue	0 volts	10 - 11 volts	4 - 12 volts
Alt. Output	12.6 volts	12 volts	14.2 volts

Alternator Testing

The regulator is functioning properly and the batteries are in good condition.

1. Test the voltage at the alternator plug with the engine off-key on. The voltage at the alternator terminal **F** and the voltage in the plug [blue wire **F**] from the regulator should read the same.
2. Hold a screw driver close [1/2"] to the alternator pulley. If voltage is present you should feel the magnetic field. If not, the problem may be the brushes [worn] or the rotor [open circuit].
3. Start the engine, at fast idle the output terminals should indicate 14.2 volts [no load]. A reading of 12.6 would indicate the alternator is not performing properly.

Apply a load such as an electric bilge pump, the voltage should maintain at least 13.8 volts. 13 volts or less indicates the alternator is faulty.

NOTES:

- When the engine is first started, it takes a few moments for the alternator to "kick in" and take the load [a noticeable change in the sound of the engine].
- A slight whine from the alternator when the load is normal.
- When the alternator is producing high amperage, it will become very hot.
- When replacing the alternator drive belts, always purchase and replace dual belts in matched pairs.



90A FOUR PROPULSION ENGINE

WIRING DIAGRAM #41343

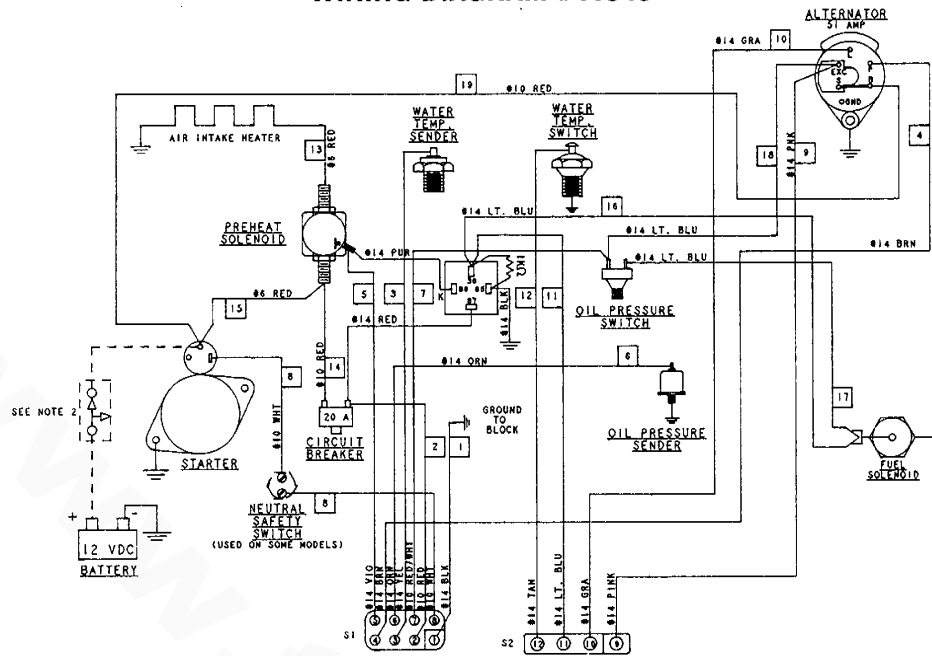

NOTE:

AN ON-OFF SWITCH SHOULD BE INSTALLED BETWEEN THE BATTERY AND STARTER TO DISCONNECT THE BATTERY IN AN EMERGENCY AND WHEN LEAVING THE BOAT. A SWITCH WITH A CONTINUOUS RATING OF 300 AMPS AT 12 VDC WILL SERVE THIS FUNCTION. THIS SWITCH SHOULD NOT BE USED TO MAKE OR BREAK THE CIRCUIT.

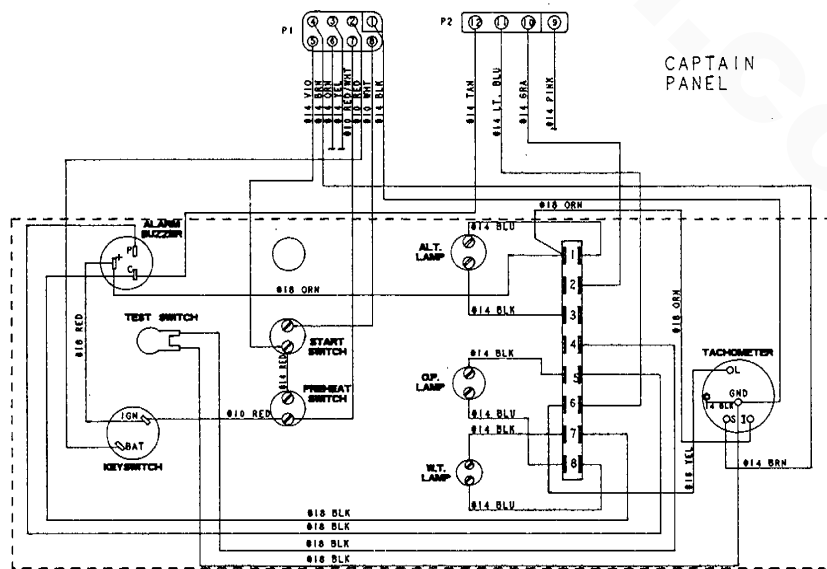
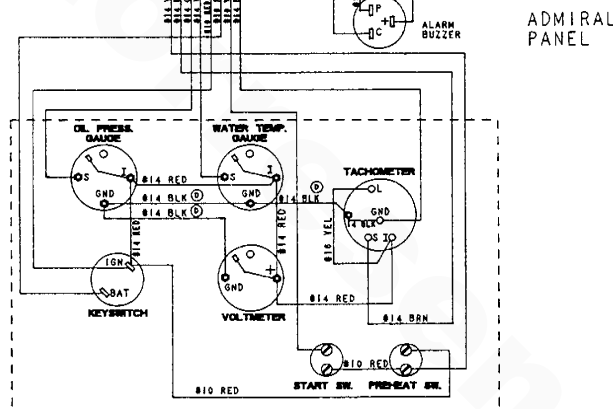

90A FOUR PROPULSION ENGINE

WIRING SCHEMATIC #41343

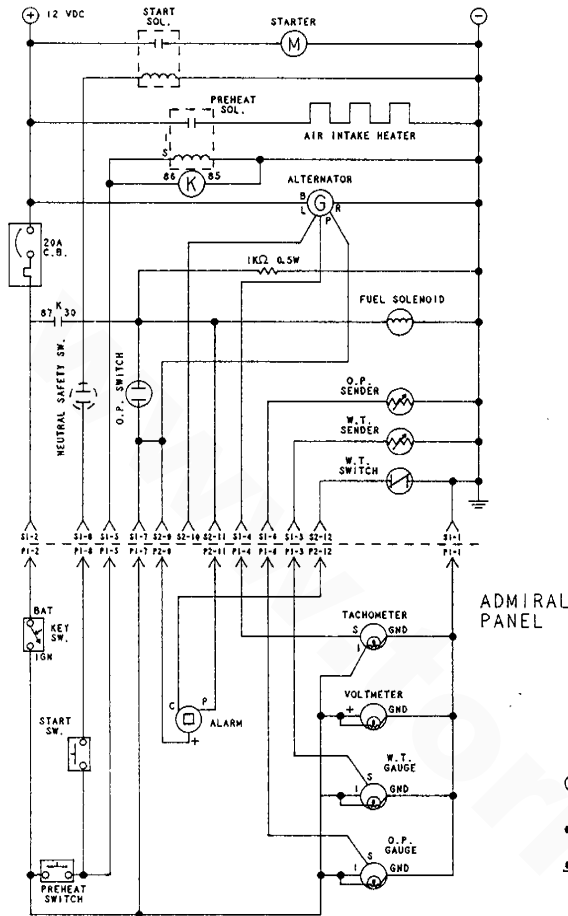

ADMIRAL PANEL

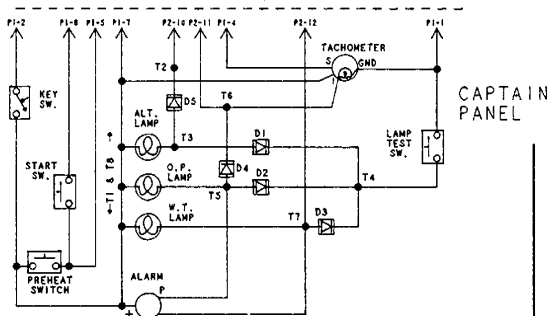

CAPTAIN PANEL

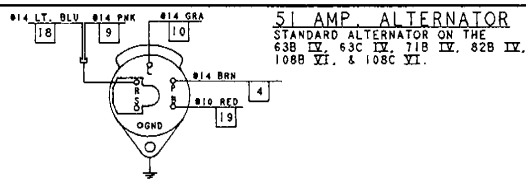

51 AMP ALTERNATOR
STANDARD ALTERNATOR ON THE
63B IV, 63C IV, 71B IV, 82B IV,
108B VI, & 108C VI.

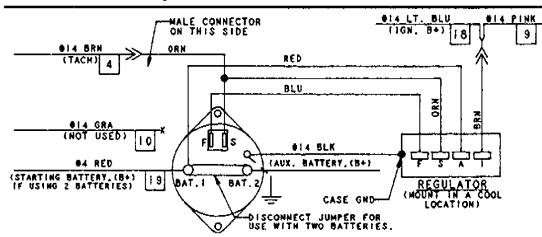

OPTIONAL ALTERNATORS

AVAILABLE ON THE 63B IV, 63C IV, 71B IV, 82B IV, 108B VI, & 108C VI ONLY.

NOTES:

1. This product is protected by a manual reset circuit breaker located near the starter. Excessive current will cause the breaker to trip and the engine will shut down. The builder/owner must be sure that the instrument panel, wiring and engine are installed to prevent contact between electrical devices and seawater.
2. An On-Off switch should be installed between the battery and the starter to disconnect the battery in an emergency and when leaving the boat. A switch with a continuous rating of 300 amps at 12 VDC will serve this function. This switch should not be used to make or break the circuit.
3. The pink wire at plug 2 is unused and should be insulated, Captain Panel only.
4. The gray wire at plug 2 is unused and should be insulated, Admiral Panel only.

LEECE NEVILLE 90 AMP. ALT.

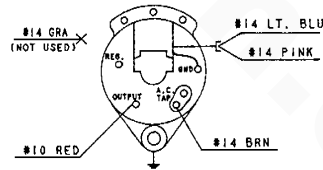
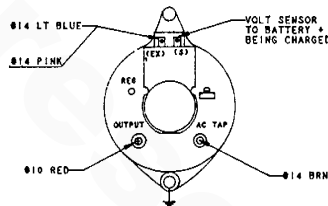

PRESTOLITE 72 AMP. ALT.



HURTH HSW TRANSMISSIONS

SHIPMENT

For safety reasons, the transmission is *not* filled with transmission fluid during shipment and the selector lever is temporarily attached to the actuating shaft.

Before leaving the WESTERBEKE plant, each transmission undergoes a test run, with *Dextron III ATF* transmission fluid. The residual fluid remaining in the transmission after draining acts as a preservative and provides protection against corrosion for at least one year if properly stored.

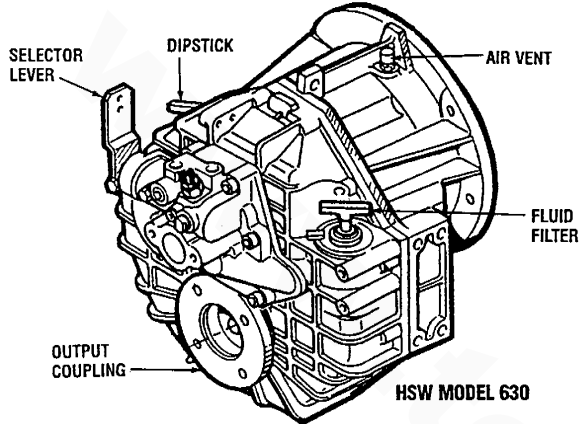

OIL COOLER

The oil cooler, mounted above the transmission, provides continuous cooling for the transmission fluid. Raw water passes through the tubes of the cooler and discharges overboard. The transmission fluid is cooled as it flows around the tubes and back into the transmission.

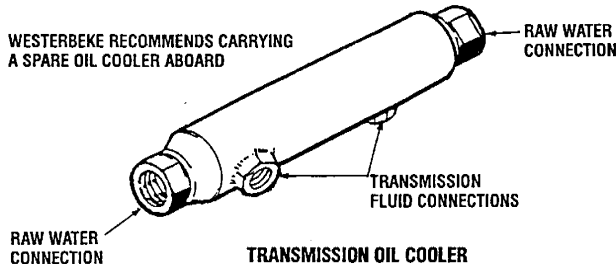

TRANSMISSION FLUID

Fill the transmission with *Dextron III ATF*. The fluid level should be up to the mark on the dipstick. After checking the level, press the dipstick into the case and turn it to tighten. During the first 25 operating hours, inspect the bell housing, output shaft and transmission cooler for leakage. The fluid should be changed after the first 25 hours and every 300 hours thereafter.

NEUTRAL SWITCH

These transmissions are equipped with a neutral safety switch. This is to prevent the engine from starting in gear. Unless the transmission selector lever is perfectly aligned in neutral, the engine starter will not activate.

INITIAL OPERATION

Set the shifting lever to neutral position (N). Start the engine and let it run long enough in idle to fill the cooler and hoses with transmission fluid. Shift into gear, forward and reverse; shifting should be smooth and positive. Direct changes from forward to reverse are permissible since the multiple disc clutch permits changing at high rpm including sudden reversing at high speeds in the event of danger.

After initial operation, make a visual inspection of the output coupling, oil cooler and hoses, and the cable connections to the transmission.

LOCKING THE PROPELLER

Locking of the propeller shaft by an additional brake is not required: use the gear shift lever position opposite your direction of travel for this purpose. Never put the gear shift in the position corresponding to the direction of travel of the boat.

WHEN UNDER SAIL OR BEING TOWED

Rotation of the propeller without a load, such as when the boat is being sailed, being towed or anchored in a river, as well as operation of the engine with the propeller stopped (for charging the battery), will have no detrimental effects on the transmission.

NOTE: *When the boat is being sailed (engine stopped), the gear shift must be in the neutral position. The propeller is at idle and can free-wheel.*

DAILY OPERATION

- Check the transmission fluid.
- Visually check the gear shift linkage and transmission.
- Start the engine in neutral, allowing a few minutes at idle to warm the fluid.
- Shift into gear.

NOTE: *Too low an idle speed will produce a chattering noise from the transmission gear and damper plate. In such cases the idle speed should be increased.*

Operating Temperature

The operating temperature of the transmission should not exceed 176°F (80°C). A connection for a temperature probe is provided. At maximum output of the engine, the fluid may reach 220°F (104°C).

CAUTION: *If the transmission fluid temperature is too high, stop the engine immediately and check the transmission fluid.*



HURTH HSW TRANSMISSIONS

CHANGING THE TRANSMISSION FLUID

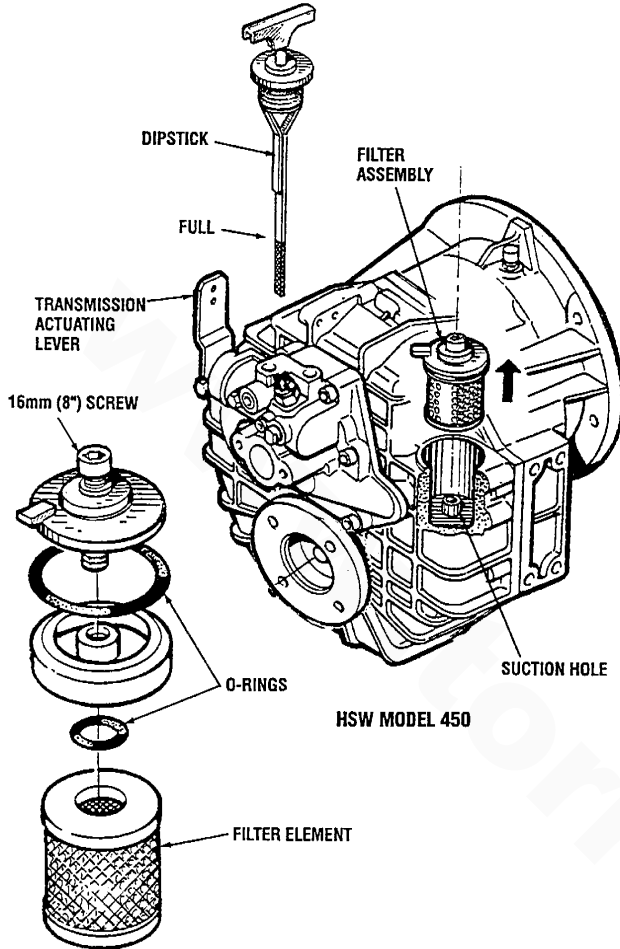

Filter Element

The Hurth HSW transmission has a filter element located opposite the dipstick. This filter must be replaced whenever the fluid is changed.

Remove the filter by loosening the screw on the cover using a 6mm Allen wrench.

Twist and pull out the filter and remove the element. Place the new filter onto the cover and lock it into place by turning it clockwise. Check the O-rings for damage and replace if necessary. Replacement filters can be obtained from your local WESTERBEKE dealer or ZF (Hurth dealer).

Removing the Fluid

Push a suction pump hose down through the pipe hole (under the filter) to the bottom of the housing and suck out the fluid.

Remove the oil return line from the cooler and allow the oil to drain into a container, then reconnect the oil return line.

Wipe down the transmission and properly dispose of the used fluid.

Replacement Filter:

Hurth Part No. 500012

Replacing the Fluid

Pour in new *Dextron III ATF* fluid and check the quantity with the dipstick.

Transmission fluid quantities will vary with the use of coolers, length of hoses and the angle of the transmission.

Approximate Quantities

HSW450 — 2.12 quarts (2.0 Liters)

HSW630 — 3.2 quarts (3.0 Liters)

HSW630V — 4.2 quarts (4.0 Liters)

Reinsert the filter assembly into the housing. Press it in place and tighten the Allen screw.

NOTE: Some HSW transmissions use a "T" handle in place of a screw on their filter assemblies.

After running the engine, shut down and recheck the fluid level.

⚠ WARNING: Never pull out the dipstick while the engine is running. Hot fluid will splash from the dipstick hole. This could cause severe burns.

MAINTENANCE

Transmission maintenance is minimal. Keep the exterior housing clean, check the fluid level as part of your regular routine, and change the fluid every 300 operating hours.

Periodically inspect the transmission and the cooler for leaks and corrosion. Make certain the air vent is clear and when checking the fluid level look for signs of water contamination (fluid will appear as strawberry cream).

Lay-up/Winterize

Storage requires special care. Follow these procedures:

Drain water from the transmission oil cooler and replace with a proper mixture of antifreeze coolant.

NOTE: This operation will normally occur when the engine raw water cooling system is properly winterized.

Clean up the transmission and touch up unpainted areas (use heat resistant paint).

Fill the transmission with *Dextron III ATF* fluid to the full mark on the dipstick.

Loosen attaching hardware from the transmission output flange and propeller shaft coupling flange before removing the boat from the water. Separate the flanges and spray with lubricant.

Inspect the gear shift cable, linkage, and attachments. Look for corrosion of the end fittings, cracks or cuts in the conduit, and bending of the actuator rods. Lubricate all moving parts.

NOTE: If the transmission is to be stored for a long time (twelve months or more), it should be topped off with fluid to prevent internal corrosion. Reduce the fluid level before putting the engine back into service.



HURTH HSW TRANSMISSIONS

CABLE CONNECTIONS

The transmission is suitable for a single lever gear shift. Upon loosening the retaining screw, the actuating lever (see illustration) can be moved to any position required for the control elements (cable or rod linkage). Make certain that the actuating lever does not contact the lever hub: the minimum distance between the lever and hub should be 0.02in(0.5mm).

The control cable or rod should be arranged at a right angle to the actuating lever when in the neutral position. The neutral position of the gear shift lever on the control console should coincide with the neutral position of the lever on the transmission.

Shifting Positions:

A= Propeller rotation opposite of engine rotation.

N= Neutral position

B= Propeller rotation same as engine rotation.

NOTE: When shifting to "A" or "B" positions, make sure the shift lever travel is sufficient for the lever to contact its stop.

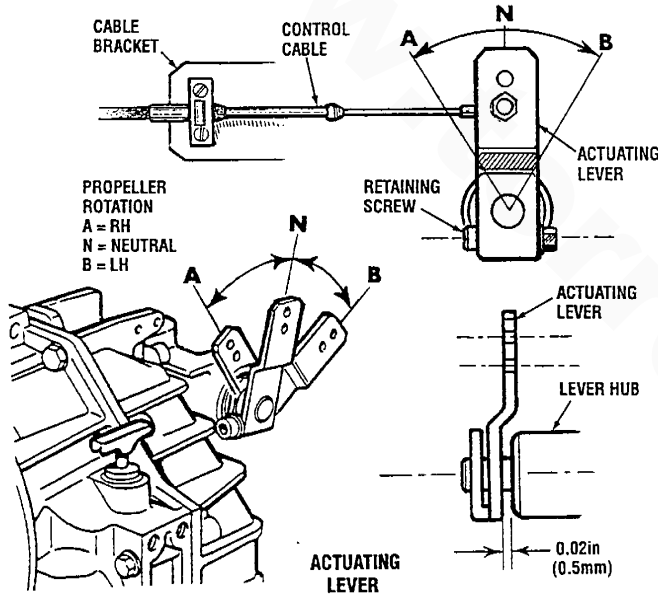

A greater amount of actuating lever travel is in no way detrimental and is recommended. However, if the lever travel is shorter, proper clutch engagement might be impeded which, in turn, would mean premature wear, excessive heat generation and clutch plate failure. This would be indicated by slow clutch engagement or no engagement at all (see **CONTROL CABLES** under **TRANSMISSION TROUBLESHOOTING**)

NOTE: Check for proper actuating lever travel at least each season.

CAUTION: The position of the mechanism behind the actuating lever is factory-adjusted to ensure equal actuating lever travel from Neutral position N to Reverse position A and Forward position B. If this mechanism is in any way tampered with, the transmission warranty will be void.

SHAFT COUPLINGS

WESTERBEKE recommends a flexible connection between the transmission and the propeller shaft if the engine is flexibly mounted, in order to compensate for angular deflections. The installation of a special propeller thrust bearing is not required, since the propeller thrust will be absorbed by the transmission bearing, provided the value specified under **SPECIFICATIONS** is not exceeded. However, the output shaft should be protected from additional loads. Special care should be taken to prevent torsional vibration. When using a universal joint shaft, make certain to observe the manufacturer's instructions.

Even with the engine solidly mounted, the use of a flexible coupling or "DRIVESAVER" will reduce stress in the gearbox bearings caused by hull distortions, especially in wooden boats or where the distance between the transmission output coupling and stern gland is less than about 800mm.

NOTE: When installing the transmission, make certain that shifting is not impeded by restricted movability of the cable or rod linkage, by unsuitably positioned guide sheaves, too small a bending radius or other restrictions. In order to mount a support for shift control cable connections, use the two threaded holes located on the cable bracket mounted on the gear housing. Refer to the WESTERBEKE parts list.

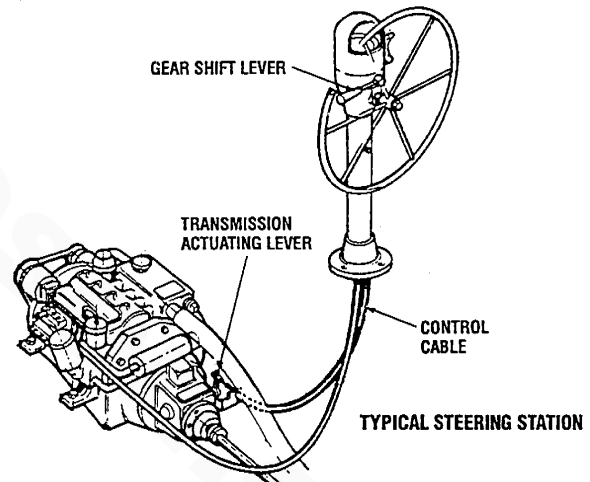

For additional information contact:

HURTH MARINE GEAR
ZF Industries
Marine US Headquarters
3131 SW 42nd Street
Fort Lauderdale, FL 33312
Tel.: (954) 581-4040
Fax: (954) 581-4077



HURTH HBW 250 TRANSMISSION

DESCRIPTION

The 90A Four engine is also being equipped with the HBW 250 transmission. The information below is specific to the HBW 250, the **TRANSMISSION TROUBLESHOOTING SECTION** applies to all models.

CONNECTION OF GEAR BOX WITH PROPELLER

HBW recommend a flexible connection between the gearbox and the propeller shaft if the engine is flexibly mounted, in order to compensate for angular deflections. The installation of a special propeller thrust bearing is not required, since the propeller thrust will be taken by the transmission bearing, provided the value specified under **SPECIFICATIONS** is not exceeded. However, the output shaft should be protected from additional loads. Special care should be taken to prevent torsional vibration. When using a universal joint shaft, make certain to observe the manufacturer's instructions.

Even with the engine solidly mounted, the use of flexible coupling reduces stresses in gearbox bearings caused by hull distortions, especially in wooden boats or where the distance between gearbox output flange and stern gland is less than about 800mm.

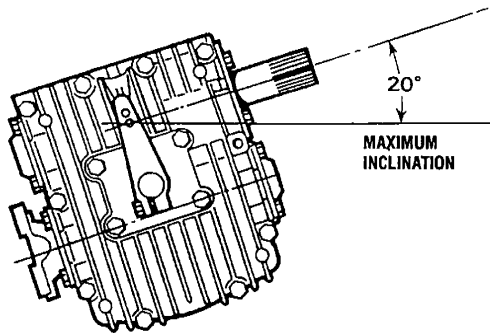
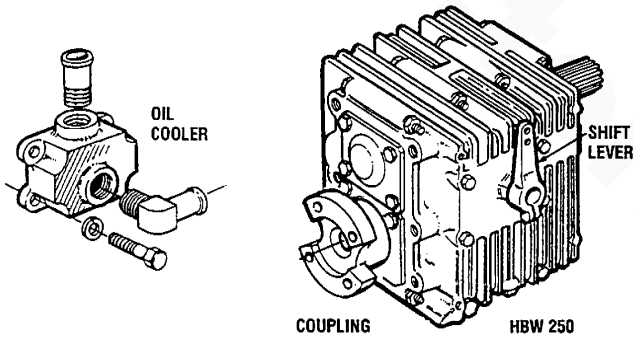

NOTE: When installing the gearbox, make certain that shifting is not impeded by restricted movability of the Bowden cable or rod linkage, by unsuitably positioned guide sheaves, too small a bending radius, etc. In order to mount a support for shift control cable connections, use the two threaded holes located above the shift cover on top of the gear housing. Refer to the **WESTERBEKE** parts list.

CONTROL CABLES

The gearbox is suitable for single lever remote control. Upon loosening the retaining screw, the actuating lever can be moved to any position required for the control elements (cable or rod linkage). Make certain that the shift lever does not contact the actuating lever cover plate: the minimum distance between lever and cover should be 0.5mm.

The control cable or rod should be arranged at right angle to the actuating shift lever when in the neutral position. The neutral position of the operating lever on the control console should coincide with the neutral position of this lever.

The shifting travel, as measured at the pivot point of the actuating lever, between the neutral position and end positions **A** and **B** should be at least **35mm** for the outer and **30mm** for the inner pivot point.

A greater amount of shift lever travel is in no way detrimental and is recommended. However, if the lever travel is shorter, proper clutch engagement might be impeded which, in turn, would mean premature wear, excessive heat generation and clutch plate failure. This would be indicated by slow clutch engagement or no engagement at all.

NOTE Check for proper lever travel at least each season.

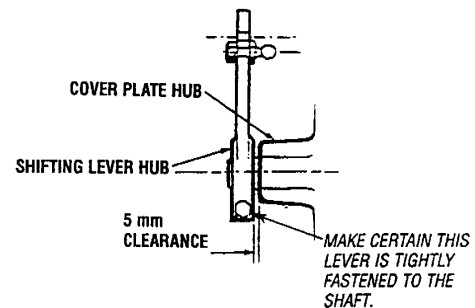
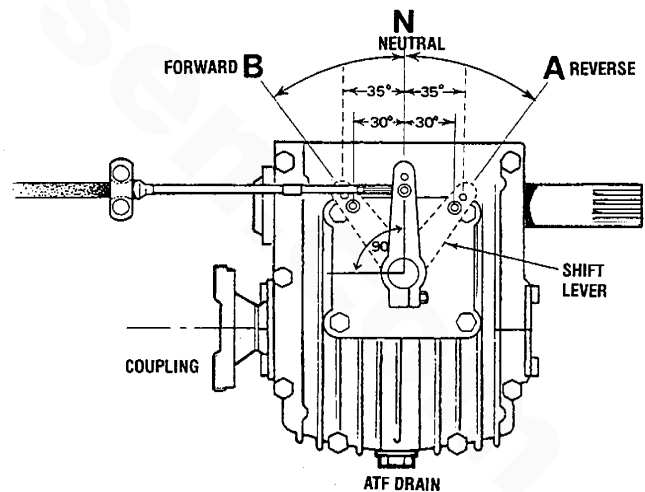

CAUTION: The position of the mechanism behind the actuating lever is factory-adjusted to ensure equal actuating lever travel from Neutral position N to Reverse position A and Forward position B. If this mechanism is in any way tampered with, the transmission warranty will be void.



HURTH HBW 250 TRANSMISSION

INITIAL OPERATION

All HBW marine transmissions are test-run on a test stand with the engine at the factory prior to delivery. For safety reasons the fluid is drained before shipment.

Fill the gearbox with Automatic Transmission Fluid (DEXRON II or DEXTRON III). The fluid level should be up to the index mark on the dipstick. To check the fluid level, just insert the dipstick, do not screw it in. Screw the dipstick into the case after the fluid level is checked and tighten. Do not forget the sealing ring under the hexhead of the dipstick. Check for leaks and change the fluid after the first 25 hours, also make a visual inspection of the coupling, oil cooler and hoses, and shift cables.

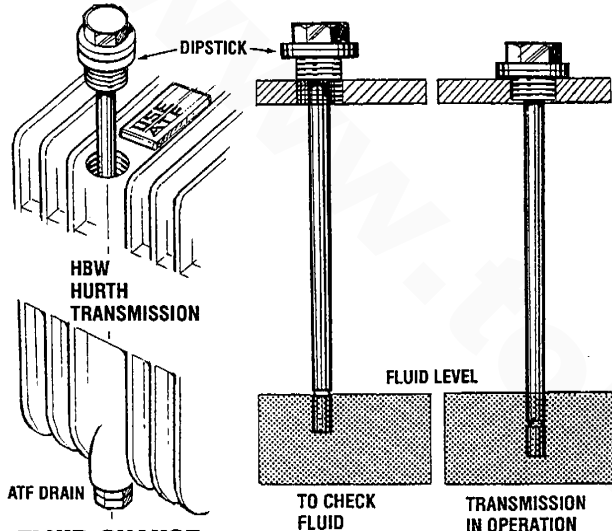

FLUID CHANGE

Change the fluid for the first time after about 25 hours of operation, then every 250 operating hours or at least once a year or when you change engine oil.

Removing the fluid

Push a suction pump hose down through the dipstick hole to the bottom of the housing and suck out the fluid. (If space allows, use the transmission drain). Remove the drain plug from the bottom of the transmission and allow the fluid to drain into a container, then reinstall the plug with its sealing washer. Wipe down the transmission and properly dispose of the used fluid. After running the engine, shut down and recheck the fluid level.

Drain plug torque: 20 - 25 ft/lbs

NOTE: When changing the fluid, take care not to lose the drain plug sealing washer. The drain plug will leak without this sealing washer.

WARNING: Never pull out the dipstick while the engine is running. Hot fluid will splash from the dipstick hole. This could cause severe burns.

OPERATING TEMPERATURE

The maximum permissible ATF temperature should not exceed 230°F (110°C). This temperature can only be reached for a short time.

CAUTION: If the transmission fluid temperature is too high, stop the engine immediately and check the transmission fluid.

LOCKING THE PROPELLER

Locking of the propeller shaft by an additional brake is not required: use the gear shift lever position opposite your direction of travel for this purpose. Never put the gear shift in the position corresponding to the direction of travel of the boat.

WHEN UNDER SAIL OR BEING TOWED

Rotation of the propeller without load, such as when the boat is being sailed, being towed, or anchored in a river, as well as operation of the engine with the transmission in neutral (for charging the battery), will have no detrimental effects on the transmission.

DAILY OPERATION

- Check the transmission fluid.
- Visually check the gear shift linkage and transmission.
- Start the engine in neutral, allowing a few minutes at idle to warm the fluid.
- Shift into gear.

NOTE: Too low an idle speed will produce a chattering noise from the transmission gear and damper plate. In such cases the idle speed should be increased.

For additional information refer to the following text in this Transmission Section: *SHAFT COUPLINGS, MAINTENANCE AND TRANSMISSION TROUBLESHOOTING.*

HBW 250 TRANSMISSION SPECIFICATIONS

General	(Hurth Standard Transmission) Case-hardened helical gears, with a servo-operated multiple disc clutch.
Gear ratio (standard)	2.74 : 1 (HBW250 - 3R)
Propeller Shaft Direction of Rotation	Right handed - standard transmission
Propeller Recommendations (using standard transmission 2.74:1 reduction)	24 D x 12 P-2 blade or 22 D x 14 P-3 blade propeller should allow the engine to reach its full rated rpm (3600 + 000 - 100) at full open throttle while under way in forward gear.
Lubricating Fluid	ATF - type A or Dextron - II or III
Transmission Sump Capacity	0.79 U.S. qts (0.75 liters) approximate



BORG WARNER VELVET DRIVE TRANSMISSION

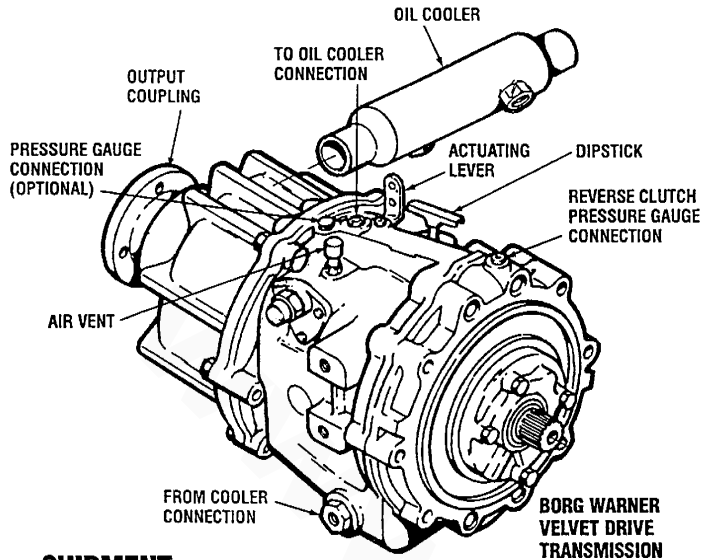

SHIPMENT

For safety reasons, the transmission is *not* filled with transmission fluid during shipment and the selector lever is temporarily attached to the actuating shaft.

Before leaving the WESTERBEKE plant, each transmission undergoes a test run, with *Dextron III ATF* transmission fluid. The residual fluid remaining in the transmission after draining acts as a preservative and provides protection against corrosion for at least one year if properly stored.

TRANSMISSION FLUID

Check the transmission fluid level on the dipstick. If the transmission has not been filled, fill with *Dextron III* and continue to use this fluid. During the first 25 hours of operation, keep a lookout for any leakage at the bell housing, output shaft and transmission cooler. This fluid should be changed after the first 25 hours and approximately every 300 operating hours thereafter and/or at winter lay-up.

CAUTION: Be certain the transmission is filled and the correct size cooler is properly installed before starting the engine.

SHIFT LEVER POSITION

The gear shift control mechanism and linkage must position the actuating lever on the transmission exactly in Forward (F), Neutral (N), and Reverse (R) shifting positions. A detent ball located behind the transmission lever must work freely to center the lever in each position. The gear shift positions at the helm must be coordinated with those of the Velvet Drive actuating lever through shift mechanism adjustments. An improperly adjusted shift mechanism can cause damage to the transmission. The shifting mechanism and transmission actuating lever should be free of dirt and well lubricated to ensure proper operation.

Shifting Into Gear

Place the gear shift in Neutral before starting the engine. Shifting from one selector position to another selector position may be made at any time below 1000 rpm and in any order. Shifts should be made at the lowest *practical* engine speed. Start the engine and set the throttle at idle speed; allow the transmission fluid to warm up for a few minutes.

Neutral

Move the gear shift lever to the middle position. You should feel the detent. This centers the actuating lever on the transmission. With the control in this position, hydraulic power is completely interrupted and the output shaft of the transmission does not turn.

NOTE: Some transmissions are equipped with a neutral safety switch. Unless the transmission actuating lever is perfectly aligned in neutral, the engine starter will not activate.

Forward

Move the gear shift lever to the forward position. You should feel the detent. The actuating lever on the transmission is in the forward position. The output shaft and the propeller shaft move the boat in a forward direction.

Reverse

Move the gear shift lever to the reverse position. You should feel the detent. The actuating lever on the transmission is in the reverse position. The output shaft and the propeller should move the boat in a reverse direction (astern).

NOTE: Moving the transmission actuating lever from Neutral Position to Forward is always toward the engine. Reverse is always away from the engine. If boat moves backwards with the gear shift control in the forward position, shut off the engine! This problem may be a result of incorrect movement of the actuating lever by the gear shift lever.



BORG WARNER VELVET DRIVE TRANSMISSION

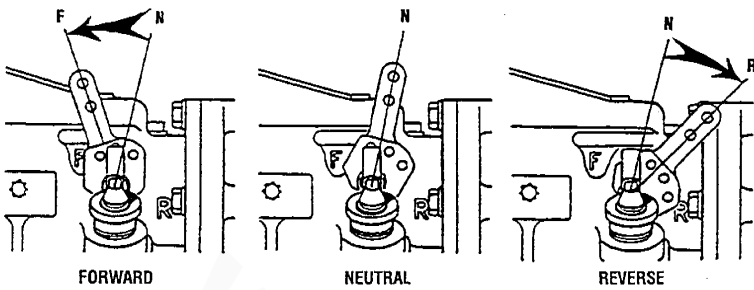

FORWARD NEUTRAL REVERSE
TRANSMISSION ACTUATING LEVER POSITIONS

DAILY OPERATION

- Check the transmission fluid.
- Visually check the gear shift linkage and transmission.
- Start the engine in neutral. Allow a few minutes at idle for the fluid to warm.

NOTE: Too low an idle speed will produce a chattering noise from the transmission gear and damper plate. In such cases the idle speed should be increased.

- Shift into gear.

CAUTION: Shifting gears above 1000 rpm can cause damage to the engine damper plate. Pulling the throttle back to idle when shifting gears will save wear on the transmission and the damper plate.

INSPECTION

- Visually check for oil leaks at the hydraulic connections. Check for wear on the hydraulic lines and replace if worn.
- Lubricate the detent ball and shift cable attachments.
- Inspect the shift linkage.
- Inspect the transmission bolts; retorque if necessary.

CAUTION: Clutch failure will occur if the transmission shift lever does not fully engage the detent ball positions.

CHANGING THE TRANSMISSION FLUID

After the initial 50 hour change, the transmission fluid should be changed at every 300 operating hours thereafter or at winter haul-out. However, the fluid must be changed whenever it becomes contaminated, changes color, or smells rancid.

- Remove the oil filler cap and dipstick.
- Remove the oil cooler return line and allow the oil to drain into a container.
- Reconnect the oil cooler return line.
- Use a suction pump to remove the transmission oil through the filler cap/dipstick hole.

- Clean off the transmission and properly dispose of the used fluid.
- Refill the transmission with *DEXTRON III ATF*. The quantity will vary depending on the transmission model and the installation angle. Fill through the dipstick hole.
- Check the dipstick for the proper fluid level.
- Replace the oil filler cap and dipstick. (Press the dipstick into place and turn clockwise until finger-tight.)
- Run the engine, shutdown and recheck the fluid level.

WARNING: Never pull out the dipstick while the engine is running. Hot fluid will splash from the dipstick hole. This could cause severe burns.

Oil Capacity

Approximately 2.5 quarts (2.36 liters) will fill most transmissions to the oil level fill mark on the dipstick. Many variables have a direct relationship to the oil capacity. Additional oil will be required to fill the oil cooler and the cooler lines. The angle of installation will make a difference in the quantity of oil required to fill the transmission.

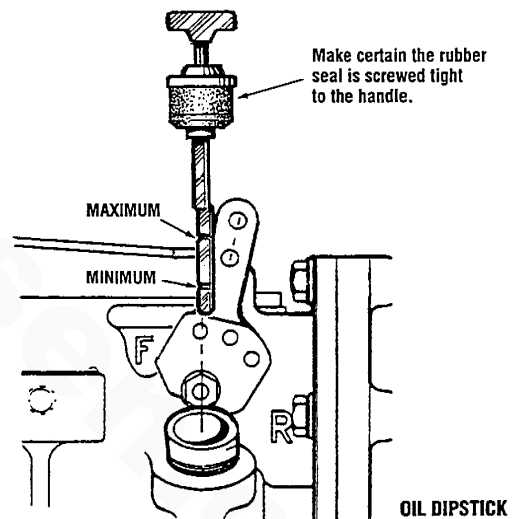

Oil Temperature

A maximum oil temperature of 190°F (88°C) is recommended. Discontinue operation anytime sump oil temperature exceeds 230°F (110°C).

PRESSURE GAUGE

An optional mechanical pressure gauge can be installed at the control panel to constantly monitor the pressure of the transmission fluid. A normal reading at 2000 rpm in forward gear should indicate 95 – 120 lb-in² (6.7 – 8.4 kg-cm²) and be constant.

BORG WARNER VELVET DRIVE TRANSMISSION

MAINTENANCE

Transmission maintenance is minimal. Keep the exterior housing clean, check the fluid level as part of your regular routine, and change the fluid every 300 operating hours.

Periodically inspect the transmission and the cooler for leaks and corrosion. Make certain the air vent is clear and when checking the fluid level look for signs of water contamination (fluid will appear as strawberry cream).

Lay-up/Winterize

Storage requires special care. Follow these procedures:

- Drain the water from the transmission oil cooler and replace it with a proper mixture of antifreeze coolant.

NOTE: *This operation will usually occur when the engine raw water cooling system is properly winterized.*

- Clean up the transmission and touch-up unpainted areas (use heat resistant paint).
- Fill the transmission with *Dextron III ATF* fluid to the full mark on the dipstick.
- Loosen attaching hardware from the transmission output flange and propeller shaft coupling flange before removing the boat from the water. Separate the flanges and spray with lubricant.
- Inspect the gear shift cable, linkage, and attachments. Look for corrosion of the end fittings, cracks or cuts in the conduit, and bending of the actuator rods. Lubricate all moving parts.

NOTE: *If the transmission is to be stored for a long time (twelve months or more), it should be topped off with fluid to prevent internal corrosion. Reduce the fluid level before putting the engine back into service.*

WARRANTY NOTES

Service manuals are available from your *BORG WARNER* dealer.

For assistance, contact:

BORG WARNER
200 Theodory Rice Blvd.
New Bedford, MA 02745
Tel.: (508) 979-4881

BORG WARNER is aware of the shock loads that can be placed on its gears as the result of mechanical propeller operation or fully reversing of the propeller blades while shifting. Therefore torque loads and directional changes should be made at low engine speeds. If it is found that a failure was caused by a shock load, any warranty claim will be denied.

⚠ CAUTION: *System-related noises or vibrations can occur at low engine speeds which can cause gear rattle resulting in damage to the engine and/or transmission. BORG WARNER is not responsible for total system-related torsional vibration of this type.*

If any problems occur with the transmission, see *TRANSMISSION TROUBLESHOOTING* in this manual.

TRANSMISSION TROUBLESHOOTING

CONTROL CABLES

The majority of transmission difficulties arise as a result of improper clutch adjustments (manual transmissions) or problems with control cables (hydraulic transmissions) rather than from problems with the transmission itself.

HURTH clutches, in particular, are very sensitive to improper cable adjustments.

If you experience operating problems with the transmission, shut the engine down. First check the transmission-oil level, then have a helper move the cockpit shift lever through the full range — from neutral to full forward, back to neutral, into full reverse, and back to neutral — while you observe the actuating lever on the transmission. If the remote is stiff to operate, break the cable loose at the transmission and try again. If it is still stiff, check the cable for kinks or excessively tight bends, and check any linkage for binding. A new cable and perhaps a new linkage mechanism may be needed. While the cable is loose, shift the transmission in and out of gear using the lever on the side of the transmission to make sure there's no binding inside the case.

If the transmission passes these tests, crank the engine and have a helper put it in forward and reverse while you observe the propeller shaft; if the shaft isn't turning, the transmission needs professional attention. If it does turn but there's no thrust, check to see you still have a propeller on the end of the shaft or, if you have a folding or feathering propeller, that it isn't stuck in the "no pitch" position.

OIL COOLERS

The continued flow of raw water through the cooler will, in time, erode the inside of the cooler causing cross leaks to occur. These internal cooler leaks will cause one of the following two problems:

1. Transmission fluid will leak into the flow of raw water and be discharged overboard through the engine exhaust. *A loss of transmission fluid will cause the transmission to fail.*
2. The raw water will leak into the transmission fluid causing an increase in transmission fluid. This contaminated fluid will appear as strawberry cream. *The transmission will eventually fail.*

Either case requires an immediate response:

1. Install a new oil cooler.
2. Refill the transmission with *DEXTRON III ATF*.

If water has contaminated the fluid, the transmission fluid needs to be cleaned out and replaced with fresh fluid. It will take several fluid changes to get rid of the contamination. Check your dipstick each time until it appears as pure transmission fluid. Change the transmission filter and clean out the fluid lines that connect to the cooler.

If the transmission fails to shift properly, it will most likely need the attention of a qualified transmission service facility.

A transmission cooler may last ten years or more but, in some circumstances, depending on operating hours, tropical waters, maintenance, etc. it might only last half that time.

WESTERBEKE recommends having a spare cooler aboard.

Problem	Probable Cause	Verification/Remedy
Transmission gears cannot be shifted.	<ol style="list-style-type: none"> 1. Shifting lever is loose. 2. Shifting cable is broken, bent or unattached. 3. Loss of transmission fluid. 4. Water in transmission fluid. 	<ol style="list-style-type: none"> 1. Tighten damping bolt on shifting lever. 2. Check the cable, reattach or replace. 3. Check for leaks at transmission seal and output shaft. Tighten gear case bolts. Check all oil hoses for leaks. Oil cooler leak — see <i>OIL COOLER</i>. 4. Replace oil cooler (see <i>OIL COOLER</i>). High water in engine compartment, remedy cause. Shifting pressure too low, see item 2.
Shifting pressure too low.	<ol style="list-style-type: none"> 1. Improper fluid. 2. Filter is dirty (if applicable). 3. Water in transmission fluid. 4. Transmission fluid too low. 5. Air vent is clogged. 	<ol style="list-style-type: none"> 1. Replace with <i>DEXTRON III ATF</i>. 2. Replace filter. 3. Replace oil cooler — see <i>OIL COOLER</i>. 4. Add fluid. 5. Remove paint/dirt from vent.
Transmission noise becomes louder.	<ol style="list-style-type: none"> 1. Fluid level too low, so that pump sucks in air. 2. Damage starting on flexible coupling due to wear or fatigue, possibly due to misalignment between engine and transmission. 3. Beginning damage of bearings in transmission due to torsional vibrations, running without fluid, overload, wrong alignment of transmission, or excessive engine output. 	<ol style="list-style-type: none"> 1. Top up with fluid to marking on dipstick. 2. Replace flexible coupling. Check alignment between engine and transmission. 3. Transmission needs professional attention.

(continued)



TRANSMISSION TROUBLESHOOTING

Problem	Probable Cause	Verification/Remedy
Chattering transmission noise, mainly at low engine speed.	<ol style="list-style-type: none"> 1. The engine or propeller generates torsional vibrations in the drive unit which produces a "chattering" noise in the transmission. 	<ol style="list-style-type: none"> 1. Mount a flexible coupling with another stiffness factor between the engine and transmission; a coupling with a higher stiffness factor might be sufficient.
Transmission shifts into gear, but fails to propel the boat.	<ol style="list-style-type: none"> 1. Output coupling is not turning. 2. Propeller shaft is not turning. Output coupling is turning. 3. Output coupling and propeller shaft are turning. 	<ol style="list-style-type: none"> 1. Transmission needs professional attention. 2. The coupling bolts are sheared or the coupling is slipping on the propeller shaft. Tighten or replace set screws, keys, pins and coupling bolts as necessary. 3. Inspect the propeller; it may be missing or damaged. A folding propeller may be jammed. Variable pitch propeller may be in "no pitch" position.

NOTE: *If you suspect a major problem in your transmission, immediately contact your WESTERBEKE dealer or an authorized marine transmission facility.*



STANDARD HARDWARE

BOLT HEAD MARKINGS

Bolt strength classes are embossed on the head of each bolt.

Customary (inch) bolts are identified by markings two to grade eight (strongest). The marks correspond to two marks less than the actual grade, i.e.; a grade seven bolt will display five embossed marks.

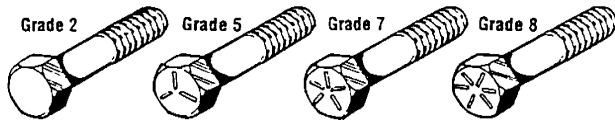

Metric bolt class numbers identify bolts by their strength with 10.9 the strongest.

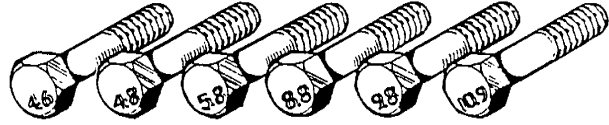

- NOTES:**
1. Use the torque values listed below when specific torque values are not available.
 2. These torques are based on clean, dry threads. Reduce torque by 10% when engine oil is used.
 3. Reduce torques by 30% or more, when threading capscrews into aluminum.

STANDARD BOLT & NUT TORQUE SPECIFICATIONS			
Capscrew Body Size (Inches) - (Thread)	SAE Grade 5 Torque Ft-Lb (Nm)	SAE Grade 6-7 Torque Ft-Lb (Nm)	SAE Grade 8 Torque Ft-Lb (Nm)
1/4 - 20 - 28	8 (11) 10 (14)	10 (14)	12 (16) 14 (19)
5/16 - 18 - 24	17 (23) 19 (26)	19 (26)	24 (33) 27 (37)
3/8 - 16 - 24	31 (42) 35 (47)	34 (46)	44 (60) 49 (66)
7/16 - 14 - 20	49 (66) 55 (75)	55 (75)	70 (95) 78 (106)
1/2 - 13 - 20	75 (102) 85 (115)	85 (115)	105 (142) 120 (163)
9/16 - 12 - 18	110 (149) 120 (163)	120 (163)	155 (210) 170 (231)
5/8 - 11 - 18	150 (203) 170 (231)	167 (226)	210 (285) 240 (325)
3/4 - 10 - 16	270 (366) 295 (400)	280 (380)	375 (508) 420 (569)
7/8 - 9 - 14	395 (536) 435 (590)	440 (597)	605 (820) 675 (915)
1 - 8 - 14	590 (800) 660 (895)	660 (895)	910 (1234) 990 (1342)

METRIC BOLT & NUT TORQUE SPECIFICATIONS					
Bolt Dia.	Wrench Size	Grade 4.6 Ft-Lb (Nm)	Grade 4.8 Ft-Lb (Nm)	Grade 8.8 - 9.8 Ft-Lb (Nm)	Grade 10.9 Ft-Lb (Nm)
M3	5.5 mm	0.3 (0.5)	0.5 (0.7)	1 (1.3)	1.5 (2)
M4	7 mm	0.8 (1.1)	1 (1.5)	2 (3)	3 (4.5)
M5	8 mm	1.5 (2.5)	2 (3)	4.5 (6)	6.5 (9)
M8	10 mm	3 (4)	4 (5.5)	7.5 (10)	11 (15)
M9	13 mm	7 (9.5)	10 (13)	18 (25)	35 (26)
M10	16 mm	14 (19)	18 (25)	37 (50)	55 (75)
M12	18 mm	26 (35)	33 (45)	63 (85)	97 (130)
M14	21 mm	37 (50)	55 (75)	103 (140)	151 (205)
M16	24 mm	59 (80)	85 (115)	159 (215)	232 (315)
M18	27 mm	81 (110)	118 (160)	225 (305)	321 (435)
M20	30 mm	118 (160)	166 (225)	321 (435)	457 (620)
M22	33 mm	159 (215)	225 (305)	435 (590)	620 (840)
M24	36 mm	203 (275)	288 (390)	553 (750)	789 (1070)
M27	41 mm	295 (400)	417 (565)	811 (1100)	1154 (1565)
M30	46 mm	402 (545)	568 (770)	1103 (1495)	1571 (2130)
M33	51 mm	546 (740)	774 (1050)	1500 (2035)	2139 (2900)
M36	55 mm	700 (950)	992 (1345)	1925 (2610)	2744 (3720)

NOTE: Formula to convert Ft-Lbs to Nm (Newton Meters) multiply Ft-Lb x 1.356.

SEALANTS & LUBRICANTS

GASKETS/SEALANTS

Oil based PERMATEX #2 and it's HIGH TACK equivalent are excellent all purpose sealers. They are effective in just about any joint in contact with coolant, raw water, oil or fuel.

A light coating of OIL or LIQUID TEFLON can be used on rubber gaskets and O-rings.

LOCTITE hydraulic red sealant should be used on oil adapter hoses and the oil filter assembly.

Coat both surfaces of the oil pan gasket with high temp RED SILICONE sealer.

When installing gaskets that seal around water (coolant) passages, coat both sides with WHITE SILICONE grease.

High-copper ADHESIVE SPRAYS are useful for holding gaskets in position during assembly.

Specialized gasket sealers such as HYLOMAR work well in applications requiring non-hardening properties. HYLOMAR is particularly effective on copper cylinder-head gaskets as it resists fuel, oil and water.

Use LIQUID TEFLON for sealing pipe plugs and fillings that connect coolant passages. **Do not use tape sealants!**

BOLTS & FASTENERS/ASSEMBLIES

Lightly oil head bolts and other fasteners as you assemble them. Bolts and plugs that penetrate the water jacket should be sealed with PERMATEX #2 or HIGH TACK.

When assembling the flywheel, coat the bolt threads with LOCTITE blue.

Anti-seize compounds and thread locking adhesives such as LOCTITE protect threaded components yet allows them to come apart when necessary. LOCTITE offers levels of locking according to the job.

LITHIUM based grease is waterproof, ideal for water pump bearings and stuffing boxes.

Heavily oil all sliding and reciprocating components when assembling. **Always use clean engine oil!**



90A FOUR TORQUE SPECIFICATIONS

Component	ft - lb	kg - m	Component	ft - lb	kg - m
Alternator bracket	27 - 38	3.8 - 5.3	Injection pipe flare nut	18 - 22	2.5 - 3.0
Back plate	27 - 38	3.8 - 5.3	Injector to head.....	12 - 17	1.6 - 2.4
Camshaft thrust plate	14 - 19	1.9 - 2.6	Intake manifold.....	14 - 19	1.9 - 2.6
Connecting rod cap	59 - 65	8.2 - 9.0	Main bearing cap	72 - 77	10.0 - 10.7
Coolant temperature sender.....	18 - 29	2.5 - 4.0	Oil filter	8.0 - 9.4	1.1 - 1.3
Coolant temperature switch	18 - 29	2.5 - 4.0	(or tighten firmly by hand)		
Crankshaft pulley nut	253 - 289	35.0 - 40.0	Oil pan bolts	14 - 19	1.9 - 2.6
Cylinder head bolts	DO NOT TORQUE		Oil pan drain plug	36.2 - 43.4	5.0 - 6.0
Cylinder head cover.....	1.4 - 2.5	0.2 - 0.35	Oil pump pipe	5.8 - 8.0	0.8 - 1.1
Damper	16 - 24	2.2 - 3.4	Oil pressure sender	9 - 13	1.2 - 1.8
Engine mounts	23 - 34	3.2 - 4.7	Oil pressure switch	9 - 13	1.2 - 1.8
Exhaust manifold	17 - 20	2.3 - 2.7	Rear oil seal cap	14 - 19	1.9 - 2.6
Flywheel	130 - 145	18 - 20	Rocker arm assembly.....	14 - 19	1.9 - 2.6
Coolant pump bolts	9 - 13	1.2 - 1.8	Thermostat housing	5.8 - 8.0	0.8 - 1.1
Idler gear.....	14 - 19	1.9 - 2.6	Timing gear case	12 - 17	1.6 - 2.4
Injection pump drive gear	29 - 52	4.0 - 9.0	Timing gear cover.....	14 - 19	1.9 - 2.6

Conversion factor to get Nm:
 Ft-Lb x 1.356 = Nm



32 KW BEDA GENERATOR SPECIFICATIONS

SPECIFICATIONS	
Engine Type	Diesel, four-cycle, four-cylinder, fresh water-cooled, Vertical, in-line overhead valve mechanism (46 hp at 1800 rpm maximum).
Aspiration	Naturally aspirated.
Governor	Electronic Governing
Combustion Chamber	Swirl type
Bore & Stroke	3.94 x 4.33 inches (100.1 x 110.0 mm)
Piston Displacement	210.8 cubic inches (3.5 liters)
Firing Order	1 - 3 - 4 - 2
Direction of Rotation	Clockwise, when viewed from the front
Maximum Torque (at 1800 rpm)	166 lb-ft (23 kg-m)
Compression Ratio	18:1
Dimensions	Height: 30.0 inches (762.0 mm) Width: 22.0 inches (558.8 mm) Length: 44.6 inches (113.3 mm)
Weight	1038 lbs (471.8 kgs)
TUNE-UP SPECIFICATIONS	
Compression Pressure (Limit of difference between cylinders)	427 psi (30 kg/cm ²) at 200 rpm 47.2 psi (3.0 kg/cm ²)
Valve Timing	Intake Opens 19° BTDC Intake Closes 47° ABDC Exhaust Opens 52° BBDC Exhaust Closes 14° ATDC
Engine Timing	Static timed - drop valve method 0.180 ± .005 inches BTDC
Injector Pressure	2450 ± 35 psi (1 + 5-0 kg/cm ²)
Valve Seat Angle	Intake 45° Exhaust 30°
Valve Clearance (engine cold)	Intake 0.012 inches (0.3 mm) Exhaust 0.014 inches (0.35 mm)
Engine Speed	1800 RPM 60 Hertz 1500 RPM 50 Hertz

FUEL SYSTEM	
General	Open flow, self priming - 1 bleed point
Fuel	No. 2 diesel oil (cetane rating of 45 or higher)
Fuel Injection Pump	ZEXEL Model PE (In-Line)
Fuel Injection Timing	12° BTDC
Nozzle	Orifice type
Fuel Filter (on engine)	Full Flow Replaceable
Air cleaner	Metal screen type - cleanable
Air Flow (engine combustion)	110 cfm (3.1 cmm)
COOLING SYSTEM	
General	Fresh water-cooled block, thermostatically-controlled with heat exchanger.
Operating Temperature	170 - 190° F (77 - 88° C)
Fresh Water Pump	Centrifugal type, metal impeller, belt-driven
Raw Water Pump	Positive displacement, rubber impeller, belt driven.
Raw Water Flow, at 1800 rpm	15.0 gpm (56.7 lpm) (measured before discharging into exhaust elbow).
System Capacity (fresh water)	8.5 qts (8.04 liters)
LUBRICATION SYSTEM	
General	Pressure fed system
Oil Filter	Full flow, paper element, spin-on type
Sump Capacity (not including filter)	6.3 U.S. qts (6.0 liters) plus filter/cooler assembly
Operating Oil Pressure (engine hot)	30 - 35 psi (2.1 - 2.5 kg/cm ²)
Oil Grade	API Specification of CF or CG-4, SAE 30, 10W-30, 15W-40

(continued)



32 KW BEDA GENERATOR SPECIFICATIONS

ELECTRICAL SYSTEM

Starting Battery	12-Volt, (-) negative ground
Battery Capacity	600 - 900 Cold Cranking Amps (CCA)
DC Charging Alternator	51 Amp rated, belt-driven
Starter	12-Volt, 3 KW
Starting Aid	Glow plugs, sheathed type .1 - .2 ohm
DC No-Load Current	± 2% of rated Amps
DC Cranking Current	250 - 300 Amps (engine cold)

AC GENERATOR (SINGLE PHASE)

General - Single Phase	Brushless, four-pole, revolving field Sealed lubricated single bearing design. Reconnectable single phase for 120/240 volts with solid state voltage regulator.
Voltage - Single Phase	120 or 120/240 Volts - 60 Hertz 230 Volts - 50 Hertz
Voltage regulation:	± 2% no load to full load.
Frequency regulation:	.3 Hertz no load to full load.
Rating (Volts AC)	32 KW - 60 Hertz (1800 rpm) 120 Volts 266 Amps 120/240 Volts 266/133 Amps 25 KW - 50 Hertz (1500 rpm) 230 Volts 108.7 Amps

AC GENERATOR (3 Phase)

General - 3 Phase 20.0 KW - 60 Hertz 16.0 KW - 50 Hertz	Brushless six pole, revolving field. Sealed lubricated single bearing design. 12 Lead reconnectable for low voltage WYE and for Delta. Solid State voltage regulator with protection circuitry.	
Voltage - 3 Phase (60 Hertz)	Low voltage WYE	208 volts
	High voltage WYE	480 volts
	DELTA	240 volts
Voltage - 3 Phase (50 Hertz)	High voltage WYE	380 volts
	DELTA	230 volts
Amperage - 3 Phase (60 Hertz)	Low voltage WYE	111.0 Amps
	High voltage WYE	48.1 Amps
.8 power factor	DELTA	96.2 Amps
Amperage - 3 Phase (50 Hertz)	High voltage WYE	47.5 Amps
.8 power factor	DELTA	82.0 Amps

GENERATOR COOLING

Air Requirements (60 Hertz at 1800 RPM)	1.0 power factor 500 cfm (15.0 cmm)
Note: Increase air supply 15% for 50 Hertz operation 1500 rpm	
Engine Combustion Air Requirements (60 Hertz at 1800 RPM)	110 cfm (3.1 cmm)



32 KW BEDA GENERATOR PARTS IDENTIFICATION

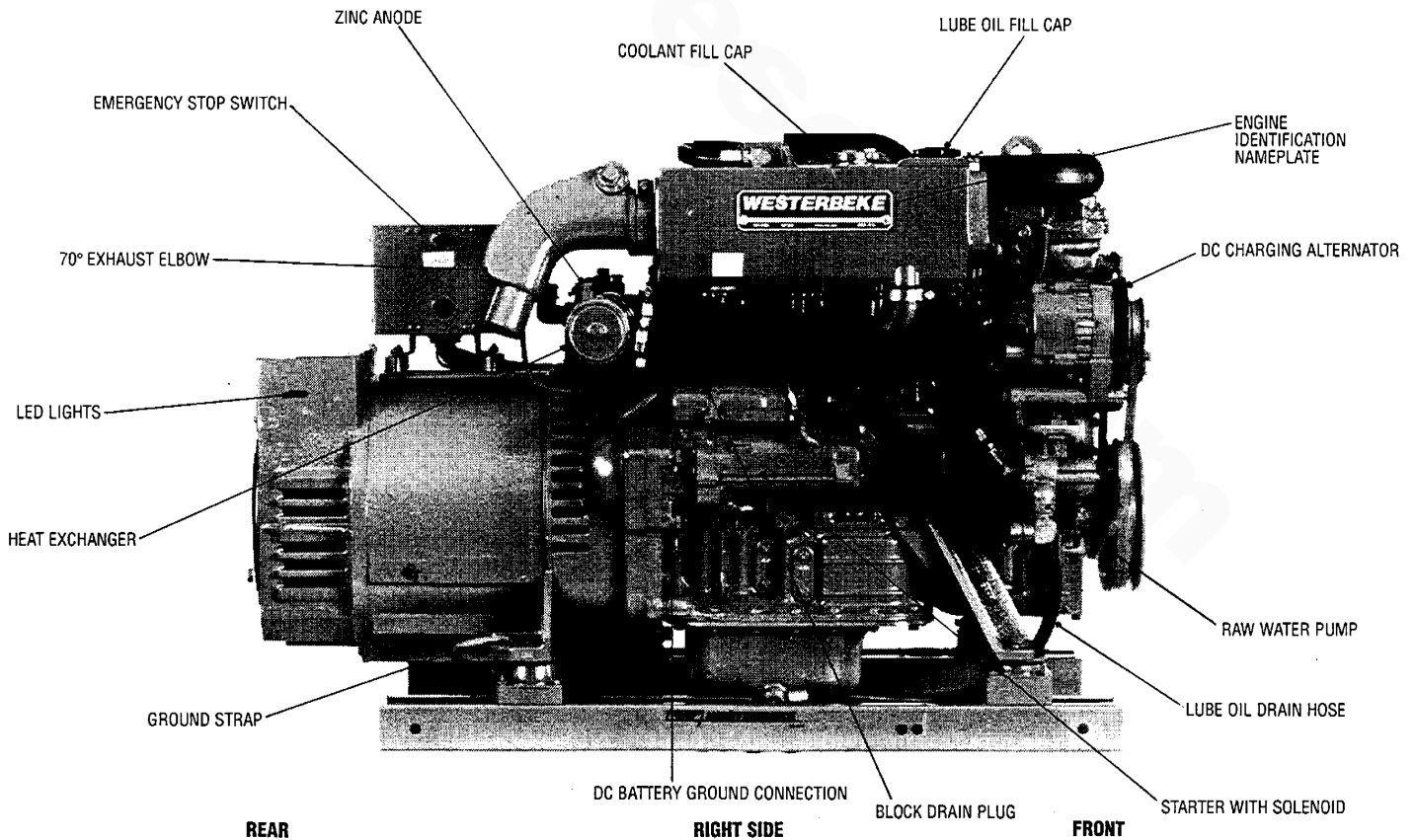
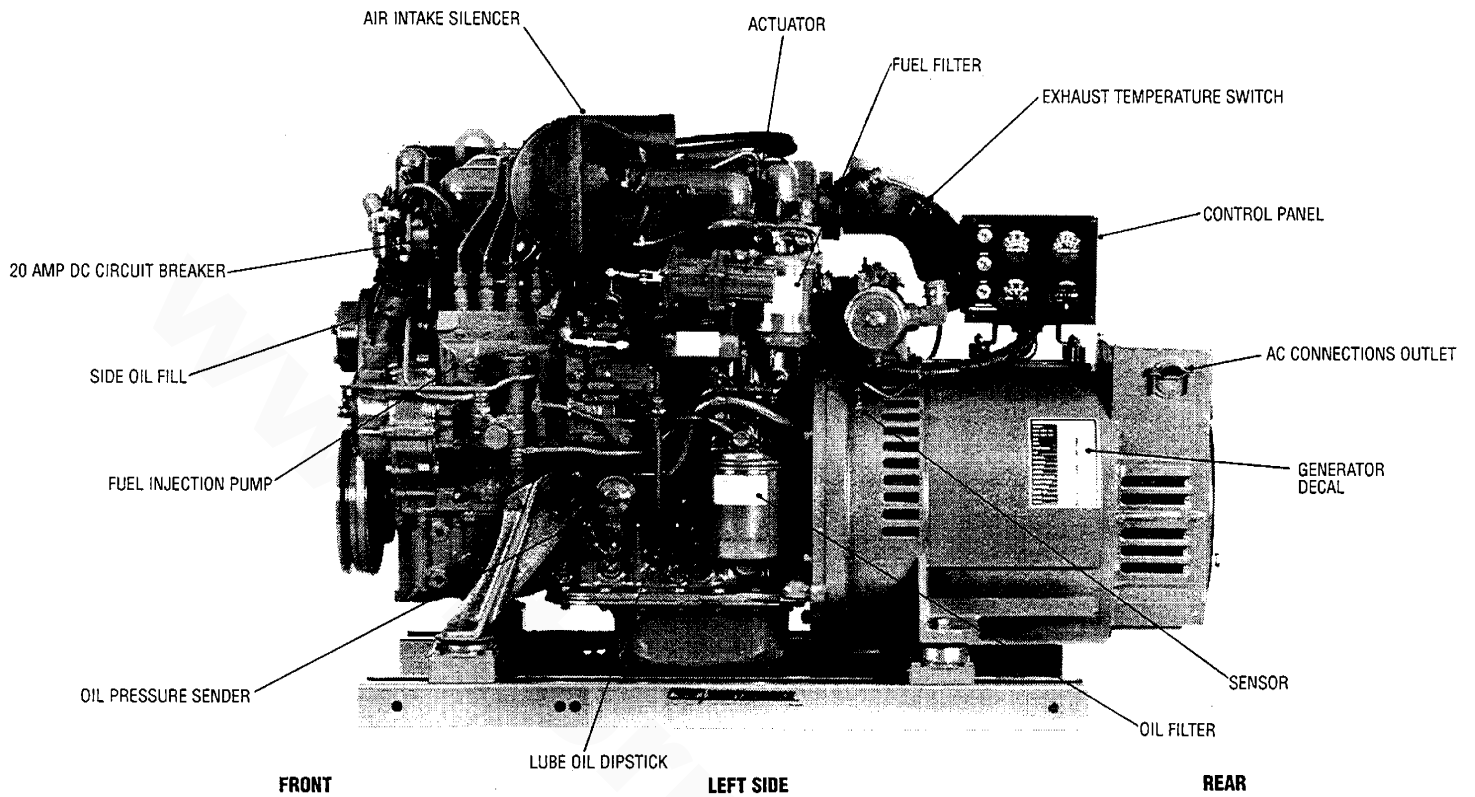

GENERATOR INFORMATION

USE OF ELECTRIC MOTORS

The power required to start an electric motor is considerably more than is required to keep it running after it is started. Some motors require much more current to start them than others. Split-phase (AC) motors require more current to start, under similar circumstances, than other types. They are commonly used on easy-starting loads, such as washing machines, or where loads are applied after the motor is started, such as small power tools. Because they require 5 to 7 times as much current to start as to run, their use should be avoided, whenever possible, if the electric motor is to be driven by a small generator. Capacitor and repulsion-induction motors require from 2 to 4 times as much current to start as to run. The current required to start any motor varies with the load connected to it. An electric motor connected to an air compressor, for example, will require more current than a motor to which no load is connected.

In general, the current required to start 115-Volt motors connected to medium starting loads will be approximately as follows:

MOTOR SIZE (HP)	AMPS FOR RUNNING (AMPERES)	AMPS FOR STARTING (AMPERES)
1/6	3.2	6.4 to 22.4*
1/4	4.6	9.2 to 32.2*
1/3	5.2	10.4 to 72.8*
1/2	7.2	14.4 to 29.2*
3/4	10.2	20.4 to 40.8*
1	13	26 to 52

***NOTE:** In the above table the maximum Amps for Starting is more for some small motors than for larger ones. The reason for this is that the hardest starting types (split-phase) are not made in larger sizes.

Because the heavy surge of current needed for starting motors is required for only an instant, the generator will not be damaged if it can bring the motor up to speed in a few seconds. If difficulty is experienced in starting motors, turn off all other electrical loads and, if possible, reduce the load on the electric motor.

Required Operating Speed

Run the generator first with no load applied, then at half the generator's capacity, and finally loaded to its full capacity as indicated on the generator's data plate. The output voltage should be checked periodically to ensure proper operation of the generating plant and the appliances it supplies. If an AC voltmeter or ampmeter is not installed to monitor voltage and load, check it with a portable meter and amprobe.

NOTE: When the vessel in which the generator is installed contains AC equipment of 120 volts only, it is recommended that the generator's AC terminal block be configured to provide one 120 volt AC hot leg for the vessel's distribution panel. This will ensure good motor starting response from the generator.

Generator Frequency Adjustment

Frequency is a direct result of engine/generator speed, as indicated by the following:

- When the generator is run at 1800 rpm, the AC voltage output frequency is 60 Hertz.
- When the generator is run at 1500 rpm, the AC voltage output frequency is 50 Hertz.

Therefore, to change the generator's frequency, the generator's drive engine's speed must be changed. Along with a reconfiguring of the AC output connections at the generator, a regulator board voltage output adjustment must also be made. See *ELECTRONIC GOVERNOR* in this manual.

Generator Maintenance

- Maintaining reasonable cleanliness is important. Connections of terminal boards and rectifiers may become corroded, and insulation surfaces may start conducting if salts, dust, engine exhaust, carbon, etc. are allowed to build up. Clogged ventilation openings may cause excessive heating and reduced life of windings.
- For unusually severe conditions, thin rust-inhibiting petroleum-base coatings, should be sprayed or brushed over all surfaces to reduce rusting and corrosion.
- In addition to periodic cleaning, the generator should be inspected for tightness of all connections, evidence of overheated terminals and loose or damaged wires.
- The drive discs on single bearing generators should be checked periodically if possible for tightness of screws and for any evidence of incipient cracking failure. Discs should not be allowed to become rusty because rust may accelerate cracking. The bolts which fasten the drive disc to the generator shaft must be hardened steel SAE grade 8, identified by 6 radial marks, one at each of the 6 corners of the head.
- The rear armature bearing is lubricated and sealed; no maintenance is required. However, if the bearing becomes noisy or rough-sounding, have it replaced.
- Examine bearing at periodic intervals. No side movement of shaft should be detected when force is applied. If side motion is detectable, bearings are wearing or wear on shaft of bearing socket outside bearing has occurred. Repair must be made quickly or major components will rub and cause major damage to generator.

Carbon Monoxide Detector

WESTERBEKE recommends mounting a carbon monoxide detector in the vessels living quarters. **Carbon monoxide, even in small amounts is deadly.**

The presence of carbon monoxide indicates an exhaust leak from the engine or generator, from the exhaust elbow/exhaust hose, or that fumes from a nearby vessel are entering your boat.

If carbon monoxide is present ventilate the area with clean air and correct the problem immediately!



GENERATOR CONTROL PANEL SWITCHES

DESCRIPTION

This manually controlled series of WESTERBEKE marine diesel generators is equipped with toggle switches on the engine control panel and, optionally, at remote panels. The following instructions and methods of correcting minor problems apply only to such toggle switch controls.

All three switches are momentary contact type and serve the following functions:

- 1. PREHEAT:** The PREHEAT toggle switch is a double pole, single throw switch. The switch serves two purposes: pre-heating the engine for easy starting and defeating of bypassing the engine oil pressure switch. The defeat function turns on the fuel solenoid, instrument power and alternator excitation.

When the PREHEAT switch is depressed, the voltmeter, panel lights, gauges and meters and fuel solenoid will activate. The PREHEAT switch should be depressed for twenty seconds.

- 2. STOP:** The STOP toggle switch is a single pole, single throw, normally closed switch. The switch provides power to the fuel solenoid, instrument cluster and alternator excitation, after the oil pressure switch has closed upon starting. Opening of this switch opens the power circuit to the fuel solenoid, stopping the flow of fuel to the engine and shuts down the engine.

To stop the engine, depress the STOP switch. When the STOP switch is depressed, the power feed to the fuel solenoid is opened, and the fuel flow to the engine is stopped. The STOP switch should be depressed until the generator stops rotating.

- 3. START:** The START toggle switch is a double pole, single throw switch. The switch serves two purposes: starting the engine and defeating of bypassing the engine oil pressure switch. The defeat function turns on the fuel solenoid, instrument power and alternator excitation. While the PREHEAT switch is still depressed, depressing the START switch engages the start solenoid. Panel power and the fuel solenoid will be activated. When the engine begins to fire, the START switch should be released. The PREHEAT switch should not be released until the oil pressure reaches alarm stops.

NOTE: When the engine is shut down, the water temperature gauge and the oil pressure gauge will continue to register the last temperature and oil pressure readings displayed. They will return to zero once electrical power is restored.

- 4. EMERGENCY STOP:** The EMERGENCY stop switch at the rear of the control box is normally closed. When depressed, it will open the DC circuit to the control panel and shut the engine down. As the switch is not toggled it can be used when performing maintenance.

REMOTE PANEL

For remote operation of the generator system, the same three switches are used. The PREHEAT and START switches are connected in parallel with the gauge panel's switches and serve the same functions as in the gauge panel. The STOP switch is in series with the gauge panel's STOP switch and serves the same function.

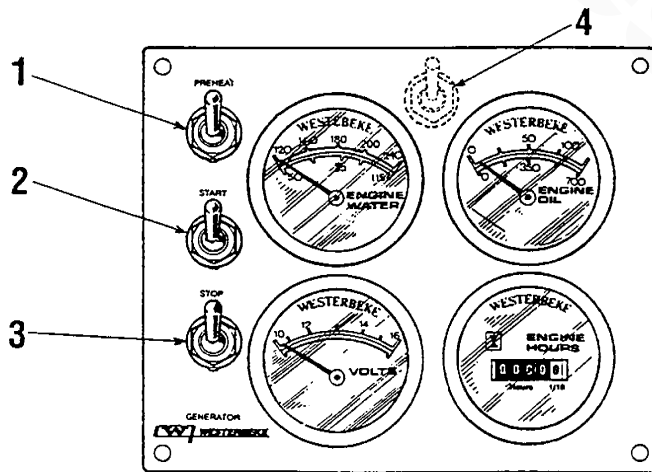

CONTROL PANEL

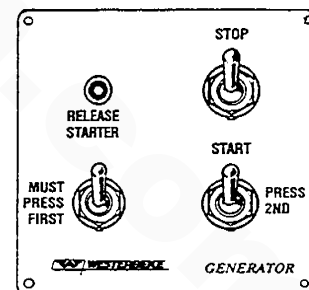

REMOTE PANEL (OPTIONAL)



CONTROL PANEL TROUBLESHOOTING MANUAL STARTER DISCONNECT (TOGGLE SWITCHES)

NOTE: *The engine control system is protected by a 20 amp manual reset circuit breaker located on the engine as close as possible to the power source.*

Problem	Probable Cause	Verification/Remedy
PREHEAT depressed, no panel indications electric fuel pump and preheat solenoid not energized. cuit	<ol style="list-style-type: none"> 1. Oil Pressure switch. 2. 20 amp circuit breaker tripped. 	<ol style="list-style-type: none"> 1. Check switches and/or battery connections. 2. Reset breaker. If it opens again, check preheat solenoid circuit and run circuit for shorts to ground.
START SWITCH DEPRESSED , no starter engagement.	<ol style="list-style-type: none"> 1. Connection to solenoid faulty. 2. Low DC voltage to solenoid terminal. 3. Faulty switch. 4. Faulty solenoid. 5. Loose battery connections. 6. Low battery. 	<ol style="list-style-type: none"> 1. Check connection. 2. Check voltage. Jump voltage to S terminal. 3. Check switch with ohmmeter. 4. Check that 12 volts are present at the solenoid connection. 5. Check battery connections. 6. Check battery charge state.
NO IGNITION , cranks, does not start.	<ol style="list-style-type: none"> 1. Faulty fueling system. 2. Check for air in the fuel system. 3. Faulty fuel lift pump. 4. Faulty fuel solenoid. 	<ol style="list-style-type: none"> 1. Check for fuel. 2. Allow system to bleed. 3. Replace fuel lift pump. 4. Check fuel solenoid.
NOT CHARGING BATTERY	<ol style="list-style-type: none"> 1. Faulty alternator drive. 	<ol style="list-style-type: none"> 1. Check the drive belt and its tension. Be sure the alternator turns freely. Check for loose connections. Check the output with a voltmeter. Ensure 12V are present at the regulator terminal.(Exc. Terminal.)
BATTERY RUNS DOWN	<ol style="list-style-type: none"> 1. Oil pressure switch. 2. High resistance leak to ground. 	<ol style="list-style-type: none"> 1. Observe if the gauges and panel lights are activated when the engine is not running. Test the oil pressure switch. 2. Check the wiring. Insert sensitive (0-.25 amp) meter in battery lines (Do NOT start engine). Remove connections and replace after short is located.

TROUBLESHOOTING WATER TEMPERATURE AND OIL PRESSURE GAUGES

If the gauge reading is other than what is normally indicated by the gauge when the instrument panel is energized, the first step is to check for 12 volts DC between the ignition (B+) and the Negative (B-) terminals of the gauge.

Assuming that there is 12 volts as required, leave the instrument panel energized and perform the following steps:

1. Disconnect the sender wire at the gauge and see if the gauge reads zero, which is the normal reading for this situation.
2. Connect the sender terminal at the gauge to ground and see if the gauge reads full scale, which is the normal reading for this situation.

If both of the above gauge tests are positive, the gauge is undoubtedly OK and the problem lies either with the conductor from the sender to the gauge or with the sender.

If either of the above gauge tests are negative, the gauge is probably defective and should be replaced.

Assuming the gauge is OK, check the conductor from the sender to the sender terminal at the gauge for continuity.

Check that the engine block is connected to the ground. Some starters have isolated ground terminals and if the battery is connected to the starter (both plus and minus terminals), the ground side will not necessarily be connected to the block.



THE BE GENERATOR SINGLE AND THREE PHASE

DESCRIPTION

This generator is a four-pole, brushless, self-excited generator which requires only the driving force of the engine to produce AC output. The copper and laminated iron in the exciter stator are responsible for the self-exciting feature of this generator. The magnetic field produced causes an AC voltage to be induced into the related exciter rotor windings during rotation. Diodes located in the exciter rotor rectify this voltage to DC and supply it to the windings of the rotating field. This creates an electromagnetic field which rotates through the windings of the main stator, inducing an AC voltage which is supplied to a load. An AC voltage is produced in the auxiliary windings of the main stator and is, in turn, supplied to a voltage regulator. The regulator produces a DC voltage to further excite the exciter stator windings, enabling the generator to produce a rated AC output. The voltage regulator senses AC voltage output and adjusts DC excitation to the exciter stator winding according to amperage load the generator is furnishing. To maintain a constant voltage output.

CIRCUIT BREAKER

A circuit breaker is installed on all WESTERBEKE generators. This circuit breaker will automatically disconnect generator power in case of an electrical overload. The circuit breaker can be manually shut off when servicing the generator to ensure that no power is coming into the boat.

NOTE: This circuit breaker is available as a WESTERBEKE add-on kit for earlier model generations; contact your WESTERBEKE dealer.

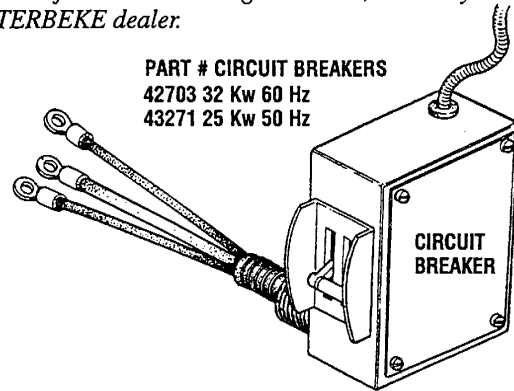

PART # CIRCUIT BREAKERS
42703 32 Kw 60 Hz
43271 25 Kw 50 Hz

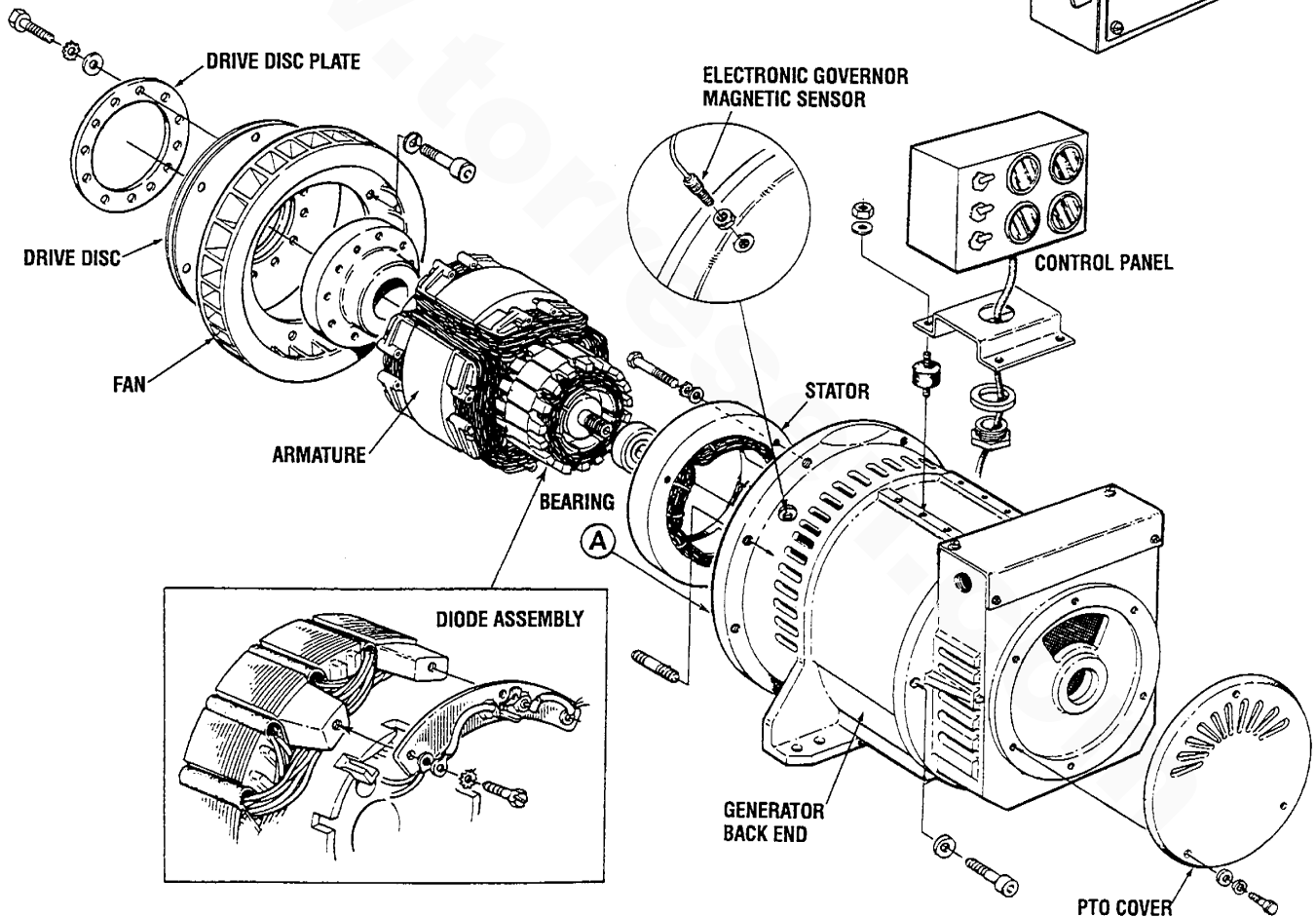

GENERATOR AC VOLTAGE CONNECTIONS

DESCRIPTION

The regulator is equipped with seven numbered terminals (0 to 6) and their related brass jumpers. The illustrations show connection points and jumpers for the 3 phase configuration of the generator. The sensing leads connect between pin #1 and pin #2 on the AC terminal block and connection #2 and #0 on the voltage regulator board.

NOTE: Series Delta requires the installation of a jumper on the regulator board between terminal B and 1.

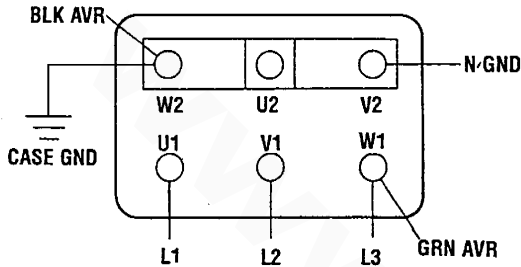

**BE THREE PHASE (SIX WIRE)
CONNECTIONS FOR BOTH 60 & 50 HERTZ**

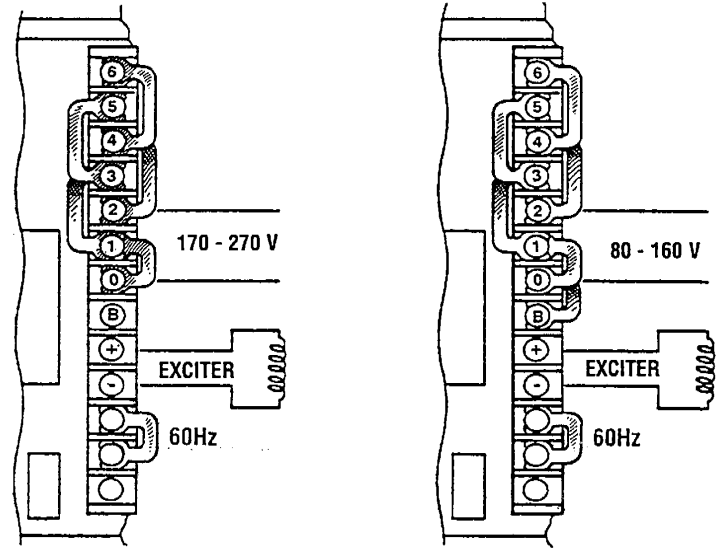

3 PHASE VOLTAGE REGULATOR

NOTE: IF WIRING FOR 50 HZ., THE 60 HZ. JUMPER MUST BE REMOVED FROM THE REGULATOR.

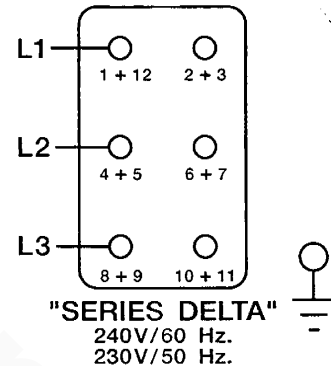
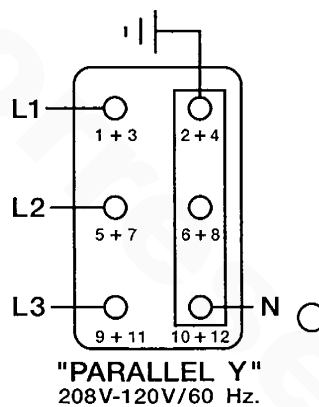
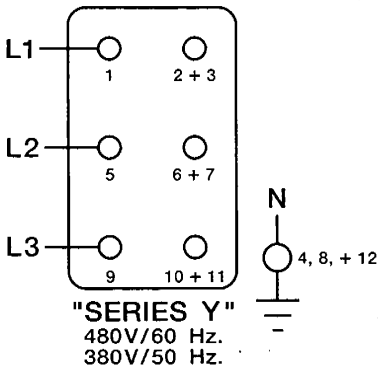

6 STUD 3 PHASE AC WIRING

PARALLEL WYE (STAR)

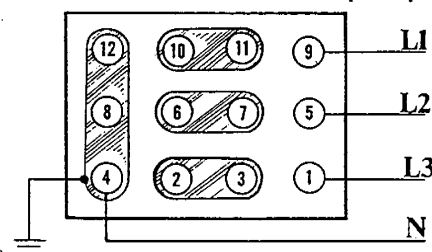

L - L - 208 VAC 3Ø 60 Hz
L - N - 120 VAC 1Ø 60 Hz
L - L - 190 VAC 3Ø 50 Hz
L - N - 110 VAC 1Ø 50 Hz

SERIES WYE (STAR)

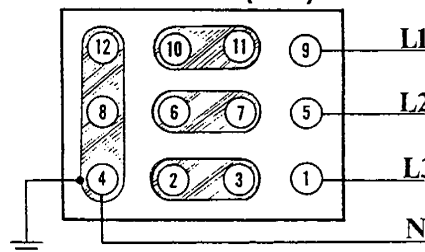

L - L - 450 VAC 3Ø 60Hz
L - N - 265 VAC 1Ø 60 Hz
L - L - 380 VAC 3Ø 50Hz
L - N - 230 VAC 1Ø 50Hz

SERIES DELTA

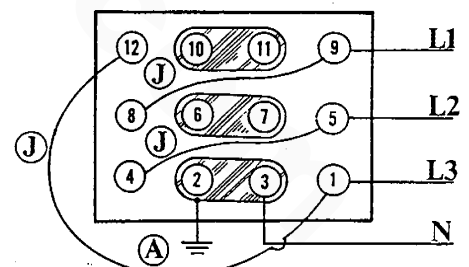

L - L - 240 VAC 2Ø 60Hz
L2, L3-N - 120 VAC 1Ø 60Hz
L - L - 230 VAC 3Ø 50Hz
L2, L3-N - 115 VAC 1Ø 50Hz

BE THREE PHASE (TWELVE WIRE)

A. SERIES DELTA-Note the repositioning of the ground lead from neutral to generator housing.

J. Jumper using #10 AWG



GENERATOR AC VOLTAGE CONNECTIONS

AC VOLTAGE CONNECTIONS

NOTE: The frame ground wire (white/green) must be properly positioned when changing the AC output configuration of the AC terminal block. For making connections to the AC terminal block, use terminal ends for 1/4 inch studs that will accept multi strand copper wire sized for the amperage rating from the hot lead connection. The frame ground wire is white or white with a green strip. It connects between the neutral stud and the generator frame.

Generator Frequency

1. Frequency is a direct result of engine/generator speed: 1800 rpm = 60 hertz; 1500 rpm = 50 hertz.
2. To change generator frequency, follow the steps below:
Configure the AC terminal block for the desired voltage frequency as shown. Ensure that the case ground wire is connected to the correct terminal block neutral ground stud.

NOTE: The white/green ground wire may be removed in those installations where the AC circuit has a separate neutral and ground circuit. This will prevent the unit from being a ground source in the vessel.

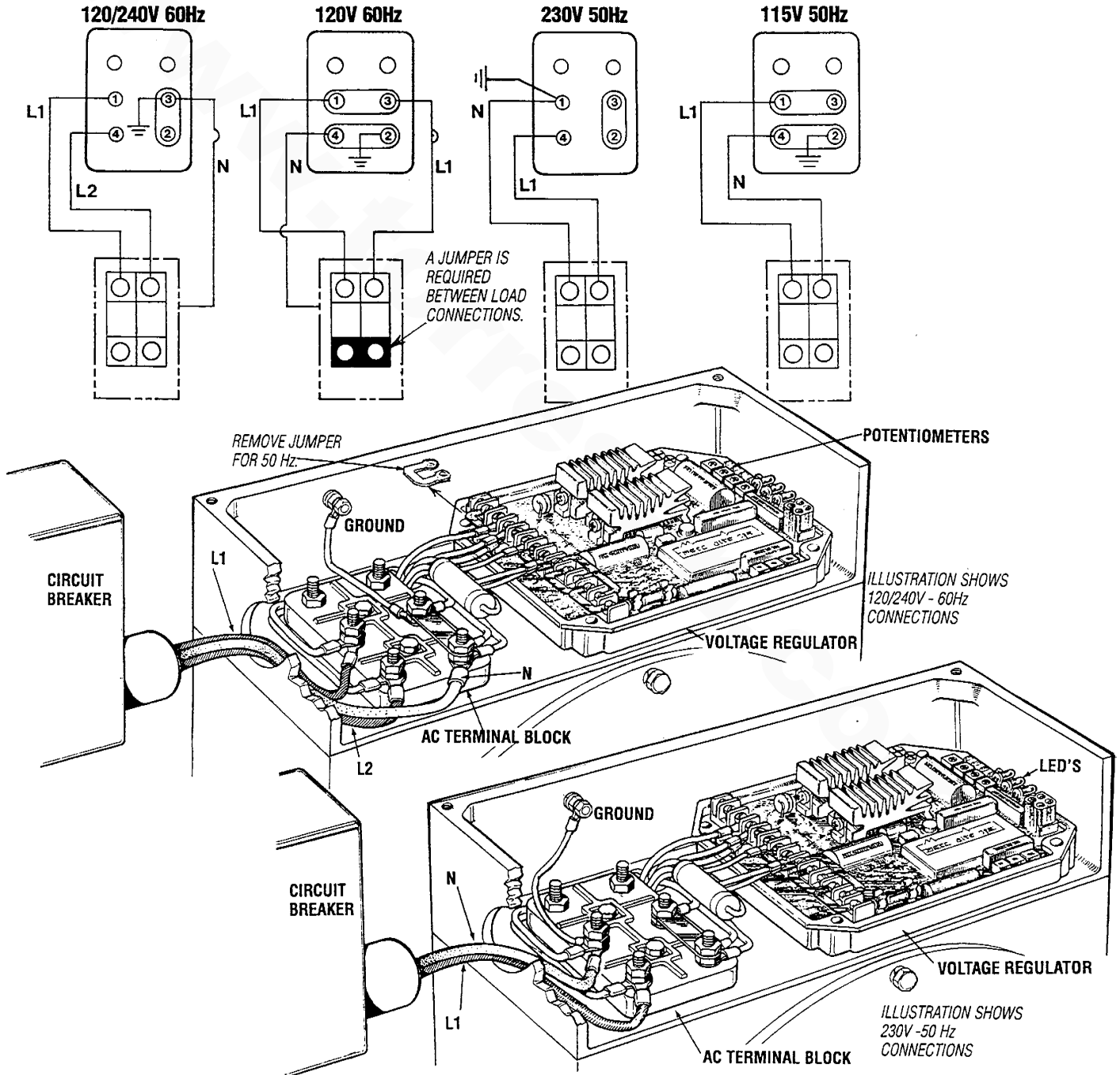

VOLTAGE REGULATOR ADJUSTMENTS

Description

The voltage regulator is an advanced design which ensures optimum AC alternator performance. It is equipped with complete protection circuitry to guard against operating conditions that could be detrimental to the AC alternator.

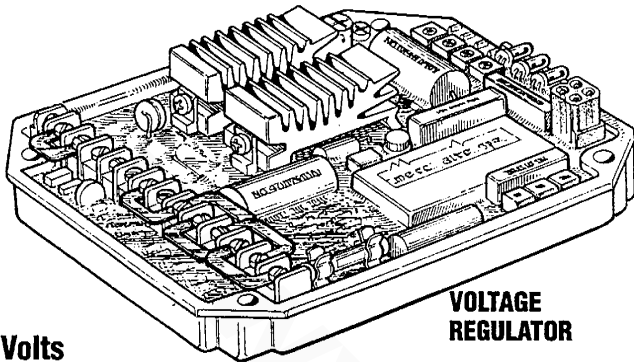

**VOLTAGE
REGULATOR**

Volts

This potentiometer is used to adjust output voltage. At proper engine operating speed the output voltage should be held at $\pm 1\%$ from a no-load condition to a full rated generator output and from power factor 1.0 - 0.8 with engine drive speed variations up to -6%.

Prior to starting the engine, turn the VOLT and STAB trimmers (using a mini phillips screwdriver) fully in a counter clockwise (Minimum) direction until you feel them hit their stops.

Turn the AMP and HERTZ trimmers completely clockwise (Maximum) in the same manner.

With the alternator running at no-load, at normal speed, and with VOLT adjust at minimum, it is possible that output voltage will oscillate. Slowly rotate the VOLT adjust clockwise. The voltage output of the alternator will increase and stabilize. Increase the voltage to the desired value. In this situation, only the green LED will stay lit.

Stability

This potentiometer permits variation of the regulator's response to generator load changes so as to limit overcompensation and obtain a minimum recovery time to the normal voltage output.

In order to adjust the regulator stability the alternator must be running at no-load and the output must be monitored.

Turn the STAB adjust slowly clockwise until the voltage starts to fluctuate. At this point rotate the STAB adjust counterclockwise until the voltage is stable within 1 or 2 tenths of a volt.

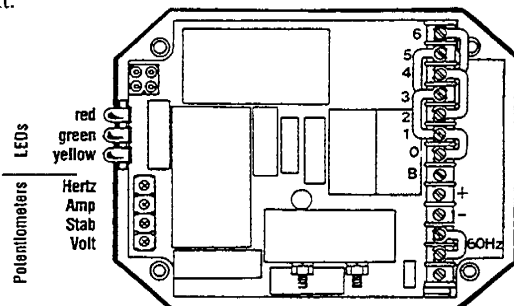

VOLTAGE REGULATOR DIAGRAM

Amp-Hertz

These two adjustments are used in conjunction with the two protection circuits in the voltage regulator that are indicated by the illumination of a colored LED lights.

1. Delayed overload protection (yellow LED).
2. Low speed protection (red LED).

Both systems have an intervention threshold which can be adjusted using the respective potentiometer. Each of the two circuits are able to cause an adequate reduction in excitor voltage to safeguard the excitor windings and prevent their overheating.

The overload protection system has a delay which permits temporary overloading of the generator during times such as motor start-up or other similar load surge demands. The regulator also has a third LED (green), that glows during generator operation to indicate correct operation of the regulator with the generator.

Setting the Overload Protection

In order to set the AMP overload protection, the alternator must be loaded to its full output rating.

1. Load the alternator to its rating, then decrease the speed of the engine by 10.10% (54 Hertz on 60 hertz units, 45 hertz on 50 hertz units).
2. Rotate the AMP adjustment counterclockwise until it hits its stop. Wait about 15-20 seconds after which the AC output of the alternator should drop and the yellow LED light should come on.
3. Slowly rotate the AMP adjustment clockwise until the output voltage increases to approximately 97% of the voltage output at the start of the adjustment. At this point the yellow LED light should come on.
4. Return to nominal speed, the yellow LED will turn off and the alternator voltage will rise to its normal value. Should this not happen, repeat the adjustment.

NOTE: When changing from 60 hertz to 50 hertz operation, remove the 60 hertz jumper bar from the regulator board.

Setting the Underspeed Protection

NOTE: If the unit is operating at 60 Hertz ensure that the jumper strap is in place on the regulator board between the two 60 Hertz terminals. In order to adjust the underspeed setting, the alternator should be running at no-load.

1. To adjust the underspeed (low frequency) protection circuit, lower the engine speed at 90% of its normal running speed (54 hertz on 60 hertz units, 45 hertz on 50 hertz units).
2. Rotate the Hertz adjustment counterclockwise slowly until the alternator's AC output voltage starts to decrease and at the same time the red "LED" light comes on.
3. Increase the engine speed to its normal speed (frequency). The red "LED" light will go out and the AC voltage output will return to normal.

With the above adjustments made, the regulator should function normally.



INTERNAL WIRING SCHEMATICS SINGLE PHASE

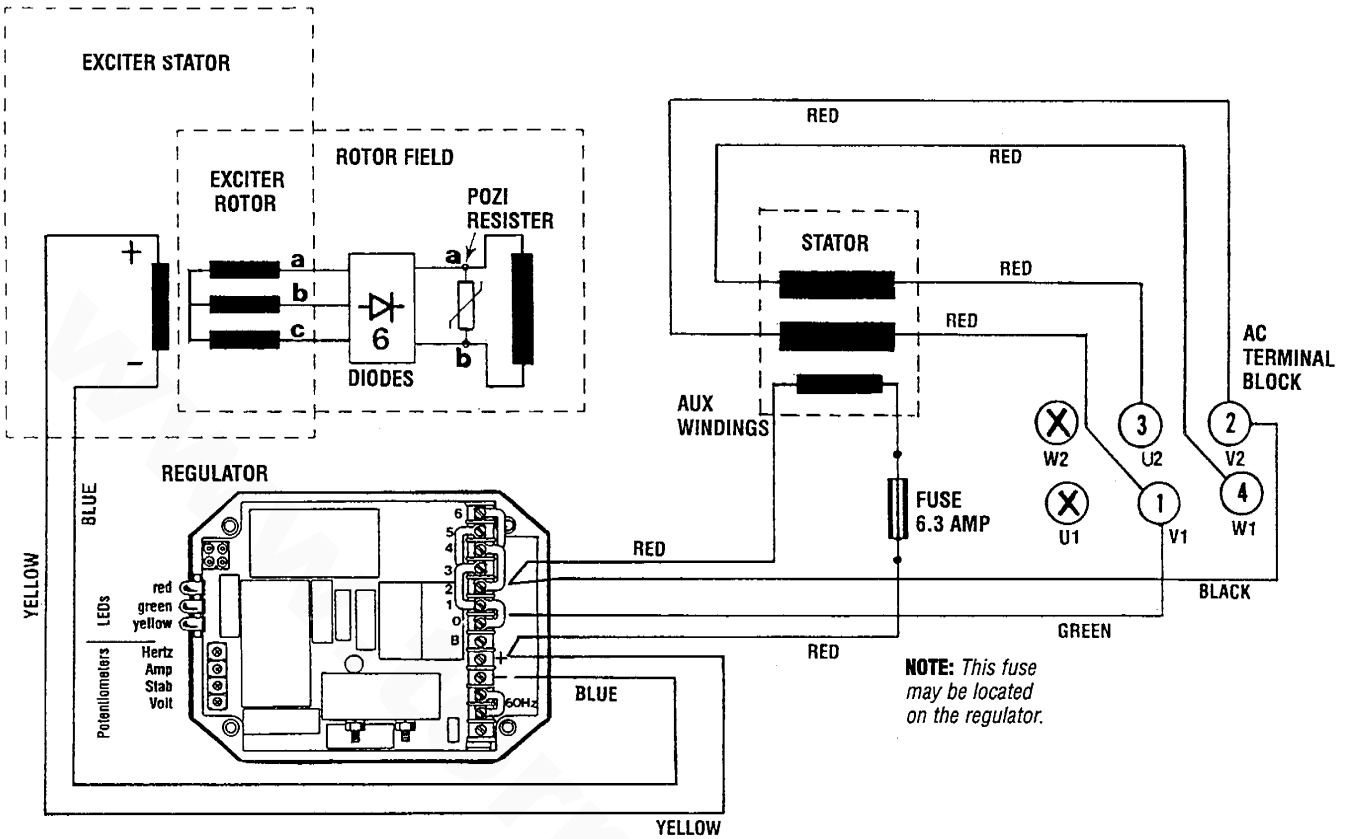

THREE PHASE 6 WIRE RECONNECTABLE

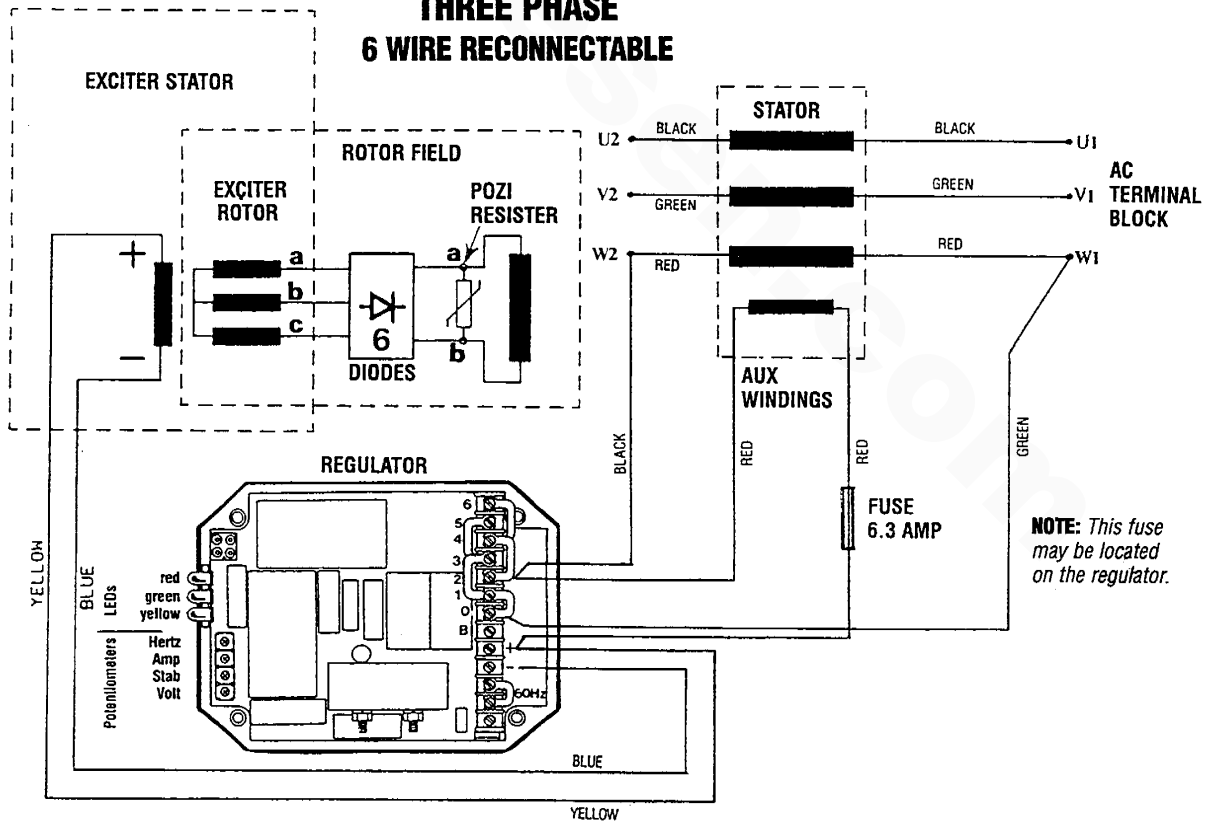

INTERNAL WIRING SCHEMATICS

3 PHASE TWELVE WIRE RECONNECTABLE

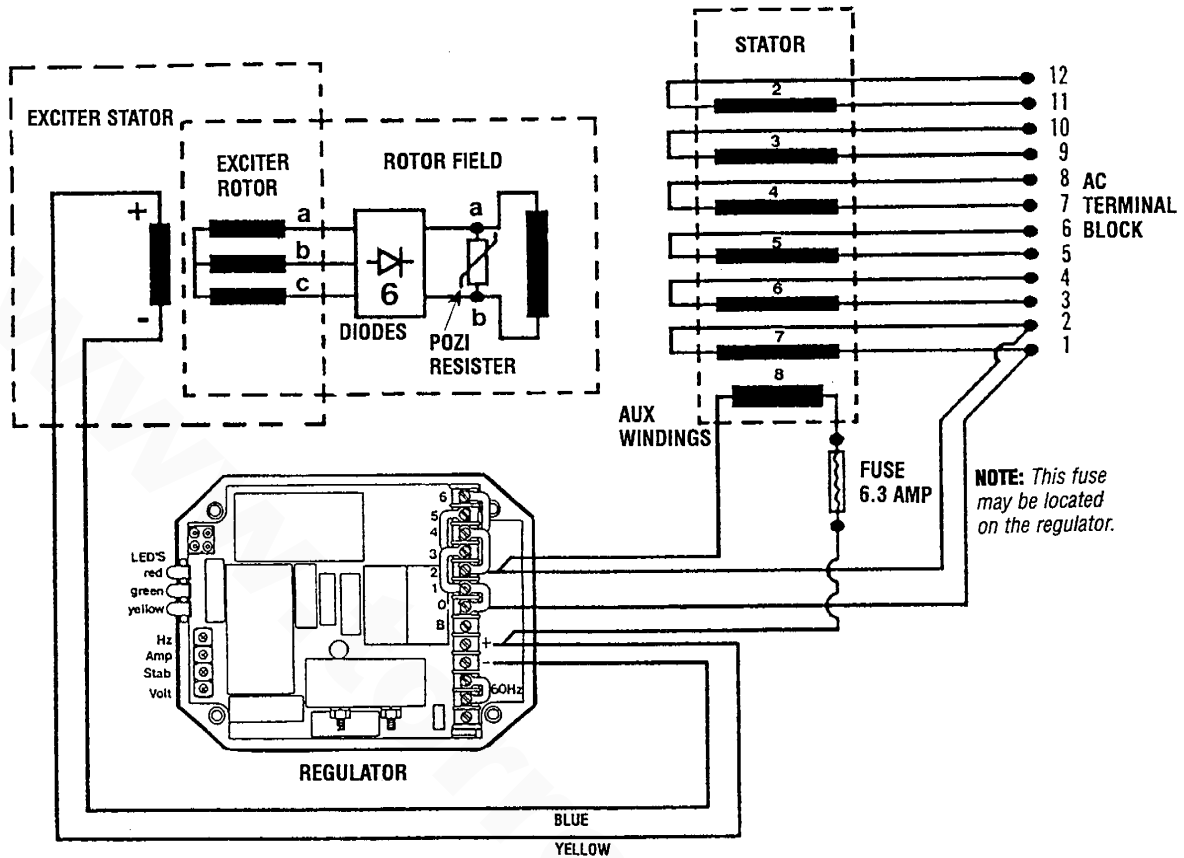

BE GENERATOR WINDING RESISTANCE VALUES (IN OHMS)

	SINGLE PHASE	20 & 25 BE	32 BE
EXCITER STATOR		18.06	18.20
EXCITER ROTOR	a - b	0.68	0.72
	b - c	0.68	0.72
ROTATING FIELD		1.75	2.01
MAIN STATOR	1 - 2	0.05	0.05
	3 - 4	0.05	0.05
AUXILLARY WINDING		1.19	0.98

	THREE PHASE	20, 25, & 32 BE
EXCITER STATOR		18.20
EXCITER ROTOR	a - b	0.7
	b - c	0.7
ROTATING FIELD		2.01
MAIN STATOR		0.06 (each winding)
AUXILLARY WINDING		0.98



BE TROUBLESHOOTING

NOTE: AC GENERATOR TROUBLESHOOTING MUST BE PERFORMED WITH ENGINE OPERATING AT 60 HERTZ.

PROBLEM	PROBABLE CAUSE	
No AC voltage output at no load.	<ol style="list-style-type: none"> 1. Short or open in the main stator winding. 2. Shorted pozi-resistor on exciter rotor. 3. Four or more shorted or open diodes on exciter rotor. 	<ol style="list-style-type: none"> 4. Short or open in exciter stator winding. 5. Short or open in rotating field winding.
Residual voltage produced at no load 15 - 20 volts AC.	<ol style="list-style-type: none"> 1. Blown 6 AMP fuse auxiliary circuit feed to AVR. 2. Faulty voltage regulator 	<ol style="list-style-type: none"> 3. Shorted or open main stator auxiliary winding.
Low AC voltage output at no load 60 - 100 VAC.	<ol style="list-style-type: none"> 1. Open or shorted diodes in exciter rotor 1 to 3 diodes. 2. Open or shorted exciter rotor winding 	<ol style="list-style-type: none"> 3. Faulty voltage regulator.
High AC output voltage 150 VAC or higher.	<ol style="list-style-type: none"> 1. Faulty voltage regulator. 	
Unstable voltage output.	<ol style="list-style-type: none"> 1. STB pod on regulator needs adjustment. 	<ol style="list-style-type: none"> 2. Faulty voltage regulator.
AC voltage drop under load 60 - 100 volts AC.	<ol style="list-style-type: none"> 1. Diode(s) on exciter rotor breaking down when load is applied (inductive) 1-3 diodes. 	

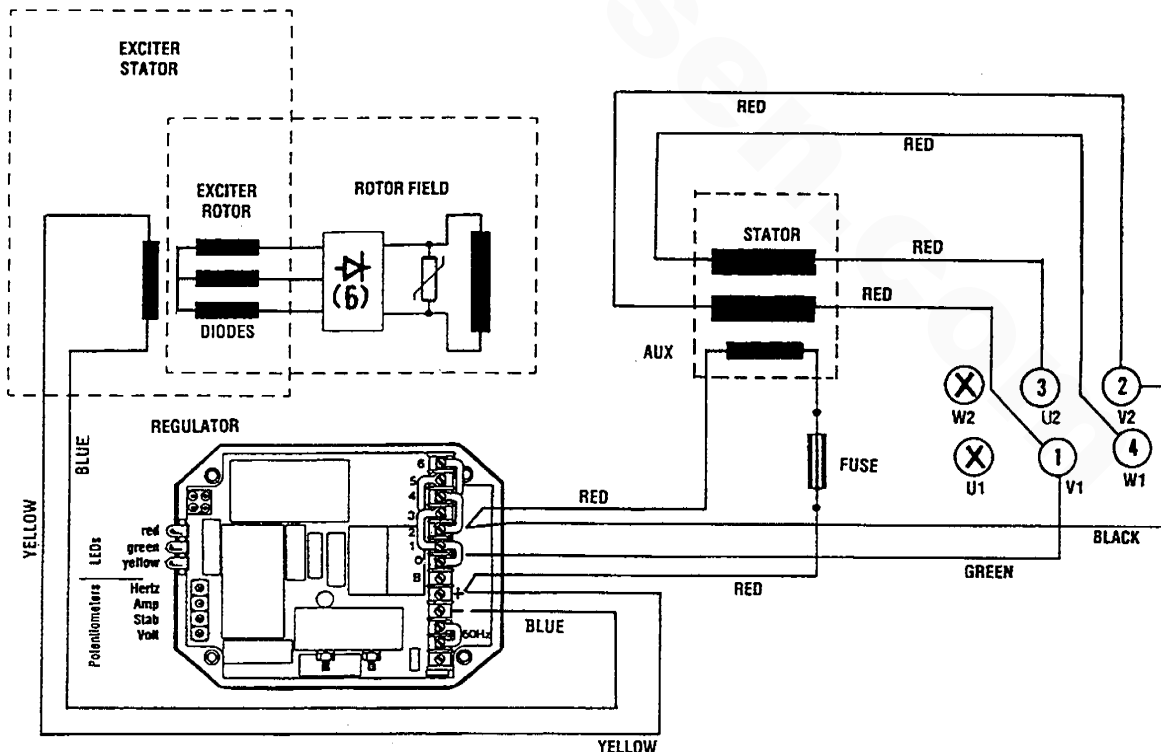

ELECTRONIC GOVERNOR

Electronic Governor System

The system is composed of three basic components:

1. **Controller.** Mounted in the instrument panel.
2. **Sensor.** Installed on the bellhousing over the flywheel ring gear.
3. **Actuator.** Mounted at the front of the engine and attached with linkage to the throttle arm of the injection pump.

Controller Adjustment

1. **Speed.** This adjustment is used to raise or lower the engine's speed to the desired hertz.
2. **Gain.** This adjustment affects the reaction time of the actuator to the generator/engine load changes.

NOTE: A high gain adjustment can induce an oscillating of the actuator producing a hunting mode. In such cases, lessen the gain adjustment.

Calibration

1. With no power to the governor, adjust the GAIN to 9:00 o'clock.
2. Start the engine and adjust the speed by turning the speed pot clockwise to desired speed.

NOTE: Controllers are factory adjusted to minimum rpm. However, for safety, one should be capable of disabling the engine if an overspeed should exist.

3. At no-load, turn the GAIN potentiometer clockwise until the engine begins to hunt. If the engine does not hunt, physically upset the governor linkage.
4. Turn the GAIN potentiometer counterclockwise until stable.

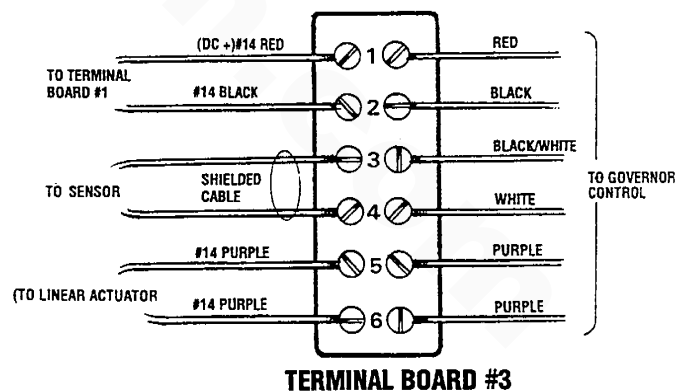
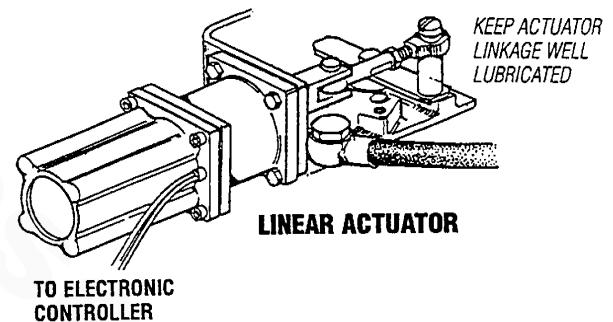
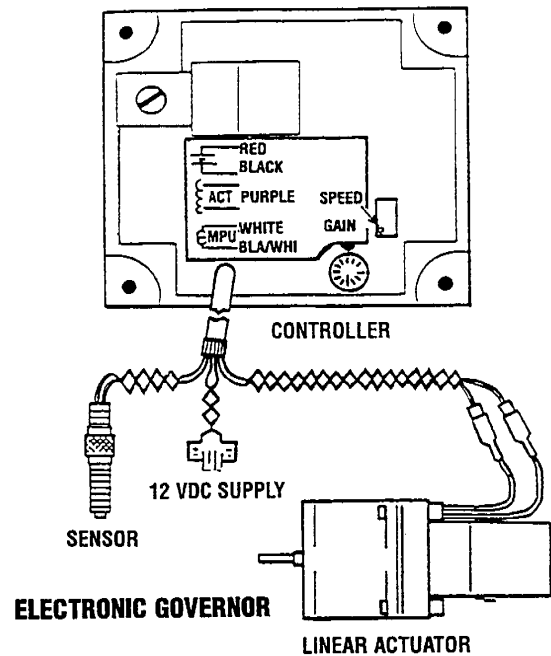
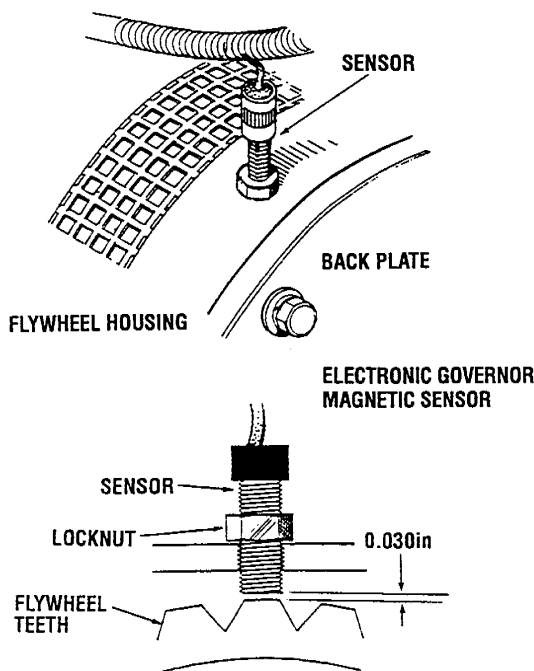

TROUBLESHOOTING THE ELECTRONIC GOVERNOR

Problem	Probable Cause	Verification/Remedy
System appears dead (Engine runs at idle.)	<ol style="list-style-type: none"> 1. Low battery voltage at controller. 2. Stuck linkage. 3. No signal or weak signal from sensor. Measure AC voltage from sensor while engine is running at idle. Voltage should be 1.5 volts or greater. 4. Check Actuator – depress PREHEAT and check for battery voltage between negative black lead at terminal block. <ol style="list-style-type: none"> a. Purple lead to black. b. Second purple to black. 5. Perform the following check between terminals at the actuator and the negative DC lead at the controller terminal block. (Preheat depressed). <ol style="list-style-type: none"> a. Low voltage (1.20-2.0 VDC) at either actuator connection. b. Battery voltage at both actuator connections. c. Battery voltage at one actuator lead but not the other. 	<ol style="list-style-type: none"> 1. Check wiring for cause. Check battery state of charge. 2. Lubricate, free up linkage between controller and throttle arm. 3. Check for improperly installed or damaged sensor in flywheel housing. Replace or adjust. 4. Replace controller if battery voltage is not present at both leads. <ol style="list-style-type: none"> a. Broken actuator lead. b. Broken actuator lead. c. Replace the actuator.
Actuator fully extends when PREHEAT is depressed and stays extended.	<ol style="list-style-type: none"> 1. Check controller. Lift one of the purple actuator leads from the terminal block. Depress PREHEAT. <ol style="list-style-type: none"> a. Actuator fully extends. b. Actuator does not fully extend and connections. <p>NOTE: Release PREHEAT and reconnect the purple lead.</p>	<ol style="list-style-type: none"> a. Short in lead to actuator. b. Replace controller.
Actuator hunts (oscillates) and engine running.	<ol style="list-style-type: none"> 1. Linkage between actuator and throttle binding. 2. Improper adjustment of GAIN on controller. 3. Inadequate DC power supply to controller, complete the following tests: Connect a DC voltmeter across the plus and negative leads at the controller terminal block. Lift both purple leads from the terminal block. Connect one purple lead to the C plus terminal and the other to the DC negative. Momentarily depress PREHEAT. The actuator should fully extend. 3a. Sensor positioned marginally too far away from flywheel teeth giving erratic signal voltage to controller. 	<ol style="list-style-type: none"> 1. Lubricate/free-up. 2. Lessen GAIN adjustment (Recalibrate the Controller). 3. If actuator does not fully extend, check the actuator leads. If the voltage is less than specified, check for loose or poor connections, low battery voltage, voltage drop in DC circuit due to remote panel installation and small wire sizes making connections. DC voltage registering on the meter should be: 12 VDC System – 9.6 VDC or higher 24 VDC System – 19.2 VDC or higher NOTE: Reconnect actuator leads properly after making this test. 3a. Check the position of the sensor.



SHORE POWER TRANSFER SWITCH

SHORE POWER CONNECTIONS (60 HERTZ)

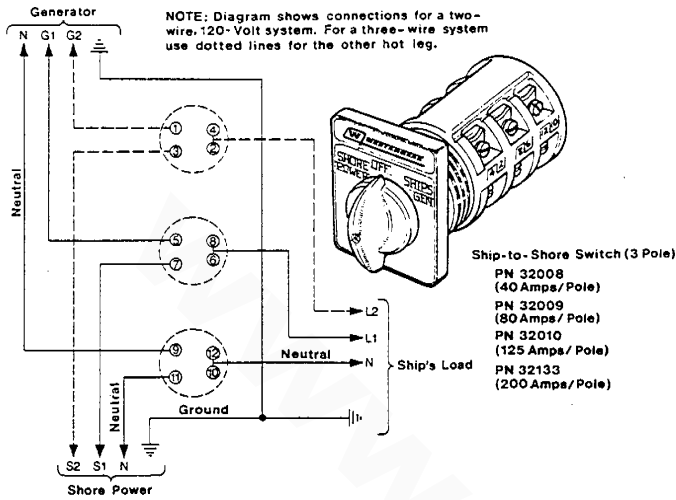

If the installer connects shore power to the vessel's AC circuit, this must be done by means of the Shore Power Transfer Switch. Set the transfer switch shown in the diagrams to the OFF position. This switch prevents simultaneous connection of shore power to generator output.

CAUTION: Damage to the generator can result if utility shore power and generator output are connected at the same time. This type of generator damage is not covered under the warranty; it is the installer's responsibility to make sure all AC connections are correct.

120 VOLT/60 HZ THREE WIRE CONFIGURATION

Notice the repositioning of the white wire ground load on the terminal block to the generator case.

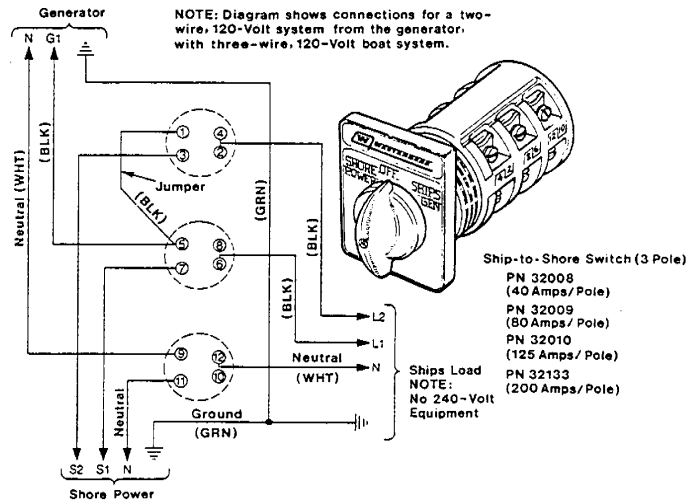

Switching Shore Power to Generator Power

CAUTION: Heavy motor leads should be shut off before switching shore power to generator power or vice-versa because voltage surges induced by switching with heavy AC loads on the vessel being operated may cause damage to the exciter circuit components in the generator.

32 KW BEDA GENERATOR

WIRING DIAGRAM #040425 (SINGLE RELAY)

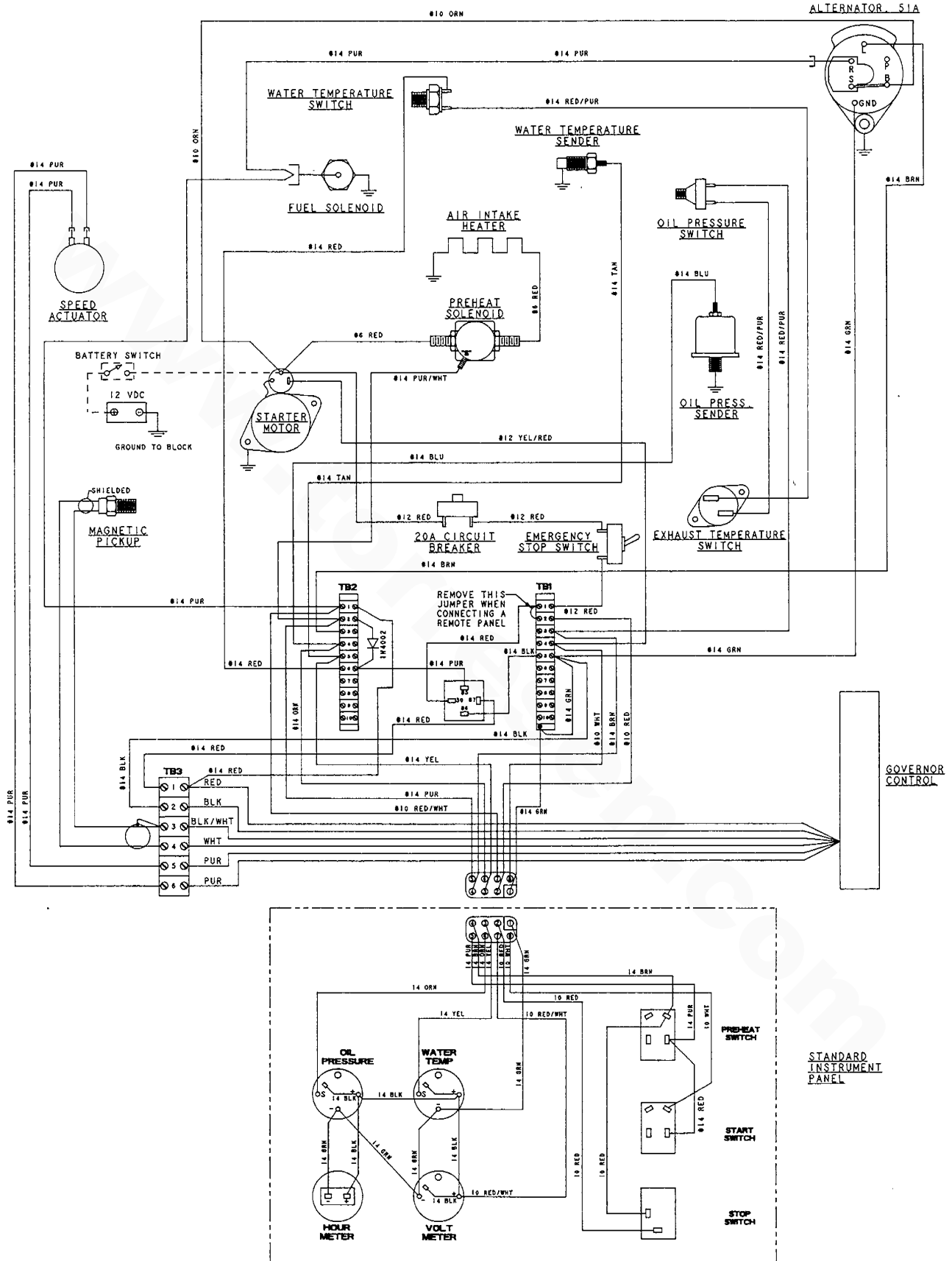

32 KW BEDA GENERATOR WIRING SCHEMATIC #040425 (SINGLE RELAY)

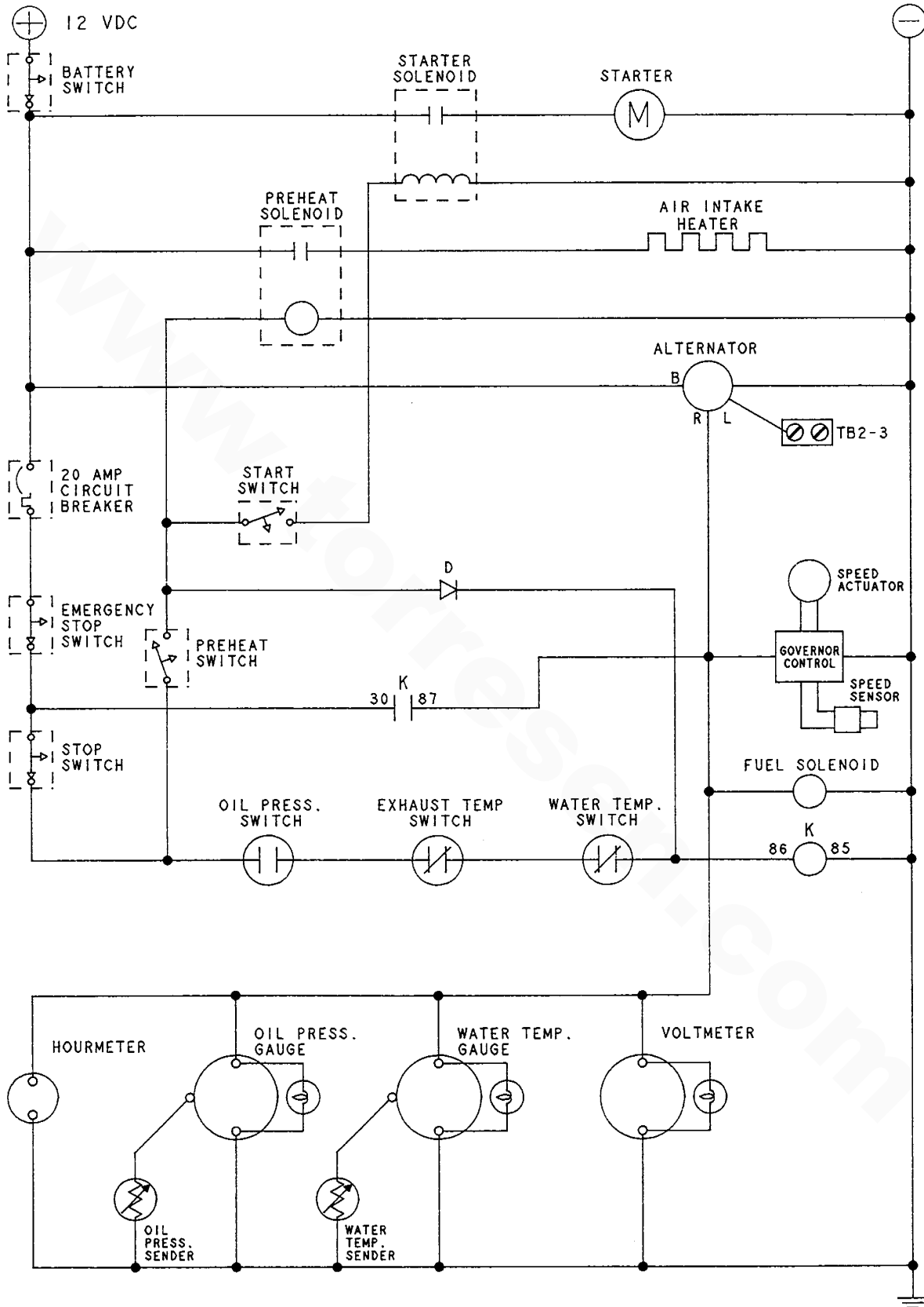

32 KW BEDA GENERATOR

WIRING DIAGRAM #040425 (TWO RELAYS)

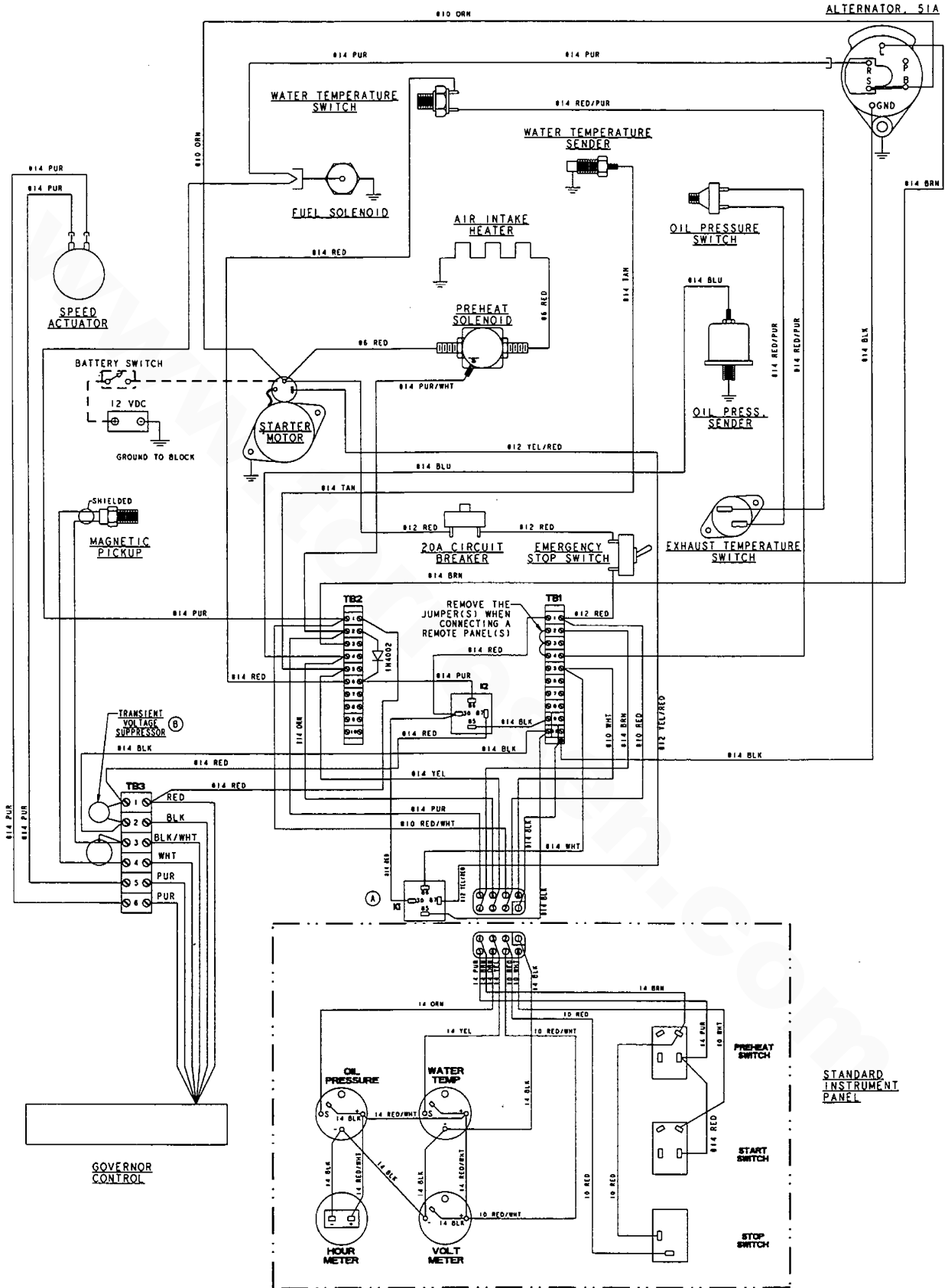

32 KW BEDA GENERATOR WIRING SCHEMATIC #040425 (TWO RELAYS)

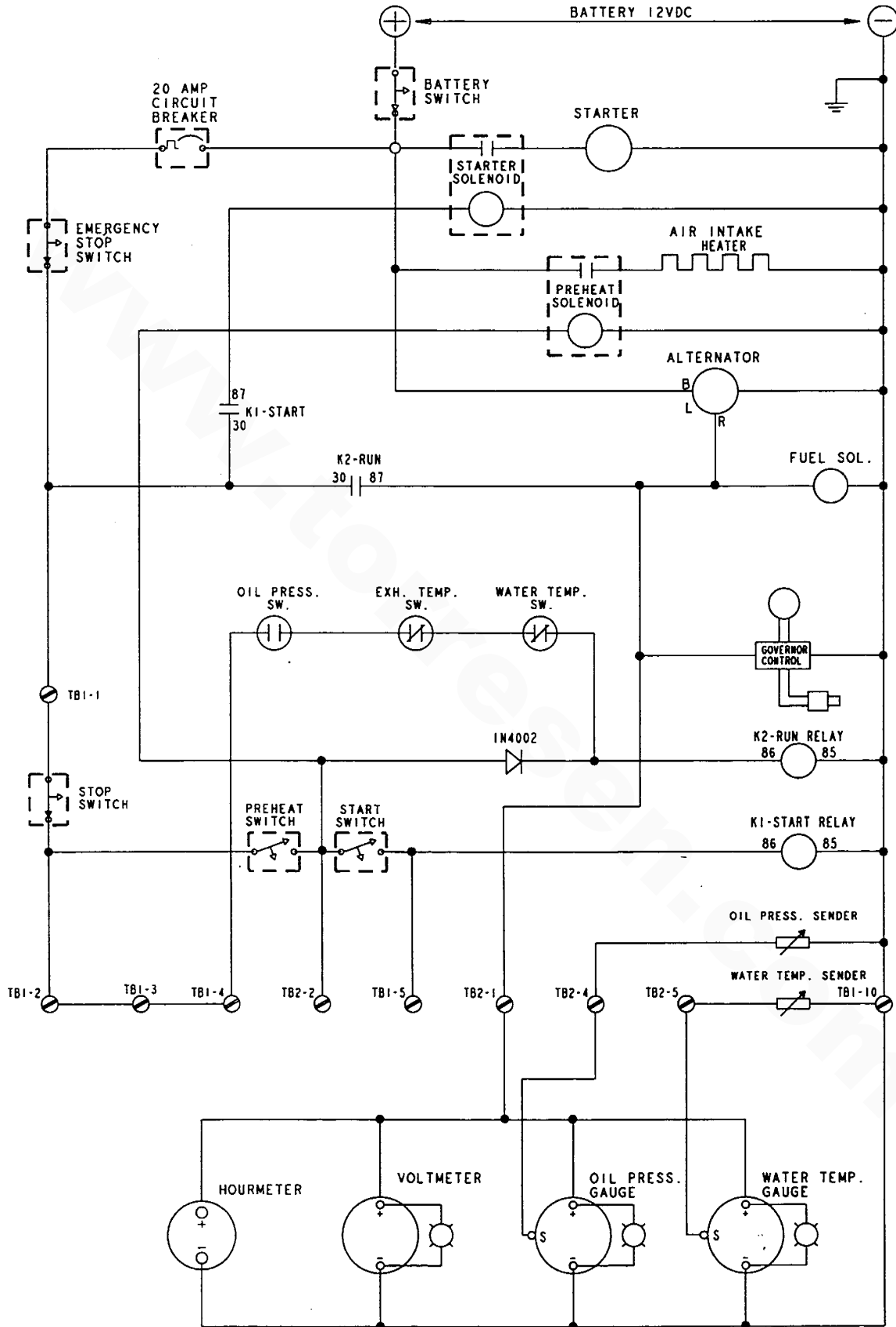

32 KW BEDA GENERATOR

WIRING DIAGRAM #44737 (TWO RELAYS) (PLUG-IN REMOTE START/STOP PANEL)

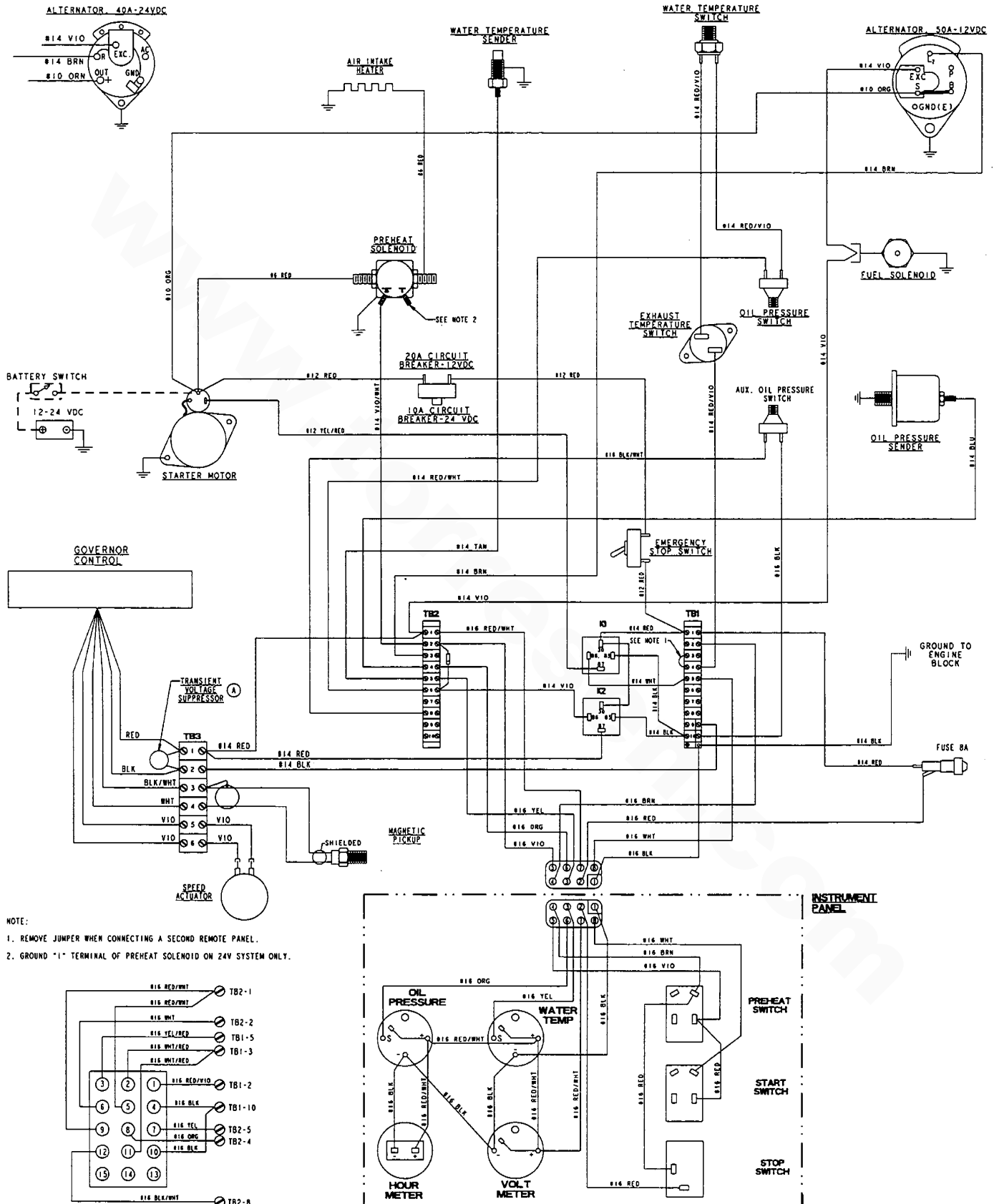

NOTE:
 1. REMOVE JUMPER WHEN CONNECTING A SECOND REMOTE PANEL.
 2. GROUND "1" TERMINAL OF PREHEAT SOLENOID ON 24V SYSTEM ONLY.

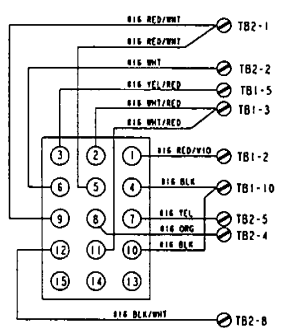

32 KW BEDA GENERATOR

WIRING SCHEMATIC #44737 (TWO RELAYS) (PLUG-IN REMOTE START/STOP PANEL)

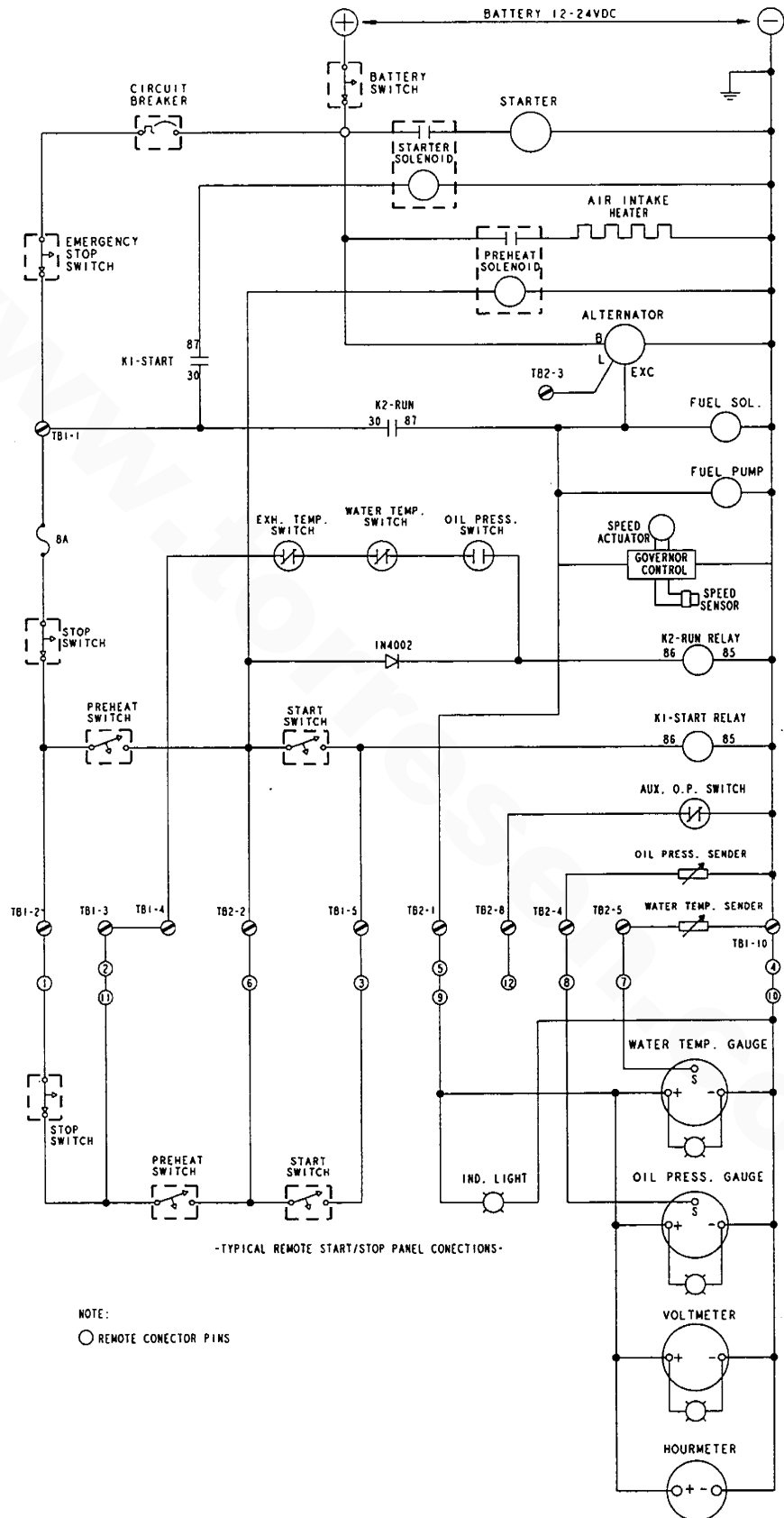

32 KW BEDA GENERATOR

WIRING DIAGRAM #041128 (SINGLE RELAY)

24 VDC SPECIAL SPEC.

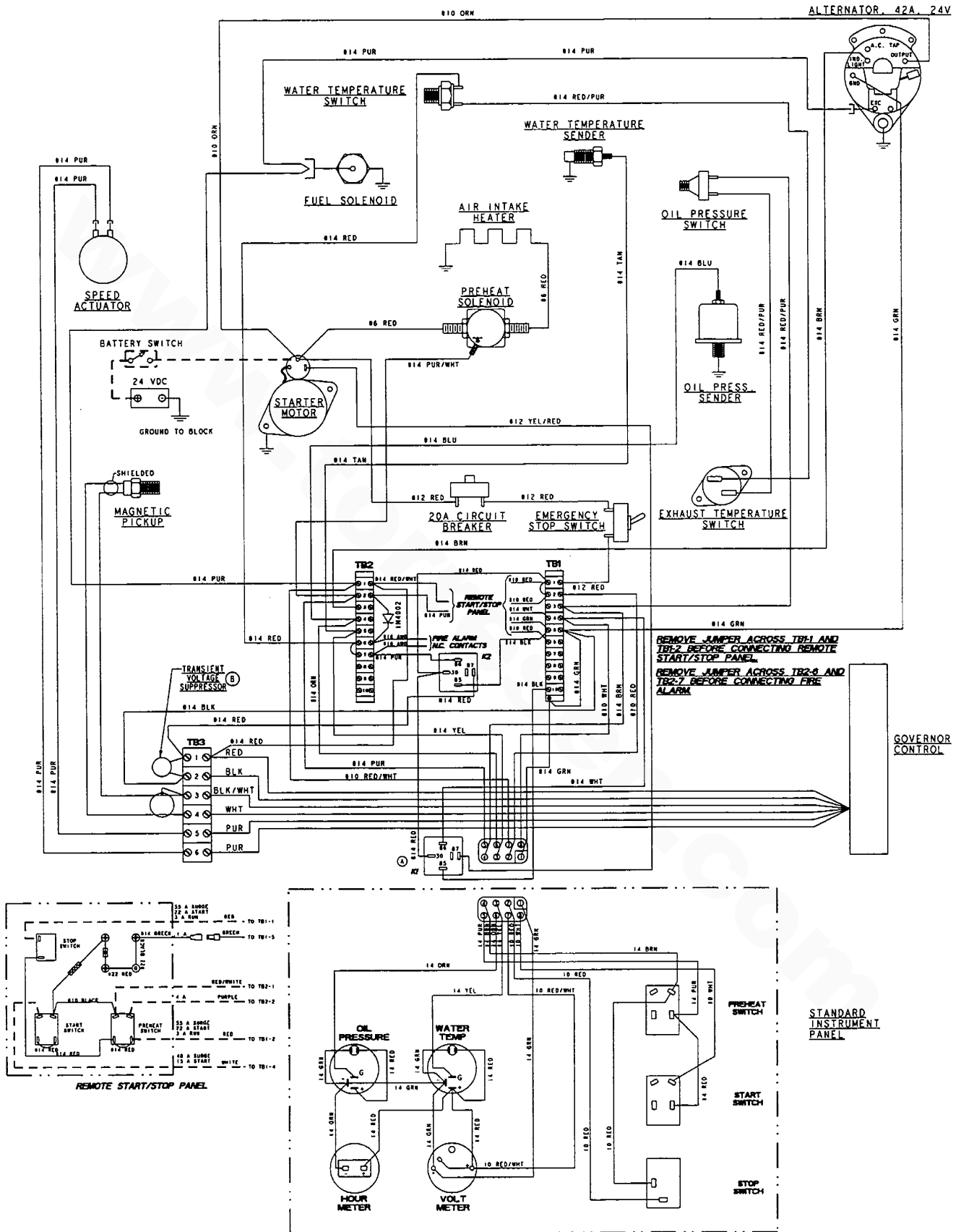

32 KW BEDA GENERATOR

WIRING SCHEMATIC #041128 (SINGLE RELAY)
24 VDC SPECIAL SPEC.

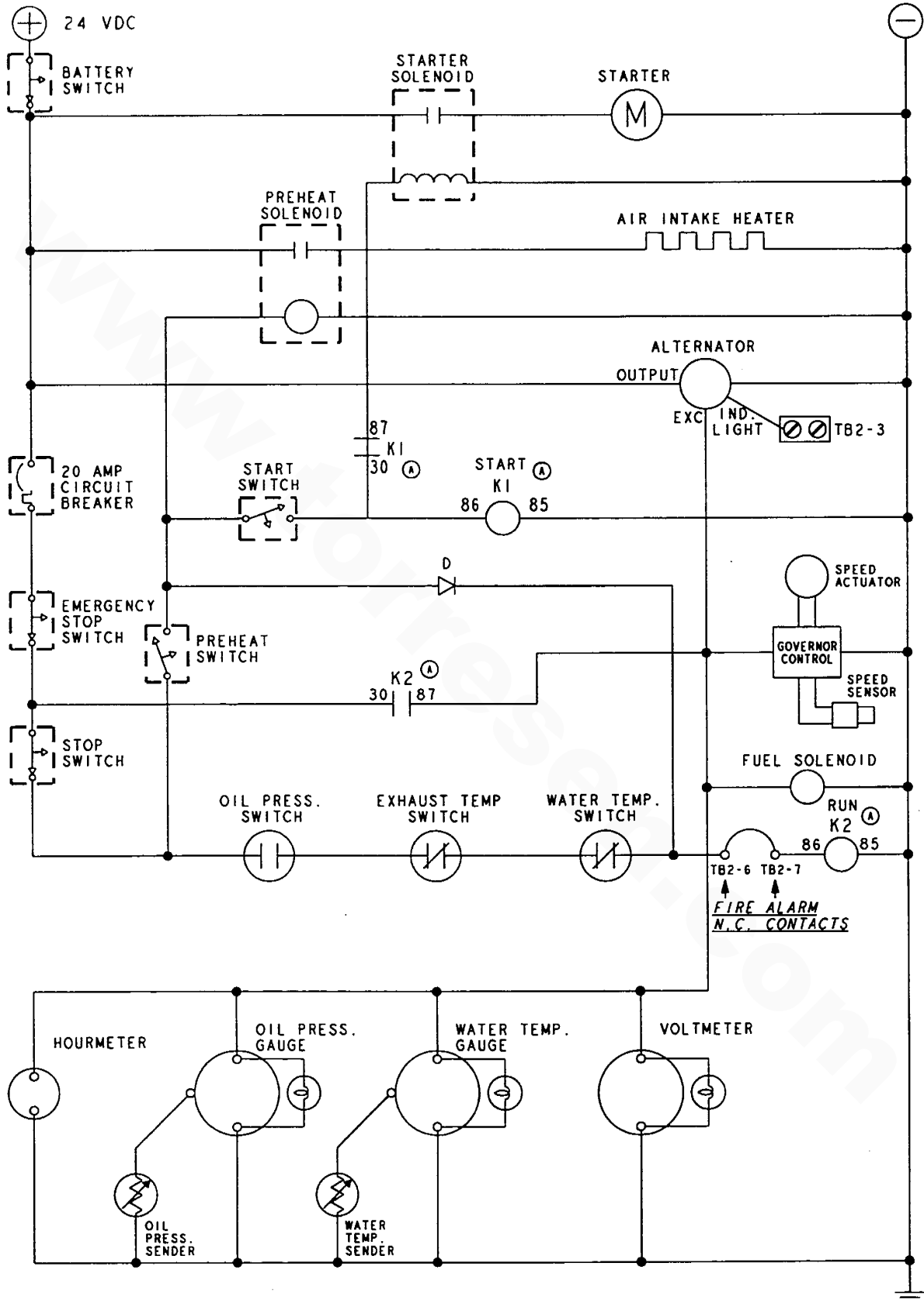

32 KW BEDA GENERATOR

WIRING DIAGRAM #44806 (TWO RELAYS) (PLUG-IN REMOTE START/STOP PANEL)

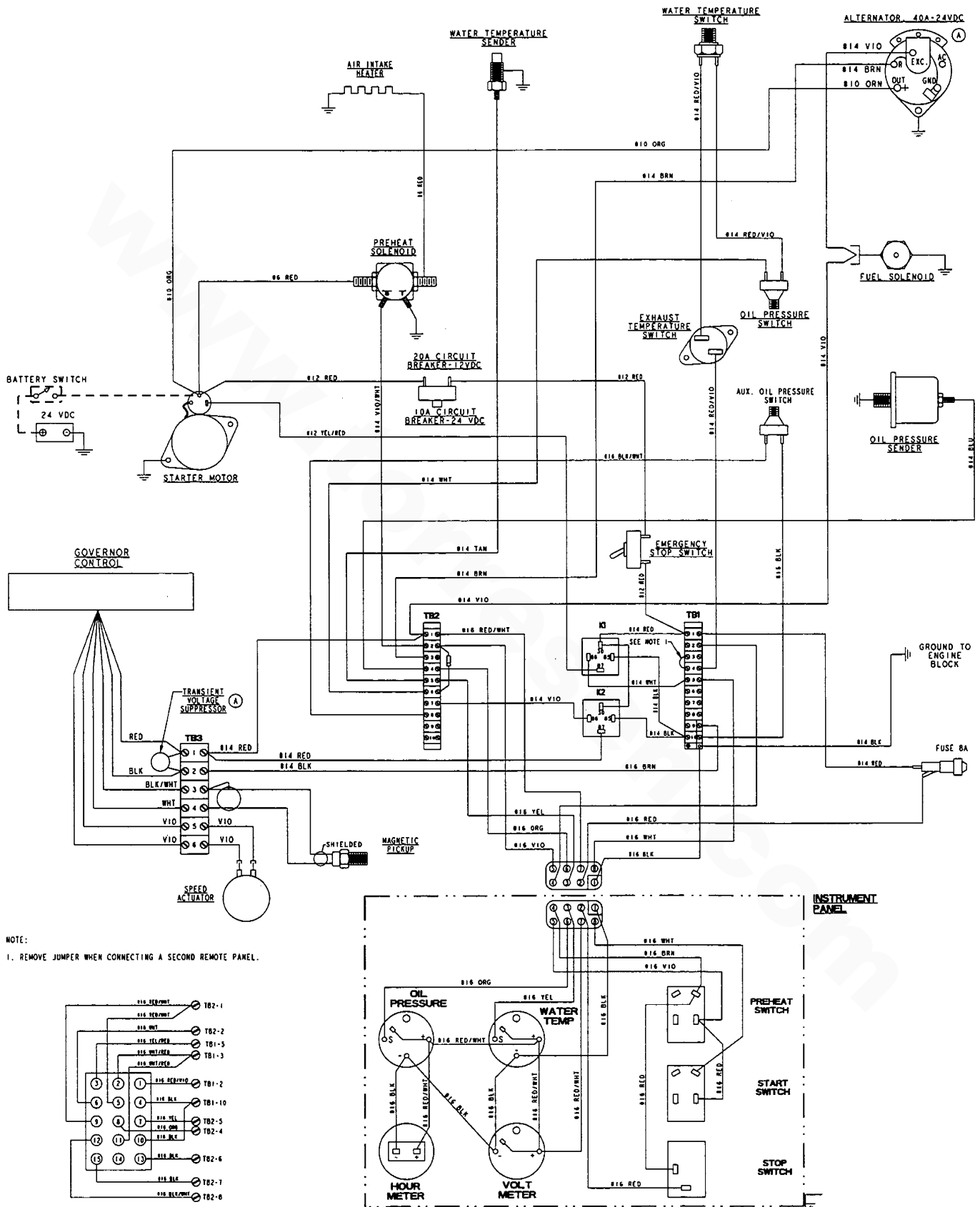

NOTE:
1. REMOVE JUMPER WHEN CONNECTING A SECOND REMOTE PANEL.

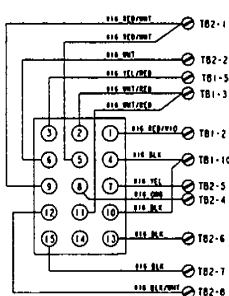

32 KW BEDA GENERATOR

WIRING SCHEMATIC #44806 (TWO RELAYS) (PLUG-IN REMOTE START/STOP PANEL)

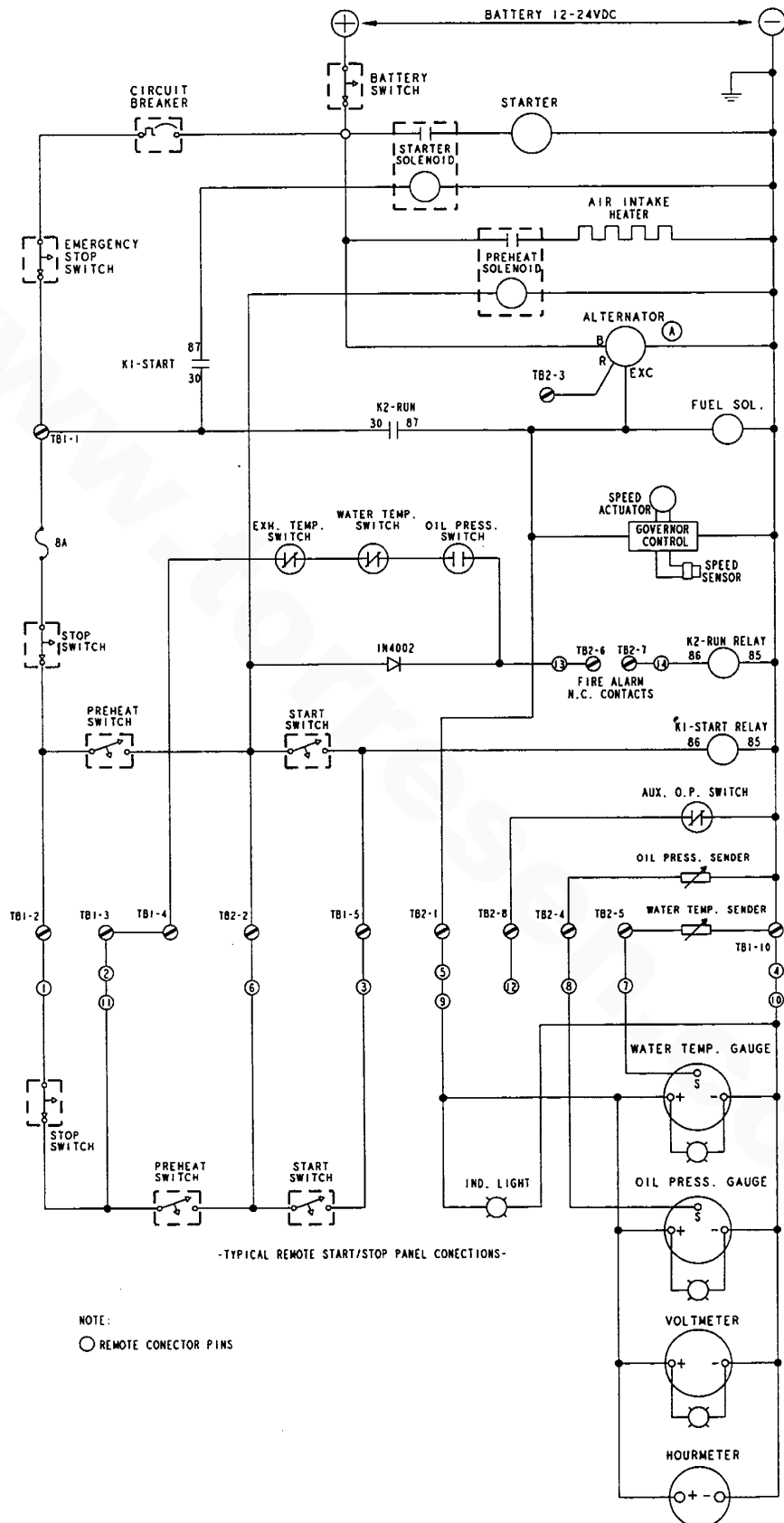

-TYPICAL REMOTE START/STOP PANEL CONNECTIONS-

NOTE:
○ REMOTE CONNECTOR PINS



SPECIAL TOOLS – GENERATOR

FIELD FABRICATED TOOLS

These drawings provide a means by which simple tools can be made to assist in the removal of the generator end from the engine, and in the replacement of the generator end on the engine. A local machine shop should be able to fabricate these tools at a modest price, but first check with your local WEST-ERBEKE dealer to see if these tools are available on loan.

Ø.28 (6 HOLES)

Lifting Eye Tool

This tool allows a mechanic to safely remove the generator end from the engine. Attach this Generator End Lifting Eye to the four screw holes located under the control panel. To use this Lifting Eye, remove the generator's control panel and screw the Lifting Eye to the generator end using four M6 x 1.0 pitch capscrews.

MATERIAL: 3/16" STEEL
DIMENSIONS ARE IN INCHES

Back End Lifting Eye Tool

This Lifting Eye mounts to the back end of the generator. Attach this Lifting Eye with two M12 x 1.75 pitch capscrews using the two holes that are adjacent to the rear carrier bearing housing.

MATERIAL: STEEL
DIMENSIONS ARE IN INCHES

SPECIAL TOOLS – GENERATOR

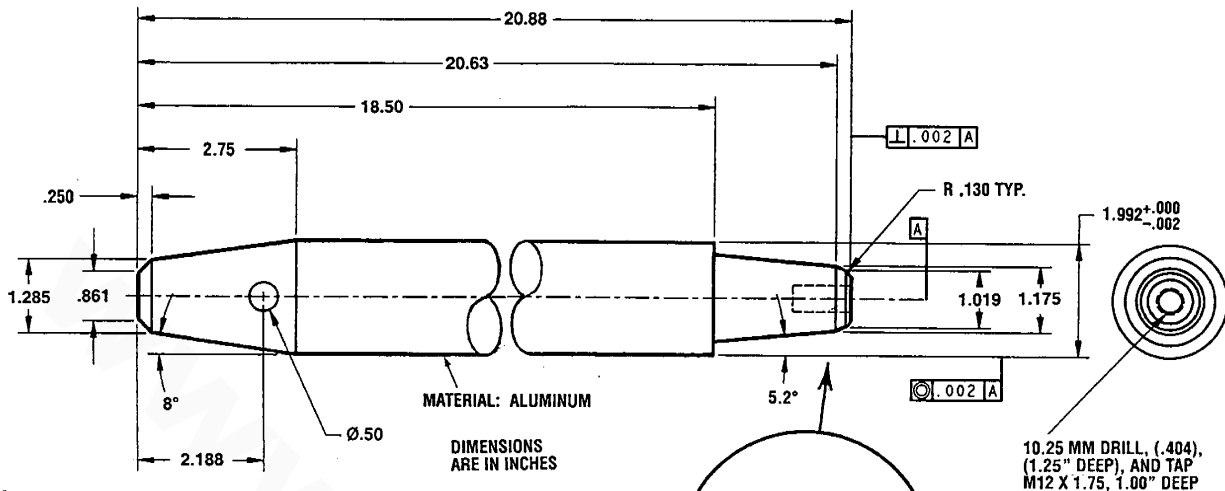

Pilot Tool

This tool prevents the rotor from damaging the windings when the generator housing is removed from the engine or when it is installed on the engine. Screw the M12 threaded rod into the end of the Pilot Tool, then screw the Pilot Tool into the rotor shaft to use as a guide.

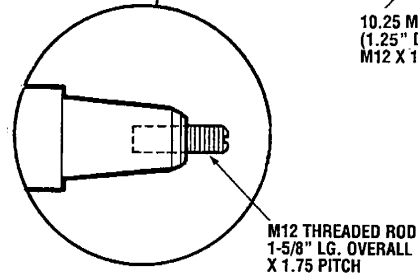

Disk Alignment Tool

This tool allows a mechanic to safely remove and install the generator drive disks by aligning the disks with the Drive Plate Guide Pin. The Pin screws into the flywheel and acts as a guide. Also the pin helps to support some of the rotor and the drive plate's weight while removing or replacing these parts.

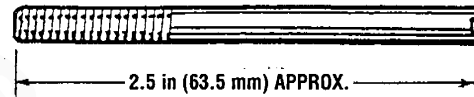

Material: One M10 x .125 pitch bolt with the hex head machined off and a screwdriver slot cut in the machined end.

INDEX

AC Voltage Connections.....	107, 108	Fuel System (<i>continued</i>)	
Air Intake Heater.....	81	Feed Pump Strainer.....	60
Air Intake Silencer.....	42	Filter.....	42, 45, 59
Alternator.....	44, 82	Injection Pump.....	63
Alternator Bracket.....	40	Injectors.....	42, 61
Alternator – Dual Output.....	84	Lift Pump.....	59
Back Plate.....	19, 36, 45	Return Lines.....	42
Battery.....	81, 83	Flywheel.....	15, 29, 36
BE Generator, Single and Three Phase.....	106	Frequency Adjustment – Generator.....	103
BE Generator Troubleshooting.....	112	Generator	
Bellhousing.....	15, 45	AC Voltage Connections.....	107, 108
Camshaft.....	19, 23, 32	BE, Single and Three Phase.....	106
Circuit Breaker.....	106	Circuit Breaker.....	106
Compression Test.....	6, 49	Control Panel Switches.....	104
Connecting Rod.....	19, 27, 34	Frequency Adjustment.....	103
Control Panel – Admiral.....	78	Information.....	103
Control Panel – Captain.....	79	Internal Wiring Schematics.....	110, 111
Control Panel Switches – Generator.....	104	Maintenance.....	103
Control Panel Troubleshooting – Engine.....	80	Mounting.....	46
Control Panel Troubleshooting – Generator.....	105	Removal.....	14
Coolant.....	45, 46	Special Tools.....	126
Coolant Pump.....	40, 54, 55	Specifications.....	100
Coolant Pump Connector and Hose.....	44	Troubleshooting.....	112
Crankcase Breather Hose.....	45	Heat Exchanger.....	45, 54, 55
Crankshaft.....	19, 28, 32	Hourmeter.....	80
Crankshaft Pulley.....	40	Idle Speed Adjustment.....	49, 50
Cylinder Block.....	29	Injection Pump.....	63
Cylinder Head.....	16, 20, 40	Intake Manifold.....	42
Cylinder Head Bolts.....	16, 41, 49	Lifting Eyes.....	42
Cylinder Liner.....	19, 26, 33	Lower Block.....	18, 37
Drive Belt Adjustment.....	48	Main Bearing.....	19, 32
Electronic Governor.....	113	Metric Conversions.....	130, 131
Electronic Governor Troubleshooting.....	114	Oil	
Engine		Cooler.....	38
Adjustments.....	48	Filter Housing.....	18, 38
Disassembly.....	14	Jet.....	30, 31
Inspection and Repair.....	20	Level Dipstick.....	43
Overhaul.....	6	Pressure.....	51
Parts Identification.....	5	Pressure Gauges.....	105
Reassembly.....	31	Pressure Sender.....	18, 45, 51
Specifications.....	4	Pressure Switch.....	18, 45, 51
Troubleshooting.....	7	Pump.....	18, 38, 51
Exhaust Manifold.....	45, 46, 47	Sump.....	18, 38
Fuel System		Parts Identification – Engine.....	5
Bleeding.....	60	Parts Identification – Generator.....	102
Feed Line.....	43	Piston and Piston Rings.....	19, 25, 34

(continued)



INDEX

Pumps		Valve	
Coolant.....	40, 54, 55	Valves.....	17, 20, 21, 31
Fuel Lift.....	59	Clearance Adjustment.....	48
Injection.....	63	Guide.....	21
Raw Water.....	44, 54, 58	Seal.....	31
Push Rod.....	24, 40	Seat.....	20
Raw Water Pump.....	44, 54, 58	Spring.....	22
Rear Oil Seal – Crankshaft.....	19, 29, 36	Stem Caps.....	41
Remote Panel.....	104	Voltage Regulator Adjustment.....	109
Rocker Arm and Shaft.....	16, 24, 41	Water Temperature Gauge.....	105
Rocker Cover.....	16, 45	Wiring Diagrams/Schematics	
Sealants and Lubricants.....	98	90A Four Propulsion Engine	
Shore Power Transfer Switch.....	115	Wiring Diagram #41343.....	86
Special Tools – Generator.....	126	90A Four Propulsion Engine	
Specifications		Wiring Schematic #41343.....	87
Engine.....	4	32 KW BEDA Generator Wiring Diagram #040425	
Generator.....	100	(Single Relay).....	116
Lubrication.....	53	32 KW BEDA Generator Wiring Schematic #040425	
Standard Hardware.....	98	(Single Relay).....	117
Starter Motor.....	45, 64	32 KW BEDA Generator Wiring Diagram #040425	
Tachometer.....	49, 80	(Two Relays).....	118
Tappets.....	23, 32	32 KW BEDA Generator Wiring Schematic #040425	
Testing for Overhaul.....	6	(Two Relays).....	119
Thermostat.....	16, 44, 54, 55	32 KW BEDA Generator Wiring Diagram #44737	
Timing Gear Case.....	17, 37	(Two Relays)(Plug-in Remote Start/Stop Panel)..	120
Timing Gear Cover.....	17, 39	32 KW BEDA Generator Wiring Schematic #44737	
Timing Gears.....	17, 30, 38	(Two Relays)(Plug-in Remote Start/Stop Panel)..	121
Torques		32 KW BEDA Generator Wiring Diagram #041128	
90A Four Engine.....	99	(Single Relay) 24 VDC Special Spec.....	122
Standard Hardware.....	98	32 KW BEDA Generator Wiring Schematic #041128	
Transmission		(Single Relay) 24 VDC Special Spec.....	123
Borg Warner Velvet Drive.....	93	32 KW BEDA Generator Wiring Diagram #44806	
Damper Plate.....	15, 45	(Two Relays) (Plug-in Remote Start/Stop Panel)..	124
Hurth HBW 250.....	91	32 KW BEDA Generator Wiring Schematic #44806	
Hurth HSW.....	88	(Two Relays) (Plug-in Remote Start/Stop Panel)..	125
Oil Coolers.....	45, 88, 96	Wiring Harness.....	45
Removal.....	14		
Troubleshooting.....	96		
Troubleshooting			
BE Generator.....	112		
Electronic Governor.....	114		
Engine.....	7		
Engine Control Panel.....	80		
Generator Control Panel.....	105		
Transmission.....	96		

METRIC CONVERSIONS

INCHES TO MILLIMETERS				MILLIMETERS TO INCHES			
Inches	mm	Inches	mm	mm	Inches	mm	Inches
1	25.40	15	381.00	1	0.0394	15	0.5906
2	50.80	20	508.00	2	0.0787	20	0.7874
3	76.20	25	635.00	3	0.1181	25	0.9843
4	101.60	30	762.00	4	0.1575	30	1.1811
5	127.00	35	889.00	5	0.1969	35	1.3780
10	254.00	40	1016.00	10	0.3937	40	1.5748

10 MILLIMETERS = 1 CENTIMETER, 100 CENTIMETERS = 1 METER = 39.37 INCHES (3.3 FEET)

INCHES TO METERS				METERS TO INCHES			
Inches	Meters	Inches	Meters	Meters	Inches	Meters	Inches
1	0.0254	7	0.1778	0.1	3.937	0.7	27.559
2	0.0508	8	0.2032	0.2	7.874	0.8	31.496
3	0.0762	9	0.2286	0.3	11.811	0.9	35.433
4	0.1016	10	0.2540	0.4	15.748	1.0	39.370
5	0.1270	11	0.2794	0.5	19.685	1.1	43.307
6	0.1524	12	0.3048	0.6	23.622	1.2	47.244

TO CONVERT METERS TO CENTIMETERS, MOVE DECIMAL POINT TWO PLACES TO THE RIGHT

YARDS TO METERS				METERS TO YARDS			
Yards	Meters	Yards	Meters	Meters	Yards	Meters	Yards
1	0.91440	6	5.48640	1	1.09361	6	6.56168
2	1.82880	7	6.40080	2	2.18723	7	7.65529
3	2.74320	8	7.31520	3	3.28084	8	8.74891
4	3.65760	9	8.22960	4	4.37445	9	9.84252
5	4.57200	10	9.14400	5	5.46807	10	10.93614

MOVE DECIMAL POINT FOR HIGHER VALUES — e.g. 6,000 METERS = 6,561.68 YARDS

POUNDS TO KILOGRAMS				KILOGRAMS TO POUNDS			
lb	kg	lb	kg	kg	lb	kg	lb
1	0.454	6	2.722	1	2.205	6	13.228
2	0.907	7	3.175	2	4.409	7	15.432
3	1.361	8	3.629	3	6.614	8	17.637
4	1.814	9	4.082	4	8.818	9	19.842
5	2.268	10	4.536	5	11.023	10	22.046

GALLONS TO LITERS				LITERS TO GALLONS			
Gallons	Liters	Gallons	Liters	Liters	Gallons	Liters	Gallons
1	3.79	10	37.86	1	0.26	60	15.66
2	7.57	20	75.71	2	0.53	90	23.77
3	11.36	30	113.57	5	1.32	120	31.32
4	15.14	40	151.42	10	2.64	150	39.62
5	18.93	50	189.28	20	5.28	180	47.54

PINTS TO LITERS				LITERS TO PINTS			
Pints	Liters	Pints	Liters	Liters	Pints	Liters	Pints
1	0.47	6	2.84	1	2.11	6	12.68
2	0.95	7	3.31	2	4.23	7	14.79
3	1.42	8	3.79	3	6.34	8	16.91
4	1.89	9	4.26	4	8.45	9	19.02
5	2.37	10	4.73	5	10.57	10	21.13

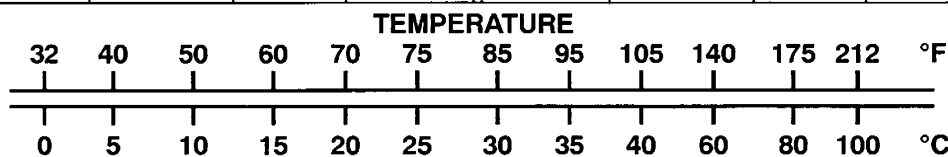

STANDARD AND METRIC CONVERSION DATA

LENGTH-DISTANCE

Inches (in) x 25.4 = Millimeters (mm) x .0394 = Inches
Feet (ft) x .305 = Meters (m) x 3.281 = Feet
Miles x 1.609 = Kilometers (km) x .0621 = Miles

VOLUME

Cubic Inches (in³) x 16.387 = Cubic Centimeters x .061 = in³
Imperial Pints (IMP pt) x .568 = Liters (L) x 1.76 = IMP pt
Imperial Quarts (IMP qt) x 1.137 = Liters (L) x .88 = IMP qt
Imperial Gallons (IMP gal) x 4.546 = Liters (L) x .22 = IMP gal
Imperial Quarts (IMP qt) x 1.201 = US Quarts (US qt) x .833 = IMP qt
Imperial Gallons (IMP gal) x 1.201 = US Gallons (US gal) x .833 = IMP gal
Fluid Ounces x 29.573 = Milliliters x .034 = Ounces
US Pints (US pt) x .473 = Liters(L) x 2.113 = Pints
US Quarts (US qt) x .946 = Liters (L) x 1.057 = Quarts
US Gallons (US gal) x 3.785 = Liters (L) x .264 = Gallons

MASS-WEIGHT

Ounces (oz) x 28.35 = Grams (g) x .035 = Ounces
Pounds (lb) x .454 = Kilograms (kg) x 2.205 = Pounds

PRESSURE

Pounds Per Sq In (psi) x 6.895 = Kilopascals (kPa) x .145 = psi
Inches of Mercury (Hg) x .4912 = psi x 2.036 = Hg
Inches of Mercury (Hg) x 3.377 = Kilopascals (kPa) x .2961 = Hg
Inches of Water (H₂O) x .07355 = Inches of Mercury x 13.783 = H₂O
Inches of Water (H₂O) x .03613 = psi x 27.684 = H₂O
Inches of Water (H₂O) x .248 = Kilopascals (kPa) x 4.026 = H₂O

TORQUE

Pounds-Force Inches (in-lb) x .113 = Newton Meters (Nm) x 8.85 = in-lb
Pounds-Force Feet (ft-lb) x 1.356 = Newton Meters (Nm) x .738 = ft-lb

VELOCITY

Miles Per Hour (MPH) x 1.609 = Kilometers Per Hour (KPH) x .621 = MPH

POWER

Horsepower (Hp) x .745 = Kilowatts (Kw) x 1.34 = MPH

FUEL CONSUMPTION

Miles Per Hour IMP (MPG) x .354 = Kilometers Per Liter (Km/L)
Kilometers Per Liter (Km/L) x 2.352 = IMP MPG
Miles Per Gallons US (MPG) x .425 = Kilometers Per Liter (Km/L)
Kilometers Per Liter (Km/L) x 2.352 = US MPG

TEMPERATURE

Degree Fahrenheit (°F) = (°C X 1.8) + 32
Degree Celsius (°C) = (°F - 32) x .56



www.torresen.com

www.torresen.com

