



OPERATORS MANUAL

FOR THE

4.5KW BCGB - 60HZ

3.8KW BCGB - 50Hz

AND

7.0KW BCGB - 60HZ

5.0KW BCGB - 50Hz

**GASOLINE GENERATORS
SINGLE PHASE**

PUBLICATION NO.44200
JUNE 1999
1ST EDITION

 **WESTERBEKE**

WESTERBEKE CORPORATION
MYLES STANDISH INDUSTRIAL PARK
150 JOHN HANCOCK ROAD, TAUNTON, MA 02780-7319

 *Member National Marine Manufacturers Association*

 **WARNING:**

Exhaust gasses contain Carbon Monoxide, an odorless and colorless gas. Carbon Monoxide is poisonous and can cause unconsciousness and death. Symptoms of Carbon Monoxide exposure can include:

- *Dizziness*
- *Nausea*
- *Headache*
- *Weakness and Sleepiness*
- *Throbbing in Temples*
- *Muscular Twitching*
- *Vomiting*
- *Inability to Think Coherently*

IF YOU OR ANYONE ELSE EXPERIENCE ANY OF THESE SYMPTOMS, GET OUT INTO THE FRESH AIR IMMEDIATELY. If symptoms persist, seek medical attention. Shut down the unit and do not restart until it has been inspected and repaired.





Declaration of Conformity

Application of Council Directive(s) EMC 89/336/EEC
ISO 8846 1990(E)

Standard(s) to Which Conformity is declared EN50081-1
EN50082-2
EN55020
ISO-8846-1990(E), Certification Number, IWES003

Manufacturers Name Westerbeke Corporation

Manufacturers Address 150 John Hancock Road
Myles Standish Industrial Park
Taunton, Ma. 02780-7319, USA

Type of Equipment Marine Gasoline Generator

Product Name Westerbeke Marine Gasoline Generator

Model(s) 3.5BCGB-514, 4.5BCGB-614
5.0BCGB-514, 7.0BCGB-614

Product Options All

Supplementary Information

- 1.) The equipment listed is only for use in Marine Applications aboard boats.
- 2.) The equipment listed must be located below decks on the vessel and permanently installed in it's location.
- 3.) The equipment listed must be wired to the grounding system of the vessel.

I the undersigned, hereby declare that the equipment specified above conforms to the above Directive(s) and Standard(s).

Place Taunton, Massachusetts, U.S.A.

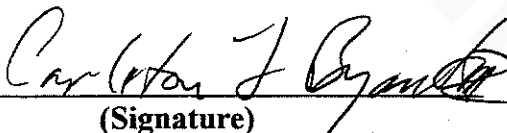
(Signature)

Date: January 1, 2001

Carleton F. Bryant
(Full Name)

Chief Operating Officer
(Title)

042022

INTERNATIONAL MARINE CERTIFICATION INSTITUTE

Rond Point Schuman 6, Box 6
 B - 1040 BRUXELLES
 BELGIQUE
 tel: (32) 2-236-7882
 fax: (32) 2-236-7700



CERTIFICATE

We hereby certify the component stated below meets the EC Directive 94/25/EC for EC type-examination in accordance with ISO 8846 and has following characteristics:

TYPE	Gasoline Marine Generator
MANUFACTURER	Westerbeke Corp.
ADDRESS	Avon Industrial Park, AVON, MA 02333 USA

GROUP OF	*	+++++	+++++
Model 1	3.5/4.5 BCGB	+++++	+++++
Model 2	5.0/7.0 BCGB	+++++	+++++
Model 3	+++++	+++++	+++++
Model 4	+++++	+++++	+++++
Model 5	+++++	+++++	+++++
Model 6	+++++	+++++	+++++
Model 7	+++++	+++++	+++++
Model 8	+++++	+++++	+++++
Model 9	+++++	+++++	+++++
Model 10	+++++	+++++	+++++
Model 11	+++++	+++++	+++++
Model 12	+++++	+++++	+++++
Model 13	+++++	+++++	+++++
Model 14	+++++	+++++	+++++
Model 15	+++++	+++++	+++++
Model 16	+++++	+++++	+++++
Model 17	+++++	+++++	+++++
Model 18	+++++	+++++	+++++
Model 19	+++++	+++++	+++++
Model 20	+++++	+++++	+++++
Model 21	+++++	+++++	+++++
Model 22	+++++	+++++	+++++
Model 23	+++++	+++++	+++++

Certification number	IGPWESTER004
Signed	<i>Lars E. Granholm</i>
Name	Lars E. Granholm
Title	Managing Director
EU Notified Body No.	0609
Date	27-Jun-99

SAFETY INSTRUCTIONS

INTRODUCTION

Read this safety manual carefully. Most accidents are caused by failure to follow fundamental rules and precautions. Know when dangerous conditions exist and take the necessary precautions to protect yourself, your personnel, and your machinery.

The following safety instructions are in compliance with the American Boat and Yacht Council (ABYC) standards.

PREVENT ELECTRIC SHOCK

⚠ WARNING: Do not touch AC electrical connections while engine is running, or when connected to shore power. Lethal voltage is present at these connections!

- Do not operate this machinery without electrical enclosures and covers in place.
- Shut off electrical power before accessing electrical equipment.
- Use insulated mats whenever working on electrical equipment.
- Make sure your clothing and skin are dry, not damp (particularly shoes) when handling electrical equipment.
- Remove wristwatch and all jewelry when working on electrical equipment.
- Do not connect utility shore power to vessel's AC circuits, except through a ship-to-shore double throw transfer switch. Damage to vessel's AC generator may result if this procedure is not followed.
- Electrical shock results from handling a charged capacitor. Discharge capacitor by shorting terminals together.

PREVENT BURNS — HOT ENGINE

⚠ WARNING: Do not touch hot engine parts or exhaust system components. A running engine gets very hot!

- Always check the engine coolant level at the coolant recovery tank.

⚠ WARNING: Steam can cause injury or death!

- In case of an engine overheat, allow the engine to cool before touching the engine or checking the coolant.

PREVENT BURNS — FIRE

⚠ WARNING: Fire can cause injury or death!

- Prevent flash fires. Do not smoke or permit flames or sparks to occur near the carburetor, fuel line, filter, fuel pump, or other potential sources of spilled fuel or fuel vapors. Use a suitable container to catch all fuel when removing the fuel line, carburetor, or fuel filters.
- Do not operate with a Coast Guard Approved flame arrester removed. Backfire can cause severe injury or death.
- Do not operate with the air cleaner/silencer removed. Backfire can cause severe injury or death.
- Do not smoke or permit flames or sparks to occur near the fuel system. Keep the compartment and the engine/generator clean and free of debris to minimize the chances of fire. Wipe up all spilled fuel and engine oil.
- Be aware — diesel fuel will burn.

PREVENT BURNS — EXPLOSION

⚠ WARNING: Explosions from fuel vapors can cause injury or death!

- Follow re-fueling safety instructions. Keep the vessel's hatches closed when fueling. Open and ventilate cabin after fueling. Check below for fumes/vapor before running the blower. Run the blower for four minutes before starting your engine.
- All fuel vapors are highly explosive. Use extreme care when handling and storing fuels. Store fuel in a well-ventilated area away from spark-producing equipment and out of the reach of children.
- Do not fill the fuel tank(s) while the engine is running.
- Shut off the fuel service valve at the engine when servicing the fuel system. Take care in catching any fuel that might spill. DO NOT allow any smoking, open flames, or other sources of fire near the fuel system or engine when servicing. Ensure proper ventilation exists when servicing the fuel system.
- Do not alter or modify the fuel system.
- Be sure all fuel supplies have a positive shutoff valve.
- Be certain fuel line fittings are adequately tightened and free of leaks.
- Make sure a fire extinguisher is installed nearby and is properly maintained. Be familiar with its proper use. Extinguishers rated ABC by the NFPA are appropriate for all applications encountered in this environment.

www.torresen.com

SAFETY INSTRUCTIONS

ACCIDENTAL STARTING

⚠ WARNING: Accidental starting can cause injury or death!

- Disconnect the battery cables before servicing the engine/generator. Remove the negative lead first and reconnect it last.
- Make certain all personnel are clear of the engine before starting.
- Make certain all covers, guards, and hatches are re-installed before starting the engine.

BATTERY EXPLOSION

⚠ WARNING: Battery explosion can cause injury or death!

- Do not smoke or allow an open flame near the battery being serviced. Lead acid batteries emit hydrogen, a highly explosive gas, which can be ignited by electrical arcing or by lit tobacco products. Shut off all electrical equipment in the vicinity to prevent electrical arcing during servicing.
- Never connect the negative (-) battery cable to the positive (+) connection terminal of the starter solenoid. Do not test the battery condition by shorting the terminals together. Sparks could ignite battery gases or fuel vapors. Ventilate any compartment containing batteries to prevent accumulation of explosive gases. To avoid sparks, do not disturb the battery charger connections while the battery is being charged.
- Avoid contacting the terminals with tools, etc., to prevent burns or sparks that could cause an explosion. Remove wristwatch, rings, and any other jewelry before handling the battery.
- Always turn the battery charger off before disconnecting the battery connections. Remove the negative lead first and reconnect it last when disconnecting the battery.

BATTERY ACID

⚠ WARNING: Sulfuric acid in batteries can cause severe injury or death!

- When servicing the battery or checking the electrolyte level, wear rubber gloves, a rubber apron, and eye protection. Batteries contain sulfuric acid which is destructive. If it comes in contact with your skin, wash it off at once with water. Acid may splash on the skin or into the eyes inadvertently when removing electrolyte caps.

TOXIC EXHAUST GASES

⚠ WARNING: Carbon monoxide (CO) is a deadly gas!

- Ensure that the exhaust system is adequate to expel gases discharged from the engine. Check the exhaust system regularly for leaks and make sure the exhaust manifolds are securely attached and no warping exists. Pay close attention to the manifold, water injection elbow, and exhaust pipe nipple.
- Be sure the unit and its surroundings are well ventilated.
- In addition to routine inspection of the exhaust system, install a carbon monoxide detector. Consult your boat builder or dealer for installation of approved detectors.
- For additional information refer to ABYC T-22 (educational information on Carbon Monoxide).

⚠ WARNING: Carbon monoxide (CO) is an invisible odorless gas. Inhalation produces flu-like symptoms, nausea or death!

- Do not use copper tubing in diesel exhaust systems. Diesel fumes can rapidly destroy copper tubing in exhaust systems. Exhaust sulfur causes rapid deterioration of copper tubing resulting in exhaust/water leakage.
- Do not install exhaust outlet where exhaust can be drawn through portholes, vents, or air conditioners. If the engine exhaust discharge outlet is near the waterline, water could enter the exhaust discharge outlet and close or restrict the flow of exhaust. Avoid overloading the craft.
- Although diesel engine exhaust gases are not as toxic as exhaust fumes from gasoline engines, carbon monoxide gas is present in diesel exhaust fumes. Some of the symptoms or signs of carbon monoxide inhalation or poisoning are:
 - Vomiting
 - Dizziness
 - Throbbing in temples
 - Muscular twitching
 - Intense headache
 - Weakness and sleepiness

AVOID MOVING PARTS

⚠ WARNING: Rotating parts can cause injury or death!

- Do not service the engine while it is running. If a situation arises in which it is absolutely necessary to make operating adjustments, use extreme care to avoid touching moving parts and hot exhaust system components.

www.torresen.com

SAFETY INSTRUCTIONS

- Do not wear loose clothing or jewelry when servicing equipment; tie back long hair and avoid wearing loose jackets, shirts, sleeves, rings, necklaces or bracelets that could be caught in moving parts.
- Make sure all attaching hardware is properly tightened. Keep protective shields and guards in their respective places at all times.
- Do not check fluid levels or the drive belt's tension while the engine is operating.
- Stay clear of the drive shaft and the transmission coupling when the engine is running; hair and clothing can easily be caught in these rotating parts.

HAZARDOUS NOISE

▲ WARNING: High noise levels can cause hearing loss!

- Never operate an engine without its muffler installed.
- Do not run an engine with the air intake (silencer) removed.
- Do not run engines for long periods with their enclosures open.

▲ WARNING: Do not work on machinery when you are mentally or physically incapacitated by fatigue!

OPERATORS MANUAL

Many of the preceding safety tips and warnings are repeated in your Operators Manual along with other cautions and notes to highlight critical information. Read your manual carefully, maintain your equipment, and follow all safety procedures.

GASOLINE ENGINE AND GENERATOR INSTALLATIONS

Preparations to install a gasoline engine or generator should begin with a thorough examination of the American Boat and Yacht Council's (ABYC) standards. These standards are from a combination of sources including the USCG and the NFPA.

Sections of the ABYC standards of particular interest are:

- H-2 Ventilation
- H-24 Gasoline fuel systems
- P-1 Exhaust systems
- P-4 Inboard engines
- E-9 DC Electrical systems

All installations must comply with the Federal Code of Regulations (FCR).

ABYC, NFPA AND USCG PUBLICATIONS FOR INSTALLING DIESEL ENGINES

Read the following ABYC, NFPA and USCG publications for safety codes and standards. Follow their recommendations when installing your engine.

ABYC (American Boat and Yacht Council)
"Safety Standards for Small Craft"

Order from:

ABYC
15 East 26th Street
New York, NY 10010

NFPA (National Fire Protection Association)
"Fire Protection Standard for Motor Craft"

Order from:

National Fire Protection Association
11 Tracy Drive
Avon Industrial Park
Avon, MA 02322

USCG (United States Coast Guard)
"USCG 33CFR183"

Order from:

U.S. Government Printing Office
Washington, D.C. 20404

www.torresen.com

INSTALLATION

When installing WESTERBEKE engines and generators it is important that strict attention be paid to the following information:

CODES AND REGULATIONS

Strict federal regulations, ABYC guidelines, and safety codes must be complied with when installing engines and generators in a marine environment.

SIPHON-BREAK

For installations where the exhaust manifold/water injected exhaust elbow is close to or will be below the vessel's waterline, provisions must be made to install a siphon-break in the raw water supply hose to the exhaust elbow. This hose must be looped a minimum of 20" above the vessel's waterline. *Failure to use a siphon-break when the exhaust manifold injection port is at or below the load waterline will result in raw water damage to the engine and possible flooding of the boat.*

If you have any doubt about the position of the water-injected exhaust elbow relative to the vessel's waterline under the vessel's various operating conditions, *install a siphon-break.*

NOTE: *A siphon-break requires periodic inspection and cleaning to ensure proper operation. Failure to properly maintain a siphon-break can result in catastrophic engine damage. Consult the siphon-break manufacturer for proper maintenance.*

EXHAUST SYSTEM

The exhaust hose must be certified for marine use. The system must be designed to prevent water from entering the exhaust under any sea conditions and at any angle of the vessels hull.

A detailed 40 page Marine Installation Manual covering gasoline and diesel, engines and generators, is available from your WESTERBEKE dealer.



www.torresen.com

TABLE OF CONTENTS

Parts Identification	2	Engine Adjustments	26
Introduction	3	Speed Hertz Adjustment.....	26
Serial Number Location.....	3	Torquing the Cylinder Head Bolts.....	26
Fuel, Engine Oil and Engine Coolant	5	Spark Plugs.....	27
Control Panels	6	Drive Belt Adjustment.....	27
Preparations for Initial Start-Up	7	Valve Clearance.....	28
Operating Instructions	8	Choke Solenoid.....	28
Remote Panel.....	9	Timing Belt.....	29
Break-In Procedure/Daily Operation	10	Engine Compression.....	32
Safety Shutdown Switches	11	Component Testing	33
Maintenance Schedule	12	Engine Troubleshooting	34
Cooling System	14	Generator Information	36
Changing Coolant.....	15	BC Generator Single Phase	37
Thermostat.....	16	AC Terminal Board Connections	40
Heat Exchanger.....	16	Battery Circuit/Resistance Values	40
Raw Water Intake Strainer.....	17	BC Generator Single Phase	41
Raw Water Pump.....	17	Testing Component Resistance.....	42
Fuel System	18	Integral Controller.....	43
Carburetor.....	18	Testing the Battery Charger.....	43
Fuel Lift Pump.....	18	Battery Charging Circuit	44
Gasdenser.....	18	Testing the Battery Charging Circuit	45
Gasoline/Water Seperator.....	18	Shore Power Transfer Switch	46
Carburetor Adjustments	19	Lay-up and Recommissioning	47
Engine Lubricating Oil	20	Generator Specifications	49
Oil Pressure	21	Standard Hardware	50
Remote Oil Filter	22	BCGB Hardware Torques	51
BCGB Wiring Diagram	23	Metric Conversions Chart	52
BCGB Wiring Schematic	24	Suggested Spare Parts	53
Remote Panel Wiring	25		

BCGB PARTS IDENTIFICATION

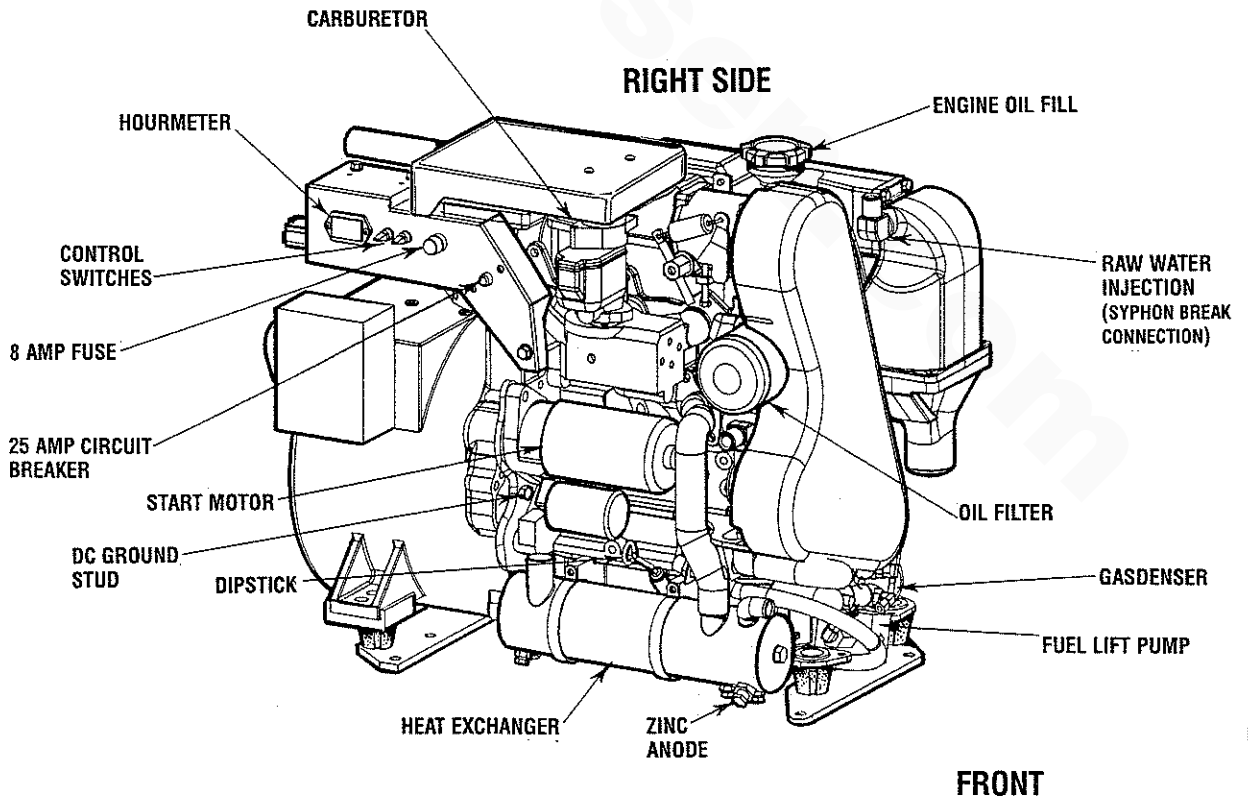
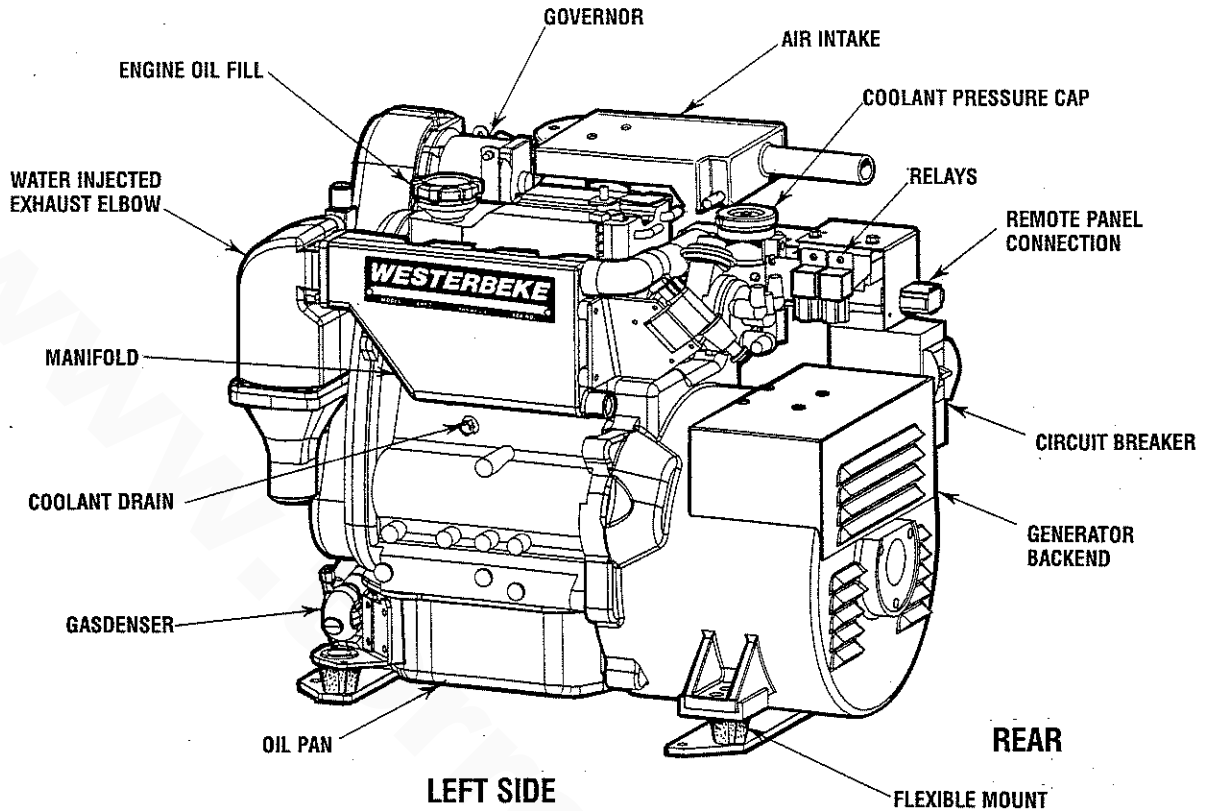

INTRODUCTION

This WESTERBEKE Generator is a product of WESTERBEKE'S long years of experience and advanced technology. We take great pride in the superior durability and dependable performance of our engines and generators. Thank you for selecting WESTERBEKE.

In order to get the full use and benefit from your generator, it is important that you operate and maintain it correctly. This manual is designed to help you do this. Please read this manual carefully and observe all the safety precautions throughout. Should your engine require servicing, contact your nearest WESTERBEKE dealer for assistance.

This is your Operators Manual. A Parts Catalog is also provided and a Technical Manual is available from your WESTERBEKE dealer. Also, if you are planning to install this equipment yourself, contact your WESTERBEKE dealer for WESTERBEKE'S Installation Manual.

WARRANTY PROCEDURES

Your WESTERBEKE Warranty is included in a separate folder. If you have not received a customer identification card registering your warranty 60 days after submitting the warranty registration form, please contact the factory in writing with model information, including the unit's serial number and commission date.



Customer Identification

WESTERBEKE OWNER
MAIN STREET
HOMETOWN, USA

Model BCGB Ser. #D703XXXX
 Expires 9/20/02

CUSTOMER IDENTIFICATION CARD (Typical)

The WESTERBEKE serial number is an alphanumeric number that can assist in determining the date of manufacture of your WESTERBEKE engine/generator. The first character indicates the decade (A=1960s, B=1970s, C=1980s, D=1990s), the second character represents the year in the decade, and the fourth and fifth number represents the month of manufacture.

PRODUCT SOFTWARE

Product software (tech data, parts lists, manuals, brochures and catalogs) provided from sources other than WESTERBEKE are not within WESTERBEKE'S CONTROL.

WESTERBEKE CANNOT BE RESPONSIBLE FOR THE CONTENT OF SUCH SOFTWARE, MAKES NO WARRANTIES OR REPRESENTATIONS WITH RESPECT THERETO, INCLUDING ACCURACY, TIMELINESS OR COMPLETENESS THEREOF AND WILL IN NO EVENT BE LIABLE FOR ANY TYPE OF DAMAGE OR INJURY INCURRED IN CONNECTION WITH OR ARISING OUT OF THE FURNISHING OR USE OF SUCH SOFTWARE.

WESTERBEKE customers should also keep in mind the time span between printings of WESTERBEKE product software and the unavoidable existence of earlier WESTERBEKE manuals. In summation, product software provided with WESTERBEKE products, whether from WESTERBEKE or other suppliers, must not and cannot be relied upon exclusively as the definitive authority on the respective product. It not only makes good sense but is imperative that appropriate representatives of WESTERBEKE or the supplier in question be consulted to determine the accuracy and currentness of the product software being consulted by the customer.

SERIAL NUMBER LOCATION

Fill in the information below for reference.

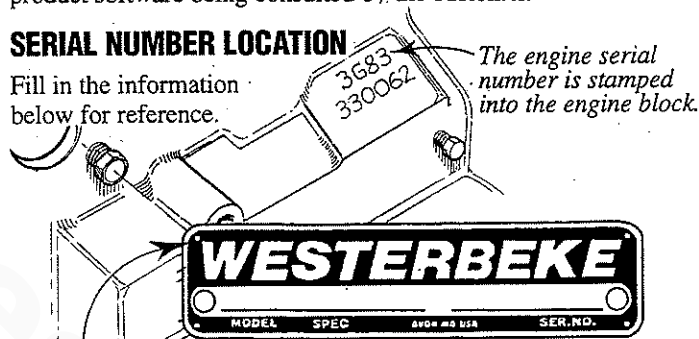

The engine model number and serial number are printed on a decal on the engine manifold.

The generator serial number is stamped on the top of the generator housing.

The generator specifications are printed on a decal on the side of the generator.

An additional decal is located on the top of the generator housing.

SPECIFICATION	50 HZ.	60 HZ.
MODEL		
RPM		
KW		
KVA		
VOLTS		
AMPS		
ENG. HP		
ENG. SER. NO.		
GEN. SER. NO.		
PF/PHASE		/
WIRES		
RATING		
INSUL. CLASS.		
TEMP. RISE		
BATTERY		
C.I.D.		

WESTERBEKE

IMPORTANT ENGINE INFORMATION

SER. NUM.	318321D812	THIS ENGINE CONFORMS TO PHASE I U.S. EPA REGULATIONS FOR SMALL NONROAD ENGINES. REFER TO OPERATOR'S MANUAL FOR MAINTENANCE SPECIFICATIONS AND ADJUSTMENTS.
DATE OF MFG.	1268	
FAMILY NAME	WX7XS.6602AG	THIS ENGINE IS CERTIFIED TO OPERATE ON REGULAR UNLEADED GASOLINE.
DISP. (CC)	660	
EMIS. CONT. SYS.	EM	P/N: 42084

INTRODUCTION

ORDERING PARTS

Whenever replacement parts are needed, always provide the generator and engine model and serial numbers. In addition, include a complete part description and part number for each part needed (see the separately furnished Parts Catalog). Also insist upon WESTERBEKE packaged parts because *will fit* or generic parts are frequently not made to the same specifications as original equipment.

NOTES, CAUTIONS AND WARNINGS

As this manual takes you through the operating procedures, maintenance schedules, and troubleshooting of your generator, critical information will be highlighted by NOTES, CAUTIONS, and WARNINGS. An explanation follows:

NOTE: *An operating procedure essential to note.*

CAUTION: *Procedures, which if not strictly observed, can result in the damage or destruction of the engine or generator.*

WARNING: *Procedures, which if not properly followed, can result in personal injury or loss of life.*

NOTE: *A carbon monoxide warning decal has been provided by WESTERBEKE. Affix this decal in a visible location in the engine room.*

SPARES AND ACCESSORIES

Certain spare parts will be needed to support and maintain your WESTERBEKE generator or engine when cruising (see *SUGGESTED SPARE PARTS*). Often even simple items such as proper fuel and oil filter can be difficult to obtain along the way. WESTERBEKE will provide you with a suggested spares and accessories brochure to assist you in preparing an on-board inventory of the proper WESTERBEKE parts.

PROTECTING YOUR INVESTMENT

Care at the factory during assembly and thorough testing have resulted in a WESTERBEKE generator capable of many thousands of hours of dependable service. However the manufacturer cannot control how or where the generator is installed in the vessel or the manner in which the unit is operated and serviced in the field. This is up to the buyer/owner-operator.

NOTE: *Six important steps to ensure long generator life:*

- *Proper engine and generator installation and alignment.*
- *An efficient well-designed exhaust system that includes an anti-siphon break to prevent water from entering the engine.*
- *Changing the engine oil and oil filters every 100 operating hours.*
- *Proper maintenance of all engine and generator components according to the maintenance schedule in this manual.*
- *Use clean, filtered unleaded fuel.*
- *Winterize your engine according to the "Lay-up and Recommissioning" section in this manual.*

UNDERSTANDING THE GASOLINE GENERATOR

The gasoline engine driving an AC generator is in many ways similar to a gasoline automobile engine. The cylinders are verticle in-line, and the engine's cylinder head has an overhead camshaft which is chain-driven. The engine utilizes a solid-state distributor which is horizontally mounted and camshaft-driven. The engine incorporates a pressure type lubrication system, and a fresh water-cooled engine block which is thermostatically-controlled. To a large degree, the generator's engine requires the same preventive maintenance that is required of a gasoline automobile engine. The most important factors to the generator's longevity are proper ventilation, maintenance of the fuel system, ignition system, cooling system and the generator backend.



FUEL, ENGINE OIL AND ENGINE COOLANT

GASOLINE

CAUTION: *Only use unleaded fuel with an octane rating of 89 or higher. Leaded fuel will cause serious harm to your engine and violate your warranty.*

CARE OF THE FUEL SUPPLY

Use only clean fuel! It is important to buy clean fuel, and keep it clean. The best fuel can be rendered unsatisfactory by careless handling or improper storage facilities. To assure that the fuel going into the tank for your engine's daily use is clean and pure, the following practice is advisable:

Purchase a well-known brand of fuel.

Install and regularly service a good, Coast Guard approved metal bowl type filter/water separator between the fuel tank and the engine.

ENGINE OIL

Use a heavy duty engine oil with an API classification of SJ. Change the engine oil after an initial 50 hours of break-in operation, and every 100 hours of operation thereafter. For recommended oil viscosity, see the following chart:

Operating Temperature	Oil Viscosity
Above 68° F (20° C)	SAE 30, 10W-30 or 15W-40
41° - 68° F (5°-20° C)	SAE 20 or 10W-30
Below 41° F (5° C)	SAE 10W-30

CAUTION: *Do not allow two or more brands of engine oil to mix. Each brand contains its own additives; additives of different brands could react in the mixture to produce properties harmful to your engine.*

ENGINE COOLANT

Westerbeke recommends a mixture of 50% antifreeze and 50% distilled water, when possible. Distilled water is free from the chemicals that can corrode internal engine surfaces.

The antifreeze performs double duty, as it allows the engine to run at proper temperatures by transferring heat away from the engine to the coolant. It also lubricates and protects the cooling circuit from rust and corrosion. Use a good quality antifreeze that contains supplemental cooling additives (SCAs) that keep the antifreeze chemically balanced, crucial to long term protection.

The water and antifreeze should be pre-mixed before being poured into the cooling circuit.

NOTE: *Use the new environmentally-friendly long lasting antifreeze that is now available.*

ANTIFREEZE PROTECTION CHART

Antifreeze concentration	23%	30%	35%	50%
Freezing Temperature	14° F	8° F	-4° F	-40° F
	(-10°C)	(-13°C)	(-20°C)	(-40°C)

COOLANT RECOVERY TANK

A coolant recovery tank kit is supplied with each generator. The purpose of this recovery tank is to allow for engine coolant expansion and contraction during engine operation, without the loss of coolant and without introducing air into the cooling system.

CONTROL PANELS

GENERATOR CONTROL PANEL

The ON and START/STOP switches are the only functional components to operate the generator at the engine. Both switches are used to start the generator - see *Starting the Generator* under *OPERATING INSTRUCTIONS*.

The ON switch is a two-position switch with momentary contacts in the up (*on*) position and a stationary contact function in the center position. This switch energizes the fuel pump.

The START/STOP switch is a three-position switch with momentary contacts in the up (*start*) position and a stationary contact function in the center and down (*stop*) positions. The center (*normal*) position allows the generator to be run, once started, and also enables the remote panel(s) to control the start/stop functions. The up (*start*) position starts the generator and once released, reverts to the center position. The down *stop* position stops the engine in normal operation as well as in an emergency situation, as it directly (unlike the remote panel stop switch) controls power to the starter, fuel pump and injector, and ignition relay coils, thus stopping the engine should a malfunction occur. During times when maintenance is being performed on the generator, the START/OFF switch should be placed in the stationary (*off*) position. This will disable the remote control panel(s), preventing attempts to start the generator from their locations. However, it is always best to disconnect the battery during this time if it is not required to perform the maintenance.

REMOTE PANEL

There are three functional components on the remote panel for generator operation:

1. ON switch
1. START/STOP switch
2. Green LED indicator light

The ON switch is a two-position switch with momentary contacts in the up (*on*) position and a stationary contact function in the center position. This switch energizes the fuel pump.

The START/STOP switch is a three-position switch with momentary contact functions in the up (*start*) and down (*stop*) positions, and a stationary contact function in the center position. The center position is a dual OFF/RUN mode position and is normally in the *off* mode. When in the *start* (up) position, this switch starts the generator (together with the ON switch in the up position) and once released, reverts to the center position, *run* mode. When in the *stop* (down) position, this switch stops the generator, and once released, reverts to the center position, *off* mode.

The Green LED indicator light indicates the engine running condition. It lights when the ON switch is moved to the *start* position, dims when the engine is cranking, and brightens when the engine starts, notifying the operator to release the START switch.

GENERATOR CONTROL PANEL

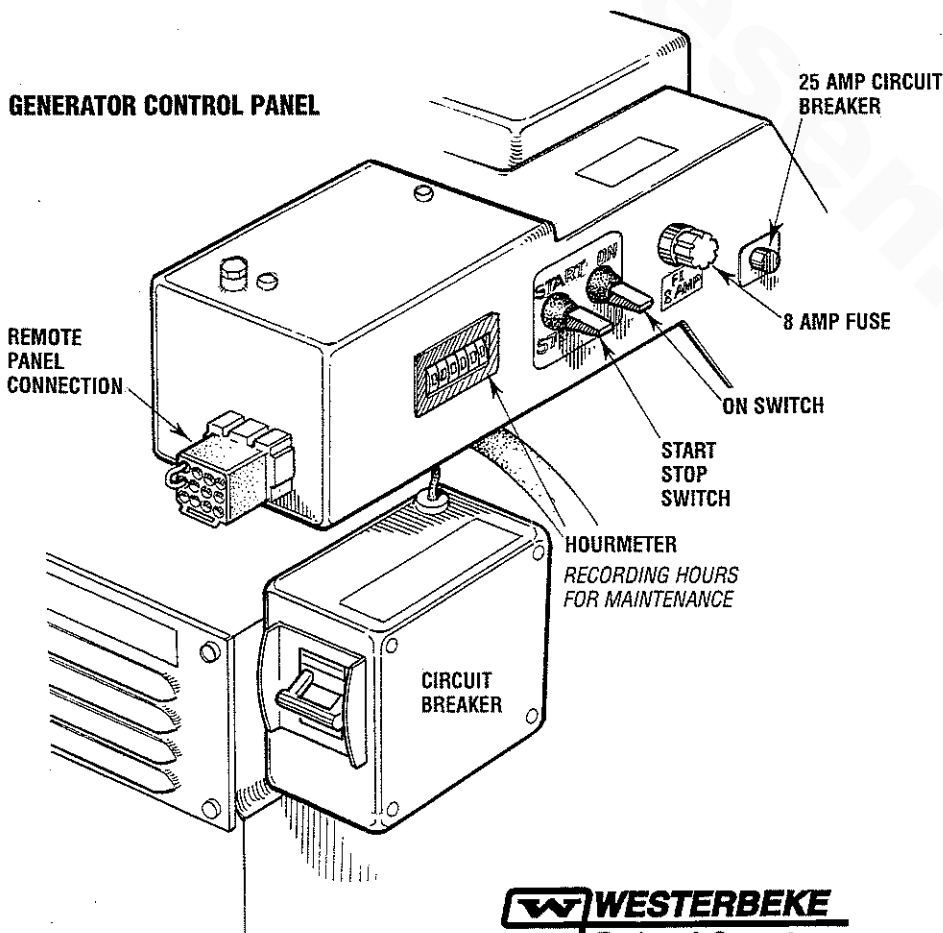

REMOTE PANEL



PREPARATIONS FOR INITIAL START-UP

PRESTART INSPECTION

Before starting your generator for the first time or after a prolonged layoff, check the following items:

- Check the engine oil level: add oil to maintain the level at the full mark on the dipstick.
- Check the fuel supply and examine the fuel filter/separator bowls for contaminants.
- Check the DC electrical system. Inspect wire connections and battery cable connections.
- Check the coolant level in both the plastic recovery tank and at the manifold.

NOTE: After the initial running of the generator, the air in the engine's cooling system will be purged to the coolant recovery tank. Open the air bleed petcock to ensure that the cooling system is purged of air. After shutdown and after the engine has cooled, the coolant from the recovery tank will be drawn into the engine's cooling system to replace the purged air.

Before subsequent operation of the generator, the engine's manifold should be topped off, and the coolant recovery tank may need to be filled to the MAX level.

- Visually examine the unit. Look for loose or missing parts, disconnected wires, unattached hoses, and check threaded connections. Search for any gasoline leaks.
- Check load leads for correct connections as specified in the wiring diagrams.
- Examine the air inlet and outlet for air flow obstructions.
- Be sure no other generator or utility power is connected to the load lines.
- Be sure that in power systems with a neutral line that the neutral is properly grounded (or ungrounded) as the system requires, and that generator neutral is properly connected to the load neutral. In single phase systems an incomplete or open neutral can supply the wrong line-to-neutral voltage on unbalanced loads.

CAUTION: When starting the generator, it is recommended that all AC loads, especially large motors, be switched OFF until the engine has come up to speed and, in cold climates, starts to warm up. This precaution will prevent damage caused by unanticipated operation of the AC machinery and will prevent a cold engine from stalling.

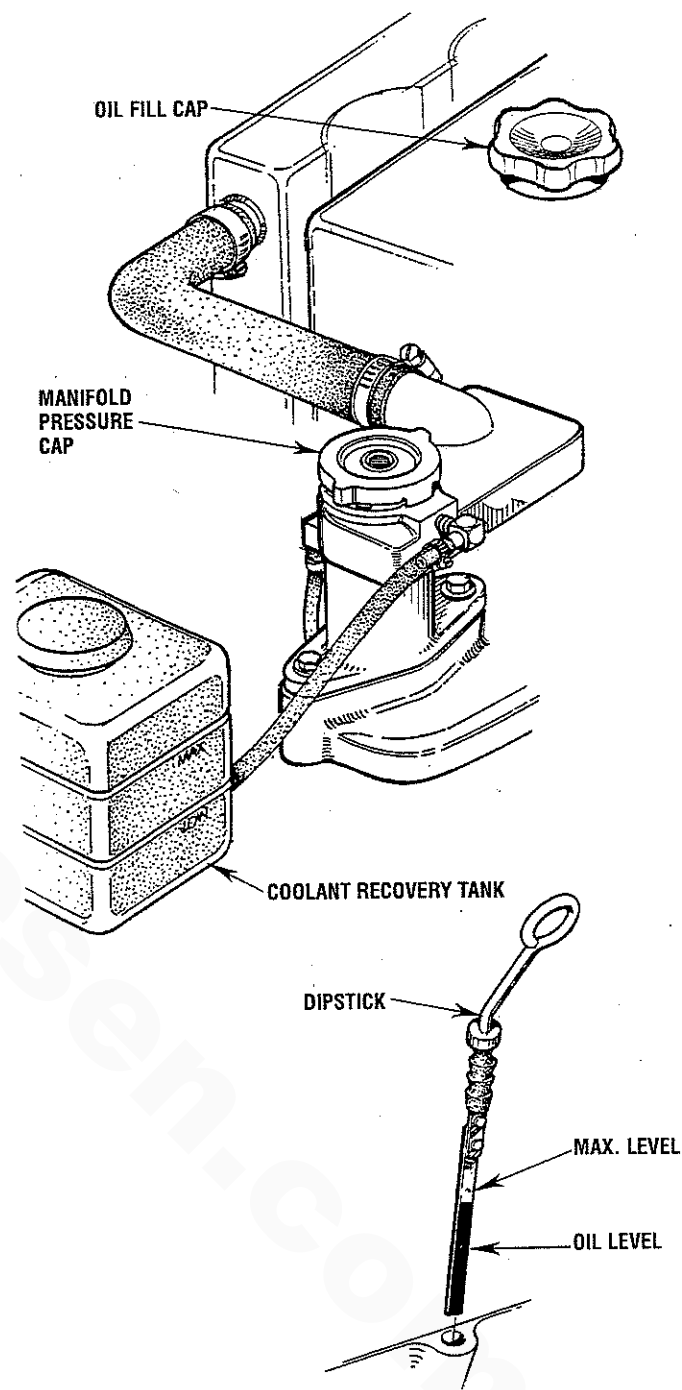

OPERATING INSTRUCTIONS

GENERATOR CONTROL PANEL

Starting the Generator

To start the generator, hold the momentary ON switch in the up (*on*) position, then hold the momentary START/STOP switch in the up (*start*) position (both switches are held up together). After approximately one second, the starter will engage and the engine will crank. Once the engine is running, the starter will disengage, and the START/STOP switch may then be released to return to its center (*run mode*) position. Continue holding the ON switch until the engine has sufficient oil pressure, then release it to its center position.

NOTE: Should the engine fail to start, release both switches, wait 20 seconds, and try again. Never run the starter more than 20 seconds at a time.

START/STOP SWITCH

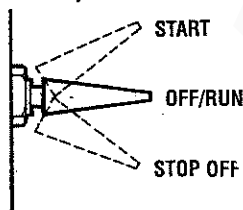

ON SWITCH

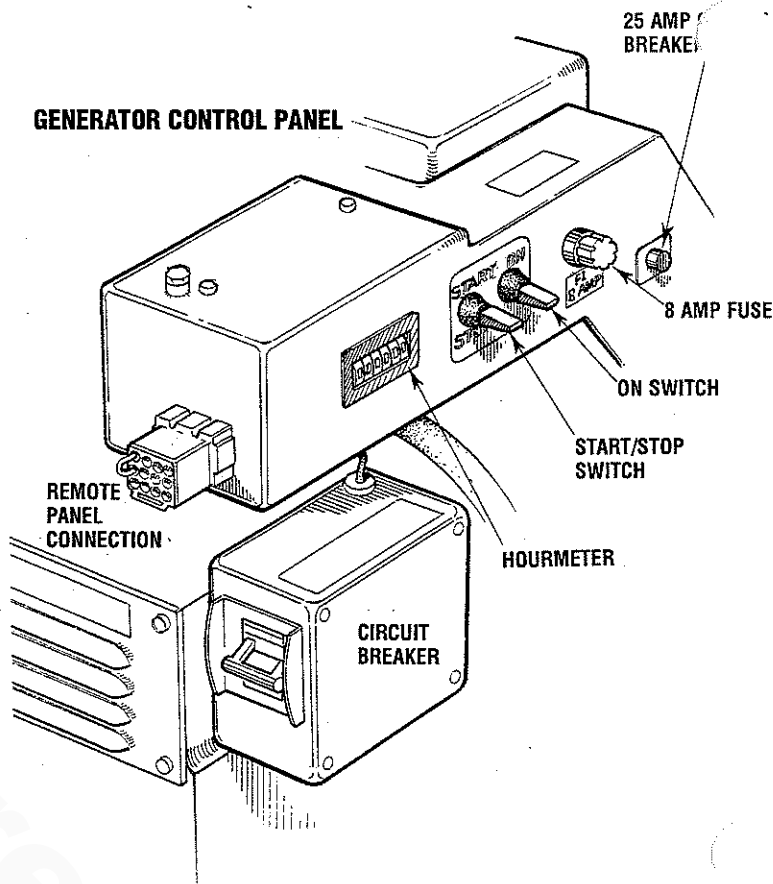
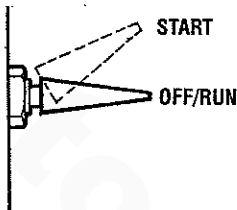

Starting under Cold Conditions

Make certain the lubricating oil conforms with the ratings for the prevailing temperature. Check the table under *ENGINE LUBRICATING OIL*. The battery should be fully charged to minimize voltage drop.

Stopping the Generator

To stop the generator, move the momentary START/STOP switch to the down (*off*) position then release it to the center (normal) position.

EMERGENCY STOPPING

If the generator does not stop using the START/STOP switch, remove the 8 amp fuse or disconnect the battery.

CAUTION: Prolonged cranking intervals without the engine starting can result in filling the engine exhaust system with raw water. This may happen because the pump is pumping raw water through the raw water cooling system during cranking. This raw water can enter the engine's cylinders by way of the exhaust manifold once the exhaust system fills. Prevent this from happening by closing the raw water supply through-hull shutoff, draining the exhaust muffler, and correcting the cause of the excessive engine cranking. Engine damage resulting from raw water entry is not a warrantable issue; the owner/operator should keep this in mind.

Abnormal Stop

An abnormal stop is one in which the generator ceases to run and comes to a stop as a result of an operating fault which may cause damage to the engine, the generator, or create an unsafe operating condition. The fault stop conditions are:

1. Overspeed condition.
2. High engine temperature.
3. Low oil pressure.
4. High exhaust temperature.

Should a fault condition occur, the engine will shutdown. On the remote panel the green LED light will turn off indicating an engine shutdown. Once detected, the fault should be located and corrected (see *ENGINE TROUBLESHOOTING*).

OPERATING INSTRUCTIONS

REMOTE PANEL

Starting the Generator

To start the generator, hold the momentary ON switch in the up (*on*) position (the green light will come on), then hold the momentary START/STOP switch in the up (*start*) position (both switches are held up together). After approximately one second, the starter will engage and the engine will crank (the green light will dim). Once the engine is running (the green light will brighten), the starter will disengage, and the START/STOP switch may then be released to return to its center (*run mode*) position. Continue holding the ON switch until the engine has sufficient oil pressure, then release it to its center position.

NOTE: Should the engine fail to start, release both switches, wait 20 seconds, and try again. Never run the starter more than 20 seconds at a time.



REMOTE PANEL

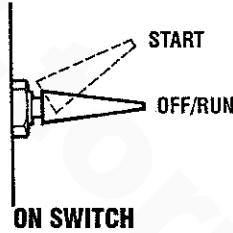
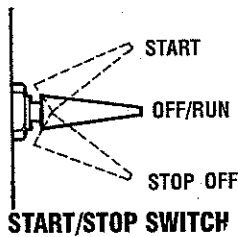

Stopping the Generator

To stop the generator, move the momentary START/STOP switch to the down (*stop*) position then release it to the center (*off/run mode*) position. This will de-energize the K2 run relay in the generator's control panel and stop the generator.

BREAK-IN PROCEDURE/DAILY OPERATION

BREAK-IN PROCEDURE

After the generator has been started, check for proper operation and then encourage a fast warm-up. Run the generator between 20% to 60% of full load for the first 10 hours.

CAUTION: Do not attempt to break-in your generator by running without a load.

After the first 10 hours of the generators' operation, the load can be increased to the full-load rated output; then periodically vary the load.

Avoid overload at all times. An overload is signaled by a smoky exhaust with reduced output voltage and frequency. Monitor the current being drawn from the generator and keep it within the generators' rating. Since the generator operates at 1800 rpm to produce 60 hertz, or at 1500 to produce 50 hertz, control of the generator's engine break-in is governed by the current drawn from the generator.

To protect against unintentional overloading of the generator, the generator's output leads should be routed through a circuit breaker that is rated at the rated output of the generator.

NOTE: Be aware of motor starting loads and the high current drawn required for starting motors. This starting amperage drawn can be 3 to 5 times normal running amperage. See *GENERATOR INFORMATION* in this manual.

CHECK LIST

Follow this checklist each day before starting your generator.

- Record the hourmeter reading in your log (engine hours relate to the maintenance schedule).
- Visually inspect the engine for fuel, oil, or water leaks.
- Check the oil level (dipstick).
- Check the coolant level in the coolant recovery tank.
- Check your fuel supply.
- Check the starting batteries (weekly).
- Check the drive belt for wear and proper tension (weekly).
- Check for abnormal noise such as knocking, vibration and blow-back sounds.
- Confirm exhaust smoke:
 - When the engine is cold – White Smoke.
 - When the engine is warm – almost Smokeless.
 - When the engine is overloaded – some Black Smoke.

NOTE: Some unstable running may occur in a cold engine. This condition should abate as normal operating temperature is reached and loads are applied.

CAUTION: Do not operate the generator for long periods of time without a load being placed on the generator.

STOPPING THE GENERATOR

Remove the major AC loads from the generator one at a time. Allow the generator to run for a few minutes to stabilize the operating temperature and press the STOP switch down, (see *CONTROL PANELS*).

NOTE: After the first 50 hours of generator operation check the maintenance schedule for the 50 hour service check.

GENERATOR ADJUSTMENTS

Once the generator has been placed in operation, there may be governor adjustments required for engine speed (hertz) during the engine's break-in period (first 50 hours) or after this period (see *ENGINE SPEED (HERTZ) ADJUSTMENT* under *ENGINE ADJUSTMENTS*). A no-load voltage adjustment may also be required in conjunction with the engine's speed adjustment (see *GENERATOR INFORMATION*).

SAFETY SHUTDOWN SWITCHES

SAFETY SHUTDOWN SWITCHES

The engine is protected by a variety of shutdown switches. Should a shutdown occur, **do not attempt to restart without finding and correcting the cause.** Refer to the heading *Engine starts, runs and then shuts down* in the **ENGINE TROUBLESHOOTING** section of this manual.

The following is a description of these automatic shutdown switches:

High Exhaust Temperature Switch

An exhaust temperature switch is located on the exhaust elbow. Normally closed, this switch will open and interrupt the DC voltage to the K2-run relay (shutting off the engine) should the switch's sensor indicate an excessive exhaust temperature (an inadequate supply of raw water causes high exhaust temperatures). This switch opens at 260-270°F (127-132°C). This switch resets at approximately 225°F (107°C).

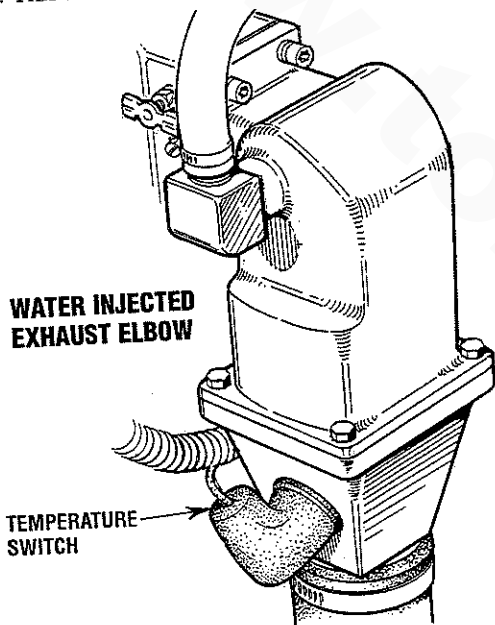

High Water Temperature Switch

A high water temperature switch is located at the thermostat housing. Normally closed, this switch, should the fresh water coolant's operating temperature reach approximately 210°F (99°C), will open and interrupt the DC voltage to the K2 run relay thereby shutting off the engine. This switch resets at 195°F (107°C).

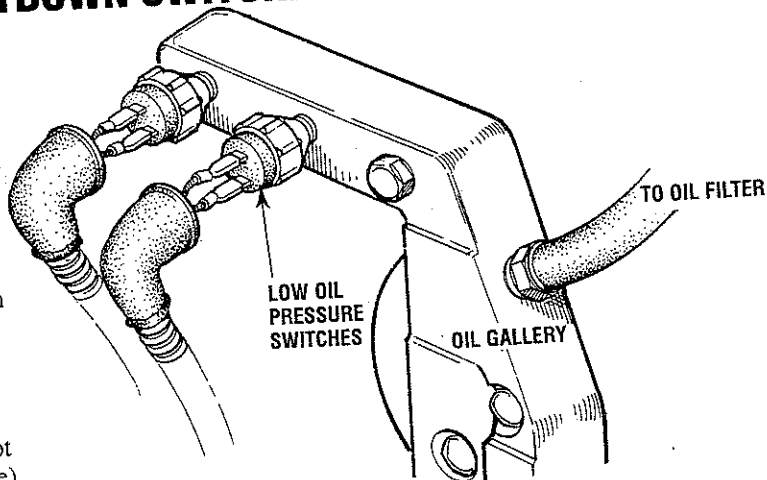
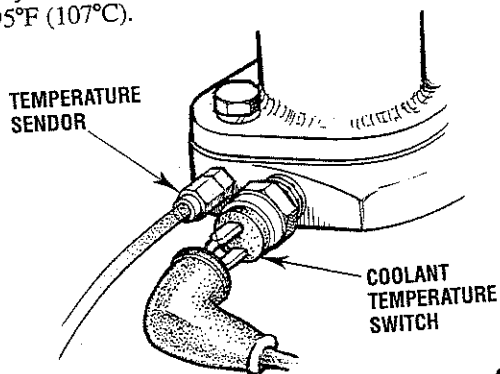

Low Oil Pressure Switch

Dual low oil pressure switches are located off the engine's oil gallery manifold. One is normally open when the engine is in a static state. This switch functions in the automatic shutdown circuit when the unit is operating (5 psi rating). The second oil pressure switch is installed *only* on SEA RAY spec. generators. This switch is normally closed and functions in their low oil pressure alarm system (10 psi rating).

Should the oil pressure drop to 10 psi while the generator is operating, the SEA RAY spec. switch will close activating their low oil pressure alarm. Should the oil pressure drop further to 5 psi, the automatic shutdown circuit switch will open interrupting DC voltage to the K2 run relay thereby shutting off the generator.

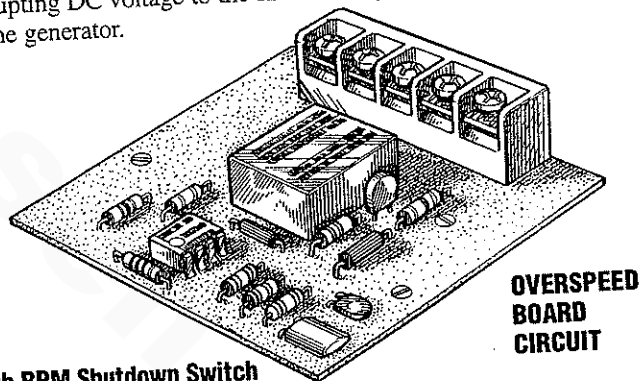

High RPM Shutdown Switch

An overspeed switch in the DC circuit shuts off the generators engine by interrupting DC voltage to the K2 run relay if the engine's speed reaches 2175 rpm (approximately). After correcting the problem, this switch can be reset by momentarily depressing the stop switch. Refer to the **WIRING DIAGRAMS** in this manual.

Engine Circuit Breaker

The generator's engine is protected by an engine mounted manual reset circuit breaker (20 amps DC). Excessive current draw or electrical overload anywhere in the instrument panel wiring or engine wiring will cause the breaker to trip. In this event the generator will shut down because the opened breaker interrupts the DC circuit to the K2-run relay. If this should occur, check and repair the source of the problem. After repairing the fault, reset the breaker and restart the generator.

MAINTENANCE SCHEDULE

⚠ WARNING: *Never attempt to perform any service while the engine is running. Wear the proper safety equipment such as goggles and gloves, and use the correct tools for each job. Disconnect the battery terminals when servicing any of the engine's DC electrical equipment.*

NOTE: *Many of the following maintenance procedures are simple but others are more difficult and may require the expert knowledge of a service mechanic.*

SCHEDULED MAINTENANCE	CHECK EACH DAY	HOURS OF OPERATION							EXPLANATION OF SCHEDULED MAINTENANCE
		50	100	250	500	750	1000	1250	
Fuel Supply	<input type="checkbox"/>								Unleaded gasoline with octane rating of 89 or higher.
Fuel/Water Separator	<input type="checkbox"/>								Check for water and dirt in fuel (drain/replace filter if necessary).
Engine Oil Level	<input type="checkbox"/>								Oil level should indicate between FULL and LOW on dipstick.
Coolant Level	<input type="checkbox"/>								Check at recovery tank; if empty, check at manifold. Add coolant if needed.
Drive Belt	<input type="checkbox"/> weekly								Inspect for proper tension (3/8" to 1/2" deflection) and adjust if needed. Check belt edges for wear.
Visual Inspection of Engine	<input type="checkbox"/>	NOTE: <i>Keep engine surface clean. Dirt and oil will inhibit the engine's ability to remain cool.</i>							Check for fuel, oil and water leaks. Inspect wiring and electrical connections. Keep bolts & nuts tight. Check for loose belt tension.
Spark Plugs		<input type="checkbox"/>		<input type="checkbox"/>	<input type="checkbox"/>	<input type="checkbox"/>	<input type="checkbox"/>	<input type="checkbox"/>	Check gap; inspect for burning and corrosion.
Generator		<input type="checkbox"/>	<input type="checkbox"/>	<input type="checkbox"/>	<input type="checkbox"/>	<input type="checkbox"/>	<input type="checkbox"/>	<input type="checkbox"/>	Check that AC connections are clean and secure with no chafing – see <i>GENERATOR INFORMATION</i> for additional information.
Fuel Filter		<input type="checkbox"/>		<input type="checkbox"/>	<input type="checkbox"/>	<input type="checkbox"/>	<input type="checkbox"/>	<input type="checkbox"/>	Initial change at 50 hrs, then change every 250 hrs.
Carburetor Filter Screen		<input type="checkbox"/>		<input type="checkbox"/>	<input type="checkbox"/>	<input type="checkbox"/>	<input type="checkbox"/>	<input type="checkbox"/>	Initial change at 50 hrs, then change every 250 hrs.
Starting Batteries (and House Batteries)	<input type="checkbox"/> weekly	<input type="checkbox"/>							Every 50 operating hours check electrolyte levels and make sure connections are very tight. Clean off excessive corrosion.
Engine Oil		<input type="checkbox"/>	<input type="checkbox"/>	<input type="checkbox"/>	<input type="checkbox"/>	<input type="checkbox"/>	<input type="checkbox"/>	<input type="checkbox"/>	Initial engine oil & filter change at 50 hrs., then change both every 100 hours.
*Adjust the Valve Clearances		<input type="checkbox"/>		<input type="checkbox"/>		<input type="checkbox"/>			Initial adjustment at 50 hrs., then every 500 hrs.
Air Screen (Flame Arrester)		<input type="checkbox"/>							Clean at 50 hours, then every 100 hours.
Exhaust System		<input type="checkbox"/>		<input type="checkbox"/>		<input type="checkbox"/>		<input type="checkbox"/>	Initial check at 50 hrs., then every 250 hrs. Inspect for leaks. Check siphon brake operation. Check the exhaust elbow for carbon and/or corrosion buildup on inside passages; clean and replace as necessary. Check that all connections are tight.
Engine Hoses			<input type="checkbox"/>	<input type="checkbox"/>	<input type="checkbox"/>	<input type="checkbox"/>	<input type="checkbox"/>	<input type="checkbox"/>	Hose should be hard & tight. Replace if soft or spongy. Check and tighten all hose clamps.

*WESTERBEKE recommends this service be performed by an authorized mechanic.

(continued)



MAINTENANCE SCHEDULE

NOTE: Use the engine hourmeter gauge to log your engine hours or record your engine hours by running time.

SCHEDULED MAINTENANCE	CHECK EACH DAY	HOURS OF OPERATION							EXPLANATION OF SCHEDULED MAINTENANCE
		50	100	250	500	750	1000	1250	
Heat Exchanger		<input type="checkbox"/>	<input type="checkbox"/>	<input type="checkbox"/>	<input type="checkbox"/>	<input type="checkbox"/>	<input type="checkbox"/>	<input type="checkbox"/>	Clean or replace anode. Open heat exchanger end cap and clean out debris. Remove every 1000 hours for professional cleaning and pressure testing.
Raw Water Pump				<input type="checkbox"/>		<input type="checkbox"/>		<input type="checkbox"/>	Remove pump cover and inspect impeller for wear; replace if needed. Also replace gasket. Lubricate both when reassembling.
Coolant System						<input type="checkbox"/>			Drain, flush, and refill cooling system with appropriate antifreeze mix.
*Starter Motor					<input type="checkbox"/>			<input type="checkbox"/>	Check solenoid and motor for corrosion. Remove and lubricate. Clean and lubricate the Start motor pinion drive.
Distributor		<input type="checkbox"/>			<input type="checkbox"/>				Check ignition timing. Check condition of distributor cap and rotor.
*Engine Cylinder Compression and Valve Clearance					<input type="checkbox"/>			<input type="checkbox"/>	Incorrect valve clearance will result in poor engine performance; check compression pressure and timing, and adjust valve clearances.
*Engine Timing Belt							<input type="checkbox"/>		Remove and replace every 1000 hours. NOTE: Failure to replace the timing belt at the recommended interval could result in timing belt failure resulting in major damage to the engine.
*Exhaust Elbow					<input type="checkbox"/>				Test exhaust elbow for casting integrity. Replace if casting is corroded or deteriorated. WARNING: A defective exhaust elbow can cause carbon monoxide leakage!

*WESTERBEKE recommends this service be performed by an authorized mechanic.



COOLING SYSTEM

DESCRIPTION

Westerbeke marine engines are designed and equipped for fresh water cooling. Heat produced in the engine by combustion and friction is transferred to fresh water coolant which circulates throughout the engine. This circulating fresh water coolant cools the engine block, its internal moving parts, and the engine oil. The heat is transferred externally from the fresh water coolant to raw water by means of a heat exchanger, similar in function to an automotive radiator. Raw water flows through the tubes of the heat exchanger while fresh water coolant flows around the tubes; engine heat transferred to the fresh water coolant is conducted through the tube walls to the raw water which is then pumped into the exhaust system where finally it is discharged overboard.

In other words, the engine is cooled by fresh water coolant, this coolant is cooled by raw water, and the raw water carries the transferred heat overboard through the exhaust system. The fresh water coolant and raw water circuits are independent of each other. Using only fresh water coolant within the engine allows the cooling water passages to stay clean and free from harmful deposits.

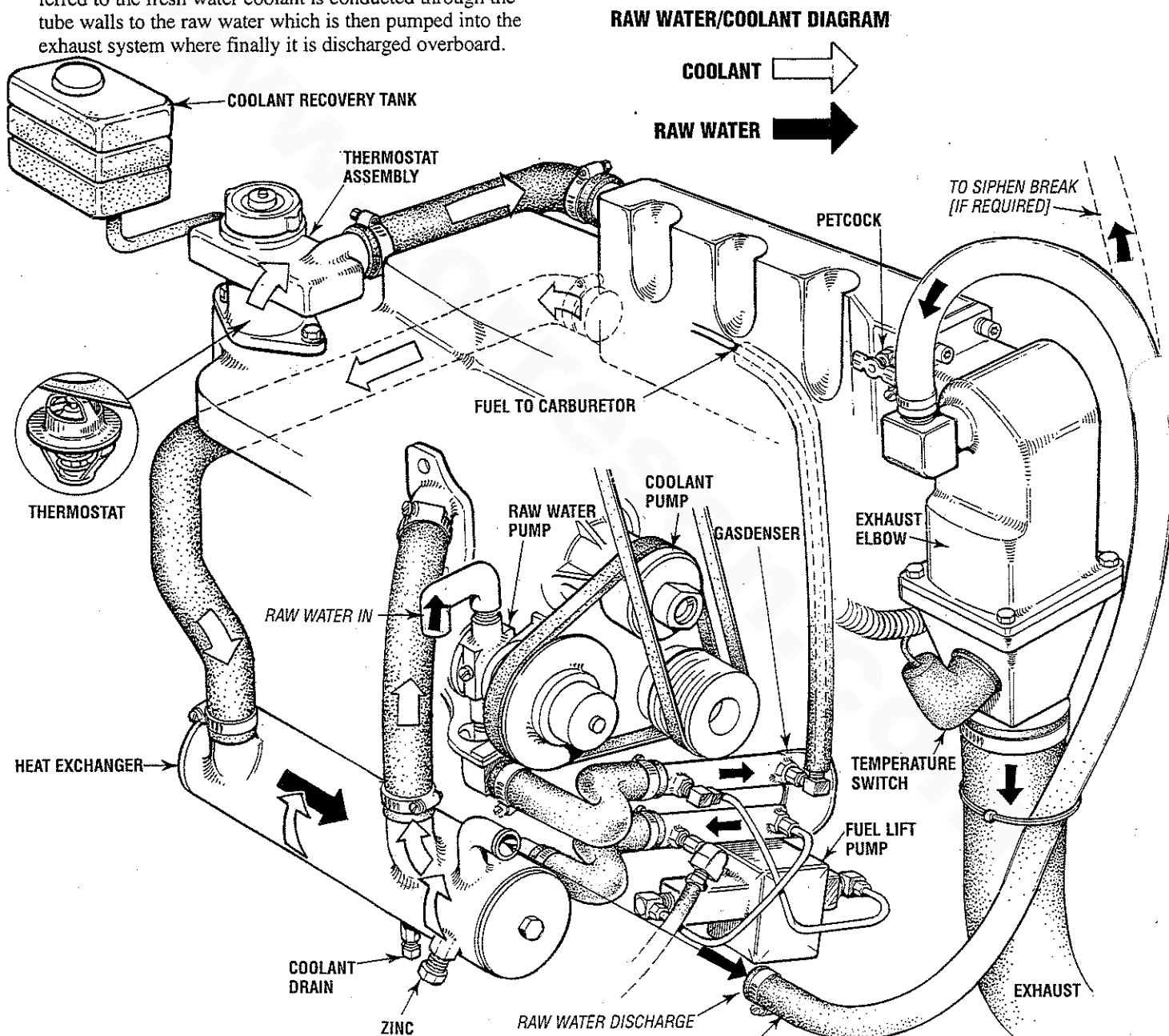

COOLING SYSTEM

FRESH WATER COOLING CIRCUIT

NOTE: Refer to the *ENGINE COOLANT* section for the recommended antifreeze and water mixture to be used as the fresh water coolant.

Fresh water coolant is pumped through the engine by a circulating pump, absorbing heat from the engine. The coolant then passes through the thermostat into the manifold, to the heat exchanger where it is cooled, and returned to the engine block via the suction side of the circulating pump. When the engine is started cold, external coolant flow is prevented by the closed thermostat (although some coolant flow is bypassed around the thermostat to prevent the exhaust manifold from overheating). As the engine warms up, the thermostat gradually opens, allowing full flow of the engine's coolant to flow unrestricted to the external portion of the cooling system.

Coolant Recovery Tank

A coolant recovery tank allows for engine coolant expansion and contraction during engine operation, without any significant loss of coolant and without introducing air into the cooling system. This tank should be located at or above the engine manifold level and should be easily accessible.

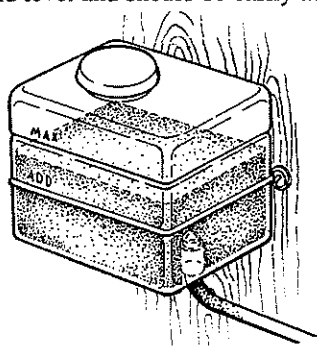

NOTE: Periodically check the condition of the manifold pressure cap. Ensure that the upper and lower rubber seals are in good condition and check that the vacuum valve opens and closes tightly. Carry a spare cap.

CHANGING COOLANT

The engine's coolant must be changed according to the *MAINTENANCE SCHEDULE*. If the coolant is allowed to become contaminated, it can lead to overheating problems.

CAUTION: Proper cooling system maintenance is critical; a substantial number of engine failures can be traced back to cooling system corrosion.

Drain the engine coolant by removing the drain plug on the engine block and opening the manifold pressure cap. Flush the system with fresh water, then reinstall the drain and start the refill process.

NOTE: The drain petcock on the heat exchanger should also be used to help drain engine coolant.

WARNING: Beware of the hot engine coolant. Wear protective gloves.

Refilling the Coolant

After replacing the engine block drain plug, close the heat exchanger's coolant petcock. Then run the engine at idle and slowly pour clean, premixed coolant into the manifold.

Monitor the coolant in the manifold and add as needed. Fill the manifold to the filler neck and install the manifold pressure cap.

Remove the cap on the coolant recovery tank and fill with coolant mix to halfway between LOW and MAX and replace the cap. Run the engine and observe the coolant expansion flow into the recovery tank.

After checking for leaks, stop the engine and allow it to cool. Coolant should draw back into the cooling system as the engine cools down. Add coolant to the recovery tank if needed and check the coolant in the manifold. Clean up any spilled coolant.

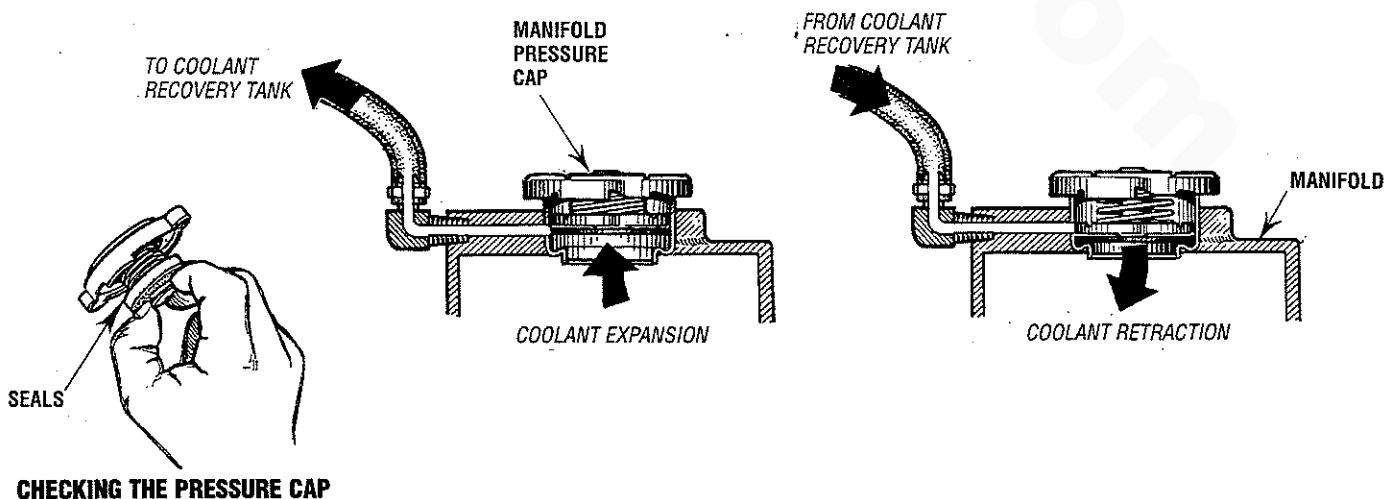

COOLING SYSTEM

THERMOSTAT

A thermostat controls the coolant temperature as the coolant continuously flows through the closed cooling circuit. When the engine is first started the closed thermostat prevents coolant from flowing (some coolant is by-passed around the thermostat to prevent the exhaust manifold from over-heating). As the engine warms up, the thermostat gradually opens. The thermostat is accessible and can be checked, cleaned, or replaced easily. Carry a spare thermostat and gasket.

Replacing the Thermostat

Remove the cap screws and disassemble the thermostat housing as shown. When installing the new thermostat and gasket, apply a thin coat of sealant on both sides of the gasket before pressing it into place. Do not over-tighten the cap screws.

Run the engine and check for normal temperatures and that there are no leaks at the thermostat housing.

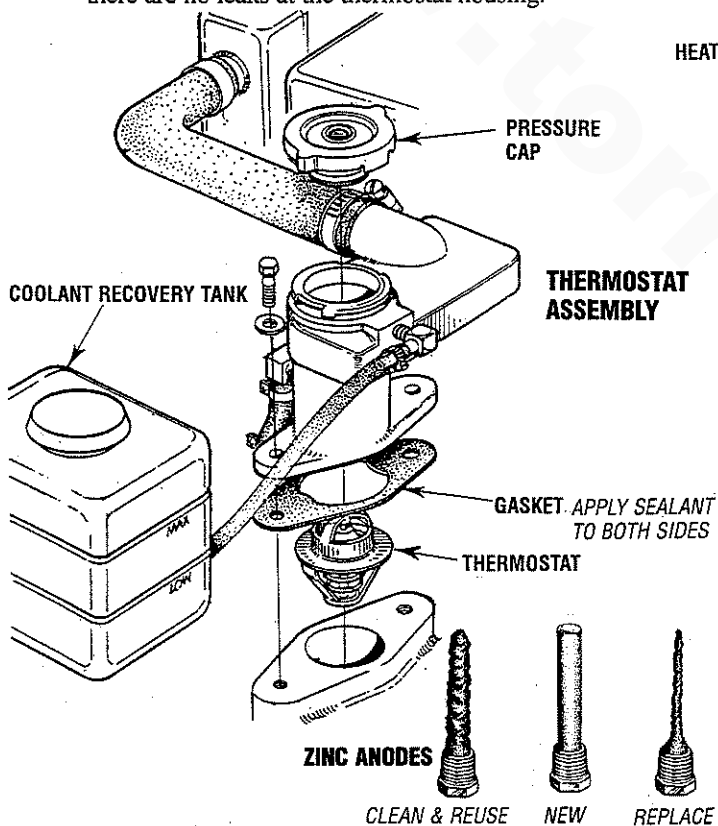

ZINC ANODE

A zinc anode (or pencil) is located in the raw water cooling circuit within the heat exchanger. The purpose of the zinc anode is to sacrifice itself to electrolysis action taking place in the raw water cooling circuit, thereby reducing the effects of electrolysis on other components of the system. The condition of the zinc anode should be checked monthly and the anode cleaned or replaced, as required. Spare anodes should be carried onboard.

NOTE: Electrolysis is the result of each particular installation and vessel location, not that of the engine.

If the zinc anodes need replacement, hold the hex boss into which the zinc anode is threaded with a wrench while loosening the anode with another wrench. This prevents the hex boss from possibly tearing off the exchanger shell. After removing the zinc, note the condition of it. If the zinc is in poor condition, there are probably a lot of zinc flakes within the exchanger. Remove the end of the heat exchanger and clean the inside of all zinc debris. Always have a spare heat exchanger end gasket in case the present one becomes damaged when removing the end cover. Replace the gasket (refer to your engine model's heat exchanger end gasket part number), O-ring and cover, and install a new zinc anode.

NOTE: The threads of the zinc anodes are pipe threads and do not require sealant. Sealant should not be used as it may insulate the zinc from the metal of the heat exchanger housing preventing electrolysis action on the zinc.

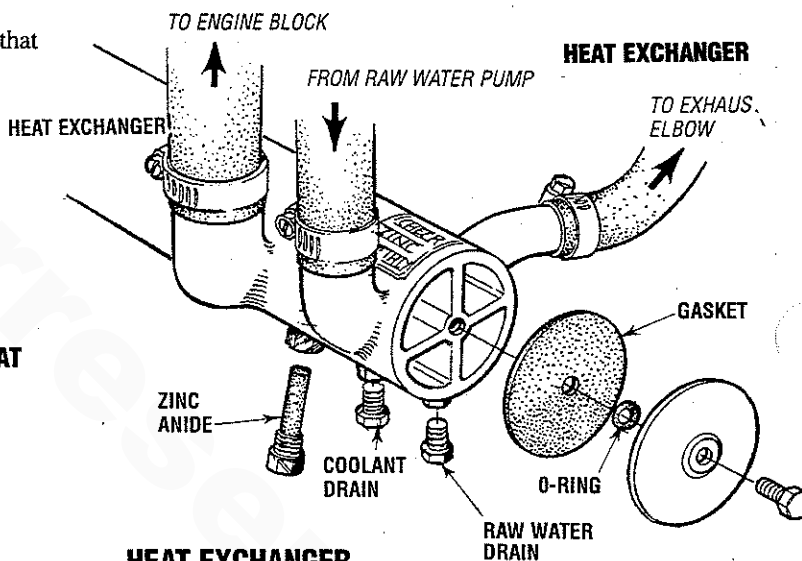

HEAT EXCHANGER

Cool raw water flows through the inner tubes of the heat exchanger. As the engine coolant passes around these tubes the heat of the internal engine is conducted to the raw water which is then pumped into the exhaust system and discharged. The engine coolant (now cooled) flows back through the engine and the circuit repeats itself.

The engine coolant and raw water are independent of each other; this keeps the engine's water passages clean from the harmful deposits found in raw water.

Heat Exchanger Service

After approximately 1000 hours of operation, remove, clean and pressure test the engine's heat exchanger. (A local automotive radiator shop should be able to clean and test the heat exchanger).

NOTE: Operating in silty and/or tropical waters may require that a heat exchanger cleaning be performed more often than every 1000 hours.



COOLING SYSTEM

RAW WATER INTAKE STRAINER

NOTE: Always install the strainer at or below the waterline so the strainer will always be self-priming.

A clean raw water intake strainer is a vital component of the engine's cooling system. Include a visual inspection of this strainer when making your periodic engine check. The water in the glass should be clear.

Perform the following maintenance after every 100 hours of operation:

1. Close the raw water seacock.
2. Remove and clean the strainer filter.
3. Clean the glass.
4. Replace the washer if necessary.
5. Reassemble and install the strainer.
6. Open the seacock.
7. Run the engine and check for leaks.

NOTE: Also follow the above procedure after having run hard aground.

If the engine temperature gauge ever shows a higher than normal reading, the cause may be that silt, leaves or grass may have been caught up in the strainer, slowing the flow of raw water through the cooling system

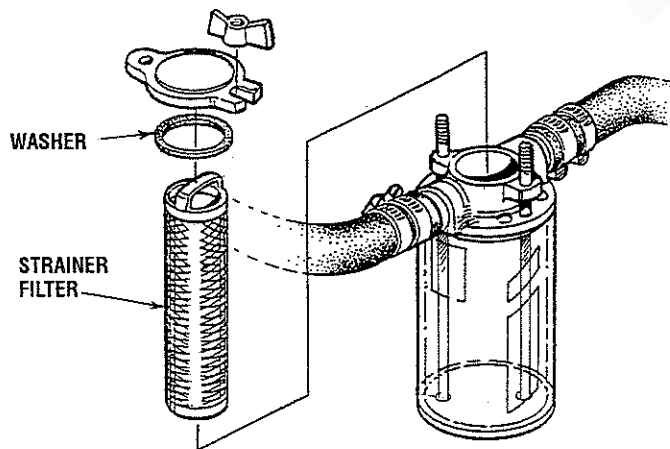

RAW WATER INTAKE STRAINER
OWNER/BUILDER INSTALLED

RAW WATER PUMP

The raw water pump is a self-priming, rotary pump with a non-ferrous housing and a Neoprene impeller. The impeller has flexible blades which wipe against a curved cam plate within the impeller housing, producing the pumping action. On no account should this pump be run dry. There should always be a spare impeller and impeller cover gasket aboard (an impeller kit). Raw water pump impeller failures occur when lubricant (raw water) is not present during engine operation. Such failures are not warrantable, and operators are cautioned to make sure raw water flow is present at start-up. The raw water pump should be inspected periodically for broken or torn impeller blades. See *MAINTENANCE SCHEDULE*.

NOTE: Should a failure occur with the pump's internal parts (seals and bearings), it may be more cost efficient to purchase a new pump and rebuild the original pump as a spare.

Changing the Raw Water Pump Impeller

Close the raw water intake valve. Remove the pump cover and, with the aid of two small screwdrivers, carefully pry the impeller out of the pump. Install the new impeller and gasket. Move the blades to conform to the curved cam plate and push the impeller into the pump's housing. When assembling, apply a thin coating of lubricant to the impeller and gasket. Open the raw water intake valve.

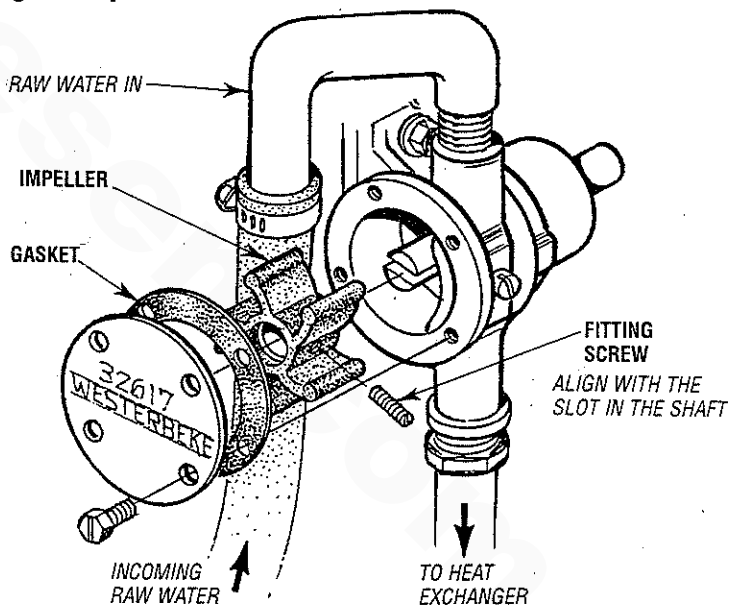

CAUTION: If any of the vanes have broken off the impeller, they must be located to prevent blockage in the cooling circuit. They often can be found in the heat exchanger.

FUEL SYSTEM

GASOLINE

Use *unleaded* 89 octane or higher gasoline. When fueling, follow U.S. Coast Guard regulations, close off all hatches and companionways to prevent fumes from entering the boat, and ventilate after fueling.

NOTE: *The generator compartment should have a gasoline fume detector/alarm properly installed and working.*

⚠ WARNING: *Shut off the fuel valve at the tank when servicing the fuel system. Take care in catching any fuel that may spill. DO NOT allow any smoking, open flames or other sources of fire near the fuel system when servicing. Ensure proper ventilation exists when servicing the fuel system.*

CARBURETOR

The carburetor is a single barrel downdraft type with a solenoid activated electric choke and electric fuel shutoff solenoid. Refer to *CARBURETOR ADJUSTMENTS* for more information.

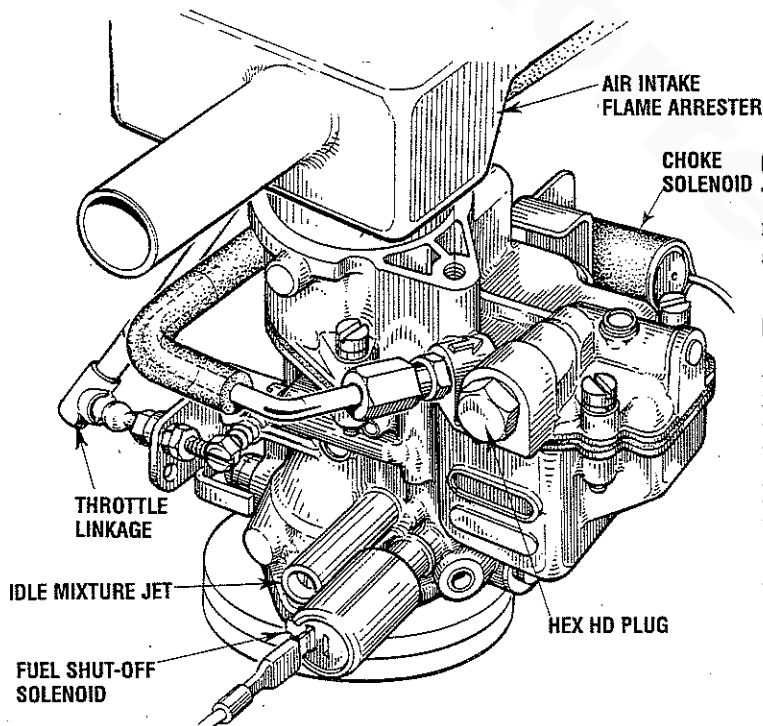

FUEL LIFT PUMP

Periodically check the fuel connections to and out of the pump and make sure that no leakage is present and that the fittings are tight and secure. The DC ground connection at one of the pump's mounting bolts should be clean and well secured by the mounting bolt to ensure proper pump operation.

The engine mounted fuel lift pump is maintenance free. It is located at the front of the engine under the gasdenser.

⚠ WARNING: *Fuel leakage at the fuel pump or its connections is a fire hazard and should be corrected. Make sure proper ventilation exists whenever servicing fuel system components.*

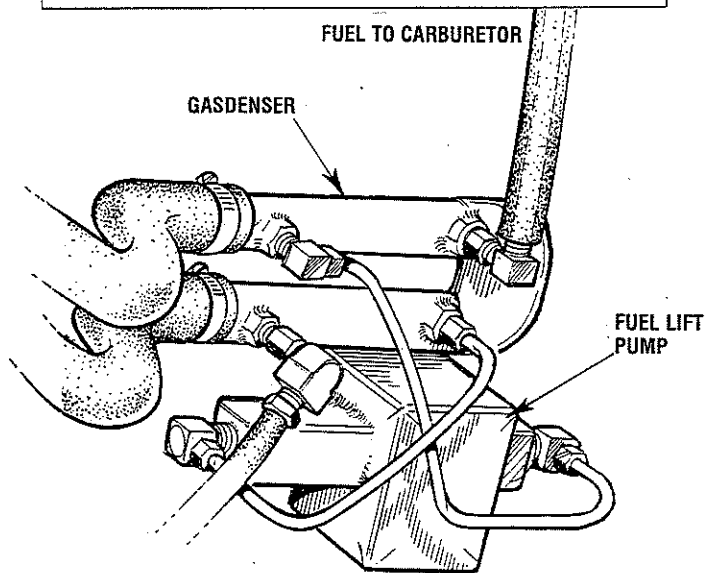

GASDENSER

The gasdenser cools the fuel to prevent vapor lock, there is no maintenance required except making certain the fuel fittings are tight and secure.

GASOLINE/WATER SEPARATOR AND FILTER

A primary fuel filter of the water separating type must be installed between the fuel tank and the engine to remove water and other contaminants from the fuel before they can be carried to the fuel system on the engine.

Most installers include a type of filter/water separator with the generator installation package as they are well aware of the problems that contaminants in the fuel can cause.

These gasoline filters must have *metal* bowls (not "see-through") to meet U.S. Coast Guard requirements. The metal bowls have drain valves to use when checking for water and impurities.

**GASOLINE
WATER SEPARATOR
AND FILTER**
OWNER/BUILDER INSTALLED



CARBURETOR ADJUSTMENTS

CARBURETOR

The carburetor is a single barrel, down-draft type with a cleanable metal screen air intake filter/spark arrester.

The choke is operated by a 12 VDC solenoid. This choke solenoid is activated when the ON switch is depressed and stays activated. After the engine starts (cold start) the choke solenoid circuit is kept activated by the oil temperature switch. Once oil temperature reaches 120°F the switch opens and the choke solenoid deactivates, opening the choke. This helps prevent stalling on a cold start.

Air Screen/Flame Arrester

The air screen/flame arrester can easily be removed by releasing the hold-down clamp. Clean after the first 50 hours of operation, every 100 hours from then on. Clean the air screen in kerosene.

Carburetor Filter Screen

Clean this filter element after the first 50 hours of operation, then clean and inspect every 250 operating hours. Replace the screen if necessary.

Tighten the plug and make certain there are no leaks.

Idle Mixture Jet

Adjustment is performed with the generator operating. Screw the jet slowly in until it seats, then back it out 1-1/2 to 2 turns.

Note: An idle mixture jet adjusted too far off its seat can induce a sooty exhaust discharge at engine start-up and shut-down.

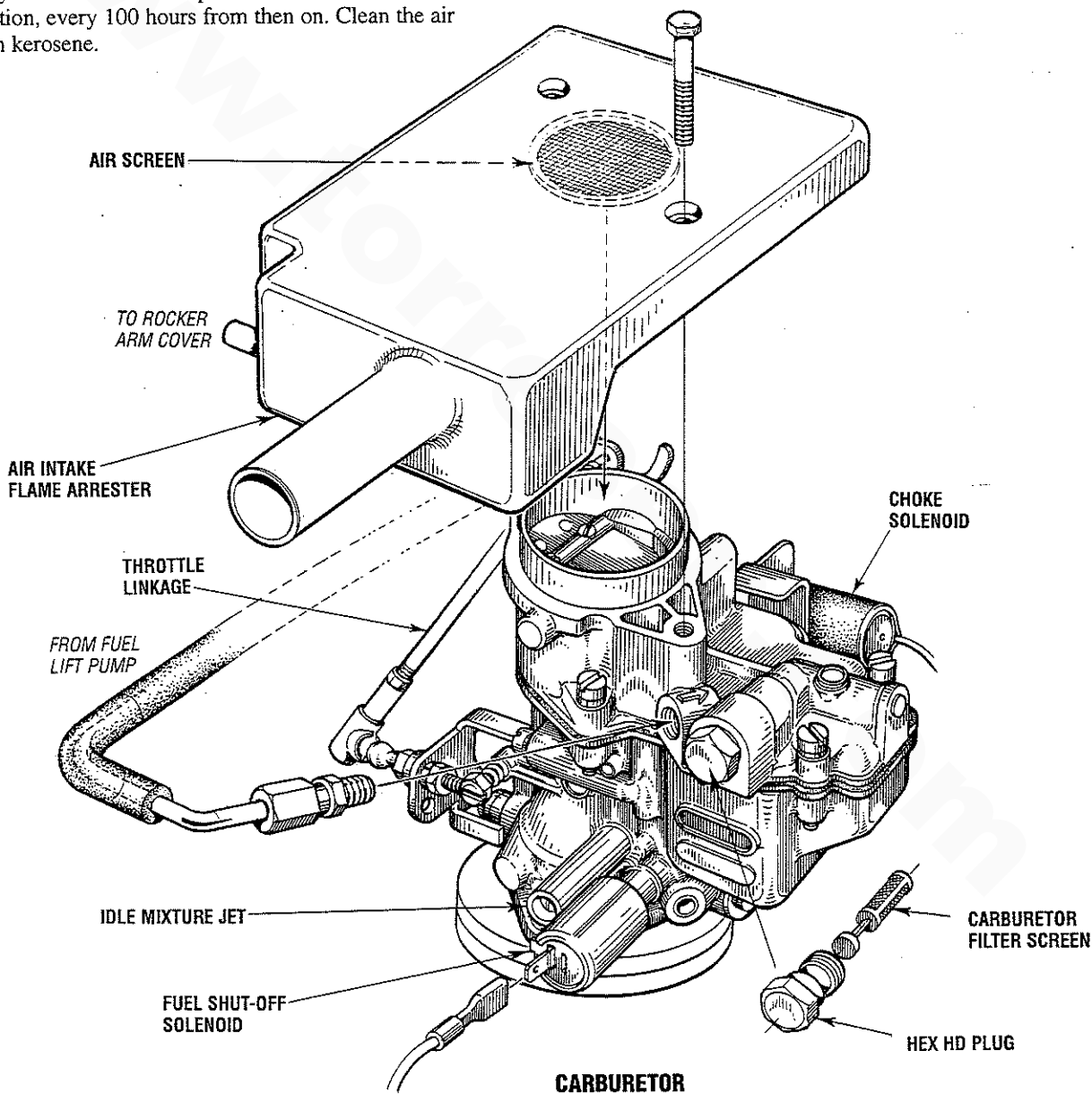

ENGINE LUBRICATING OIL

DESCRIPTION

Use a heavy duty engine oil with an API classification of SJ. Change the engine oil after an initial 50 hours of break-in operation and every 100 hours of operation thereafter. For recommended oil viscosity see the following chart:

Operating Temperature	Oil Viscosity
Above 68° F (20° C)	SAE 30, 10W-30 or 15W-40
41° - 68° F (5°-20° C)	SAE 20 or 10W-30
Below 41° F (5° C)	SAE 10W-30

CAUTION: Do not allow two or more brands of engine oil to mix. Each brand contains its own additives; additives of different brands could react in the mixture to produce properties harmful to your engine.

CHANGING THE ENGINE OIL

The engine oil should be warm. Remove the oil drain hose from its attachment bracket and lower it into a container and allow the oil to drain, or attach a pump to the end of the drain hose and pump the old oil out. Make sure the oil drain hose is properly secured in its holder after all of the old oil has been drained.

Always observe the old oil as it is removed. A yellow/gray emulsion indicates the presence of water in the oil. Although this condition is rare, it does require prompt attention to prevent serious damage. Call a competent mechanic if water is present in the oil. Raw water present in the oil can be the result of a fault in the exhaust system attached to the engine and/or a siphoning through the raw water cooling circuit into the exhaust, filling into the engine.

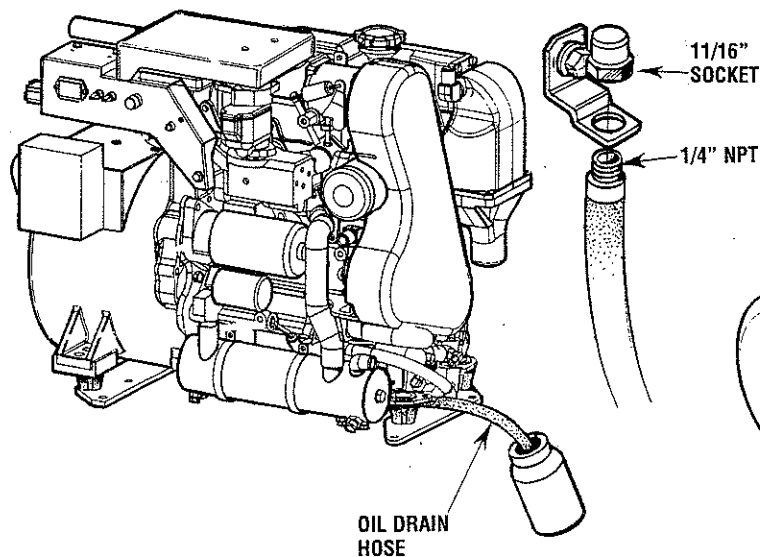

WARNING: Used engine oil contains harmful contaminants. Avoid prolonged skin contact. Clean skin and nails thoroughly using soap and water. Launder or discard clothing or rags containing used oil. Discard used oil properly.

Replacing the Oil Filter

When removing the used oil filter, you may find it helpful to punch a hole in the upper and lower portion of the old filter to drain the oil into a container before removing it. This helps to lessen spillage. An automotive filter wrench should be helpful in removing the old oil filter. Place some paper towels and a plastic bag around the filter when unscrewing it to catch any oil that's in the filter. Inspect the old oil filter as it is removed to make sure that the rubber sealing gasket comes off with the old oil filter. If this rubber sealing gasket remains sealed against the oil filter adapter, gently remove it. When installing the new oil filter element, wipe the filter gasket's sealing surface on the oil filter adapter free of oil and apply a thin coat of clean engine oil to the rubber sealing gasket on the oil filter. Screw the filter onto the threaded oil filter stub, and tighten the filter firmly by hand.

NOTE: Use genuine WESTERBEKE oil filters. Generic filters are not recommended.

REFILLING THE OIL SUMP

Add fresh oil through the valve cover. After refilling the oil, run the engine for a few moments while checking the engine's oil pressure. Make sure there is no leakage around the new oil filter or from the oil drain system, and then stop the engine. Then check the quantity of oil with the lube oil dipstick. Fill to, but not over, the FULL mark.

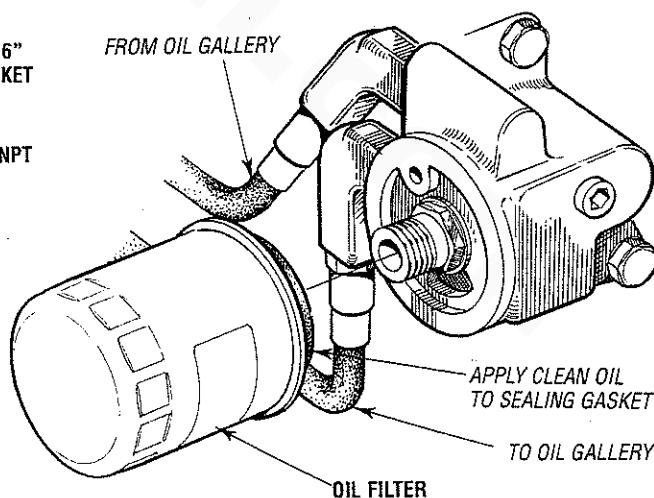

OIL PRESSURE

NOTE: WESTERBEKE recommends that the following engine adjustments be performed by a competent engine mechanic. The information below is provided to assist the mechanic.

DESCRIPTION

The lubricating system is a pressure feeding system using an oil pump. The engine oil is drawn from the oil sump by the oil pump, which drives the oil, under pressure, through the oil filter, oil cooler and various lubricating points in the engine. The oil then returns to the oil sump to repeat the continuous cycle. When the oil pressure exceeds the specified pressure, the oil pushes open the relief valve in the oil pump and returns to the oil sump, keeping the oil pressure within its specified range.

TESTING OIL PRESSURE

To test the oil pressure, remove the hex head plug from the oil manifold and install a mechanical oil pressure gauge in its place. After warming up the engine, set the engine speed at 1800 rpm and read the oil pressure gauge.

Oil Pressure Between 30 and 40 psi at 1800 rpm.

Note: A newly started (cold) engine may have an oil pressure up to 70 or 80 psi. A warmed engine can have an oil pressure as low as 30 psi. Oil pressure will vary depending on the load placed on the generator.

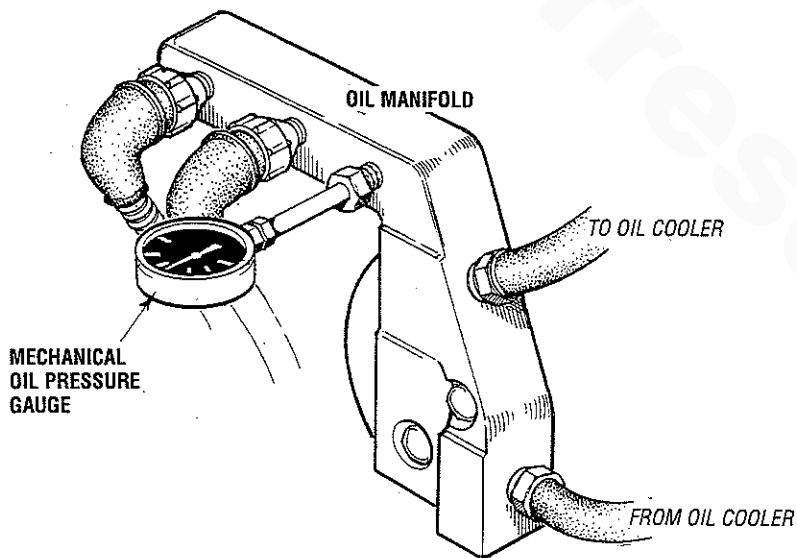

LOW OIL PRESSURE

The specified safe minimum oil pressure is 4.3 + 1.4 psi (0.3 + 0.1 kg/cm²). A gradual loss of oil pressure usually indicates worn bearings. For additional information on low oil pressure readings, see the *ENGINE TROUBLESHOOTING* chart.

OIL PRESSURE SWITCH

The generator is fitted with an oil pressure sensor and a shutdown switch. Should the engine's oil pressure drop below the safe minimum, the switch will shut the engine down to prevent damage by interrupting the DC voltage to the K2 run relay.

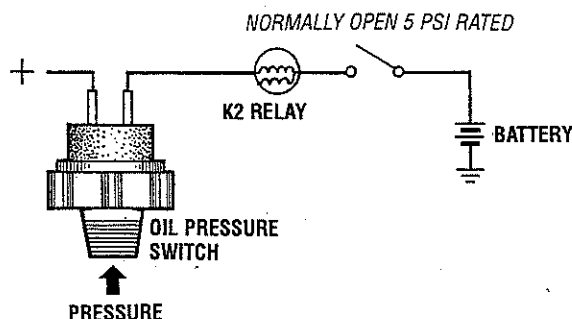

REMOTE OIL FILTER (OPTIONAL)

INSTALLATION

This popular accessory is used to relocate the engine's oil filter from the engine to a more convenient location such as an engine room bulkhead.

NOTE: Refer to *ENGINE OIL CHANGE* in this manual for instructions on removing the oil filter.

To install, simply remove the engine oil filter and thread on WESTERBEKE's remote oil filter kit as shown. Always install this kit with the oil filter facing down as illustrated.

Contact your WESTERBEKE dealer for more information.

NOTE: Westerbeke is not responsible for engine failure due to incorrect installation of the Remote Oil Filter.

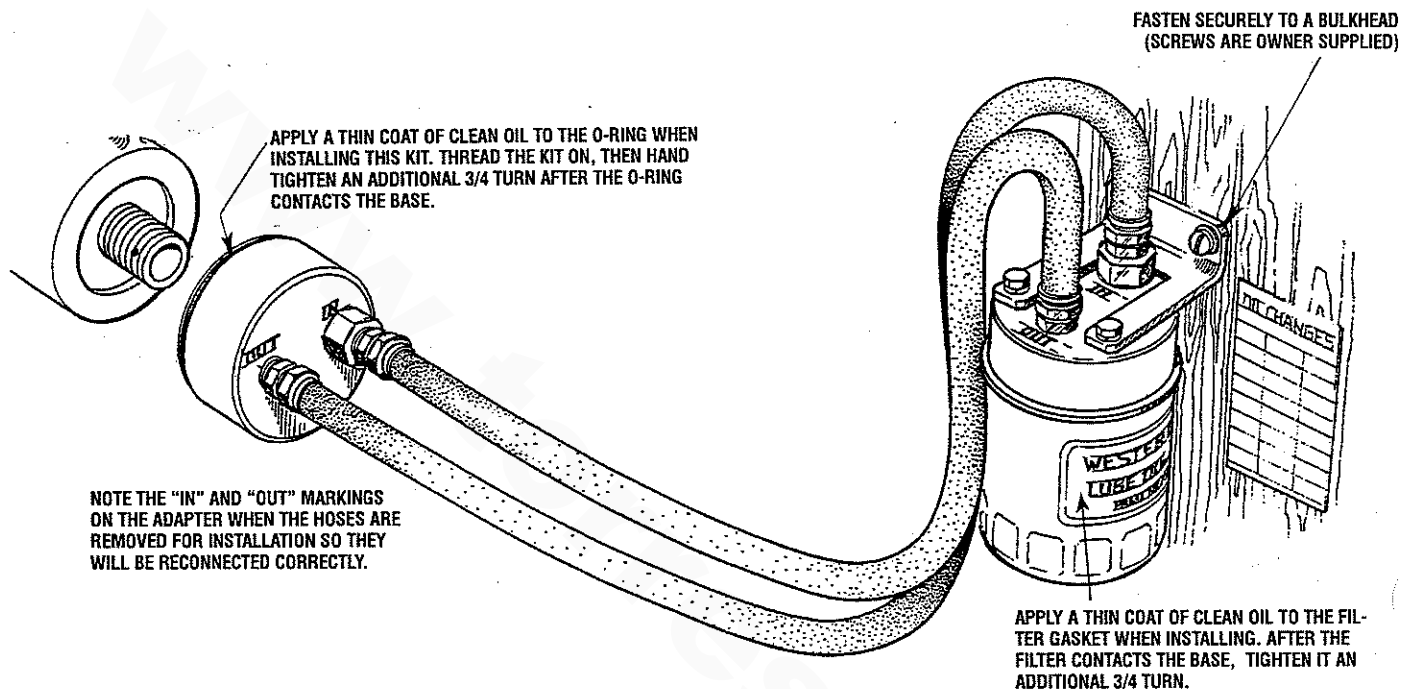

4.5KW / 7.0KW BCGB GENERATOR

WIRING DIAGRAM #43864

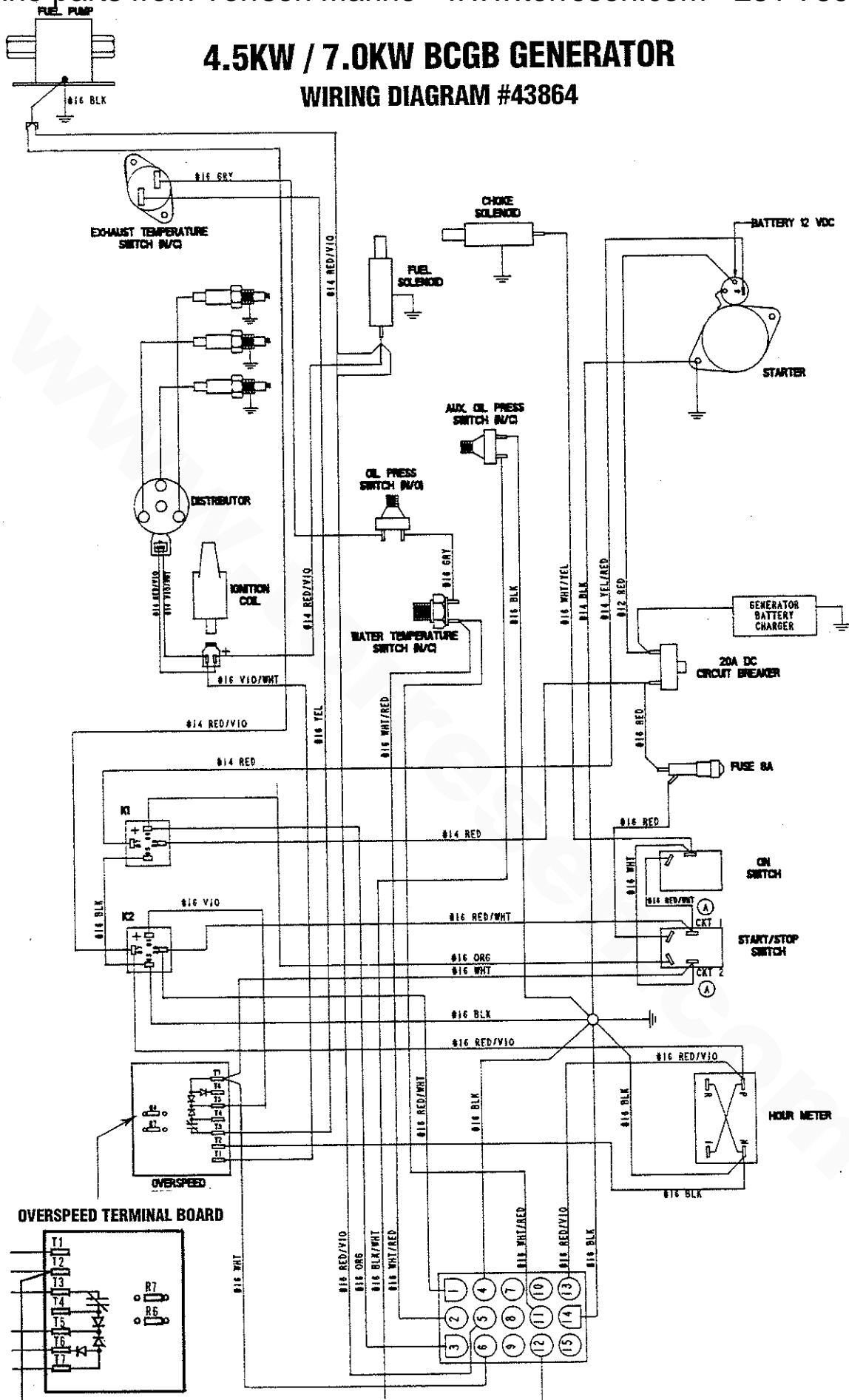

4.5KW / 7.0KW BCGB GENERATOR WIRING SCHEMATIC #43864

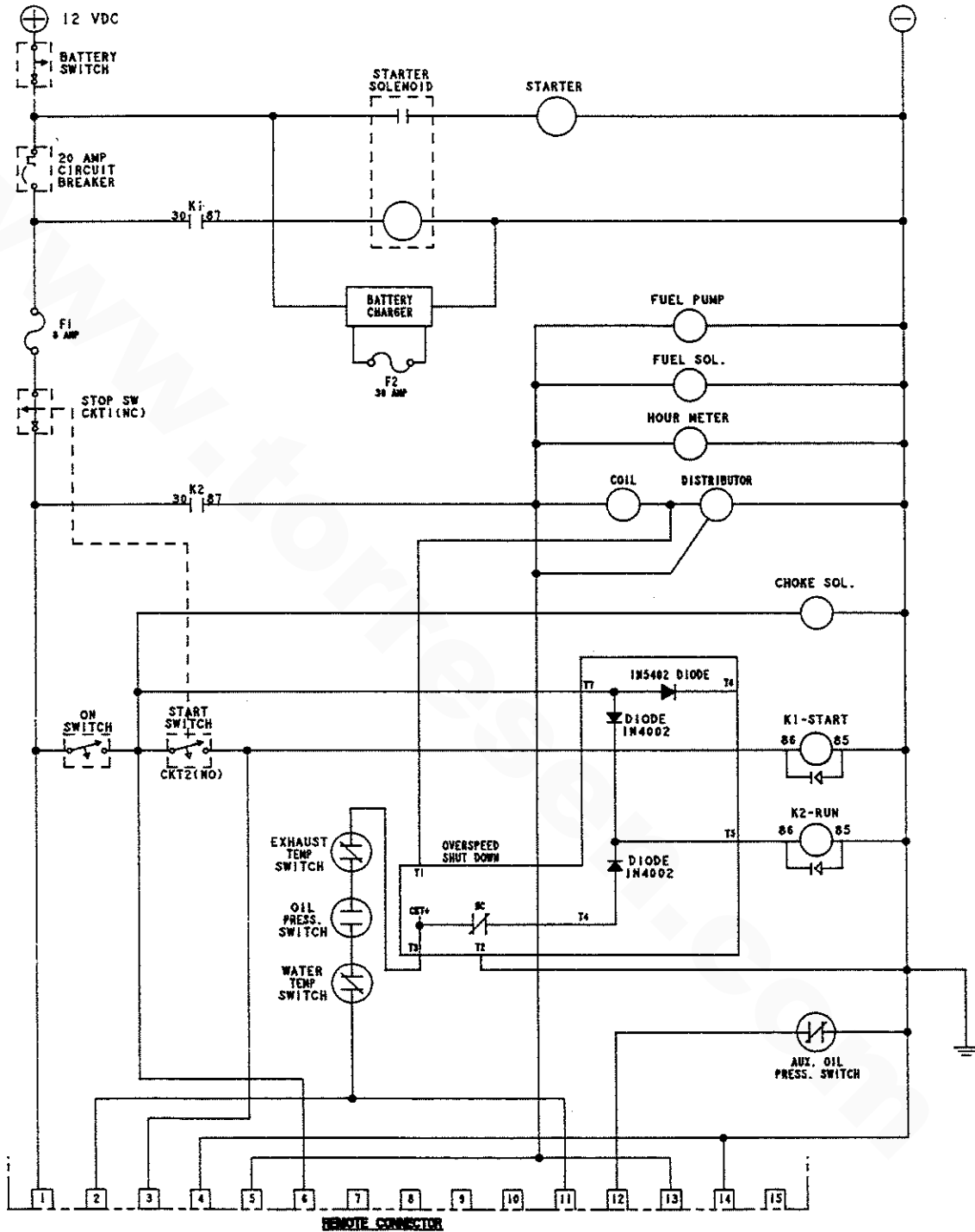

REMOTE PANEL WIRING SCHEMATIC #043912

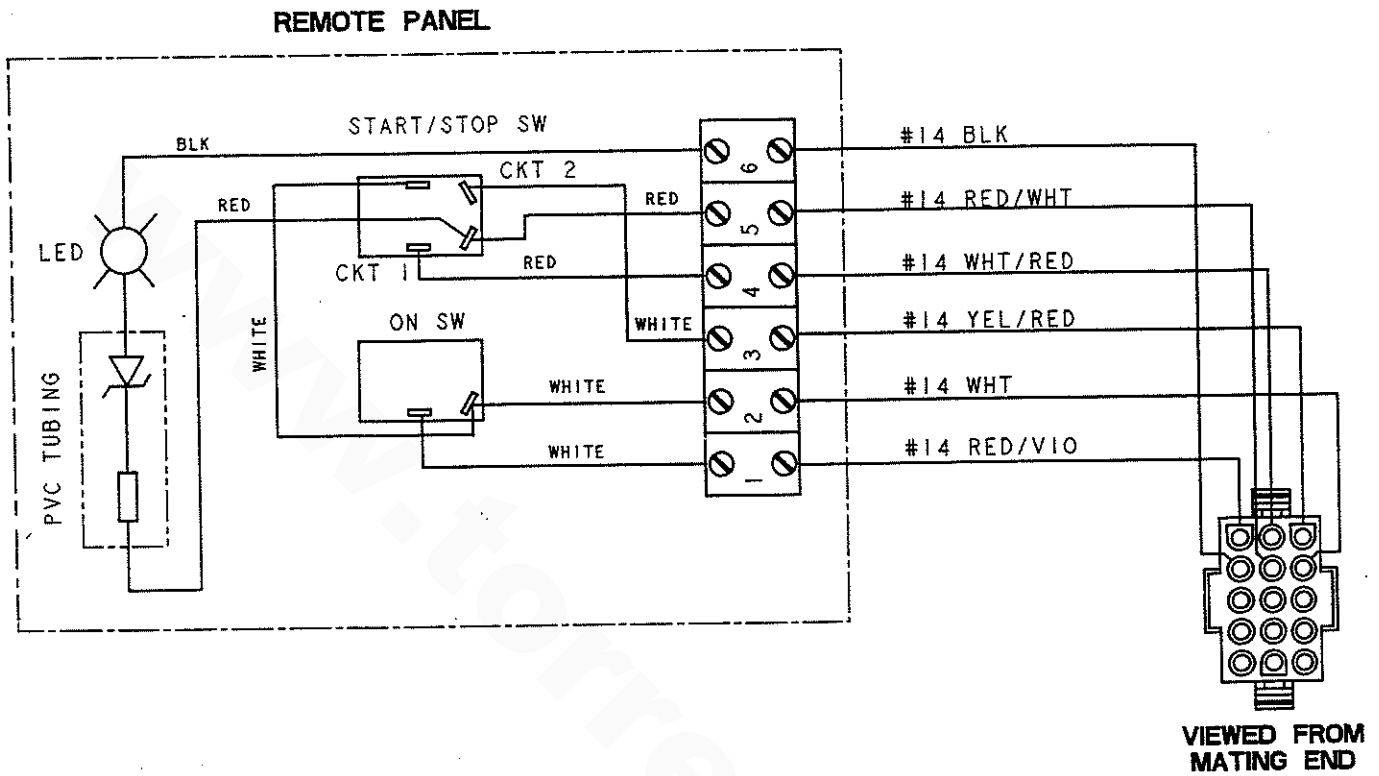

ENGINE ADJUSTMENTS

NOTE: WESTERBEKE recommends that the following engine adjustments be performed by a competent engine mechanic. The information below is provided to assist the mechanic.

ENGINE SPEED (HERTZ) ADJUSTMENT

Governor

The belt-driven, mechanically operated governor maintains the engine's rpm under various load conditions. Engine speed determines the hertz and voltage output of the generator.

Governor Adjustments

Operate the generator to bring the unit up to operating temperature before adjusting the governor.

NOTE: If the governor is severely out of adjustment, manually adjust the linkage at no-load to obtain a safe output voltage before proceeding with the adjustment.

There are three adjusting points on the governor (see illustration).

1. **Increase/Decrease Speed Adjustment.** This adjusting bolt sets the no-load speed of the engine. (The linkage arm between the governor arm and throttle lever should be adjusted to hold the throttle full open when the engine is not running.) Make sure this linkage moves freely and that the ball joint connectors are properly lubricated. Use graphite lube for this purpose. Disconnect the ball joint and apply graphite lube to the inside of the joint.

2. **Hunting/Regulation Adjustment.** If the variation in engine speed between no-load and full-load is too great, adjust this eye bolt to draw the spring closer to the lever hub. The increase/decrease speed bolt may need to be adjusted as well.

If the governor surges under load, adjust this eye bolt to move the spring away from the lever hub (check speed adjustment).

3. **Bumper Screw Adjustment.** This screw is used to remove a no-load surge ONLY. NEVER turn the bumper screw into the governor so far that it increases the no-load speed.

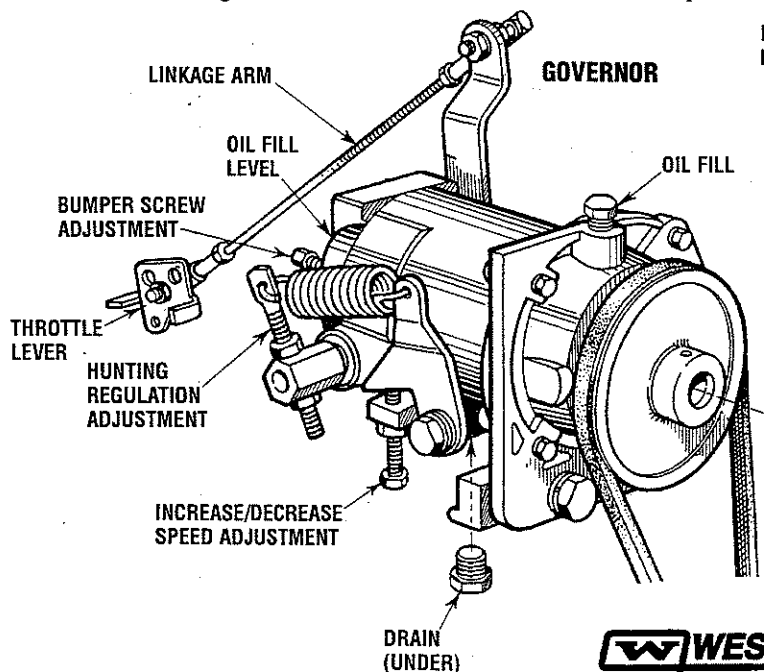

Governor Maintenance

1. Periodically lubricate the linkage arm attaching points at the governor arm and throttle lever. Use a graphite lubricant or equivalent.

NOTE: Free movement of this linkage arm is important for proper governor/throttle operation.

2. Governor oil capacity – 3 ounces 10/30 engine oil.

NOTE: Do not overfill the governor.

3. Change the governor oil every 250 hours of operation.

To change the oil, remove the governor from the engine, remove the oil fill and the fill level plug, and drain all the oil. Reinstall on the engine and fill with 3 ounces of 10/30 engine oil. Replace the plugs.

4. Periodically adjust the governor belt tension (see *DRIVE BELTS ADJUSTMENT*). Since belts stretch slightly, this stretching will, to some degree, affect the governor's action.

TORQUING THE CYLINDER HEAD BOLTS

After the initial break-in period (approximately 50 hours), the cylinder head bolts should be re-torqued.

Tighten the cylinder head bolts according to the sequence shown. Make sure the engine is cold when this is done, and loosen one head bolt one-half turn and then tighten it between 43 - 51 lb-ft (60 - 70 Nm). Then proceed to the next head bolt in the sequence. Tighten the RS (rocker cover stud) securely.

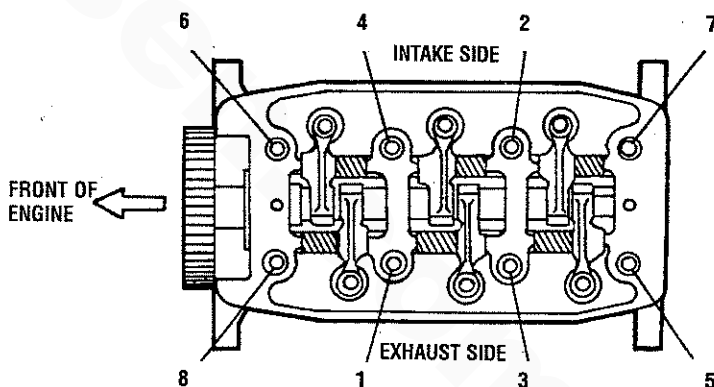

ENGINE ADJUSTMENTS

SPARK PLUGS

The spark plugs should be cleaned and regapped after the first 50 hour break-in period, then inspected every 250 hours thereafter and replaced as needed.

WARNING: Do not remove the spark plugs while the engine is hot. Allow the engine to cool before removing them.

Spark plug gap: 0.031 +/- 0.0002 in. (0.8 - 0.05 mm).

Spark plug torque: 10 - 15 lb-ft (1.5 - 2.31 kg-m).

NOTE: Loctite Anti-Seize applied to the threaded portion of the spark plugs will retard corrosion, making future removal of the spark plugs easier.

INSPECTING THE SPARK PLUGS

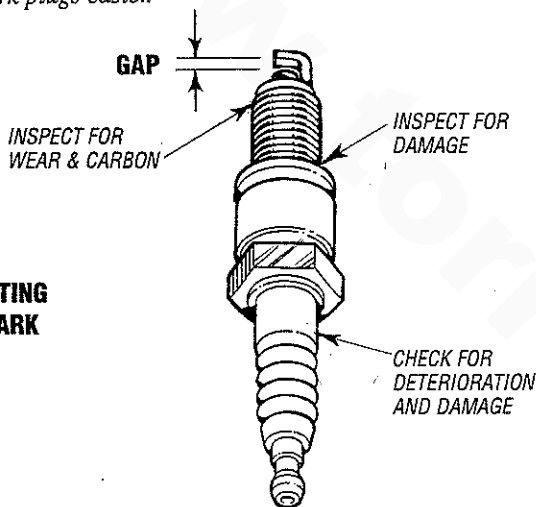

DRIVE BELT ADJUSTMENT

The drive belt must be properly tensioned. Excessive drive belt tension can cause rapid wear of the belt and reduce the service life of the fresh water pump's bearing. A slack belt or the presence of oil on the belt can cause belt slipping, resulting in high operating temperatures.

The BCGB generator has two drive belts, one drives the governor and alternator and the other drives the raw water pump. The tension adjustment procedure for both belts is as follows:

1. Remove the belt guard.
2. To adjust the governor drive belt, loosen the two governor mounting bolts.

To adjust the raw water pump/fresh water pump drive belt, loosen the two raw water pump mounting bolts.

3. With the belt(s) loose, inspect for wear, cracks and frayed edges, and replace if necessary.
4. To loosen or tighten the governor drive belt, slide the governor in or out as required, then retighten its mounting bolts.

To loosen or tighten the raw water pump/fresh water pump drive belt, slide the raw water pump in or out as required, then retighten its mounting bolts.

5. The drive belts are properly adjusted if it can be deflected no less than 3/8 inch (10mm) and no more than 1/2 inch (12mm) as the belt is depressed with the thumb at the midpoint between the two pulleys on the longest span of the belt.

NOTE: Maintain a 22 lb pressure to the belt's outer face for proper belt operation. Spare belts should always be carried on board.

WARNING: Never attempt to check or adjust a drive belt's tension while the engine is in operation.

6. Operate the generator for about 5 minutes, then shut down the generator and recheck the belt(s) tension.
7. Replace the belt guard.

ENGINE ADJUSTMENTS

NOTE: WESTERBEKE recommends that the following engine adjustments be performed by a competent engine mechanic. The information below is provided to assist the mechanic.

VALVE CLEARANCE ADJUSTMENT

NOTE: Retorque the cylinder head bolts before adjusting the engine's valves (see **TORQUING THE CYLINDER HEAD BOLTS**).

1. Remove the rocker cover and gasket.
2. Rotate the crankshaft in the normal direction of rotation, placing the No. 1 piston at the top of its compression stroke with the exhaust and intake valves completely closed. Adjust the intake and exhaust valves for No. 1 cylinder, the exhaust valve for No. 2 cylinder, and the intake valve for No. 3 cylinder (see chart).
3. Rotate the crankshaft 180° in its normal direction of rotation. Locate the piston in No. 1 cylinder at the top of its exhaust stroke. Adjust the intake valve for No. 2 cylinder and the exhaust valve for No. 3 cylinder (see chart).

CRANK ANGLE		CYLINDER #		
		1	2	3
When No. 1 piston is set at top of compression stroke	IN	●		●
	EX	●	●	
When No. 1 piston is positioned at top of exhaust stroke	IN		●	
	EX			●

4. Replace the rocker cover along with a new rocker cover gasket..

Rocker cover torque: 2.9-5.1 lb-ft (4 - 7 Nm)

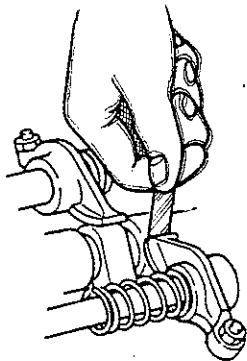

VALVE CLEARANCE

Valve Clearance: Intake 0.20mm (.008 inches)
Exhaust 0.30mm (.0012 inches)

IGNITION TIMING

1. Attach a timing light to the #1 spark plug and mark the front timing pointer to indicate 15°. Locate the timing mark on the crankshaft pulley and mark it with white chalk or a crayon.
2. Start the engine and warm it up to its normal operating temperature. Make sure the generator is operating *without a load on it*.
3. Using the timing light, align the timing mark in the front crankshaft pulley so it is just slightly before the first timing pointer. Do this by loosening and slowly rotating the distributor body. Use the following timing specifications:

Timing Specifications: 15° ± .5° BTDC at 1800 rpm
(no load on generator)

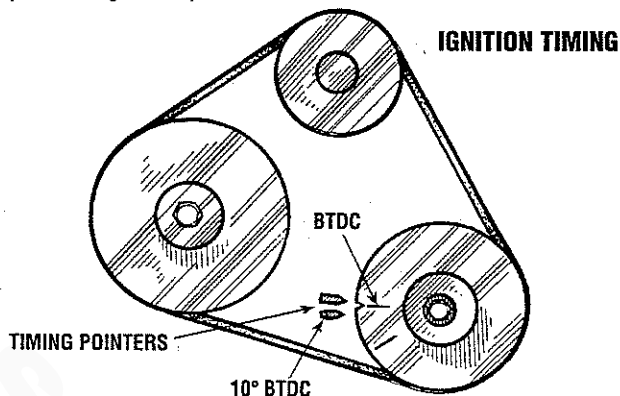

CHOKE SOLENOID

The choke solenoid is a 12 volt DC operated unit that functions to close the choke plate in the carburetor when the ON switch is depressed during engine start-up.

The choke solenoid de-energises once the engine starts and the ON switch is released. Some unstable running may be present when the engine starts cold but should smooth out as the engine reaches operating temperature.

Keep this solenoid dry and periodically lubricate the linkage between the solenoid and the choke lever.

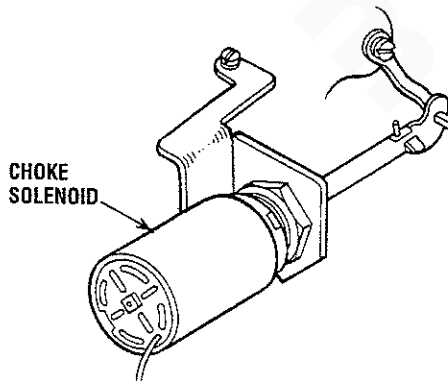

ENGINE ADJUSTMENTS

NOTE: WESTERBEKE recommends that the following engine adjustments be performed by a competent engine mechanic. The information below is provided to assist the mechanic.

TIMING BELT INSPECTION AND REPLACEMENT

Timing Belt Removal

CAUTION: Water or oil on the timing belt severely reduces the service life of the belt. Keep the timing belt sprocket and tensioner free of oil and grease. These parts should never be cleaned. Replace if seriously contaminated with dirt or oil. If oil is evident on these parts, check the front case, oil pump oil seals, and camshaft oil seals for a possible oil leak.

1. Turn the crankshaft clockwise to align the timing mark on the camshaft sprocket and timing belt rear cover.

NOTE: always turn the crankshaft clockwise.

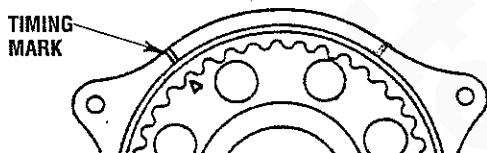

2. Remove the plug on the left surface of the cylinder block and insert a rod with a diameter of 8mm (0.31 in.) to lock the counterbalance shaft.

NOTE: Be sure to use an inserting rod with a diameter of 8mm (0.31 in.).

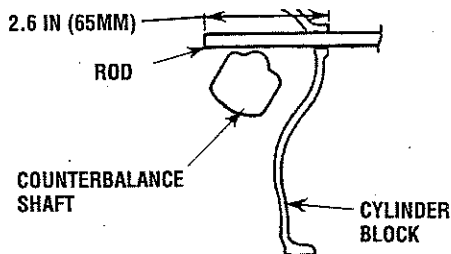

3. Loosen the timing belt tensioner nut.
4. Move the timing belt tensioner toward the water pump, and temporarily tighten the nut to hold the tensioner in that position.

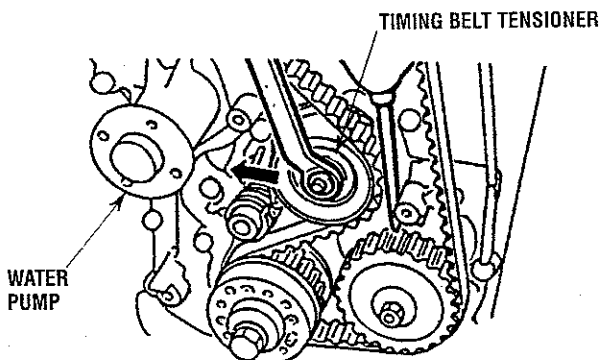

5. Remove the timing belt.

NOTE: If the timing belt is to be reused, draw an arrow on the belt back to indicate the direction of rotation (clockwise).

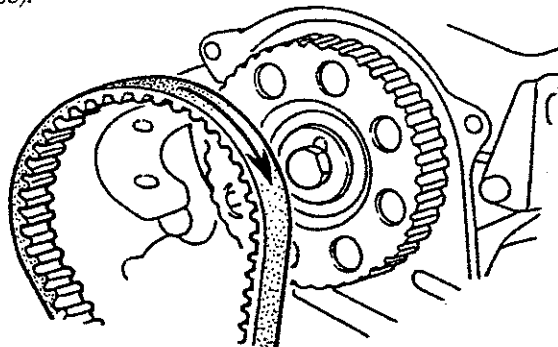

Camshaft Sprocket Removal

1. Remove the bolt without turning the camshaft.

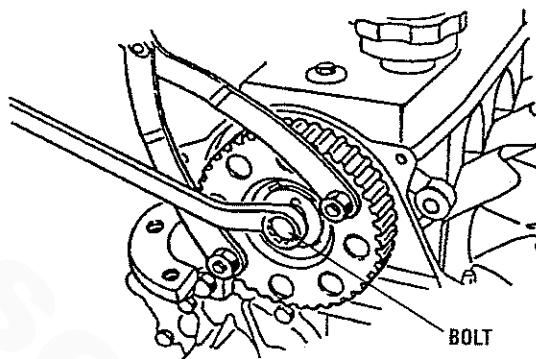

Oil Pump Sprocket Flange Nut Removal.

1. Remove the plug from the left side of the cylinder block.
2. Insert an 8 mm (0.31 in.) diameter round bar to lock the counterbalance shaft.
3. Remove the nut.

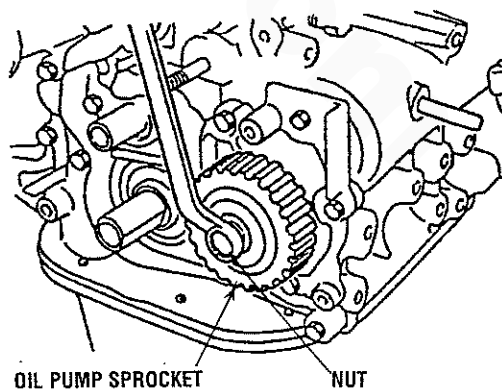

ENGINE ADJUSTMENTS

NOTE: WESTERBEKE recommends that the following engine adjustments be performed by a competent engine mechanic. The information below is provided to assist the mechanic.

Crankshaft Bolt Removal

1. Lock the crankshaft in position.
NOTE: Do not turn the crankshaft.

2. Remove the crankshaft bolt.

Timing Belt Inspection

Replace the belt if any of the following conditions exist:

1. Hardening of back rubber-back side is glossy, without resilience, and leaves no indent when pressed with fingernail.
2. Cracks on rubber back.
3. Cracks or peeling of canvas.
4. Cracks on tooth bottom.
5. Cracks on belt.
6. Abnormal wear of belt sides. The sides are normal if they are sharp as if cut by a knife.
7. Abnormal wear on teeth.
8. Tooth missing and canvas fiber exposed.

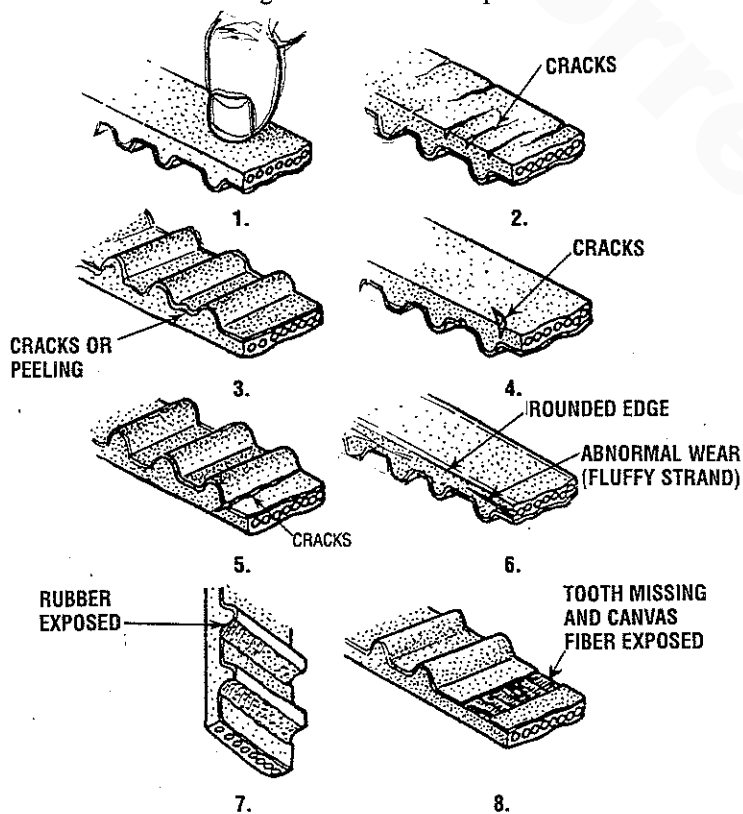

Tensioner Inspection

1. Replace the tensioner if the pulley binds, rattles or is noisy when turned.

Flange Installation

1. Mount the flange so that its side shown by the heavy arrow in the illustration faces toward the sprocket.

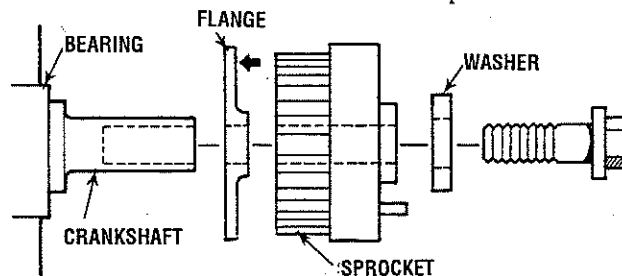

Crankshaft Bolt Installation

1. Lock the crankshaft.
NOTE: Do not turn the crankshaft.
2. Tighten the crankshaft bolt to the specified torque.

Oil Pump Sprocket Flange Nut Installation

1. Insert a round bar into the plug hole in the left side of the cylinder block to keep the counterbalance shaft from turning.
2. Install the oil pump sprocket.
3. Tighten the nut to the specified torque.

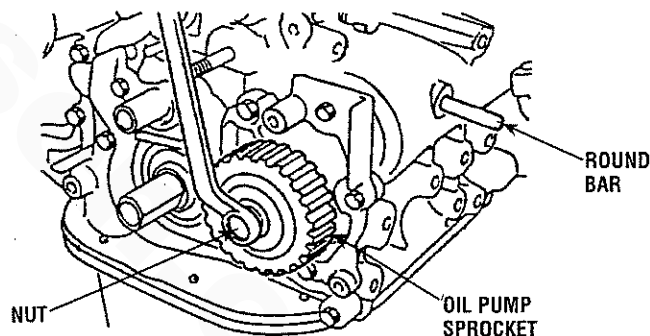

Camshaft Sprocket Bolt Installation

1. Tighten the bolt to the specified torque.
Bearing Cap Bolt Torque 36 40 ftlbs (50 -55 Nm)

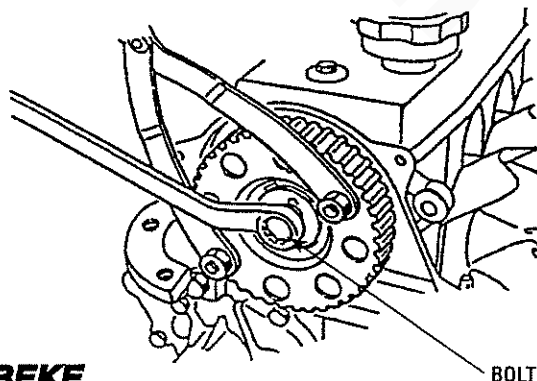

ENGINE ADJUSTMENTS

NOTE: WESTERBEKE recommends that the following engine adjustments be performed by a competent engine mechanic. The information below is provided to assist the mechanic.

Tensioner Spring/Timing Tensioner Installation

1. Install the tensioner spring and timing belt tensioner.
2. Hook the tensioner spring onto the bend of the timing belt tensioner bracket and the stopper pin on the cylinder block.
3. Move the timing belt tensioner as close as possible to the water pump; temporarily tighten the tensioner nut.

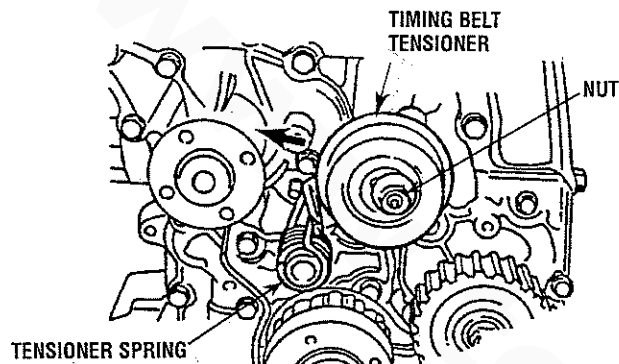

Timing Belt Installation

1. Align the triangular marking on the camshaft sprocket with a marking on the timing belt rear cover.
2. Align the notch in the crankshaft sprocket flange with the marking on the front case.
3. Align the triangular marking on the oil pump sprocket with the marking on the front case, and then insert a 65 mm (2.56 in.) or longer, 8 mm (0.31 in.) diameter round bar into the plug hole in the left side of the cylinder block.

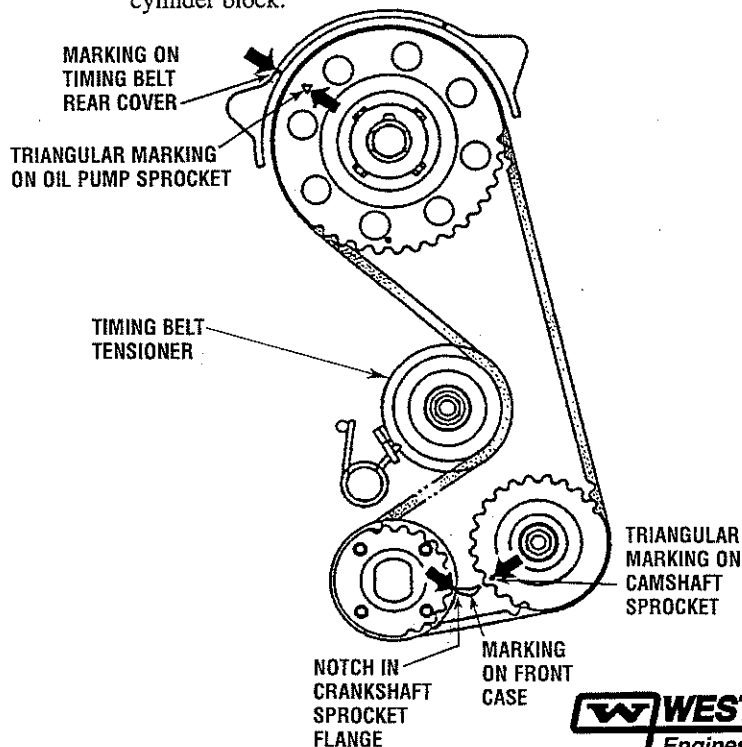

At this time, check that the moveable range of teeth on the oil pump sprocket is according to specifications.

Standard value: 4 to 5 teeth in forward direction.
1 to 2 teeth in reverse direction.

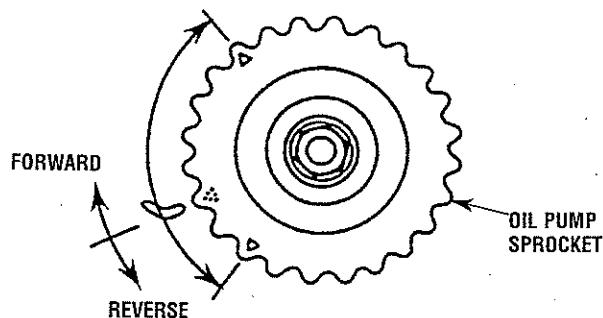

4. If the movable range of the oil pump sprocket exceeds the specified range, correct as follows:
 - a. Pull out the round bar from the plug hole in the left side of the cylinder block.
 - b. Turn the oil pump sprocket one turn at a time until the round bar can again be inserted.
 - c. Check that the movable range of the oil pump sprocket is in the specified value.
5. Set the timing belt over the crankshaft sprocket and then over the oil pump sprocket and camshaft sprocket, in that order.

NOTE: Ensure that the tension side of the timing belt is not slack. Keep the round bar inserted until the timing belt has been placed. After this step, be sure to remove the round bar.

6. Apply counterclockwise force to the camshaft sprocket to make the belt taut on the tension side, and make sure that all timing marks are lined up.

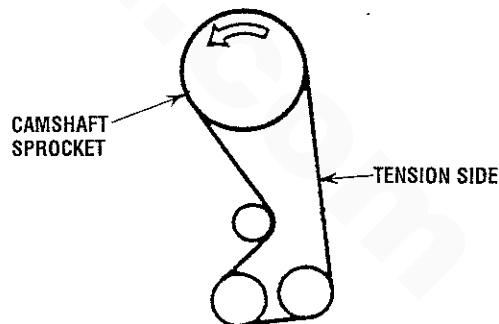

7. Loosen the temporarily tightened tensioner nut on the water pump side 1 or 2 turns, and tension the belt making use of spring force.



ENGINE ADJUSTMENTS

NOTE: WESTERBEKE recommends that the following engine adjustments be performed by a competent engine mechanic. The information below is provided to assist the mechanic.

- Turn the crankshaft *clockwise* by nine camshaft sprocket teeth (817) to align the timing mark on the camshaft sprocket with the tensioner set mark on the timing belt rear cover.

CAUTION: This operation is performed to give a proper tension to the timing belt, so do not turn the crankshaft counterclockwise and push the belt to check the tension.

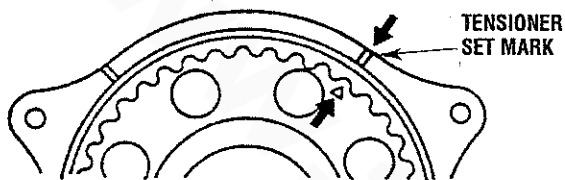

- Make sure that the timing belt teeth are engaged with the camshaft sprocket teeth along the portion of the sprocket shown by the curved arrow in the illustration below. Then tighten the tensioner nut.
- Pull the timing belt in the center of the tension side toward the sealing gasket line for the belt cover, as illustrated. Make sure that the clearance between the back of the belt and the sealing line is the standard value.

Standard Value: 12mm (0.47in.)

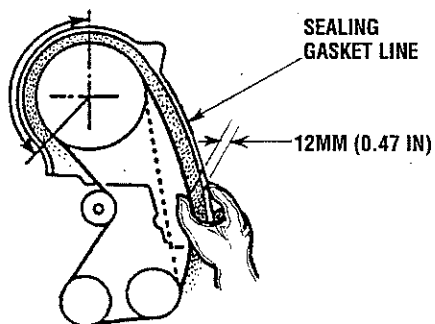

- Pull out a rod from the plug hole on the left surface of the cylinder block and apply the specified sealant. Then tighten the plug to the specified torque.
Specified sealant value: 3M ATD Part No. 8660 or equivalent
Tightening torque: 15-22 Nm (11-16 ft.lbs.)

ENGINE COMPRESSION TEST

- To check the engine's compression pressure, warm up the engine then shut it down.
- Remove the three spark plug caps and remove the three spark plugs.
- Install a compression adapter and gauge in the spark plug hole.
- Close off the raw water intake seacock.
- Crank the engine with the start motor and unplug the ignition coil and allow the compression gauge to reach a maximum reading and record.
- Measure the compression pressure for all the cylinders. Ensure that compression pressure differential for each cylinder is within the specified unit.
Compression pressure should not differ by more than 14 psi (100 Kpa).
- If a cylinder's compression or pressure differential is below the limit, add a small amount of engine oil through the spark plug hole and repeat steps 4 and 5.
 - If additional of oil causes an increase of pressure, the piston ring and/or cylinder wall may be worn or damaged.
 - If additional oil does not increase compression pressure suspect poor valve contact, valve seizure, or valve wear.
- Reinstall three plugs and ignition wires.
- Open the raw water thru seacock.

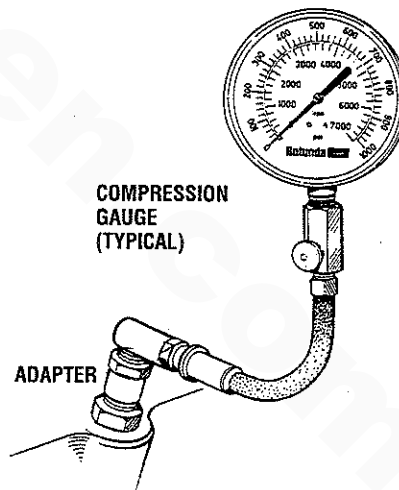

COMPONENT TESTING

NOTE: WESTERBEKE recommends that the following engine testing adjustments be performed by a competent technician.

GENERAL

All DC voltage measurements are made to the engine battery negative ground point unless specified otherwise. In making test measurements, make sure that a good ground for the meter is established, preferably the point where the negative battery is connected to the engine. Battery positive voltage is indicated as B+ and should measure no less than 11.5 volts.

AC voltage measurements should be made with a true RMS AC meter to insure measurement accuracy.

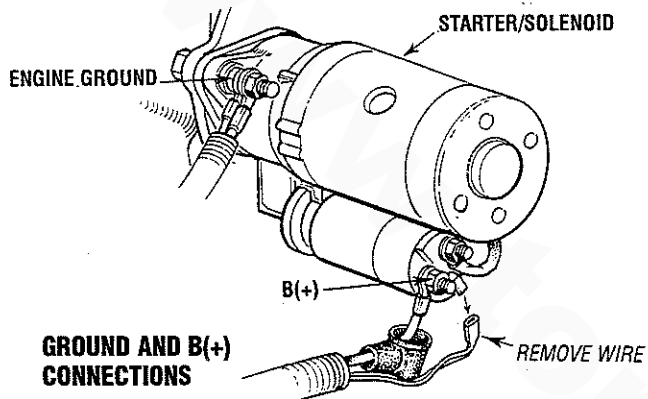

**GROUND AND B(+)
CONNECTIONS**

RELAYS

The relays used in the control system have coils which are polarized by the fact that they have internal free wheeling suppression diodes across them. Relay coil terminal 86 must be maintained (+), terminal 85(-). The relay coil is rated 12V DC, and the coil resistance is typically 85 ohms. With B+ on terminal 86, direct grounding of terminal 85 is permissible for testing purposes.

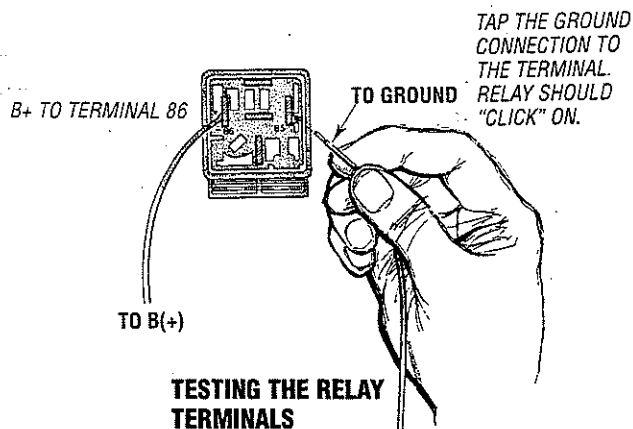
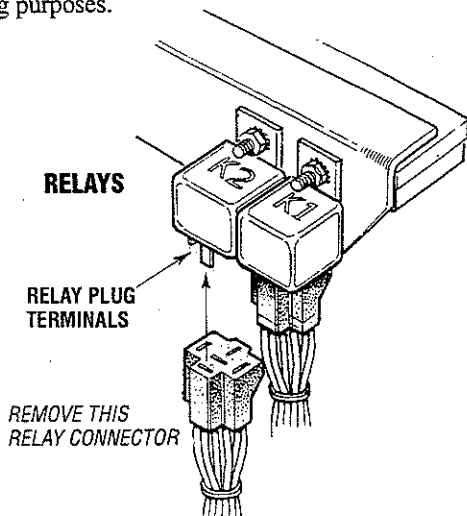

**TESTING THE RELAY
TERMINALS**

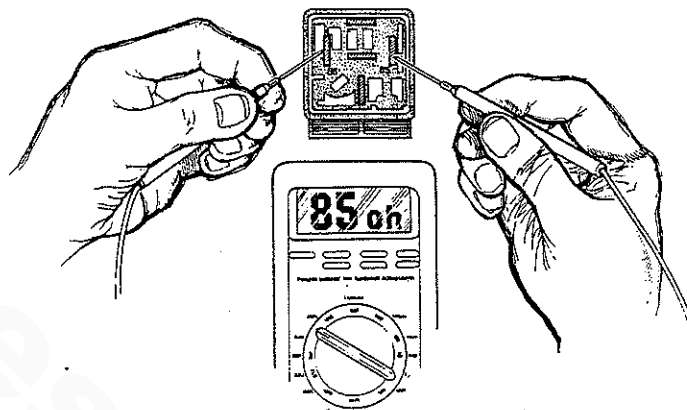

TESTING COIL RESISTANCE

ENGINE TROUBLESHOOTING

The following troubleshooting tables are based upon certain engine problem indicators and the most likely causes of the problems.

When troubleshooting indicates an electrical problem, see the ELECTRICAL SYSTEM WIRING DIAGRAM, as these may reveal other possible causes of the problem which are not listed below.

NOTE: The engines control system (electrical system) is protected by a 20 Ampere manual reset circuit breaker located on the control panel.

PROBLEM	PROBABLE CAUSE
Engine does not crank.	<ol style="list-style-type: none"> 1. Voltage drop at starter solenoid terminal. 2. Engine 20A circuit breaker has tripped. 3. Battery is low or dead. 4. Loose battery connections. 5. Faulty wire connection. 6. Faulty start switch. 7. Faulty start relay (K1). 8. Faulty starter solenoid 9. Raw water filled cylinders. 10. Filters are clogged by contaminated fuel. 11. Voltage drop at (+) at overspeed switch. 12. Faulty overspeed switch (reset & start).
Engine cranks but fails to start.	<ol style="list-style-type: none"> 1. Out of fuel. 2. Engine is flooded. <ol style="list-style-type: none"> a. Carburetor float needle valve open or damaged. Clean or replace the needle valve. b. Float in carburetor is leaking. Repair or replace float. c. Float chamber gasket damaged or securing screws are loose. Replace gasket and/or tighten screws. 3. Fuel pump inoperative. 4. Worn or faulty spark plugs. 5. High tension wires grounding (wet system). 6. Faulty ignition coil. 7. Faulty distributor. 8. Faulty run relay (K2). 9. Faulty wire connection. 10. No engine compression. 11. Faulty idle adjustment.

PROBLEM	PROBABLE CAUSE
Engine starts, runs and then shuts down.	<ol style="list-style-type: none"> 1. Faulty shutdown switch, (oil pressure, water or exhaust temperature). 2. High engine water or exhaust temperature. 3. Dirty fuel/water separator filter. 4. Mechanical check valve at the fuel supply faulty. (If installed). 5. Low oil level in sump. 6. Faulty fuel pump. 7. Faulty engine temperature sensor.
Engine starts, runs but does not come up to speed.	<ol style="list-style-type: none"> 1. Fuel line restriction. 2. Mechanical check valve at the fuel supply is faulty. 3. Throttle plate binding. 4. Faulty fuel pump. 5. Faulty wire connection. 6. Faulty engine temperature sensor. 7. AC generator overload. 8. High exhaust pressure.
Engine hunts.	<ol style="list-style-type: none"> 1. Low battery voltage. 2. Generator is overloaded. 3. Cracked distributor cap. 4. Faulty high tension wires. 5. Faulty fuel pump. 6. High exhaust back-pressure. 7. Valves are out of adjustment. 8. Governor is out of adjustment. 9. Dirty fuel filters. 10. Throttle linkage is binding.

NOTE: When troubleshooting a loss of ignition spark and the overspeed switch is suspect: By-pass the switch by lifting the T3 connector (overspeed terminal board) and connecting it to the vacant T4 spade connector. Start the engine and if the spark returns, the overspeed switch is at fault. Refer to the OVERSPEED WIRING DIAGRAM.



ENGINE TROUBLESHOOTING

PROBLEM	PROBABLE CAUSE
Engine misfires.	<ol style="list-style-type: none"> 1. Poor quality fuel. 2. Incorrect timing. 3. Dirty flame arrester. 4. Cracked distributor cap. 5. Faulty ignition wires. 6. Spark plugs are worn. 7. High exhaust back-pressure. 8. Valve clearances are incorrect.
Engine backfires.	<ol style="list-style-type: none"> 1. Spark plug wires are connected wrong. 2. Incorrect timing. 3. Engine is flooded. See <i>Engine is flooded under Engine cranks but fails to start.</i> 4. Dirty flame arrester. 5. Cracked distributor cap. 6. High exhaust back-pressure.
Engine overheats.	<ol style="list-style-type: none"> 1. Coolant loss. Pressure test cooling system. 2. Faulty raw water pump impeller. 3. Belts are loose or broken. 4. Raw water pump worn. 5. Faulty thermostat.
Low oil pressure.	<ol style="list-style-type: none"> 1. Low oil level. 2. Wrong SAE type oil in the engine. 3. Wrong type oil filter. 4. Relief valve is stuck. 5. Faulty oil pump. 6. Faulty engine bearings. 7. Faulty oil filter.
High oil pressure.	<ol style="list-style-type: none"> 1. Dirty oil or wrong SAE type oil in the engine. 2. Relief valve is stuck.

PROBLEM	PROBABLE CAUSE
No DC charge to the starting battery.	<ol style="list-style-type: none"> 1. Faulty connections to battery charging control. 2. Faulty battery charging control. 3. Faulty bridge rectifier. 4. Faulty generator charger windings.
Blue exhaust smoke discharge from the engine.	<ol style="list-style-type: none"> 1. Lube oil is diluted. 2. High lube oil level. 3. Crankcase breather hose is clogged. 4. Valves are worn or adjusted incorrectly. 5. Piston rings are worn or unseated.
Black exhaust smoke discharge from the engine.	<ol style="list-style-type: none"> 1. Dirty flame arrester. 2. Faulty carburetor. 3. Idle mixture jet too rich. 4. Accelerator diaphragm leaking. 5. Valves are worn or incorrectly adjusted. 6. Lube oil is diluted. 7. Piston rings are worn or unseated. 8. Crankcase breather hose is clogged.
Poor performance at generator speed.	<ol style="list-style-type: none"> 1. Main jet clogged. Remove and clean. 2. Carburetor inlet filter clogged. Remove and clean. 3. Fuel pump clogged. Remove and replace. 4. Air intake filter screen dirty. Remove and clean.

GENERATOR INFORMATION

USE OF ELECTRIC MOTORS

The power required to start an electric motor is considerably more than is required to keep it running after it is started. Some motors require much more current to start them than others. Split-phase (AC) motors require more current to start, under similar circumstances, than other types. They are commonly used on easy-starting loads, such as washing machines, or where loads are applied after the motor is started, such as small power tools. Because they require 5 to 7 times as much current to start as to run, their use should be avoided, whenever possible, if the electric motor is to be driven by a small generator. Capacitor and repulsion-induction motors require from 2 to 4 times as much current to start as to run. The current required to start any motor varies with the load connected to it. An electric motor connected to an air compressor, for example, will require more current than a motor to which no load is connected.

In general, the current required to start 115-Volt motors connected to medium starting loads will be approximately as follows:

MOTOR SIZE (HP)	AMPS FOR RUNNING (AMPERES)	AMPS FOR STARTING (AMPERES)
1/6	3.2	6.4 to 22.4*
1/4	4.6	9.2 to 32.2*
1/3	5.2	10.4 to 72.8*
1/2	7.2	14.4 to 29.2*
3/4	10.2	20.4 to 40.8*
1	13	26 to 52

***NOTE:** In the above table the maximum Amps for Starting is more for some small motors than for larger ones. The reason for this is that the hardest starting types (split-phase) are not made in larger sizes.

Because the heavy surge of current needed for starting motors is required for only an instant, the generator will not be damaged if it can bring the motor up to speed in a few seconds. If difficulty is experienced in starting motors, turn off all other electrical loads and, if possible, reduce the load on the electric motor.

Required Operating Speed

Run the generator first with no load applied, then at half the generator's capacity, and finally loaded to its full capacity as indicated on the generator's data plate. The output voltage should be checked periodically to ensure proper operation of the generating plant and the appliances it supplies. If an AC voltmeter or ampmeter is not installed to monitor voltage and load, check it with a portable meter and amprobe.

NOTE: When the vessel in which the generator is installed contains AC equipment of 120 volts only, it is recommended that the generator's AC terminal block be configured to provide one 120 volt AC hot leg for the vessel's distribution panel. This will ensure good motor starting response from the generator.

Generator Frequency Adjustment

Frequency is a direct result of engine/generator speed, as indicated by the following:

- When the generator is run at 1800 rpm, the AC voltage output frequency is 60 Hertz.
- When the generator is run at 1500 rpm, the AC voltage output frequency is 50 Hertz.

Therefore, to change the generator's frequency, the generator's drive engine's speed must be changed. Along with a reconfiguring of the AC output connections at the generator, a regulator board voltage output adjustment must also be made. See *ELECTRONIC GOVERNOR* in this manual.

Generator Maintenance

- Maintaining reasonable cleanliness is important. Connections of terminal boards and rectifiers may become corroded, and insulation surfaces may start conducting if salts, dust, engine exhaust, carbon, etc. are allowed to build up. Clogged ventilation openings may cause excessive heating and reduced life of windings.
- For unusually severe conditions, thin rust-inhibiting petroleum-base coatings, should be sprayed or brushed over all surfaces to reduce rusting and corrosion.
- In addition to periodic cleaning, the generator should be inspected for tightness of all connections, evidence of overheated terminals and loose or damaged wires.
- The drive discs on single bearing generators should be checked periodically if possible for tightness of screws and for any evidence of incipient cracking failure. Discs should not be allowed to become rusty because rust may accelerate cracking. The bolts which fasten the drive disc to the generator shaft must be hardened steel SAE grade 8, identified by 6 radial marks, one at each of the 6 corners of the head.
- The rear armature bearing is lubricated and sealed; no maintenance is required. However, if the bearing becomes noisy or rough-sounding, have it replaced.
- Examine bearing at periodic intervals. No side movement of shaft should be detected when force is applied. If side motion is detectable, bearings are wearing or wear on shaft of bearing socket outside bearing has occurred. Repair must be made quickly or major components will rub and cause major damage to generator.

Carbon Monoxide Detector

WESTERBEKE recommends mounting a carbon monoxide detector in the vessels living quarters. **Carbon monoxide, even in small amounts is deadly.**

The presence of carbon monoxide indicates an exhaust leak from the engine or generator, from the exhaust elbow/exhaust hose, or that fumes from a nearby vessel are entering your boat.

If carbon monoxide is present ventilate the area with clean air and correct the problem immediately!



BC GENERATOR SINGLE PHASE

NOTE: WESTERBEKE recommends that the following generator tests and adjustments be performed by a qualified technician.

DESCRIPTION

The BC generator is a brushless, self-excited generator which requires only the driving force of the engine to produce an AC output. The stator houses two sets of windings; the main stator windings and the exciter windings. When the generator is started, residual magnetism in the four rotating poles induces a voltage in the stator which then generates an even larger voltage in the exciter windings. This mutual build up of voltage in the four rotating poles and in the exciter windings quickly reaches the saturation point of the capacitor(s) and a regulated energy field is then maintained in the stator. At the same time, this regulated field produces a steady voltage in the stator windings which can then be drawn off the generator's AC terminals to operate AC equipment. The generator is a single-phase, reconnectable 120 volt AC two-wire or 240 volt AC three-wire, at 60 hertz; or 115 volt AC two-wire or 230 volt AC two-wire, at 50 hertz. Refer to the SPECIFICATIONS section of this manual for generator ratings. The generator's data plate gives the voltage, current and frequency rating of the generator. An AC wiring decal is affixed to the inside of the louvered cover at the generator end. A diagram of the various AC voltage connections is provided on the decal. An Integral Controller (IC) is mounted inside the generator and supplies a continuous DC charge to the generators starting battery when the generator is running. For more information see the INTEGRAL CONTROLLER DC CHARGER section in this manual.

Circuit Breaker

A circuit breaker is installed on all single phase WESTERBEKE generators. This circuit breaker will automatically disconnect generator power in case of an electrical overload. The circuit breaker can be manually shut off when servicing the generator to ensure that no power is coming into the boat.

NOTE: This circuit breaker is available as a WESTERBEKE add-on kit for earlier model generators; contact your WESTERBEKE dealer.

Circuit Breaker Part Numbers

- 7.0Kw #042714
- 5.8Kw #042713
- 4.5Kw #042232
- 3.8Kw #042712

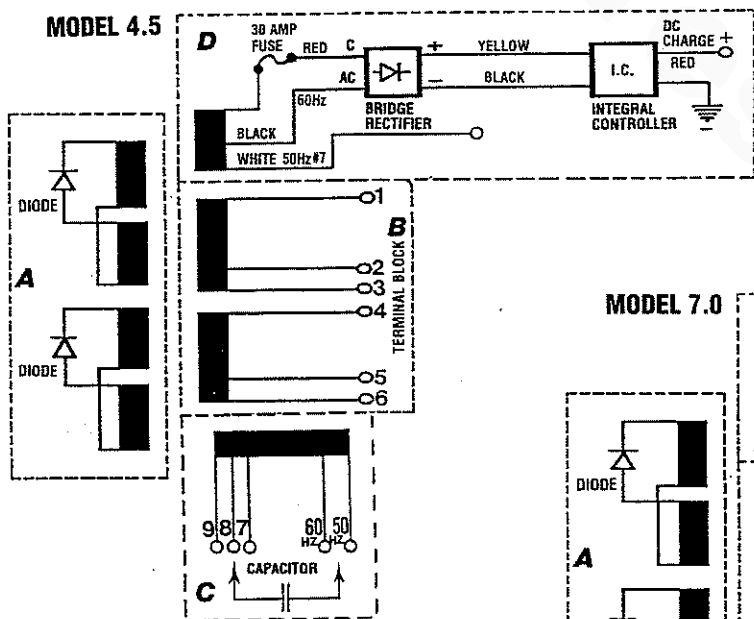
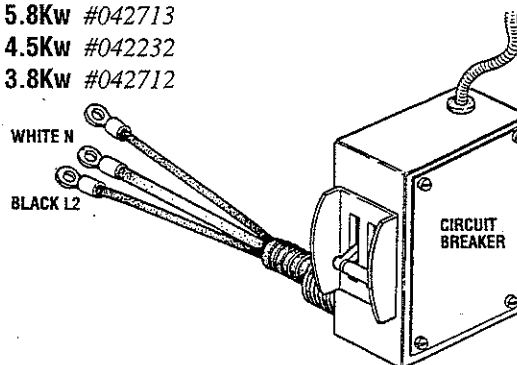

GENERATOR INTERNAL WIRING SCHEMATIC WITH DC BATTERY CHARGING CIRCUIT

- A** ROTATING FIELD/AUXILIARY WINDINGS WITH DIODES.
- B** MAIN STATOR WINDINGS.
- C** EXCITER WINDINGS AND CAPACITOR(S).
- D** DC BATTERY CHARGING CIRCUIT WITH BRIDGE RECTIFIER AND INTEGRAL CONTROLLER.

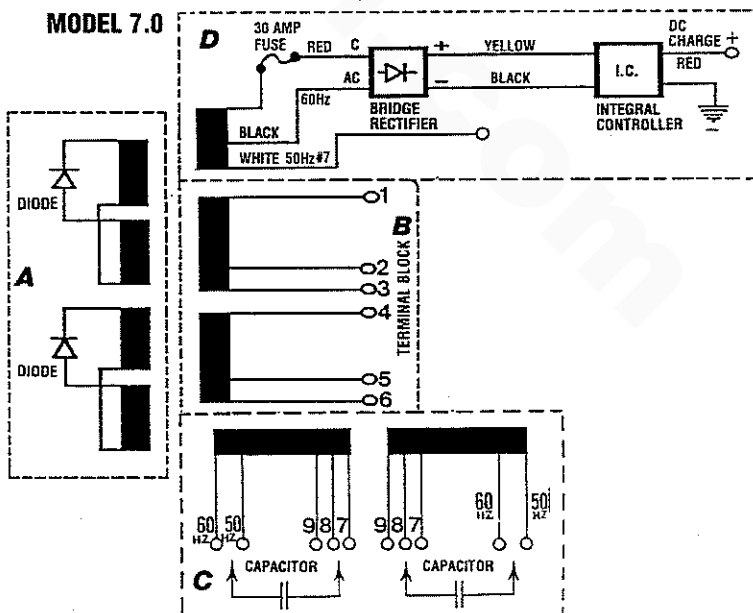

DUAL EXCITER CIRCUIT



BC GENERATOR SINGLE PHASE

NOTE: WESTERBEKE recommends that the following generator tests and adjustments be performed by a qualified technician.

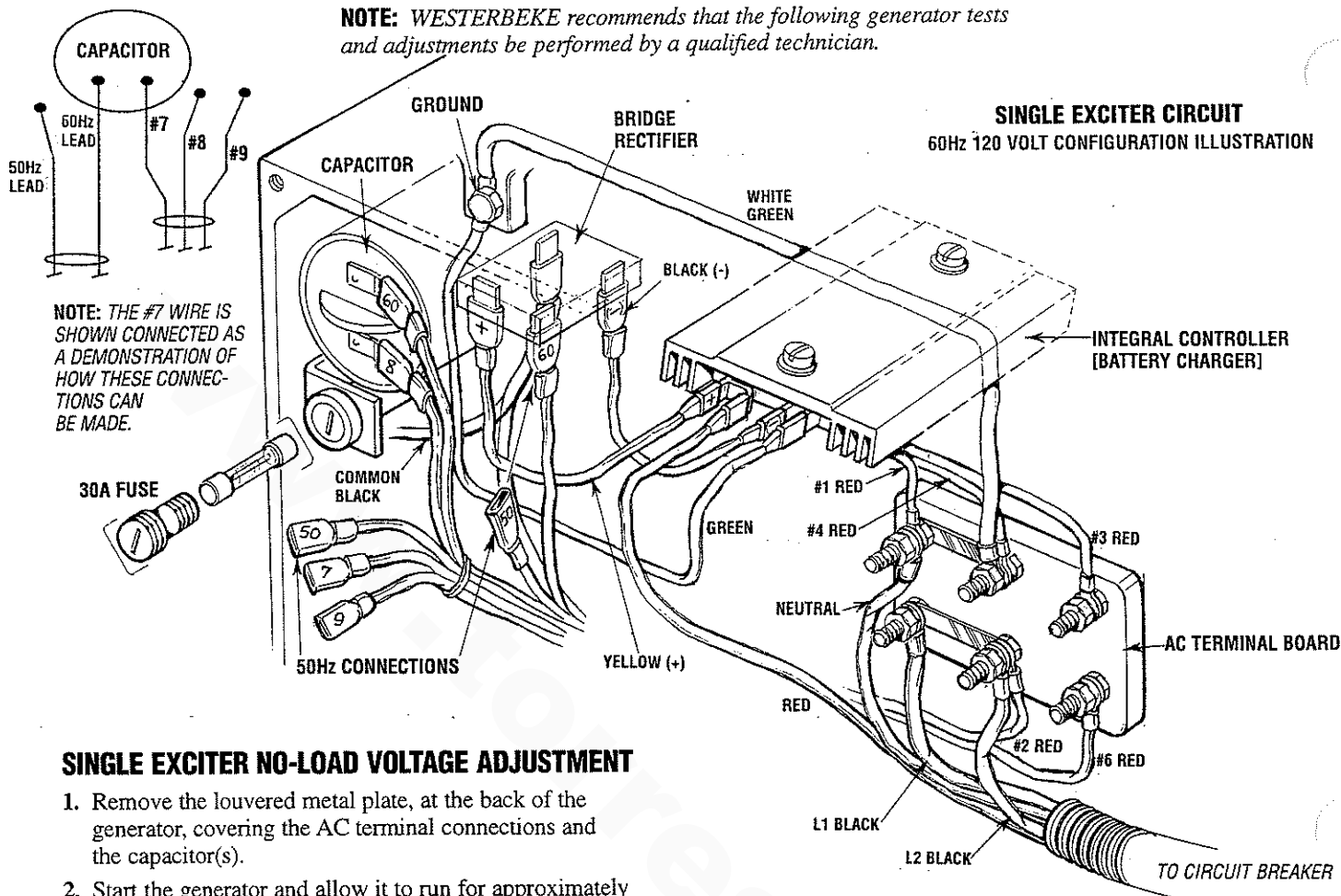

SINGLE EXCITER NO-LOAD VOLTAGE ADJUSTMENT

1. Remove the louvered metal plate, at the back of the generator, covering the AC terminal connections and the capacitor(s).
2. Start the generator and allow it to run for approximately five minutes so the engine can warm up. Make sure the generator is operating without any equipment drawing AC current from the generator (that is, shut off all electrical appliances). Make sure the engine's speed (Hertz) is correct. Adjust the governor as needed to obtain the correct engine speed before proceeding.
3. Refer to the AC LOAD CONNECTIONS DIAGRAM for the correct configuration then check the generator's no-load voltage by measuring the voltage across the neutral lead and the hot lead with a volt meter. Make sure you record this reading. The generator's no-load voltage is 115 - 124 volts at 60.5 - 61.5 Hertz. If the voltage output is higher or lower than specified, proceed.
4. **Shut off** the generator. Make sure the correct Hertz lead (60 Hertz #6, or 50 Hertz #5) is plugged into the capacitor(s).

WARNING: Capacitors must be discharged before handling as they store electricity and can pack a potentially lethal charge even when disconnected from their power source.

NOTE: Simply cross the capacitor's two terminals with an insulated (plastic handle) screwdriver. This will discharge any excess electricity.

WARNING: Do not attempt to make a no-load voltage adjustment while the generator is operating. The capacitor can produce a 400-500 volt charge. Touching any wiring can produce a severe electrical shock. In addition, attempting to make a no-load voltage adjustment while the generator is operating could cause your fingers to be caught in the generator's rotor.

5. There are three plugs grouped for the capacitor terminal, #7, #8, and #9. If the generator's no-load voltage is low, then disconnect the lower numbered plug and connect the plug with the next higher number. If the generator's no-load voltage is high, then disconnect the higher numbered plug and connect the plug with the next lower number. Note that the plug presently connected to this terminal may be any one of the three plugs available.
6. If the generator's no-load voltage cannot be adjusted because the voltage needs to be increased and the highest numbered plug is already connected to the right terminal, or the voltage needs to be lowered and the lowest numbered plug is connected, refer to the WESTERBEKE BC Generator Troubleshooting Guide).

BC GENERATOR SINGLE PHASE

NOTE: WESTERBEKE recommends that the following generator tests and adjustments be performed by a qualified technician.

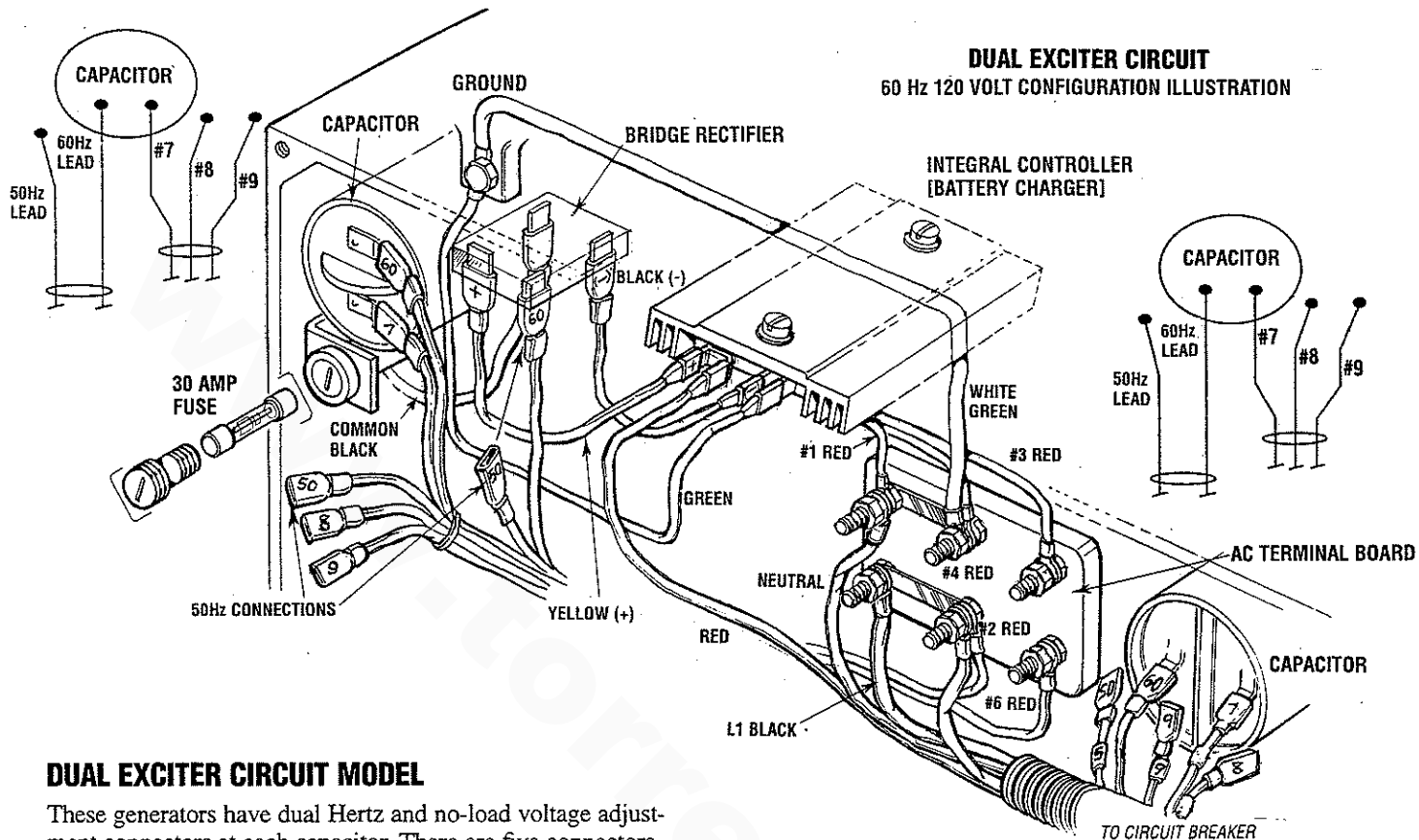

DUAL EXCITER CIRCUIT MODEL

These generators have dual Hertz and no-load voltage adjustment connectors at each capacitor. There are five connectors available for each capacitor. Two connectors are for Hertz selection, 60 Hertz or 50 Hertz, and three connectors, #7, #8, and #9, are for no-load voltage adjustment.

When making Hertz change or no-load voltage adjustments proceed as follows:

1. Shut the generator down.
2. Select the appropriate Hertz connection to plug into each capacitor #60, 60 Hertz, 1800 RPM or #50 Hertz, 1500 RPM. The three other connectors at each capacitor, #7, #8, and #9, will have an effect on the no-load voltage produced by the generator. One connector from each group can be plugged into each capacitor. No-load voltage will increase or decrease approximately 8 - 10 volts between connectors used in any pair combination to achieve the prescribed no-load voltages illustrated above.

⚠ WARNING: Make certain the insulating covers on the unused leads are in place and are NOT in contact with each other or in contact with the generator's

NOTE: Simply cross the capacitor's two terminals with an insulated (plastic handle) screwdriver. This will discharge any excess electricity.

NOTE: When changing Hertz produced by the generator, an engine speed adjustment at the governor **must** be made. The AC output connections on the terminal blocks **must** be selected for the voltage and Hertz to be produced. The Hertz plug connection at the capacitor **must** be changed for 50 Hertz (#5) or 60 Hertz (#6). The frame ground wire **must** be moved when changing from 115 volts, 50 Hertz to 230 volts, 50 Hertz.

⚠ WARNING: Capacitors must be discharged before handling as they store electricity and can pack a potentially lethal charge even when disconnected from their power source.

AC TERMINAL BOARD CONNECTIONS

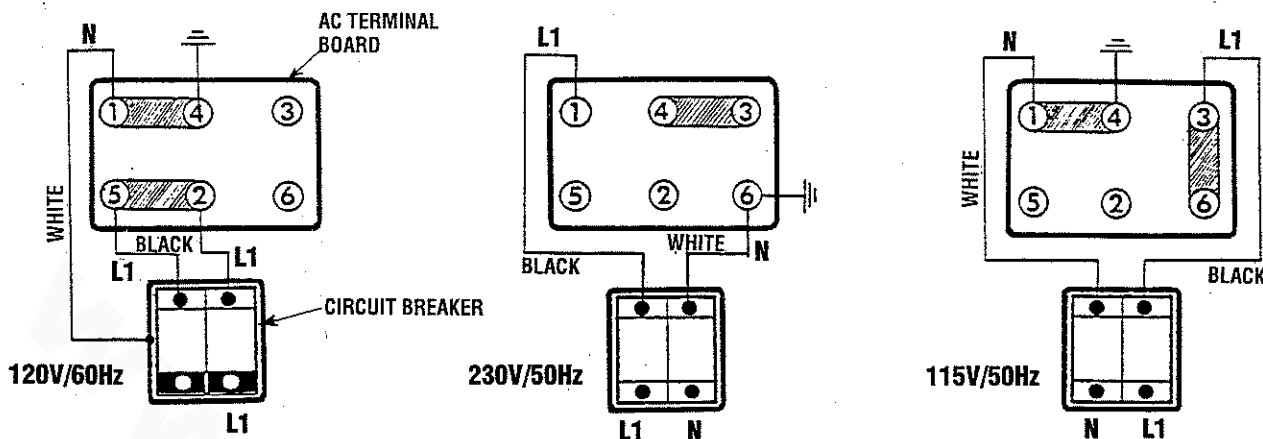

BATTERY CIRCUITS / RESISTANCE VALUES

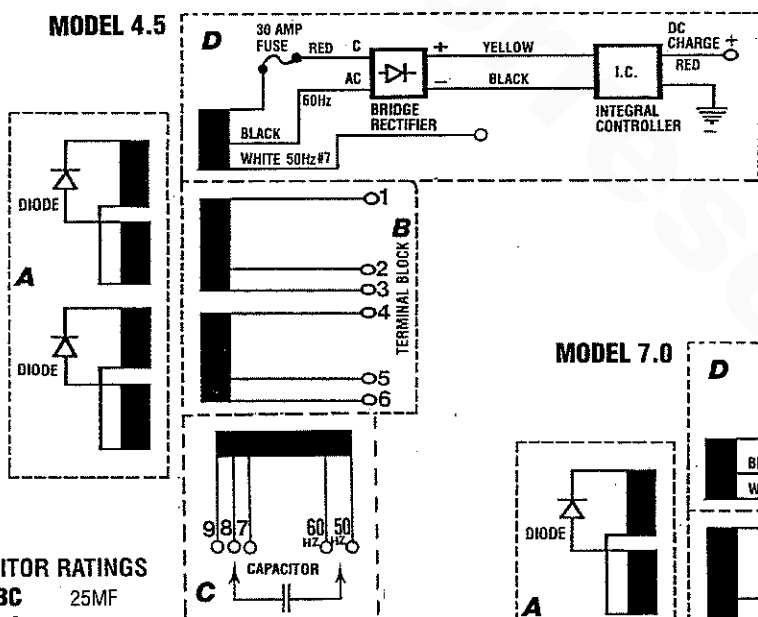

GENERATOR INTERNAL WIRING SCHEMATIC WITH DC BATTERY CHARGING CIRCUIT

- A** ROTATING FIELD/AUXILIARY WINDINGS WITH DIODES.
- B** MAIN STATOR WINDINGS.
- C** EXCITER WINDINGS AND CAPACITOR(S).
- D** DC BATTERY CHARGING CIRCUIT WITH BRIDGE RECTIFIER AND INTEGRAL CONTROLLER.

CAPACITOR RATINGS
 4.5 BC 25MF
 7.0 BC 31.5MF

WHEN CHECKING OR REPLACING A CAPACITOR, CHECK THE RATING ON THE CAPACITOR AND REPLACE WITH THE SAME RATING.

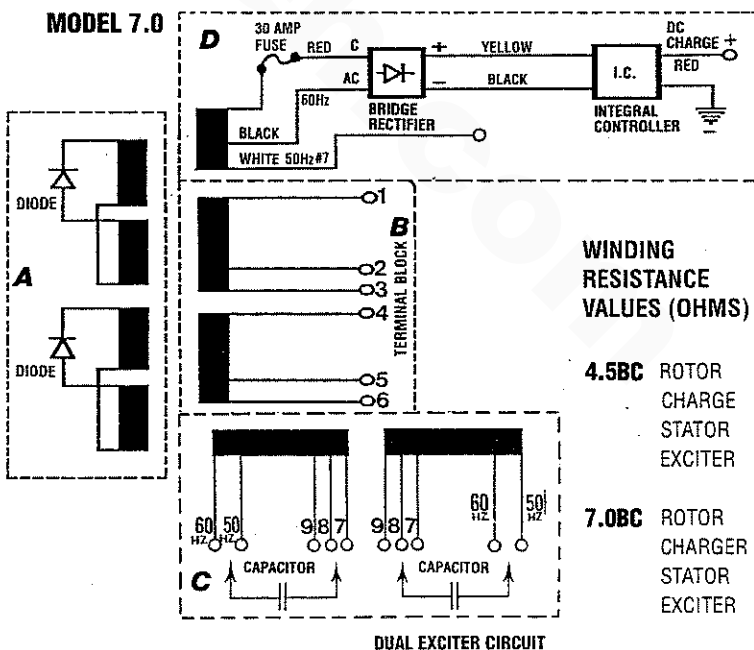

WINDING RESISTANCE VALUES (OHMS)

4.5BC	ROTOR	3.8
	CHARGE	0.1
	STATOR	0.6
	EXCITER	1.9
7.0BC	ROTOR	4.0
	CHARGER	0.1
	STATOR	0.4
	EXCITER	2.1

DUAL EXCITER CIRCUIT



BC GENERATOR SINGLE PHASE

TESTING THE EXCITER WINDINGS

Single Capacitor	Dual Exciter
1.9 Ohms	2.2 Ohms

An AC voltage is induced in these windings by the rotating field. Checking the residual voltage output from this winding can determine the condition of the winding when troubleshooting.

RESIDUAL VOLTAGE:

Single Capacitor Model: 10 - 14 Volts AC from each winding
 Dual Exciter Model: 7 - 9 Volts AC from each winding

AC voltage can be measured across the capacitor(s) while the generator is operating. This voltage may be as high as 400 to 500 volts AC. This voltage buildup is accomplished as the exciter windings charge the capacitor(s) and the capacitor(s) discharge back into the exciter windings. This AC voltage reading is taken between the #60 Hertz connector and the # connection plugged into the capacitor(s) while the generator is operating at its rated Hertz (61.5 - 62.0). This flow of saturating AC in the exciter windings produces a phase-imbalance type of field that effects the auxiliary windings: a beneficial result that produces good motor starting characteristics for this type of generator.

To measure the resistance value of the exciter windings, locate the #9 and the #50 Hertz capacitor connections.

NOTE: Three numbered capacitor connections exist: #7, #8, and #9; and two Hertz connections, #50 and #60.

Unplug any other connections from the capacitor(s) noting their position on the capacitor. Place one lead of the ohmmeter on plug connection #9 and the other lead on plug connection #50 Hertz. Measure the resistance value of the exciter windings. Check to make sure there is no continuity to the ground/generator case from either of the two leads. Also check that no continuity exists between either the #50 Hertz plug or the #9 plug and any of the main stator windings leads on the AC terminal block. If continuity is found here, a fault exists between these two winding groups.

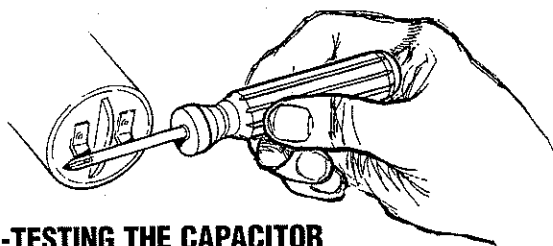

FIELD-TESTING THE CAPACITOR

With a capacitor meter, test the capacitor following the instructions included with the meter, and compare the results with the value shown on the capacitor. When a capacitor meter is not available, perform the following simple test:

1. Marking them so they may be reattached correctly, unplug the connections from the capacitor.
2. With a jumper, short across the two connections exposed in the previous step. This ensures the capacitor is discharged as it would be at shutdown.

3. With an ohmmeter set on the high R scale, place its plus (+) lead on one capacitor connection and the negative (-) lead on the other capacitor connection. A resistance should be read and should rise slowly as the meter attempts to charge the capacitor. This indicates a presumably good capacitor.
4. Indications of a defective capacitor:
 - a. Zero resistance or no rise in resistance value (shorted capacitor).
 - b. Infinite resistance (open capacitor).
 - c. No continuity should be found between the capacitor's connections and the capacitor's case or base.
5. Capacitor Ratings (Capacitor meter)
 - a. Single Capacitor Units: 25.0 microfarads (uF) 5°
 - b. Dual Capacitor Units: 31.5 microfarads (uF) 5°

NOTE: The capacitor rating is marked on the housing of the capacitor:

25.0 Microfarad capacitor PN 035985
 31.5 Microfarad capacitor PN 035978.

6. 12 volt DC excitation (low or no AC output voltage) the generator may be excited using 12 volts DC taken from the engine's starting battery. This voltage is applied across the #50 and #9 leads of the exciter circuit windings with any other numbered leads unplugged from the capacitors(s). The generator's reaction during flashing will help determine its fault.
7. During 12 volt excitation, output voltage ranges are as follows:

Single Capacitor	Dual Exciter
22 - 26 VAC	12 - 14 VAC

- a. A slight rise in the output voltage with the loading of the engine and/or a growling noise from the generator end will indicate a fault in the main stator windings.
- b. No rise or very slight rise in the output voltage will indicate a fault in the exciter windings.
- c. Normal output voltage as specified above, check exciter circuit capacitor(s).

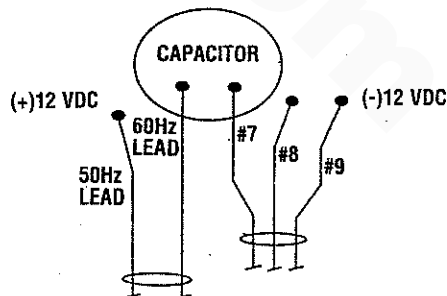

BC GENERATOR SINGLE PHASE Testing Component Resistance Values

Rotating Field/Auxiliary Windings and Diodes

Two sets of windings are found in the rotor assembly. An AC voltage is produced in two groups of windings as the rotor turns at rated rpm. The AC voltage passes through each of the two diodes mounted on the isolated fixture just before the rotor carrier bearing. The AC sine wave is changed to a DC and this DC voltage is passed through the two groups of rotating field windings producing a DC field around these windings. This field affects the AC winding of the two main stator groups inducing an AC voltage in these windings that is available at the AC terminal block connections.

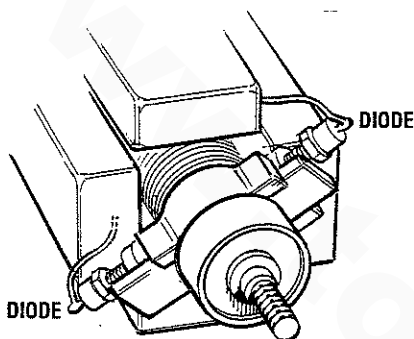

1. Rotating Field/Auxiliary Windings
Single Capacitor 3.8 Ohm — Dual Excitor — 4.0 Ohm

To check the resistance values, rotate the engine's crankshaft to position the diode(s) on the generator's shaft at 12 o'clock. To make a quick check of these windings, presume the diode is OK and place one of the ohmmeter's leads on the connection at the top of the diode and the other lead at the connection at the base of the diode. Compare readings with the value above. If a distinct difference is noted in the ohm value, carefully unsolder the lead on the top of the diode and remove the diode from its isolated heat sink using a thin walled, deep well 7/16 in (11 mm) socket.

NOTE: The aluminum heat sink that the diode threads into can be bent carefully outboard to make easier access to the diode.

With the diode removed, both leads for the first group of rotating field/auxiliary windings will be isolated with no interference from a possibly faulty diode.

Check the resistance value of the rotating windings by placing the ohmmeter's leads across the two exposed leads.

Also, verify that no continuity exists between these windings and the rotor shaft by leaving one ohmmeter lead attached to the winding lead and the other ohmmeter lead touching the shaft: no continuity should exist. If continuity is found, a short exists..

Repeat this same check on the second group of windings. Rotate the engine's crankshaft 180° to position the second diode and connections at 12 o'clock.

No continuity should be found between these two groups of windings.

2. Diodes 8 - 9.5 ohms (approximate) using a 260 Simpson Analog Meter

To check the diode, unsolder the connection from the top of the diode. Place one ohmmeter lead on the connection at the top of the diode and the other ohmmeter lead to the diode's base. Then reverse the position of the ohmmeter leads.

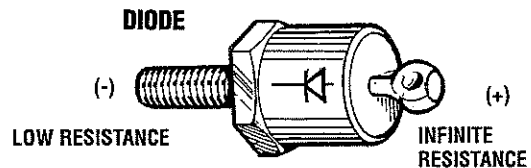

A low resistance should be found with the leads in one direction, and infinite resistance (blocking) in the other direction. Different meters will read different resistance values through the diode.

NOTE: Different meter models may show different ohm values, but should read the same for both diodes.

Diode Rating: 1600 amps 26 Amps

The diode's rating is far in excess of the circuit's requirements. Most likely a diode failure will result from an overspeed or load surge.

Main Stator Windings

Single Capacitor	Dual Excitor
0.6 Ohms	0.5 Ohms

Residual voltage measured between #1-#3 and #4-#6 will be 2-3 volts AC between each pair of leads at the terminal block. This would be an indication that the stator windings are okay. Check exciter windings and artificially excite the generator.

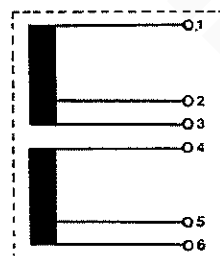

NOTE: THE NUMBERED LEADS ON THE TERMINAL BLOCK ARE NOT IN ANY NUMERICAL ORDER. THEY ARE AS SHOWN BELOW

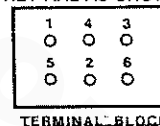

Group #1 - Measure resistance value between terminal with lead #1 and terminal with lead #3. (Check that there is no continuity of Group #1 windings to the case ground.)

Group #2 - Measure resistance value between terminal with lead #4 and terminal with lead #6. (Check that there is no continuity of Group #2 windings to the case ground.)

Check for a possible short between the two groups of stator windings by placing one lead of the ohmmeter on the terminal with the stator lead #3 and the other ohmmeter lead on the terminal with stator lead #6. There should be no continuity between the two groups of stator windings.



BC GENERATOR SINGLE PHASE

INTEGRAL CONTROLLER (I.C.)

The Integral Controller (I.C.) is an encapsulated, solid-state unit that supplies a DC charging voltage to the generator's starting battery while the generator is opening.

Charging Voltage: 13.0 - 14.0 volts DC
Charging Amperage: 0 - 17.0 amps DC

A separate group of stator windings supplies AC voltage to a bridge rectifier which converts the AC current to supply the I.C. unit. The I.C. unit senses the needs of the starting battery and supplies a DC charge when one is needed. If you suspect that the I.C. unit is faulty (that is, if the battery's charge is low), check the charging circuit and its components as described in the following steps. Check all connections for cleanliness and tightness including the ground before replacing the I.C. unit.

NOTE: When the generator is first started, the I.C. unit will produce a low charging rate. This charging rate will rise as the generator is operated.

The Integral Controller is mounted inside the generator housing in the 12:00 position. There is a voltage output adjustment on the controller that will allow a DC voltage output adjustment of ± 2 volts.

NOTE: New four wire controllers eliminate the ballast resistor circuit since the ballast resistor's function is now handled internally. Whenever replacing an early stylr controller with the newer four wire model, remove the ballast resistor and its wiring.

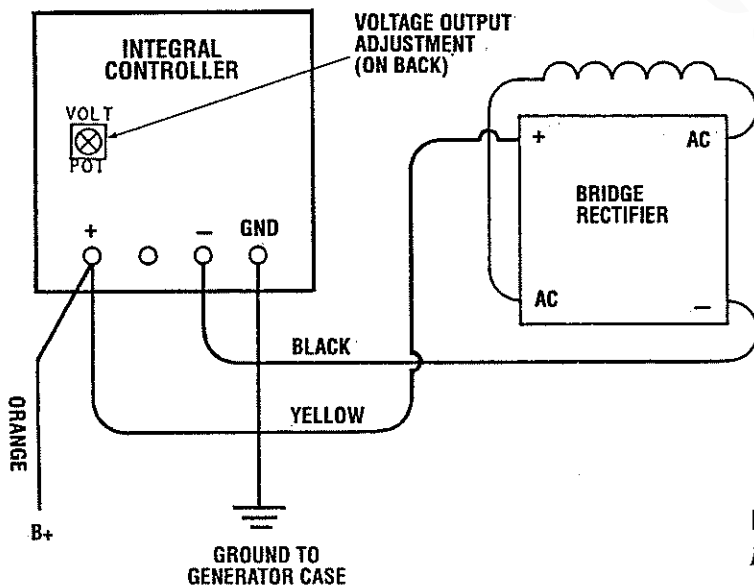

NOTE: Earlier model controllers had white/green (-) negative and white/black ground connections that are interchangeable.

Testing the Battery Charging Circuit

1. Bridge Rectifier

Normal AC voltage running to the rectifier (while the engine is operating at 1800 rpm) is measured across the two AC connections on the bridge rectifier. (As illustrated).

AC voltage running to the bridge rectifier (approximate):

No-load off the generator 16.0 volts AC

Full-load off the generator 17.5 volts AC

Normal DC voltage running out of the rectifier (in volts DC) is measured across the two DC connections of the bridge rectifier; that is + and -.

DC voltage running from the bridge rectifier (approximate):

No-load off the generator 17.0 volts DC

Full-load off the generator 18.5 volts DC

2. AC winding: 0.10 ohm

Lift the two AC wire leads off the bridge rectifier and measure, the resistance between these two leads with an ohmmeter. It should measure 0.10 ohm. No continuity should exist between these two leads and the ground or the main AC stator windings.

3. Testing the Bridge Rectifier (meter used - Simpson 260)

- Set your ohmmeter's scale on RX1 (+ DC) and set the needle to zero.
- Connect the (+) positive lead from the ohmmeter to point #4. Taking the ohmmeter's negative (-) lead, momentarily touch points #1, #2, #3, and #5. The ohmmeter should register no deflection for any of the points touched.
- Remove the positive (+) lead from point #4 and connect the negative (-) lead; momentarily touch points #1, #2, and #3. The ohmmeter's needle should deflect when each point is touched.
- Leaving the negative ohmmeter (-) lead on point #4, touch point #5 with the positive lead. No deflection should take place.
- Place the positive (+) lead on point #1 and the negative (-) lead on point #3. The ohmmeter again should not register any deflection (no deflection indicated infinite resistance). Reverse these connections and the ohmmeter should again register no deflection. If the rectifier fails any of the previous tests (A-E), replace the rectifier because it is defective.

NOTE: Different types and/or brands of test meters may produce opposite test results.

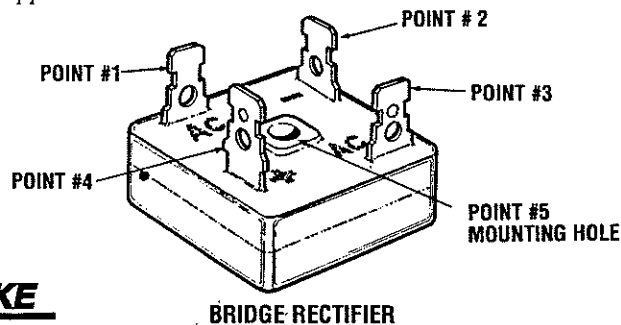

BATTERY CHARGING CIRCUIT

The DC Circuit on the BCGB functions to start, operate and stop the generator's engine. The circuit is best understood by reviewing the DC Wiring Diagram and Wiring Schematic. The engine's DC wiring is designed with three simple basic circuits: start, run and stop.

The engine has a 12 volt DC electrical control circuit that is shown on the Wiring Diagrams. Refer to these diagrams when troubleshooting or when servicing the DC electrical system or the engine.

BATTERIES

CAUTION: To avoid damage to the battery charging circuit, never shut off the engine battery switch while the engine is running. Shut off the engine battery switch, however, to avoid electrical shorts when working on the engine's electrical circuit.

Specifications

The minimum recommended capacity of the battery used in the engine's 12-volt DC control circuit is 300 CCA.

BATTERY CHARGING

The generator supplies a continuous 17 amp charge from its battery charger to the starting battery.

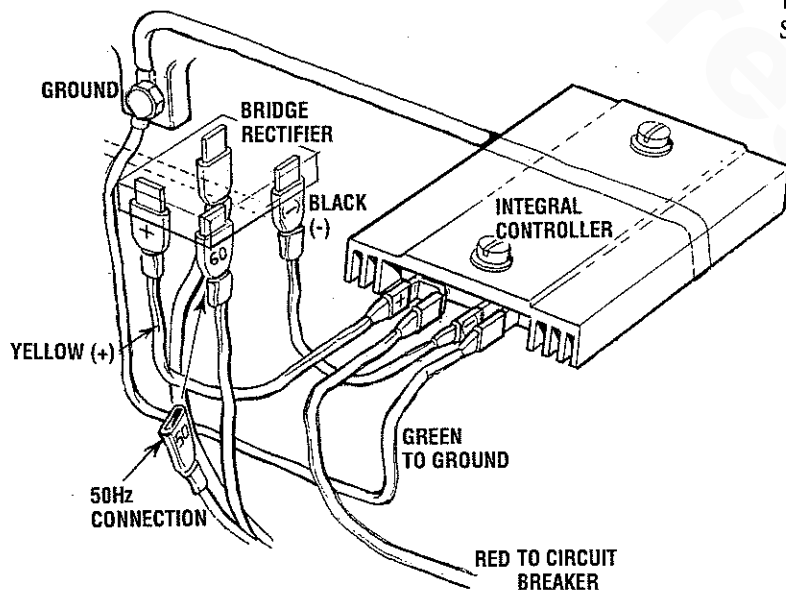

NOTE: Should the battery charger or bridge rectifier fail, the generator windings are protected by a 30 amp fuse.

Battery Maintenance

Review the manufacturer's recommendations and then establish a systematic maintenance schedule for your engine's starting batteries and house batteries.

- Monitor your voltmeter for proper charging during engine operation.
- Check the electrolyte level and specific gravity with a hydrometer.
- Use only distilled water to bring electrolytes to a proper level.
- Make certain that battery cable connections are clean and tight to the battery posts (and to your engine).
- Keep your batteries clean and free of corrosion.

WARNING: Sulfuric acid in lead batteries can cause severe burns on skin and damage clothing. Wear protective gear.

COMPONENT TESTING

Refer to *COMPONENT TESTING* in this section.

TESTING THE CHARGING CIRCUIT

See the next page.

TESTING THE BATTERY CHARGING CIRCUIT

BATTERY CHARGER

The generator supplies a continuous 17 amp charge from its battery charger to the starting battery. To test the battery charger put a multimeter between the positive (+) and negative (-) leads to the battery. It should indicate 13.5V to 14V with the engine running. If only the battery voltage is indicated, check that the battery charger terminal connections are tight. With the unit running, test between the (+) and (-) terminals for 13.5V to 14V. If no charge is indicated, replace the charger.

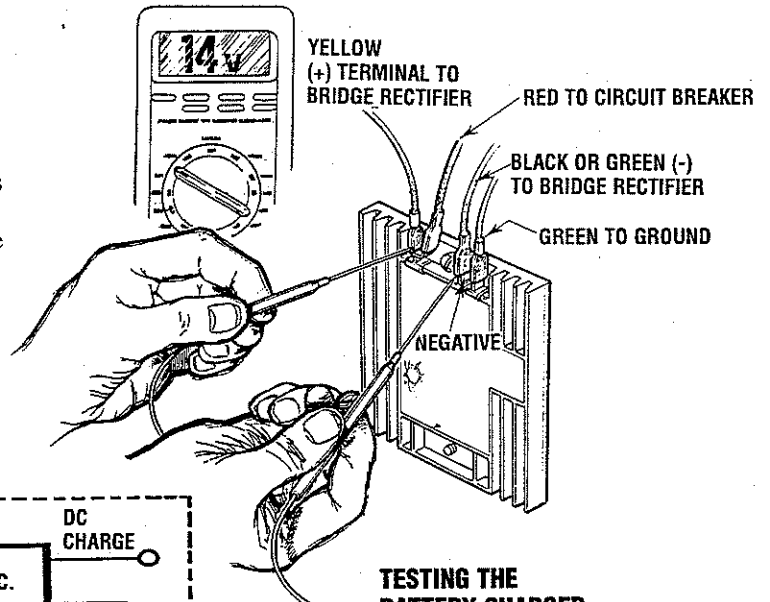

TESTING THE BATTERY CHARGER

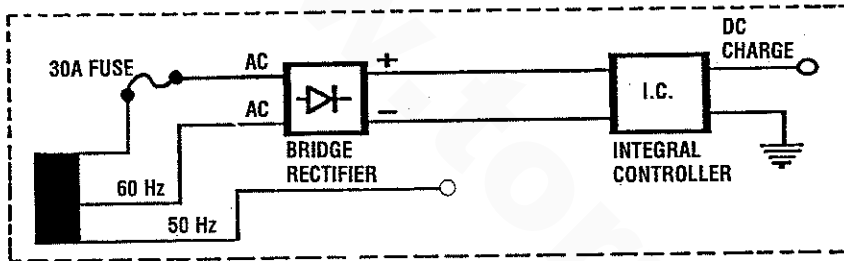

SHORE POWER TRANSFER SWITCH

120 VOLT/60 HERTZ TWO WIRE CONFIGURATION

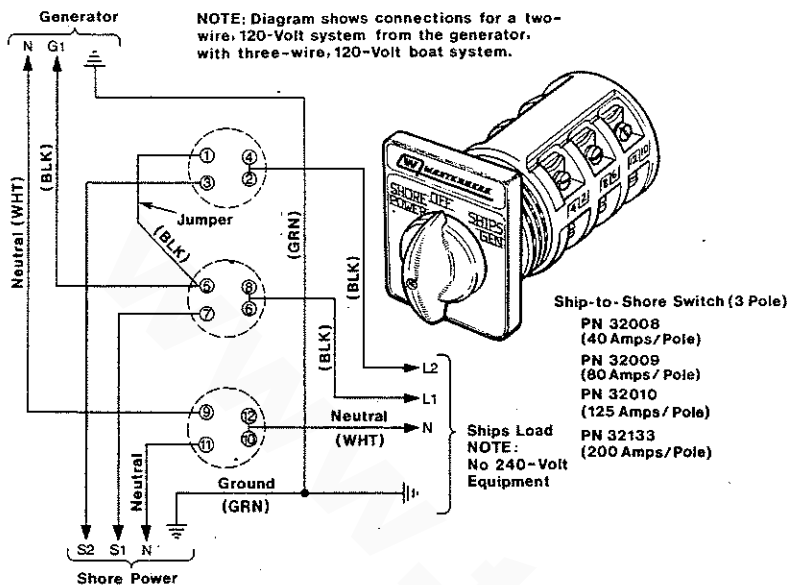

If the installer connects shore power to the vessel's AC circuit, this must be done by means of the Shore Power Transfer Switch. Set the transfer switch shown in the diagrams to the OFF position. This switch prevents simultaneous connection of shore power to generator output.

CAUTION: Damage to the generator can result if utility shore power and generator output are connected at the same time. This type of generator damage is not covered under the warranty; it is the installer's responsibility to make sure all AC connections are correct.

230 VOLT/50 HERTZ TWO WIRE CONFIGURATION

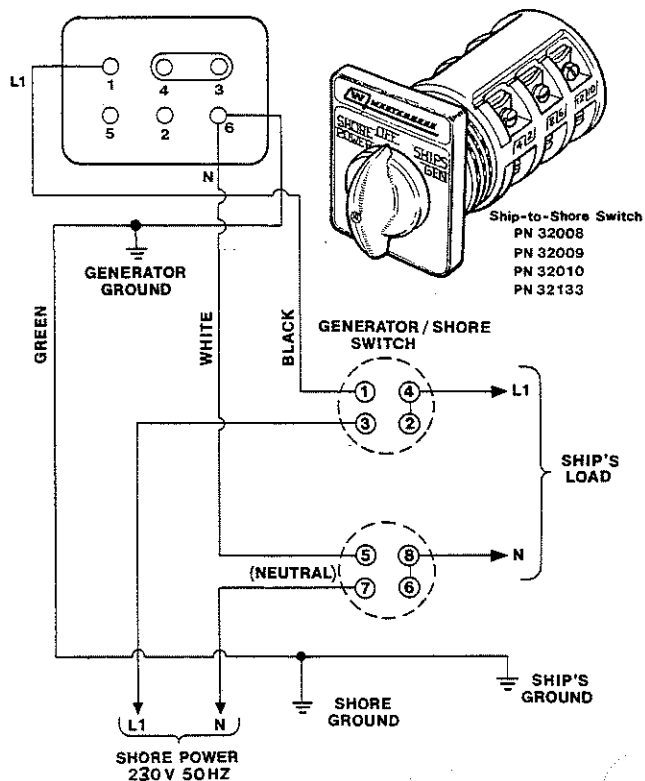

Switching Shore Power to Generator Power

CAUTION: Heavy motor loads should be shut off before switching shore power to generator power or vice-versa because voltage surges induced by switching with heavy AC loads on the vessel being operated may cause damage to the exciter circuit components in the generator.

LAY-UP & RECOMMISSIONING

General

Many owners rely on their boatyards to prepare their craft, including engines and generators, for lay-up during the off-season or for long periods of inactivity. Others prefer to accomplish lay-up preparation themselves.

The procedures which follow will allow you to perform your own lay-up and recommissioning, or will serve as a checklist if others do the procedures.

These procedures should provide protection for your engine/generator during a lay-up and also help familiarize you with its maintenance needs.

If you have any questions regarding lay-up procedures, call your local servicing dealer. He will be more than willing to provide assistance.

Propeller Shaft Coupling [Propulsion Engine]

The transmission and propeller half couplings should always be opened up and the bolts removed when the boat is hauled out of the water or moved from land to water, and during storage in the cradle. The flexibility of the boat often puts a severe strain on the propeller shaft or coupling or both, while the boat is taken out or put in the water. In some cases, the shaft has actually been bent by these strains. This does not apply to small boats that are hauled out of the water when not in use, unless they have been dry for a considerable period of time.

Fresh Water Cooling Circuit

A 50-50 solution of antifreeze and distilled water is recommended for use in the fresh water cooling system at all times. This solution may require a higher concentration of antifreeze, depending on the area's winter climate. Check the solution to make sure the antifreeze protection is adequate.

Should more antifreeze be needed, drain an appropriate amount from the engine block and add a more concentrated mixture. Operate the engine to ensure a complete circulation and mixture of the antifreeze concentration throughout the cooling system. Then recheck the antifreeze solution's strength.

Lubrication System

With the engine warm, drain all the engine oil from the oil sump. Remove and replace the oil filter and fill the sump with new oil. Use the correct grade of oil. Refer to the *ENGINE LUBRICATING OIL* pages in this manual for "engine oil change".

Run the engine and check for proper oil pressure and make sure there are no leaks.

CAUTION: Do not leave the engine's old engine oil in the sump over the lay-up period. Engine oil and combustion deposits combine to produce harmful chemicals which can reduce the life of your engine's internal parts.

Fuel System [Gasoline]

Top off your fuel tanks with *unleaded* gasoline of 89 octane or higher. A fuel conditioner such as *STABIL* gasoline stabilizer should be added. Change the element in your gasoline/water separator and clean the metal bowl. Re-install and make certain there are no leaks. Clean up any spilled fuel.

Fuel System [Diesel]

Top off your fuel tanks with No.2 diesel fuel. Fuel additives such as *BIOBOR* and *STABIL* should be added at this time to control algae and condition the fuel. Care should be taken that the additives used are compatible with the primary fuel filter/water separator used in the system. Change the element in your primary fuel filter/water separator, if the fuel system has one, and clean the separator sediment bowl.

Change the fuel filter elements on the engine and bleed the fuel system, as needed. Start the engine and allow it to run for 5 - 10 minutes to make sure no air is left in the fuel system. Check for any leaks that may have been created in the fuel system during this servicing, correcting them as needed. Operating the engine for 5 - 10 minutes will help allow movement of the treated fuel through the injection equipment on the engine.

Raw Water Cooling Circuit

Close the through-hull fitting. Remove the raw water intake hose from the fitting. Place the end of this hose into a five gallon bucket of clean fresh water. Before starting the engine, check the zinc anode found in the primary heat exchanger on the engine and clean or replace it as required and also clean any zinc debris from inside the heat exchanger where the zinc anode is located. Clean the raw water strainer.

Start the engine and allow the raw water pump to draw the fresh water through the system. When the bucket is empty, stop the engine and refill the bucket with an antifreeze solution slightly stronger than needed for winter freeze protection in your area.

Start the engine and allow all of this mixture to be drawn through the raw water system. Once the bucket is empty, stop the engine. This antifreeze mixture should protect the raw water circuit from freezing during the winter lay-up, as well as providing corrosion protection.

Remove the impeller from your raw water pump (some antifreeze mixture will accompany it, so catch it in a bucket). Examine the impeller. Get a replacement, if needed, and a cover gasket. Do not replace the impeller (into the pump) until recommissioning, but replace the cover and gasket.

Intake Manifold and Thru-Hull Exhaust

Place a clean cloth, lightly soaked in lubricating oil, in the opening of the intake manifold to block the opening. Do not shove the cloth out of sight. (If it is not visible at recommissioning, and an attempt is made to start the engine, you may need assistance of the servicing dealer). Make a note to remove the cloth prior to start-up. The thru-hull exhaust port can be blocked in the same manner.

LAY-UP & RECOMMISSIONING

Starter Motor

Lubrication and cleaning of the starter drive pinion is advisable, if access to the starter permits its removal. Make sure the battery connections are shut off before attempting to remove the starter. Take care in properly replacing any electrical connections removed from the starter.

Cylinder Lubrication

If you anticipate a long lay-up period (12 months or more) WESTERBEKE recommends removing the fuel injectors for access to the cylinders. Squirt light lubricating oil into the cylinders to prevent the piston rings from sticking to the cylinder walls.

Make sure you have replacements for the injector and return line sealing washers.

Intake Manifold [Gasoline]

Clean the filter screen in the flame arrester, and place a clean cloth lightly soaked in lube oil around the flame arrester to block any opening. Also place an oil-soaked cloth in the through-hull exhaust port. Make a note to remove cloths prior to start-up!

Cylinder Lubrication [Gasoline]

Spray fogging oil into the open air intake, with the flame arrester removed, while the generator is running. The fogging oil will stall out the engine and coat the valves, cylinders and spark plugs for winter protection.

NOTE: *The spark plugs will need to be removed for cleaning and regapping at spring commissioning.*

Batteries

If batteries are to be left on board during the lay-up period, make sure that they are fully charged, and will remain that way, to prevent them from freezing. If there is any doubt that the batteries will not remain fully charged, or that they will be subjected to severe environmental conditions, remove the batteries and store them in a warmer, more compatible environment.

WARNING: *Lead acid batteries emit hydrogen, a highly-explosive gas, which can be ignited by electrical arcing or a lighted cigarette, cigar, or pipe. Do not smoke or allow an open flame near the battery being serviced. Shut off all electrical equipment in the vicinity to prevent electrical arcing during servicing.*

Transmission [Propulsion Engine]

Check or change the fluid in the transmission as required. Wipe off grime and grease and touch up any unpainted areas. Protect the coupling and the output flange with an anti-corrosion coating. Check that the transmission vent is open.

Spare Parts

Lay-up time provides a good opportunity to inspect your WESTERBEKE engine to see if external items such as drive belts or coolant hoses need replacement. Check your basic spares kit and order items not on hand, or replace those items used during the lay-up, such as filters and zinc anodes. Refer to *SPARE PARTS* section of this manual.

Recommissioning

The recommissioning of your WESTERBEKE engine after a seasonal lay-up generally follows the same procedures as those presented in the *PREPARATIONS FOR STARTING* section regarding preparation for starting and normal starts. However, some of the lay-up procedures will need to be counteracted before starting the engine.

1. Remove the oil-soaked cloths from the intake manifold
2. Remove the raw water pump cover and gasket, and discard the old gasket. Install the raw water pump impeller removed during lay-up (or a replacement, if required). Install the raw water pump cover with a new cover gasket.
3. Reinstall the batteries that were removed during the lay-up, and reconnect the battery cables, making sure the terminals are clean and that the connections are tight. Check to make sure that the batteries are fully charged.

CAUTION: *Wear rubber gloves, a rubber apron, and eye protection when servicing batteries. Lead acid batteries emit hydrogen, a highly explosive gas, which can be ignited by electrical arcing or a lighted cigarette, cigar, or pipe. Do not smoke or allow an open flame near the battery being serviced. Shut off all electrical equipment in the vicinity to prevent electrical arcing during servicing.*

4. Remove the spark plugs, wipe clean, re-gap, and install to proper tightness [gasoline].
5. Check the condition of the zinc anode in the raw water circuit and clean or replace the anode as needed. Note that it is not necessary to flush the antifreeze/fresh water solution from the raw water coolant system. When the engine is put into operation, the system will self-flush in a short period of time with no adverse affects. It is advisable, as either an end of season or recommissioning service, to inspect the area where the zinc is located in the heat exchanger and clear any and all zinc debris from that area.
6. Start the engine in accordance with procedures described in the *PREPARATIONS FOR INITIAL START-UP* section of this manual.

GENERATOR SPECIFICATIONS

ENGINE SPECIFICATIONS	
Engine Type	3 cylinder, 4 cycle, overhead camshaft w/counterbalance shaft, carbureted water cooled gasoline engine
Bore & Stroke	2.56 x 2.61 inches (65.0 x 66.3 mm.)
Total Displacement	40.3 cubic inches (.66 liter)
Bearings	Four main bearings
Combustion Chamber	Semi-spherical
Compression Ratio	9.8 - 1
Firing Order	1 - 3 - 2
Aspiration	Naturally aspirated
Direction of Rotation	Counterclockwise viewed from the back end
Inclination	25° continuous, all directions 30° temporary, all directions
Governor	Mechanical
FUEL SYSTEM	
Fuel Pump	Electric fuel pump
Fuel	Unleaded 89 octane or higher gasoline
Distributor	Breakerless distributor
Spark Plugs	14 mm
Ignition Coil	12 volt
Flame Arrester	Metal screen type
Carburetor	Single-barrel downdraft type
ELECTRICAL SYSTEM	
Start Motor	12 volt reduction gear with solenoid
Starting Battery	12 volt negative ground
Battery Capacity	150 Cold Cranking Amps(CCA)(min)
Battery Charging	Integral electric, 17 amps

EXHAUST EMISSIONS SYSTEMS	
EM	Engine Modification
COOLING SYSTEM	
General	Fresh water-cooled block through raw water-cooled heat exchanger circuit
Fresh Water Pump	Centrifugal type, metal impeller, belt-driven
Raw Water Pump	Positive displacement, rubber impeller, belt driven.
Cooling Water Capacity	3.5 qts (3.4 liters)
LUBRICATING SYSTEM	
Type	Forced lubrication by gear pump
Oil Filter	Fuel flow, paper element, spin-on disposals
Oil Capacity	2.7 qts. (2.6 liters)
Oil Grade	API Specification SJ class
AC GENERATOR (SINGLE PHASE)	
Type	Brushless, four pole capacitor, regulated. 1800 rpm/60Hz, 1500 rpm/50Hz
Ratings	
4.5KW	120/240 volts, 37.5/18.7 amps, 60 Hz single phase, 4 wire, 1.0 power factor
3.8KW	230 volts, 13 amps, 50 Hz, single phase, 4 wire, 1.0 power factor
7.0KW	120/240 volts, 58.3/29.2 amps, 60 Hz, single phase, 4 wire, 1.0 power factor
5.0KW	230 volts, 21.7 amps, 50 Hz, single phase, 4 wire, 1.0 power factor
TUNE-UP SPECIFICATIONS	
Spark Plug Gap	0.031 ± .002 inches (0.8 ± 0.05 mm)
Spark Plug Torque	10.8 - 15.2 lb-ft
Cylinder Head Torque	60 - 70 Nm 43 - 51 ft-lbs
Bolt Torque	See <i>TORQUING THE CYLINDER HEAD</i>

STANDARD HARDWARE

BOLT HEAD MARKINGS

Bolt strength classes are embossed on the head of each bolt.

Customary (inch) bolts are identified by markings two to grade eight (strongest). The marks correspond to two marks less than the actual grade, i.e.; a grade seven bolt will display five embossed marks.

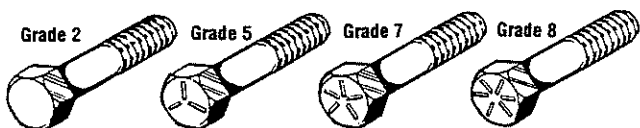

Metric bolt class numbers identify bolts by their strength with 10.9 the strongest.

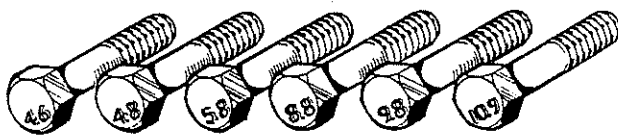

- NOTES:**
1. Use the torque values listed below when specific torque values are not available.
 2. These torques are based on clean, dry threads. Reduce torque by 10% when engine oil is used.
 3. Reduce torques by 30% or more, when threading capscrews into aluminum.

STANDARD BOLT & NUT TORQUE SPECIFICATIONS			
Capscrew Body Size (Inches) - (Thread)	SAE Grade 5 Torque Ft-Lb (Nm)	SAE Grade 6-7 Torque Ft-Lb (Nm)	SAE Grade 8 Torque Ft-Lb (Nm)
1/4 - 20 - 28	8 (11) 10 (14)	10 (14)	12 (16) 14 (19)
5/16 - 18 - 24	17 (23) 19 (26)	19 (26)	24 (33) 27 (37)
3/8 - 16 - 24	31 (42) 35 (47)	34 (46)	44 (60) 49 (66)
7/16 - 14 - 20	49 (66) 55 (75)	55 (75)	70 (95) 78 (106)
1/2 - 13 - 20	75 (102) 85 (115)	85 (115)	105 (142) 120 (163)
9/16 - 12 - 18	110 (149) 120 (163)	120 (163)	155 (210) 170 (231)
5/8 - 11 - 18	150 (203) 170 (231)	167 (226)	210 (285) 240 (325)
3/4 - 10 - 16	270 (366) 295 (400)	280 (380)	375 (508) 420 (569)
7/8 - 9 - 14	395 (536) 435 (590)	440 (597)	605 (820) 675 (915)
1 - 8 - 14	590 (800) 660 (895)	660 (895)	910 (1234) 990 (1342)

NOTE: Formula to convert Ft-Lbs to Metric (M-Kg) is Ft-Lb x .1383 = M-Kg

METRIC BOLT & NUT TORQUE SPECIFICATIONS					
Bolt Dia.	Wrench Size	Grade 4.6 Ft-Lb (Nm)	Grade 4.8 Ft-Lb (Nm)	Grade 8.8 - 9.8 Ft-Lb (Nm)	Grade 10.9 Ft-Lb (Nm)
M3 M4 M5	5.5 mm 7 mm 8 mm	0.3 (0.5) 0.8 (1.1) 1.5 (2.5)	0.5 (0.7) 1 (1.5) 2 (3)	1 (1.3) 2 (3) 4.5 (6)	1.5 (2) 3 (4.5) 6.5 (9)
M8 M9 M10	10 mm 13 mm 16 mm	3 (4) 7 (9.5) 14 (19)	4 (5.5) 10 (13) 18 (25)	7.5 (10) 18 (25) 37 (50)	11 (15) 35 (26) 55 (75)
M12 M14 M16	18 mm 21 mm 24 mm	26 (35) 37 (50) 59 (80)	33 (45) 55 (75) 85 (115)	63 (85) 103 (140) 159 (215)	97 (130) 151 (205) 232 (315)
M18 M20 M22	27 mm 30 mm 33 mm	81 (110) 118 (160) 159 (215)	118 (160) 166 (225) 225 (305)	225 (305) 321 (435) 435 (590)	321 (435) 457 (620) 620 (840)
M24 M27 M30	36 mm 41 mm 46 mm	203 (275) 295 (400) 402 (545)	288 (390) 417 (565) 568 (770)	553 (750) 811 (1100) 1103 (1495)	789 (1070) 1154 (1565) 1571 (2130)
M33 M36	51 mm 55 mm	546 (740) 700 (950)	774 (1050) 992 (1345)	1500 (2035) 1925 (2610)	2139 (2900) 2744 (3720)

SEALANTS & LUBRICANTS

GASKETS/SEALANTS

Oil based PERMATEX #2 and it's HIGH TACK equivalent are excellent all purpose sealers. They are effective in just about any joint in contact with coolant, raw water, oil or fuel.

A light coating of OIL or LIQUID TEFLON can be used on rubber gaskets and O-rings.

LOCTITE hydraulic red sealant should be used on oil adapter hoses and the oil filter assembly.

Coat both surfaces of the oil pan gasket with high temp RED SILICONE sealer.

When installing gaskets that seal around water (coolant) passages, coat both sides with WHITE SILICONE grease.

High-copper ADHESIVE SPRAYS are useful for holding gaskets in position during assembly.

Specialized gasket sealers such as HYLOMAR work well in applications requiring non-hardening properties. HYLOMAR is particularly effective on copper cylinder-head gaskets as it resists fuel, oil and water.

Use LIQUID TEFLON for sealing pipe plugs and fillings that connect coolant passages. **Do not use tape sealants!**

BOLTS & FASTENERS/ASSEMBLIES

Lightly oil head bolts and other fasteners as you assemble them. Bolts and plugs that penetrate the water jacket should be sealed with PERMATEX #2 or HIGH TACK.

When assembling the flywheel, coat the bolt threads with LOCTITE blue.

Anti-seize compounds and thread locking adhesives such as LOCTITE protect threaded components yet allows them to come apart when necessary. LOCTITE offers levels of locking according to the job.

LITHIUM based grease is waterproof, ideal for water pump bearings and stuffing boxes.

Heavily oil all sliding and reciprocating components when assembling. **Always use clean engine oil!**



BCGB GENERATOR HARDWARE TORQUES

Timing Belt	Nm	ft. lbs.
Crankshaft bolt	135-145	98-105
Timing belt cover bolts	10-12	7-9
Camshaft sprocket bolts	80-100	58-72
Oil pump sprocket nuts	50-57	36-41
Timing tensioner nuts	22-30	16-22
Timing belt rear cover bolts	10-12	7-9
Rocker Arms and Rocker Shaft		
Rocker cover shaft	29-35	21-25
Camshaft thrust plate bolt	10-12	7-9
Rocker arm adjust nut	8-10	6-7
Cylinder Head, Valve		
Cylinder head bolt (cold engine)	60-70	43-51
Spark plug	15.2	10.8
Rocket cover	12-13	9-10
Miscellaneous		
Coolant temperature sender	12-18	9-13
Coolant temperature switch	12-18	9-13
Generator mounts	34-47	23-34
Exhaust manifold	16-23	12-17
Thermostat housing	8-11	6-8

Front Case, Counterbalance Shaft	Nm	ft. lbs.
Front case bolts	8-10	6-7
Oil pump cover bolts	8-10	6-7
Oil pan bolts	10-12	7-9
Oil drain plug	35-45	25-33
Oil screen bolts	15-22	11-16
Oil pump driven gear bolt	34-40	25-29
Rear cover bolts	10-12	7-9
Piston and Connecting Rod		
Connecting rod cap nut	15 + 90° turn	11 + 90° turn
Crankshaft, Bearing		
Oil seal case bolts	10-12	7-9
Bearing cap bolts	50-55	36-40
Cylinder Block		
Taper plug 1/16	8-12	6-9
Taper plug 1/8	15-22	11-16
Water drain plug	35-45	25-33
Taper plug 1/4 NPT	35-45	25-33
Oil pressure switch	12-18	9-13
Oil pressure sender	12-18	9-13
Water Pump		
Water pump	8-10	6-7

METRIC CONVERSIONS

INCHES TO MILLIMETERS

MILLIMETERS TO INCHES

Inches	mm	Inches	mm	mm	Inches	mm	Inches
1	25.40	15	381.00	1	0.0394	15	0.5906
2	50.80	20	508.00	2	0.0787	20	0.7874
3	76.20	25	635.00	3	0.1181	25	0.9843
4	101.60	30	762.00	4	0.1575	30	1.1811
5	127.00	35	889.00	5	0.1969	35	1.3780
10	254.00	40	1016.00	10	0.3937	40	1.5748

10 MILLIMETERS = 1 CENTIMETER, 100 CENTIMETERS = 1 METER = 39.37 INCHES (3.3 FEET)

INCHES TO METERS

METERS TO INCHES

Inches	Meters	Inches	Meters	Meters	Inches	Meters	Inches
1	0.0254	7	0.1778	0.1	3.937	0.7	27.559
2	0.0508	8	0.2032	0.2	7.874	0.8	31.496
3	0.0762	9	0.2286	0.3	11.811	0.9	35.433
4	0.1016	10	0.2540	0.4	15.748	1.0	39.370
5	0.1270	11	0.2794	0.5	19.685	1.1	43.307
6	0.1524	12	0.3048	0.6	23.622	1.2	47.244

TO CONVERT METERS TO CENTIMETERS, MOVE DECIMAL POINT TWO PLACES TO THE RIGHT

YARDS TO METERS

METERS TO YARDS

Yards	Meters	Yards	Meters	Meters	Yards	Meters	Yards
1	0.91440	6	5.48640	1	1.09361	6	6.56168
2	1.82880	7	6.40080	2	2.18723	7	7.65529
3	2.74320	8	7.31520	3	3.28084	8	8.74891
4	3.65760	9	8.22960	4	4.37445	9	9.84252
5	4.57200	10	9.14400	5	5.46807	10	10.93614

MOVE DECIMAL POINT FOR HIGHER VALUES — e.g. 6,000 METERS = 6,561.68 YARDS

POUNDS TO KILOGRAMS

KILOGRAMS TO POUNDS

lb	kg	lb	kg	kg	lb	kg	lb
1	0.454	6	2.722	1	2.205	6	13.228
2	0.907	7	3.175	2	4.409	7	15.432
3	1.361	8	3.629	3	6.614	8	17.637
4	1.814	9	4.082	4	8.818	9	19.842
5	2.268	10	4.536	5	11.023	10	22.046

GALLONS TO LITERS

LITERS TO GALLONS

Gallons	Liters	Gallons	Liters	Liters	Gallons	Liters	Gallons
1	3.79	10	37.86	1	0.26	60	15.66
2	7.57	20	75.71	2	0.53	90	23.77
3	11.36	30	113.57	5	1.32	120	31.32
4	15.14	40	151.42	10	2.64	150	39.62
5	18.93	50	189.28	20	5.28	180	47.54

PINTS TO LITERS

LITERS TO PINTS

Pints	Liters	Pints	Liters	Liters	Pints	Liters	Pints
1	0.47	6	2.84	1	2.11	6	12.68
2	0.95	7	3.31	2	4.23	7	14.79
3	1.42	8	3.79	3	6.34	8	16.91
4	1.89	9	4.26	4	8.45	9	19.02
5	2.37	10	4.73	5	10.57	10	21.13

TEMPERATURE

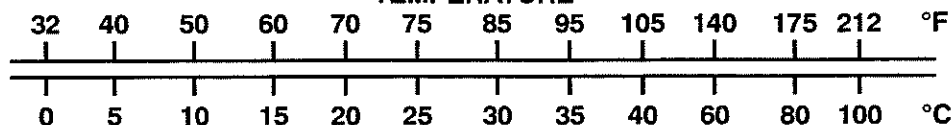

SUGGESTED SPARE PARTS

WESTERBEKE MARINE GASOLINE GENERATORS

CONTACT YOUR WESTERBEKE DEALER FOR SUGGESTIONS AND ADDITIONAL INFORMATION

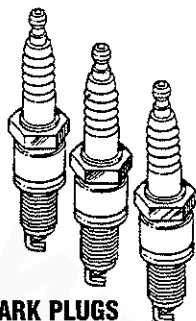

SPARK PLUGS

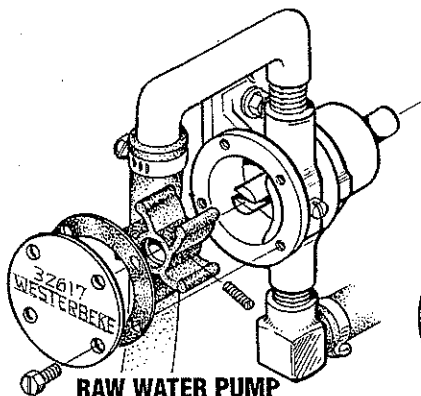

RAW WATER PUMP
IMPELLER/GASKET

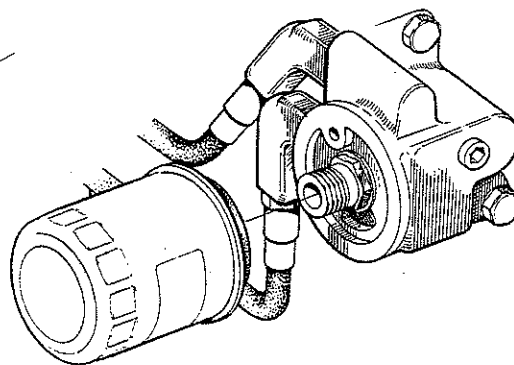

OIL FILTER

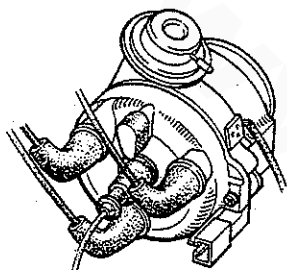

DISTRIBUTER CAP WITH WIRES

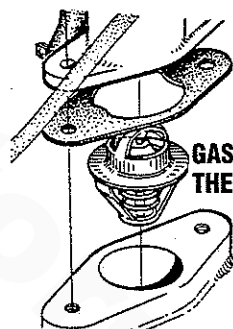

GASKET &
THERMOSTAT

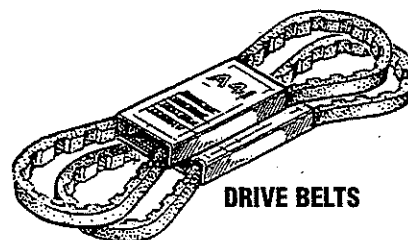

DRIVE BELTS

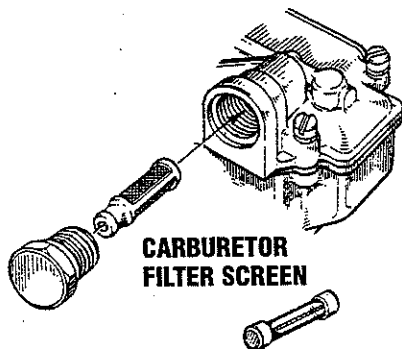

CARBURETOR
FILTER SCREEN

SPARE FUSES

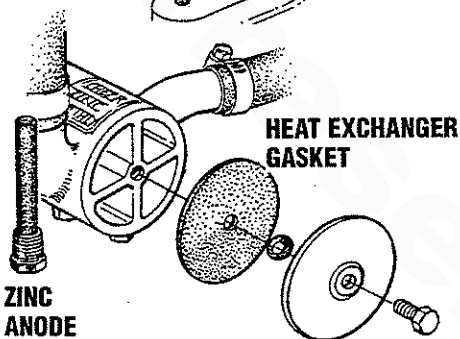

HEAT EXCHANGER
GASKET

ZINC
ANODE

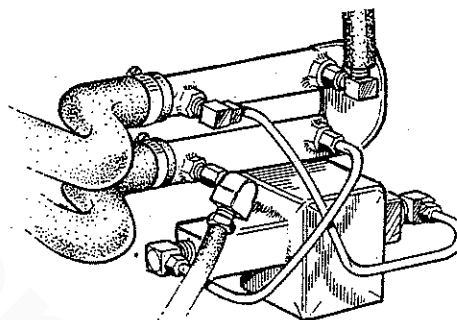

FUEL LIFT
PUMP

SPARE PARTS KIT

WESTERBEKE offers two Spare Parts Kits, each packaged in a rugged hinged toolbox.

Kit A includes the basic spares.

Kit B is for more extensive off-shore cruising.

KIT A

- Impeller Kit
- Heat Exchanger Gasket
- Oil Filter
- Drive Belt
- Zinc Anodes
- Spark Plugs

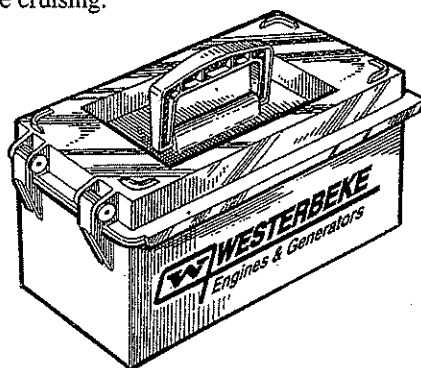

KIT B

- Impeller Kit
- Water Pump Repair Kit
- Thermostat Kit
- Zinc Anodes
- Complete Gasket Kit
- Heat Exchanger Gasket
- Oil Filter
- Drive Belt
- Spark Plugs



www.torresen.com

1012WMDW7/99

