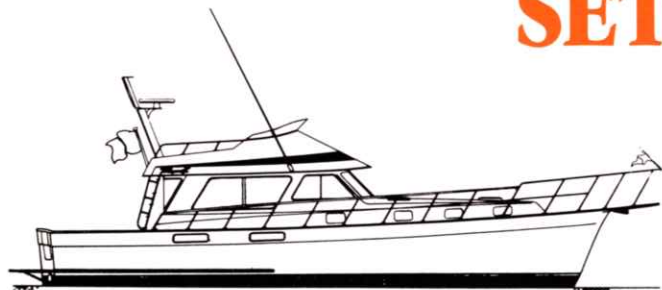

**WESTERBEKE 6 KW MARINE DIESEL GENERATOR****WESTERBEKE  
6 KW  
MARINE DIESEL  
GENERATOR  
SET**

TOLLYCRAFT 48' CONVERTIBLE

A small, reliable, smooth running Generator Set for all your shipboard needs; 120 volt electrical power at the turn of a switch for: Electric Cooking, Microwave Oven, Refrigeration, Cabin Appliances, Power Tools, and Navigation/Communication Equipment. Like all Westerbeke Generator Sets, it is fresh water cooled with an Engine mounted Heat Exchanger. The Engine and Generator are connected through special Drive Discs into a compact carefully aligned Generator Set. The complete unit is mounted on lightweight rails through soft flexible Isolator Mounts that prevent the transfer of vibration. A lightweight removable Drip Tray is fitted under the unit between the mounting rails. The Engine is fitted with a Bosch Type Pump and Self Bleeding Fuel System that eliminates hand priming and bleeding. Cast iron cylinder head and block plus swirl type combustion chamber plus tuned air intake silencer produce quiet running unmatched in the industry.

The Westerbeke 6 is lightweight, safe, dependable, durable, and economical to operate. Designed to operate at a quiet 1800 RPM, the Westerbeke 6 offers 3 cylinder, 4 cycle smoothness to provide complete electric conveniences usually found only on larger boats.

*For power or sailboat . . . a new series of compact diesel generator sets from Westerbeke.*

**The all-new Westerbeke compact brushless BC series diesel generator . . . quietest yet.**

- **SMOOTH 3 CYLINDER 4 CYCLE PERFORMANCE**
- **ENCLOSED FRESH WATER COOLING**
- **AUTOMATIC SAFETY SHUT-DOWNS**
- **SIMPLE ENGINE AND GENERATOR CONTROLS FOR RELIABILITY**

**STANDARD EQUIPMENT**

- 12 Volt 10 Amp Battery Charging
- Coolant Recovery Tank
- Operators Manual
- Vibration Isolators
- Control Panel
- Water Injected Exhaust Elbow
- Drip Tray
- Belt Guard
- Air Intake Silencer
- 12 Volt Start Motor
- High Water Temp. Low Oil Pressure
- High Exh. Temp. Auto Shutdown
- 45° Water Injected Exhaust Elbow
- Oil Drain Hose
- Safety Stop Switch

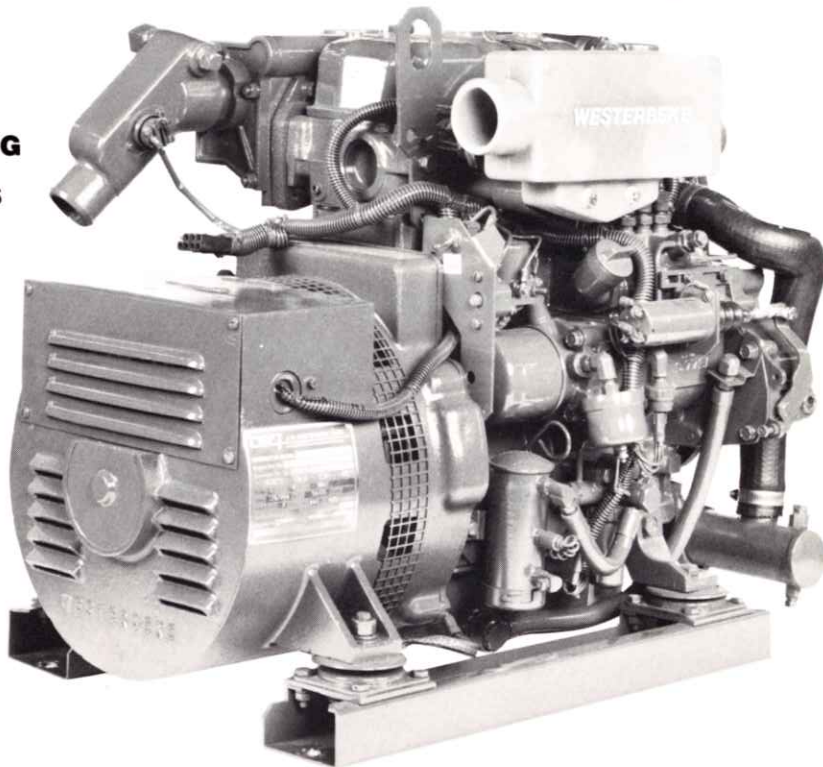

**GENERATORS: 3, 4.4, 6, 8, 11, 12.5, 15, 20, 25, 32, 45 kw's**

*Fresh Water Cooled Diesel and Gasoline Generators from Westerbeke.*



# WESTERBEKE 6 KW MARINE DIESEL GENERATOR

**WESTERBEKE 6 KW**

**DESIGN:** Brushless, four pole revolving field, self regulating, pre-lubricated single bearing design.

**VOLTAGE REGULATION:** Standard  $\pm 5\%$  no load to full load.

**FREQUENCY REGULATION:** 3 Hertz (5%) no load to full load. (Generator is capable of operation at either 50 or 60 Hertz by simple adjustments.)

**INSULATION:** Class "F" as defined by NEMA MG1-1.65.

**TEMPERATURE RISE:** Within NEMA MG1-22.40 definition when operating at full load.

**COOLING:** Cast centrifugal blower, direct connected.

**ELECTROMAGNETIC INTERFERENCE LEVEL:** Exceeds requirements for most marine radio-telephone equipment and standard AM televisions.

ELECTRICAL CHARACTERISTICS						RATINGS		DERATINGS		ENGINE	
Model	Volts	Amps	Hertz	Phase	Wire	Power Factor	KW			RPM	Start
6-614*	120/240	50/25	60	1	4	1.0	6	3.5% each 1000 feet above sea level.		1800	Remote
4.5-514	220	20.4	50	1	4	1.0	4.5	1% for each 10° Fahrenheit above 85° Fahrenheit ambient. 10% for continuous duty.		1500	Remote

\*Reconnectable to 120 Volts @ twice the amperage.

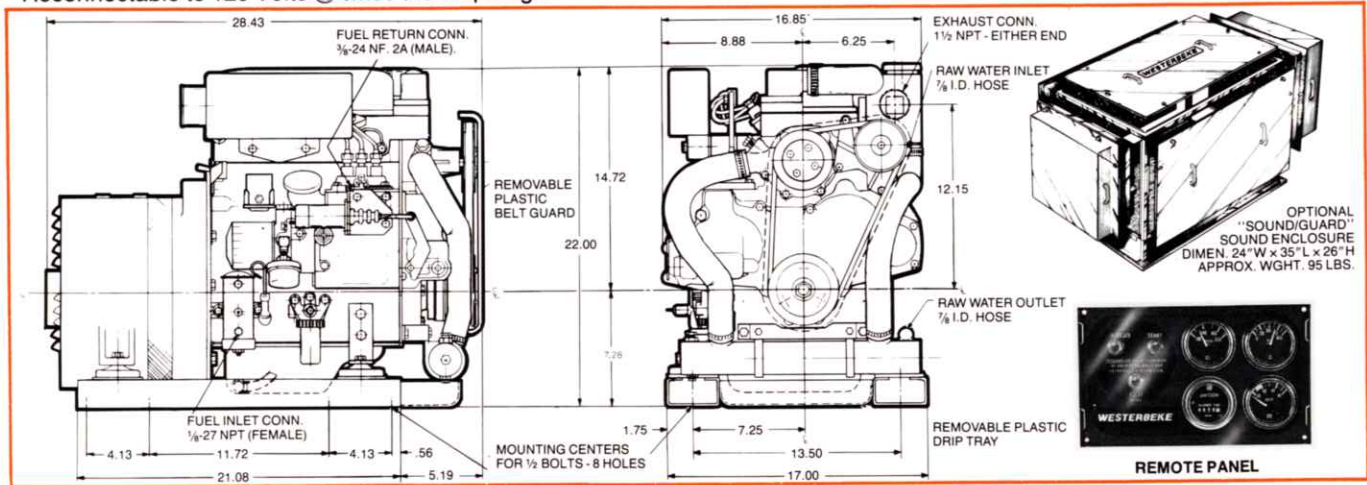

## ENGINE

Engine Type . . . 3 cylinder, 4 cycle, water cooled, naturally aspirated, vertical overhead valve, diesel engine  
 Bore & Stroke . . . . . 2.56" x 3.07"  
 Displacement . . . . . 47.4 CID  
 Compression Ratio . . . . . 23 to 1  
 Cooling water capacity . . . . . 5 Qts.  
 Fuel Injection Pump . . . . . Bosch type with Individual plunger for each cylinder  
 Injectors . . . . . Pintle type  
 Combustion Chamber . . . . . Swirl type for easy starting and quiet operation  
 Total weight . . . . . 440 lbs  
 Governor . . . . . Mechanical centrifugal type  
 Fuel filter . . . . . Paper element type  
 Lub. oil filter . . . . . Full flow, spin on, paper element type  
 Lub. oil capacity with filter . . . . . 3.3 Qts.  
 Starting motor . . . . . Geared electric motor, 12 Volt  
 Starting aid . . . . . 12 Volt sheathed type glow plug  
 Fuel pump . . . . . Electric plunger type  
 Rated RPM . . . . . 1800  
 Max. HP at rated RPM . . . . . 12 HP  
 Full load fuel consumption . . . . . approx. 0.7 G.P.H.  
 Exhaust hose . . . . . 1 7/8" I.D.  
 Sea water hose . . . . . 7/8" I.D.

## STANDARD EQUIPMENT

12 volt 10 amp Charging • Coolant recovery tank  
 Fresh Water Cooling System • 15 ft Panel Harness  
 Air Intake Silencer • 12 Volt Starting Motor  
 Vibration Isolators • Remote Panel  
 Water Injected Exhaust Elbow  
 Drip Tray • Belt Guards

## OPTIONAL EQUIPMENT

Hydro-Hush Silencer • "Sound/Guard" • Remote Start-Stop Panel • Ship to Shore Transfer Switch.

Call your Westerbeke representative

or contact the . . .