

NORDFARER YAWL
by
John G. Alden, Inc.

WESTERBEKE 50 DIESEL ENGINE

FEATURES:

Smooth and Quiet

Demonstrably smoother and quieter than other 4 cylinder engines of equivalent horsepower.

Rugged and Dependable

5 main bearing crankshaft, fresh water cooling, lube oil cooler.

Economical

modern combustion chamber provides maximum power with minimum noise.

Compact and Powerful

41 h.p. at 3200 R.P.M.
110 cubic inches
585 lbs. with 2:1 Short Profile Sailing Gear.

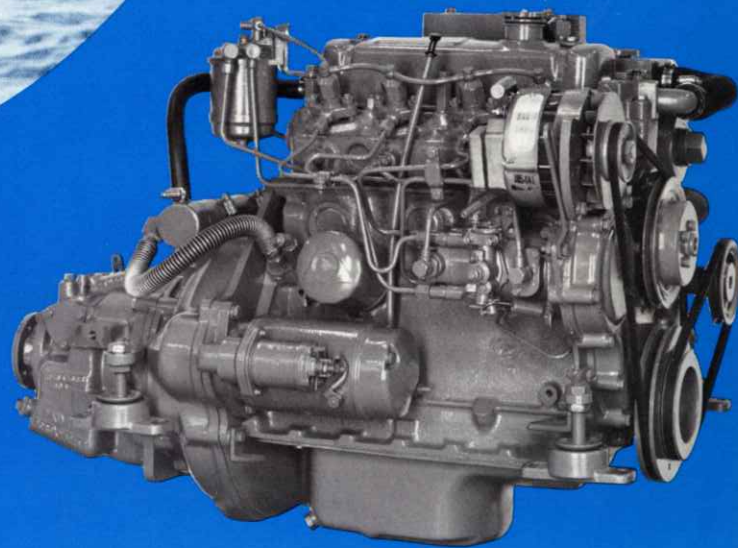

WESTERBEKE 50 with 2:1 Short Profile Sailing Gear

WESTERBEKE 50 with Direct Drive Warner Hydraulic Gear

WESTERBEKE 50

The Westerbeke 50 is rated 41 horsepower at 3200 RPM. Five main bearing ruggedness sets the engine apart from competition and makes it ideally suited for yacht club launch and other commercial applications. The modern design combustion chambers give a most efficient and quiet burn, providing the engine with a maximum of power per pound with a minimum of noise. During testing the Westerbeke 50 proved to be demonstrably smoother and quieter than other engines of similar horsepower. These characteristics, plus its thoughtfully rugged design and compact size, make it just about perfect as auxiliary power for sailboats and smaller displacement cruisers.

The engine is available with manual or hydraulic transmissions in various gear ratios including

vee-drives and the new 2:1 short profile sailing transmission. With this transmission the Westerbeke 50 is one of the smallest and lightest engines available in its horsepower class.

An unusually long list of standard equipment comes with this new engine including fresh water cooling, lube oil cooler, factory prewiring, large alternator, and adjustable flexible mounts.

The exhaust opening is available either front or rear opening, a particular advantage in V-drive installations. Some of the options available for the Westerbeke 50 include water injected exhaust elbow, for use with our Hydro-Hush waterlift muffler, prewired all electric plug-in instrument panel with 10' of cable; high water temperature, low oil pressure alarm system, and remote lubrication oil filter.

SPECIFICATIONS

Type: Four cylinder four cycle overhead valve vertical in-line diesel.

Displacement: 110 cu. in. Bore 3 5/32", Stroke 3 1/2".

Power: 41 HP at 3200 RPM (see power curve.)

Compression Ratio: 21.47:1

Weight: 560 lbs. basic engine. Add gear weights opposite page for IOR weight.

Fuel Injection Equipment: CAV distributor type injection pump and CAV Pintaux nozzels working in conjunction with Ricardo Comet V combustion chambers.

Cylinder Block and Head: Special cast iron mono blocks.

Crankshaft: Forged steel, counter balanced.

Camshaft: Forged steel.

Connection Rods: I section alloy steel stampings.

Pistons: Aluminum alloy with solid skirt.

Main bearings: Five, tri metal, heavy duty.

Lubrication: Wet sump. Eccentric rotor pressure pump, camshaft-driven.

Exhaust Manifold: Fresh water cooled. Front or rear opening.

Cooling System: Closed circuit system, including lube oil cooler with heat exchanger mounted.

Angle of Installation: 15° maximum.

Electrical System: 12-volt negative grounded system with 55 amp alternator.

Transmission: See individual gears opposite for specifications and propeller rotation.

Mounting: Flexible rubber mounts on 18" centers standard.

STANDARD EQUIPMENT

Fresh water cooling system including lube oil cooler, with heat exchanger; surge tank and pumps mounted on engine; flexible engine mounts; propeller shaft coupling; clutch lever with lower extension for remote control where applicable; mounting brackets for control cables; spin-on full flow lube oil filter, sump pump and hose; engine-mounted secondary fuel

oil filter, fuel lift pump with hand primer, flexible hoses for fuel inlet and return; cold weather starting aid; 12 volt, 55 amp alternator with transistor regulator; plug-in engine pre-wiring including pre-wired start panel with 10' cable; threaded 1 1/2" IPS exhaust flange; fully illustrated instruction manual and parts list.

OPTIONAL EQUIPMENT

High efficiency primary fuel filter; remote lubrication oil filter; front opening exhaust manifold; water injected exhaust elbow; Hydro-Hush stainless steel waterlift muffler; flexible stainless steel exhaust section; sea water strainer; remote fresh water expansion tank; hot water heater connection kit; pre-wired all-electric instrument panel with 10' cable, extra 10' cable for instrument panel or start panel; high water temperature, low oil pressure alarm system; flexible shaft coupling; spare parts kits.

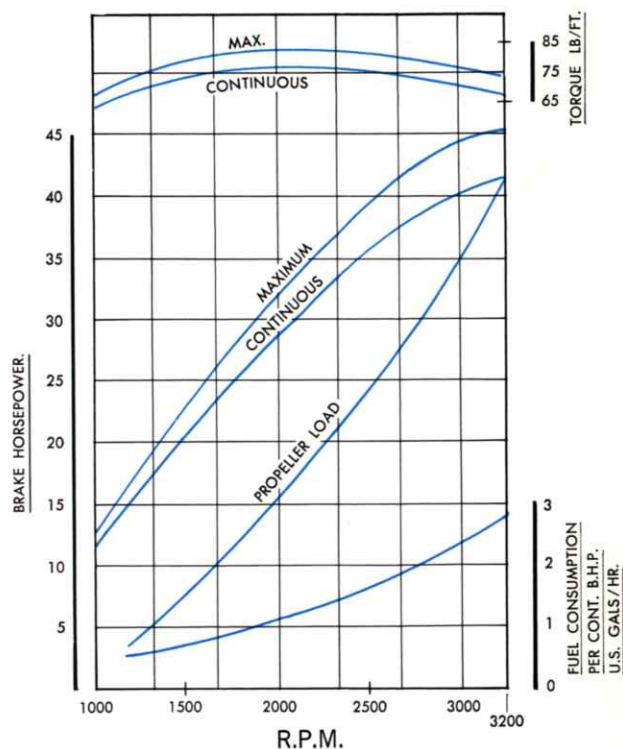

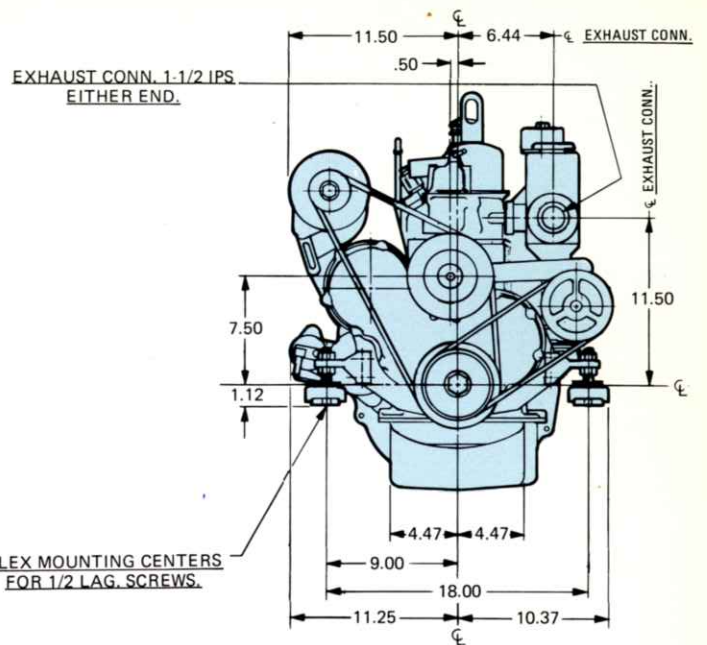
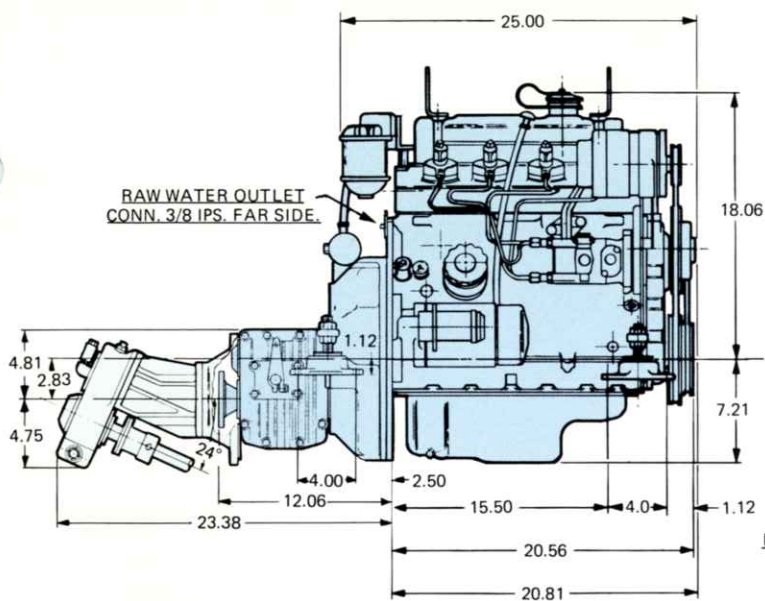

WESTERBEKE Short Profile Sailing Gear. The most compact 2:1 reduction package ever! Features positive neutral for free-wheeling, silent-running shaved case-hardened helical gears, heavy-duty tapered roller bearings, and instant acting fingertip control. (Use Morse 33C cable or equal.) Weight 25 lbs. Turns right hand propeller. Drawing above shows Walter vee-drive close coupled to the sailing gear. Reduction, 2:1. Weight 70 lbs. Turns right hand propeller.

RATIO	DIM. A	DIM. B	OFFSET
1.50:1	21.16	4.50	.85
2.04:1	21.16	4.50	1.30
2.52:1	21.47	5.25	1.90
3.00:1	21.47	5.25	2.10

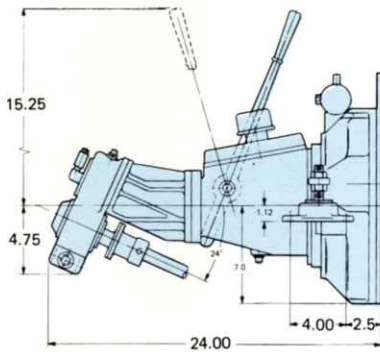

PARAGON SAOV. Use our front end exhaust outlet with this manual vee-drive. Available in ratios of 1.29:1, 1.67:1 and 2:1. Weight 90 lb. Turns left hand propeller.

PARAGON P20 Hydraulic Gear. Available with direct drive and in 1½, 2, 2½ and 3 to 1 ratios. The small offset (see table) can be turned down or up to suit the installation. Weight, direct drive 100 pounds, reduction gear 150 pounds. Turns left hand propeller.

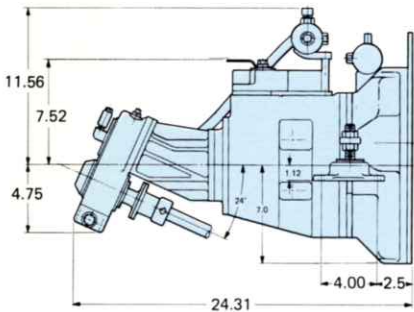
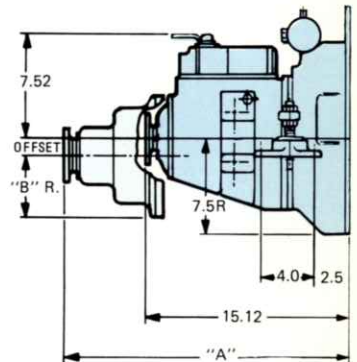

PARAGON Hydraulic Vee-Drive. A Paragon P20 hydraulic gear close-coupled to a Walter vee-drive. Ratios of 1.29:1, 1.67:1, and 2:1. Weight 132 lb. Turns left hand propeller.

SAO Paragon direct manual gear. Weight 58 lb. Turns left hand propeller. Also shown, reduction gear with 1½:1 and 2:1 ratios. Weight 82 lb. Turns left hand propeller.

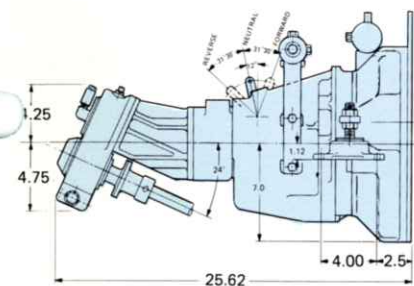
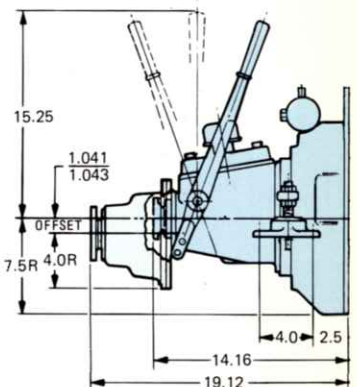

WARNER Hydraulic Vee-Drive. A Warner gear coupled to a Walter vee-drive. Ratios of 1.29:1, 1:67:1, and 2:1. Weight 135 lbs. Turns left hand propeller.

WARNER Hydraulic Gear. In-line construction with no offset. Available with direct drive and 1½, 2, 2½ and 3 to 1 ratios for left hand propellers, and 1.9:1 for right hand propellers. Weight, direct drive 96 pounds, reduction gear 147 pounds.

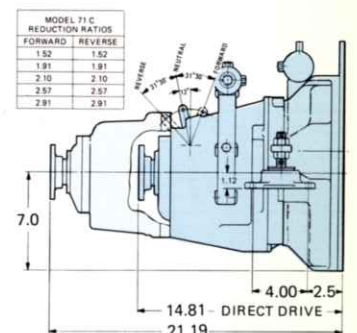

MODEL 71 C REDUCTION RATIOS	
FORWARD	REVERSE
1.52	1.52
1.91	1.91
2.10	2.10
2.57	2.57
2.91	2.91

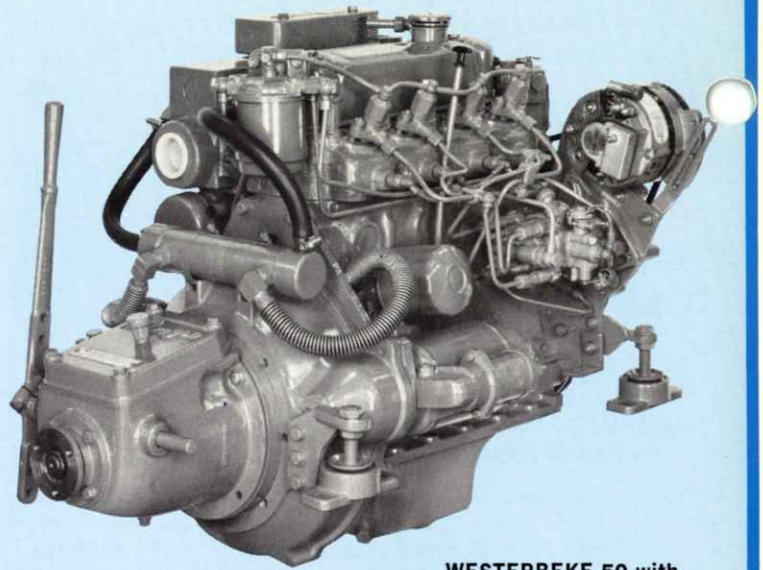
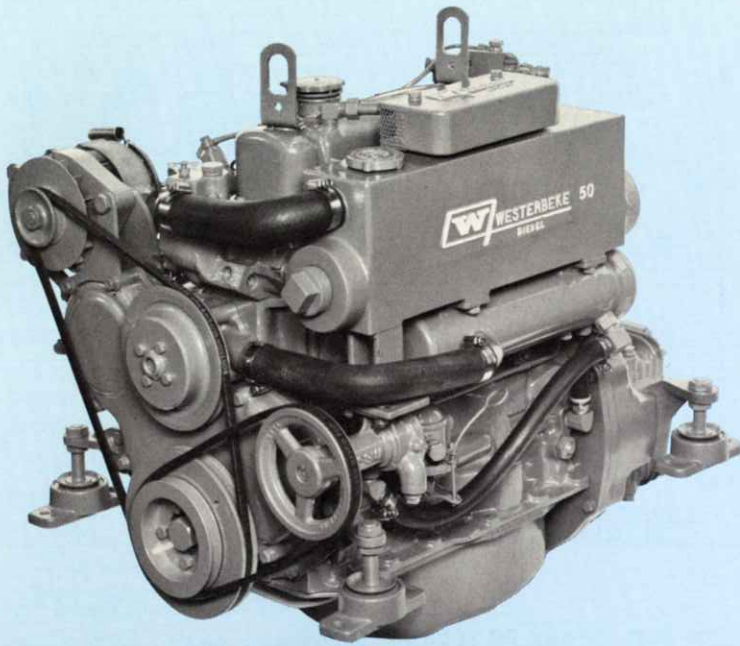

**WESTERBEKE 50 with
Direct Drive Paragon Manual Gear**

The accessories shown below may be ordered with your engine or purchased separately through Westerbeke Dealers and Distributors:



All Electric Panel — plugs into engine prewiring.



Hydro Hush Muffler used in conjunction with water injected elbow for quieter exhaust systems.



Flexible Shaft Coupling — for smoother performance.



Westerbeke Fuel Water Separator has optional visual/audible alarm when water reaches high point in sediment bowl.



Water Injected Exhaust Elbow, for use with water lift muffler systems.



Alarm System — Engines may be prewired to accept Westerbeke sonic beeper or Aqua Alarm bell.

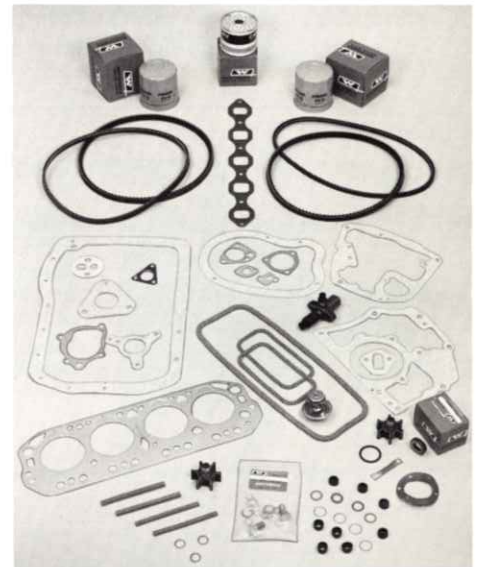

Spare Parts — A & B Kits are available for on board replacements or emergency repairs.



J. H. WESTERBEKE CORP.

AVON INDUSTRIAL PARK, AVON, MASS. 02322 • (617) 588-7700
CABLE: WESTCORP, AVON • TELEX: 92-4444